

**(12) PATENT**  
**(19) AUSTRALIAN PATENT OFFICE**

**(11) Application No. AU 199889339 B2**  
**(10) Patent No. 759695**

(54) Title  
Method of minimizing power consumption within an electronic price label

(51)<sup>6</sup> International Patent Classification(s)  
H02H 003/027 G09F 003/02

(21) Application No: 199889339 (22) Application Date: 1998.10.15

(30) Priority Data

(31) Number (32) Date (33) Country  
08/969912 1997.11.13 US

(43) Publication Date : 1999.06.03  
(43) Publication Journal Date : 1999.06.03  
(44) Accepted Journal Date : 2003.04.17

(71) Applicant(s)  
NCR International, Inc

(72) Inventor(s)  
John Coker Goodwin III

(74) Agent/Attorney  
BALDWIN SHELSTON WATERS,Level 21,60 Margaret Street,SYDNEY NSW 2000

(56) Related Art  
US 5539393  
US 5544041  
US 5797132

METHOD OF MINIMIZING POWER CONSUMPTION  
WITHIN AN ELECTRONIC PRICE LABEL

Abstract

A method of minimizing power consumption within an electronic price label (EPL) (18) which conserves life of its battery (40). A time period for removing power from a transceiver (44) within the EPL is determined by a computer (12) from price change frequency data. A message to control circuitry within the EPL is sent by the computer as soon as possible following a change in price displayed by the EPL. The message includes a command to remove power from the transceiver and the power down time period. Power is removed from the transceiver by the control circuitry. The control circuitry counts until the power down time period is exhausted. Power is applied to the transceiver by the control circuitry when the power down time period is exhausted. Finally, a first time within the control circuitry is synchronized by the control circuitry to a second time indicated by the computer after the power down timer period is exhausted and before any additional message is sent to the EPL.

Fig.3



**AUSTRALIA**

**PATENTS ACT 1990**

**COMPLETE SPECIFICATION**

FOR A STANDARD PATENT

**ORIGINAL**

---

Name of Applicant/s: NCR International, Inc

Actual Inventor/s: John Coker Goodwin III

Address for Service: BALDWIN SHELSTON WATERS  
60 MARGARET STREET  
SYDNEY NSW 2000

Invention Title: "METHOD OF MINIMIZING POWER CONSUMPTION WITHIN AN  
ELECTRONIC PRICE LABEL"

The following statement is a full description of this invention, including the best method of performing it known to me/us:-

File: 21360.00

**METHOD OF MINIMIZING POWER CONSUMPTION**

**WITHIN AN ELECTRIC PRICE LABEL**

The present invention relates to electronic price label (EPL) systems, and more specifically to a method of minimizing power consumption within an EPL.

5 Any discussion of the prior art throughout the specification should in no way be considered as an admission that such prior art is widely known or forms part of common general knowledge in the field.

EPL systems typically include a plurality of EPLs for each merchandise item in a store. EPLs include displays which display the price of corresponding merchandise items on  
10 store shelves and are typically attached to a rail along the leading edge of the shelves. EPL systems typically obtain their prices from the POS server's PLU file. A store may contain thousands of EPLs to display the prices of the merchandise items. The EPLs are coupled to a central server from where information about the EPLs is typically maintained in an EPL data file. The EPL data file contains EPL identification information, and EPL merchandise item  
15 information.

EPLs are typically powered by batteries. The current expected life of an EPL battery is about 5-7 years. Receiving circuitry draws most of the power, even though operation of the receiving circuitry is only required during transmission of messages from the central server.

20 Various methods of saving EPL battery life are disclosed in International Patent Application Nos. WO 9411834 and WO 9411833. A monitoring module automatically senses a power drop from the main source of power (a solar panel) to initiate a power saving mode of operation. After an operating time  $t$ , the monitoring module removes power from high power components for a time  $n*t$ .



However, inclusion of a separate monitoring module adds cost to an EPL. The cost is significant to an installation involving thousands of EPLs. Also, requiring that all EPLs sleep after an interval  $t$  for a period  $n*t$  is inconsistent with the system utilisation.

It is an object of the present invention to overcome or ameliorate at least one of the  
5 disadvantages of the prior art, or to provide a useful alternative.

It would be advantageous for an EPL system to be able to track and anticipate when communications (e.g., price changes) need to occur. The system's ability to anticipate would allow it to improve throughput because the EPLs would be ready when needed.

Additionally, if anticipation were done correctly, EPLs could be made to sleep longer, thus  
10 prolonging their battery lives. For example, if a retailer were only to make price changes at night between midnight and six o'clock a.m., then the EPLs could actually sleep for eighteen hours per day.

According to one aspect of the invention there is provided a method of minimising power consumption by an Electronic Price Label (EPL) comprising:

15 determining a time period for removing power from predetermined components within an EPL from price change frequency data;

20 sending a message to control circuitry within the EPL, which includes a command to remove power from the predetermined components within the EPL and a power down time period, by a remote computer;

20 removing power from the predetermined components by the control circuitry in response to the sent message;

measuring time until the power down time period is exhausted; and

reapplying power to the predetermined components when the power down time period

is exhausted.

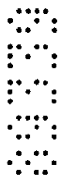

According to a further aspect of the invention there is provided a low power electronic price label system comprising:

a plurality of electronic price labels (EPLs);

a remote computer for selectively sending mode control messages to control circuitry  
5 within the EPLs, said mode control messages including a command to remove power from predetermined components within the EPLs and a power down time period;

the control circuitry within each of the EPLs being operable to remove power from the predetermined components upon receipt of a mode control message, to determine that the power down period has passed, and to reapply power to the predetermined components after  
10 the power down period has passed;

wherein the remote computer determines the power down time period based upon an analysis of price change frequency data for the EPLs.

Unless the context clearly requires otherwise, throughout the description and the claims, the words 'comprise', 'comprising', and the like are to be construed in an inclusive  
15 sense as opposed to an exclusive or exhaustive sense; that is to say, in the sense of "including, but not limited to".

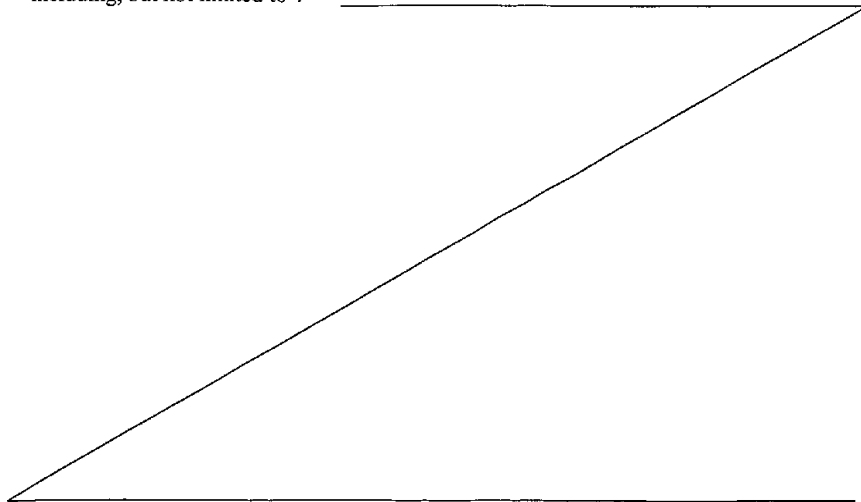

The invention will now be described by way of example with reference to the accompanying drawings, in which:

- 5 Fig. 1 is a block diagram of an EPL system;  
Fig. 2 is a block diagram of an EPL; and  
Fig. 3 is a flow diagram illustrating the power saving method of the present invention.

Referring now to Fig. 1, EPL system 10 includes computer 12, storage medium 14, communication base station (CBS) 16, and electronic price labels (EPLs) 18.

10 Computer 12 executes EPL control software 20 and mode control software 22. EPL control software 20 records, schedules, and transmits all messages to EPLs 18 through CBS 16, and receives and analyzes messages from EPLs 18 through  
15 CBS 16.

EPL control software 20 maintains and uses EPL data file 28. EPL data file 28 contains item information, EPL identification information, and status information for each of EPLs 18.

20 EPL control software 20 primarily includes data scheduler 34 and CBS manager 36. Data scheduler 34 schedules EPL price change messages to be sent to EPLs 18 through CBS 16. Data scheduler 34 schedules polling and EPL computer acknowledgment messages to be sent to device 24  
25 through CBS 16.

CBS manager 36 controls transmission of price change messages and polling messages to EPLs 18. CBS manager 36 controls reception of status and acknowledgment messages from EPLs 18.

30 Mode control software 22 causes EPL control software 20 to schedule and transmit a mode control message

to one or more of EPLs 18. The mode control message causes an EPL to remove power from predetermined components for a predetermined time period. Mode control messages are preferably scheduled and sent in batches.

5 Storage medium 14 is preferably a fixed disk drive. Storage medium 14 stores EPL data file 28.

CBS 16 preferably includes one transmit antenna 37 and up to four receive antennas 38 for transmitting and receiving messages between CBS 16 and EPLs 18. CBS 16  
10 includes CBS circuitry 39 which controls operation of CBS 16. EPL system 10 preferably includes a plurality of CBSs 16 connected together in series.

Turning now to Fig. 2, EPLs 18 each include battery 40, transmit and receive antenna 42, display 46,  
15 memory 47, and EPL circuitry 48.

Battery 40 provides power to EPLs 18.

Transmit and receive antenna 42 receives price change and status messages from CBS 16. Transmit and receive antenna 42 transmits responses in the form of  
20 acknowledgments to price change and status messages to CBS 16.

Display 46 displays price and possibly additional information. Display 46 is preferably a liquid crystal display (LCD).

25 Memory 47 stores price verifier information, EPL type information, and may additionally store promotional information. Memory 47 also stores the power removal time.

EPL circuitry 48 controls the internal operation of EPLs 18. EPL circuitry 48 receives messages from EPL  
30 computer 12 and transmits response messages to EPL computer 12. EPL circuitry 48 controls display of price and other information, including blinking.



Under the method of the present invention, EPL circuitry 48 also implements a power saving mode in response to a mode control message from EPL computer 12 by removing power for a predetermined time from components that consume  
5 more power than other components. Preferably, transceiver 44 is the main component. Removing power from its amplifier, RF filters, transistors, and resistors provides enough power savings to extend battery life to seven to ten years.

10 Historical price change frequency data and currently scheduled price change frequency data are used to determine the amount of sleep time. Retailers and installers may also recommend a default time period. Although, each EPL may be assigned its own individual time  
15 period.

For example, EPL circuitry 48 includes transceiver 44. EPL circuitry 48 removes power from transceiver 44.

EPL circuitry 48 may optionally include an alternate communications channel which may be employed to  
20 communicate with an EPL 18. Functions that may be implemented using this channel may include blinking displayed information and activating an alternative display mode.

Turning now to Fig. 3, the operation of system 10  
25 in accordance with the method of the present invention is illustrated in more detail, beginning with START 60.

In step 62, mode control software 22 schedules a mode control message addressed to EPL 18, preferably as soon as possible following a verified price change.

30 In step 64, EPL software 20 transmits the mode control message. The message may include an EPL identification number if it is addressed to an individual



EPL or a global address if it is addressed to all EPLs. The message additionally includes a power down time period. EPL circuitry 48 applies power after the power down time period has expired. For example, the message may instruct the EPL  
5 start counting at power down and reapply power when it reaches a predetermined count. The count may be equal to a number of seconds or a predetermined number of some time measure that is a function of seconds.

In step 66, EPL 18 receives the mode control  
10 message.

In step 68, EPL circuitry 48 removes power from predetermined components for a predetermined time period in accordance with the message instructions.

In step 70, EPL circuitry 48 applies power to the  
15 predetermined components after the predetermined time period.

In step 72, EPL circuitry 48 synchronizes its clock with that of EPL computer 12. This step is preferably performed as soon as possible following application of  
20 power, and preferably before additional messages are sent to EPL 18.

Operation ends in step 74 to resume operation with all components powered.



THE CLAIMS DEFINING THE INVENTION ARE AS FOLLOWS:

1. A method of minimising power consumption by an Electronic Price Label (EPL) comprising:

determining a time period for removing power from predetermined components

5 within an EPL from price change frequency data;

sending a message to control circuitry within the EPL, which includes a command to remove power from the predetermined components within the EPL and a power down time period, by a remote computer;

removing power from the predetermined components by the control circuitry in

10 response to the sent message;

measuring time until the power down time period is exhausted; and

reapplying power to the predetermined components when the power down time period is exhausted.

2. The method as recited in claim 1, further comprising the step of:

15 synchronising a first time within the control circuitry to a second time indicated by the computer by the control circuitry after the power down time period is exhausted and before any additional message is sent to the EPL.

3. The method as recited in claim 1 or 2, wherein the predetermined components include a transceiver within the EPL.

20 4. The method as recited in any one of the preceding claims, wherein the step of sending comprises the step of:

scheduling the message as soon as possible following a change in price displayed by the EPL.

5. The method of any one of the preceding claims further comprising the steps of:



scheduling a price change message for the EPL using a data scheduler which synchronizes the price change message to a period when power is being applied to the predetermined components of the EPL.

6. The method of any one of the preceding claims wherein said method is applied to a plurality of EPLs in a store EPL system further comprising the steps of:

scheduling mode control messages which include a command to remove power from predetermined components within the plurality of EPLs in batches; and sending said mode control messages in batches.

7. The method of claim 6 wherein said mode control messages include an EPL identification if addressed to individual EPLs or a global address if addressed to all EPLs.

8. The method of any one of the preceding claims further comprising the step of: storing the power down time period in a memory in the EPL.

9. A low power electronic price label system comprising:

15 a plurality of electronic price labels (EPLs);

a remote computer for selectively sending mode control messages to control circuitry within the EPLs, said mode control messages including a command to remove power from predetermined components within the EPLs and a power down time period;

20 the control circuitry within each of the EPLs being operable to remove power from the predetermined components upon receipt of a mode control message, to determine that the power down period has passed, and to reapply power to the predetermined components after the power down period has passed;

wherein the remote computer determines the power down time period based upon an analysis of price change frequency data for the EPLs.



10. The system of claim 9 wherein said remote computer further comprises a data scheduler for scheduling EPL price change messages during periods when the predetermined components are being supplied with power.

11. A method of minimising power consumption in an electronic price label system  
5 substantially as herein described with reference to any one of the embodiments of the invention illustrated in the accompanying drawings.

12. A low power electronic price label system substantially as herein described with reference any one of the embodiments of the invention illustrated in the accompanying drawings.

10

DATED this 14th day of February, 2003  
BALDWIN SHELSTON WATERS  
Attorneys for: NCR INTERNATIONAL, INC.

15



FIG. 1

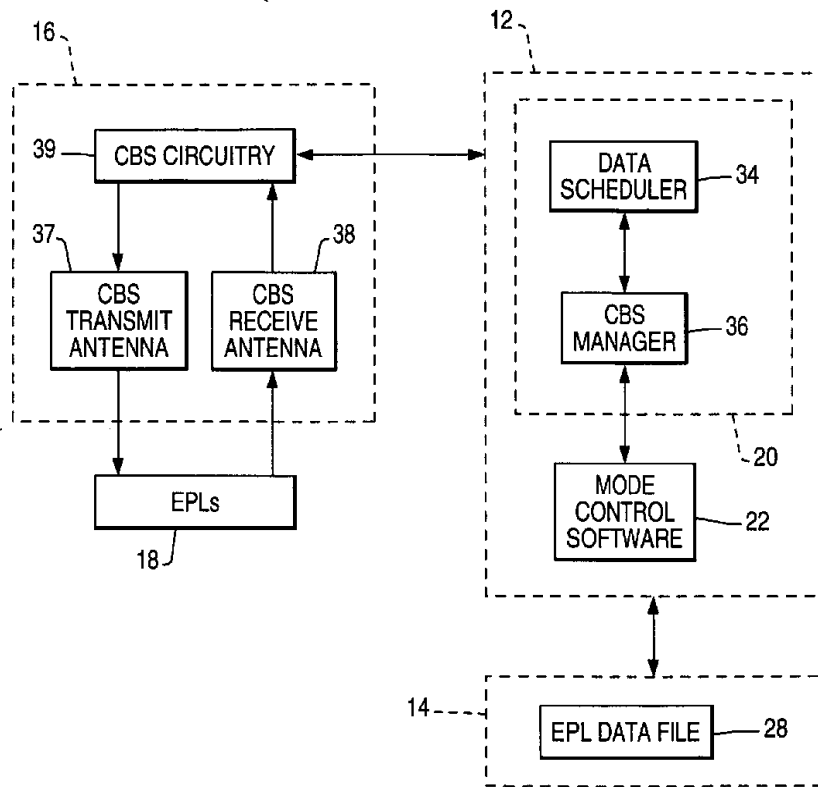

FIG. 2

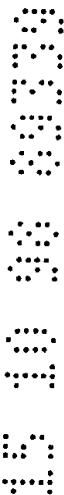
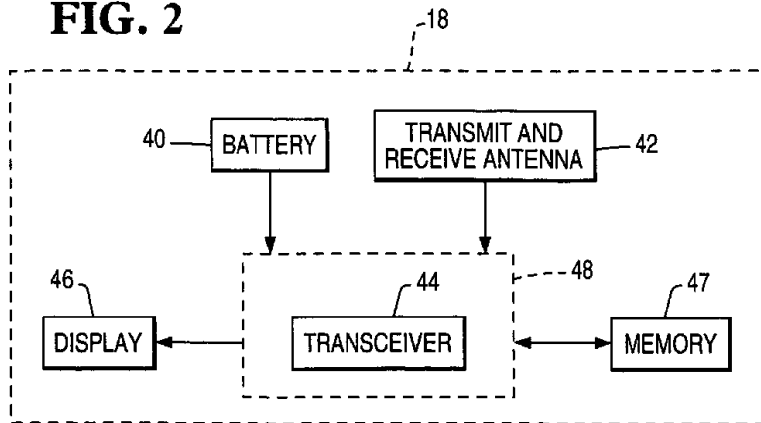

FIG. 3

