



US 20140183431A1

(19) **United States**

(12) **Patent Application Publication**
Robinson

(10) **Pub. No.: US 2014/0183431 A1**

(43) **Pub. Date: Jul. 3, 2014**

(54) **PROTECTIVE PADDING**

(71) Applicant: **Troy Robinson**, Villa Park, CA (US)

(72) Inventor: **Troy Robinson**, Villa Park, CA (US)

(21) Appl. No.: **13/729,573**

(22) Filed: **Dec. 28, 2012**

Publication Classification

(51) **Int. Cl.**
E04H 17/16 (2006.01)

(52) **U.S. Cl.**

CPC **E04H 17/16** (2013.01)

USPC **256/24**

(57) **ABSTRACT**

A protective padding assembly for covering a section of chain link fence of the character found in sports venues, such as baseball fields, soccer fields, football fields and the like, wherein the section of chain link fence includes a hingeably connected swinging gate. The protective padding assembly uniquely includes a fence covering section, a gate covering section and an intermediate, wedge shaped portion for covering the gate hinges in a manner that will not interfere with opening and closing the gate.

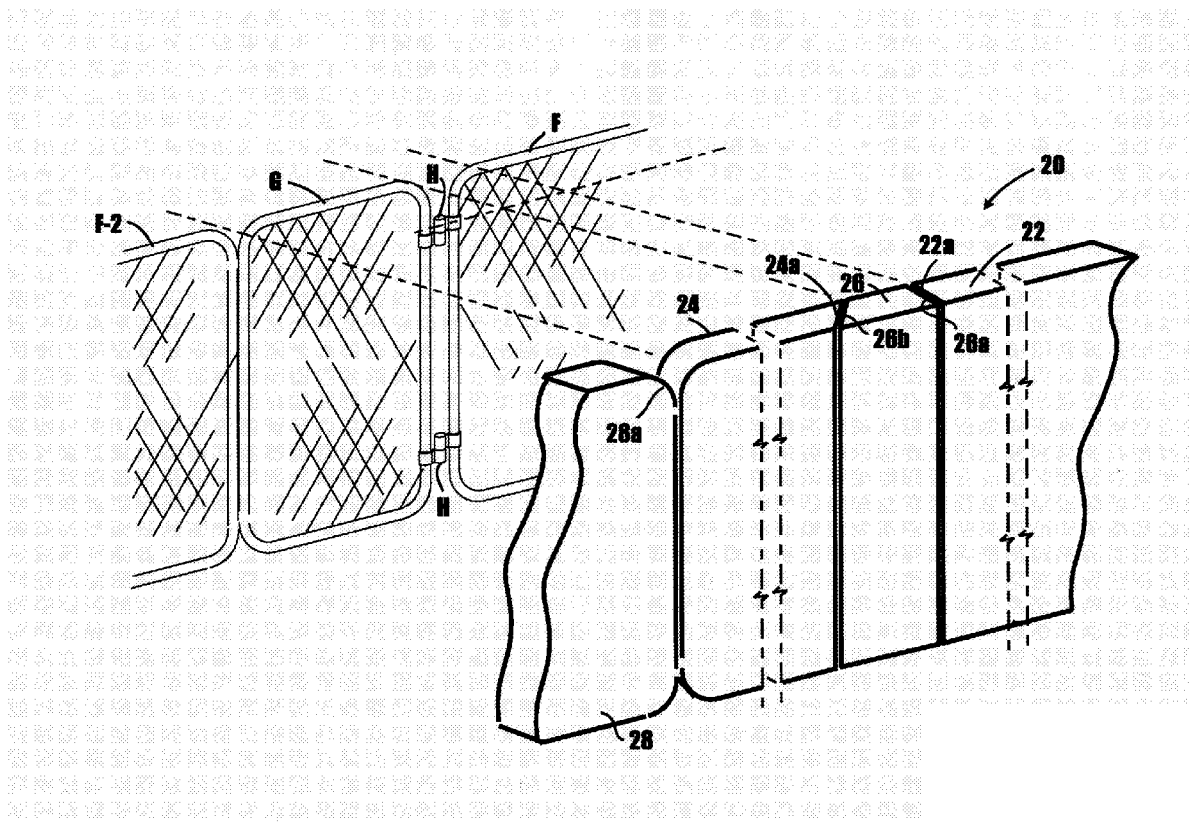

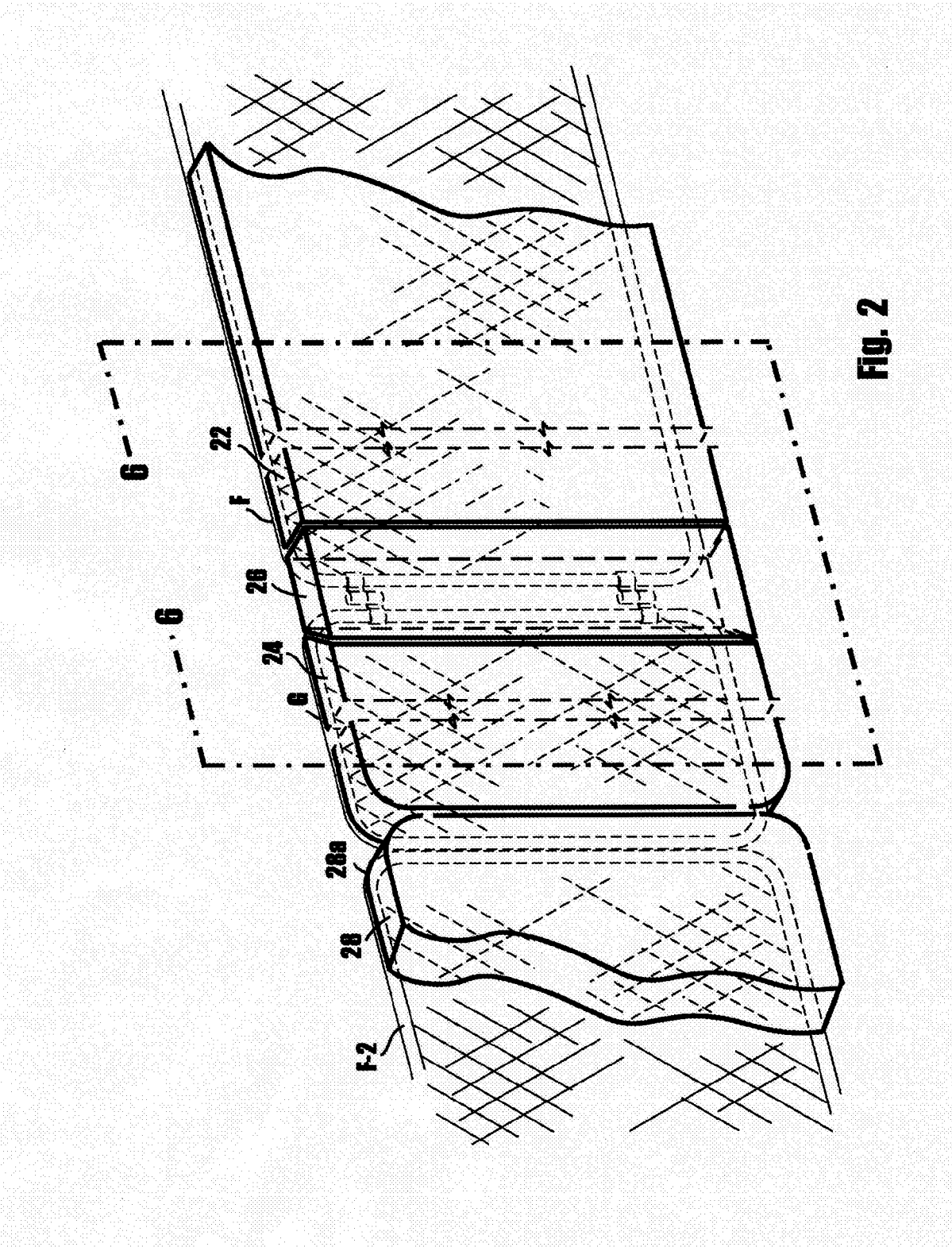
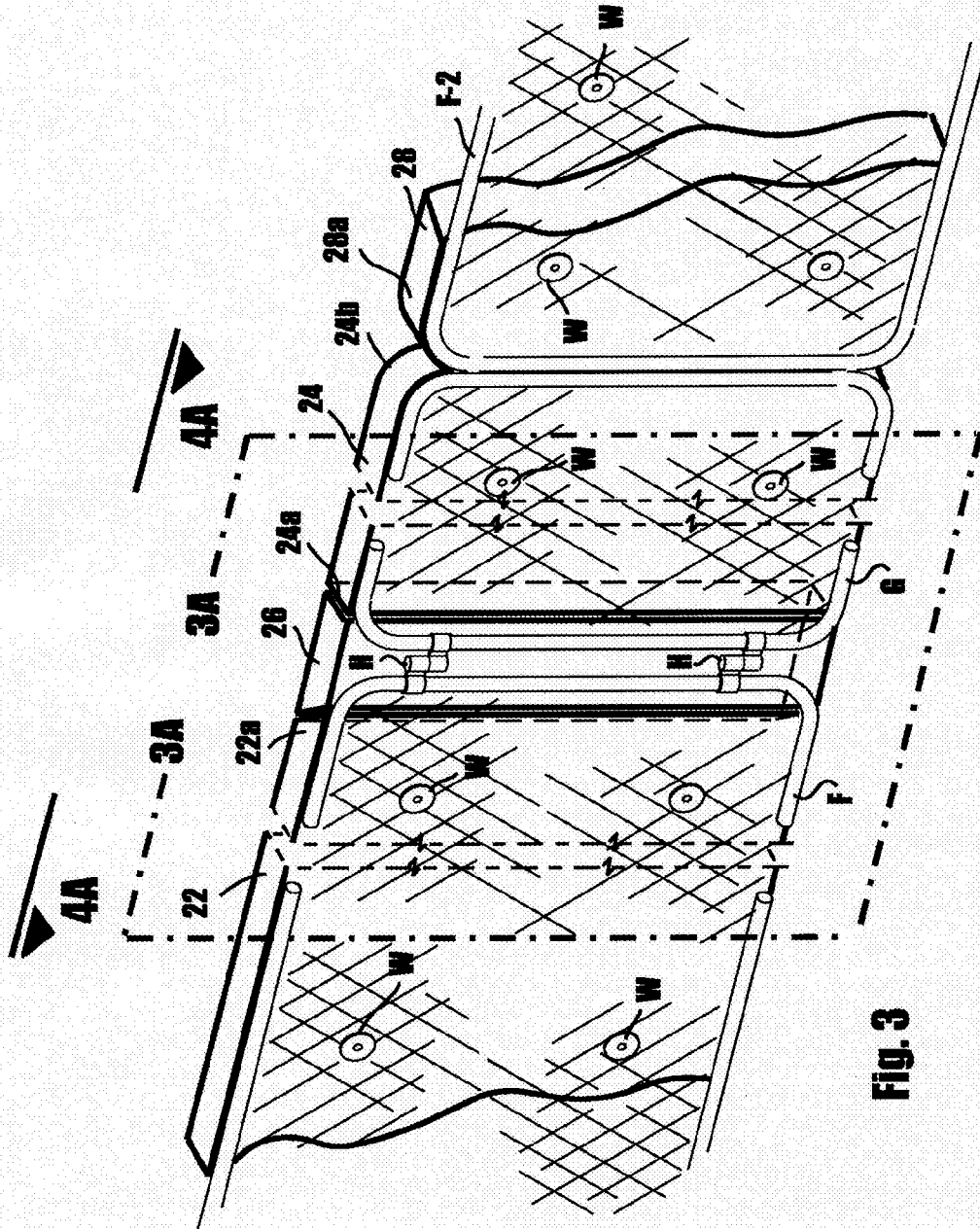

FIG. 2



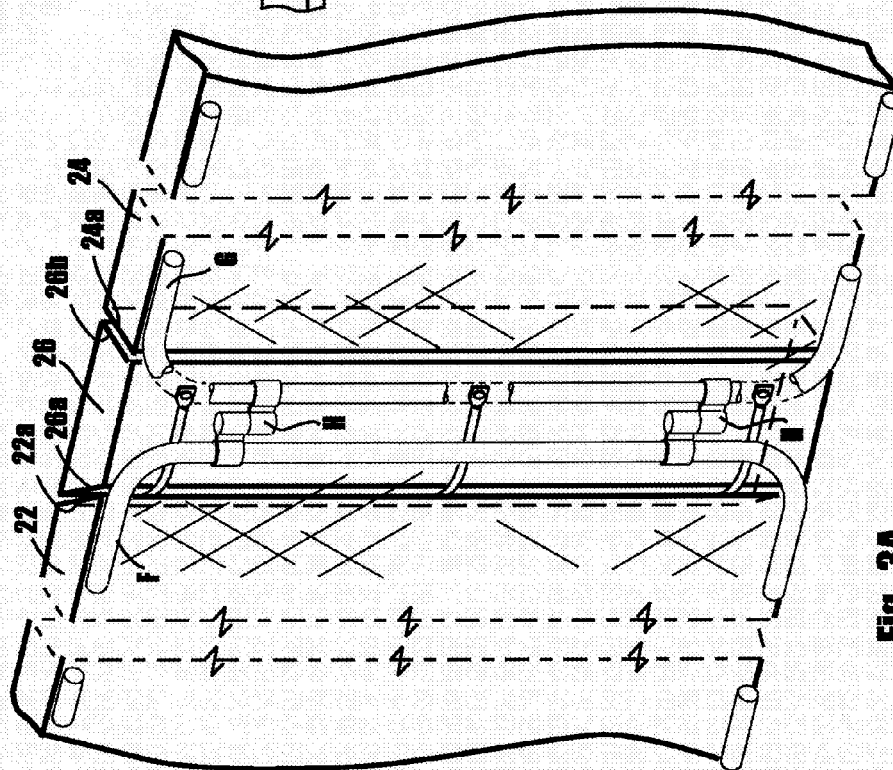

FIG. 3A

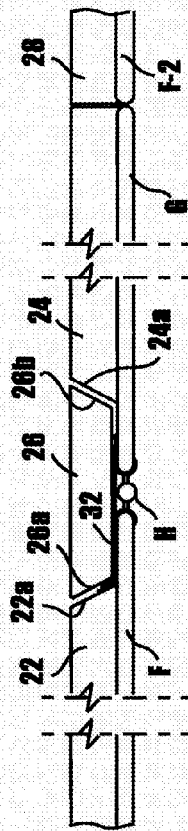

FIG. 4A

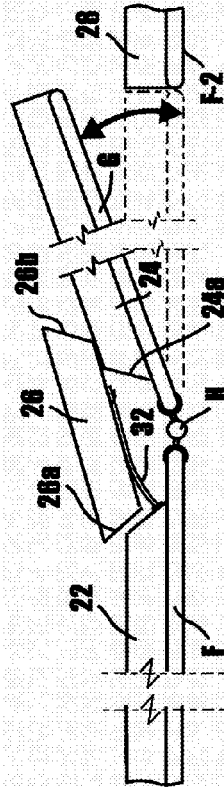
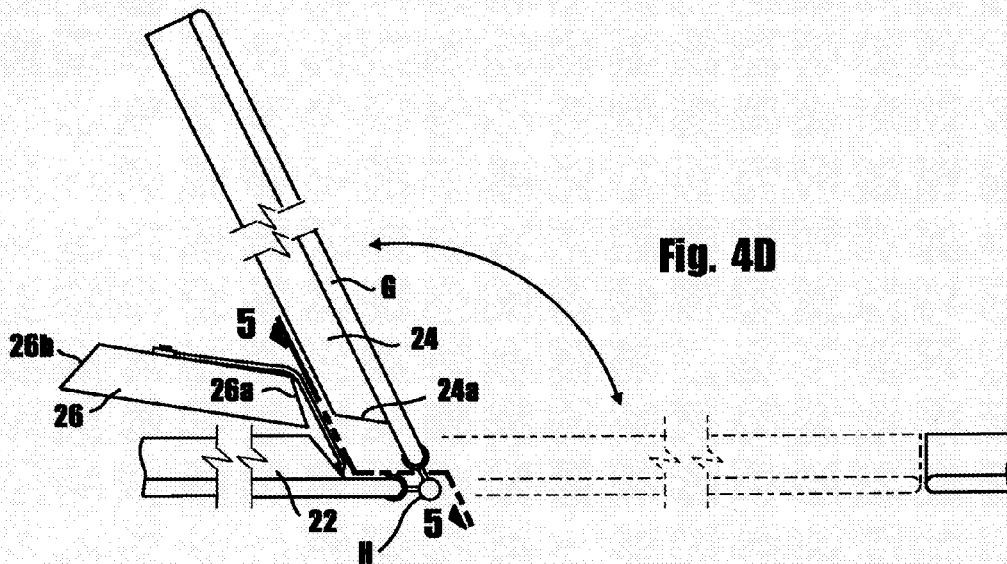
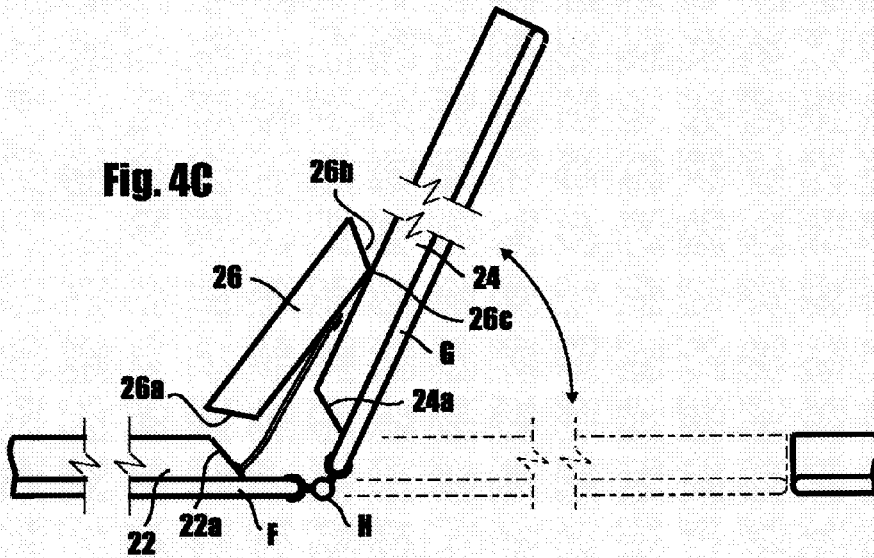

FIG. 4B



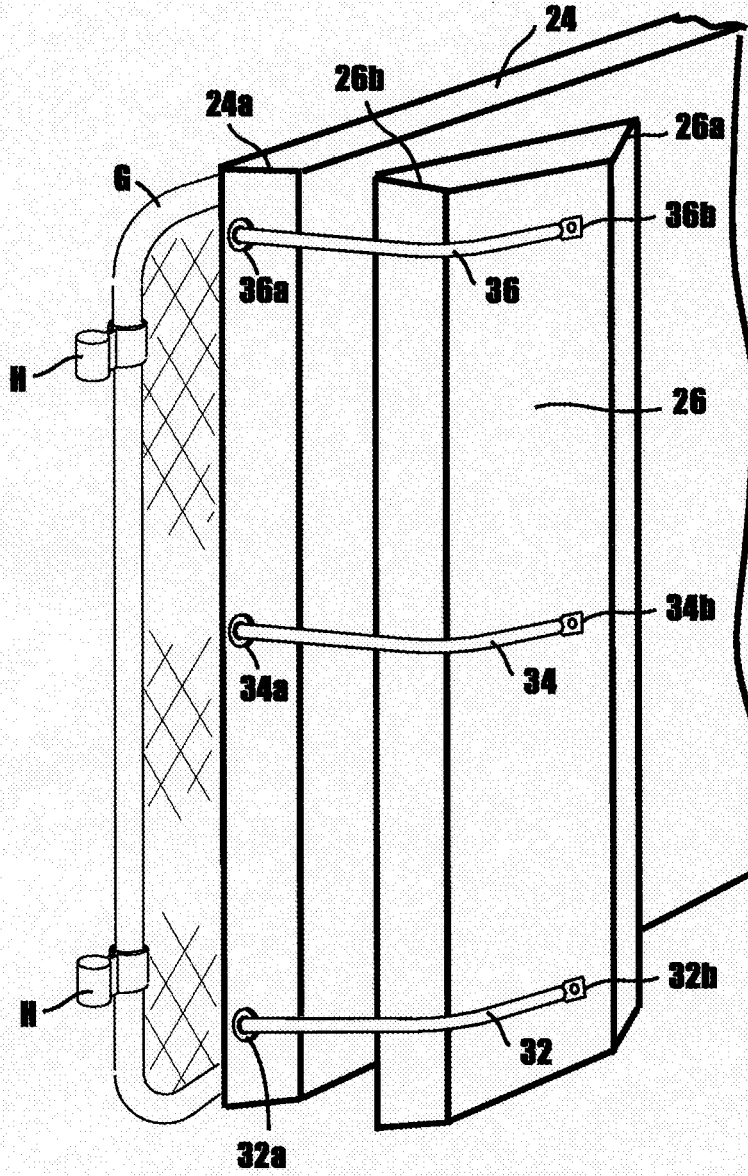

Fig. 5

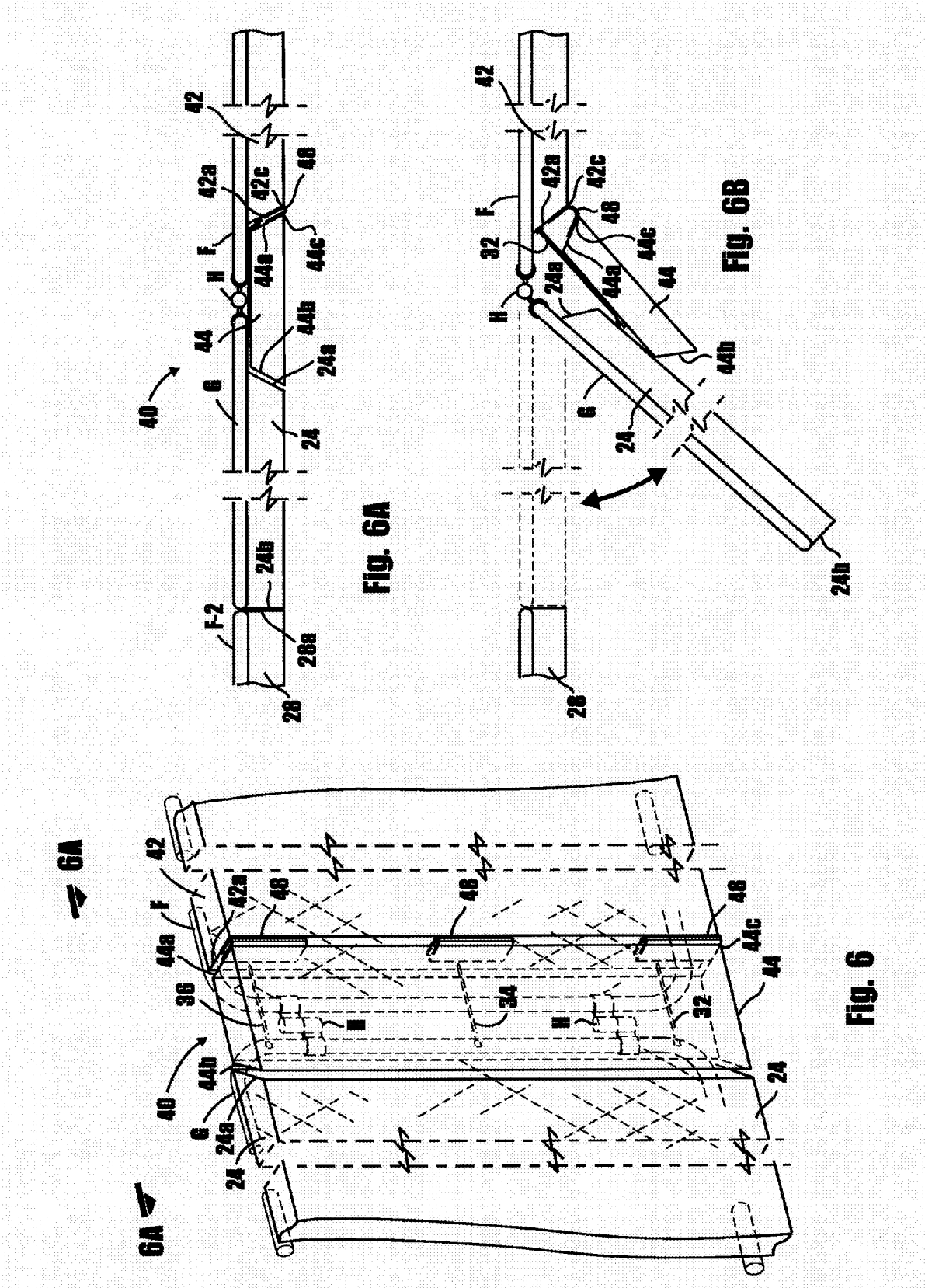
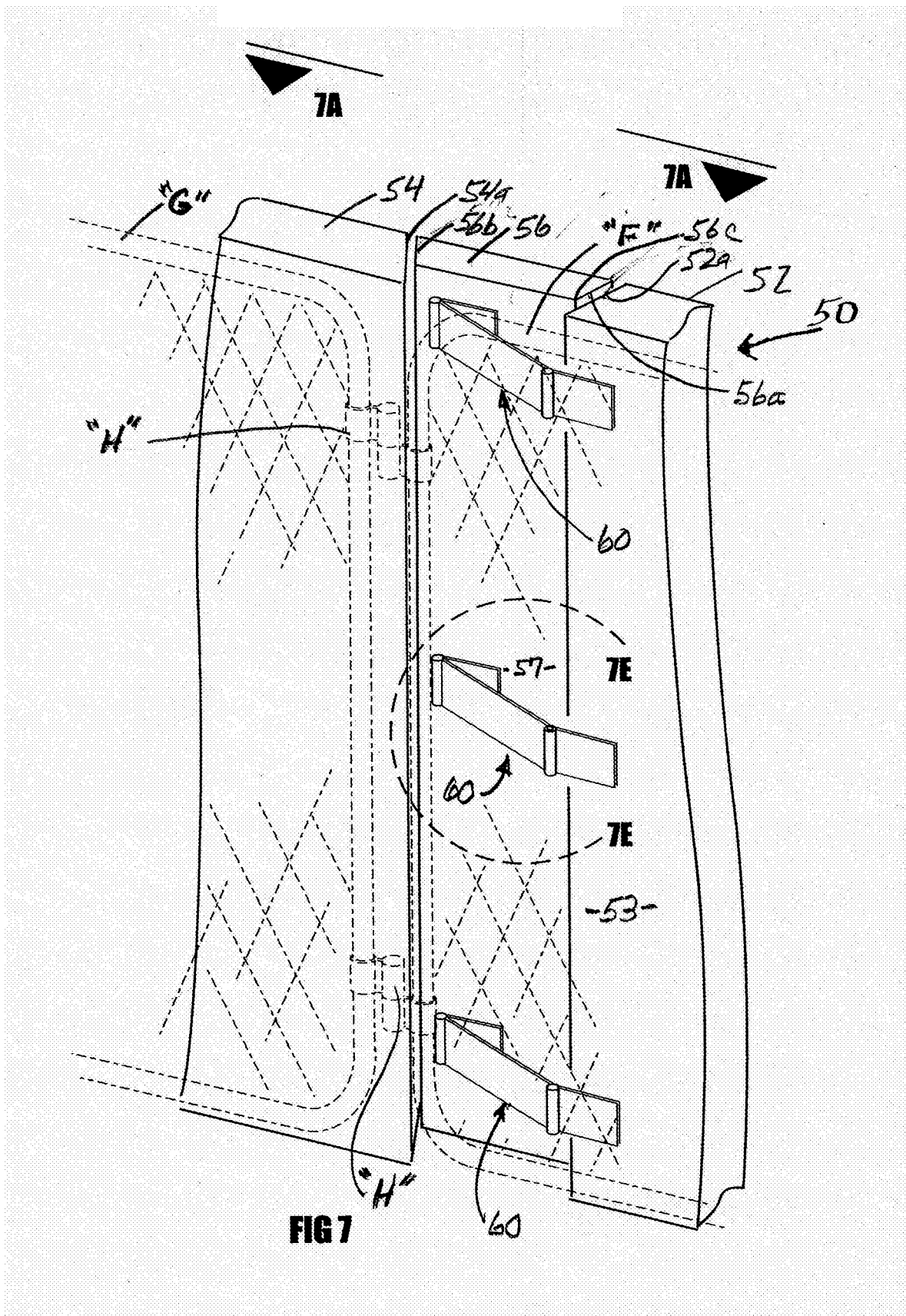

FIG. 6A

FIG. 6B

FIG. 6



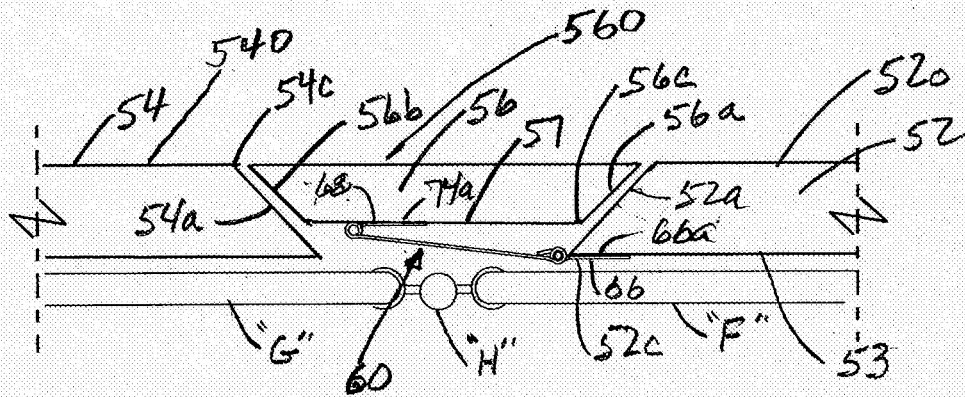

FIG 7A

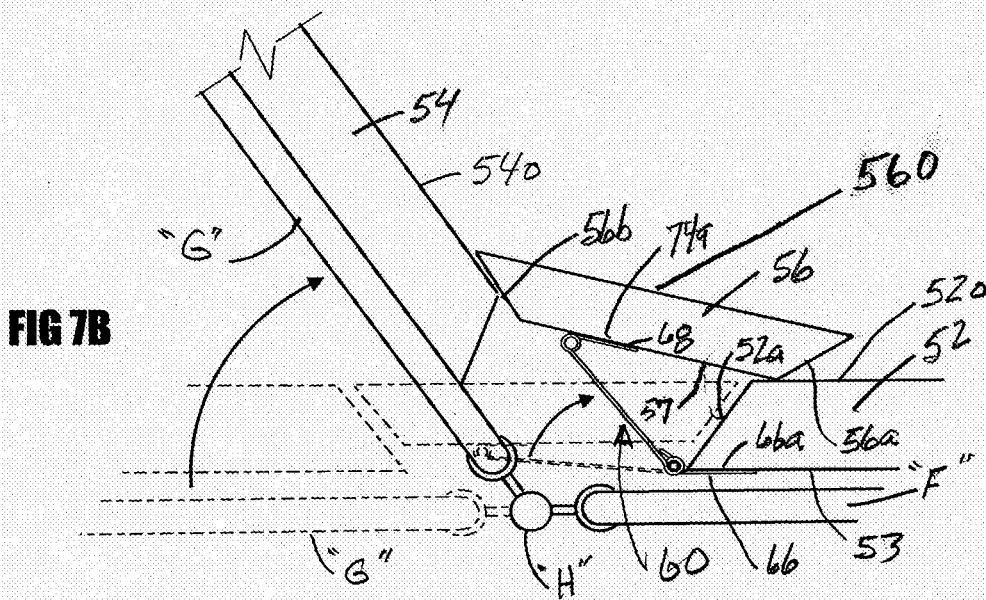
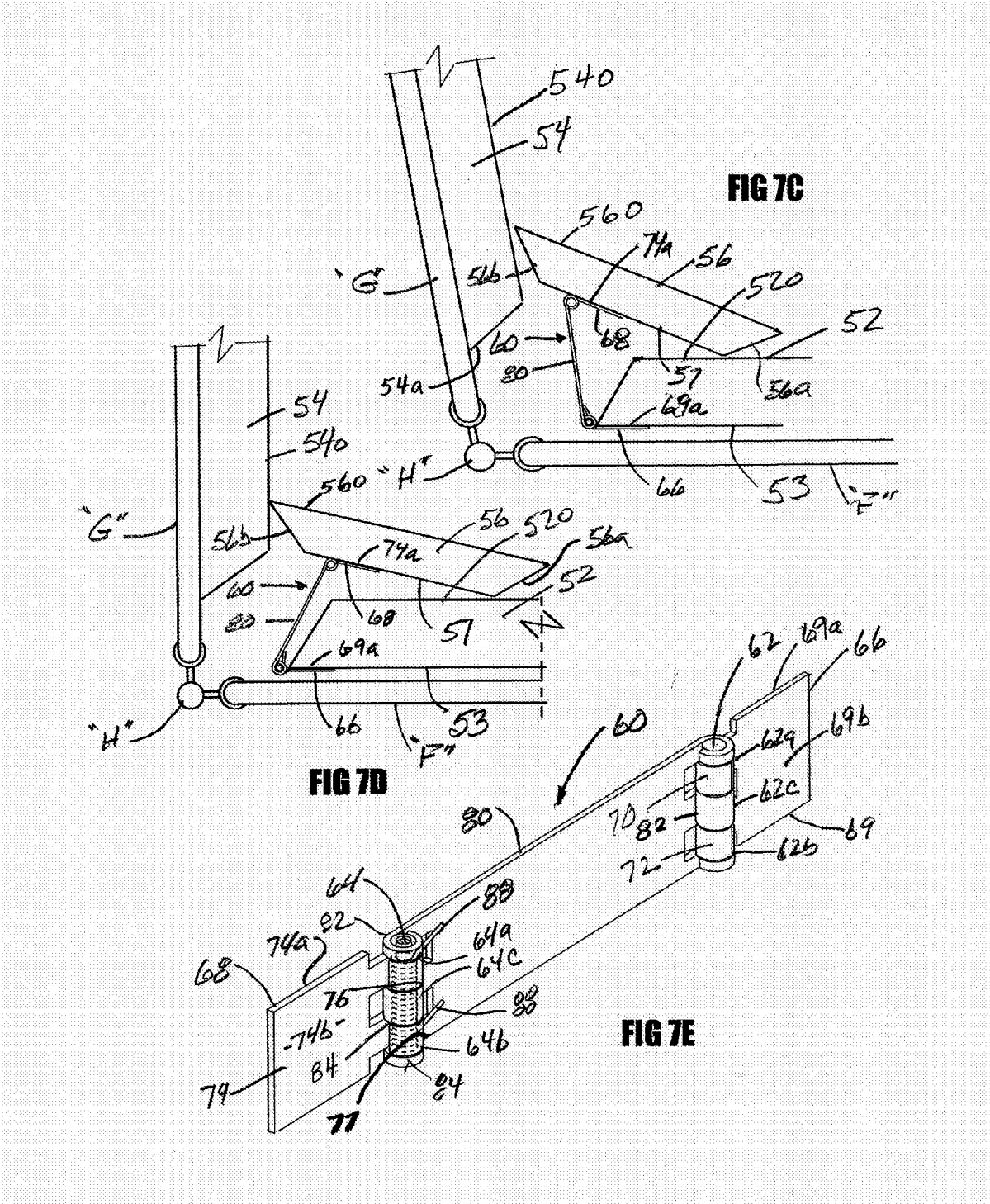

FIG 7B



PROTECTIVE PADDING**CROSS-REFERENCE TO RELATED APPLICATIONS**

[0001] This is a Continuation-In-Part of co-pending U.S. Ser. No. 12/799,022 filed Apr. 16, 2010.

STATEMENT REGARDING FEDERALLY SPONSORED RESEARCH OR DEVELOPMENT

[0002] Not Applicable

INCORPORATION-BY-REFERENCE OF MATERIAL SUBMITTED ON A COMPACT DISC

[0003] Not Applicable

BACKGROUND OF THE INVENTION

[0004] 1. Field of Invention

[0005] The present invention relates generally to protective padding. More particularly, the invention concerns a novel protective padding assembly for covering a section of a barrier, such as a fence having a swinging gate, the protective padding assembly including a fence covering section, a gate covering section and an intermediate, wedge shaped section for covering the gate hinge in the manner that will not interfere with opening and closing the gate.

[0006] 2. Description of Related Art Including Information Disclosed Under 37 CFR 1.97 and 1.98

[0007] Protective padding of various kinds has long been used to cover perimeter fences at a number of different types of sports venues including baseball fields, soccer fields, football fields and the like. Perimeter fences typically include a series of posts set in the ground with a fencing material, such as chain-link fencing, spanning the posts. Typically, the prior art protective padding comprises plywood panels covered with vinyl encased, high impact foam that are connected to the chain link fence using plastic washers that are bolted to the back of the protective padding assemblies.

[0008] To provide a gate in an opening of the fence, a pipe work frame the size of the opening is typically hinged to one side of the opening. A latch mechanism of some type is then attached to the opposite side of the opening and is used to maintain the gate in the closed position. Covering the gate and the gate hinges with a protective padding in a manner such that the gate can be freely opened and closed has long presented a very troublesome problem. The thrust of the present invention is to solve this troublesome prior art problem by providing a uniquely constructed protective padding assembly that includes a gate pad and a cooperatively associated generally wedge shaped insert of novel design that covers the gate hinge. When the gate is closed, the wedge shaped insert cooperates with the gate pad and with the pad covering the section of fence located adjacent the gate to provide a continuous length of protective pad.

BRIEF SUMMARY OF THE INVENTION

[0009] It is an object of the present invention to provide a novel protective padding assembly for covering a section of a barrier having a swinging gate, the protective padding assembly including a barrier covering section, a gate covering section and an intermediate, wedge shaped portion for covering the gate hinge in the manner that will not interfere with opening and closing the gate.

[0010] Another object of the invention is to provide a protective padding assembly of the aforementioned character that is of a simple construction and one that is easy to interconnect with a conventional section of a barrier such as a fence having a swinging gate.

[0011] Another object of the invention is to provide a protective padding as described in the preceding paragraphs that effectively prevents injury to an athlete accidentally running into the swinging gate and the hinge portion of the swinging gate.

[0012] Another object of the invention is to provide a protective padding of the character described that is sturdy in use and attractive in appearance.

[0013] Another object of the invention is to provide a protective padding of the class described in the preceding paragraphs that is inexpensive to manufacture, is reliable in operation and has a relatively long, useful life.

BRIEF DESCRIPTION OF SEVERAL VIEWS OF THE DRAWINGS

[0014] FIG. 1 is a generally perspective, exploded view showing one form of the protective padding apparatus of the invention shown spaced apart from the chain-link fence and swinging gate to which the protective padding apparatus is to be attached.

[0015] FIG. 2 is a generally perspective, front view, similar to FIG. 1, but showing the protective padding apparatus of the invention interconnected with the chain-link fence and swinging gate.

[0016] FIG. 3 is a generally perspective, rear view, similar to FIG. 2 showing the protective padding apparatus of the invention interconnected with the chain-link fence and swinging gate.

[0017] FIG. 3A is a generally perspective, enlarged view of the area designated in FIG. 3 as 3A-3A.

[0018] FIG. 4A is a view taken along lines 4A-4A of FIG. 3.

[0019] FIG. 4B is a view similar to FIG. 4A, but showing the gate partially open.

[0020] FIG. 4C is a view similar to FIG. 4B, but showing the gate opened further.

[0021] FIG. 4D is a view similar to FIG. 4C but showing the gate completely open.

[0022] FIG. 5 is a generally perspective, fragmentary view showing the relative positions of the gate pad and the intermediate wedge portion when the gate is in the open position and showing the elastomeric, wedge biasing cords of the apparatus in an extended configuration.

[0023] FIG. 6 is a generally perspective, fragmentary view of an alternate form of the protective padding apparatus of the invention.

[0024] FIG. 6A is a view taken along lines 6A-6A of FIG. 6.

[0025] FIG. 6B is a view similar to FIG. 6, but showing the gate partially open.

[0026] FIG. 7 is a generally perspective, exploded view of still another form of the protective padding apparatus of the invention shown spaced apart from the chain-link fence and swinging gate to which the protective padding apparatus is to be attached.

[0027] FIG. 7A is a view taken along lines 7A-7A of FIG. 7.

[0028] FIG. 7B is a view similar to FIG. 7A, but showing the gate partially open.

[0029] FIG. 7C is a view similar to FIG. 7B, but showing the gate opened further.

[0030] FIG. 7D is a view similar to FIG. 7C but showing the gate completely open.

[0031] FIG. 7E is a view of the area designated in FIG. 7 as 7E-7E showing the hinge assembly of the protecting padding apparatus of this latest form of the invention.

DETAILED DESCRIPTION OF THE INVENTION

[0032] Referring to the drawings and particularly to FIGS. 1 and 2, one form of the protective padding assembly of the present invention is there shown and generally designated by the numeral 20. Protective padding assembly 20 is specially designed for covering a section of a barrier, such as a chain-link fence comprising a continuous barrier portion, such as the chain-link fence portion "F" and a swinging gate such as a chain-link swinging gate "G" that is connected to the chain-link fence portion by a pair of spaced apart hinges "H". It is to be understood that, while the barrier is shown in the drawings as a chain link fence, the protective padding assembly can be used in connection with various types of barriers, such as wooden fences, partition walls and like structures that include a hingeable connected swinging gate.

[0033] As illustrated in FIGS. 1 and 2 of the drawings, protective padding assembly 20 here comprises a first section 22 that is connected to the continuous chain-link fence portion "F", a second section 24 that is connected to the chain-link swinging gate, and an intermediate portion 26 that is disposed between the first and second sections. First section 22 has a tapered end portion 22a and second section 24 has a tapered end portion 24a. As best seen by referring to FIGS. 3A and 4A, intermediate portion 26 has a first tapered edge 26a that is disposed in close proximity with tapered edge 22a of first section 22 when the intermediate portion 26 is in the first gate closed position shown in FIG. 4A. Similarly, intermediate portion 26 has a second tapered edge 26b that is disposed in close proximity with tapered edge 24a of first section 24 when the intermediate portion 26 is in the first gate closed position. As indicated in the drawings, when the gate is closed, end portion 24b of the gate pad is in close proximity with the end portion 28a of the protective pad 28 that is affixed to the fence section "F-2" that is located proximate the free end of the gate "G".

[0034] As illustrated in FIGS. 4B, 4C, 4D and 5, and as will be discussed in greater detail in the paragraphs which follow, as the gate "G" is opened, intermediate portion 26 is movable between the first gate closed position wherein it is overlying the hinges "H" and a second position wherein it is spaced apart from the hinges.

[0035] As is conventional in the prior art, each of the protective pad portions 22, 24 and 26 comprise a high impact foam pad having a vinyl coating. As is also conventional in the prior art, each of the protective pad portions is connected to a plywood panel that provides rigidity to the protective pad assemblies. As indicated in FIG. 3 of the drawings, the protective pad assemblies are interconnected with the sections of chain-link fence and with the chain-link gate by means of plastic washers "W" that are bolted to the back of the protective padding assemblies.

[0036] Referring particularly to FIG. 4B of the drawings, as the gate is swung into the open position shown in FIG. 4B, tapered edge 26b of intermediate portion 26 will slide up tapered end portion 24a of first section 24 and will move into the position shown in FIG. 4B where it rests on the outer

surface of first section 24 and is spaced apart from the hinges "H". As the gate is further opened into the position shown in FIG. 4C of the drawings, the inner edge 26c of the intermediate portion will slide along the outer surface of first section 24 against the urging of the biasing means of the invention, into the position shown in FIG. 4C. As best seen in FIG. 5 of the drawings, this important biasing means of the invention, which yieldably resists movement of said intermediate portion away from its at-rest position shown in FIG. 4A, here comprises three vertically spaced apart, stretchable elastomeric cords. More particularly, the biasing means of the invention comprises an elongate, stretchable first cord 32 having a first end 32a connected to a tapered end portion of first section 22 and a second end 32b connected to the inner surface of intermediate portion 26. The biasing means also comprises an elongate, stretchable second cord 34 having a first end 34a connected to a tapered end portion of first section 22 and a second end 34b connected to the inner surface of intermediate portion 26. Additionally, the biasing means here comprises an elongate, stretchable third cord 36 having a first end 36a connected to a tapered end portion of first section 22 and a second end 36b connected to the inner surface of intermediate portion 26. While the biasing means is here shown as comprising a plurality of stretchable, elastomeric cords, it is to be understood that the biasing means could be provided in several forms including coil springs, torsion springs and a variety of other spring constructions.

[0037] As the gate continues to be opened into the position shown in FIG. 4D of the drawings, the intermediate portion 26 will be forced downwardly against the further urging of the biasing means of the invention in a direction toward the outer surface of the first section into the position shown in FIG. 4C. As can be observed by a study of FIG. 4D, when the intermediate portion 26 has been moved into the position shown in FIG. 4D, each of the stretchable elastomeric cords has been significantly stretched from its at-rest position. Accordingly, when the gate "G" is once again moved into the closed position, the elastomeric cords 32, 34 and 36 will act upon the intermediate portion 26, positively urging it into its starting position as shown in FIGS. 3A and 4A of the drawings.

[0038] Referring next to FIGS. 6A and 6B of the drawings, an alternate form of the protective padding assembly of the present invention is there shown and generally designated by the numeral 40. This latest form of the invention is similar in many respects to the earlier described embodiment and like numerals are used in FIGS. 6, 6A and 6B to identify like components. As in the earlier described embodiment of the invention, protective padding assembly 40 is specially designed for covering a barrier such as a section of chain-link fence comprising a chain-link fence portion "F" and a chain-link swinging gate "G" that is connected to the chain-link fence portion by a pair of spaced apart hinges "H".

[0039] As illustrated in FIGS. 6A and 6B of the drawings, protective padding assembly 40 here comprises a first section 42 that is connected to the chain-link fence portion "F", a second section 24 that is connected to the chain-link swinging gate, and an intermediate portion 44 that is disposed between the first and second sections. First section 42 has a tapered end portion 42a that terminates in an outer edge portion 42c. Similarly, second section 24 has a tapered end portion 24a. As best seen by referring to FIG. 6A, intermediate portion 44 has a first tapered edge 44a that is disposed in close proximity with tapered edge 42a of first section 42 when the intermediate portion 44 is in the first gate closed position shown in

FIG. 6A. Similarly, intermediate portion 44 has a second tapered edge portion 44b that is disposed in close proximity with tapered edge 24a of first section 24 when the intermediate portion 44 is in the first gate closed position. The tapered edge 44a of intermediate portion 44 terminates in an outer edge portion 44c. As indicated in the drawings, when the gate is closed, end portion 24b of the gate pad is in close proximity with the end portion 28a of the protective pad 28 that is affixed to the fence section "F-2" that is located proximate the free end of the gate "G" (FIG. 6A).

[0040] As before, as the gate "G" is opened, intermediate portion 44 is movable between the first gate closed position wherein it is overlying the hinges "H" and a second position wherein it is spaced apart from the hinges (FIG. 6B).

[0041] As is conventional in the prior art, each of the protective pad portions 42, 24 and 44 comprise a high impact foam pad having a vinyl coating. As is also conventional in the prior art, each of the protective pad portions is connected to a plywood panel that provides rigidity to the protective pad assemblies. Similarly, the protective pad assemblies are interconnected with the sections of chain-link fence and with the chain-link gate by means of plastic washers that are bolted to the back of the protective padding assemblies.

[0042] The primary difference between this latest embodiment of the invention and the earlier described embodiment resides in the fact that the outer edge portions of the first section 42 and of the intermediate section 44 are hingeably interconnected. More particularly, outer edge portion 42c of first section 42 is hingeably interconnected with outer edge portion 44c of intermediate section 44. While these sections can be hingeably interconnected in various ways, they are here interconnected by a plurality of vertically spaced apart fabric hinges 48 (FIG. 6).

[0043] Referring particularly to FIG. 6B of the drawings, as the gate is swung into the open position there shown, tapered edge 44b of intermediate portion 44 will slide up tapered end portion 24a of first section 24 and will move into the position shown in FIG. 6B, where it rests on the outer surface of first section 24 and is spaced apart from the hinges "H". As the intermediate portion 44 moves into the position shown in FIG. 6B, the outer edge of section 44 will pivot about the outer edge of the first section 42, in the manner illustrated in FIG. 6B.

[0044] Once again, biasing means are provided to yieldably resist movement of intermediate portion 44 away from its at-rest position as shown in FIG. 6A. This important biasing means which is substantially identical in construction and operation to the previously described biasing means, here comprises three vertically spaced apart, stretchable elastomeric cords 32, 34 and 36 that are connected in the manner previously described and that operate in the manner previously described. While the biasing means is here shown as comprising a plurality of stretchable, elastomeric cords, it is to be understood that the biasing means could be provided in several forms including coil springs, torsion springs and a variety of other spring constructions.

[0045] As the gate continues to be opened, the intermediate portion 44 will be forced downwardly against the further urging of the biasing means of the invention in a direction toward the outer surface of first section 42. When the intermediate portion 44 has been moved into this position, each of the stretchable elastomeric cords will have been significantly stretched from the at-rest position. Accordingly, when the gate "G" is once again moved into the closed position, the

elastomeric cords 32, 34 and 36 will act upon the intermediate portion 44, positively urging it into its starting position as shown in FIG. 6A of the drawings.

[0046] Referring next to FIG. 7 of the drawings, still another form of the protective padding assembly of the present invention is there shown and generally designated by the numeral 50. This latest form of the invention is similar in many respects to the earlier described embodiment and like numerals are used in FIG. 7 and FIGS. 7A-7E to identify like components. As in the earlier described embodiment of the invention, protective padding assembly 50 is specially designed for covering a barrier such as a section of chain-link fence comprising a chain-link fence portion "F" and a chain-link swinging gate "G" that is connected to the chain-link fence portion by a pair of spaced apart hinges "H".

[0047] As illustrated in FIGS. 7 and 7A of the drawings, protective padding assembly 50 here comprises a first section 52 having an inner surface 53 that is connected to the chain-link fence portion "F" (shown in phantom lines in FIG. 7), a second section 54 that is connected to the chain-link swinging gate "G" (shown in phantom lines in FIG. 7) and an intermediate portion 56 that is disposed between the first and second sections. As indicated in FIG. 7, first and second sections 52 and 54 are of a first width and intermediate portion 56 is of a second width less than the first width.

[0048] First section 52 has a tapered end portion 52a, while second section 54 has a tapered end portion 54a. The tapered edge 52a of section 52 terminates in an inner edge portion 54c. Similarly, the tapered edge 54a of section 54 terminates in an outer edge portion 54c.

[0049] Intermediate portion 56 has an inner surface 57 and a first tapered edge 56a that is disposed in close proximity with tapered edge 52a of first section 52 when the intermediate portion is in the first gate-closed position shown in FIG. 7. Similarly, intermediate portion 56 has a second tapered edge portion 56b that is disposed in close proximity with tapered edge 54a of second section 54 when the intermediate portion 56 is in the first gate-closed position. The tapered edge 56a of intermediate portion 44 terminates in an inner edge portion 56c.

[0050] As before, as the gate "G" is opened, intermediate portion 56 is movable between the first gate-closed position, wherein it is overlying the hinges "H" and a second position, wherein it is spaced apart from the hinges (FIG. 7B).

[0051] As is conventional in the prior art, each of the protective pad portions 52, 54 and 56 comprise a high impact foam pad having a vinyl coating. As is also conventional in the prior art, each of the protective pad portions is connected to a plywood panel that provides rigidity to the protective pad assemblies. Similarly, the protective pad assemblies are interconnected with the sections of chain-link fence and with the chain-link gate by means of plastic washers that are bolted to the back of the protective padding assemblies.

[0052] The primary difference between this latest embodiment of the invention and the earlier described embodiment resides in the fact that the first section 52 and the intermediate section 56 of the protective padding assembly are hingeably interconnected by a plurality of vertically spaced-apart, uniquely configured metal hinge assemblies 60. More particularly, the inner surface 53 of first section 42 is hingeably interconnected with the inner surface 57 of intermediate section 56.

[0053] Referring particularly to FIG. 7E of the drawings, each of the hinge assemblies 60 can be seen to comprise a first

pivot pin **62** having an upper portion **62a**, a lower portion **62b**, a central portion **62c** and a second pivot pin **64** that is spaced apart from the first pivot pin. The second pivot pin also has an upper portion **64a**, a lower portion **64b** and a central portion **64c**.

[0054] Also forming a part of each hinge assembly **60** is first and second leaves **66** and **68**. The first leaf **66** includes a body portion **69** having inner and outer surfaces **69a** and **69b**. Connected to body portion **69** are vertically spaced apart knuckles **70** and **72** that are rotatably connected to the upper and lower portions of first pivot pin **62**. Second leaf **68** includes a body portion **74** having inner and outer surfaces **74a** and **74b**. Connected to body portion **74** are spaced apart knuckles **76** and **77** that are rotatably connected to the upper and lower portions of second pivot pin **64**. As indicated in FIG. 7A of the drawings, the outer surface **69a** of the body portion of first leaf **66** is connected to the inner surface **53** of the first section **52** of the protective padding assembly, while the outer surface **74a** of the body portion of second leaf **68** is connected to the inner surface **57** of the intermediate portion **56** of the protective padding assembly.

[0055] Spanning the body portions **69** and **74** of the first and second leaves **66** and **68** is an elongated connector leaf **80**. As illustrated in FIG. 7E, connector leaf **80** has a first knuckle **82** that is rotatably connected to the central portion **62c** of first pivot pin **62** and a second knuckle **84** that is rotatably connected to the central portion of the second pivot pin **64**. Circumscribing second pivot pin **64** are conventional torsion springs **88** that function to yieldably resist movement of the intermediate portion **56** of the protective padding assembly away from its at-rest position shown in FIG. 7A.

[0056] Turning to FIG. 7B of the drawings, as the gate is swung into the open position, the hinge assemblies will move into the position there shown and the tapered edges **56a** of intermediate portions **56** will slide up tapered end portions **52a** of first sections **52** and will move into the position shown in FIG. 7B where they rest on the outer surfaces **52o** of first sections **52** and are spaced apart from the hinges "H". As the intermediate portions **56** move into the position shown in FIG. 7B against the urging of springs **88**, the tapered edges **56b** of sections **56** will move into proximity with the outer surfaces **54o** of second sections **54**.

[0057] As the gate continues to be opened, the hinge assemblies will move into the position shown in FIG. 7C and the tapered edges **56a** and **56b** of intermediate portions **56** will slide along the outer surfaces of sections **52** and **54** into the position shown in FIG. 7C.

[0058] Continued movement of the gate to the fully open position shown in FIG. 7D, will cause the hinge assemblies to move against the urging of springs **88** into the position there shown and will cause the tapered edges **56a** of intermediate portions **56** to further slide along the outer surfaces of sections **52** into the position shown in FIG. 7D. At the same time, the tapered edges **56b** of intermediate portions **56** will slide inwardly along the outer surfaces **56o** of sections **56** into the position shown in FIG. 7D. When the opening forces being exerted against the gate cease, the springs **88** of the hinge assemblies will cause the hinge assemblies along with the intermediate portions **56** of the protective padding assembly, to automatically return to the starting position shown in FIG. 7A.

[0059] Having now described the invention in detail in accordance with the requirements of the patent statutes, those skilled in this art will have no difficulty in making changes

and modifications in the individual parts or their relative assembly in order to meet specific requirements or conditions. Such changes and modifications may be made without departing from the scope and spirit of the invention, as set forth in the following claims.

1. A protective padding assembly for covering a section of a barrier comprising a continuous portion and a swinging gate connected to the continuous portion by a hinge, said protective padding assembly comprising:

- (a) a first section connected to the continuous portion, said first section having an outer surface, an inner surface and a tapered edge;
- (b) a second section connected to the swinging gate, said second section having a tapered edge;
- (c) an intermediate portion disposed between said first and second sections, said intermediate portion having an outer surface, an inner surface and a first tapered edge disposed in close proximity to said tapered edge of said first section and a second tapered edge disposed in close proximity to said tapered edge of said second section; and
- (d) a hinge assembly interconnecting said first section and said intermediate portion, said hinge assembly comprising:
 - (i) a first pivot pin;
 - (ii) a second pivot pin spaced apart from said first pivot pin;
 - (iii) a first leaf having a first end pivotally connected to said first pivot pin and a body portion connected to said inner surface of said first section;
 - (iv) a second leaf having a first end pivotally connected to said second pivot pin and a body portion connected to said inner surface of said intermediate portion; and
 - (v) a connector leaf having a first end pivotally connected to said first pivot pin and a second end pivotally connected to said second pivot pin.

2. The protective padding assembly as defined in claim 1 in which said intermediate portion is movable between a first position overlying the hinge and a second position spaced apart from the hinge.

3. The protective padding assembly as defined in claim 2 in which said first and second sections are of a first width and in which said intermediate portion is of a second width less than said first width.

4. The protective padding assembly as defined in claim 2 in which said first section, said second section and said intermediate portion comprise a foam having a vinyl covering.

5. The protective padding assembly as defined in claim 2 in which each of said first section, said second section and said intermediate portion comprise a pad constructed from foam having a vinyl covering, said pad being connected to a plywood panel.

6. The protective padding assembly as defined in claim 2 further including a biasing spring carried by said second pivot pin for yieldably resisting the rotation of said connector leaf relative to said second pivot pin.

7. The protective padding assembly as defined in claim 2 in which said first pivot pin has upper and lower portions and in which said first leaf includes spaced apart knuckles rotatably connected to said upper and lower portions of said first pivot pin.

8. The protective padding assembly as defined in claim 7 in which said second pivot pin has a central portion and in which

said body portion of said second leaf includes spaced apart knuckles rotatably connected to said upper and lower portions of said second pivot pin.

9. The protective padding assembly as defined in claim **8** in which said connector leaf includes a first knuckle rotatably connected to said central portion of said first pivot pin and a second knuckle rotatably connected to said central portion of said second pivot pin.

10. A protective padding assembly for covering a section of a barrier comprising a continuous portion and a swinging gate connected to the continuous portion by a hinge, said protective padding assembly comprising:

- (a) a first section connected to the continuous portion, said first section having a first width, an outer surface, an inner surface and a tapered edge;
- (b) a second section connected to the swinging gate, said second section having a first width and a tapered edge;
- (c) an intermediate portion disposed between said first and second sections, said intermediate portion having a second width less than said first width, an outer surface, an inner surface and a first tapered edge disposed in close proximity to said tapered edge of said first section and a second tapered edge disposed in close proximity to said tapered edge of said second section; and
- (d) a hinge assembly interconnecting said first section and said intermediate portion, said hinge assembly comprising:
 - (i) a first pivot pin having a central portion;
 - (ii) a second pivot pin spaced apart from said first pivot pin, said second pivot pin having a central portion;
 - (iii) a first leaf having a first end pivotally connected to said first pivot pin and a body portion connected to said inner surface of said first section;
 - (iv) a second leaf having a first end pivotally connected to said second pivot pin and a body portion connected to said inner surface of said intermediate portion; and
 - (v) a connector leaf having a first knuckle rotatably connected to said central portion of said first pivot pin and a second knuckle rotatably connected to said central portion of said second pivot pin.

11. The protective padding assembly as defined in claim **10** in which said intermediate portion is movable between a first position overlying the hinge and a second position spaced apart from the hinge.

12. The protective padding assembly as defined in claim **10** in which said first section, said second section and said intermediate portion comprise a foam having a vinyl covering.

13. The protective padding assembly as defined in claim **10** further including a biasing spring carried by said second pivot pin for yieldably resisting the rotation of said connector leaf relative to said second pivot pin.

14. The protective padding assembly as defined in claim **10** in which said first pivot pin has upper and lower portions and in which said first leaf includes spaced apart knuckles rotatably connected to said upper and lower portions of said first pivot pin.

15. The protective padding assembly as defined in claim **14** in which said second pivot pin has a central portion and in

which said body portion of said second leaf includes spaced apart knuckles rotatably connected to said upper and lower portions of said second pivot pin.

16. The protective padding assembly as defined in claim **15** in which said connector leaf includes a first knuckle rotatably connected to said central portion of said first pivot pin and a second knuckle rotatably connected to said central portion of said second pivot pin.

17. A protective padding assembly for covering a section of a barrier comprising a continuous portion and a swinging gate connected to the continuous portion by a hinge, said protective padding assembly comprising:

- (a) a first section connected to the continuous portion, said first section having a first width, an outer surface, an inner surface and a tapered edge;
- (b) a second section connected to the swinging gate, said second section having a first width and a tapered edge;
- (c) an intermediate portion disposed between said first and second sections, said intermediate portion having a second width less than said first width, an outer surface, an inner surface and a first tapered edge disposed in close proximity to said tapered edge of said first section and a second tapered edge disposed in close proximity to said tapered edge of said second section; and
- (d) a hinge assembly interconnecting said first section and said intermediate portion, said hinge assembly comprising:
 - (i) a first pivot pin having upper and lower portions and a central portion;
 - (ii) a second pivot pin spaced apart from said first pivot pin, said second pivot pin having upper and lower portions and a central portion;
 - (iii) a first leaf having a first end pivotally connected to said first pivot pin and a body portion connected to said inner surface of said first section, said body portion of said first leaf having spaced apart knuckles rotatably connected to said upper and lower portions of said first pivot pin;
 - (iv) a second leaf having a first end pivotally connected to said second pivot pin and a body portion connected to said inner surface of said intermediate portion, said body portion of said first leaf having spaced apart knuckles rotatably connected to said upper and lower portions of said second pivot pin;
 - (v) a connector leaf having a first knuckle rotatably connected to said central portion of said first pivot pin and a second knuckle rotatably connected to said central portion of said second pivot pin; and
 - (vi) a biasing spring carried by said second pivot pin for yieldably resisting the rotation of said connector leaf relative to said second pivot pin.

18. The protective padding assembly as defined in claim **17** in which said intermediate portion is movable between a first position overlying the hinge and a second position spaced apart from the hinge.

* * * * *