

(19)  
(12)

(KR)  
(Y1)

(51) 。 Int. Cl. 7  
B60K 15/04

(45)  
(11)  
(24)

2003 05 23  
20-0314292  
2003 05 12

(21) 20-2003-0006520  
(22) 2003 03 05

(73) ( ) 825-5

(72) 2 111 1501

1 1가500-1 3-410

(74)  
:  
가 :

(54)

가 , 가 ; 가 ;  
, 가 ; 가 ;  
, 가 , 가 ;  
가 , 가 ,

, , , ,

1

2

가

3

4

5

6

7

가

8

<

>

10 : 11 :

12 : 13 :

14 : 20 :

21 : 22 :

30 : 40 :

41 : 50 :

51 : 52 :

60 : 70 :

80 : 81 :

가

가

가

( 20-0190614 )

가

(STEEL PIPE)

가

가

가

가

가

가

가

가

가

가

가

(11)

,가 가

(13)

(11) (70)가 ,  
(STEEL PIPR) .

(12) (11) (14) (12)  
(11) .

(12) (11) .

, (12) (11)

, (11) (12) (12)

) (11) (11) . (12) (12)

(80) (20) (70)가 , (30)

(20) (80) .

, (10) (11) (21) , (21) (80)

, (10) (11) (22) , (80) 가 (11)

, (22) (81)

, (70) (20) (80)

(50)

(50)

, (12) (30) (51) (52)

, (80) (52)

, (10) (80) (52) , (52)

(51)

(30) (10) (11) (70)

, (70)

(30) (70) (10) (40)

(30)

, 가 가 ,

, 가 , 가

(40) (30) (70)가 .

(40)

(30) , (40) (70)가

(30) (70) (40) (30) 가 (41)

(10) (12) (11) (30) 가

(10) (30) (10) (12) (30)

(70) 가 (30) (10)

가 (60)

(70) (20) (80) (20)  
(30) (70)

(10) (12) (30) (12)  
(11) (14) (11)

가 가 가

(57)

1.

(70)가 (13) (11) ;  
(11) (11) (14) , (30) (12)

(11) (12) (80) 가 (11)  
(12) 가 (20);

2.

가 (30) 1 (10) (12) (30)  
(30) (40)

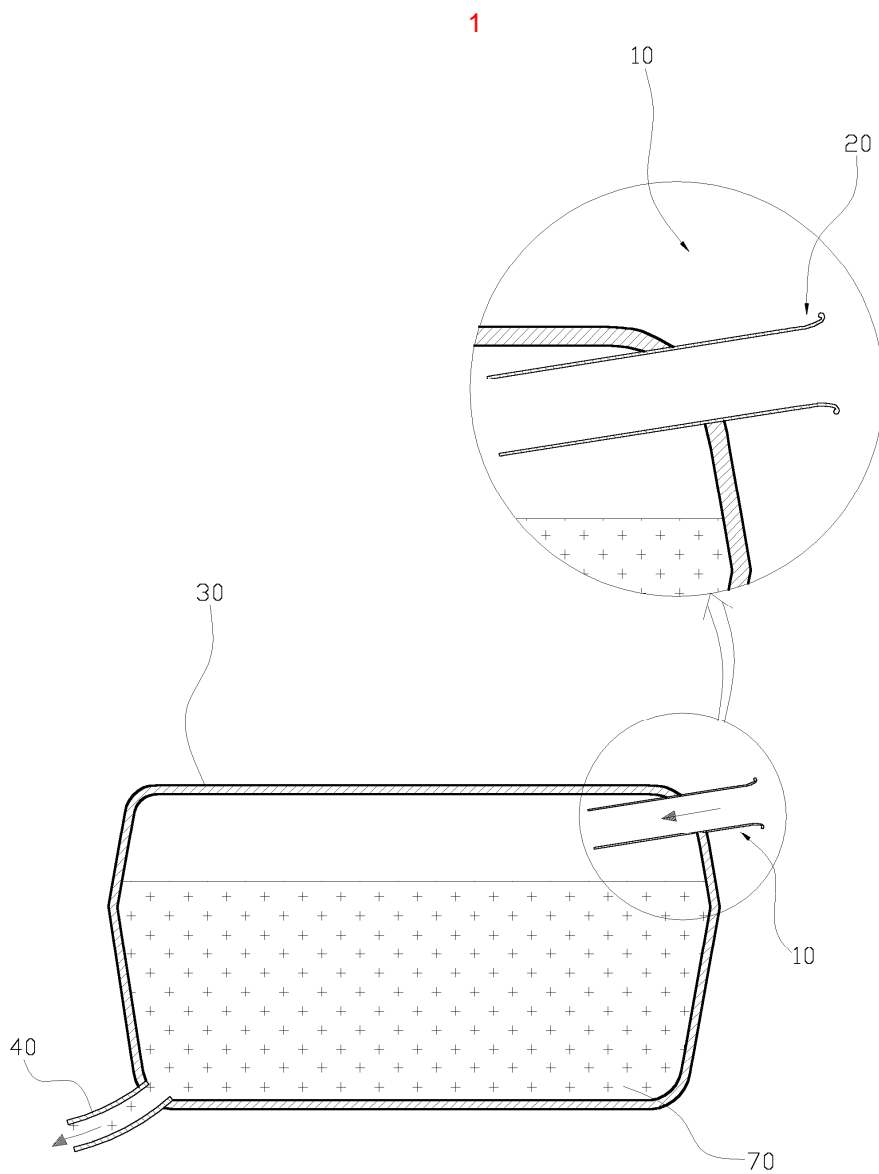

2

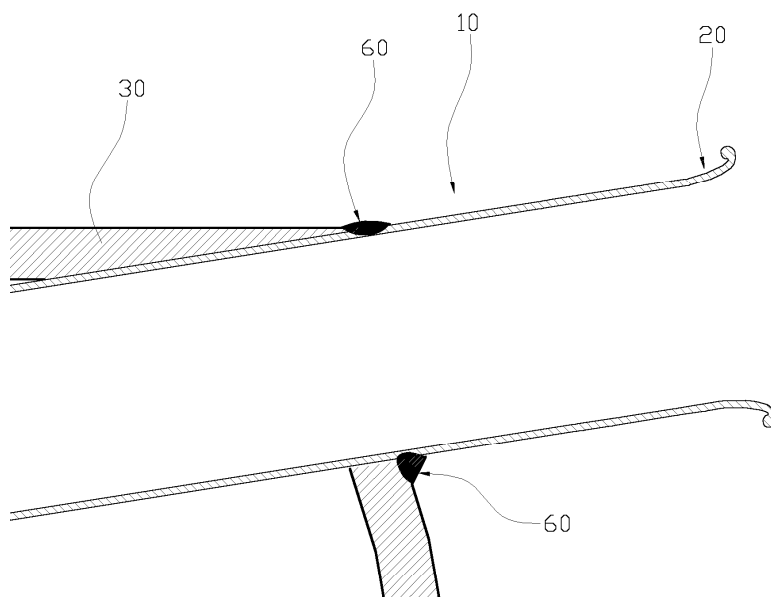

3

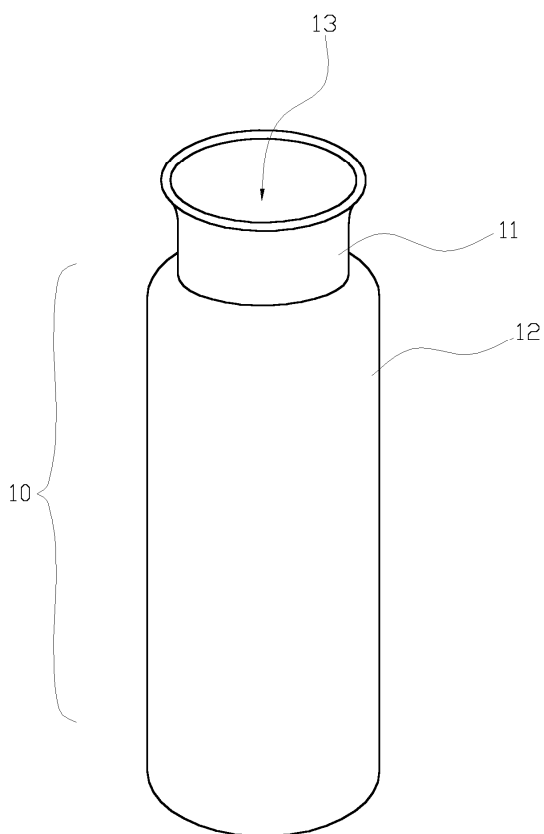

4

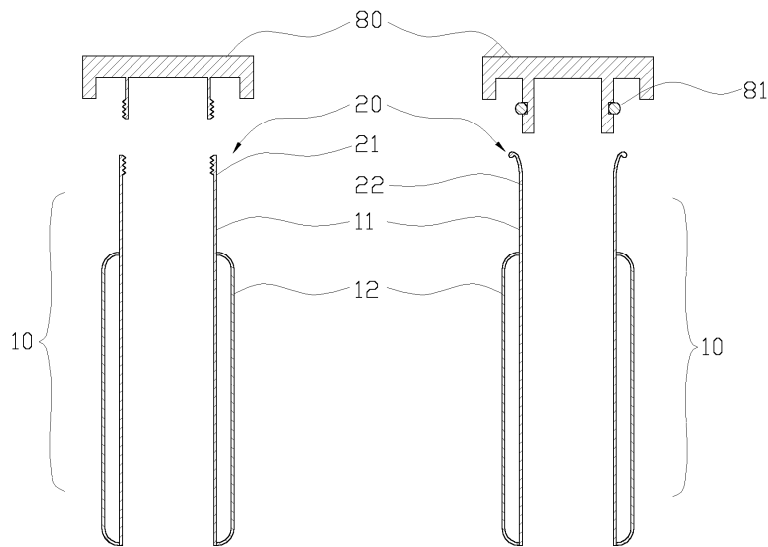

5

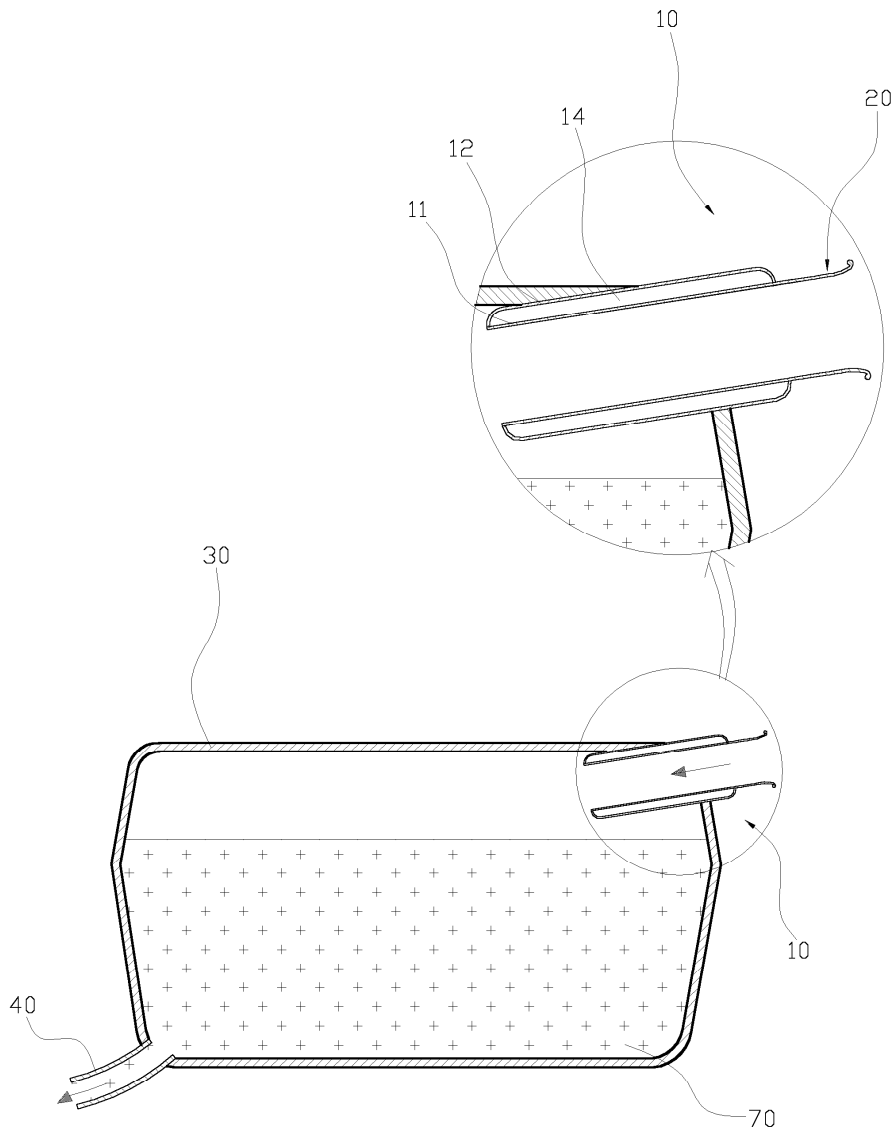



6

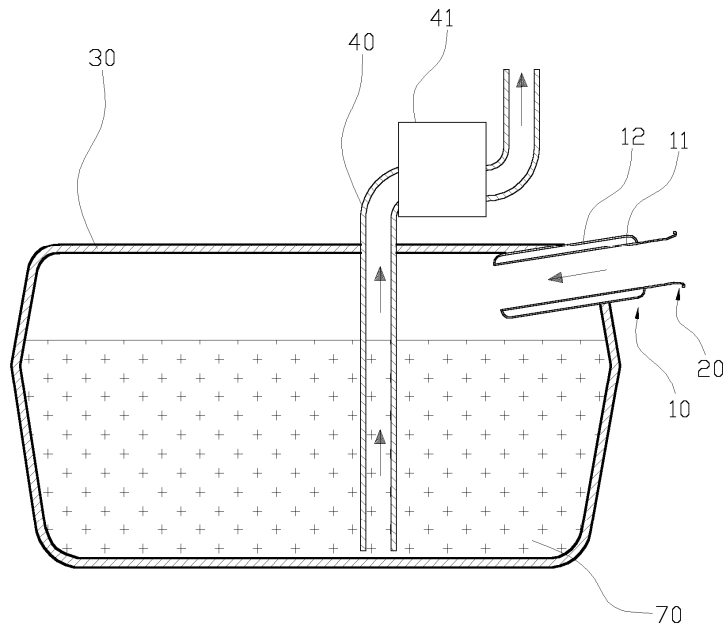

7

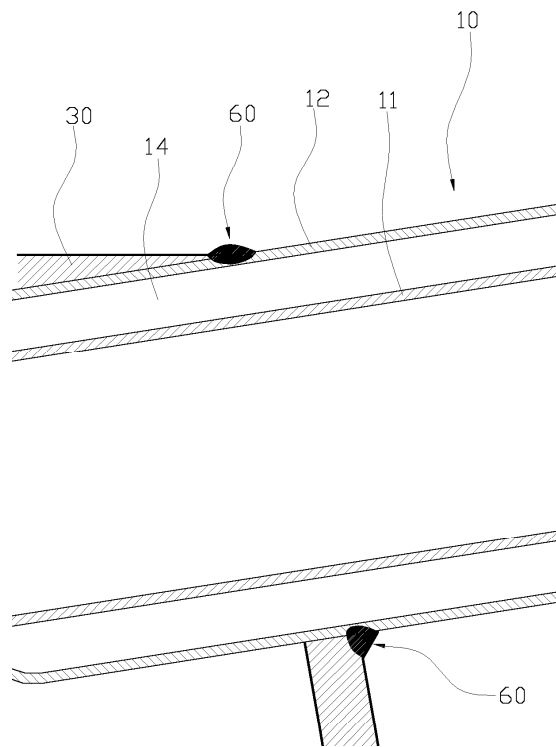

8

