

(12) INNOVATION PATENT
(19) AUSTRALIAN PATENT OFFICE

(11) Application No. **AU 2016101680 A4**

(54) Title
CONVENIENTLY-FIXED MOTOR BRUSH CARRIER

(51) International Patent Classification(s)
H02K 5/04 (2006.01)

(21) Application No: **2016101680** (22) Date of Filing: **2016.09.19**

(45) Publication Date: **2016.11.10**

(45) Publication Journal Date: **2016.11.10**

(45) Granted Journal Date: **2016.11.10**

(71) Applicant(s)
ZHEJIANG LINIX MOTOR CO., LTD.

(72) Inventor(s)
GUO, Qianqian

(74) Agent / Attorney
Admiral Trademarks & Patents Services, PO Box 767, Miranda, NSW, 1490

TITLE: CONVENIENTLY-FIXED MOTOR BRUSH CARRIER

Abstract

A conveniently-fixed motor brush carrier, comprising a brush carrier plate, electric brushes, brush holders and backing plates, the number of electric brushes, the number of brush holders and the number of backing plates being the same; a plurality of bugles is provided on the bottom side of the brush holder, and the bugles pass through the first brush holder fixing holes and the second brush holder fixing holes in turn; and each of the backing plates is limited between one brush holder and the brush carrier plate; the bugles comprise two spaced-apart front bugles and two spaced-apart rear bugles, the front bugles and the rear bugles being spaced apart one after another; each of the backing plates comprises two front first brush holder fixing holes and two rear front brush holder fixing holes; the second brush holder fixing holes comprise a front second brush holder fixing hole and a rear second brush holder fixing hole; each front bugle is bent after passing through one front first brush holder fixing hole and one front second brush holder fixing hole in turn, and each rear bugle is bent after passing through one rear first brush holder fixing hole and one rear second brush holder fixing hole in turn; and the bugles are bent to form a bent portion whose inner side is resisted against the brush carrier plate.

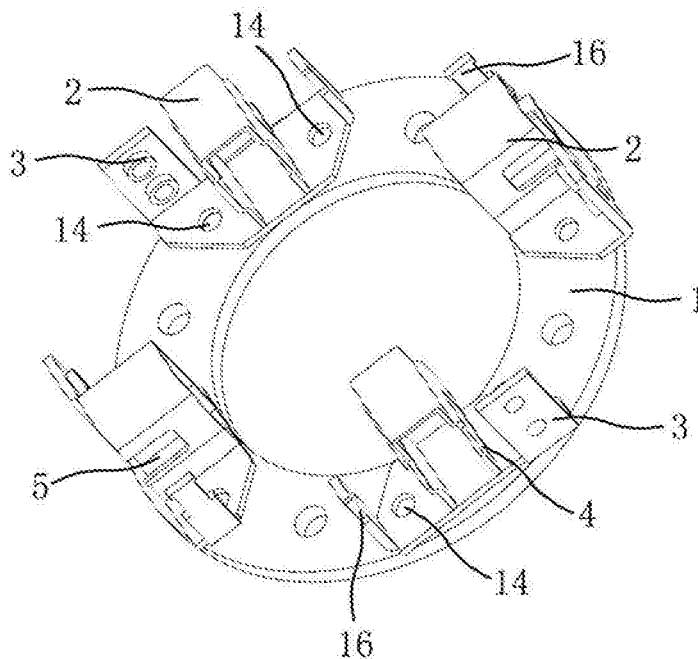

DESCRIPTION

CONVENIENTLY-FIXED MOTOR BRUSH CARRIER

Technical Field of the Invention

The present invention relates to a conveniently-fixed motor brush carrier.

Background of the Invention

A motor carrier brush includes a brush carrier plate, brush holders and electric brushes. The electric brushes are within the brush holders. However, there are burrs on the inner wall of the brush holes because of processing problems, and as a result, it is difficult to place the electric brushes inside the brush holders. Furthermore, the brush holders of the existing motor brush carrier are integrated with the brush carrier plate, and the brush carrier plate and the brush holders are both made of copper, so the production cost is high.

Summary of the Invention

An objective of the present invention is to provide a conveniently-fixed motor brush carrier which facilitates the mounting of electric brushes and can reduce the production cost.

To realize this purpose, the present invention employs the following technical solution. A conveniently-fixed motor brush carrier includes a brush carrier plate, a plurality of electric brushes, a plurality of brush holders and a plurality of backing plates, the number of electric brushes, the number of brush holders and the number of backing plates being the same; the electric brushes are within the brush holders; on left and right sides of each of the brush holders, convex structures protruding outward are formed so that the brush holder looks like a drum, and an open groove is formed on the convex structure of the brush holder; each of the backing plates is provided with a first brush holder fixing hole; second brush holder fixing holes, the position and number of which

are matched with those of the first brush holder fixing holes, are formed on the brushing carrier plate; a plurality of bugles is provided on the bottom side of the brush holder, and the bugles pass through the first brush holder fixing holes and the second brush holder fixing holes in turn; and each of the backing plates is limited between one brush holder and the brush carrier plate; the bugles include two spaced-apart front bugles and two spaced-apart rear bugles, the front bugles and the rear bugles being spaced apart one after another; each of the backing plates includes two front first brush holder fixing holes and two rear front brush holder fixing holes; the second brush holder fixing holes include a front second brush holder fixing hole and a rear second brush holder fixing hole; each front bugle is bent after passing through one front first brush holder fixing hole and one front second brush holder fixing hole in turn, and each rear bugle is bent after passing through one rear first brush holder fixing hole and one rear second brush holder fixing hole in turn; and the bugles are bent to form a bent portion whose inner side is resisted against the brush carrier plate.

The present invention has the advantages that the electric brushes are fixed conveniently and the product cost is low.

Brief Description of the Drawings

Fig. 1 is a structure diagram of the present invention, when the brush carrier plate, the brush holders and the backing plates are collaborated;

Fig. 2 is another structure diagram of the present invention, when the brush carrier plate, the brush holders and the backing plates are collaborated;

Fig. 3 is a structure diagram of a brush carrier plate of the present invention; and

Fig. 4 is a structure diagram of a backing plate of the present invention.

Detailed Description of the Invention

As shown in Fig. 1, Fig. 2, Fig. 3 and Fig. 4, a motor brush carrier of the

present invention includes one brush carrier plate 1, four electric brushes, four brush holders 2 and four backing plates 3; the electric brushes are within the brush holders 2; on left and right sides of each of the brush holders 2, convex structures 4 protruding outward are formed so that the brush holder looks like a drum, and an open groove 5 is formed on the convex structure 4 of the brush holder; each of the backing plates 3 is provided with a first brush holder fixing hole and a first backing plate mounting hole; second brush holder fixing holes, the position and number of which are matched with those of the first brush holder fixing holes, are formed on the brushing carrier plate 1; four bugles are provided on the bottom side of the brush holder 2, and the bugles are bent after passing through the first brush holder fixing holes and the second brush holder fixing holes in turn; and each of the backing plates 3 is limited between one brush holder 2 and the brush carrier plate 1. Wherein, the brush carrier plate 1 is made of plastic, and the brush holders 2 and the backing plates 3 are made of copper.

The four bugles include two spaced-apart front bugles 7 and two spaced-apart rear bugles 8, the front bugles 7 and the rear bugles 8 being spaced apart one after another; each of the backing plates 3 includes two front first brush holder fixing holes 9 and two rear front brush holder fixing holes 10; the second brush holder fixing holes include a front second brush holder fixing hole 11 and a rear second brush holder fixing hole 12; each front bugle 7 is bent after passing through one front first brush holder fixing hole 9 and one front second brush holder fixing hole 11 in turn, and each rear bugle 8 is bent after passing through one rear first brush holder fixing hole 10 and one rear second brush holder fixing hole 12 in turn; and the bugles each are bent to form a bent portion 13 whose inner side is resisted against the brush carrier plate 1.

Two first backing plate mounting holes 14 are formed on each of the backing plates 3, two second backing plate mounting holes 15 corresponding to the first backing plate mounting holes 14 are formed on the brush carrier

plate 1, and the backing plates 3 are fixed to the brush carrier plate 1 by blind rivets which pass through the first backing plate mounting holes 14 and the second backing plate mounting holes 15. The first backing plate mounting holes 14 are on the opposite left and right sides of the first brush holder fixing hole, and the second backing plate mounting holes 15 are on the opposite left and right sides of the second brush holder fixing hole.

On the backing plate 3, a spring fixing column 16 extending upward is formed. A scroll spring is fixed on the spring fixing column 16. The scroll spring is on one of left and right sides of the electric brush. An inner end of the scroll spring is a scroll structure while an outer end of the scroll spring is extended to the space between the electric brush and an inner wall of a motor cover.

Claims

1. A conveniently-fixed motor brush carrier, comprising a brush carrier plate, electric brushes, brush holders and backing plates, the number of electric brushes, the number of brush holders and the number of backing plates being the same; the electric brushes are within the brush holders; on left and right sides of each of the brush holders, convex structures protruding outward are formed so that the brush holder looks like a drum, and an open groove is formed on the convex structure of the brush holder; each of the backing plates is provided with a first brush holder fixing hole; second brush holder fixing holes, the position and number of which are matched with those of the first brush holder fixing holes, are formed on the brushing carrier plate; a plurality of bugles is provided on the bottom side of the brush holder, and the bugles pass through the first brush holder fixing holes and the second brush holder fixing holes in turn; and each of the backing plates is limited between one brush holder and the brush carrier plate; the bugles comprise two spaced-apart front bugles and two spaced-apart rear bugles, the front bugles and the rear bugles being spaced apart one after another; each of the backing plates comprises two front first brush holder fixing holes and two rear front brush holder fixing holes; the second brush holder fixing holes comprise a front second brush holder fixing hole and a rear second brush holder fixing hole; each front bugle is bent after passing through one front first brush holder fixing hole and one front second brush holder fixing hole in turn, and each rear bugle is bent after passing through one rear first brush holder fixing hole and one rear second brush holder fixing hole in turn; and the bugles are bent to form a bent portion whose inner side is resisted against the brush carrier plate.

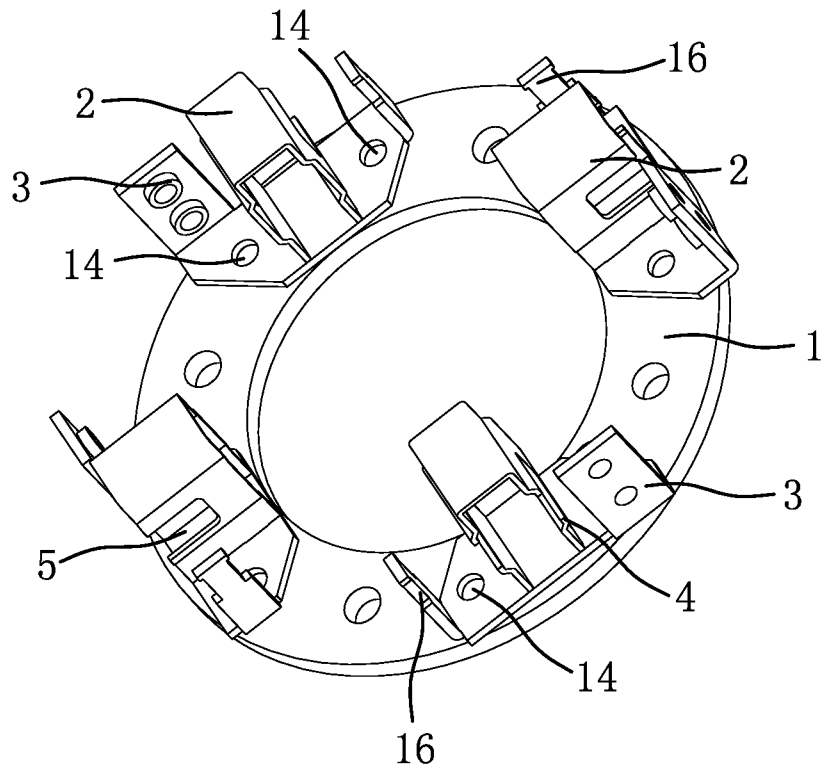

FIG. 1

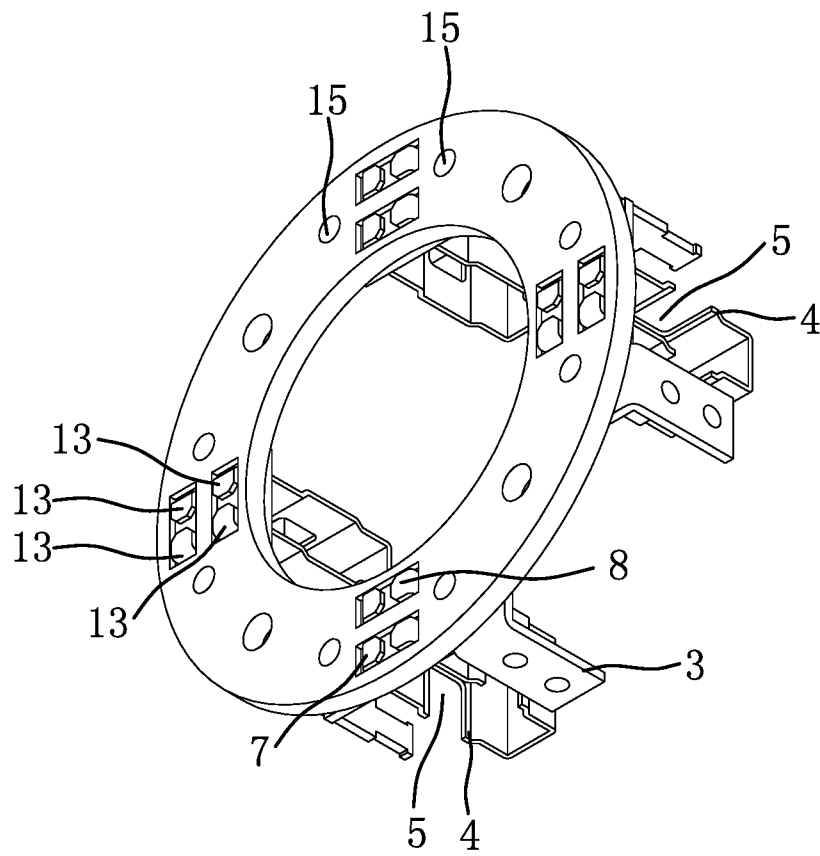

FIG. 2

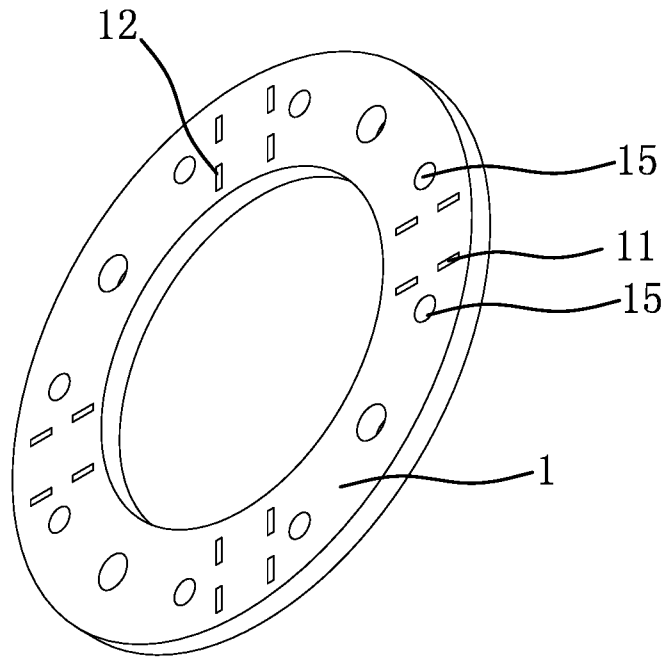

FIG. 3

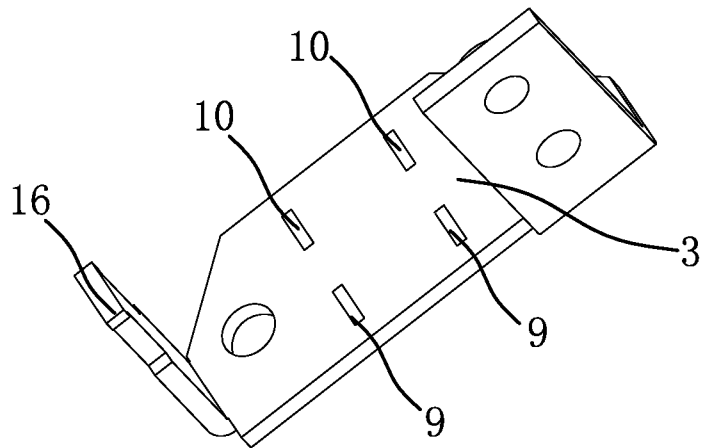

FIG. 4