



(72) WATSON, JOHN R., US
(72) HOLLFELDER, THOMAS A., US
(71) AMERITEC CORPORATION, US

(51) Int.Cl.⁷ H04Q 7/34

(30) 1997/09/02 (08/921,826) US

(54) **APPAREIL ET PROCÉDES DE TEST AUTOMATIQUE DE
SYSTEMES DE TELECOMMUNICATIONS SANS FIL**

(54) **APPARATUS AND METHODS FOR AUTOMATED TESTING OF
WIRELESS COMMUNICATIONS SYSTEMS**

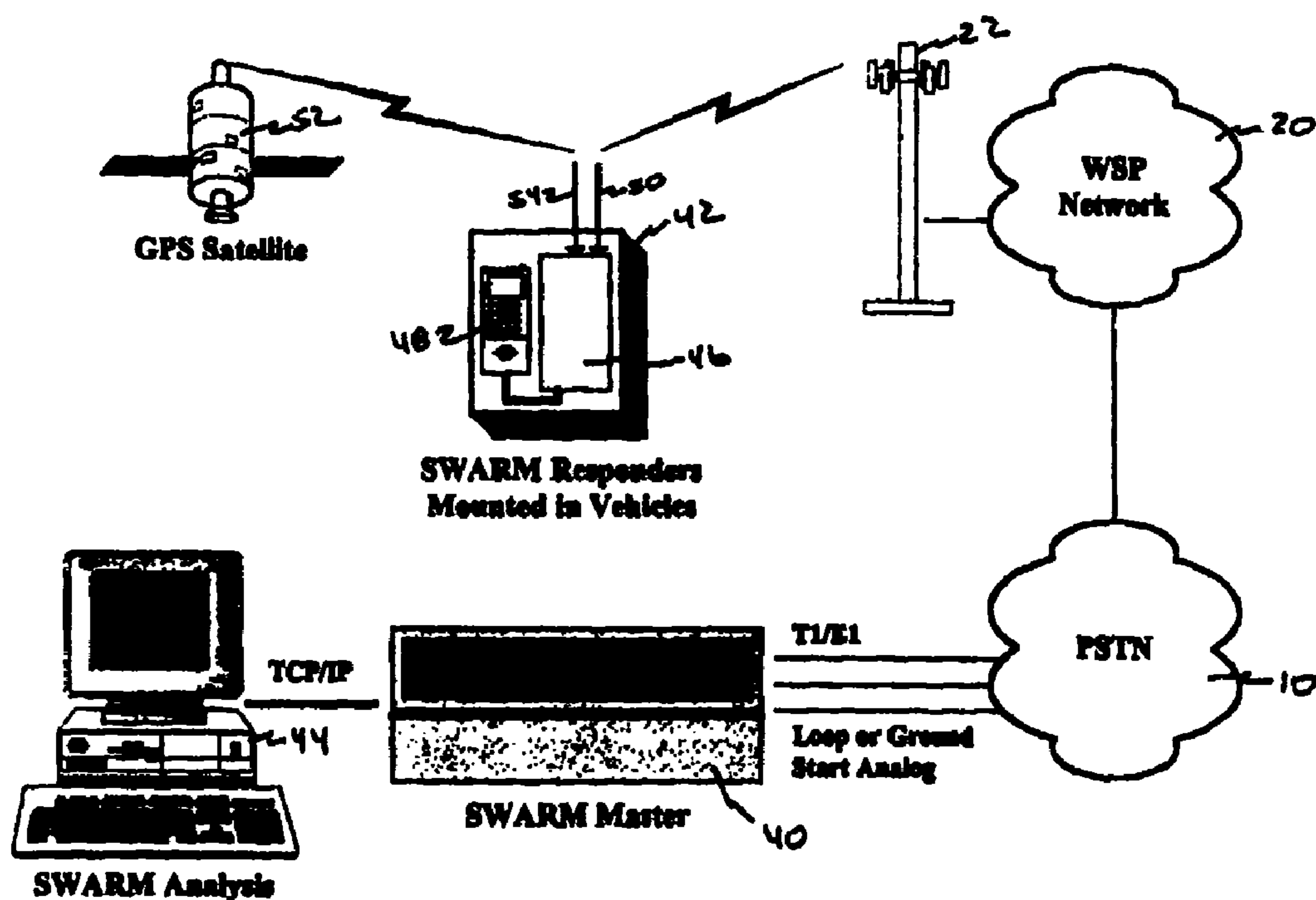

(57) L'invention concerne un appareil et des procédés de test d'un réseau fournisseur de services sans fil par un système d'abonné virtuel. Dans un aspect de cette invention, un procédé de tests d'un réseau fournisseur de services sans fil, d'une manière générale, comprend les étapes consistant à effectuer des tentatives d'appels vers l'extérieur sous la commande d'une unité maîtresse vers des répondeurs mobiles automatiques multiples, à

(57) Apparatus and methods are provided for testing a wireless service provider network through a virtual subscriber system. In one aspect of this invention, a method for testing a wireless service provider network generally comprises the steps of initiating outbound call attempts under control of a master to multiple automatic, mobile responders, receiving calls at at least some of the responders, monitoring parameters relating to the



recevoir les appels au niveau d'au moins certains des répondeurs, à contrôler des paramètres relatifs au réseau fournisseur de services sans fil et à transmettre des informations indicatives de ces paramètres à l'unité maîtresse. Les paramètres pouvant être testés par l'intermédiaire du système comprennent le test de la qualité audio, notamment le test de 23 tonalités, le test quantitatif de la qualité audio, le test de la puissance RF, le test de fréquence et le test d'analyse de spectre. Dans le procédé préféré, les tests peuvent être effectués par des unités de répondeur multiples déplacées à l'intérieur de la zone géographique du fournisseur de services sans fil, de manière à fournir une indication en temps réel de la qualité du réseau. De préférence, un système de positionnement global est utilisé pour produire des informations de localisation relatives à la position du répondeur. Dans un autre aspect de l'invention, on a prévu un procédé de test de communication entre deux dispositifs de télécommunications sans fil. Une unité maîtresse effectue un appel vers un premier répondeur comprenant un premier dispositif de télécommunication sans fil, le premier dispositif de télécommunication sans fil effectue un appel sur le réseau vers un second dispositif de télécommunication sans fil dans un second répondeur, le test est effectué et les résultats de ce test sont transmis à l'unité maîtresse par le réseau. Les dispositifs et les réseaux de télécommunications sans fil pouvant être testés avec ces inventions comprennent au moins des systèmes téléphoniques mobiles et des systèmes SCP.

wireless service provider network and transmitting information indicative of those parameters to the master. Parameters testable through the system include audio quality testing, including 23-tone testing, quantitative testing of audio quality, RF power testing, frequency testing and spectrum analysis testing. In the preferred method, testing may be performed by multiple responder units displaced throughout the geography of the wireless service provider, so as to provide real time indication of the network quality. Preferably, a global positioning system is utilized to provide location information regarding a responder's position. In yet another aspect of this invention, a method for testing communication between two wireless communication devices is provided. A master initiates a call to a first responder including a first wireless communication device, the first wireless communication device initiates a call over the network to a second wireless communication device in a second responder, testing is performed, and the results of the testing are provided to the master via the network. Wireless communication devices and networks testable with these inventions include at least mobile phone systems and PCS systems.



PCT

WORLD INTELLECTUAL PROPERTY ORGANIZATION
International Bureau

INTERNATIONAL APPLICATION PUBLISHED UNDER THE PATENT COOPERATION TREATY (PCT)

| | | |
|--|------------------|--|
| <p>(51) International Patent Classification 6 : H01Q</p> | <p>A2</p> | <p>(11) International Publication Number: WO 99/12228 (43) International Publication Date: 11 March 1999 (11.03.99)</p> |
| <p>(21) International Application Number: PCT/US98/16763 (22) International Filing Date: 21 August 1998 (21.08.98) (30) Priority Data: 08/921,826 2 September 1997 (02.09.97) US (71) Applicant: AMERITEC CORPORATION [US/US]; 760 Arrow Grand Circle, Covina, CA 91722 (US). (72) Inventors: WATSON, John, R.; 963 North Live Oak Avenue, Glendora, CA 91740 (US). HOLLFELDER, Thomas, A.; 20809 Mesa Rica Road, Covina, CA 91724 (US). (74) Agents: MURPHY, David, B. et al.; Lyon & Lyon LLP, Suite 4700, 633 West Fifth Street, Los Angeles, CA 90071-2066 (US).</p> | | <p>(81) Designated States: AU, BR, CA, CN, DK, JP, KR, MX, NO, European patent (AT, BE, CH, CY, DE, DK, ES, FI, FR, GB, GR, IE, IT, LU, MC, NL, PT, SE). Published <i>Without international search report and to be republished upon receipt of that report.</i></p> |

(54) Title: APPARATUS AND METHODS FOR AUTOMATED TESTING OF WIRELESS COMMUNICATIONS SYSTEMS

(57) Abstract

Apparatus and methods are provided for testing a wireless service provider network through a virtual subscriber system. In one aspect of this invention, a method for testing a wireless service provider network generally comprises the steps of initiating outbound call attempts under control of a master to multiple automatic, mobile responders, receiving calls at at least some of the responders, monitoring parameters relating to the wireless service provider network and transmitting information indicative of those parameters to the master. Parameters testable through the system include audio quality testing, including 23-tone testing, quantitative testing of audio quality, RF power testing, frequency testing and spectrum analysis testing. In the preferred method, testing may be performed by multiple responder units displaced throughout the geography of the wireless service provider, so as to provide real time indication of the network quality. Preferably, a global positioning system is utilized to provide location information regarding a responder's position. In yet another aspect of this invention, a method for testing communication between two wireless communication devices is provided. A master initiates a call to a first responder including a first wireless communication device, the first wireless communication device initiates a call over the network to a second wireless communication device in a second responder, testing is performed, and the results of the testing are provided to the master via the network. Wireless communication devices and networks testable with these inventions include at least mobile phone systems and PCS systems.

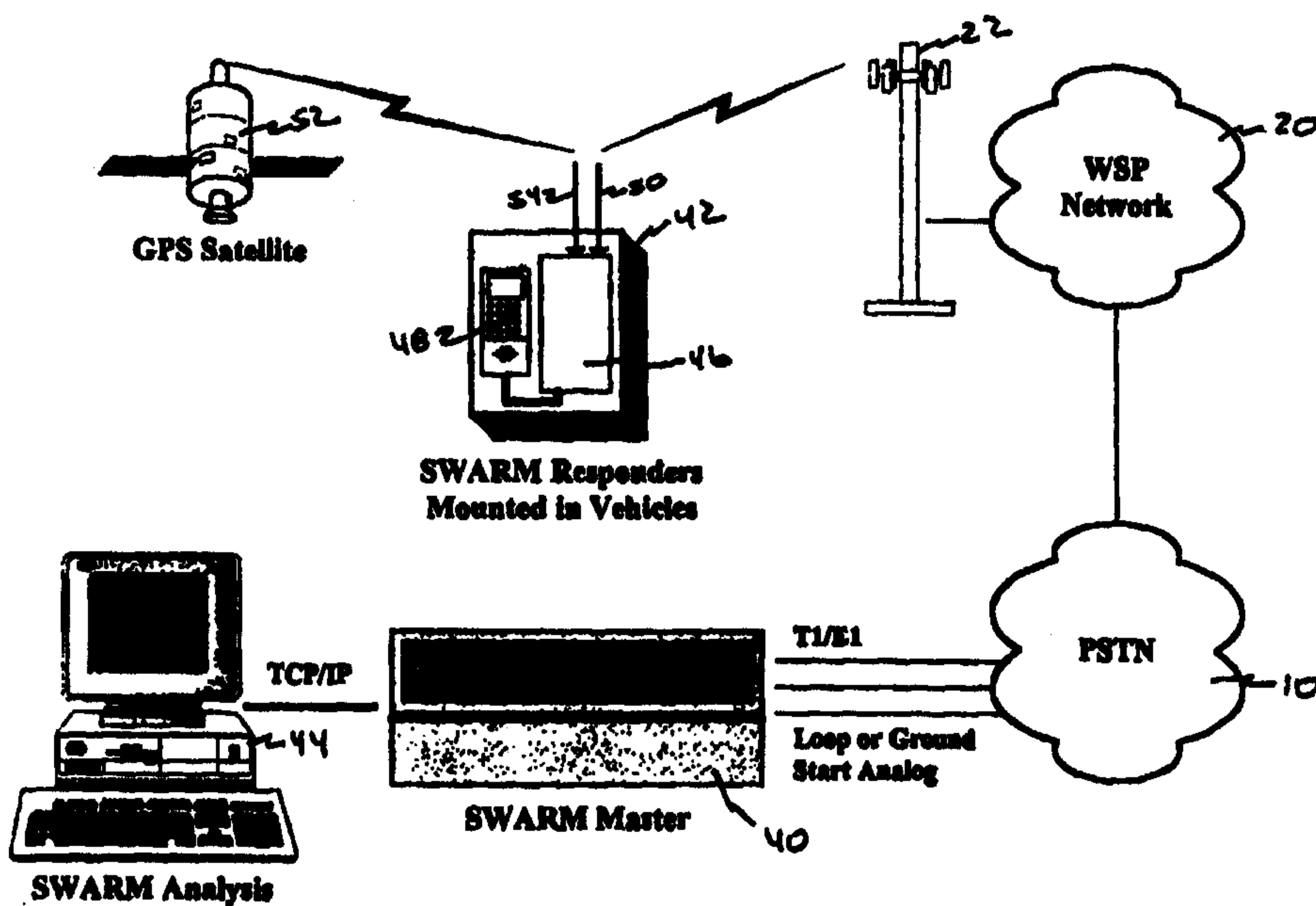

DESCRIPTION**APPARATUS AND METHODS FOR AUTOMATED
TESTING OF WIRELESS COMMUNICATIONS SYSTEMS**

5

Field of the Invention

This invention relates to the field of automated test equipment. More particularly, it relates to automated test equipment for wireless communication systems, especially cellular communications systems and personal communications systems.

10Background of the Invention

Various wireless communication systems have been known in the art. Personal wireless communication systems are available in various forms and formats. Currently, cellular telephone systems are a popular form of wireless personal communication systems. Additionally, personal communication services (PCS) systems are now available.

15

Fig. 1 shows a diagrammatic view of a typical wireless service provider network. Broadly, the complete system includes the public switched telephone network 10, the wireless service provider network 20 and wireless subscriber users 30. The public switched network 10 serves in a conventional manner to provide switched communications among various callers. The wireless service provider network 20 generally comprises a distribution network, most typically including a radio frequency distribution network of cell sites 22. The cell sites 22 provide a wireless communication link to mobile communication devices or mobile phones 32. Mobile phones 32 are known by various terms, and come in various technologies, examples of such terminology and technology include, but are not limited to, wireless cellular, flip phones, cellular phones, mobile telephones, cell phones and PCS phones. Generally, within the wireless service provider network 20, one or more cell sites 22 are linked to a base station controller 24. In turn, one or more base station controllers 24 are linked to a mobile telephone switching center 26. The communication link 12 between the public switch network 10 and the wireless service provider 20, as well as communication links 28 among the various components of the wireless service provider network 20, are typically digital land-

20
25
30

based or microwave carrier systems. For example, T1, T3 or SONET facilities may be utilized.

The particular system architecture within a given wireless service provider network currently tend to be manufacturer specific. Current manufacturers of such systems include Motorola, LM Ericsson, Nortel, Hughes Network Systems, Astronet and Lucent Technologies. Mobile phones are available from many commercial sources.

Historically, mobile phones were analog systems. More recently, mobile phones include dual-mode mobile phones which support both analog and digital transmission systems. In addition to the providers of the wireless service network equipment, identified previously, current mobile phone manufacturers also include Oki, Samsung, Toshiba and NEC.

Cell sites are geographically distributed throughout a region served by a given wireless service provider. As the cell site has a limited geographic coverage area, wireless service providers have been required to determine service area coverage through various methods. Predictive models of coverage area have been utilized. Further, "drive tests" have been utilized in which a technician affiliated with the wireless service provider moves about the geography of the region covered by the wireless service provider. Typically, a skilled field engineer drives a vehicle including sophisticated test equipment throughout the region believed to be covered by the wireless service provider. Commonly, the testing is initiated by causing a call to be placed from the mobile test equipment to a land-based, receiving location. A communication path is thereby established between the mobile test equipment and the receiving station. The initiation of the call from the mobile test equipment is initiated by the technician. Tests typically performed include detailed radio frequency and system performance test data measuring radio frequency strength, frequency, noise, co-channel interference as well as other relevant parameters. Usually, the test data is collected and archived within the mobile test vehicle. The test data collected by the mobile unit is then often times combined with data from multiple other mobile units upon their return to the land-based facility.

Such "drive tests" utilizing dedicated testing vehicles is subject to a number of disadvantages. First, the testing for the entire wireless service provider network is not made in real time, as the test data resides in multiple vehicles, not at a central site. Second, the costs

associated with such dedicated vehicles is very high. A fully equipped vehicle used in a drive test often costs from \$100,000 to \$250,000. Further, a skilled field engineer is required to operate the equipment and conduct the tests. Generally, multiple tasks must be performed in operating such systems, for example, the field engineer often collects the data, whereas then
5 that data must be entered by yet another person for processing, and later for display. Yet further intervention is required for modifications or upgrading of the equipment such as for upgrading software through revisions, bug-fixes or feature additions.

Yet another type of testing performed on wireless service provider networks are cell simulation. The term call simulator has many synonyms, including, but not limited to, load
10 tester, load box, line simulator and bulk call generator. All of these terms generally relate to devices which serve to simulate calls. Typically, a call simulator serves to automatically generate outbound calls through the wireless service provider network to various intended called parties. Typically, the called parties are individuals having a mobile phone. Various information regarding the placement of calls, such as number of attempts and call completion
15 percentages, may be generated at the load box end of the system. Typically, the called parties may be requested to manually record various data regarding the call, such as location of the received call and some subjective assessment of the call quality.

Test equipment has been utilized in which a dedicated phone testing unit is placed in a vehicle. The unit is adapted to work with a specific manufacturer's phone. Calls may be
20 placed from and received by the dedicated phone, with network parameters under test including network coverage, quality, and identification of location of existing problems. A GPS capability is provided to provide location information. The parameter information is stored to a PCMCIA flash disk. This data may be transferred by a technician after storage for collection and analysis by the system.

In yet another system, a ruggedized personal computer is placed in a mobile vehicle
25 for wireless network provider testing. The system utilizes actual speech samples to monitor the system quantitatively utilizing a mean opinion scoring measurement. The mobile test unit consists of an embedded PC, audioprocessing hardware, GPS receiver and one or more cellular transceivers. The mobile test unit automatically places and receives calls to and from
30 the field test unit while being driven over a selected or random route.

Wireless service providers have long sought methods for conducting coverage tests

which provide usable system quality and performance data without the requirement for such time intensive and costly field engineer drive tests, and to make audio quality tests using traditional test methods without the need to depend on subjective Mean Opinion Score quality rating measurements. This invention is directed towards a solution of these long standing
5 concerns.

Summary of the Invention

Apparatus and methods for automated testing of wireless communications systems is provided. In one aspect of the inventive method, testing of the wireless service provider
10 network generally comprises the steps of, first, initiating one or more outbound call attempts under control of a master to one or more automatic mobile responders, second, receiving calls from at least some of the automatic, mobile responders, third, monitoring parameters relating to the wireless service provider network and fourth, transmitting information between the responder and master indicative of the parameters. Testing of the wireless service provider
15 may be in any form or parameter, and especially includes quantitative testing of the wireless service provider network. Other parametric testing optionally includes radio frequency power level testing, frequency testing, audio quality testing, especially through the use of the 23-tone test, and spectrum analysis. Optionally, the testing method further includes the step of analyzing the information transmitted, preferably from multiple responders to the master. In
20 this way, information may be obtained from multiple automatic mobile responders located throughout the geography covered by the wireless service provider network, thereby providing real-time assessment of the network.

The system level invention comprises a system for testing a wireless network which generally comprises an analysis system coupled to a master, where the master serves to
25 automatically place calls, and optionally to receive calls, when connected to a wireless network or public switched network. The system includes one or more responders adapted to automatically communicate through the wireless service provider network with the master.

The responders are provided with an antenna connection for communication with the wireless service provider RF (radio frequency) network and include a receptacle adapted to receive one
30 or more wireless communication device. In accordance with one aspect of this invention, one or more standard mobile phones of any manufacturer may be utilized to emulate regular

wireless subscriber calls. The mobile phones used in the responder architecture may alternatively be VLSI-chip-level mobile phones, test phone or any combination thereof. A responder control system typically includes a wireless control device controller, parametric testing systems and digital signal processing capability. Preferably, the system is equipped
5 with a global positioning system which provides some or all of the position, time and velocity of the responder unit.

In yet another aspect of this invention, apparatus and method are provided for testing communications between a first wireless communication device and a second wireless communication device over a wireless service provider network. Generally, the apparatus and
10 steps comprise utilizing a master to initiate a call to a first responder including a first wireless communication device, wherein the first responder is instructed to effectuate a subsequent call to the second wireless communication device in the second responder. Once the call is placed between the first wireless communication device and second wireless communication device, testing is performed. At least one of the first and second responders communicates with the
15 master to provide test data regarding the call between the first wireless communication device and the second wireless communication device.

In one aspect of this invention, a testing system is provided whereby "virtual subscribers" are provided by automated, mobile responder units. In the preferred embodiment, the responders are of sufficiently small size so as to readily fit within a typical
20 automobile trunk, and are more particularly preferred to be substantially smaller than the volume of the trunk, preferably less than one cubic foot. In this way, the responders may be placed in vehicles which are not dedicated to the testing function, but have a independent purpose. For example, responders may be included in vehicles that cover regular, thorough routes, such as postal or public transit vehicles, or in vehicles which cover relatively regular
25 routes with some degree of variation, such as delivery vehicles, or in vehicles which cover random routes, and may go into and out of the service area, such as taxis, or vehicles owned by the wireless service provider. While the responders typically would be located within a mobile vehicle, at least certain of the responders within a system may be immobile without varying from the invention described herein.

30 In yet another aspect of this invention, the system may be utilized to emulate any feature or function of the wireless service provider and to test implementation of that feature.

By way of example, certain systems permit a mobile telephone number to be changed to another area code. Certain models permit mobile phones telephone numbers to be changed remotely. The system of this invention would permit the changing of the telephone number of the mobile phone, when permitted, either locally at the responder or remotely, to permit
5 testing of this feature. In this way, accuracy of roaming and number verification systems can be achieved. This particular test would serve to verify the home location register (HLR) used by wireless service providers. Yet other features of such a test system would permit testing of an authentication system center (AUC) which manages the security data for subscriber authentication. Similarly, the equipment identify register (EIR) which stores the data of
10 mobile equipment (ME) or ME-related data.

Accordingly, it is an object of this invention to provide an improved apparatus and method for providing usable system quality and performance data.

It is yet another object of this invention to provide an apparatus and system which provides information regarding a wireless network without requiring drive tests by skilled
15 field engineers.

It is yet a further object of this invention to provide a system which serves to improve the quality and reliability of wireless communications systems.

Brief Description of the Drawings

20 Fig. 1 shows a diagrammatic view of a wireless service provider network.

Fig. 2 shows a diagrammatic view of the subscriber wireless automated remote measurement system.

Fig. 3 shows a block diagram description of the analysis software components for the subscriber wireless automated remote measurement system.

25 Fig. 4 shows a perspective view of the responder equipment.

Fig. 5 shows a block diagram view of the main hardware components of the responder system.

Fig. 6 shows a flowchart for the responder program flow.

Fig. 7 shows a flowchart for the inside weight for command sequence.

30 Fig. 8 shows a flowchart for the received call-back instructions sequence.

Fig. 9 shows a flowchart for a send-current location/time sequence.

Fig. 10 shows a flowchart for the send oldest unsent unsuccessful call details sequence.

Fig. 11 shows a flowchart for the 23-tone test receiving and scoring sequence.

Fig. 12 shows a flowchart for a network access test.

5 Fig. 13 shows a flowchart for an audio quality test.

Fig. 14 shows a flowchart for an unsuccessful completion test.

Fig. 15 shows a flowchart for a dropped call test.

Detailed Description of the Invention

10 Fig. 2 shows a diagrammatic view of primary elements of the subscriber wireless automated remote measuring system in one aspect of this invention. A call simulator 40 serves to initiate telephone calls. Preferably, the call simulator 40 emulates telephone calls placed over lines 56 through the public switched telephone network 10 and the wireless service provider network 20 to a responder 42 via the cell site 22. The call simulator 40
15 preferably includes the ability to receive calls originated from the responder 42. Call simulators are available from many commercial sources including Ameritec Corporation (FeatureCall™ system), Zarak Systems, Inc. (Abacus: Advanced Bulk Call Simulator), Teradyne (Hammer product line), and Redcom (TeleTraffic Generator).

The responder 42 serves to generate and/or receive calls. Further, it preferably
20 performs parametric measurements of test calls and network status over the wireless network through one or more cellular telephone interfaces. The responder typically would include one or more wireless communication device 48, such as a mobile phone or PCS device.

In the preferred embodiment of the subscriber wireless automated remote measuring
25 system, the responder 42 is capable of providing geographic position information. Most preferably, the responder 42 provides geographic position information through use of the global positioning system. In such a global positioning system, a satellite 52 provides positional information to the responder 42 as received by antenna 54. The responder 42 preferably provides the positional information via antenna 50 during a telephonic
30 communication between the responder 42 and the line simulator 40 and analyzer 44.

In operation, the responder 42 may be deployed to various geographic locations.

In the preferred mode, the responder 42 would be included within a vehicle so as to travel through the service area. Automated coverage testing may be achieved through the use of such mobile responder units. In the preferred embodiment, the responder units 42 operate remotely under control of the master 40. Most preferably, numerous responders 42 are provided in separate vehicles or locations throughout the service area, preferably in separate vehicles, so as to provide data to the master 40 and analyzer 44 under remote control from the master 40.

In one main intended application, this test methodology and equipment enables the wireless service provider the ability to validate service area predictive model data and to provide a survey of the quality of service and network status throughout a designated service area utilizing the wireless service providers subscriber's mobile phones. While the system may be utilized to test for any telephony related problem consistent with the goals and objects of this invention, the main types of problems contemplated are as follows. First, unsuccessful network access may be monitored. Such an unsuccessful network access is an uplink problem wherein the wireless subscriber is unable to originate calls from a mobile phone. Secondly, the system may check for audio quality. Typically, simulation of voice conversation is performed over a wireless connection and measured from the wireless subscribers location. Both downlink call simulation and uplink call simulation may be tested. Third, unsuccessful call completion may be monitored. An unsuccessful call is defined as any call, either uplink and/or downlink, not completed as dialed. Fourth, dropped calls may be monitored. This generally is defined as any call terminated before a call termination command is initiated by either the calling or called party. Generally, the responder 42 is preferably located within a vehicle, most preferably a vehicle which moves through a relatively large geographic area within the wireless service provider region. Examples of vehicles preferably utilized with the methods of the system include: postal or public transit vehicles (such as those that cover regular, thorough routes), delivery vehicles (such as those that cover regular routes which vary somewhat), taxis or other wireless service provider vehicles (such as those which cover random routes and sometimes go into and out of the service area). Alternatively, the responder 42 may be placed at a fixed location.

Fig. 3 shows a flowchart for the subscriber wireless automated remote measurement

system analysis methods. The master 60 bi-directionally interfaces with a graphical user interface system 62, such as the FeatureCall™ system. The master 60 accesses the test processor 64. The test processor 64 in turn interacts with the database 66. The database 66 bi-directionally accesses a configuration screen and data manager 68 various reports 70, standard and custom, may be prepared. Generally, the subscriber wireless automated remote measuring system analysis consists of the test processor 64, database 66, configuration screen and data manager 68 and report generator 70.

The database 66 must be of sufficient capacity, speed and sophistication to achieve the goals and objectives of this invention. Generally, a relational database management system (RDBMS) is utilized. In the preferred embodiment, the database 66 is Oracle Work Group for Windows NT. Among its various functions, the database 66 serves as a repository for test results and preferably contains configuration information. The test processor 64, among other tasks, receives messages from the master 60 and translates them into SQL for the oracle database. Preferably, the test processor 64 is able to connect to multiple masters 60. Optionally, feedback may be provided from the test processor 64 to the master 60. The report package 70 preferably includes a graphical user interface (GUI) application to display test results and print reports. Derived values, e.g., signal to noise ratio, may be calculated by the report package 70. The configuration screens and data manager package 68 preferably serves to save data captured by the system for future analysis. Generally, system 68 is a file management system for augmentation of the database 66. Optionally, the system 68 may be incorporated into the report package 70.

Optionally, a geological information system for GIS may be utilized in conjunction with the system disclosed herein. Typically, a geological information system provides through mapping software a system in which previously compiled geographic data may be combined with newly collected and/or processed information to provide a composite image. Such software is available from many sources, including ESRI (Environmental Systems Research Institute, Inc.), who offer programs including, but not limited to, ArcView, MapObjects, and ARC/INFO. Overlays may be utilized on the underlying data, such as location of cell sites, commercially existing map grids (e.g., Thomas Brother map grids) or other relevant points of interest, either geographical or man-made.

The analysis components identified in Fig. 3 may be run on a single Windows NT

workstation or notebook, or any other system which is compatible with the objects of this invention, such as Unix platforms, whether in a single work station or client-server configuration. Utilizing current technology, the system requirements would include: a single Pentium or PentiumPro processor running at or above 133 MHZ, 1.5 Gb available disk space, 48 Mb of RAM, a CD-ROM, 10 base-T network card, and Windows NT 3.51 SPx or Windows NT 4.0 SPx.

Fig. 4 shows an exploded, perspective view of the responder 80 in one physical implementation. Overall, the responder 80 may be relatively compact, such as to fit within a standard vehicle trunk, and is most preferably relatively compact, in the preferred embodiment being 8 inches x 11 inches x 2.5 inches, or smaller. A base 82 is connected to a lid 84 such as by operation of a key lock system 88 which cooperatively secures the lid 84, base 82 and bracket 86. Preferably, the lid 84 is locked to the base 82 via a lock assembly 88. The bracket 86 preferably includes flanges 90 disposed on the bottom of the base to permit mounting of the responder 80, such as on the floor of a vehicle trunk. Optionally, a bracket may be utilized to facilitate vehicle trunk or side-wall installations.

The interior of the responder 80 is preferably divided into two major components, the components being divided by a shield 92 so as to form a first compartment 94 and a second compartment 96. The first compartment 94 may contain, preferably, one or more mobile phones 48, and may be alternatively designated as the mobile phone compartment 94. The second compartment 96 may contain responder electronics and be alternatively designated as the responder electronics compartment 96. One or more printed circuit boards 98 may be supported from the base 82 via standoffs 100. The printed circuit boards 98 may include the circuitry for the responder and, optionally, the global positioning satellite daughter board standoffs.

In yet another aspect of this invention, the combination of a standard subscriber mobile phone and a component or chip-level mobile phone may be utilized on-line simultaneously on two separate cellular or PCS calls. The results of these two separate calls may be coordinated and correlated by the analysis system.

The first compartment 94, when adapted for holding the mobile phone, preferably includes foam rubber material on both the base 82 and the lid 84. This foam rubber

material serves to receive the mobile phone 48 within a nest so as to support the mobile phone 48 during vehicle motion. Optionally, a mobile phone window 102 is provided in the lid 84 to permit user observation of the mobile phone 48 panel.

The second compartment 96 is connected to the first compartment 94 by a connector 104 passing through shield 92. The mobile phone connector 106 meets with connector 104 and connects to the mobile phone 48. The mobile phone connector 106 is typically unique depending upon the type of mobile phone 48 utilized. The software utilized by the responders cellular telephone controller serves to configure the system for the specific brand of mobile telephone then utilized within the responder 80.

The responder 80 includes various connections to external. An antenna connection 108 and global positioning satellite antenna connector 110 are provided. A barrier strip 112 or water tight connector preferably provides for connection to ground 114, battery 116 and vehicle ignition 118. Preferably, provision is made to reduce risk of electrical error from electrostatic discharge through use of O-rings or elastomeric gaskets for sealing.

Fig. 5 shows an electrical block diagram of the responder electronics. A microprocessor 110, such as Zilog microprocessor, is coupled to an address bus 112, databus 114 and control signal lines 116. A power supply 118 provides power to the system, and preferably comprises the vehicle battery. A regulator/sensor 120 provides a low battery voltage flag signal to the microprocessor 110 via the address but 112. The regulator 120 optionally couples to a mobile phone variable voltage regulator 122, which in turn is connected to the mobile phone input/output port 124. The mobile phone input/output port 124 is preferably coupled to an analog to digital codec 126 providing phone/audio input/output. The A/D codec 126 is coupled to buses, such as address bus 112 and databus 114. Preferably, the A/D codec 126 is coupled to a digital signal processing chip 128, such as a 2171 DSP chip. The mobile phone input/output port 124 is further connected for mobile phone data and control signal communication to the mobile phone controller 130. The mobile telephone 130 is coupled to the buses, such as the address bus 112 and databus 114. External computer input/output 132 is likewise coupled to the buses.

Various control signals 134 are provided to various electronics. Chip select is effected via coupling between the address bus 112 and the control signal interface 134. Optionally, an electronically programmable logic device (EPLD) 136 connects the chip

select and control signal interface 134.

Optionally, a global positioning satellite system is utilized. A GPS daughter board 136 is coupled to the database 114. An antenna 138 connects to the daughter board 136.

5 Fig. 6 is a software flowchart for the responder program flow. At start-up 140, cold start begins when the power rises above 11.4 volts in a nominally 12 volt system. Initialization 142 includes some or all of the following: global reset, start z-180 program, initialize digital signal processor and mobile telephone controller (CTC) initialize mobile phone, set call-back count to 0 and set call sequence number to 0. At "phone on" decision
10 block 144, if the phone is not on, decision block 146 waits until the phone is turned on manually. If the phone is on, the call-back count block 148 is checked for count equals zero. If the count does not equal zero, then a call is placed to the master 150, which if not successful, block 158, is logged in the circular queue 160. A recheck is then made of the call-back count equally zero 148. If the call-back count is zero in decision block 148, the
15 system waits for a call at block 162, receives the call at block 164, and performs a command at block 166. When completed, the system hangs up at step 168.

Fig. 7 is a flowchart for the inside wait for command program flow. After initiation at the wait for command block 170, the sequence checks the vehicle power status 172 after which the "phone off-hook" decision block 174 is reached. If the phone is off hook at
20 block 174, the hang up mobile phone block 176 is executed and a return 178 is made to the wait for command block 170. If the phone is not off hook as determined in decision block 174, decision block 182 queries whether valid DTMF command has been received at block 180. If valid DTMF commands have been received at decision block 180, various commands may be directed, including one or more of the following: receive call back
25 instructions 182, send current location and/or time 184, send oldest unsent unsuccessful call details 186, and receive and score 23-tone test 188. If no valid DTMF are received at block 180, the program flows into block 172. In an alternative implementation, rather than utilizing DTMF tones for communication, a modem may be utilized. Whether transmitted via DTMF or modem, it is preferred that an error checking procedure be utilized with the
30 data transmission.

Fig. 8 shows a flowchart for the receive call back instructions sequence. The master

(e.g., master 40 in Fig. 2 or 60 in Fig. 3) establishes the call 190 to the responder (e.g., 42 in Fig. 2) and transmits a prompting command and parameters at block 192 after which the master proceeds to the done with command block 194. The responder initially is in the wait for command state 196. During the transmit command "11" and parameters state 192, the responder is in a corresponding receive command "11" and parameters state 198. After receipt of the command and parameters, the call back number and call back counts are saved at block 200. The responder then returns to the wait for command state 196.

Fig. 9 shows the flowchart for the send current location/time sequence. The master begins with the established call block 210. The system then transmits command "12" 212 to the responder. The responder begins in a wait for command state 214. After the transmit a prompting command step 212, the responder receives the prompting command in block 216. While the master is in the wait for reply state 218, the responder composes the result in state 220 and sends the result in state 222 to the master where it receives the result in state 224. After sending the result, the responder returns to the wait for command state 214. After the master receives the result in step 224, it sends the result to the test processor in block 226 after which the program is placed in a done with command state 228.

Fig. 10 shows a flowchart for the send oldest unsend unsuccessful call details program flow. The master begins with the establish call block 230. The master then transmits a prompting command at block 232 to the responder, which initially in the wait for command state 234 and then receives the prompting command in state 236. While the master is in a wait for reply state 238, the responder finds the data in the circular queue state 240, and sends the result at block 242 to the master who receives the result at block 244. The master then sends the result to the test processor at step 246, after which the master is done with the command at block 248.

Fig. 11 is a flowchart for the 23-tone test receiving and scoring sequence. The 23-tone test is described in one or more of the following United States Patents No. 4,301,536, 4,417,337 and 4,768,203, incorporated herein by reference. The master establishes the call at block 250, acquires digital signal processing (DSP) resource at block 252 and transmits a prompting command at block 254 to the responder. The responder begins in a wait state 256, and receives the command from state 254 at the responder side in state 258. While the

master waits a period of time, e.g., 500 milliseconds at block 260, the responder during that wait interval 260 prepares a DSP to receive the 23-tone sequence at block 262. The master sends the tones at step 264 and the receiver receives the tones at step 266. Alternatively, or in combination, the responder may be commanded to transmit the 23-tone test to the master for analysis of the uplink path audio quality. The responder then processes bins and prepares results at step 268, sending the result at step 270 to the master which receives them at step 272. The responder then proceeds to a wait for command state 256. Upon receipt of results of step 272, the master sends the results to the test processor at step 274 after which it is placed in a done with command state 276.

Fig. 12 shows a flowchart for the network access test. After start block 280, a call is placed to the mobile phone at step 282 after which call back instructions are sent at step 284. The system then hangs up and waits for a call at step 286, and is optionally subject to a time out 288. If the call is placed, the call is then accepted at step 290, where upon a request for the current location is made at step 292. A request for the oldest unsent unsuccessful call details step 294 is made. At decision block 296, if the system has not received all unsent data, the system loops to yet again request the oldest unsent unsuccessful call detail step 294. If all unsent data has been received as determined at decision block 296, decision block 298 determines whether more call attempts are necessary. If not, the program flows to a done state 300, whereas if more call attempts are required the program flows to the hang up and wait for call state 286.

Fig. 13 shows a flowchart for an audio quality test. From start block 310, a call is placed to the mobile phone at step 312, upon which a request is made for the current location in step 314 as determined by the responder. Thereafter, a 23-tone test is conducted at step 316. Alternatively, or in combination, the responder may be commanded to transmit the 23-tone test to the master for analysis of the uplink path audio quality. Decision block 318 determines if the loop is done. If the loop is not done, another call to the mobile phone at step 312 is made. If the loop 318 is done, the system hangs up at step 320, and is placed in a done state 322. With regard to tone tests, such as the 23-tone test, the system may be full duplex, half duplex or simplex.

30

Fig. 14 shows a flowchart for an unsuccessful completion test. From start block

330, a call is placed to the mobile phone at step 332. After a request for the current location in step 334, the results are logged in the master at step 336. Thereafter, the system hangs up at step 338. As determined by decision block 340, if the loop is not done, the system loops back to the call mobile phone step 332, whereas if the loop 340 is done the system goes to a done state 342.

Fig. 15 shows a flowchart for a dropped call test. From the start block 350, a call is placed to the mobile phone in step 352. The results are logged in the master at step 354. Thereafter, for a predetermined period of time the system waits while tracking the current location and time at step 356. At decision block 358, if the call is still up, the system hangs up at step 360 and logs a successful call to the test processor at step 362. If the call is not still up at decision block 358, it is logged as a dropped call to the test processor at step 364. At the loop done decision block 366, if the loop is not done, a call mobile phone step 352 is executed. If the loop done 366 is completed, the system goes to a done state 368.

Although the foregoing invention has been described in some detail by way of illustration and example for purposes of clarity and understanding, it may be readily apparent to those of ordinary skill in the art in light of the teachings of this invention that certain changes and modifications may be made thereto without departing from the spirit or scope of the appended claims.

We Claim:

1. A method for testing a wireless service provider network comprising the steps of:

5 initiating one or more outbound call attempts under control of a master to one or more automatic, mobile responders,

receiving calls at at least some of the automatic, mobile responders,

10 monitoring parameters of the network during the call between the master and the automatic, mobile responder, and

transmitting information indicative of the parameters to the master.

2. The method of claim 1 for testing a wireless service provider network wherein the parameter tested includes quantitative and qualitative testing.

3. The method of claim 1 for testing a wireless service provider network wherein the testing includes audio quality testing.

4. The method of claim 3 for testing a wireless service provider network wherein the audio quality testing includes a 23-tone test.

20 5. The method of claim 4 for testing a wireless service provider network wherein the 23-tone test is in half duplex.

6. The method of claim 4 for testing a wireless service provider network wherein the 23-tone test is full duplex.

25 7. The method of claim 4 for testing a wireless service provider network wherein the 23-tone test is simplex.

8. The method of claim 1 for testing a wireless service provider network wherein the testing includes monitoring the radio frequency power.

9. The method of claim 1 for testing a wireless service provider network wherein the testing includes monitoring frequency.

10. The method of claim 1 for testing a wireless service provider network wherein
5 the testing includes spectrum analysis.

11. The method of claim 1 for testing a wireless service provider network further including collection and transmission of information regarding global positioning.

10 12. The method of claim 11 for testing a wireless service provider network wherein the global positioning information includes position.

13. The method of claim 11 for testing a wireless service provider network wherein the global positioning information includes the time as provided by the global
15 positioning system.

14. The method of claim 11 for testing a wireless service provider network wherein the velocity of the mobile responder is determined.

20 15. The method of claim 1 for testing a wireless service provider network wherein the transmission of information indicative of the parameters is performed in a call initiated by the master to the responder.

16. The method of claim 1 for testing a wireless service provider network wherein
25 the step of transmitting information indicative of the parameters is performed in a call initiated by the responder to the master.

17. The method of claim 1 for testing a wireless service provider network further including the step of analyzing the information transmitted to the master.

30

18. The method of claim 1 for testing a wireless service provider further including

the step of displaying the information provided from the responders to the master.

19. The method of claim 1 for testing a wireless service provider network further including the step of archiving data supplied to the master in real time.

5

20. The method of claim 1 for testing a wireless service provider network further including the step of displaying information regarding the network in real time.

10

21. The method of claim 1 for testing a wireless service provider network further including the step of displaying geological information systems data in real time.

22. The method of claim 1 for testing a wireless service provider network further including the step of collecting data regarding calls not received.

15

23. A method for testing communication between a first wireless communication device and a second wireless communication device over a wireless service provider network, comprising the steps of:

first, initiating a call from a master to a first responder including the first wireless communication device,

20

second, initiating a call from the first wireless communication device to the second wireless communication device in a second responder over the wireless service provider network,

monitoring parameters of the call, and

25

communicating to the master information regarding the call between the first wireless communication device and the second wireless communication device.

24. The method of claim 23 for testing communication between wireless communication devices wherein at least one of the first and second wireless communication devices is a mobile phone.

30

25. The method of claim 23 for testing communication between wireless

communication devices wherein at least one of the first and second wireless communication devices is a personal communications systems device.

26. A system for testing a wireless communication network comprising:

5 a master for automatically initiating calls, adapted for connection to a switched network including a wireless service provider network,

one or more wireless responders adapted to automatically communicate with the master via the switched network, and

10 an analysis system for receiving information from the responders through the wireless network in real time for providing test results regarding the wireless network.

27. The system of claim 26 for testing a wireless network wherein the analysis system includes a test processor.

15 28. The system of claim 26 for testing a wireless network wherein the analysis system includes a database for archiving test information.

29. The system of claim 26 for testing a wireless network wherein the analysis system includes a graphical user interface.

20

30. The system of claim 26 for testing a wireless network wherein the public switch network further includes the public switched telephone network.

25 31. A mobile responder for testing a wireless service provider network between a base station including a master and a wireless communication device located at the mobile responder, comprising:

an antenna connection adapted for communication with the wireless service provider network,

30 a wireless communication device receptacle adapted to receive a wireless communication device,

a responder control system including,

20

a wireless communication device controller,
a parametric test system, and
a test result provision system adapted to provide test results to the
master, and
5 a power connection for providing power to the responder control
system.

32. The mobile responder of claim 31 for testing a wireless service provider
network wherein the responder includes two or more separate compartments.

10

33. The mobile responder of claim 32 wherein a first compartment is adapted to
receive the wireless communication device.

34. The mobile responder of claim 32 wherein a second compartment includes the
15 responder control system.

35. The mobile responder of claim 32 further including a pass through connection
between the compartments.

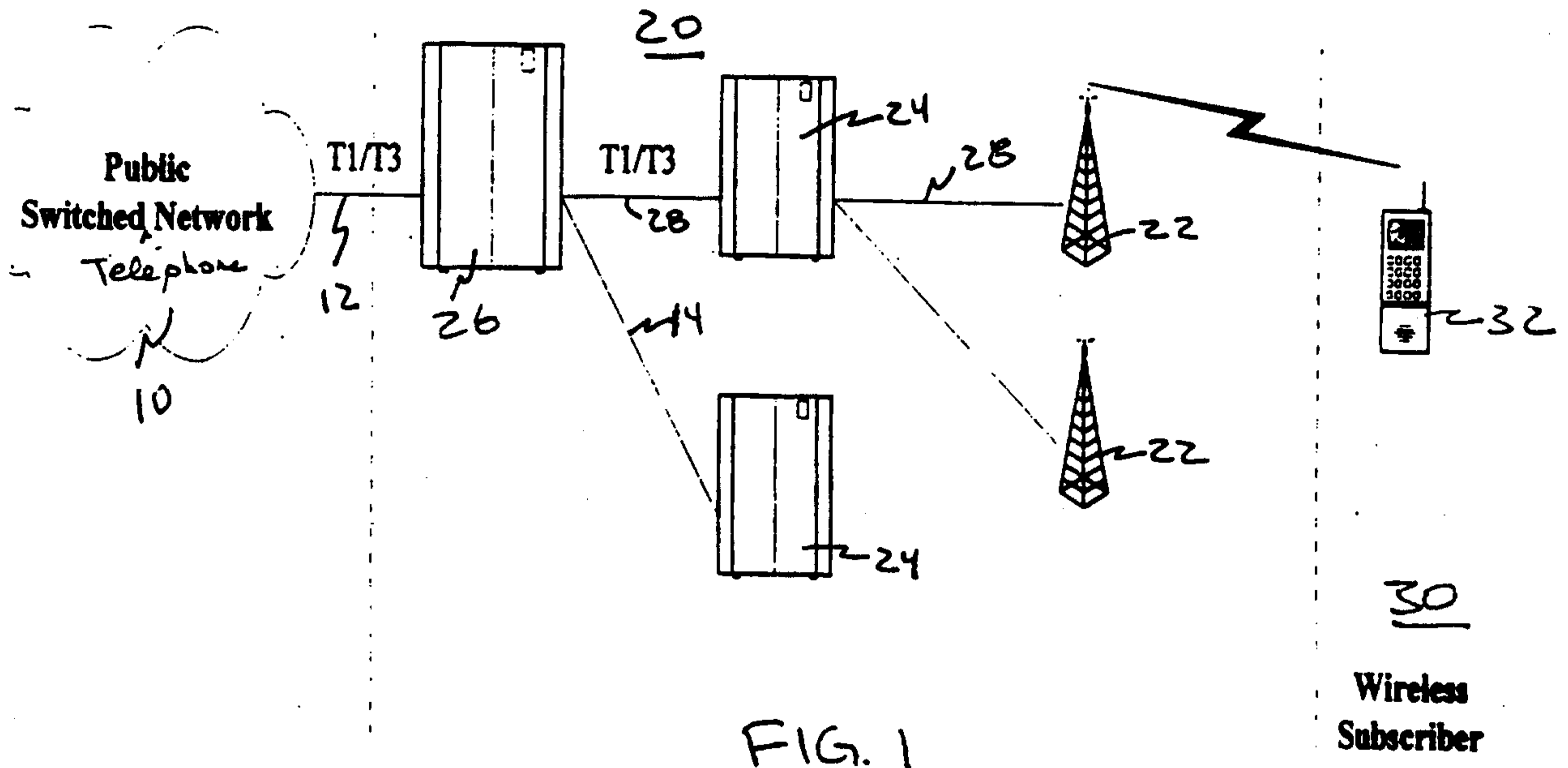

FIG. 1

2/12

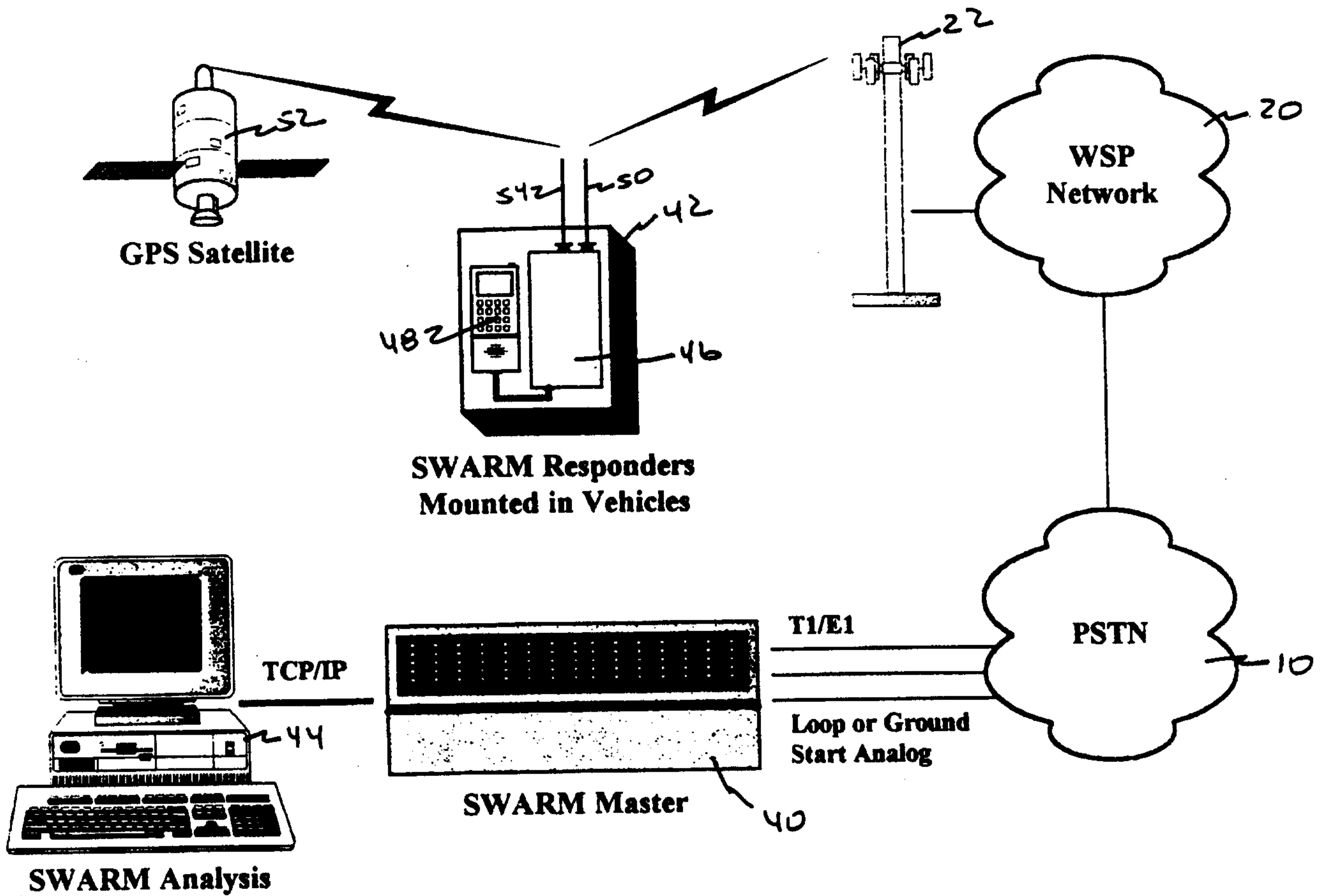

FIG. 2

3/12

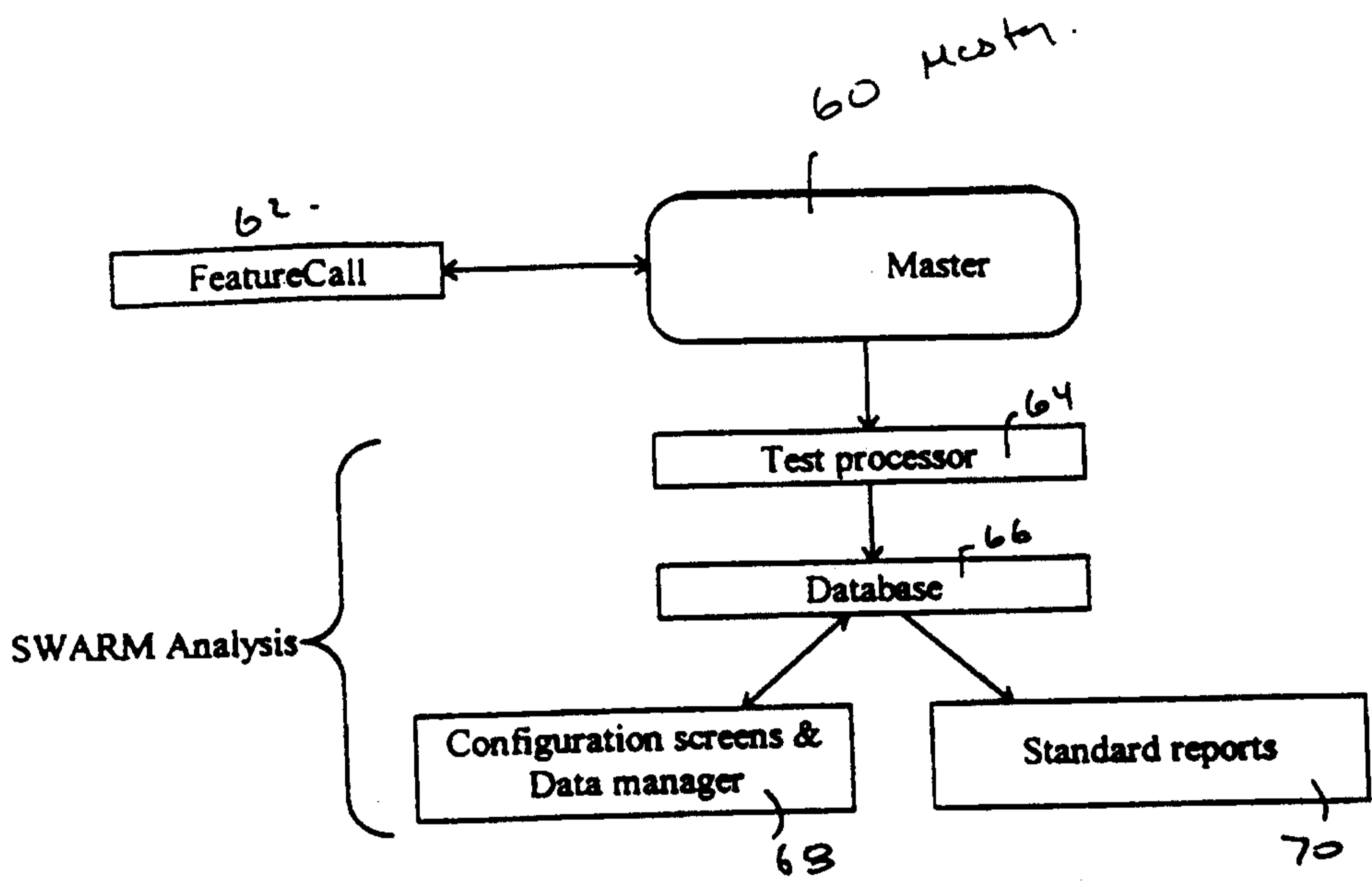

Fig. 3

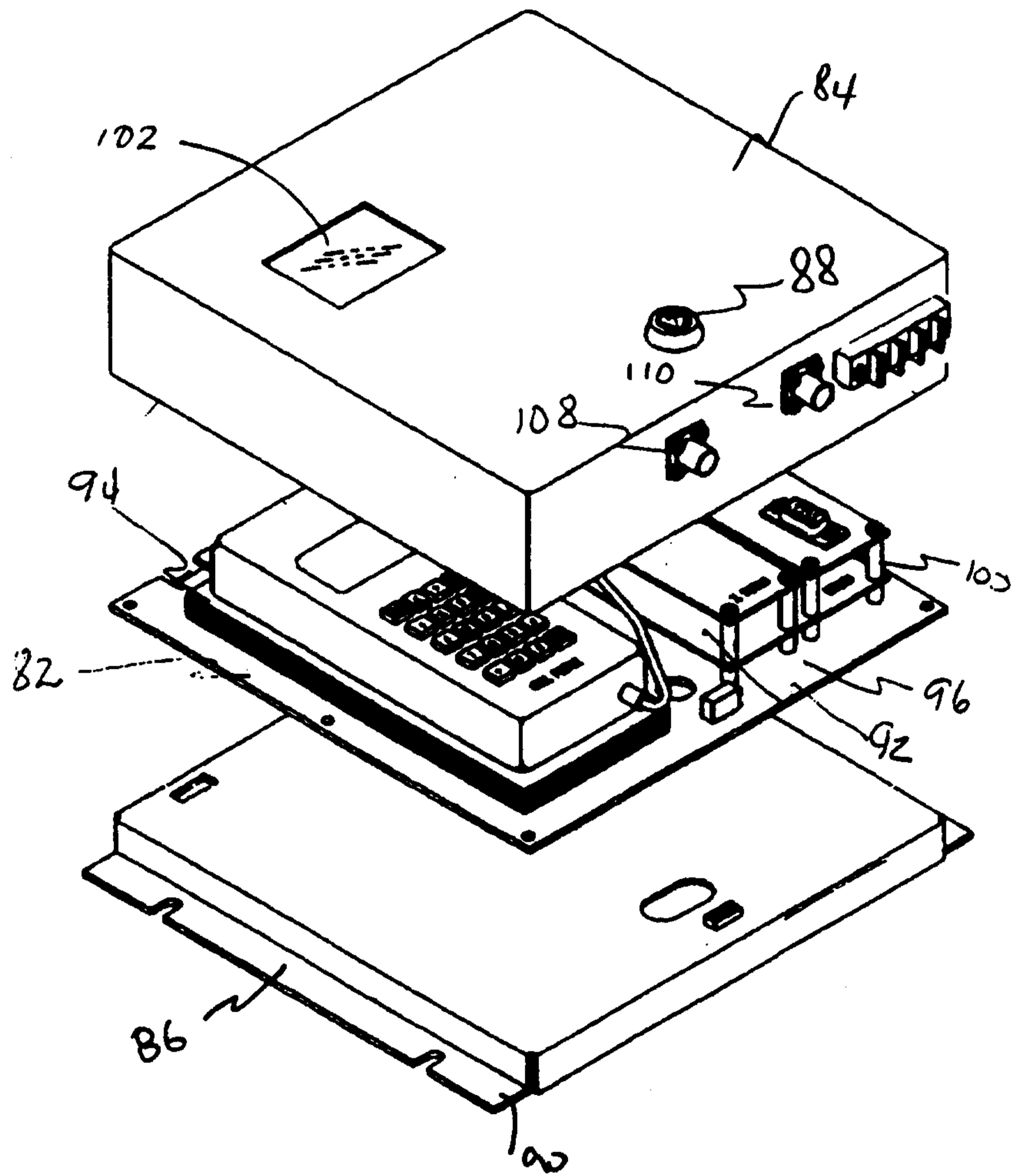

FIGURE 4

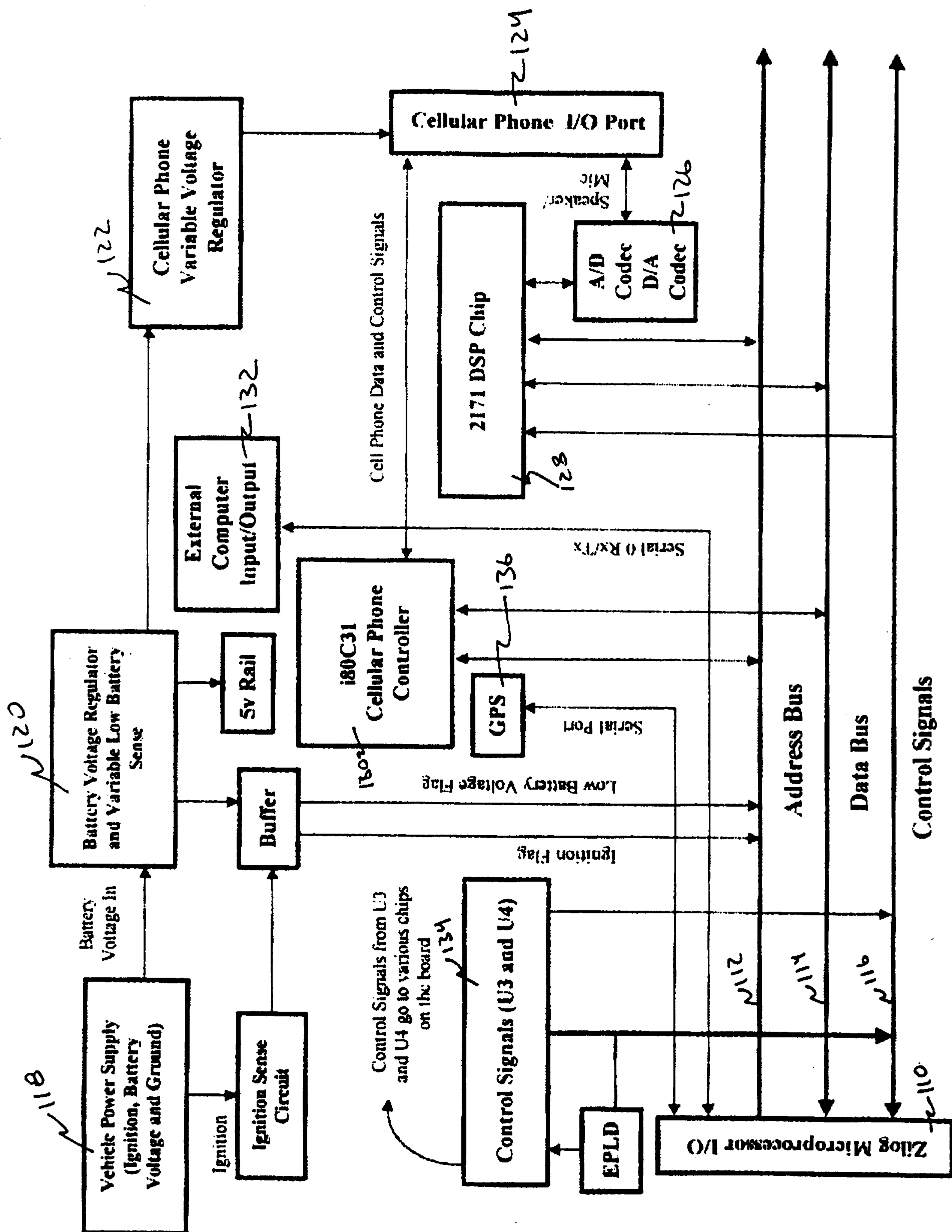

FIG. 5

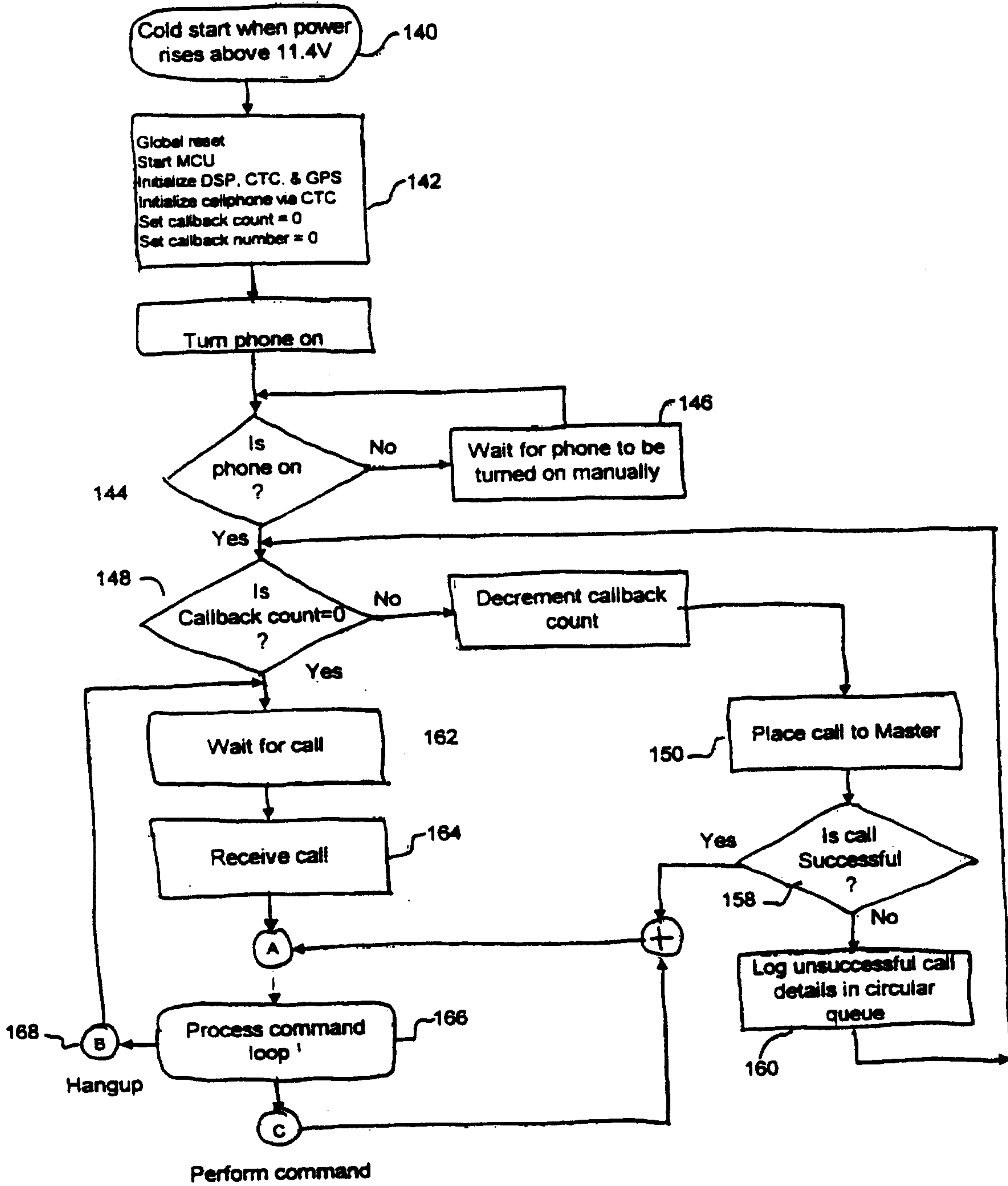
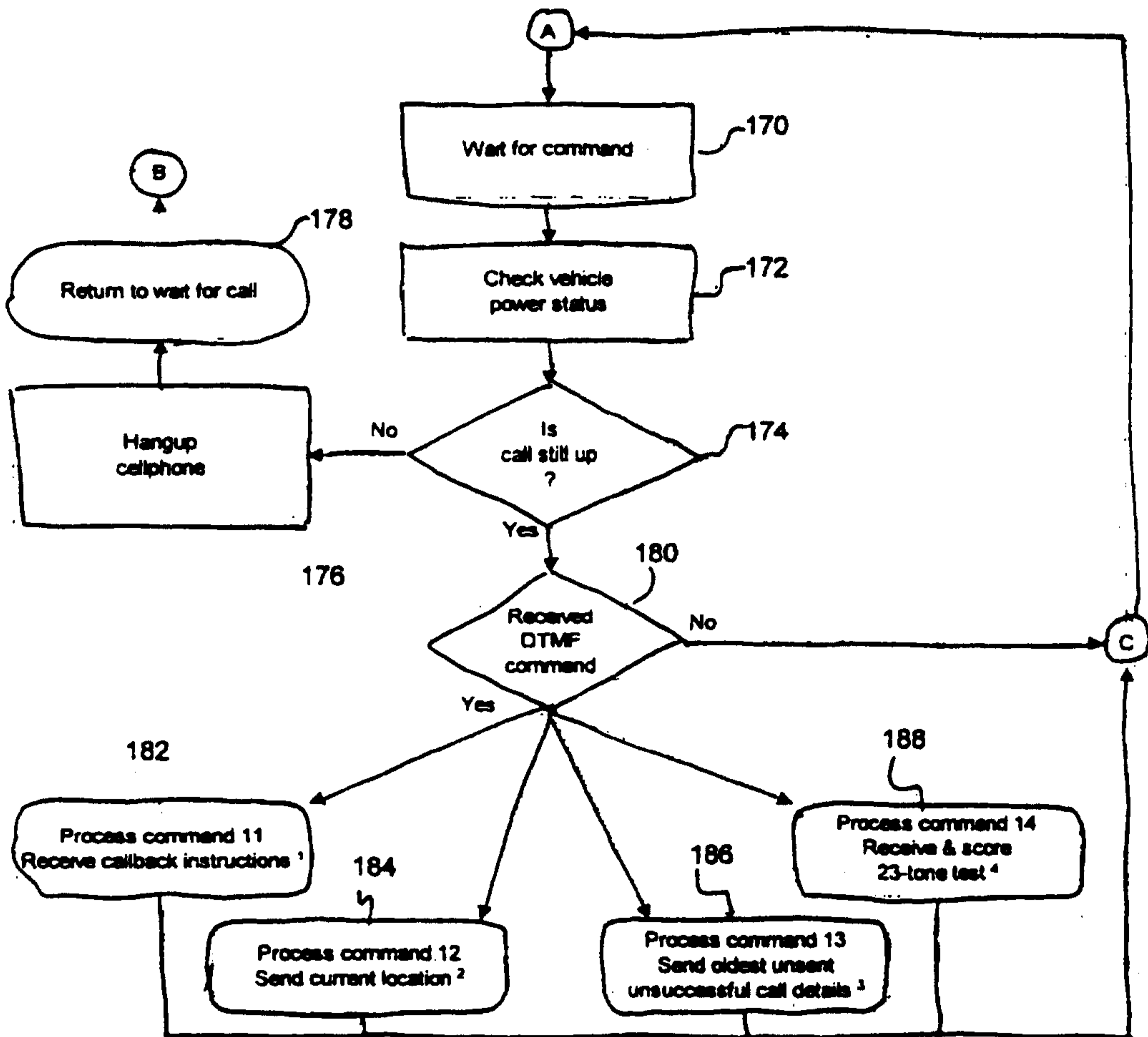

Figure 6

7/12



- 1. COMMAND SEQUENCE FLOWCHART: (1 of 4) Command 11: Receive Callback Instructions
- 2. COMMAND SEQUENCE FLOWCHART: (2 of 4) Command 12: Send Current Location
- 3. COMMAND SEQUENCE FLOWCHART: (3 of 4) Command 13: Send Oldest Unsest Unsuccessful Call Details
- 4. COMMAND SEQUENCE FLOWCHART: (4 of 4) Command 14: Receive & Score 23-Tone test

Figure 7

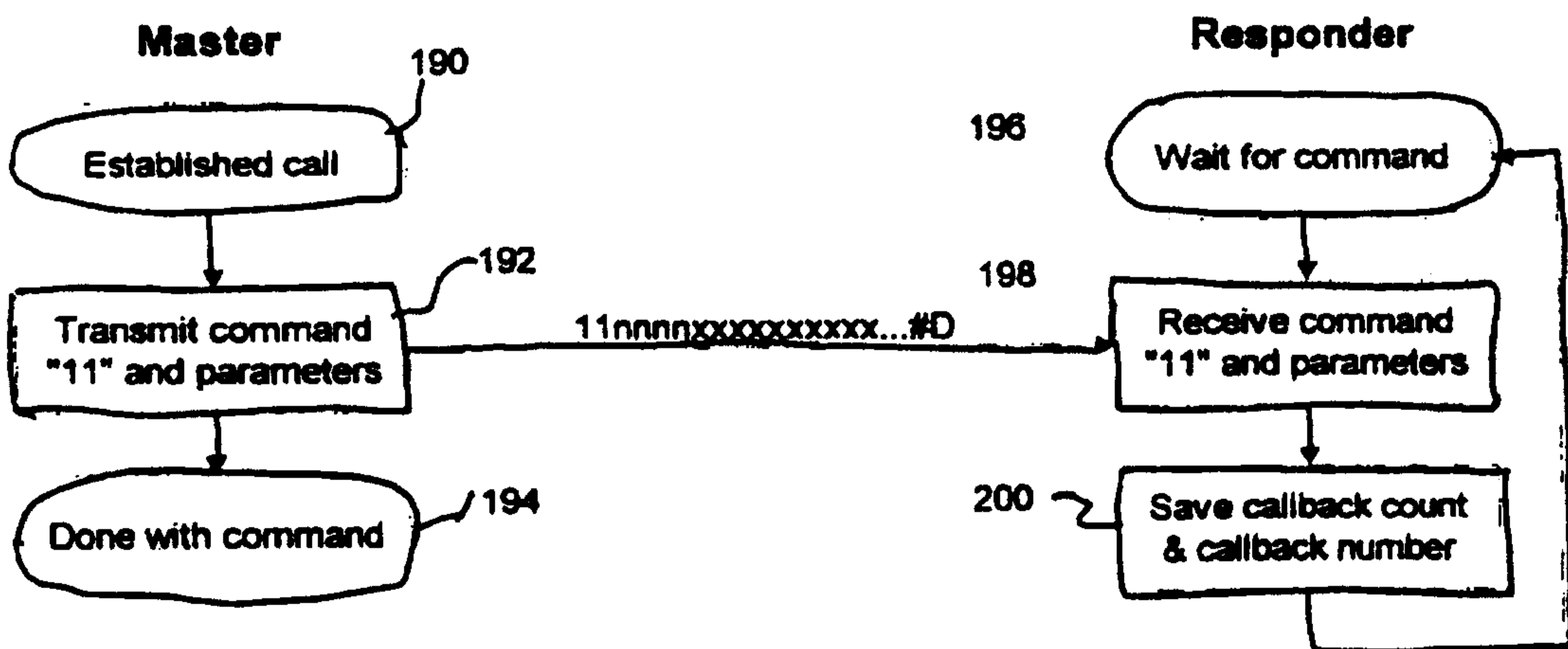

Figure 8

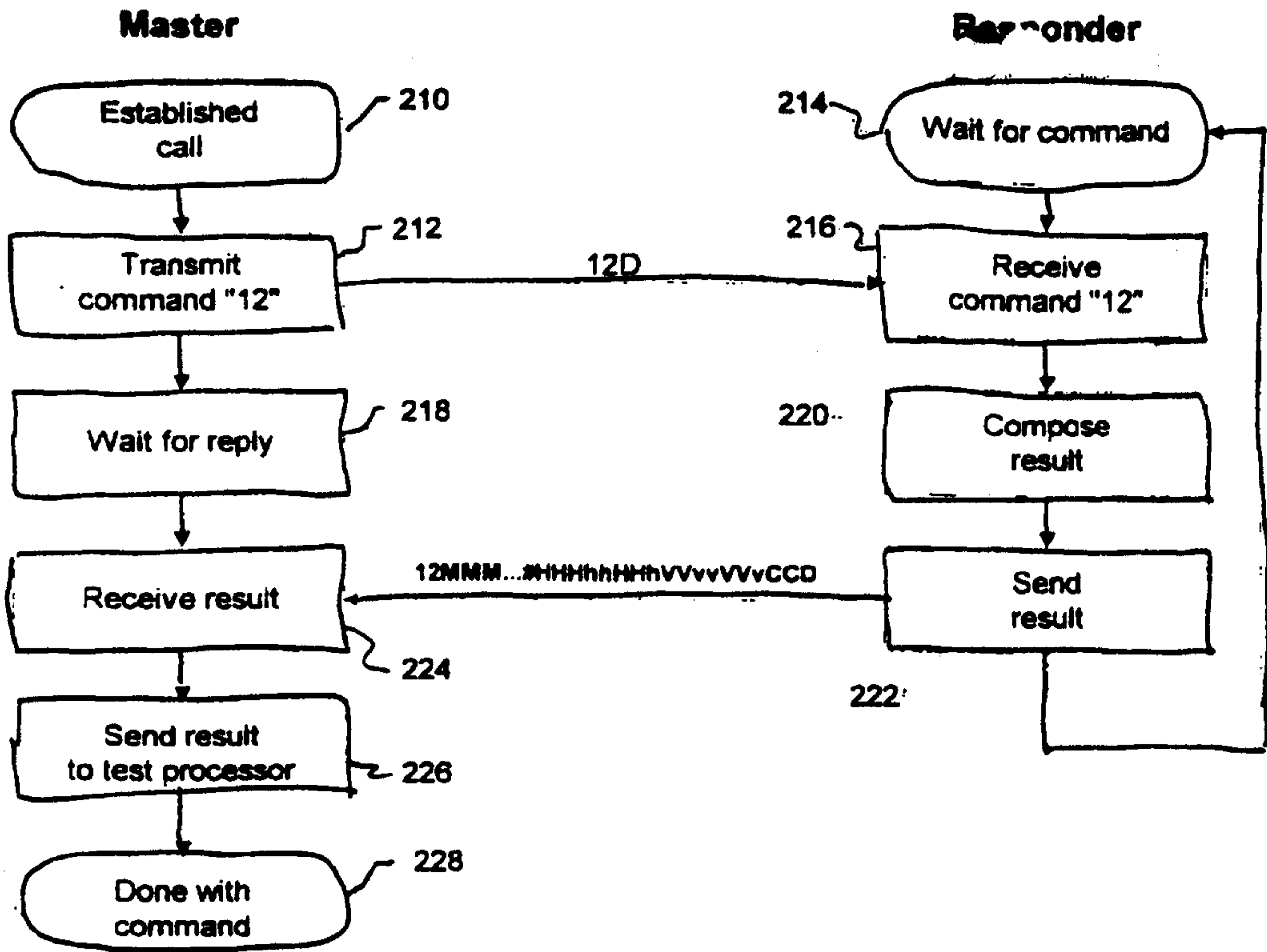

Figure 9

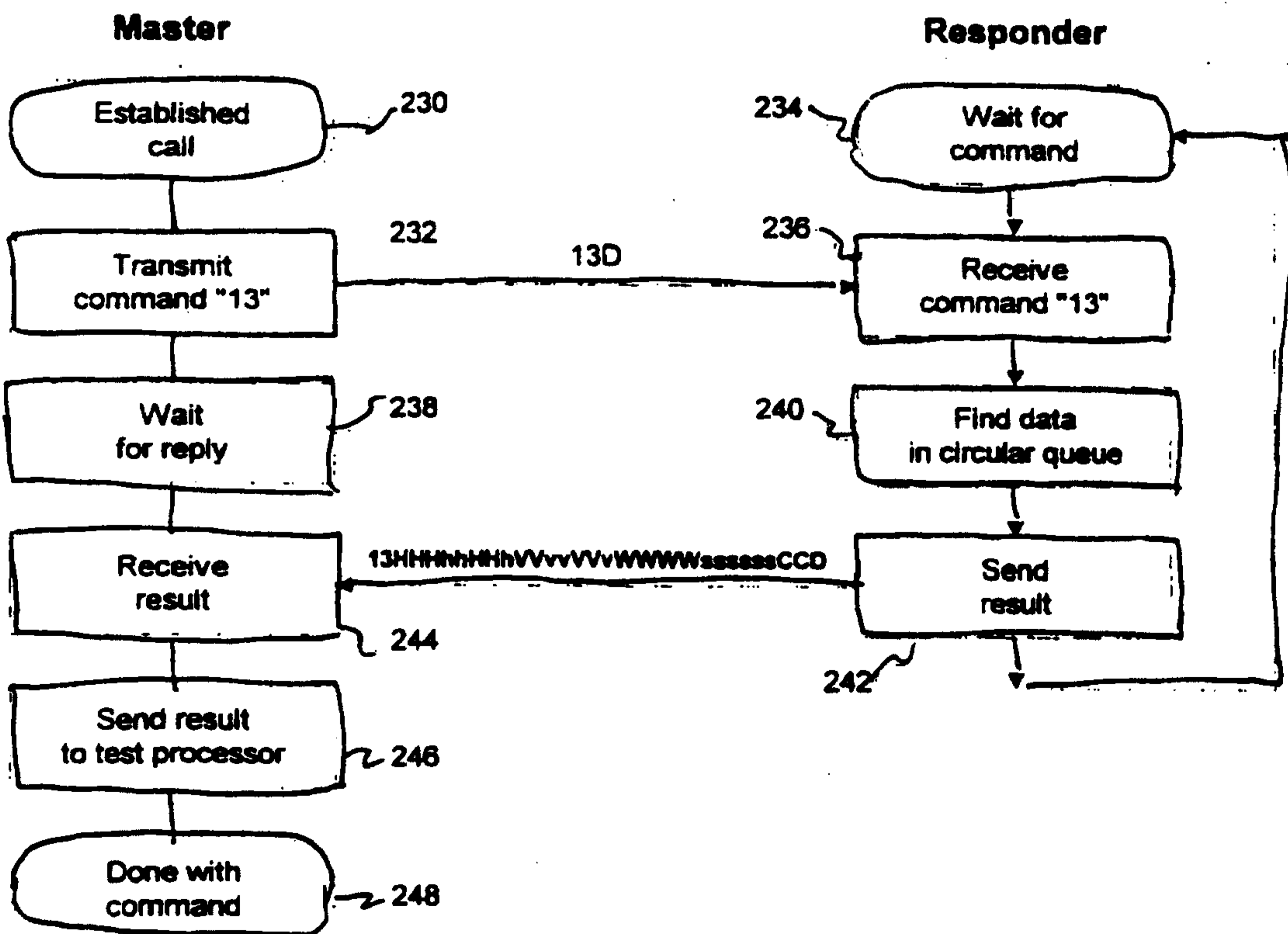

Figure 10

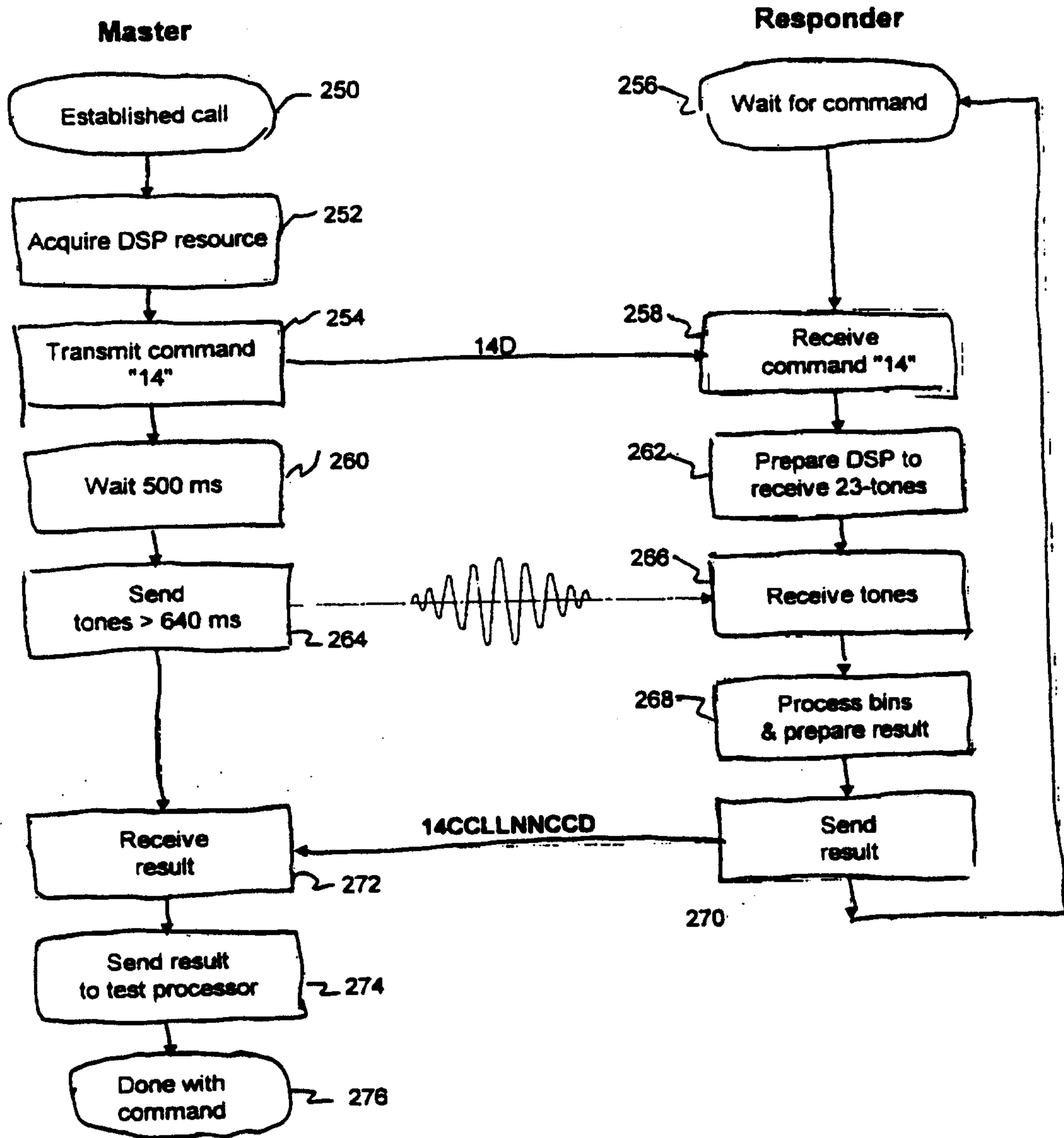

Figure 11

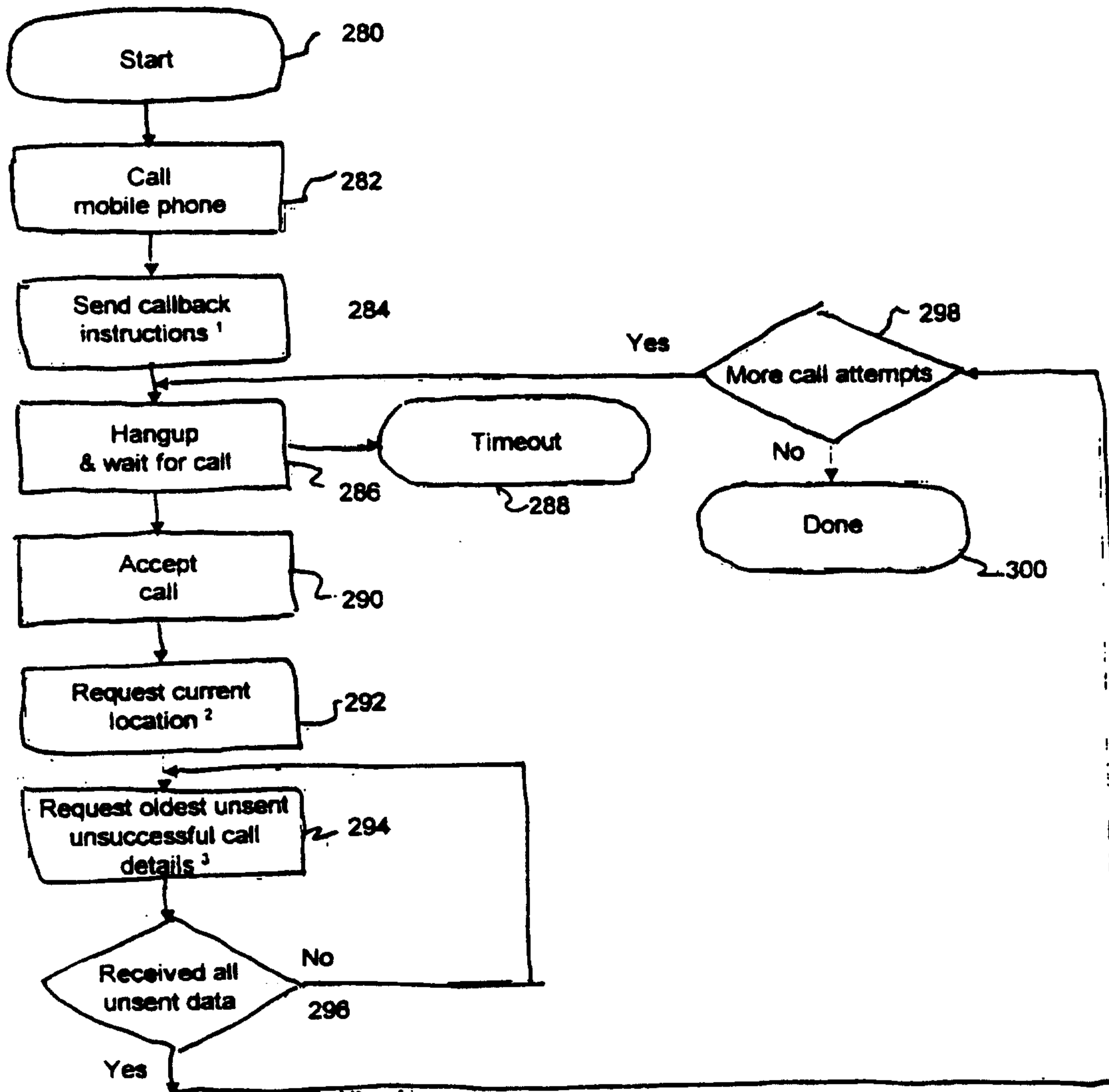

Figure 12

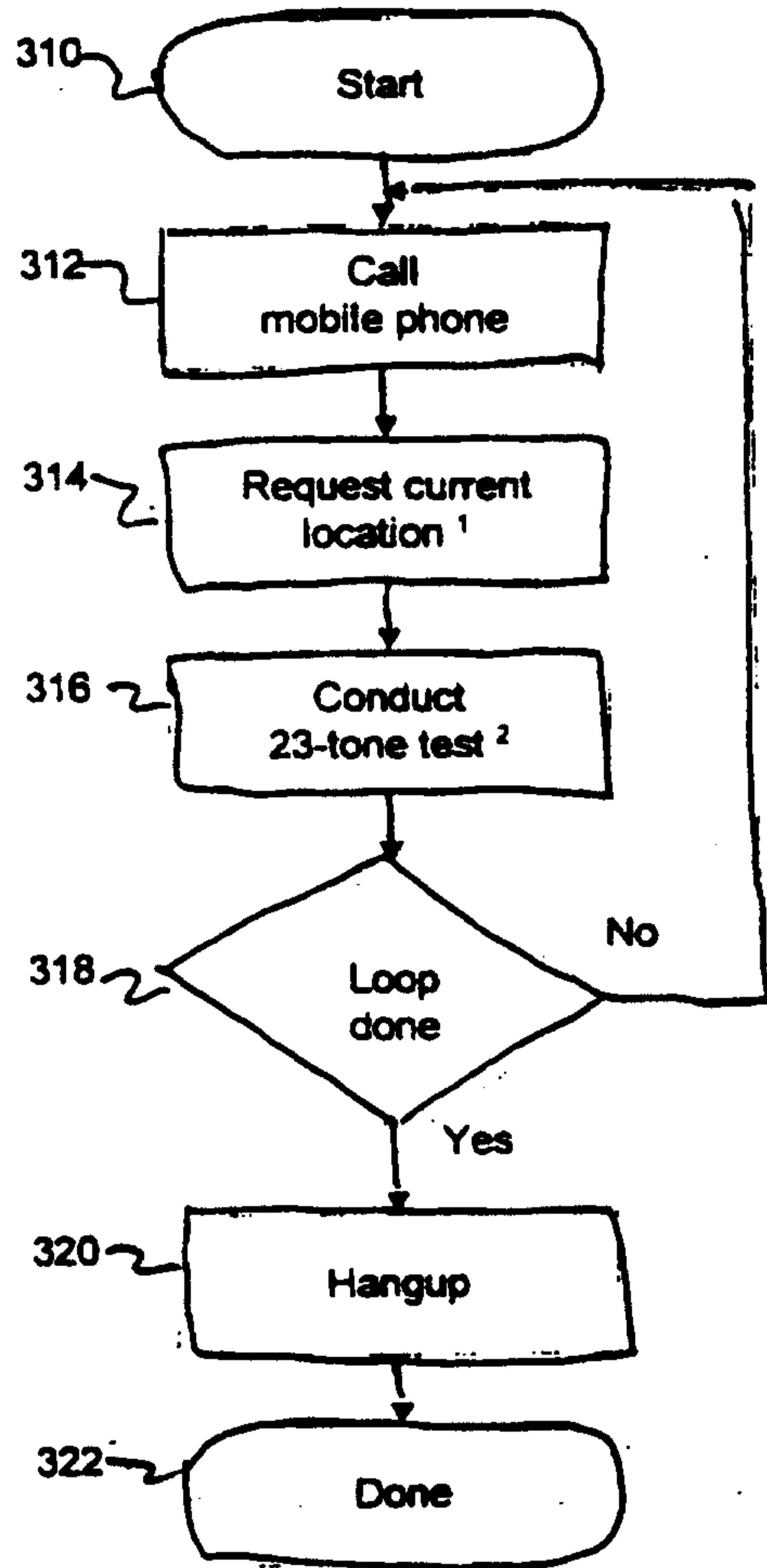

Figure 13

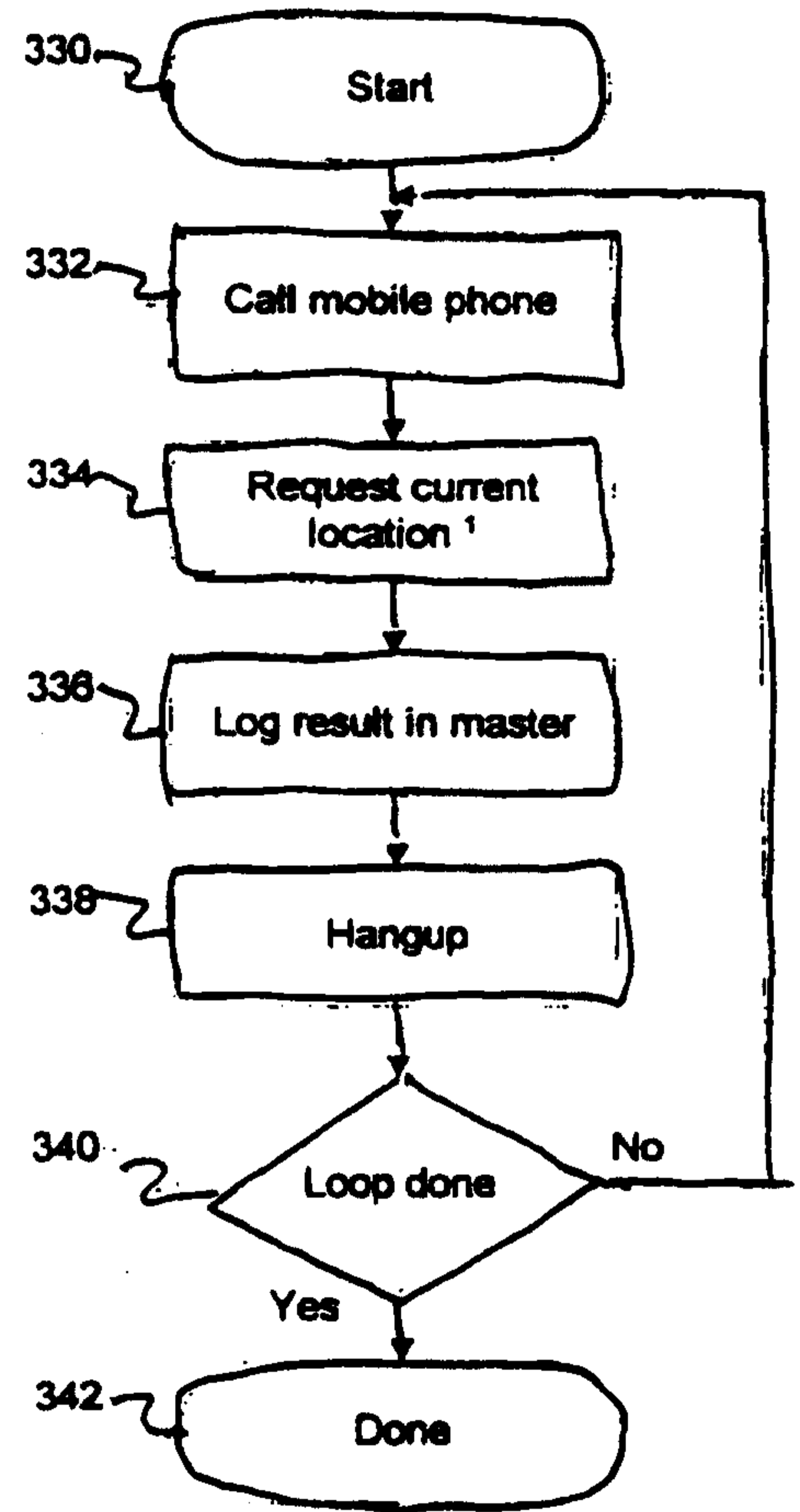

Figure 14

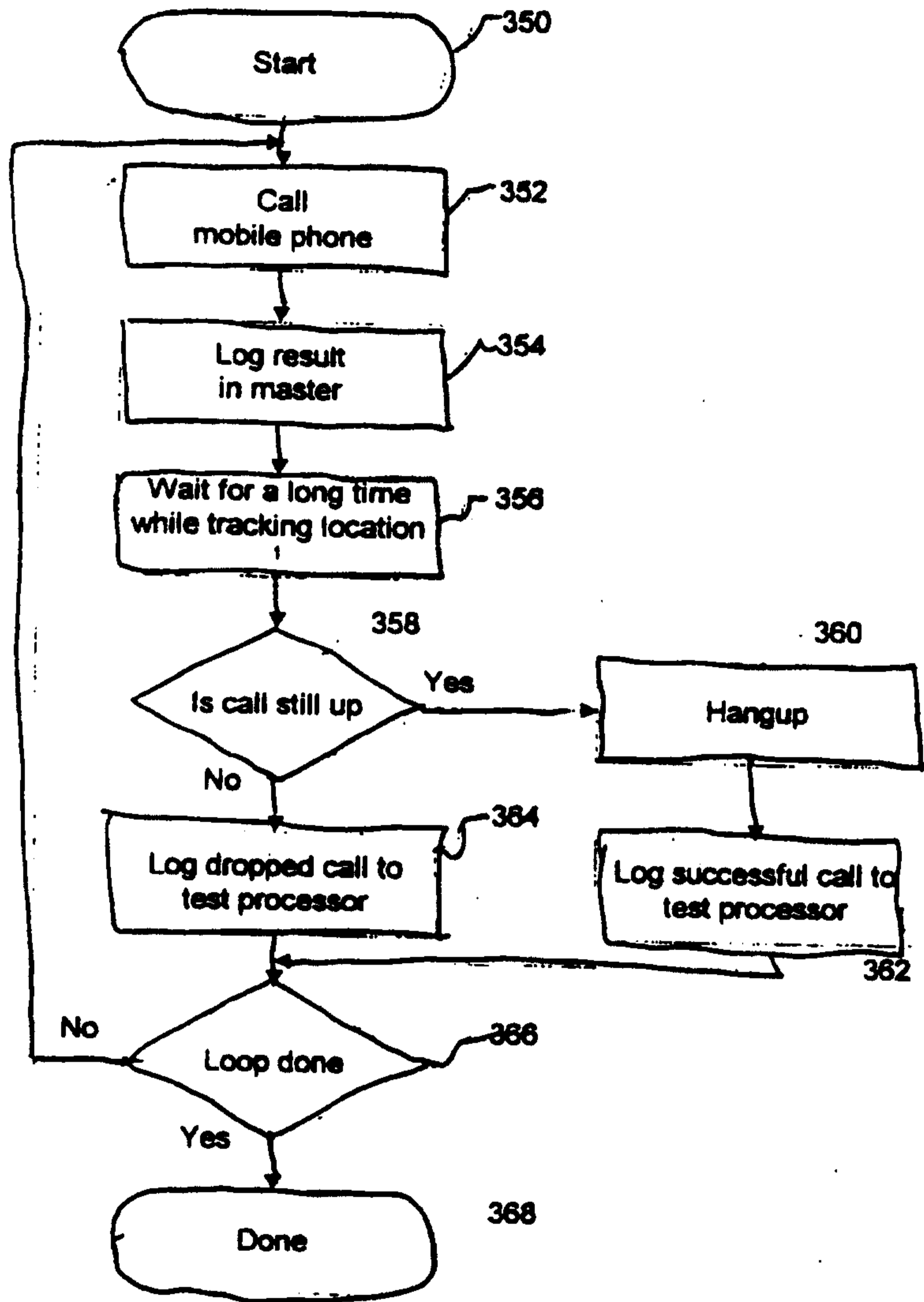

Figure 15