



US 20220171627A1

(19) **United States**

(12) **Patent Application Publication**  
**BAUM et al.**

(10) **Pub. No.: US 2022/0171627 A1**

(43) **Pub. Date: Jun. 2, 2022**

(54) **SYSTEMS AND METHODS FOR PERFORMING MATRIX COMPRESS AND DECOMPRESS INSTRUCTIONS**

continuation of application No. 16/144,902, filed on Sep. 27, 2018, now Pat. No. 10,719,323.

**Publication Classification**

(71) Applicant: **Intel Corporation**, Santa Clara, CA (US)

(51) **Int. Cl.**  
**G06F 9/30** (2006.01)  
**G06F 9/38** (2006.01)

(72) Inventors: **Dan BAUM**, Haifa (IL); **Michael ESPIG**, Newberg, OR (US); **James GUILFORD**, Northborough, MA (US); **Wajdi K. FEGHALI**, Boston, MA (US); **Raanan SADE**, Kibutz Sarid (IL); **Christopher J. HUGHES**, Santa Clara, CA (US); **Robert VALENTINE**, Kiryat Tivon (IL); **Bret TOLL**, Hillsboro, OR (US); **Elmoustapha OULD-AHMED-VALL**, Chandler, AZ (US); **Mark J. CHARNEY**, Lexington, MA (US); **Vinodh GOPAL**, Westborough, MA (US); **Ronen ZOCHAR**, Sunnyvale, CA (US); **Alexander F. HEINECKE**, San Jose, CA (US)

(52) **U.S. Cl.**  
CPC ..... **G06F 9/30178** (2013.01); **G06F 9/30145** (2013.01); **G06F 9/3802** (2013.01); **G06F 9/3013** (2013.01); **G06F 9/30036** (2013.01)

(57) **ABSTRACT**

Disclosed embodiments relate to matrix compress/decompress instructions. In one example, a processor includes fetch circuitry to fetch a compress instruction having a format with fields to specify an opcode and locations of decompressed source and compressed destination matrices, decode circuitry to decode the fetched compress instructions, and execution circuitry, responsive to the decoded compress instruction, to: generate a compressed result according to a compress algorithm by compressing the specified decompressed source matrix by either packing non-zero-valued elements together and storing the matrix position of each non-zero-valued element in a header, or using fewer bits to represent one or more elements and using the header to identify matrix elements being represented by fewer bits; and store the compressed result to the specified compressed destination matrix.

(21) Appl. No.: **17/672,253**

(22) Filed: **Feb. 15, 2022**

**Related U.S. Application Data**

(63) Continuation of application No. 16/934,003, filed on Jul. 20, 2020, now Pat. No. 11,249,761, which is a

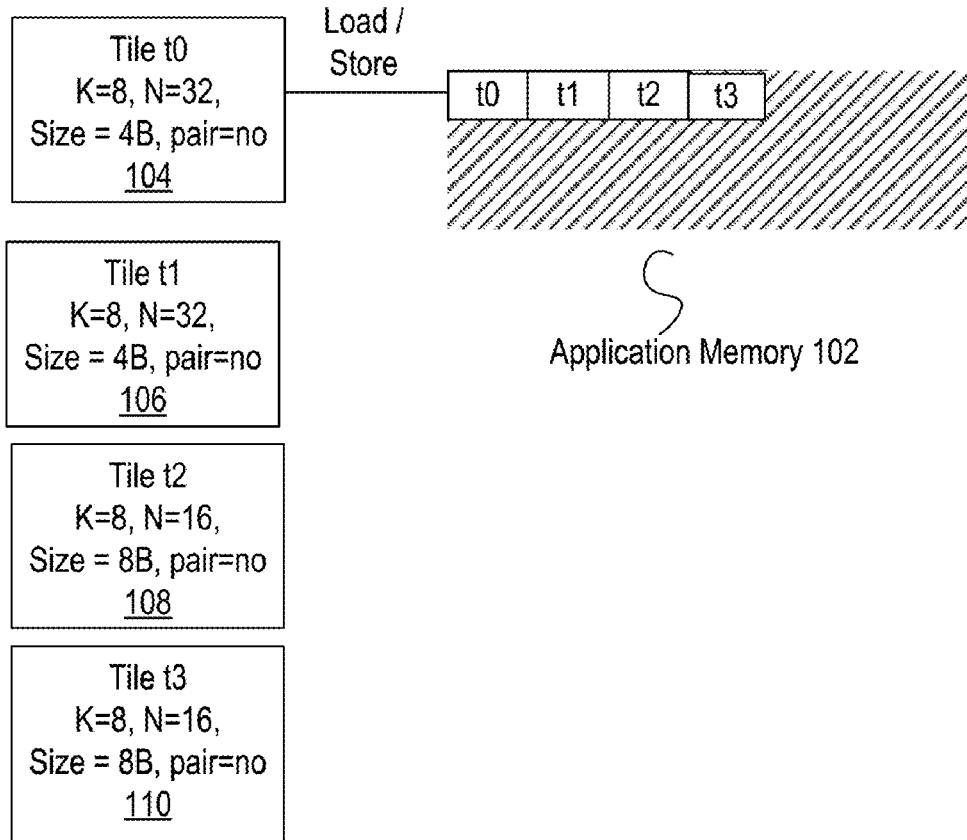

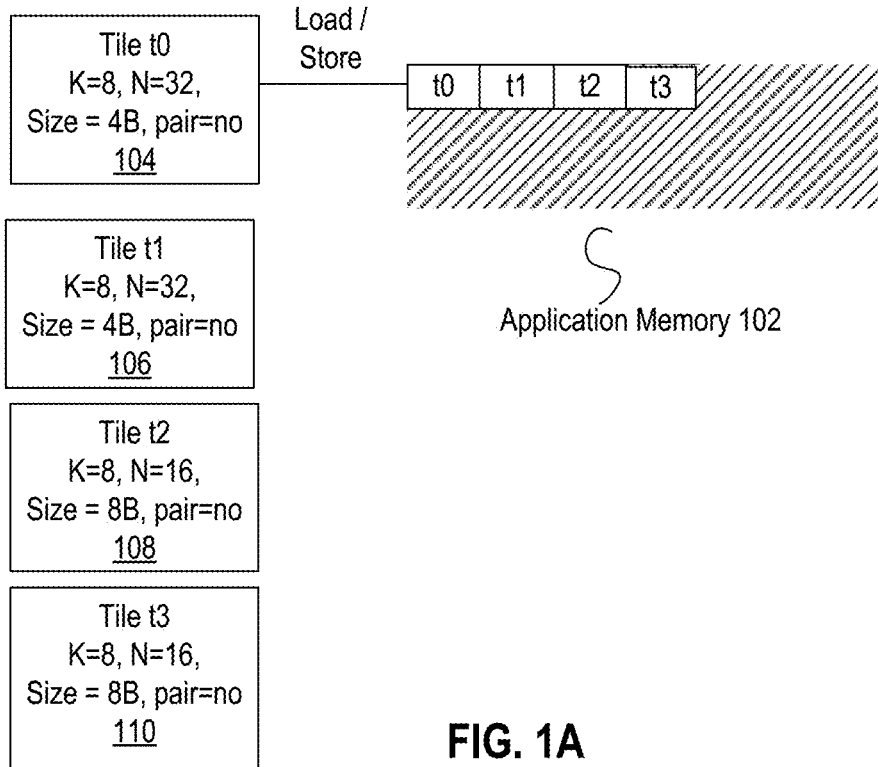

FIG. 1A

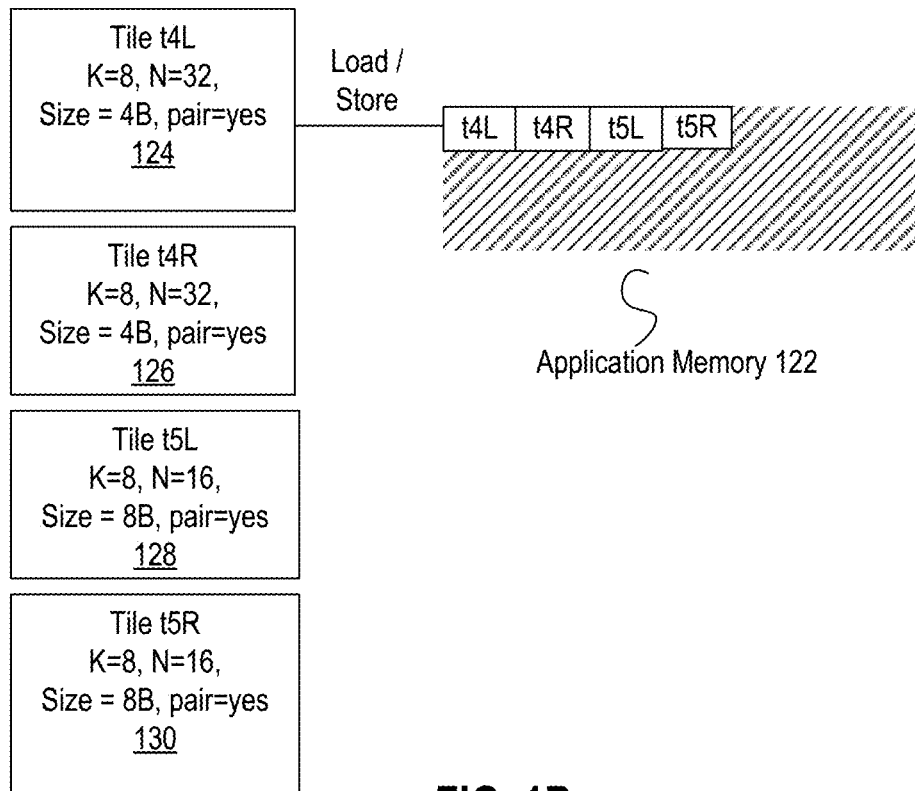

FIG. 1B

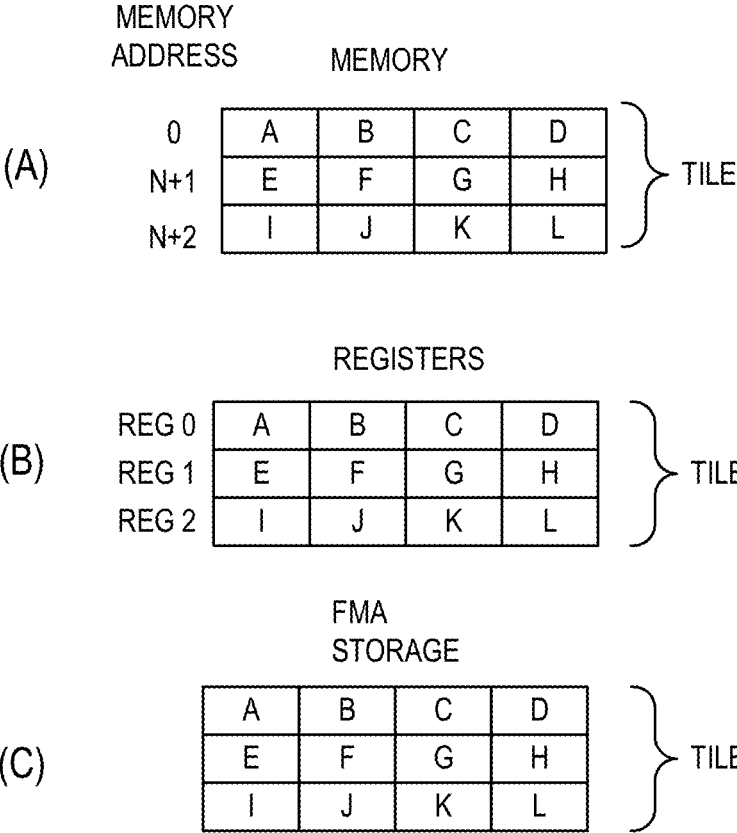

FIG. 2

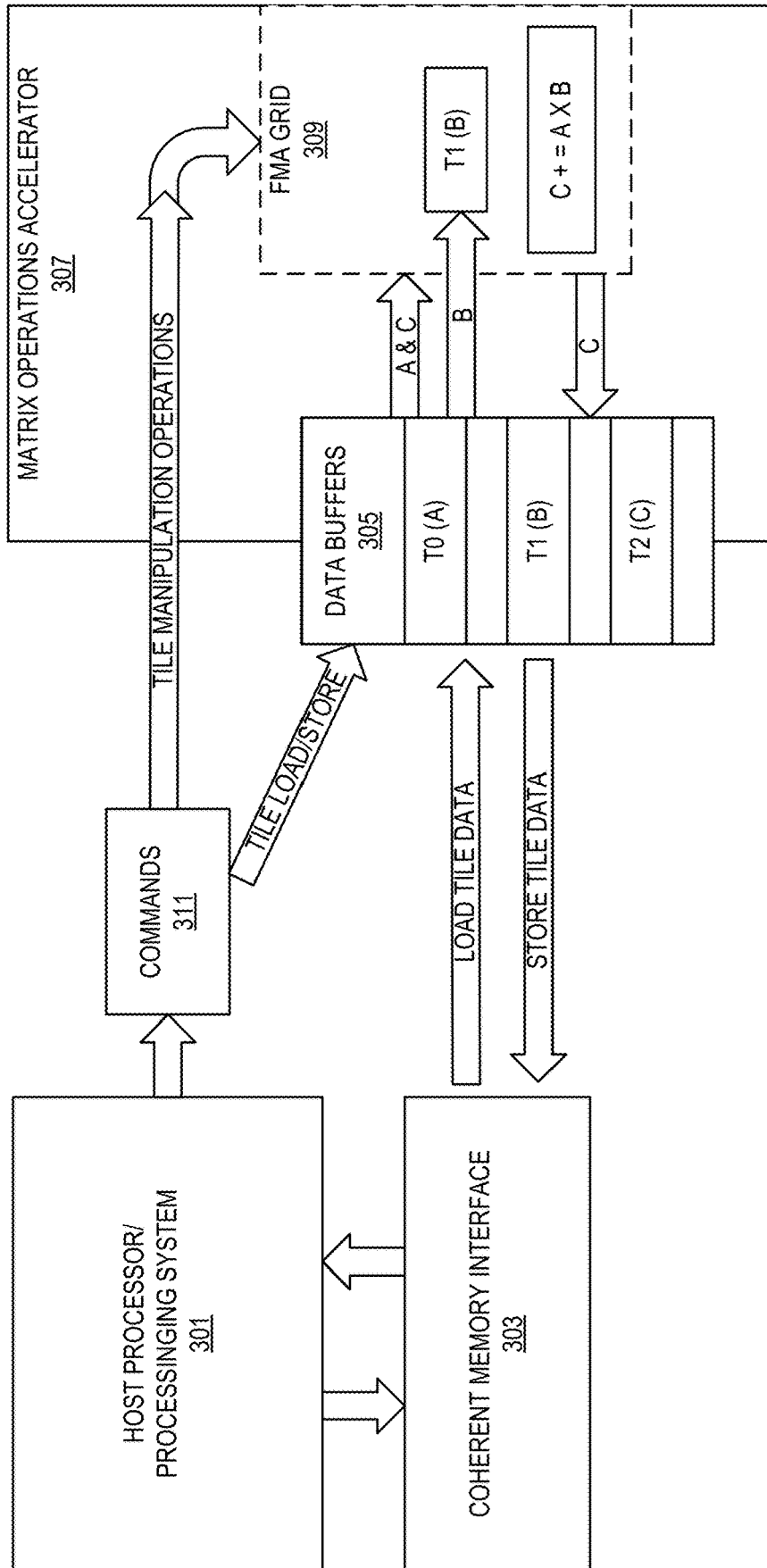

FIG. 3

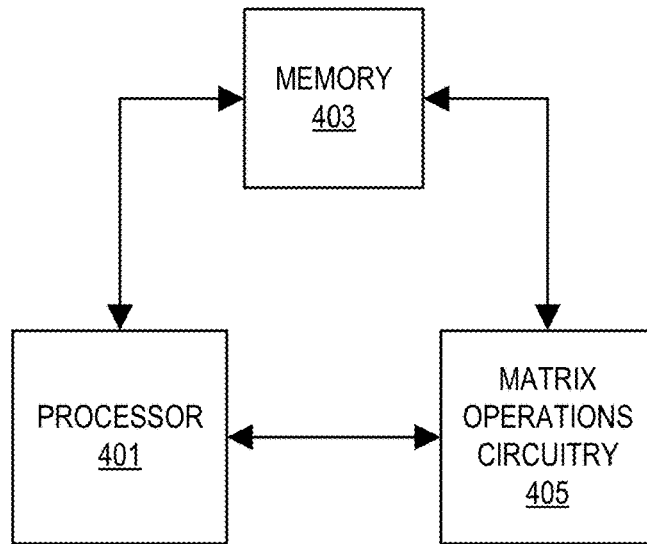

FIG. 4

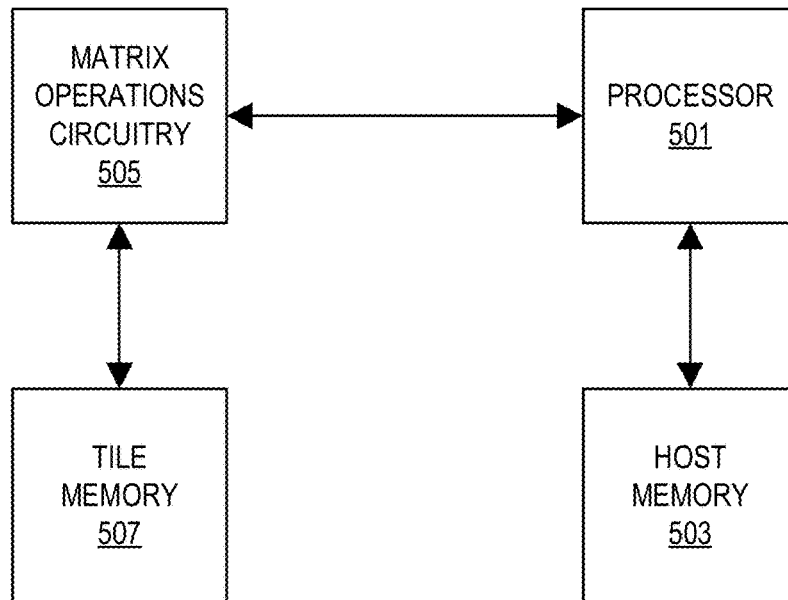

FIG. 5

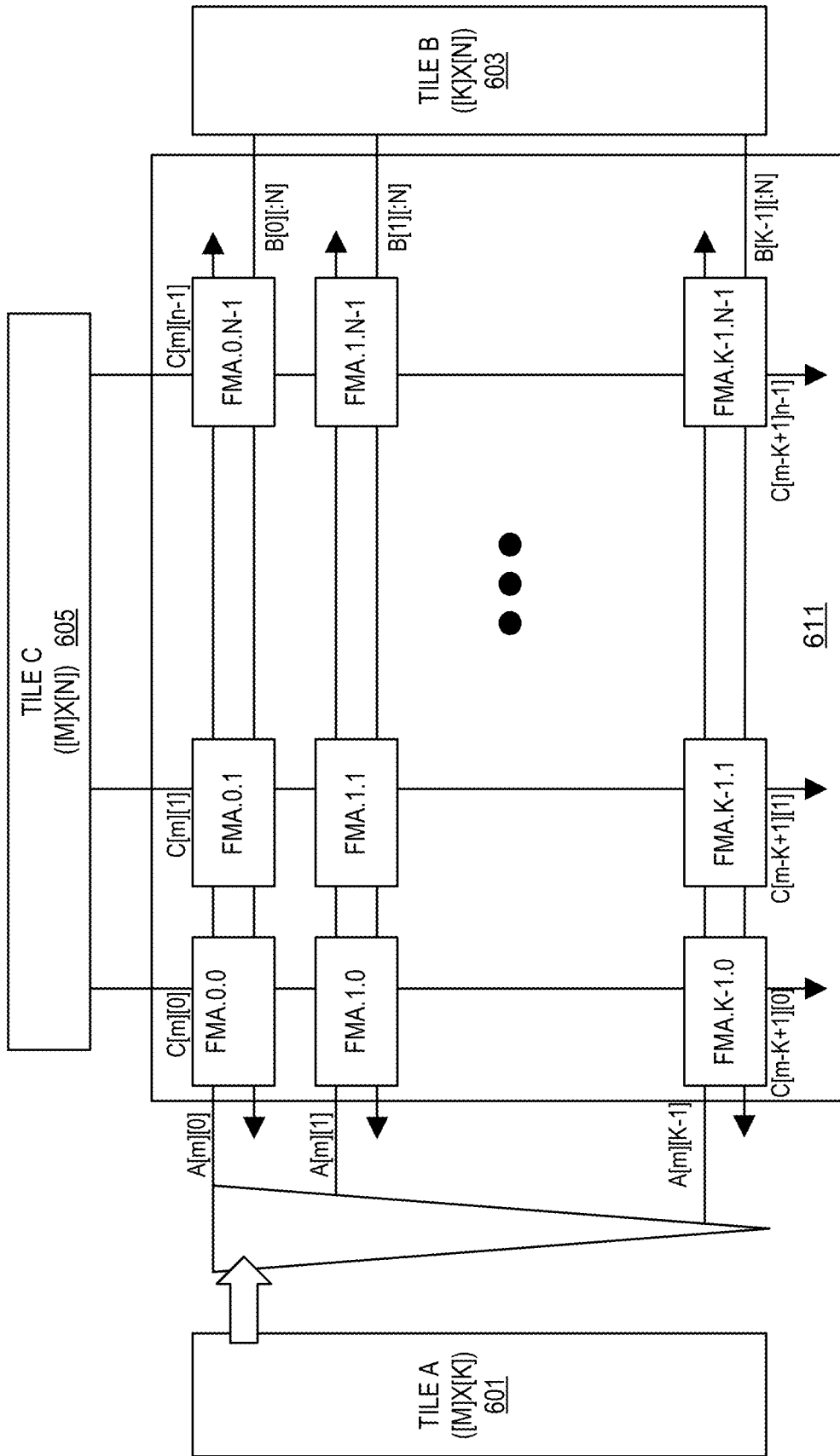

FIG. 6

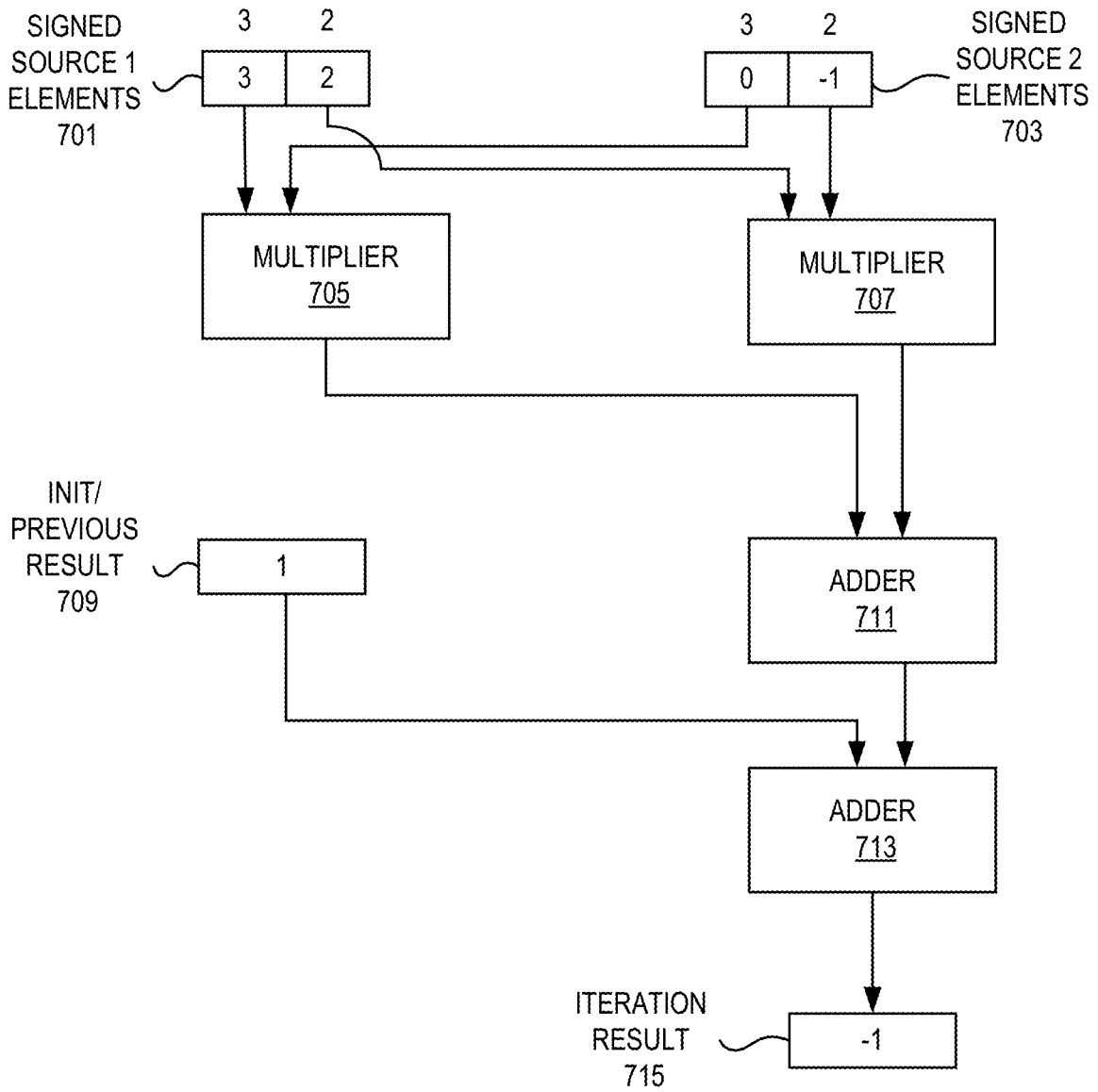

FIG. 7

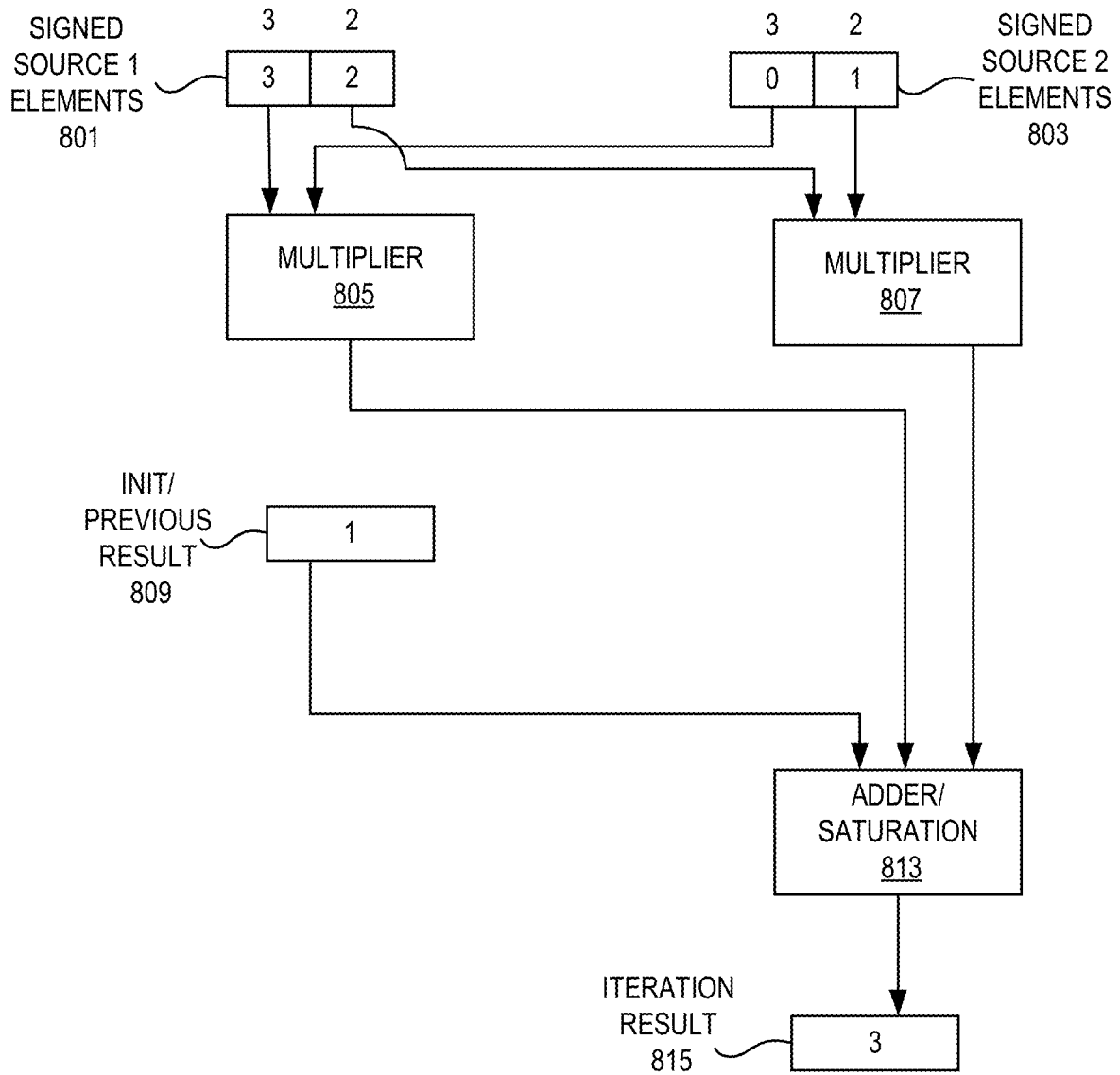

FIG. 8



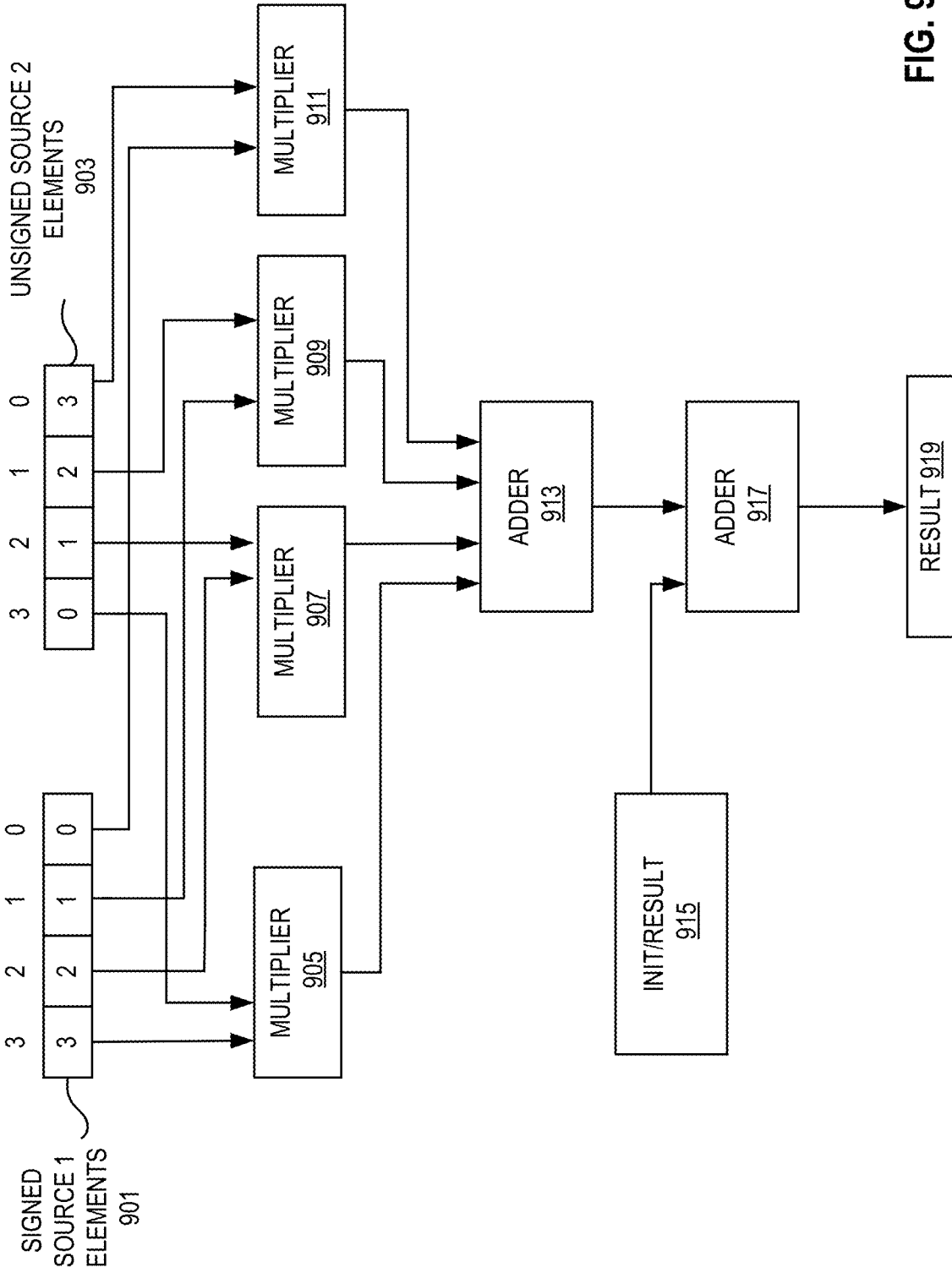

FIG. 9

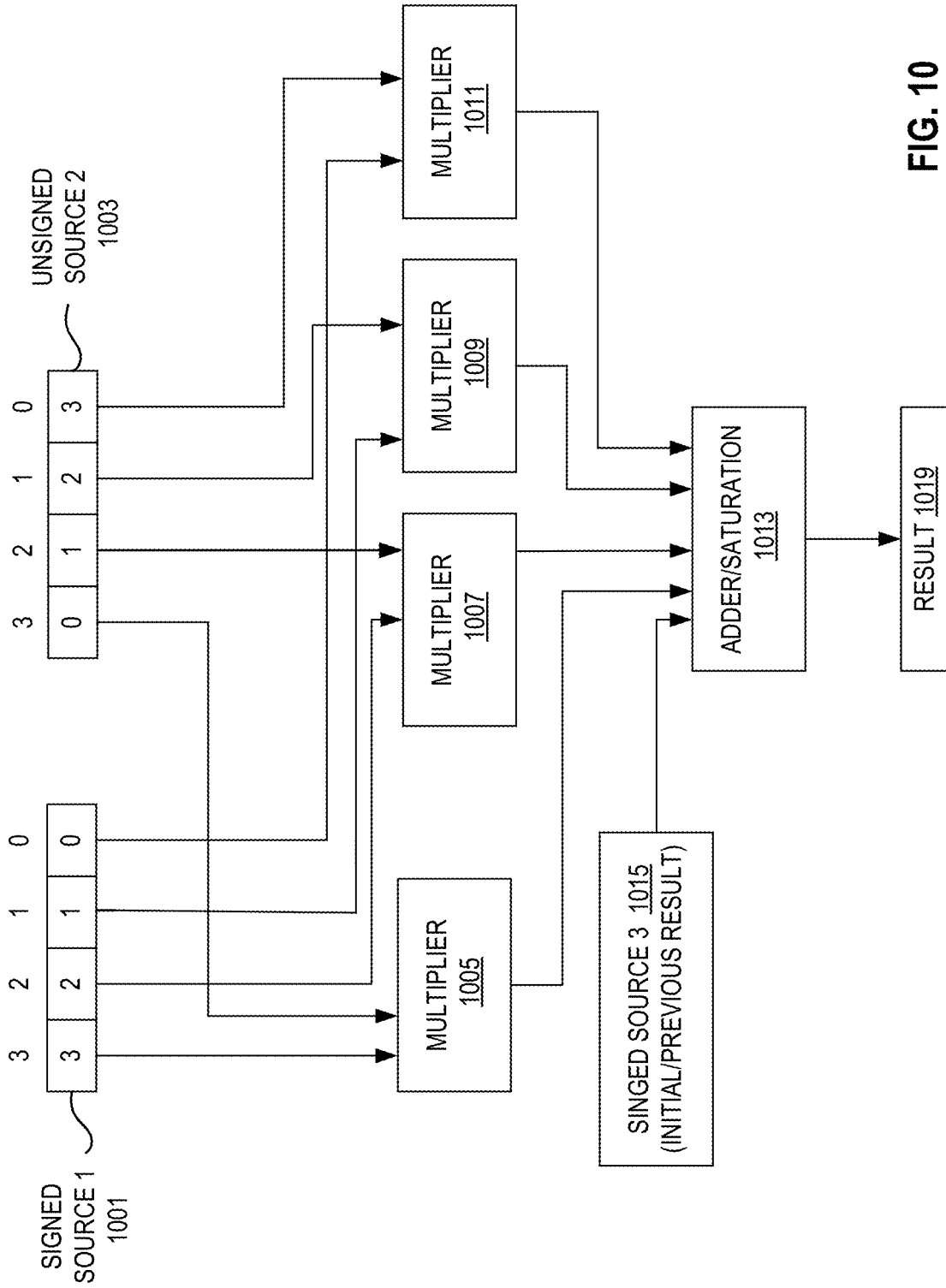

FIG. 10

ACCUMULATOR 2X INPUT SIZES 1101

SOURCES	BITS	ACCUMULATOR	BITS
BYTE	8	WORD/HPFP	16
WORD	16	INT32/SPFP	32
SPFP/INT32	32	INT64/DPFP	64

ACCUMULATOR 4X INPUT SIZES 1103

SOURCES	BITS	ACCUMULATOR	BITS
BYTE	8	INT32/SPFP	32
WORD	16	INT64/DPFP	64

ACCUMULATOR 8X INPUT SIZES 1105

SOURCES	BITS	ACCUMULATOR	BITS
BYTE	8	INT64/DPFP	64

FIG. 11

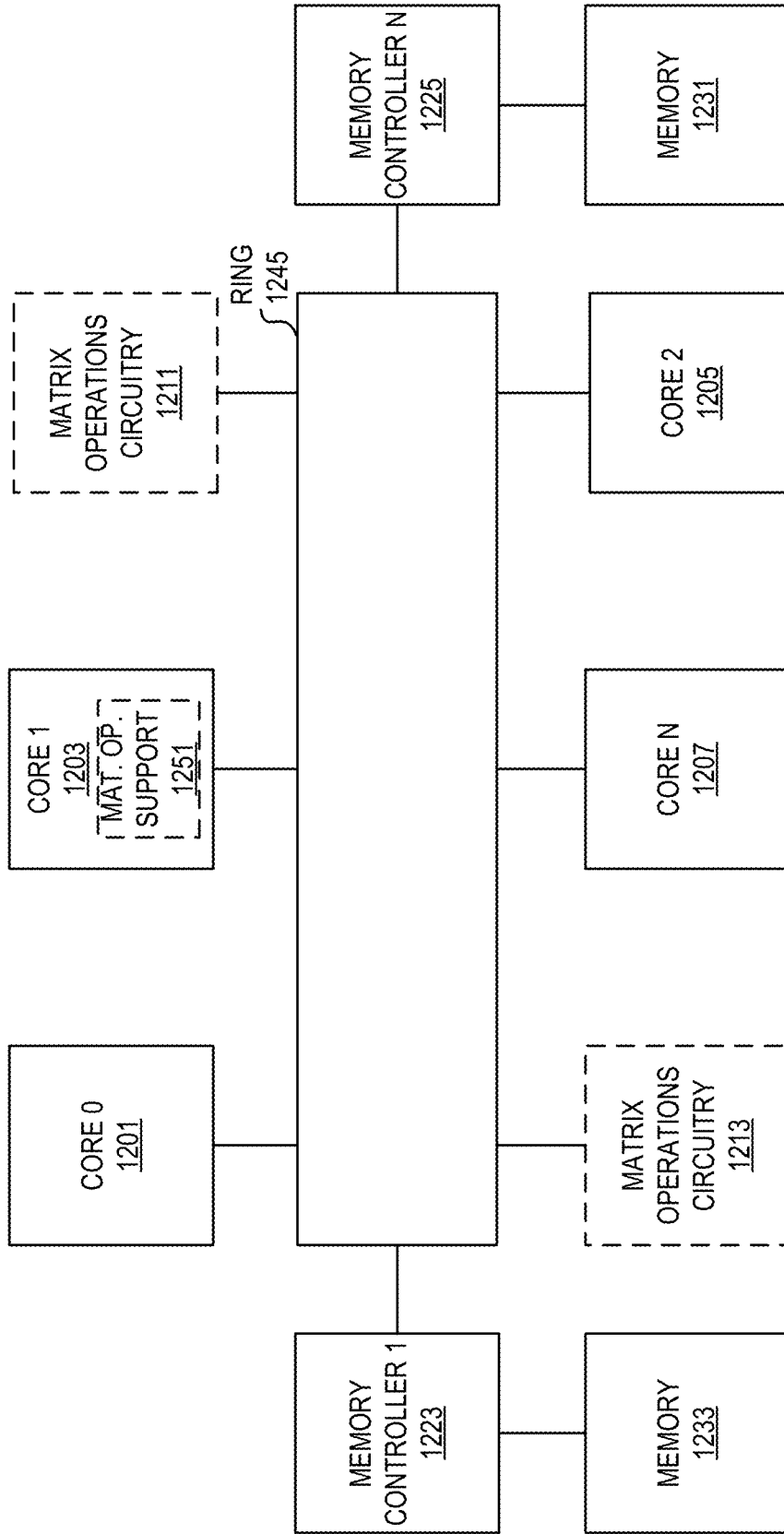

FIG. 12

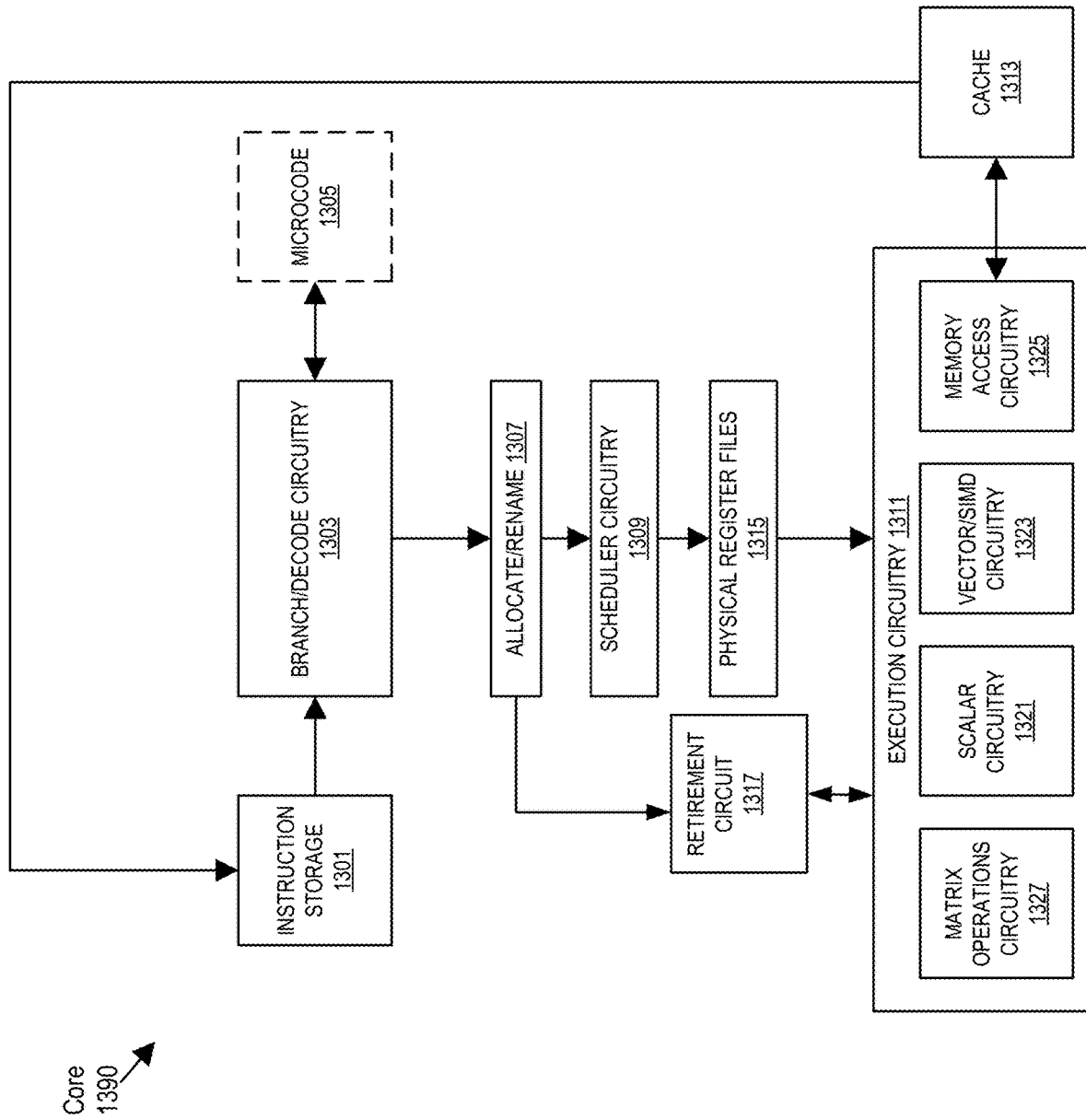

FIG. 13

Core  
1490

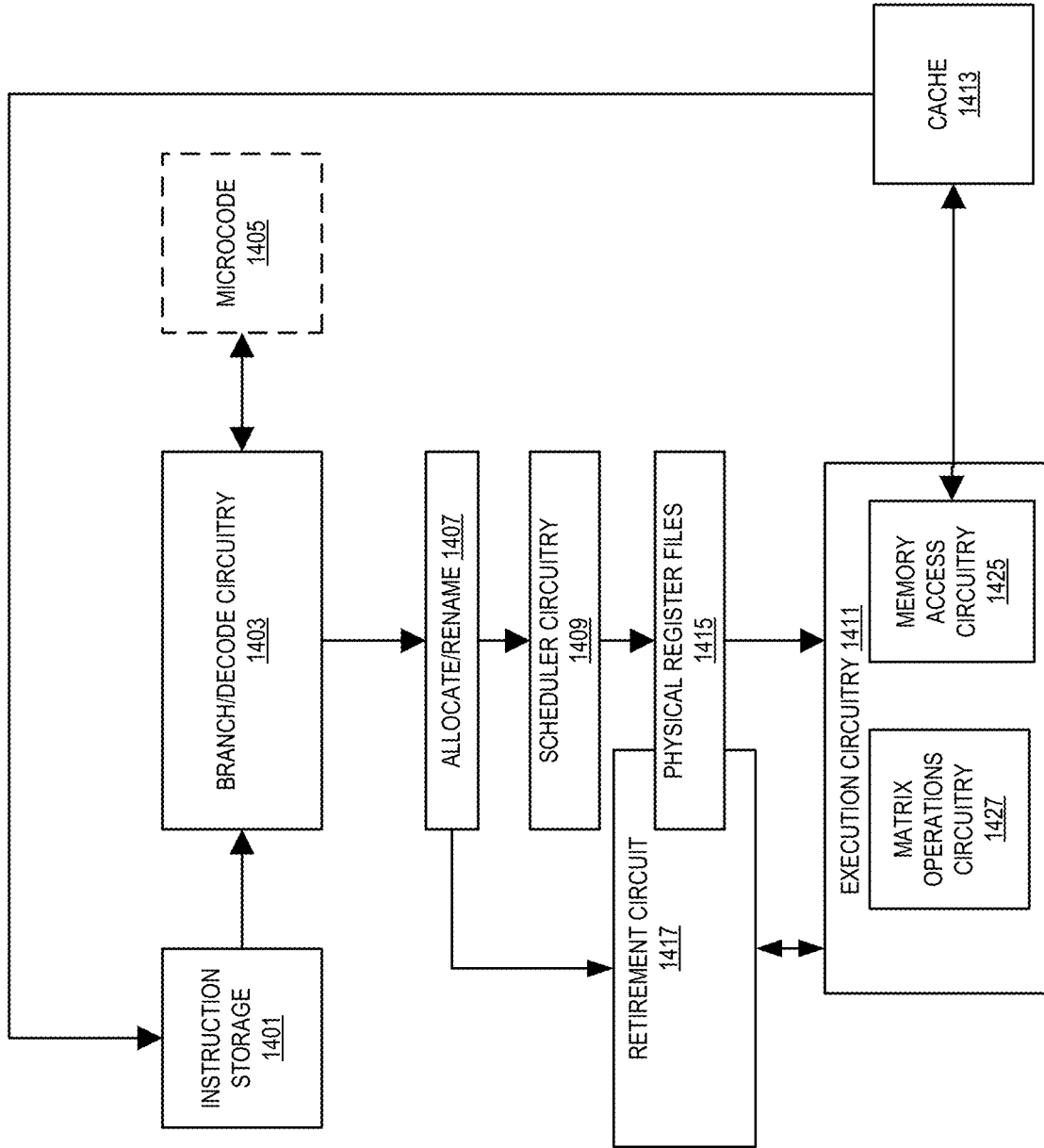

FIG. 14

$$A = \begin{bmatrix} A_{11} & A_{12} & A_{13} \\ A_{21} & A_{22} & A_{23} \end{bmatrix}$$

ADDR	VALUE
0	$A_{11}$
1	$A_{12}$
2	$A_{13}$
3	$A_{21}$
4	$A_{22}$
5	$A_{23}$

ROW MAJOR

ADDR	VALUE
0	$A_{11}$
1	$A_{21}$
2	$A_{12}$
3	$A_{22}$
4	$A_{13}$
5	$A_{23}$

COLUMN MAJOR

FIG. 15

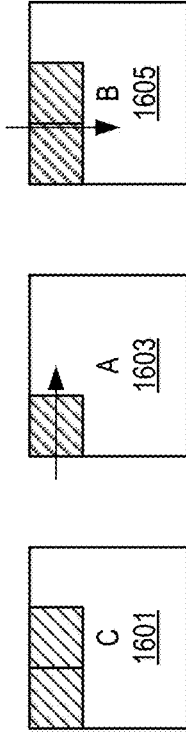

```

TILECONFIG [RAX]
// ASSUME SOME OUTER LOOPS DRIVING THE CACHE TILING (NOT SHOWN)
{
    TILELOAD TMM0, RSI+RDI // SRCDST, RSI POINTS TO C, RDI HAS
    TILELOAD TMM1, RSI+RDI+N // SECOND TILE OF C, UNROLLING IN SIMD DIMENSION N
    MOV KK, 0
    LOOP:
    TILELOAD TMM2, R8+R9 // SRC2 IS STRIDED LOAD OF A, REUSED FOR 2 TMM0 INSTR.
    TILELOAD TMM3, R10+R11 // SRC1 IS STRIDED LOAD OF B
    TMMAPS TMM0, TMM2, TMM3 // UPDATE LEFT TILE OF C
    TILELOAD TMM3, R10+R11+N // SRC1 LOADED WITH B FROM NEXT RIGHTMOST TILE
    TMMAPS TMM1, TMM2, TMM3 // UPDATE RIGHT TILE OF C
    ADD R8, K // UPDATE POINTERS BY CONSTANTS KNOWN OUTSIDE OF LOOP
    ADD R10, K*R11
    ADD KK, K
    CMP KK, LIMIT
    JNE LOOP
    TILESTORE RSI+RDI, TMM0 // UPDATE THE C MATRIX IN MEMORY
    TILESTORE RSI+RDI+M, TMM1
} // END OF OUTER LOOP
TILERelease // RETURN TILES TO INIT STATE
    
```

FIG. 16



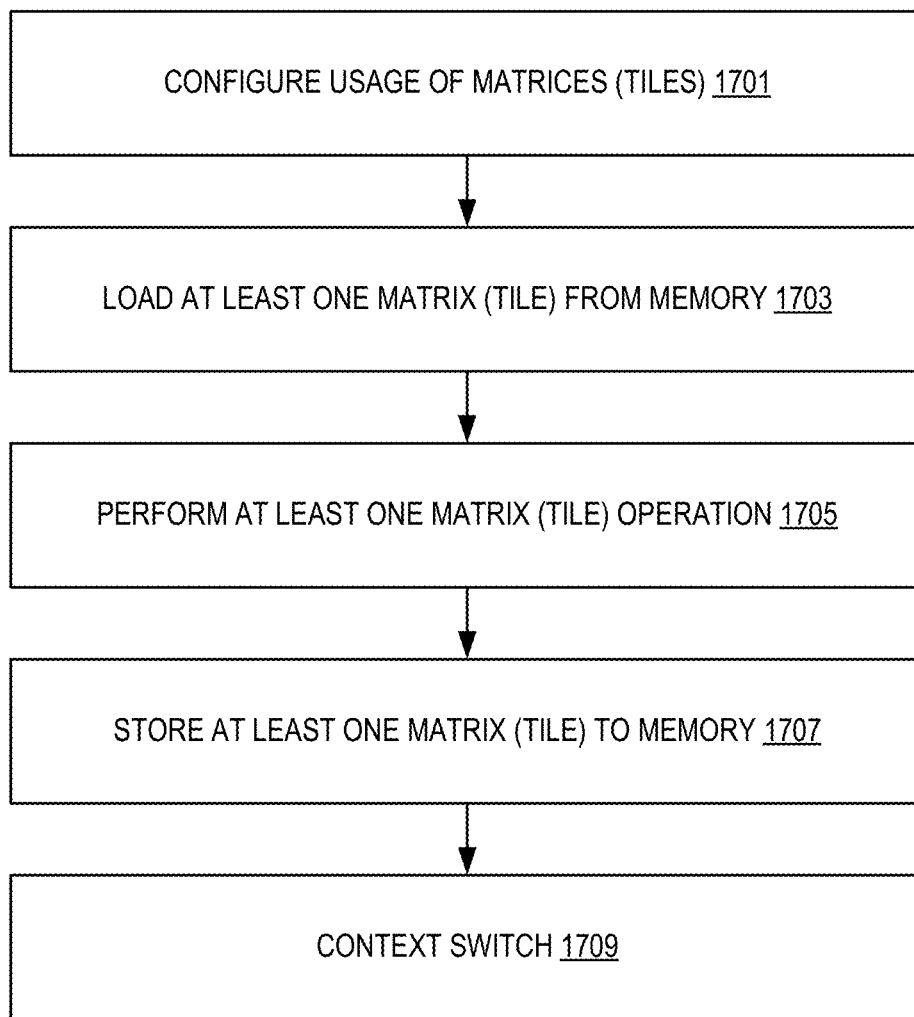

FIG. 17

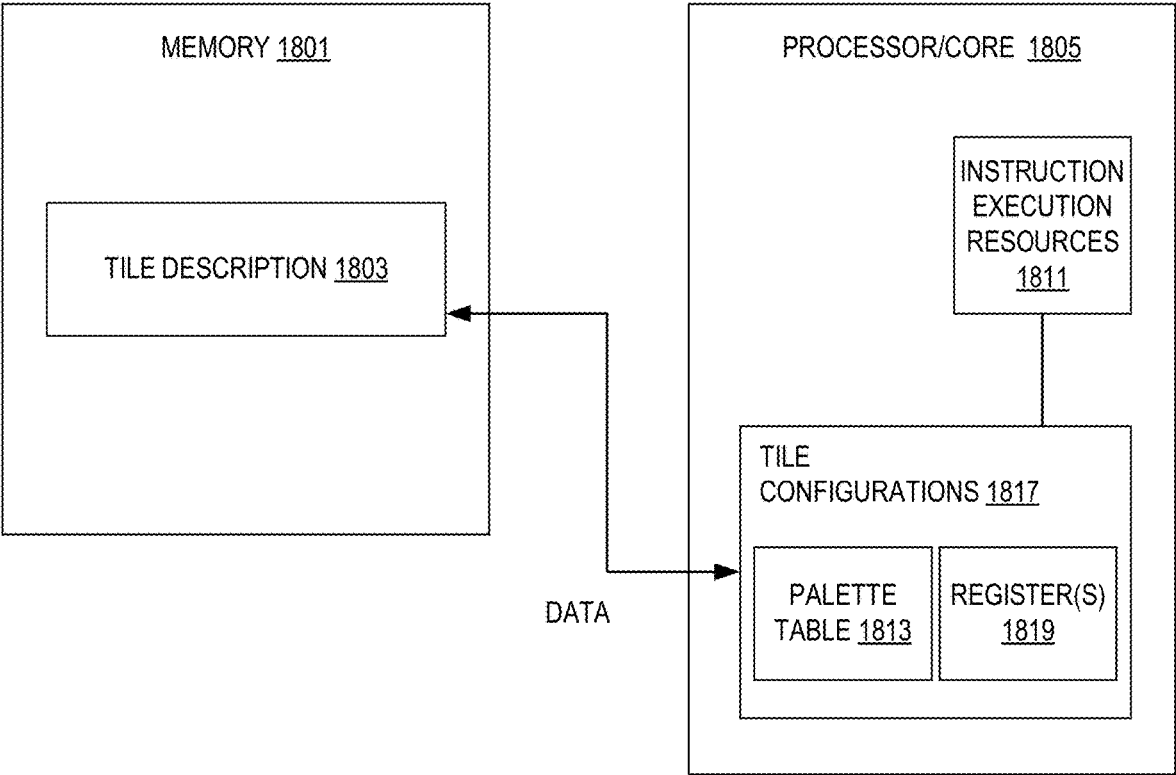

FIG. 18

PALETTE ID <u>1901</u>	STARTM <u>1903</u>
STARTP <u>1905</u>	PAIR INDICATORS <u>1907</u>
0	0
0	0

...

0	0
TMM0 ROWS <u>1913</u>	TMM0 COLUMNS <u>1915</u>
TMM1 ROWS	TMM1 COLUMNS
▪    ▪    ▪	
TMM15 ROWS	TMM15 COLUMNS
0	

**FIG. 19**



FIG. 20(A)

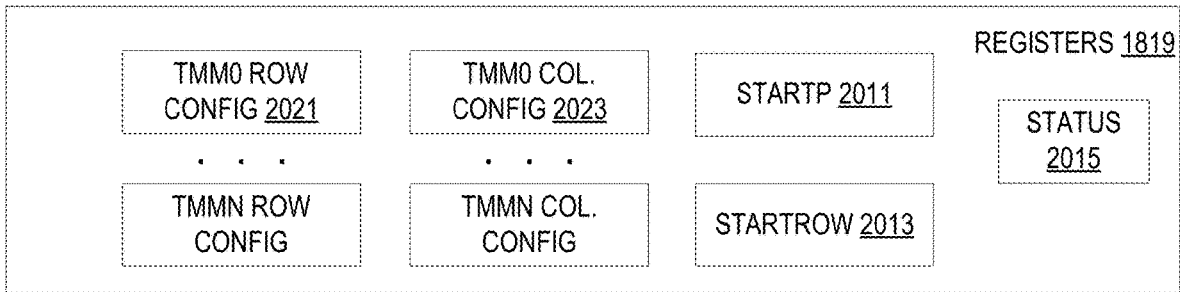

FIG. 20(B)



FIG. 20(C)



FIG. 20(D)

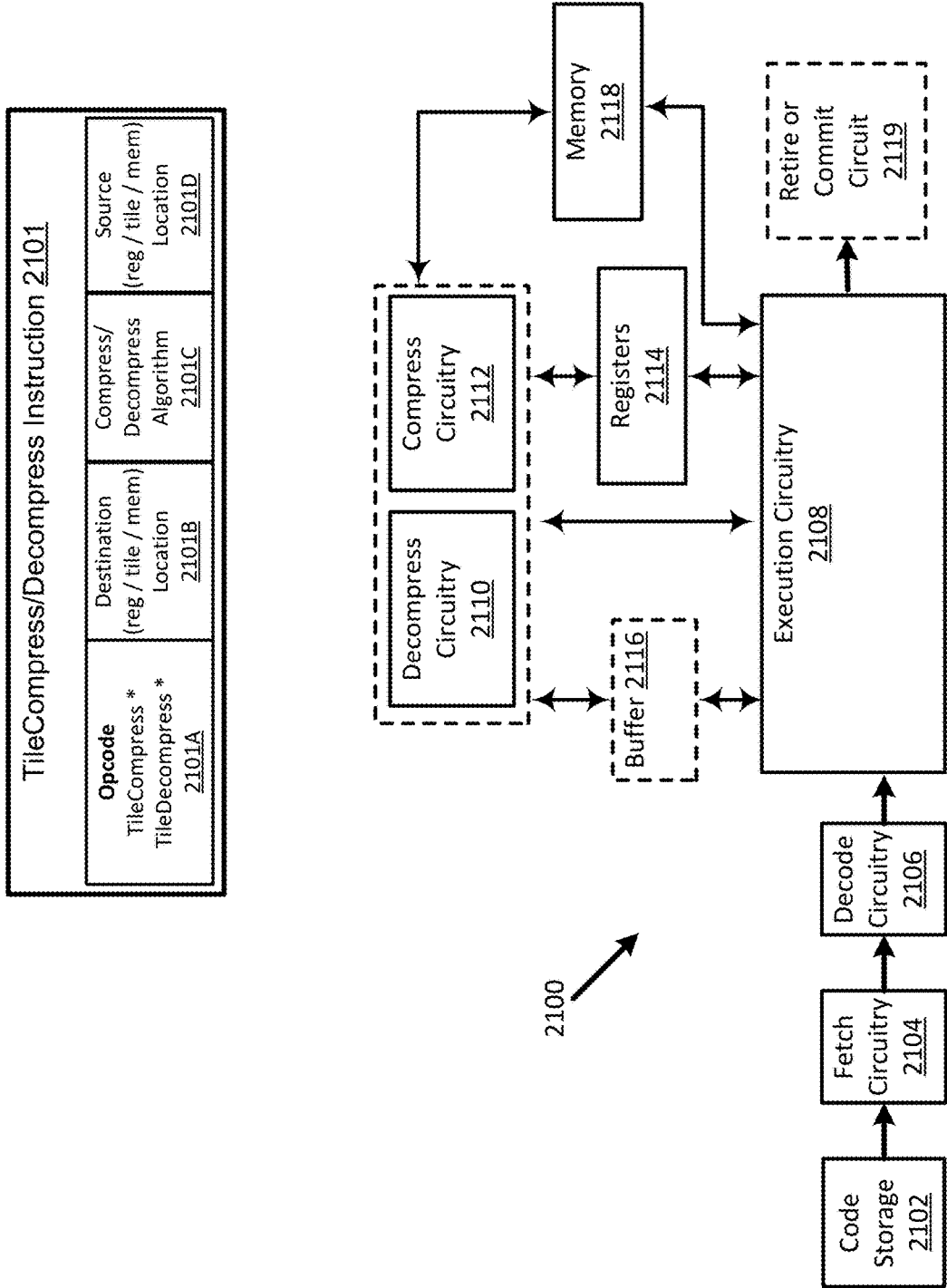

FIG. 21A

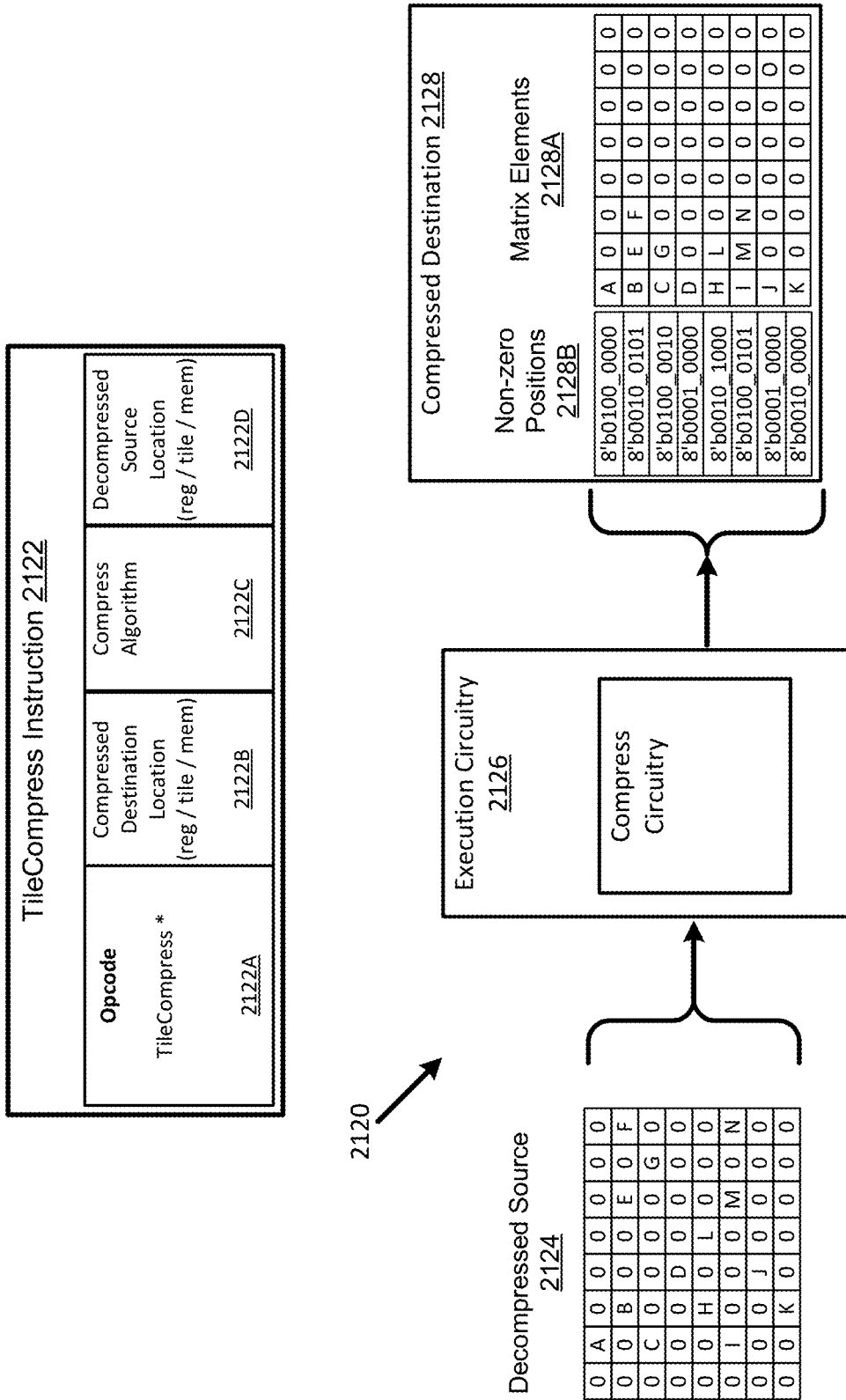

FIG. 21B

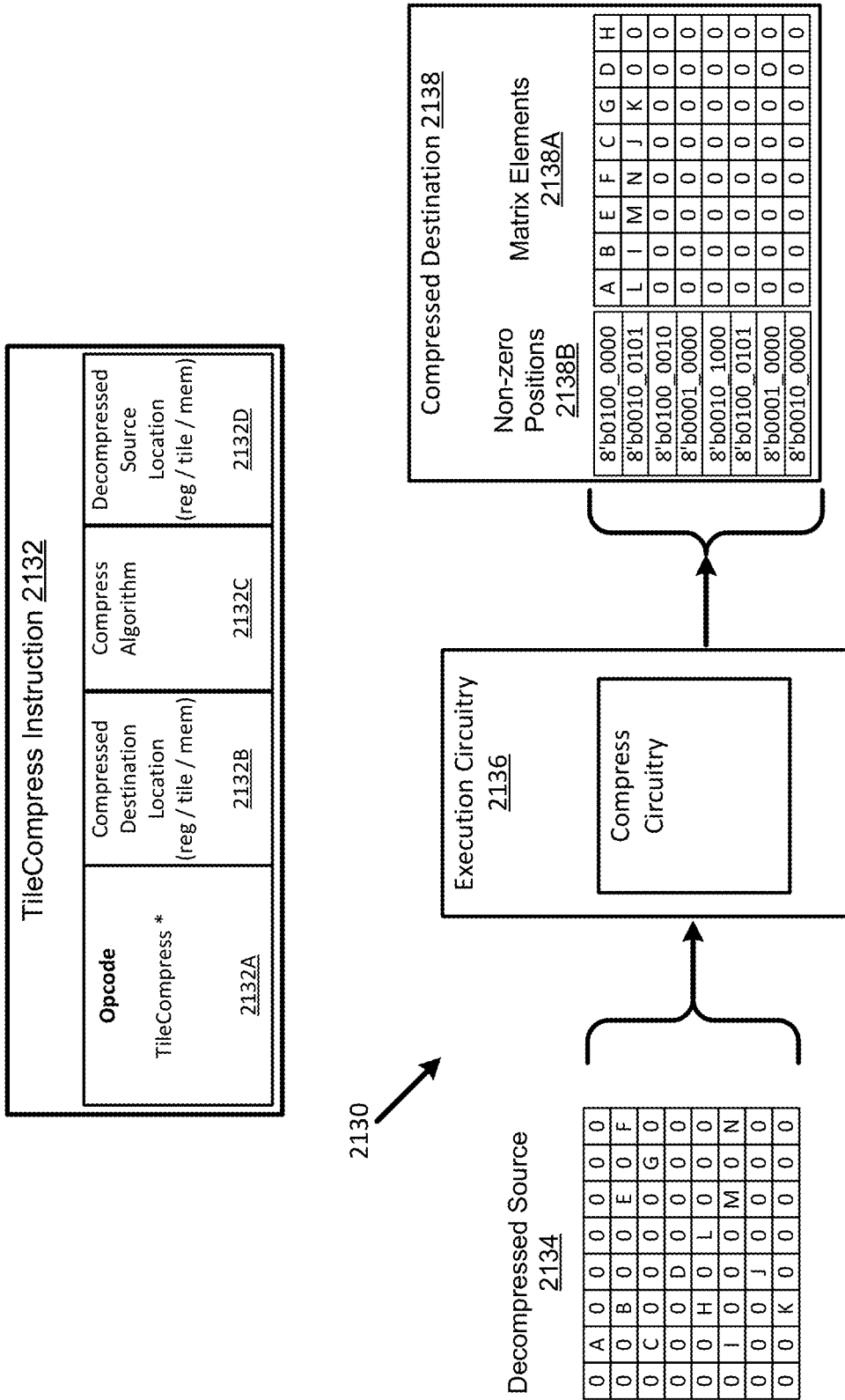

FIG. 21C

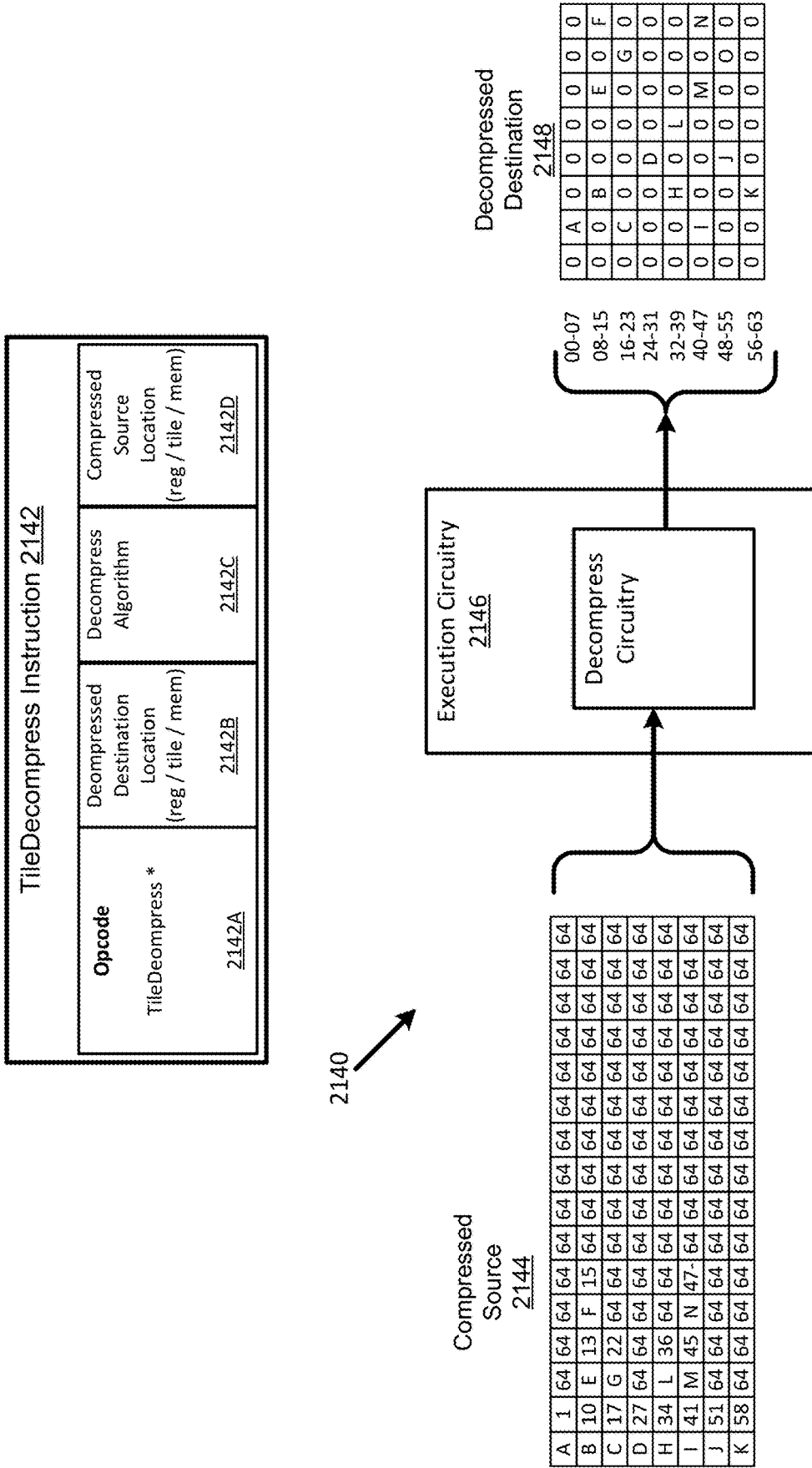

FIG. 21D



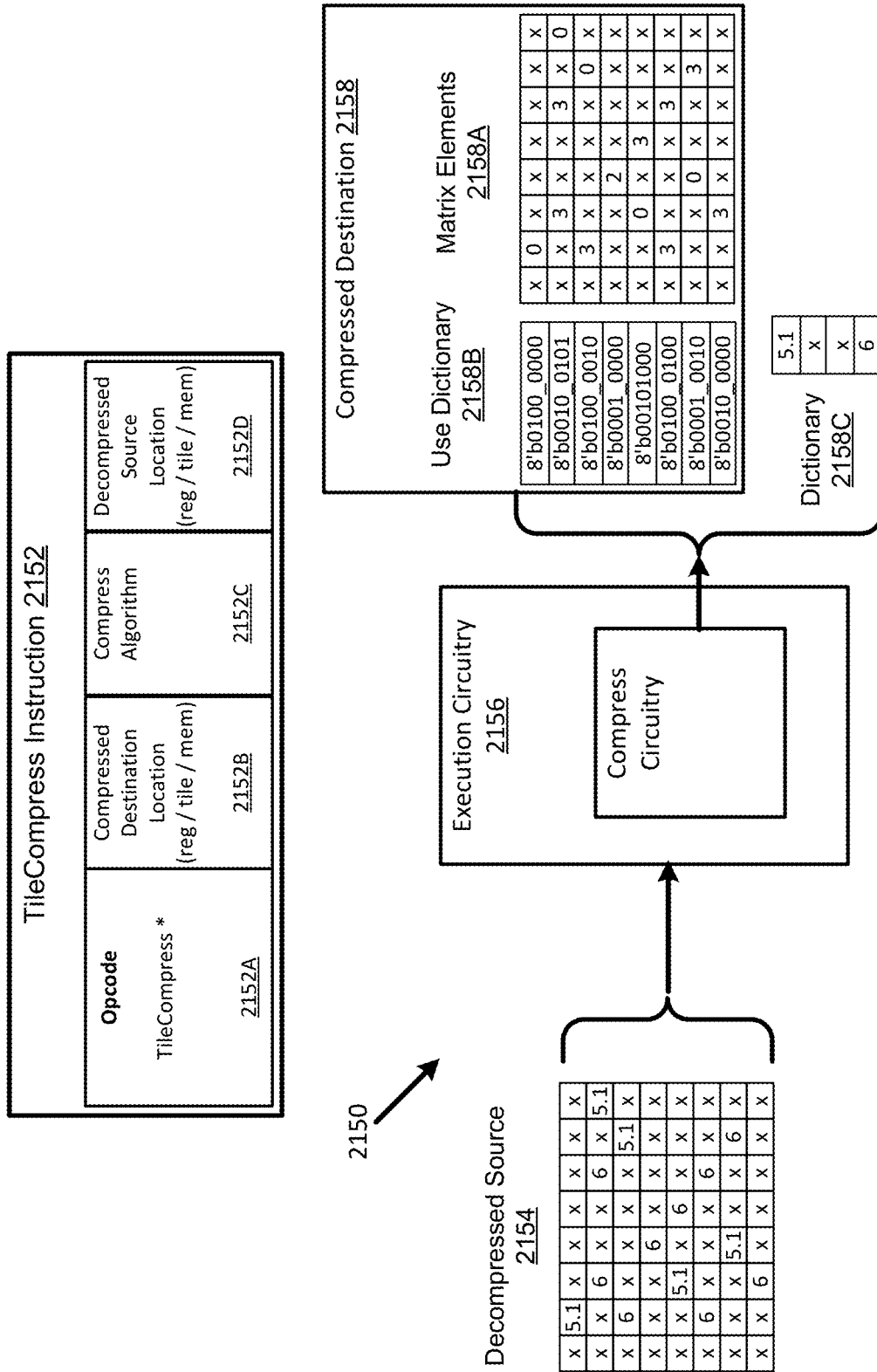

FIG. 21E

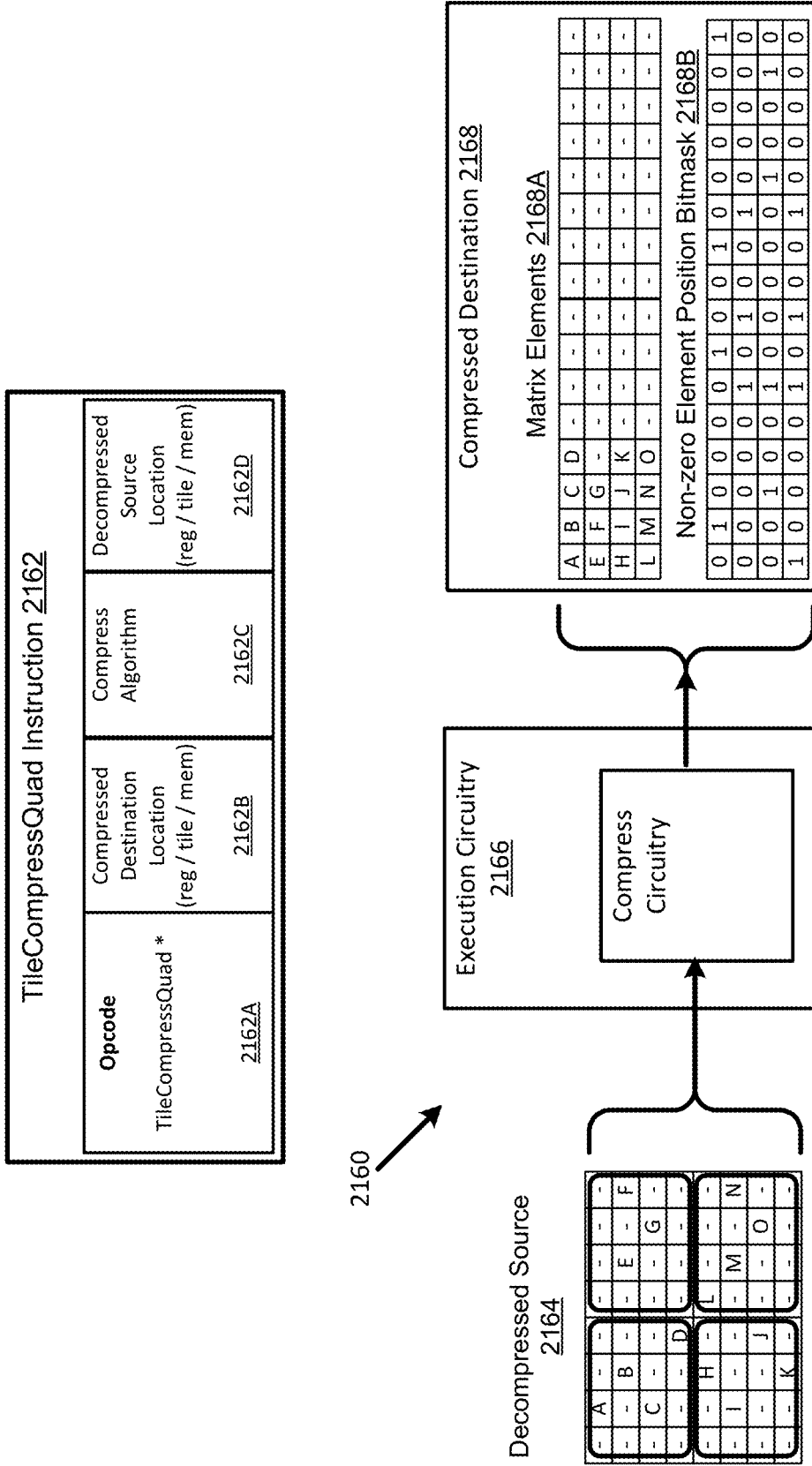

FIG. 21F

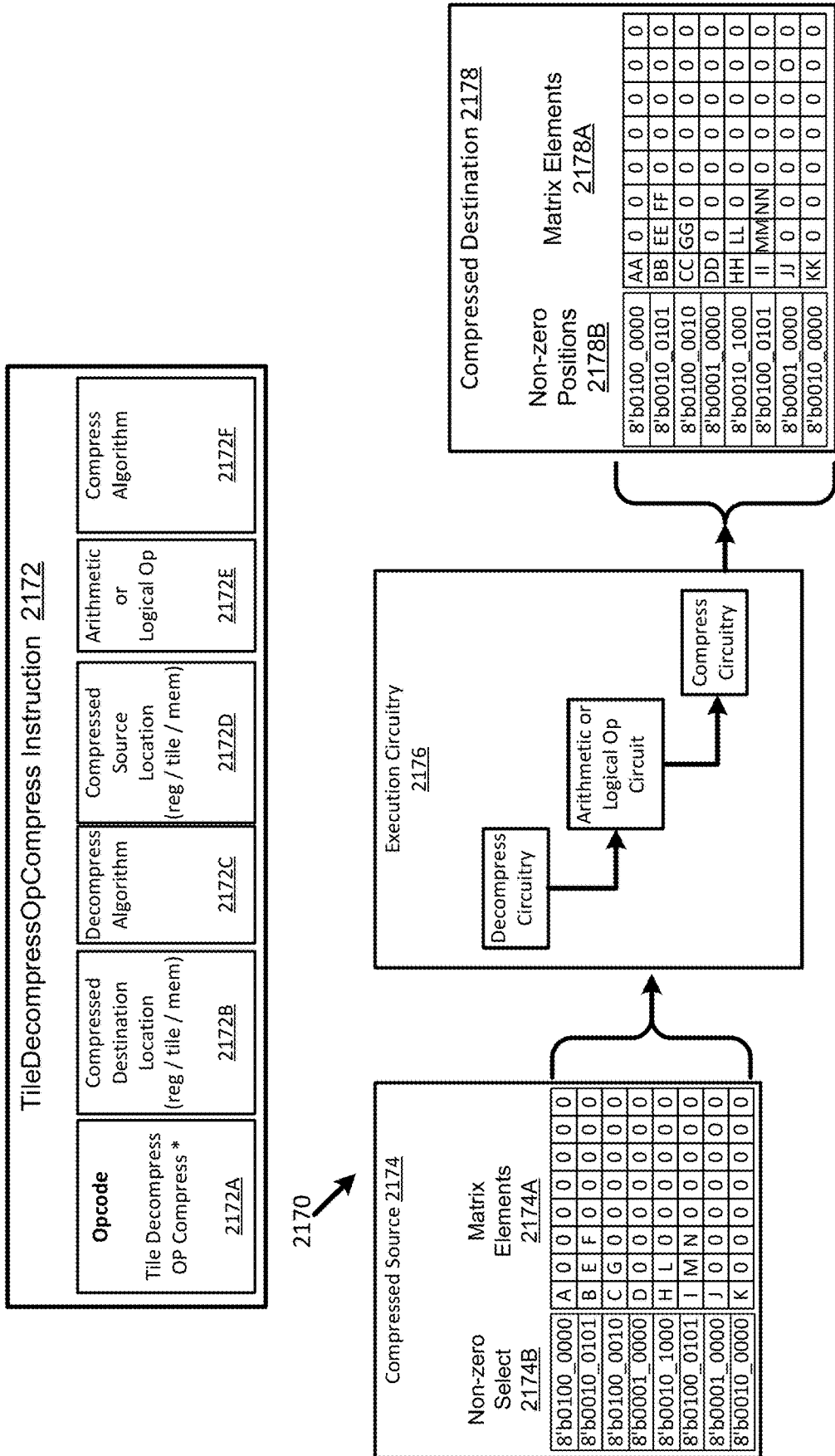

FIG. 21G

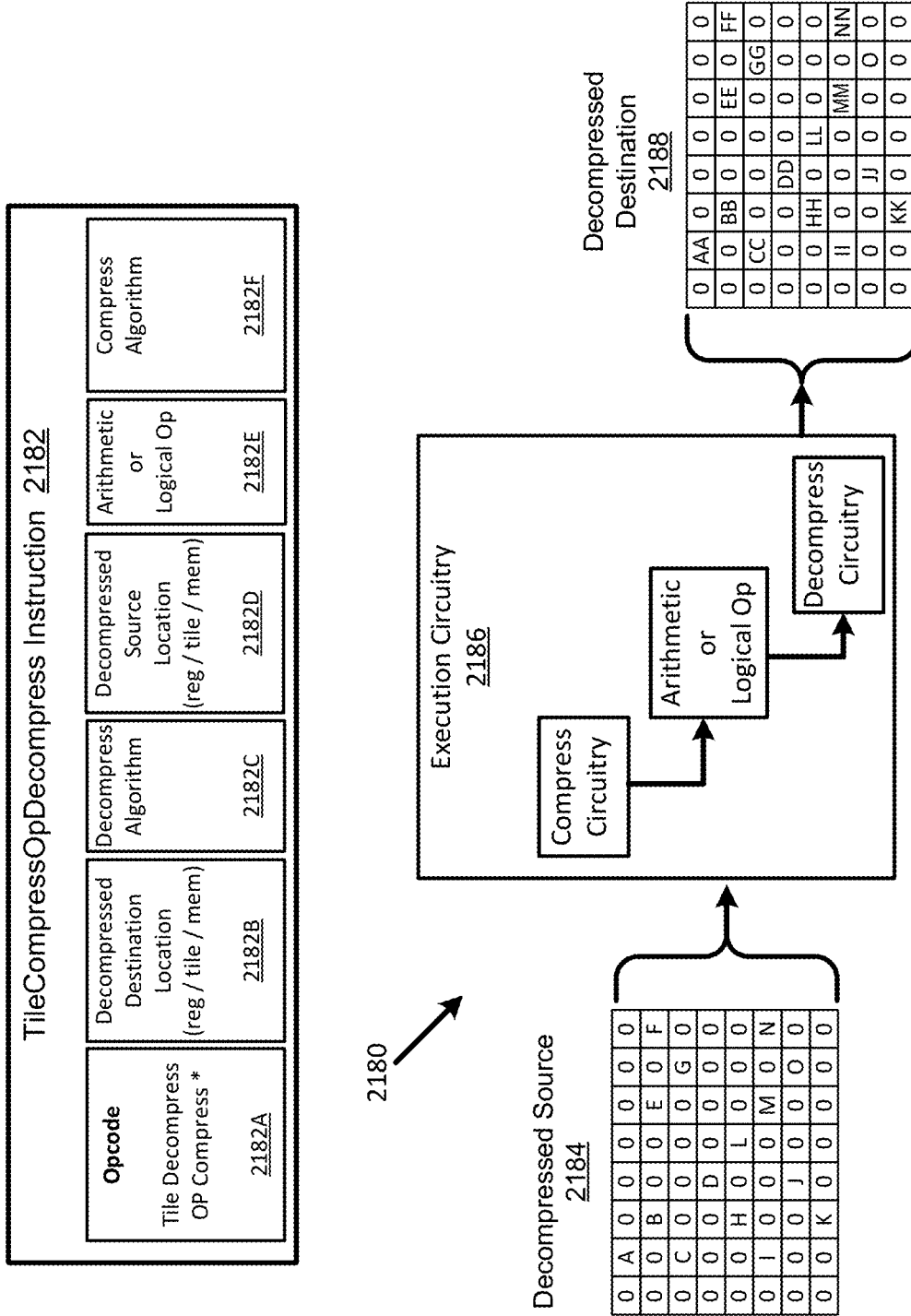

FIG. 21H

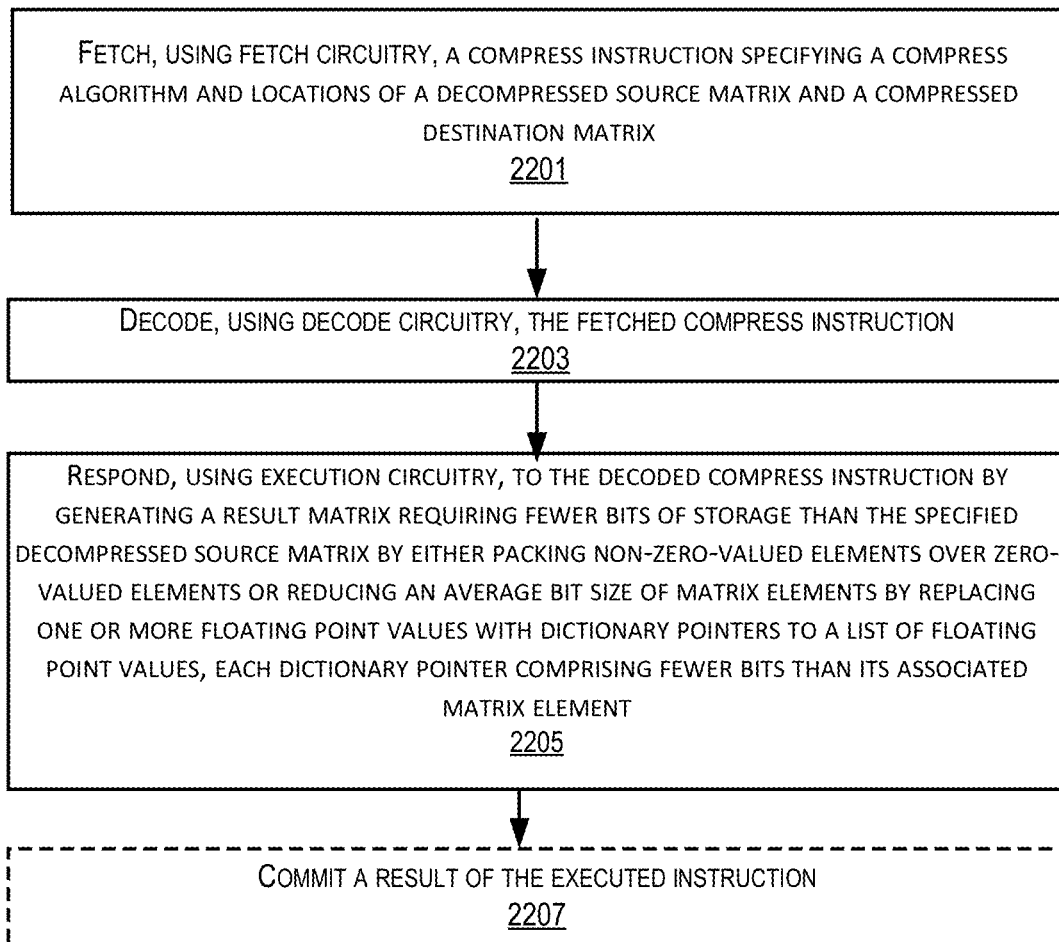
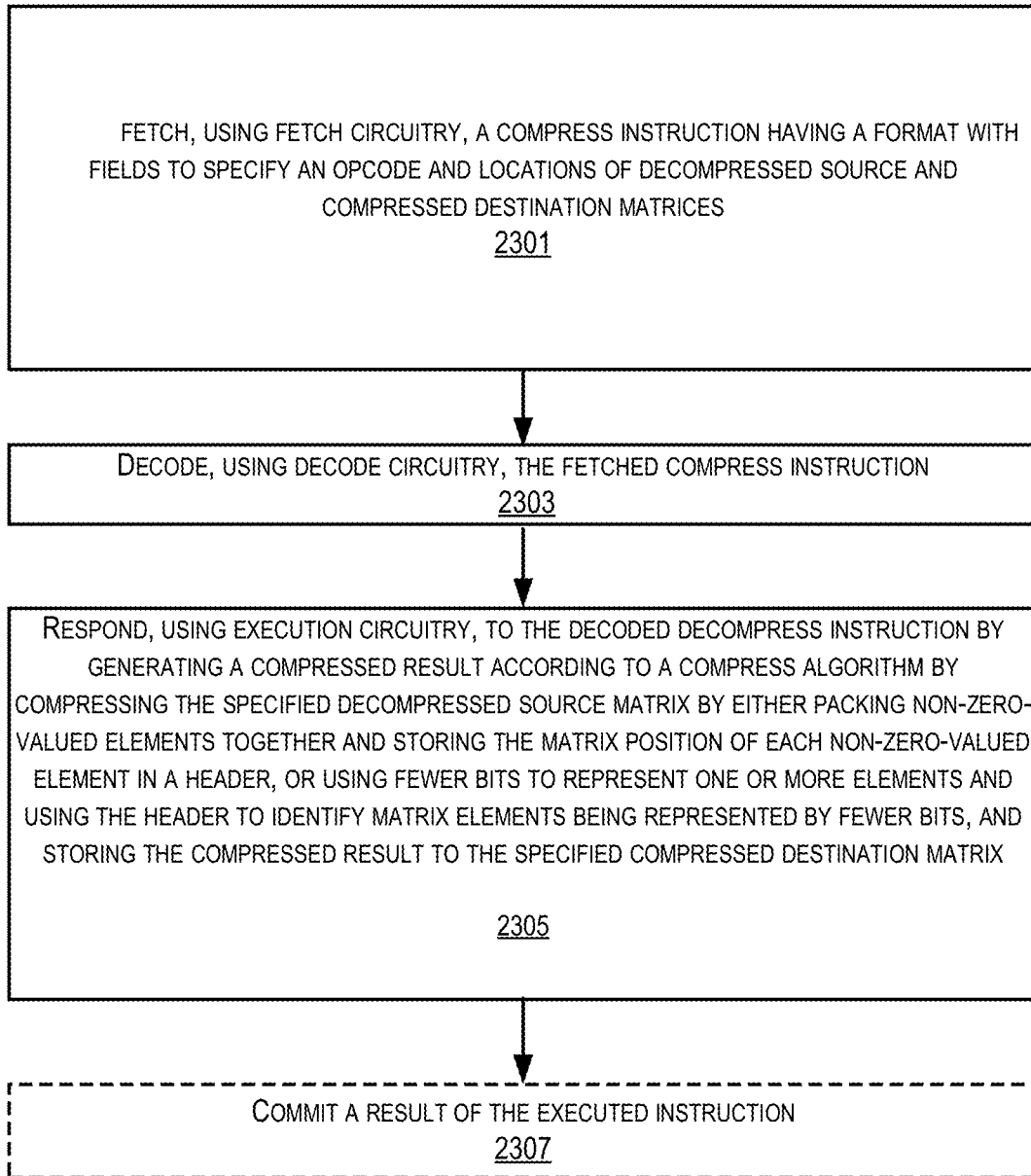

FIG. 22



**FIG. 23**

TileCompress Instruction <u>2402</u>			
<b>Opcode</b> TileDeompress *	Compressed Destination Location (reg / tile / mem)	Compress Algorithm	Decompressed Source Location (reg / tile / mem)
<u>2402A</u>	<u>2402B</u>	<u>2402C</u>	<u>2402D</u>

TileDecompress Instruction <u>2412</u>			
<b>Opcode</b> TileDeompress *	Decompressed Destination Location (reg / tile / mem)	Decompress Algorithm	Compressed Source Location (reg / tile / mem)
<u>2412A</u>	<u>2412B</u>	<u>2412C</u>	<u>2412D</u>

TileDecompressOpCompress Instruction <u>2422</u>					
<b>Opcode</b> Tile Decompress OP Compress *	Compressed Destination Location (reg / tile / mem)	Decompress Algorithm	Compressed Source (reg / tile / mem)	Arithmetic or Logical Op	Compress Algorithm
<u>2422A</u>	<u>2422B</u>	<u>2422C</u>	<u>2422D</u>	<u>2422E</u>	<u>2422F</u>

TileCompressOpDecompress Instruction <u>2432</u>					
<b>Opcode</b> Tile Decompress OP Compress *	Decompressed Destination (reg / tile / mem)	Decompress Algorithm	Decompressed Source (reg / tile / mem)	Arithmetic or Logical Op	Compress Algorithm
<u>2432A</u>	<u>2432B</u>	<u>2432C</u>	<u>2432D</u>	<u>2432E</u>	<u>2432F</u>

FIG. 24

FIG. 25A

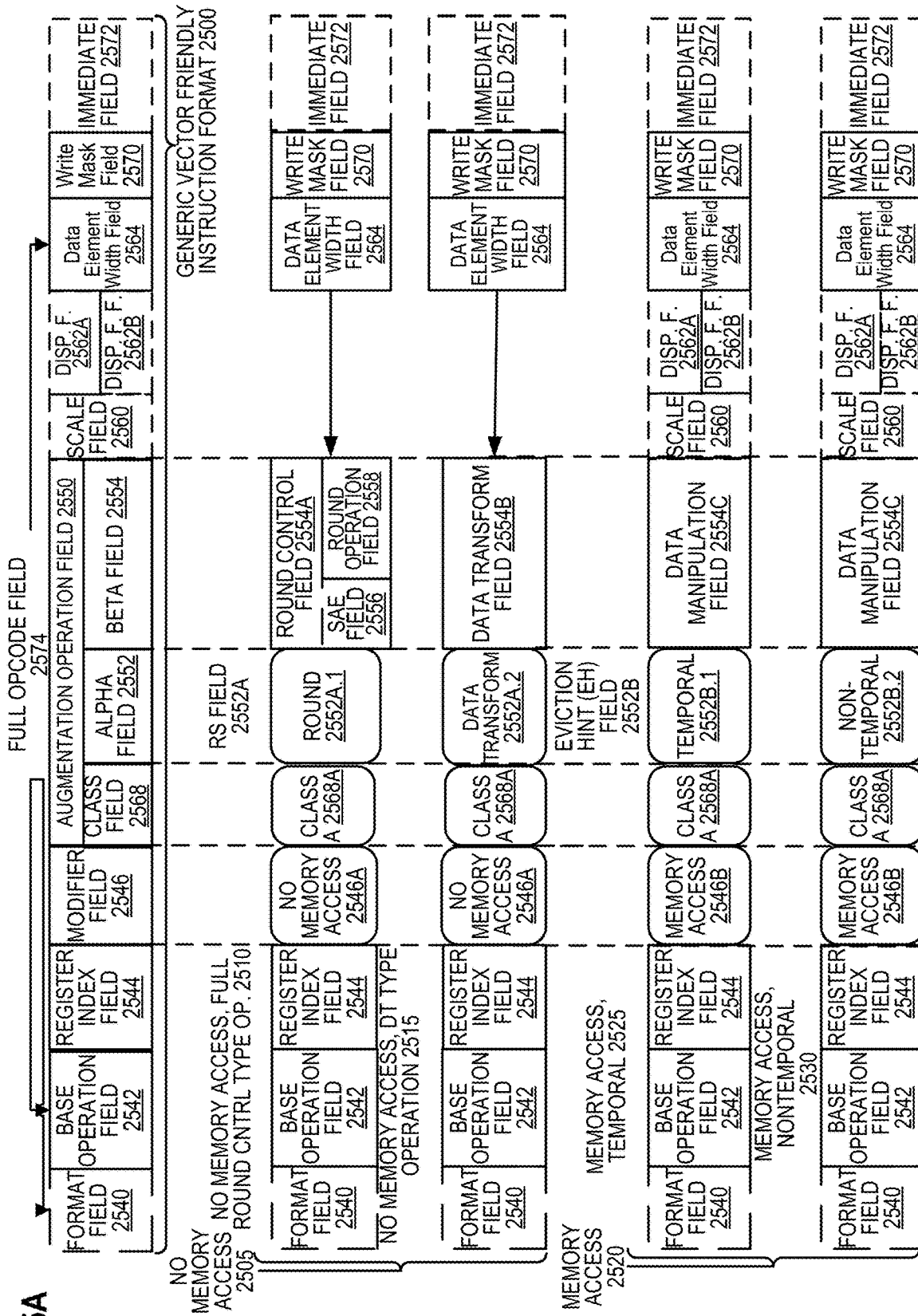
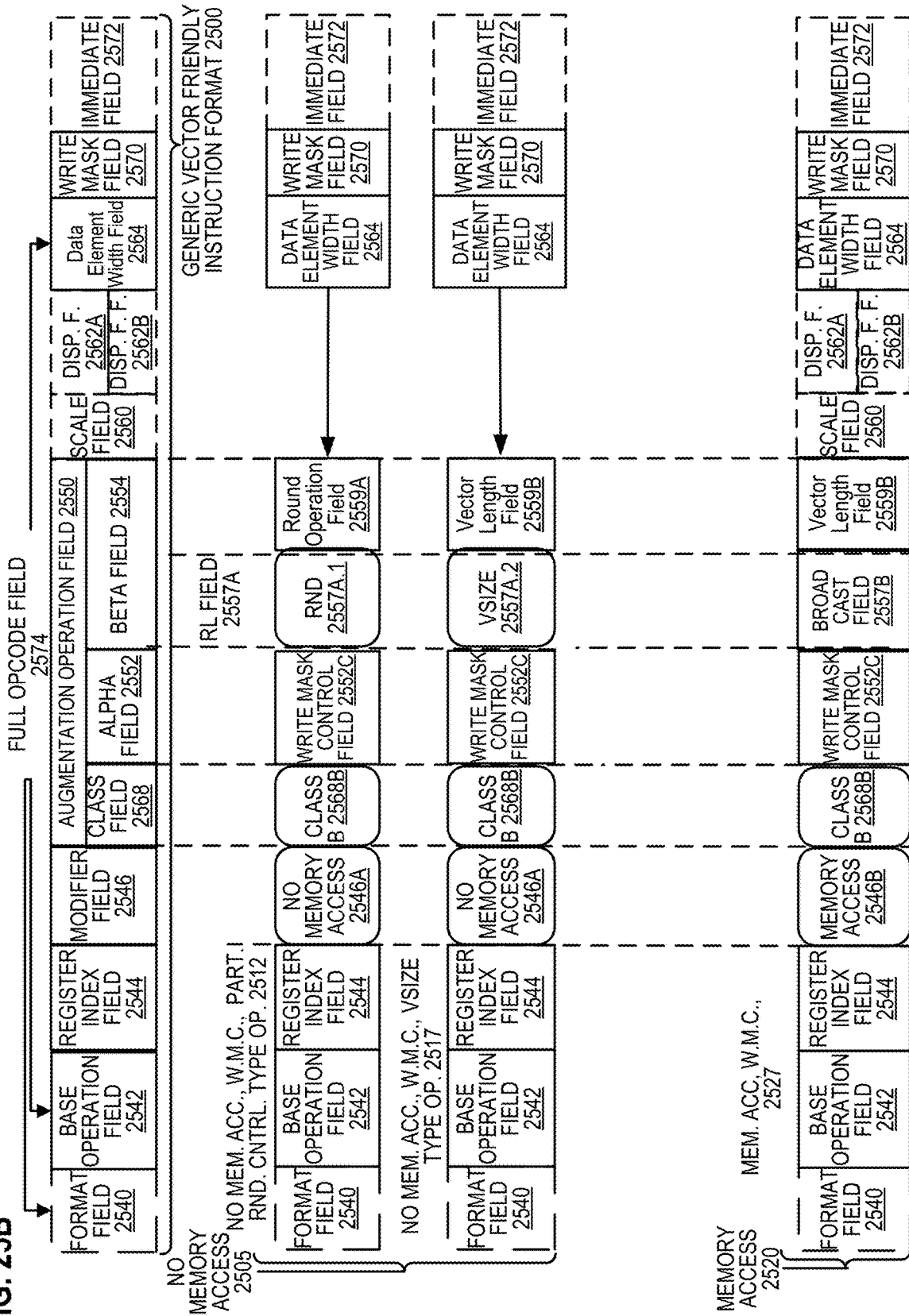
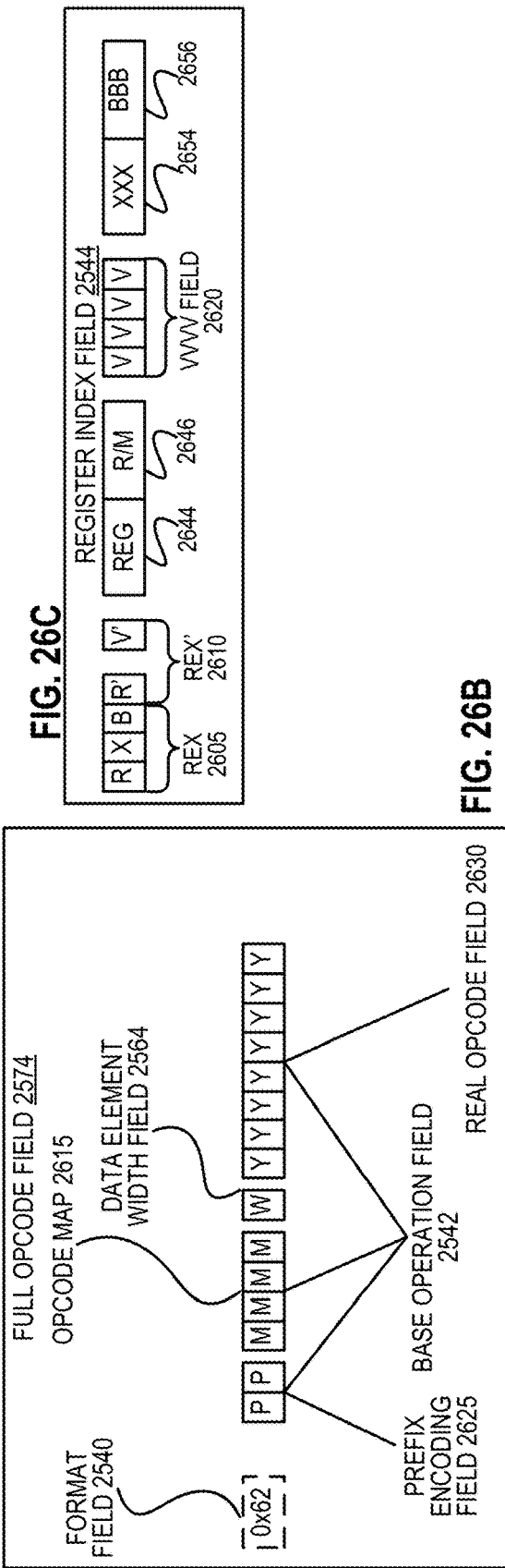
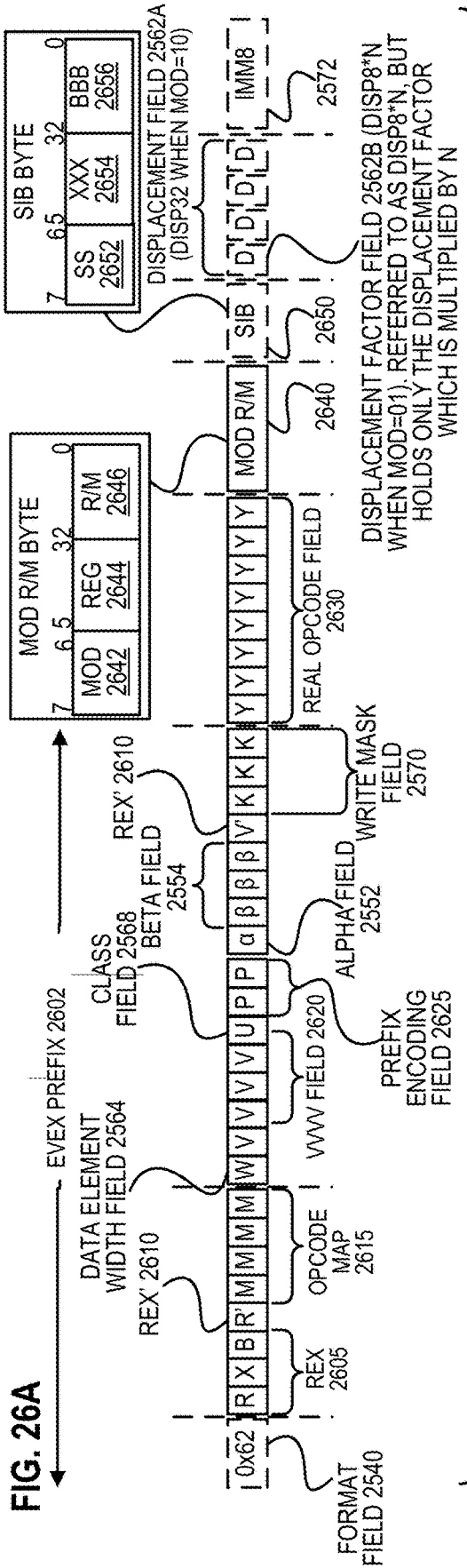



FIG. 25B





**FIG. 26B**

FIG. 26D

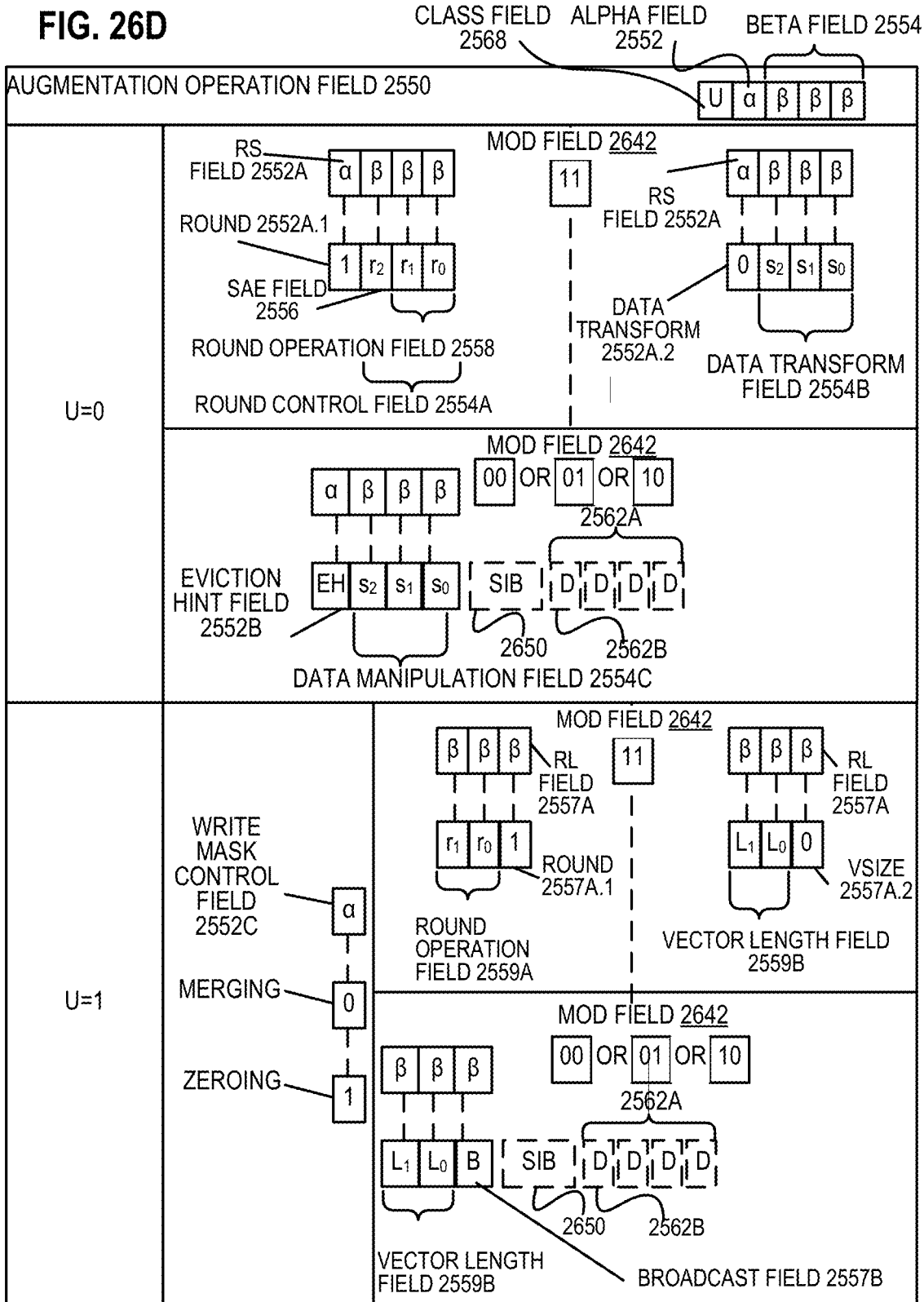
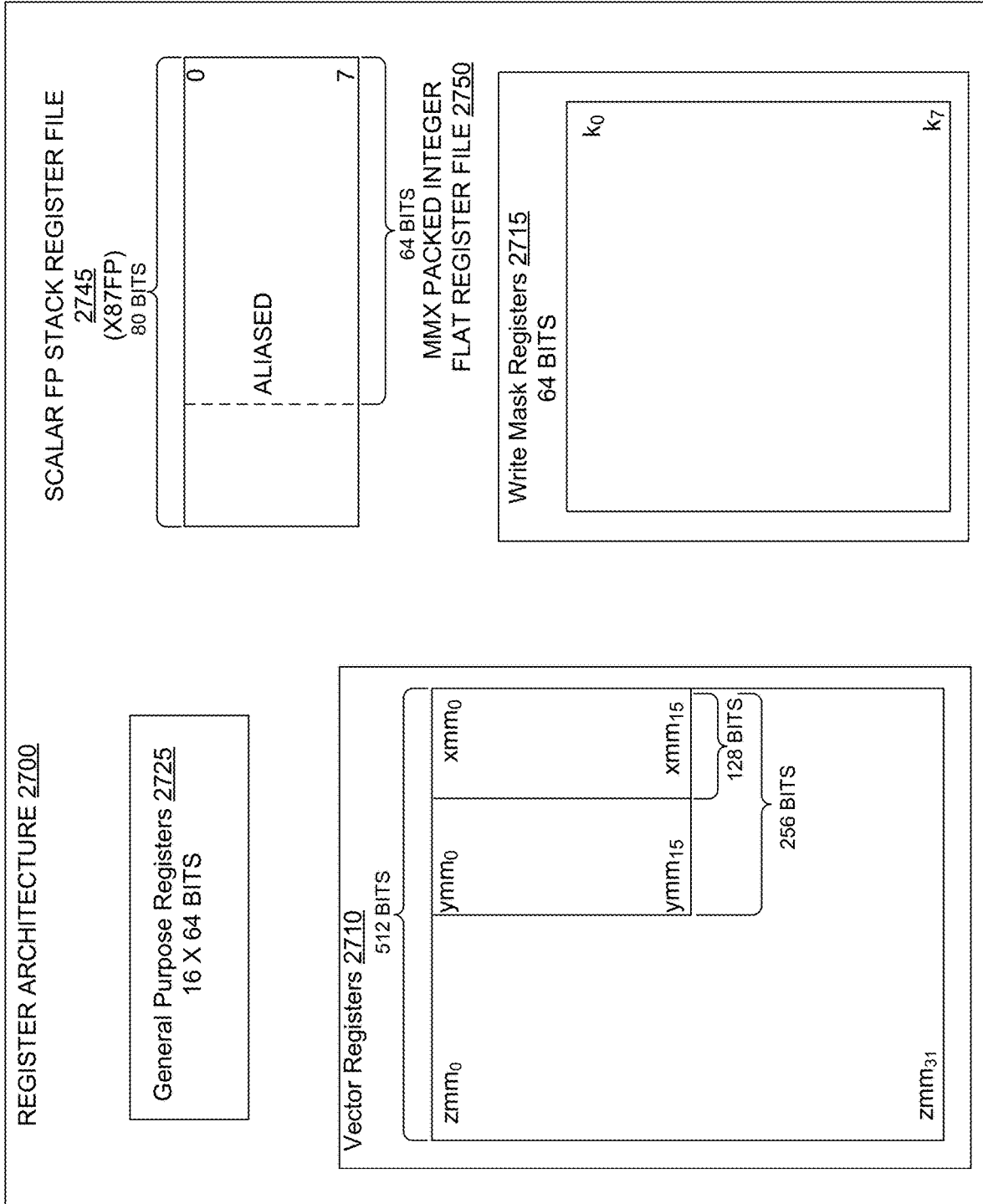

FIG. 27



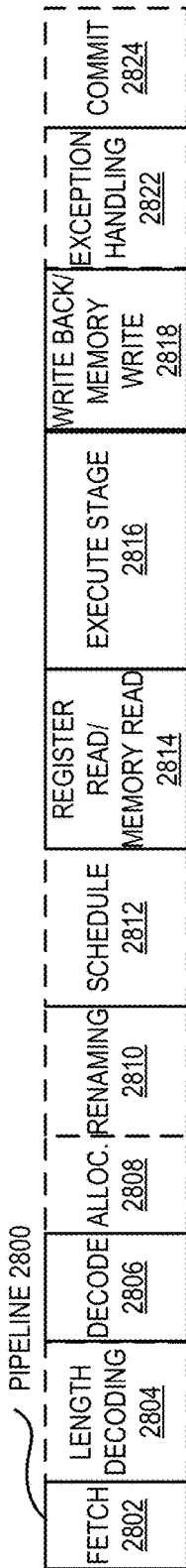

FIG. 28A

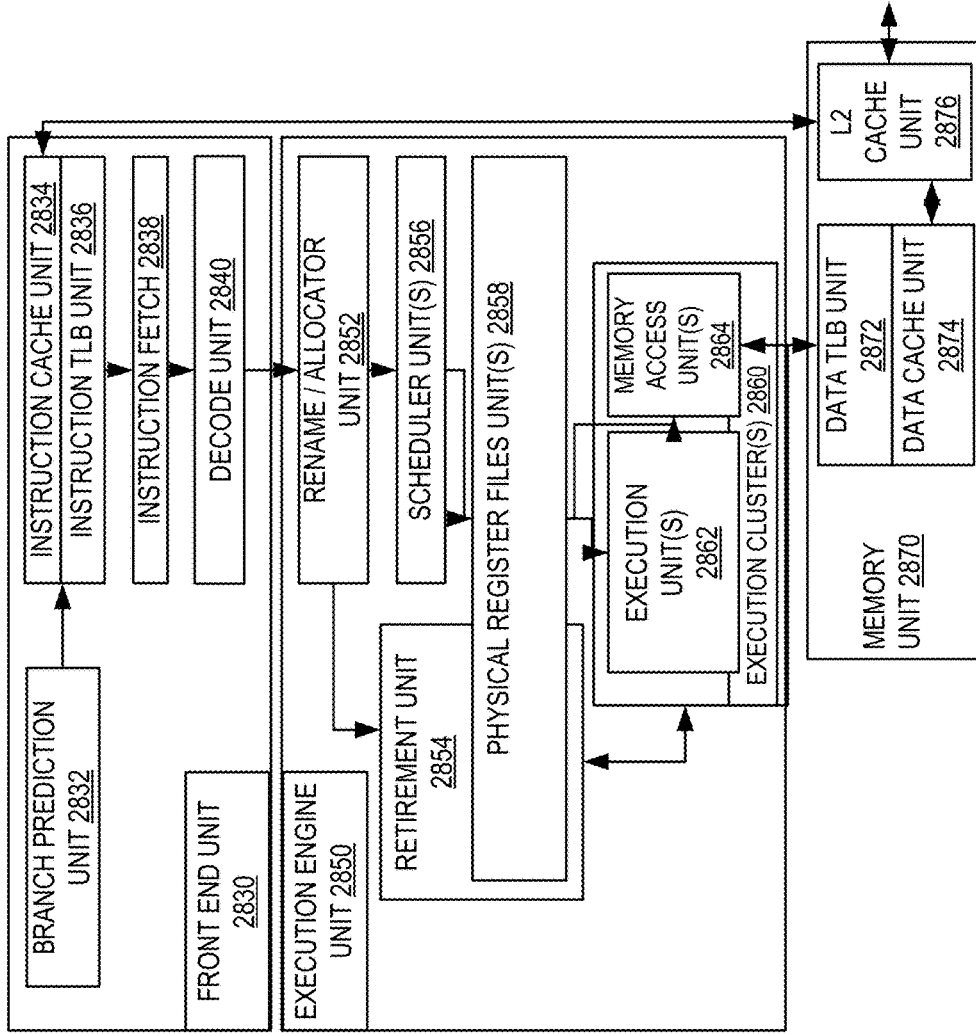

FIG. 28B

FIG. 29A

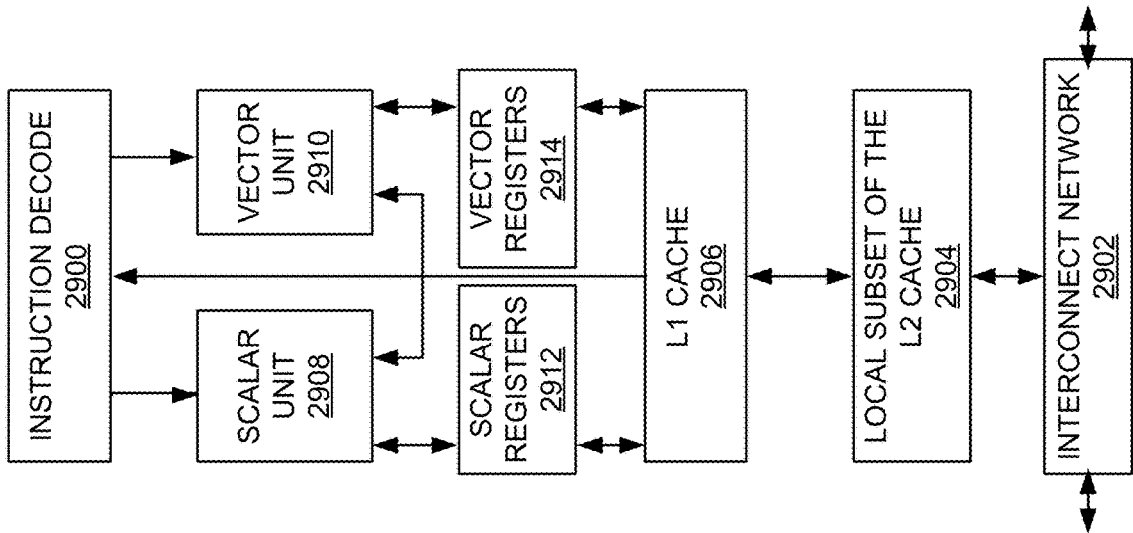
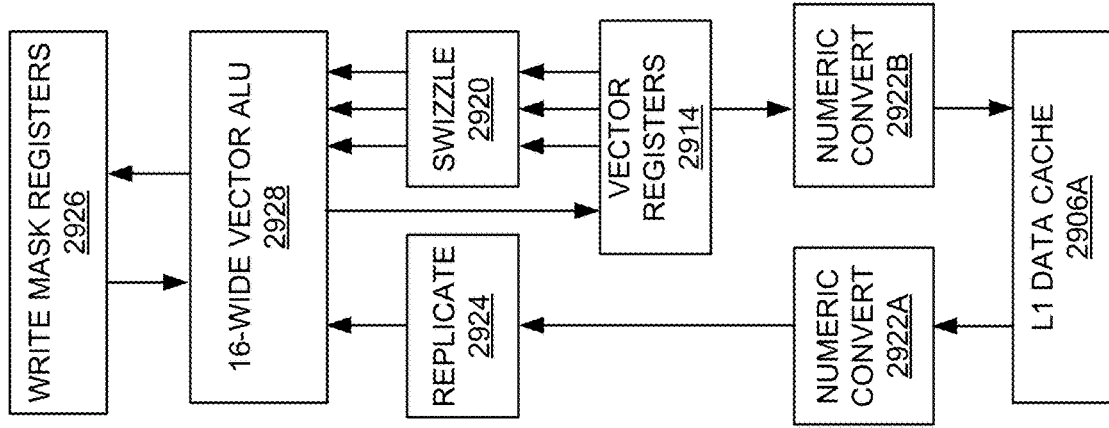

FIG. 29B



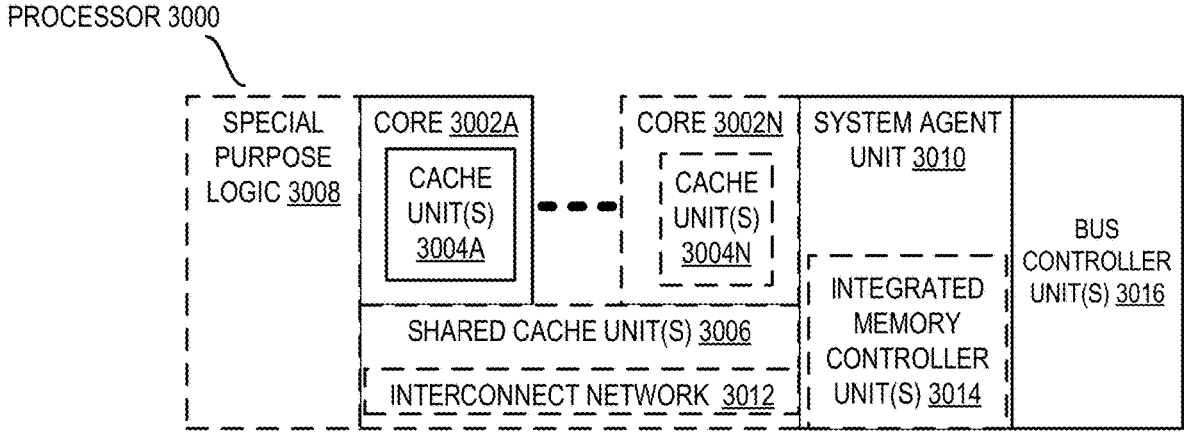

FIG. 30

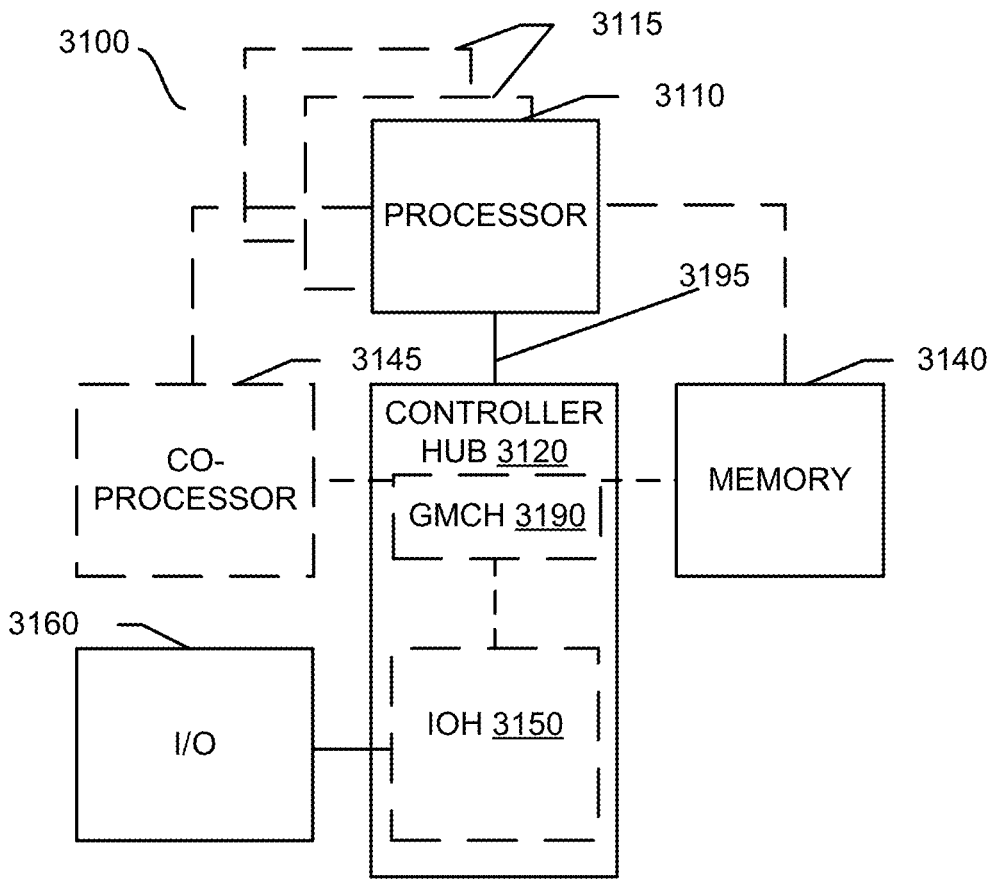

FIG. 31



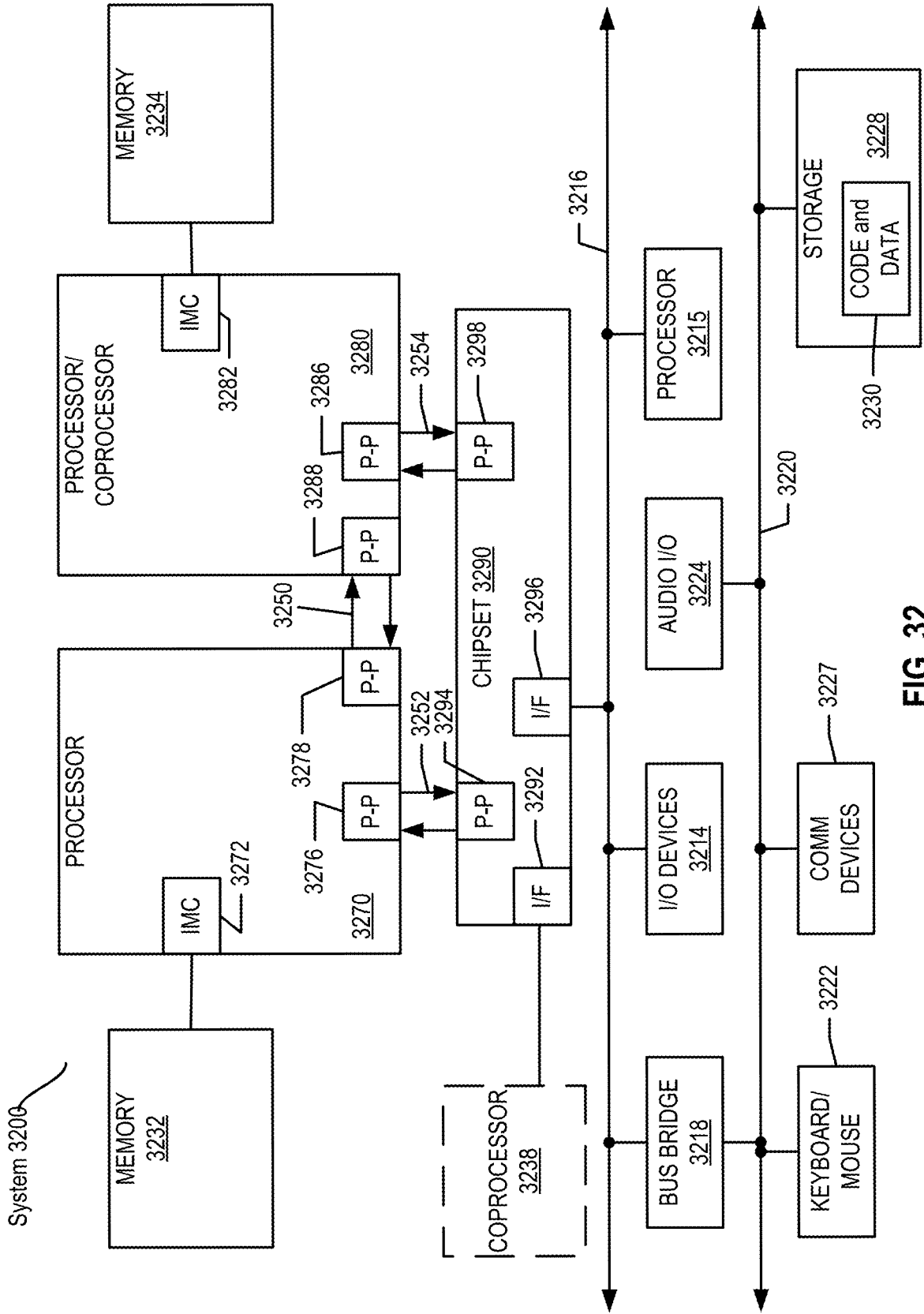

FIG. 32

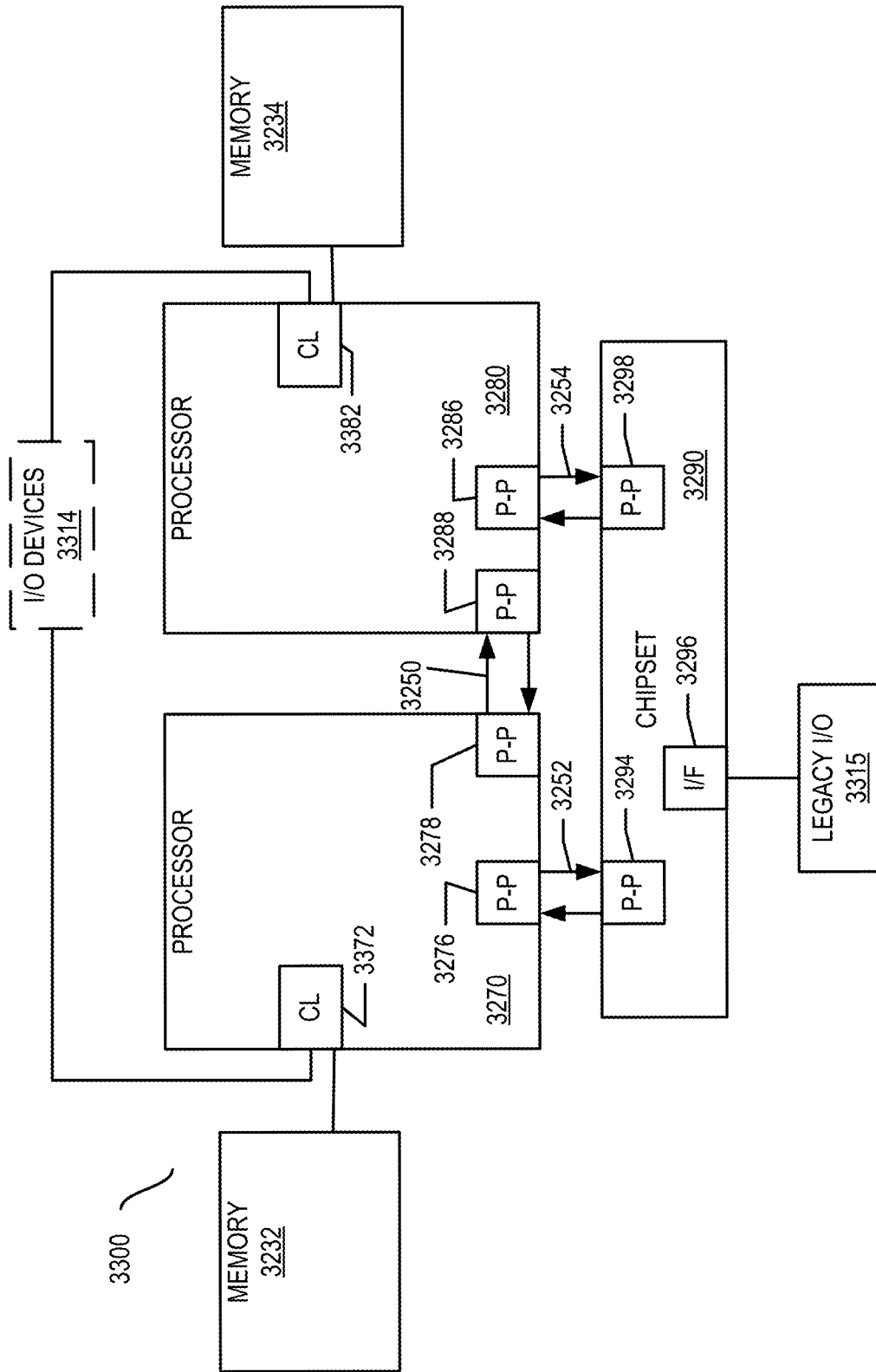

FIG. 33

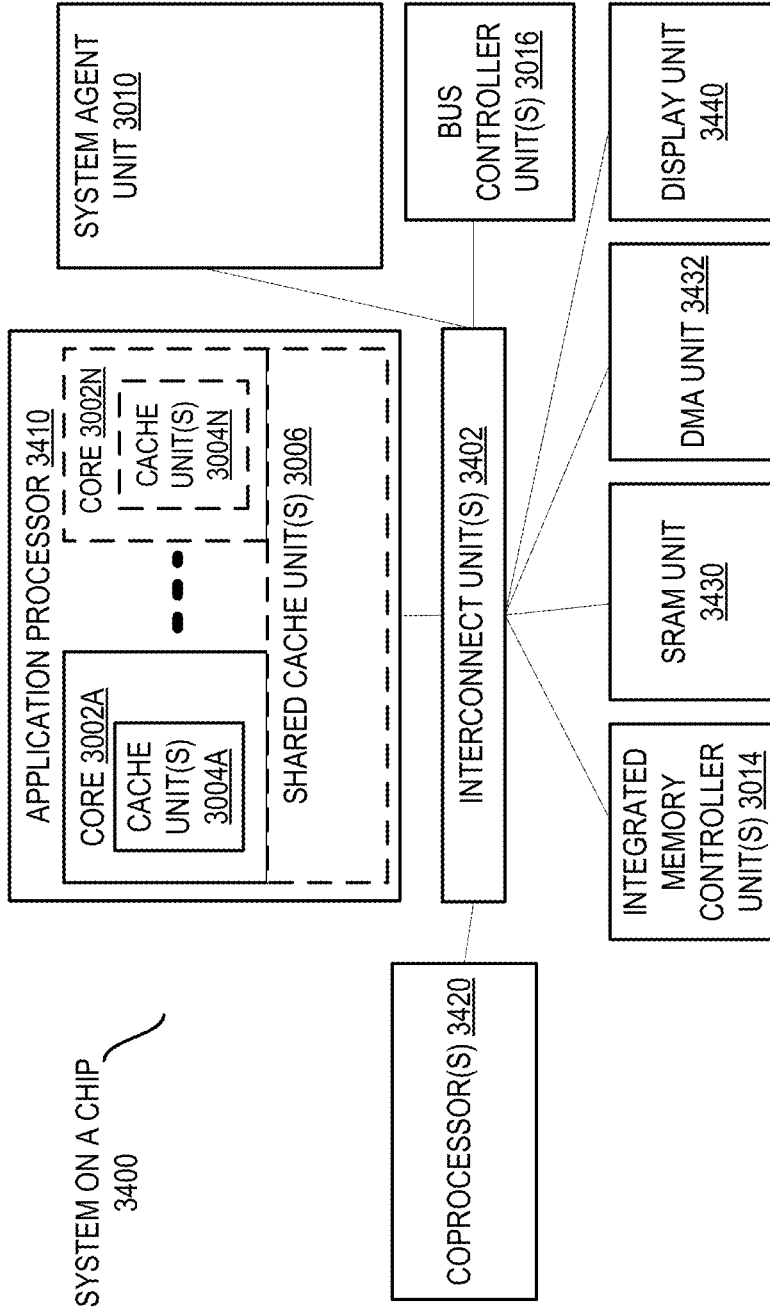

FIG. 34

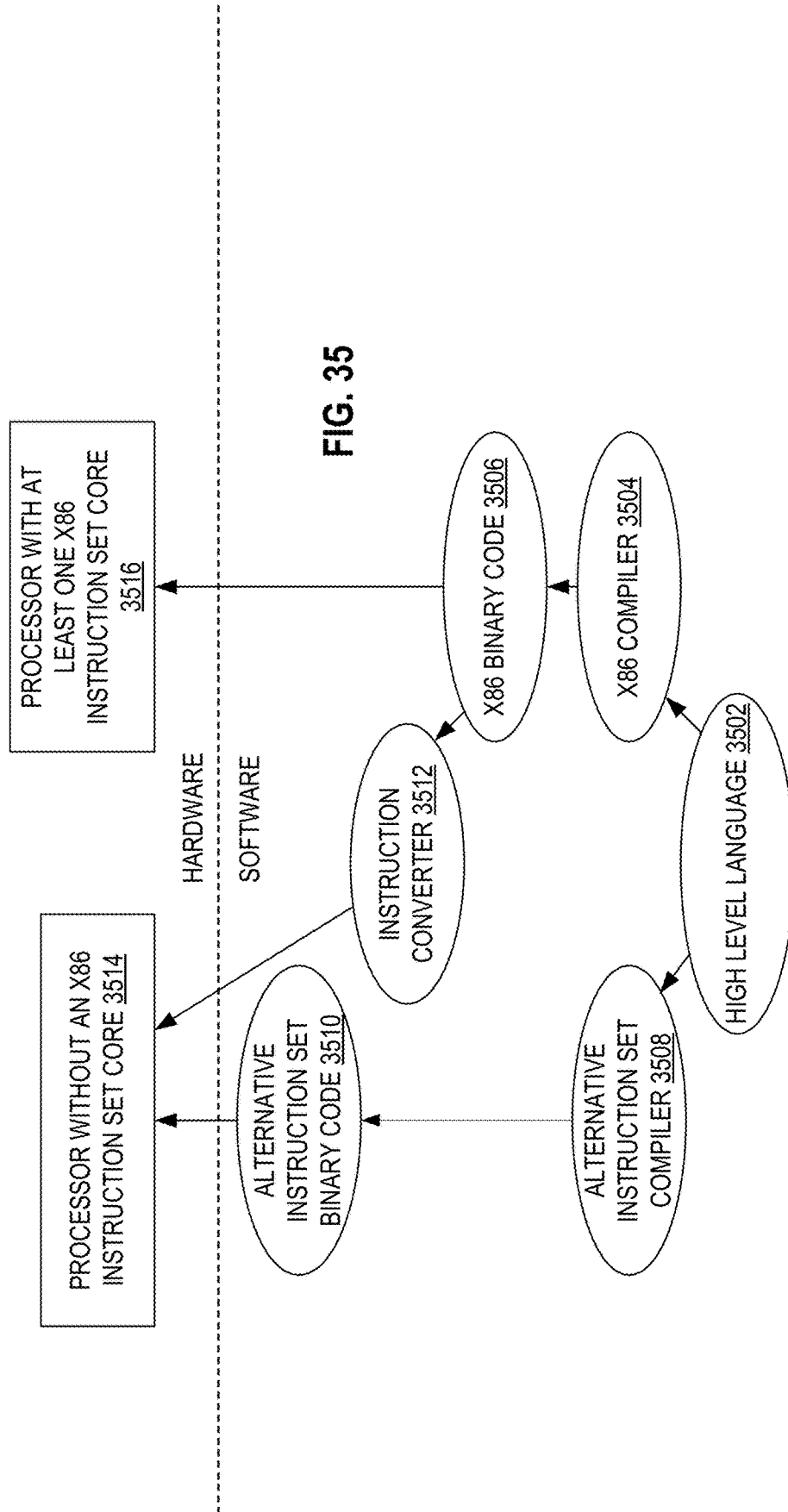

FIG. 35

## SYSTEMS AND METHODS FOR PERFORMING MATRIX COMPRESS AND DECOMPRESS INSTRUCTIONS

### CROSS-REFERENCE TO RELATED APPLICATIONS

[0001] The present patent application is a continuation application claiming priority from U.S. patent application Ser. No. 16/934,003 filed Jul. 20, 2020, now U.S. Pat. No. 11,249,761, which is a continuation application claiming priority from U.S. patent application Ser. No. 16/144,902 filed Sep. 27, 2018, now U.S. Pat. No. 10,719,323, each of which is incorporated herein by reference in its entirety.

### FIELD OF INVENTION

[0002] The field of invention relates generally to computer processor architecture, and, more specifically, to systems and methods for performing matrix compress and decompress instructions.

### BACKGROUND

[0003] Matrices are increasingly important in many computing tasks such as machine learning and other bulk data processing. Deep Learning is a class of machine learning algorithms. Deep learning architectures, such as deep neural networks, have been applied to fields including computer vision, speech recognition, natural language processing, audio recognition, social network filtering, machine translation, bioinformatics and drug design.

[0004] Inference and training, two tools used for deep learning, are tending towards low precision arithmetic. Maximizing throughput of deep learning algorithms and computations may assist in meeting the needs of deep learning processors, for example, those performing deep learning in a data center.

[0005] General Matrix Multiply (GEMM) is a common algorithm in machine learning, and also in linear algebra, statistics, and many other domains. Convolution is also commonly applied in machine learning. Instructions for performing matrix compress and decompress operations are useful in performing convolution and GEMM algorithms in a machine learning context.

### BRIEF DESCRIPTION OF THE DRAWINGS

[0006] The present invention is illustrated by way of example and not limitation in the figures of the accompanying drawings, in which like references indicate similar elements and in which:

[0007] FIG. 1A illustrates an embodiment of configured tiles;

[0008] FIG. 1B illustrates an embodiment of configured tiles;

[0009] FIG. 2 illustrates several examples of matrix storage;

[0010] FIG. 3 illustrates an embodiment of a system utilizing a matrix (tile) operations accelerator;

[0011] FIGS. 4 and 5 show different embodiments of how memory is shared using a matrix operations accelerator;

[0012] FIG. 6 illustrates an embodiment of matrix multiply accumulate operation using tiles (“TMMA”);

[0013] FIG. 7 illustrates an embodiment of a subset of the execution of an iteration of a chained fused multiply accumulate instruction;

[0014] FIG. 8 illustrates an embodiment of a subset of the execution of an iteration of a chained fused multiply accumulate instruction;

[0015] FIG. 9 illustrates an embodiment of a subset of the execution of an iteration of a chained fused multiply accumulate instruction;

[0016] FIG. 10 illustrates an embodiment of a subset of the execution of an iteration of chained fused multiply accumulate instruction;

[0017] FIG. 11 illustrates power-of-two sized SIMD implementations wherein the accumulators use input sizes that are larger than the inputs to the multipliers according to an embodiment;

[0018] FIG. 12 illustrates an embodiment of a system utilizing matrix operations circuitry;

[0019] FIG. 13 illustrates an embodiment of a processor core pipeline supporting matrix operations using tiles;

[0020] FIG. 14 illustrates an embodiment of a processor core pipeline supporting matrix operations using tiles;

[0021] FIG. 15 illustrates an example of a matrix expressed in row major format and column major format;

[0022] FIG. 16 illustrates an example of usage of matrices (tiles);

[0023] FIG. 17 illustrates an embodiment a method of usage of matrices (tiles);

[0024] FIG. 18 illustrates support for configuration of the usage of tiles according to an embodiment;

[0025] FIG. 19 illustrates an embodiment of a description of the matrices (tiles) to be supported;

[0026] FIGS. 20(A)-(D) illustrate examples of register(s);

[0027] FIG. 21A illustrates a block diagram of hardware processing components to use to execute TileCompress/Decompress instructions, according to some embodiments;

[0028] FIG. 21B illustrates an exemplary execution of a TileCompress instruction according to some embodiments;

[0029] FIG. 21C illustrates an exemplary execution of a TileCompress instruction according to some embodiments;

[0030] FIG. 21D illustrates an exemplary execution of a TileDecompress instruction according to some embodiments;

[0031] FIG. 21E illustrates an exemplary execution of a TileCompress instruction according to some embodiments;

[0032] FIG. 21F illustrates an exemplary execution of a TileCompressQuad instruction according to some embodiments;

[0033] FIG. 21G illustrates an exemplary execution of a TileDecompress-Compress instruction according to some embodiments;

[0034] FIG. 21H illustrates an exemplary execution of a TileCompress-Decompress instruction according to some embodiments;

[0035] FIG. 22 illustrates a processing flow of a processor executing a TileCompress instruction according to some embodiments;

[0036] FIG. 23 illustrates a processing flow of a processor executing a TileDecompress instruction according to some embodiments;

[0037] FIG. 24 is a block diagram illustrating a format of various TileCompress and TileDecompress instructions according to some embodiments;

[0038] FIGS. 25A-25B are block diagrams illustrating a generic vector friendly instruction format and instruction templates thereof according to embodiments;

[0039] FIG. 25A is a block diagram illustrating a generic vector friendly instruction format and class A instruction templates thereof according to embodiments;

[0040] FIG. 25B is a block diagram illustrating the generic vector friendly instruction format and class B instruction templates thereof according to embodiments;

[0041] FIG. 26A is a block diagram illustrating an exemplary specific vector friendly instruction format according to embodiments;

[0042] FIG. 26B is a block diagram illustrating the fields of the specific vector friendly instruction format that make up the full opcode field according to one embodiment;

[0043] FIG. 26C is a block diagram illustrating the fields of the specific vector friendly instruction format that make up the register index field according to one embodiment;

[0044] FIG. 26D is a block diagram illustrating the fields of the specific vector friendly instruction format that make up the augmentation operation field according to one embodiment;

[0045] FIG. 27 is a block diagram of a register architecture according to one embodiment;

[0046] FIG. 28A is a block diagram illustrating both an exemplary in-order pipeline and an exemplary register renaming, out-of-order issue/execution pipeline according to embodiments;

[0047] FIG. 28B is a block diagram illustrating both an exemplary embodiment of an in-order architecture core and an exemplary register renaming, out-of-order issue/execution architecture core to be included in a processor according to embodiments;

[0048] FIGS. 29A-B illustrate a block diagram of a more specific exemplary in-order core architecture, which core would be one of several logic blocks (including other cores of the same type and/or different types) in a chip;

[0049] FIG. 29A is a block diagram of a single processor core, along with its connection to the on-die interconnect network and with its local subset of the Level 2 (L2) cache, according to embodiments;

[0050] FIG. 29B is an expanded view of part of the processor core in FIG. 29A according to embodiments;

[0051] FIG. 30 is a block diagram of a processor that may have more than one core, may have an integrated memory controller, and may have integrated graphics according to embodiments;

[0052] FIGS. 31-34 are block diagrams of exemplary computer architectures;

[0053] FIG. 31 shown a block diagram of a system in accordance with one embodiment of the present invention;

[0054] FIG. 32 is a block diagram of a first more specific exemplary system in accordance with an embodiment of the present invention;

[0055] FIG. 33 is a block diagram of a second more specific exemplary system in accordance with an embodiment of the present invention;

[0056] FIG. 34 is a block diagram of a System-on-a-Chip (SoC) in accordance with an embodiment of the present invention; and

[0057] FIG. 35 is a block diagram contrasting the use of a software instruction converter to convert binary instructions in a source instruction set to binary instructions in a target instruction set according to embodiments.

## DETAILED DESCRIPTION

[0058] In the following description, numerous specific details are set forth. However, it is understood that embodiments may be practiced without these specific details. In other instances, well-known circuits, structures and techniques have not been shown in detail in order not to obscure the understanding of this description.

[0059] References in the specification to “one embodiment,” “an embodiment,” “an example embodiment,” etc., indicate that the embodiment described may include a particular feature, structure, or characteristic, but every embodiment may not necessarily include the particular feature, structure, or characteristic. Moreover, such phrases are not necessarily referring to the same embodiment. Further, when a particular feature, structure, or characteristic is described in connection with an embodiment, it is submitted that it is within the knowledge of one skilled in the art to affect such feature, structure, or characteristic in connection with other embodiments whether or not explicitly described.

[0060] In many mainstream processors, handling matrices is a difficult and/or instruction intensive task. For example, rows of a matrix could be put into a plurality of packed data (e.g., SIMD or vector) registers and then operated on individually. For example, multiplying two 8x2 matrices may require a load or gather into four 8x1 packed data registers depending upon data sizes. Then the contents of the packed data registers are multiplied. Then the resulting packed data registers are scattered back to memory. While for small matrices this scenario may be acceptable, gathering matrix rows in vector registers, then performing the operation, then scattering the rows back to memory is often not acceptable with larger matrices. Disclosed embodiments offer a better solution.

## Discussion

[0061] Described herein are mechanisms to support matrix operations in computer hardware such as central processing units (CPUs), graphic processing units (GPUs), and accelerators. The matrix operations utilize 2-dimensional (2-D) data structures representing one or more packed regions of memory such as registers. Throughout this description, these 2-D data structures are referred to as tiles. Note that a matrix may be smaller than a tile (use less than all of a tile) or utilize a plurality of tiles (the matrix is larger than the size of any one tile). Throughout the description, matrix (tile) language is used to indicate operations performed using tiles that impact a matrix; whether or not that matrix is larger than any one tile is not typically relevant.

[0062] Each tile may be acted upon by different operations such as those that are detailed herein and include, but are not limited to: matrix (tile) multiplication, tile add, tile subtract, tile diagonal, tile zero, tile transpose, tile dot product, tile broadcast, tile row broadcast, tile column broadcast, tile multiplication, tile multiplication and accumulation, tile move, etc. Additionally, support for operators such as the use of a scale and/or bias may be used with these operations or in support of non-numeric applications in the future, for instance, OpenCL “local memory,” data compression/decompression, etc. Also described herein are instructions for performing tile compress/decompress (TileCompress/Decompress) instructions

[0063] Portions of storage (such as memory (non-volatile and volatile), registers, cache, etc.) are arranged into tiles of

different horizontal and vertical dimensions. For example, a tile may have horizontal dimension of 4 (e.g., four rows of a matrix) and a vertical dimension of 8 (e.g., 8 columns of the matrix). Typically, the horizontal dimension is related to element sizes (e.g., 2-, 4-, 8-, 16-, 32-, 64-, 128-bit, etc.). Multiple datatypes (single precision floating-point, double precision floating-point, integer, etc.) may be supported.

#### Exemplary Usage of Configured Tiles

**[0064]** In some embodiments, tile parameters can be configured. For example, a given tile may be configured to provide tile options. Exemplary tile options include but are not limited to: a number of rows of the tile, a number of columns of the tile, whether the tile is VALID, and whether the tile consists of a PAIR of equal-sized tiles.

**[0065]** FIG. 1A illustrates an embodiment of configured tiles. As shown, 4 kB of application memory 102 have stored thereon 4 1 kB tiles, tile t0 104, tile t1 106, tile t2 108, and tile t3 110. In this example, the 4 tiles do not consist of pairs, and each have elements arranged in rows and columns. Tile t0 104 and tile t1 106 have K rows and N columns of 4-byte elements (e.g., single precision data), where K equals 8 and N=32. Tile t2 108 and tile t3 110 have K rows and N/2 columns of 8-byte elements (e.g., double precision data). As the double precision operands are twice the width of single precision, this configuration is consistent with a palette, used to provide tile options, supplying at least 4 names with total storage of at least 4 kB. In operation, the tiles can be loaded from and stored to memory using load and store operations. Depending upon the instruction encoding scheme used, the amount of available application memory, as well as the size, number, and configuration of available tiles varies.

**[0066]** FIG. 1B illustrates an embodiment of configured tiles. As shown, 4 kB of application memory 122 have stored thereon 2 pairs of 1 kB-tiles, the first pair being tile t4L 124 and tile t4R 126, and the second pair being tile t5L 128 and tile t5R 130. As shown the pairs of tiles are divided into a left tile and a right tile. In other embodiments, the pair of tiles are divided into an even tile and an odd tile. In this example, the 4 tiles each have elements arranged in rows and columns. Tile t4L 124 and tile t4R 126 have K rows and N columns of 4-byte elements (e.g., single precision floating-point data), where K equals 8 and N equals 32. Tile t5L 128 and tile t5R 130 have K rows and N/2 columns of 8-byte elements (e.g., double precision floating-point data). As the double precision operands are twice the width of single precision, this configuration is consistent with a palette, used to provide tile options, supplying at least 2 names with total storage of at least 4 kB. The four tiles of FIG. 1A use 4 names, each naming a 1 kB tile, whereas the 2 pairs of tiles in FIG. 1B can use 2 names to specify the paired tiles. In some embodiments, tile instructions accept a name of a paired tile as an operand. In operation, the tiles can be loaded from and stored to memory using load and store operations. Depending upon the instruction encoding scheme used, the amount of available application memory, as well as the size, number, and configuration of available tiles varies.

**[0067]** In some embodiments, tile parameters are definable. For example, a “palette” is used to provide tile options. Exemplary options include, but are not limited to: the number of tile names, the number of bytes in a row of

storage, the number of rows and columns in a tile, etc. For example, a maximum “height” (number of rows) of a tile may be defined as:

$$\text{Tile Max Rows} = \text{Architected Storage} / (\text{The Number of Palette Names} * \text{The Number of Bytes per row}).$$

**[0068]** As such, an application can be written such that a fixed usage of names will be able to take advantage of different storage sizes across implementations.

**[0069]** Configuration of tiles is done using a tile configuration (“TILECONFIG”) instruction, where a particular tile usage is defined in a selected palette. This declaration includes the number of tile names to be used, the requested number of rows and columns per name (tile), and, in some embodiments, the requested datatype of each tile. In some embodiments, consistency checks are performed during the execution of a TILECONFIG instruction to determine that it matches the restrictions of the palette entry.

#### Exemplary Tile Storage Types

**[0070]** FIG. 2 illustrates several examples of matrix storage. In (A), a tile is stored in memory. As shown, each “row” consists of four packed data elements. To get to the next “row,” a stride value is used. Note that rows may be consecutively stored in memory. Strided memory accesses allows for access of one row to then next when the tile storage does not map the underlying memory array row width.

**[0071]** Tile loads from memory and stores to memory are typically strided accesses from the application memory to packed rows of data. Exemplary TILELOAD and TILESTORE instructions, or other instruction references to application memory as a TILE operand in load-op instructions, are, in some embodiments, restartable to handle (up to) 2\*rows of page faults, unmasked floating-point exceptions, and/or interrupts per instruction.

**[0072]** In (B), a matrix is stored in a tile comprised of a plurality of registers such as packed data registers (single instruction, multiple data (SIMD) or vector registers). In this example, the tile is overlaid on three physical registers. Typically, consecutive registers are used, however, this need not be the case.

**[0073]** In (C), a matrix is stored in a tile in non-register storage accessible to a fused multiple accumulate (FMA) circuit used in tile operations. This storage may be inside of a FMA, or adjacent to it. Additionally, in some embodiments, discussed below, the storage may be for a data element and not an entire row or tile.

**[0074]** The supported parameters for the TMMA architecture are reported via CPUID. In some embodiments, the list of information includes a maximum height and a maximum SIMD dimension. Configuring the TMMA architecture requires specifying the dimensions for each tile, the element size for each tile and the palette identifier. This configuration is done by executing the TILECONFIG instruction.

**[0075]** Successful execution of a TILECONFIG instruction enables subsequent TILE operators. A TILERELLEASEALL instruction clears the tile configuration and disables the TILE operations (until the next TILECONFIG instructions executes). In some embodiments, XSAVE, XSTORE, etc. are used in context switching using tiles. In some embodiments, 2 XCRO bits are used in XSAVE, one for TILECONFIG metadata and one bit corresponding to actual tile payload data.

**[0076]** TILECONFIG not only configures the tile usage, but also sets a state variable indicating that the program is in a region of code with tiles configured. An implementation

may enumerate restrictions on other instructions that can be used with a tile region such as no usage of an existing register set, etc.

**[0077]** Exiting a tile region is typically done with the TILERELSEALL instruction. It takes no parameters and swiftly invalidates all tiles (indicating that the data no longer needs any saving or restoring) and clears the internal state corresponding to being in a tile region.

**[0078]** In some embodiments, tile operations will zero any rows and any columns beyond the dimensions specified by the tile configuration. For example, tile operations will zero the data beyond the configured number of columns (factoring in the size of the elements) as each row is written. For example, with 64-byte rows and a tile configured with 10 rows and 12 columns, an operation writing FP32 elements would write each of the first 10 rows with 12\*4 bytes with output/result data and zero the remaining 4\*4 bytes in each row. Tile operations also fully zero any rows after the first 10 configured rows. When using 1K tile with 64-byte rows, there would be 16 rows, so in this example, the last 6 rows would also be zeroed.

**[0079]** In some embodiments, a context restore instruction (e.g., XRSTOR), when loading data, enforces that the data beyond the configured rows for a tile will be maintained as zero. If there is no valid configuration, all rows are zeroed. XRSTOR of tile data can load garbage in the columns beyond those configured. It should not be possible for XRSTOR to clear beyond the number of columns configured because there is not an element width associated with the tile configuration.

**[0080]** Context save (e.g., XSAVE) exposes the entire TILE storage area when writing it to memory. If XRSTOR loaded garbage data in to the rightmost part of a tile, that data will be saved by XSAVE. XSAVE will write zeros for rows beyond the number specified for each tile.

**[0081]** In some embodiments, tile instructions are restartable. The operations that access memory allow restart after page faults. The computational instructions that deal with floating-point operations also allow for unmasked floating-point exceptions, with the masking of the exceptions controlled by a control and/or status register.

**[0082]** To support restarting instructions after these events, the instructions store information in the start registers detailed below.

## Matrix (Tile) Operation Systems

### Exemplary Hardware Support

**[0083]** FIG. 3 illustrates an embodiment of a system utilizing a matrix (tile) operations accelerator. In this illustration, a host processor/processing system 301 communicates commands 311 (e.g., matrix manipulation operations such as arithmetic or matrix manipulation operations, or load and store operations) to a matrix operations accelerator 307. However, this is shown this way for discussion purposes only. As detailed later, this accelerator 307 may be a part of a processing core. Typically, commands 311 that are tile manipulation operator instructions will refer to tiles as register-register (“reg-reg”) or register-memory (“reg-mem”) format. Other commands such as TILESTORE, TILELOAD, TILECONFIG, etc., do not perform data operations on a tile. Commands may be decoded instructions (e.g., micro-ops) or macro-instructions for the accelerator 307 to handle.

**[0084]** In this example, a coherent memory interface 303 is coupled to the host processor/processing system 301 and matrix operations accelerator 307 such that they can share memory. FIGS. 4 and 5 show different embodiments of how memory is shared using a matrix operations accelerator. As shown in FIG. 4, the host processor 401 and matrix operations accelerator circuitry 405 share the same memory 403. FIG. 5 illustrates an embodiment where the host processor 501 and matrix operations accelerator 505 do not share memory but can access each other’s memory. For example, processor 501 can access tile memory 507 and utilize its host memory 503 as normal. Similarly, the matrix operations accelerator 505 can access host memory 503, but more typically uses its own memory 507. Note these memories may be of different types.

**[0085]** In some embodiments, the matrix operations accelerator 307 includes a plurality of FMAs 309 coupled to data buffers 305 (in some implementations, one or more of these buffers 305 are stored in the FMAs of the grid as shown). The data buffers 305 buffer tiles loaded from memory and/or tiles to be stored to memory (e.g., using a tileload or tilestore instruction). Data buffers may be, for example, a plurality of registers. Typically, these FMAs are arranged as a grid of chained FMAs 309 which are able to read and write tiles. In this example, the matrix operations accelerator 307 is to perform a matrix multiply operation using tiles T0, T1, and T2. At least one of tiles is housed in the FMA grid 309. In some embodiments, all tiles in an operation are stored in the FMA grid 309. In other embodiments, only a subset is stored in the FMA grid 309. As shown, T1 is housed and T0 and T2 are not. Note that A, B, and C refer to the matrices of these tiles which may or may not take up the entire space of the tile.

**[0086]** FIG. 6 illustrates an embodiment of matrix multiply accumulate operation using tiles (“TMMMA”).

**[0087]** The number of rows in the matrix (TILE A 601) matches the number of serial (chained) FMAs comprising the computation’s latency. The number of rows in some embodiments does not match the number of serial FMAs, which can be smaller or larger. An implementation is free to recirculate on a grid of smaller height, but the computation remains the same.

**[0088]** In this illustrated embodiment, the source/destination vector comes from a tile of N rows (TILE C 605) and the grid of FMAs 611 performs N vector-matrix operations resulting in a complete instruction performing a matrix multiplication of tiles. Tile B 603 is the other vector source and supplies “broadcast” terms to the FMAs in each stage.

**[0089]** In operation, in some embodiments, the elements of matrix B (stored in a tile B 603) are spread across the rectangular grid of FMAs. Matrix B (stored in tile A 601) has its elements of a row transposed to match up with the columnar dimension of the rectangular grid of FMAs. At each FMA in the grid, an element of A and B are multiplied and added to the incoming summand (from above in the Figure) and the outgoing sum is passed to the next row of FMAs (or the final output).

**[0090]** The latency of a single step is proportional to K (row height of matrix B) and dependent TMMAs typically have enough source-destination rows (either in a single tile or across tile) to hide that latency. An implementation may also split the SIMD (packed data element) dimension M (row height of matrix A) across time steps, but this simply changes the constant that K is multiplied by. When a



program specifies a smaller K than the maximum enumerated by the TMAcc, an implementation is free to implement this with “masking” or “early outs.”

**[0091]** The latency of an entire TMMA is proportional to  $N \cdot K$ . The repeat rate is proportional to  $N$ . The number of MACs per TMMA instruction is  $N \cdot K \cdot M$ .

**[0092]** FIG. 7 illustrates an embodiment of a subset of the execution of an iteration of a chained fused multiply accumulate instruction. In particular, this illustrates execution circuitry of an iteration of one packed data element position of the destination. In this embodiment, the chained fused multiply accumulate is operating on signed sources wherein the accumulator is  $2 \times$  the input data size.

**[0093]** A first signed source (source 1 701) and a second signed source (source 2 703) each have four packed data elements. Each of these packed data elements stores signed data such as floating-point data. A third signed source (source 3 709) has two packed data elements, each of which stores signed data. The sizes of the first and second signed sources 701 and 703 are half that of the third signed source (initial value or previous result) 709. For example, the first and second signed sources 701 and 703 could have 32-bit packed data elements (e.g., single precision floating-point) while the third signed source 709 could have 64-bit packed data elements (e.g., double precision floating-point).

**[0094]** In this illustration, only the two most significant packed data element positions of the first and second signed sources 701 and 703 and the most significant packed data element position of the third signed source 709 are shown. Of course, the other packed data element positions would also be processed.

**[0095]** As illustrated, packed data elements are processed in pairs. For example, the data of the most significant packed data element positions of the first and second signed sources 701 and 703 are multiplied using a multiplier circuit 705, and the data from second most significant packed data element positions of the first and second signed sources 701 and 703 are multiplied using a multiplier circuit 707. In some embodiments, these multiplier circuits 705 and 707 are reused for other packed data elements positions. In other embodiments, additional multiplier circuits are used so that the packed data elements are processed in parallel. In some contexts, parallel execution is done using lanes that are the size of the signed third source 709. The results of each of the multiplications are added using addition circuitry 711.

**[0096]** The result of the addition of the results of the multiplications is added to the data from most significant packed data element position of the signed source 3 709 (using a different adder 713 or the same adder 711).

**[0097]** Finally, the result of the second addition is either stored into the signed destination 715 in a packed data element position that corresponds to the packed data element position used from the signed third source 709 or passed on to the next iteration if there is one. In some embodiments, a writemask is applied to this storage such that if a corresponding writemask (bit) is set, the storage happens, and, if not set, the storage does not happen.

**[0098]** FIG. 8 illustrates an embodiment of a subset of the execution of an iteration of a chained fused multiply accumulate instruction. In particular, this illustrates execution circuitry of an iteration of one packed data element position of the destination. In this embodiment, the chained fused multiply accumulate is operating on signed sources wherein the accumulator is  $2 \times$  the input data size.

**[0099]** A first signed source (source 1 801) and a second signed source (source 2 803) each have four packed data elements. Each of these packed data elements stores signed data such as integer data. A third signed source (source 3 809) has two packed data elements, each of which stores signed data. The sizes of the first and second signed sources 801 and 803 are half that of the third signed source 809. For example, the first and second signed sources 801 and 803 could have 32-bit packed data elements (e.g., single precision floating-point) the third signed source 809 could have 64-bit packed data elements (e.g., double precision floating-point).

**[0100]** In this illustration, only the two most significant packed data element positions of the first and second signed sources 801 and 803 and the most significant packed data element position of the third signed source 809 are shown. Of course, the other packed data element positions would also be processed.

**[0101]** As illustrated, packed data elements are processed in pairs. For example, the data of the most significant packed data element positions of the first and second signed sources 801 and 803 are multiplied using a multiplier circuit 805, and the data from second most significant packed data element positions of the first and second signed sources 801 and 803 are multiplied using a multiplier circuit 807. In some embodiments, these multiplier circuits 805 and 807 are reused for other packed data elements positions. In other embodiments, additional multiplier circuits are used so that the packed data elements are processed in parallel. In some contexts, parallel execution is done using lanes that are the size of the signed third source (initial value or previous iteration result) 809. The results of each of the multiplications are added to the signed third source 809 using addition/saturation circuitry 813.

**[0102]** Addition/saturation (accumulator) circuitry 813 preserves a sign of an operand when the addition results in a value that is too big. In particular, saturation evaluation occurs on the infinite precision result between the multi-way-add and the write to the destination or next iteration. When the accumulator 813 is floating-point and the input terms are integer, the sum of products and the floating-point accumulator input value are turned into infinite precision values (fixed point numbers of hundreds of bits), the addition of the multiplication results and the third input is performed, and a single rounding to the actual accumulator type is performed.

**[0103]** Unsigned saturation means the output values are limited to a maximum unsigned number for that element width (all 1s). Signed saturation means a value is limited to be in the range between a minimum negative number and a max positive number for that element width (for bytes for example, the range is from  $-128 (= -2^7)$  to  $127 (= 2^7 - 1)$ ).

**[0104]** The result of the addition and saturation check is stored into the signed result 815 in a packed data element position that corresponds to the packed data element position used from the signed third source 809 or passed on to the next iteration if there is one. In some embodiments, a writemask is applied to this storage such that if a corresponding writemask (bit) is set, the storage happens, and, if not set, the storage does not happen.

**[0105]** FIG. 9 illustrates an embodiment of a subset of the execution of an iteration of a chained fused multiply accumulate instruction. In particular, this illustrates execution circuitry of an iteration of one packed data element position

of the destination. In this embodiment, the chained fused multiply accumulate is operating on a signed source and an unsigned source wherein the accumulator is 4× the input data size.

**[0106]** A first signed source (source **1 901**) and a second unsigned source (source **2 903**) each have four packed data elements. Each of these packed data elements has data such as floating-point or integer data. A third signed source (initial value or result **915**) has a packed data element of which stores signed data. The sizes of the first and second sources **901** and **903** are a quarter of the third signed source **915**. For example, the first and second sources **901** and **903** could have 16-bit packed data elements (e.g., word) and the third signed source **915** could have 64-bit packed data elements (e.g., double precision floating-point or 64-bit integer).

**[0107]** In this illustration, the four most significant packed data element positions of the first and second sources **901** and **903** and the most significant packed data element position of the third signed source **915** are shown. Of course, other packed data element positions would also be processed if there are any.

**[0108]** As illustrated, packed data elements are processed in quadruplets. For example, the data of the most significant packed data element positions of the first and second sources **901** and **903** are multiplied using a multiplier circuit **905**, data from second most significant packed data element positions of the first and second sources **901** and **903** are multiplied using a multiplier circuit **907**, data from third most significant packed data element positions of the first and second sources **901** and **903** are multiplied using a multiplier circuit **909**, and data from the least significant packed data element positions of the first and second sources **901** and **903** are multiplied using a multiplier circuit **911**. In some embodiments, the signed packed data elements of the first source **901** are sign extended and the unsigned packed data elements of the second source **903** are zero extended prior to the multiplications.

**[0109]** In some embodiments, these multiplier circuits **905-911** are reused for other packed data elements positions. In other embodiments, additional multiplier circuits are used so that the packed data elements are processed in parallel. In some contexts, parallel execution is done using lanes that are the size of the signed third source **915**. The results of each of the multiplications are added using addition circuitry **913**.

**[0110]** The result of the addition of the results of the multiplications is added to the data from most significant packed data element position of the signed source **3 915** (using a different adder **917** or the same adder **913**).

**[0111]** Finally, the result **919** of the second addition is either stored into the signed destination in a packed data element position that corresponds to the packed data element position used from the signed third source **915** or passed to the next iteration. In some embodiments, a writemask is applied to this storage such that if a corresponding writemask (bit) is set, the storage happens, and, if not set, the storage does not happen.

**[0112]** FIG. 10 illustrates an embodiment of a subset of the execution of an iteration of chained fused multiply accumulate instruction. In particular, this illustrates execution circuitry of an iteration of one packed data element position of the destination. In this embodiment, the chained fused multiply accumulate is operating on a signed source and an unsigned source wherein the accumulator is 4× the input data size.

**[0113]** A first signed source **1001** and a second unsigned source **1003** each have four packed data elements. Each of these packed data elements stores data such as floating-point or integer data. A third signed source **1015** (initial or previous result) has a packed data element of which stores signed data. The sizes of the first and second sources are a quarter of the third signed source **1015** (initial or previous result). For example, the first and second sources could have 16-bit packed data elements (e.g., word) and the third signed source **1015** (initial or previous result) could have 64-bit packed data elements (e.g., double precision floating-point or 64-bit integer).

**[0114]** In this illustration, the four most significant packed data element positions of the first signed source **1001** and the second unsigned source **1003** and the most significant packed data element position of the third signed source **1015** are shown. Of course, other packed data element positions would also be processed if there are any.

**[0115]** As illustrated, packed data elements are processed in quadruplets. For example, the data of the most significant packed data element positions of the first signed source **1001** and the second unsigned source **1003** are multiplied using a multiplier circuit **1005**, data from second most significant packed data element positions of the first signed source **1001** and the second unsigned source **1003** are multiplied using a multiplier circuit **1007**, data from third most significant packed data element positions of the first signed source **1001** and the second unsigned source **1003** are multiplied using a multiplier circuit **1009**, and data from the least significant packed data element positions of the first signed source **1001** and the second unsigned source **1003** are multiplied using a multiplier circuit **1011**. In some embodiments, the signed packed data elements of the first signed source **1001** are sign extended and the unsigned packed data elements of the second unsigned source **1003** are zero extended prior to the multiplications.

**[0116]** In some embodiments, these multiplier circuits **1005-1011** are reused for other packed data elements positions. In other embodiments, additional multiplier circuits are used so that the packed data elements are processed in parallel. In some contexts, parallel execution is done using lanes that are the size of third signed source **1015** (initial or previous result). The result of the addition of the results of the multiplications is added to the data from most significant packed data element position of third signed source **1015** (initial or previous result) using adder/saturation **1013** circuitry.

**[0117]** Addition/saturation (accumulator) circuitry **1013** preserves a sign of an operand when the addition results in a value that is too big or too small for signed saturation. In particular, saturation evaluation occurs on the infinite precision result between the multi-way-add and the write to the destination. When the accumulator **1013** is floating-point and the input terms are integer, the sum of products and the floating-point accumulator input value are turned into infinite precision values (fixed point numbers of hundreds of bits), the addition of the multiplication results and the third input is performed, and a single rounding to the actual accumulator type is performed.

**[0118]** The result **1019** of the addition and saturation check is stored into the signed destination in a packed data element position that corresponds to the packed data element position used from third signed source **1015** (initial or previous result) or passed to the next iteration. In some

embodiments, a writemask is applied to this storage such that if a corresponding writemask (bit) is set, the storage happens, and, if not set, the storage does not happen.

[0119] FIG. 11 illustrates power-of-two sized SIMD implementations wherein the accumulators use input sizes that are larger than the inputs to the multipliers according to an embodiment. Note the source (to the multipliers) and accumulator values may be signed or unsigned values. For an accumulator having  $2\times$  input sizes (in other words, the accumulator input value is twice the size of the packed data element sizes of the sources), table 1101 illustrates different configurations. For byte sized sources, the accumulator uses word or half-precision floating-point (HPFP) values that are 16-bit in size. For word sized sources, the accumulator uses 32-bit integer or single-precision floating-point (SPFP) values that are 32-bit in size. For SPFP or 32-bit integer sized sources, the accumulator uses 64-bit integer or double-precision floating-point (DPFP) values that are 64-bit in size.

[0120] For an accumulator having  $4\times$  input sizes (in other words, the accumulator input value is four times the size of the packed data element sizes of the sources), table 1103 illustrates different configurations. For byte sized sources, the accumulator uses 32-bit integer or single-precision floating-point (SPFP) values that are 32-bit in size. For word sized sources, the accumulator uses 64-bit integer or double-precision floating-point (DPFP) values that are 64-bit in size in some embodiments.

[0121] For an accumulator having  $8\times$  input sizes (in other words, the accumulator input value is eight times the size of the packed data element sizes of the sources), table 1105 illustrates a configuration. For byte sized sources, the accumulator uses 64-bit integer.

[0122] As hinted at earlier, matrix operations circuitry may be included in a core, or as an external accelerator. FIG. 12 illustrates an embodiment of a system utilizing matrix operations circuitry. In this illustration, multiple entities are coupled with a ring interconnect 1245.

[0123] A plurality of cores, core 0 1201, core 1 1203, core 2 1205, and core N 1207 provide non-tile-based instruction support. In some embodiments, matrix operations circuitry 1251 is provided in a core 1203, and in other embodiments matrix operations circuitry 1211 and 1213 are accessible on the ring interconnect 1245.

[0124] Additionally, one or more memory controllers 1223-1225 are provided to communicate with memory 1233 and 1231 on behalf of the cores and/or matrix operations circuitry.

[0125] FIG. 13 illustrates an embodiment of a processor core pipeline supporting matrix operations using tiles. Branch prediction and decode circuitry 1303 performs branch predicting of instructions, decoding of instructions, and/or both from instructions stored in instruction storage 1301. For example, instructions detailed herein may be stored in instruction storage. In some implementations, separate circuitry is used for branch prediction and in some embodiments, at least some instructions are decoded into one or more micro-operations, microcode entry points, microinstructions, other instructions, or other control signals using microcode 1305. The branch prediction and decode circuitry 1303 may be implemented using various different mechanisms. Examples of suitable mechanisms include, but are not limited to, look-up tables, hardware implementations, programmable logic arrays (PLAs), microcode read only memories (ROMs), etc.

[0126] The branch prediction and decode circuitry 1303 is coupled to allocate/rename 1307 circuitry which is coupled, in some embodiments, to scheduler circuitry 1309. In some embodiments, these circuits provide register renaming, register allocation, and/or scheduling functionality by performing one or more of: 1) renaming logical operand values to physical operand values (e.g., a register alias table in some embodiments), 2) allocating status bits and flags to the decoded instruction, and 3) scheduling the decoded instruction for execution on execution circuitry out of an instruction pool (e.g., using a reservation station in some embodiments).

[0127] The scheduler circuitry 1309 represents any number of different schedulers, including reservations stations, central instruction window, etc. The scheduler circuitry 1309 is coupled to, or includes, physical register file(s) 1315. Each of the physical register file(s) 1315 represents one or more physical register files, different ones of which store one or more different data types, such as scalar integer, scalar floating-point, packed integer, packed floating-point, vector integer, vector floating-point, status (e.g., an instruction pointer that is the address of the next instruction to be executed), tiles, etc. In one embodiment, the physical register file(s) 1315 comprises vector registers circuitry, write mask registers circuitry, and scalar registers circuitry. These register circuits may provide architectural vector registers, vector mask registers, and general-purpose registers. The physical register file(s) 1315 is overlapped by a retirement circuit 1317 to illustrate various ways in which register renaming and out-of-order execution may be implemented (e.g., using a reorder buffer(s) and a retirement register file(s); using a future file(s), a history buffer(s), and a retirement register file(s); using a register maps and a pool of registers; etc.). The retirement circuit 1317 and the physical register file(s) 1315 are coupled to the execution circuitry 1311.

[0128] While register renaming is described in the context of out-of-order execution, it should be understood that register renaming may be used in an in-order architecture. While the illustrated embodiment of the processor may also include separate instruction and data cache units and a shared L2 cache unit, alternative embodiments may have a single internal cache for both instructions and data, such as, for example, a Level 1 (L1) internal cache, or multiple levels of internal cache. In some embodiments, the system may include a combination of an internal cache and an external cache that is external to the core and/or the processor. Alternatively, all of the cache may be external to the core and/or the processor.

[0129] The execution circuitry 1311 is a set of one or more execution circuits, including scalar circuitry 1321, vector/SIMD circuitry 1323, and matrix operations circuitry 1327, as well as memory access circuitry 1325 to access cache 1313. The execution circuits perform various operations (e.g., shifts, addition, subtraction, multiplication) and on various types of data (e.g., scalar floating-point, packed integer, packed floating-point, vector integer, vector floating-point). While some embodiments may include a number of execution units dedicated to specific functions or sets of functions, other embodiments may include only one execution unit or multiple execution units that all perform all functions. The scalar circuitry 1321 performs scalar operations, the vector/SIMD circuitry 1323 performs vector/

SIMD operations, and matrix operations circuitry **1327** performs matrix (tile) operations detailed herein.

**[0130]** By way of example, the exemplary register renaming, out-of-order issue/execution core architecture may implement a pipeline as follows: 1) an instruction fetch circuit performs fetch and length decoding stages; 2) the branch and decode circuitry **1303** performs a decode stage; 3) the allocate/rename **1307** circuitry performs an allocation stage and renaming stage; 4) the scheduler circuitry **1309** performs a schedule stage; 5) physical register file(s) (coupled to, or included in, the scheduler circuitry **1309** and allocate/rename **1307** circuitry and a memory unit perform a register read/memory read stage; the execution circuitry **1311** performs an execute stage; 6) a memory unit and the physical register file(s) unit(s) perform a write back/memory write stage; 7) various units may be involved in the exception handling stage; and 8) a retirement unit and the physical register file(s) unit(s) perform a commit stage.

**[0131]** The core may support one or more instructions sets (e.g., the x86 instruction set (with some extensions that have been added with newer versions); the MIPS instruction set of MIPS Technologies of Sunnyvale, Calif.; the ARM instruction set (with optional additional extensions such as NEON) of ARM Holdings of Sunnyvale, Calif.), including the instruction(s) described herein. In one embodiment, the core **1390** includes logic to support a packed data instruction set extension (e.g., AVX1, AVX2), thereby allowing the operations used by many multimedia applications to be performed using packed data.

**[0132]** It should be understood that the core may support multithreading (executing two or more parallel sets of operations or threads), and may do so in a variety of ways including time sliced multithreading, simultaneous multithreading (where a single physical core provides a logical core for each of the threads that physical core is simultaneously multithreading), or a combination thereof (e.g., time sliced fetching and decoding and simultaneous multithreading thereafter such as in the Intel® Hyperthreading technology).

**[0133]** FIG. 14 illustrates an embodiment of a processor core pipeline supporting matrix operations using tiles. Branch prediction and decode circuitry **1403** performs branch predicting of instructions, decoding of instructions, and/or both from instructions stored in instruction storage **1401**. For example, instructions detailed herein may be stored in instruction storage. In some implementations, separate circuitry is used for branch prediction and in some embodiments, at least some instructions are decoded into one or more micro-operations, micro-code entry points, microinstructions, other instructions, or other control signals using microcode **1405**. The branch prediction and decode circuitry **1403** may be implemented using various different mechanisms. Examples of suitable mechanisms include, but are not limited to, look-up tables, hardware implementations, programmable logic arrays (PLAs), microcode read only memories (ROMs), etc.

**[0134]** The branch prediction and decode circuitry **1403** is coupled to allocate/rename **1407** circuitry which is coupled, in some embodiments, to scheduler circuitry **1409**. In some embodiments, these circuits provide register renaming, register allocation, and/or scheduling functionality by performing one or more of: 1) renaming logical operand values to physical operand values (e.g., a register alias table in some embodiments), 2) allocating status bits and flags to the

decoded instruction, and 3) scheduling the decoded instruction for execution on execution circuitry out of an instruction pool (e.g., using a reservation station in some embodiments).

**[0135]** The scheduler circuitry **1409** represents any number of different schedulers, including reservations stations, central instruction window, etc. The scheduler unit(s) scheduler circuitry **1409** is coupled to, or includes, physical register file(s) **1415**. Each of the physical register file(s) **1415** represents one or more physical register files, different ones of which store one or more different data types, such as scalar integer, scalar floating-point, packed integer, packed floating-point, vector integer, vector floating-point, status (e.g., an instruction pointer that is the address of the next instruction to be executed), tiles, etc. In one embodiment, the physical register file(s) **1415** comprises vector registers circuitry, write mask registers circuitry, and scalar registers circuitry. These register circuits may provide architectural vector registers, vector mask registers, and general-purpose registers. The physical register file(s) **1415** is overlapped by a retirement circuit **1417** to illustrate various ways in which register renaming and out-of-order execution may be implemented (e.g., using a reorder buffer(s) and a retirement register file(s); using a future file(s), a history buffer(s), and a retirement register file(s); using a register maps and a pool of registers; etc.). The retirement circuit **1417** and the physical register file(s) **1415** are coupled to the execution circuitry **1411**.

**[0136]** While register renaming is described in the context of out-of-order execution, it should be understood that register renaming may be used in an in-order architecture. While the illustrated embodiment of the processor may also include separate instruction and data cache units and a shared L2 cache unit, alternative embodiments may have a single internal cache for both instructions and data, such as, for example, a Level 1 (L1) internal cache, or multiple levels of internal cache. In some embodiments, the system may include a combination of an internal cache and an external cache that is external to the core and/or the processor. Alternatively, all of the cache may be external to the core and/or the processor.

**[0137]** The execution circuitry **1411** a set of one or more execution circuits **1427** and a set of one or more memory access circuits **1425** to access cache **1413**. The execution circuits **1427** perform matrix (tile) operations detailed herein.

**[0138]** By way of example, the exemplary register renaming, out-of-order issue/execution core architecture may implement a pipeline as follows: 1) an instruction fetch circuit performs fetch and length decoding stages; 2) the branch and decode circuitry **1403** performs a decode stage; 3) the allocate/rename **1407** circuitry performs an allocation stage and renaming stage; 4) the scheduler circuitry **1409** performs a schedule stage; 5) physical register file(s) (coupled to, or included in, the scheduler circuitry **1409** and allocate/rename **1407** circuitry and a memory unit perform a register read/memory read stage; the execution circuitry **1411** performs an execute stage; 6) a memory unit and the physical register file(s) unit(s) perform a write back/memory write stage; 7) various units may be involved in the exception handling stage; and 8) a retirement unit and the physical register file(s) unit(s) perform a commit stage.

**[0139]** The core may support one or more instructions sets (e.g., the x86 instruction set (with some extensions that have

been added with newer versions); the MIPS instruction set of MIPS Technologies of Sunnyvale, Calif.; the ARM instruction set (with optional additional extensions such as NEON) of ARM Holdings of Sunnyvale, Calif.), including the instruction(s) described herein. In one embodiment, the core 1490 includes logic to support a packed data instruction set extension (e.g., AVX1, AVX2), thereby allowing the operations used by many multimedia applications to be performed using packed data.

[0140] It should be understood that the core may support multithreading (executing two or more parallel sets of operations or threads), and may do so in a variety of ways including time sliced multithreading, simultaneous multithreading (where a single physical core provides a logical core for each of the threads that physical core is simultaneously multithreading), or a combination thereof (e.g., time sliced fetching and decoding and simultaneous multithreading thereafter such as in the Intel® Hyperthreading technology).

Layout

[0141] Throughout this description, data is expressed using row major data layout. Column major users should translate the terms according to their orientation. FIG. 15 illustrates an example of a matrix expressed in row major format and column major format. As shown, matrix A is a 2x3 matrix. When this matrix is stored in row major format, the data elements of a row are consecutive. When this matrix is stored in column major format, the data elements of a column are consecutive. It is a well-known property of matrices that  $A^T * B^T = (BA)^T$ , where superscript T means transpose. Reading column major data as row major data results in the matrix looking like the transpose matrix.

[0142] In some embodiments, row-major semantics are utilized in hardware, and column major data is to swap the operand order with the result being transposes of matrix, but for subsequent column-major reads from memory it is the correct, non-transposed matrix.

[0143] For example, if there are two column-major matrices to multiply:

a b	g i k	ag + bh ai + bj ak + bl
c d *	h j l=	cg + dh ci + dj ck + dl
e f	eg + fh ei + fj ek + fl	
(3 x 2)	(2 x 3)	(3 x 3)

[0144] The input matrices would be stored in linear memory (column-major) as:

[0145] a c e b d f

[0146] and

[0147] g h i j k l.

[0148] Reading those matrices as row-major with dimensions 2x3 and 3x2, they would appear as:

a c e	and	g h
b d f		i j
k l		

[0149] Swapping the order and matrix multiplying:

g h	a c e	ag + bh cg + dh eg + fh
i j	b d f=	ai + bj ci + dj ei + fj
k l		ak + bl ck + dl ek + fl

[0150] the transpose matrix is out and can then be stored in in row-major order:

[0151] ag+bh cg+dh eg+fh ai+bj ci+dj ei+fj ak+bl ck+dl ek+fl

[0152] and used in subsequent column major computations, it is the correct un-transposed matrix:

ag + bh	ai + bj	ak + bl
cg + dh	ci + dj	ck + dl
eg + fh	ei + fj	ek + fl

Exemplary Usage

[0153] FIG. 16 illustrates an example of usage of matrices (tiles). In this example, matrix C 1601 includes two tiles, matrix A 1603 includes one tile, and matrix B 1605 includes two tiles.

[0154] This figure shows an example of the inner loop of an algorithm to compute a matrix multiplication. In this example, two result tiles, tmm0 and tmm1, from matrix C 1601 are used to accumulate the intermediate results. One tile from the matrix A 1603 (tmm2) is re-used twice as it multiplied by two tiles from matrix B 1605. Pointers to load a new A matrix (tile) and two new B matrices (tiles) from the directions indicated by the arrows. An outer loop, not shown, adjusts the pointers for the C tiles.

[0155] The exemplary code as shown includes the usage of a tile configuration instruction and is executed to configure tile usage, load tiles, a loop to process the tiles, store tiles to memory, and release tile usage.

[0156] FIG. 17 illustrates an embodiment of usage of matrices (tiles). At 1701, tile usage is configured. For example, a TILECONFIG instruction is executed to configure tile usage including setting a number of rows and columns per tile. Typically, at least one matrix (tile) is loaded from memory at 1703. At least one matrix (tile) operation is performed at 1705 using the matrices (tiles). At 1707, at least one matrix (tile) is stored out to memory and a context switch can occur at 1709.

Exemplary Configuration

Tile Configuration Hardware Support

[0157] As discussed above, tile usage typically needs to be configured prior to use. For example, full usage of all rows and columns may not be needed. Not only does not configuring these rows and columns save power in some embodiments, but the configuration may be used to determine if an operation will generate an error. For example, a matrix multiplication of the form (NxM)\*(LxN) will typically not work if M and L are not the same.

[0158] Prior to using matrices using tiles, in some embodiments, tile support is to be configured. For example, how many rows and columns per tile, tiles that are to be used, etc. are configured. A TILECONFIG instruction is an improvement to a computer itself as it provides for support to

configure the computer to use a matrix accelerator (either as a part of a processor core, or as an external device). In particular, an execution of the TILECONFIG instruction causes a configuration to be retrieved from memory and applied to matrix (tile) settings within a matrix accelerator.

#### Tile Usage Configuration

[0159] FIG. 18 illustrates support for configuration of the usage of tiles according to an embodiment. A memory 1801 contains the tile description 1803 of the matrices (tiles) to be supported.

[0160] Instruction execution resources 1811 of a processor/core 1805 stores aspects of a tile description 1803 into tile configurations 1817. The tile configurations 1817 include palette table 1813 to detail what tiles for a palette are configured (the number of rows and columns in each tile) and a marking that matrix support is in use. In particular, instruction execution resources 1811 are configured to use tiles as specified by the tile configurations 1817. The instruction execution resources 1811 may also include a machine specific register or configuration register to indicate tile usage. Additional values such as in-use and start values are also set. The tile configurations 1817 utilize register(s) 1819 to store tile usage and configuration information.

[0161] FIG. 19 illustrates an embodiment of a description of the matrices (tiles) to be supported. This is the description that is to be stored upon an execution of a STTILECFG instruction. In this example, each field is a byte. In byte [0], a palette ID 1901 is stored. The palette ID is used to index a palette table 1813 which stores, per palette ID, a number of bytes in a tile, and bytes per row of the tiles that are associated with this ID as defined by the configuration.

[0162] Byte 1 stores a value to be stored in a “startRow” register 1903 and byte 2 stores a value to be stored in a register, startP 1905. To support restarting instructions after these events, the instructions store information these registers. To support restarting instructions after break events such as those detailed above, the instructions store information in these registers. The startRow value indicates the row that should be used for restart. The startP value indicates the position within the row for store operations when pairs are used and, in some embodiments, indicates the lower half of the row (in the lower tile of a pair) or higher half of the row (in the higher tile of a pair). Generally, the position in the row (the column) is not needed.

[0163] With the exception of TILECONFIG and STTILECFG, successfully executing matrix (tile) instructions will set both startRow and startP to zero.

[0164] Any time an interrupted matrix (tile) instruction is not restarted, it is the responsibility of software to zero the startRow and startP values. For example, unmasked floating-point exception handlers might decide to finish the operation in software and change the program counter value to another instruction, usually the next instruction. In this case the software exception handler must zero the startRow and startP values in the exception presented to it by the operating system before resuming the program. The operating system will subsequently reload those values using a restore instruction.

[0165] Byte 3 stores an indication of pairs (1b per tile) of tiles 1907.

[0166] Bytes 16-17 store the number of rows 1913 and columns 1915 for tile 0, bytes 18-19 store the number of rows and columns for tile 1, etc. In other words, each 2-byte

group specifies a number of rows and columns for a tile. If a group of 2 bytes is not used to specify tile parameters, they should have the value zero. Specifying tile parameters for more tiles than the implementation limit or the palette limit results in a fault. Unconfigured tiles are set to an initial state with 0 rows, 0 columns.

[0167] Finally, the configuration in memory typically ends with an ending delineation such as all zeros for several consecutive bytes.

#### Exemplary Tile and Tile Configuration Storage

[0168] FIGS. 20(A)-(D) illustrate examples of register(s) 1819. FIG. 20(A) illustrates a plurality of registers 1819. As shown each tile (TMM0 2001 . . . TMMN 2003) has a separate register with each register storing a row and column size for that particular tile. StartP 2011 and StartRow 2013 are stored in separate registers. One or more status registers 2015 are set (e.g., TILES\_CONFIGURED=1) to indicate tiles are configured for use.

[0169] FIG. 20(B) illustrates a plurality of registers 1819. As shown each tile has separate registers for its rows and columns. For example, TMM0 rows configuration 2021, TMM0 columns configuration 2023, StartP 2011 and StartRow 2013 are stored in separate registers. One or more status registers 2015 are set (e.g., TILES\_CONFIGURED=1) to indicate tiles are configured for use.

[0170] FIG. 20(C) illustrates a single register 1819. As shown, this register stores tile configurations (rows and columns per tile) 2031, StartP 2011, and StartRow 2013 are stored in single register as packed data registers. One or more status registers 2015 are set (e.g., TILES\_CONFIGURED=1) to indicate tiles are configured for use.

[0171] FIG. 20(D) illustrates a plurality of registers 1819. As shown, a single register stores tile configuration (rows and columns per tile) 2031. StartP and StartRow are stored in separate registers 2011 and 2013. One or more status registers 2015 are set (e.g., TILES\_CONFIGURED=1) to indicate tiles are configured for use.

[0172] Other combinations are contemplated such as combining the start registers into a single register where they are shown separately, etc.

#### Matrix Compress and Decompress Instructions

[0173] Disclosed embodiments describe instructions, sometimes referred to as TileCompress or TileDecompress instructions, for performing compression or decompression of matrices (tiles), respectively. Disclosed embodiments compress and decompress matrices while loading them into registers or while storing them to memory. Several compression algorithms are described.

[0174] The disclosed TileCompress and TileDecompress instructions improve processor performance by reducing the size of data being transferred and maintained. With less data to transfer, memory accesses take less time. Since memory accesses are often a system-wide performance bottleneck, improvements to memory access performance are expected to also improve overall system performance.

[0175] In some embodiments, matrices are compressed before being stored to memory, such as an L1 data cache. When compressed matrix data is stored to a lower-level cache, it advantageously maintains its smaller size throughout different levels of a memory hierarchy, effectively increasing the size of available memory.

**[0176]** In some embodiments, matrices are compressed by replacing zero-valued elements with non-zero-valued elements, leaving only non-zero-valued elements to multiply, and avoiding expending power to multiply by zero.

**[0177]** Processing of TileCompress/Decompress instructions according to some embodiments is illustrated and described with respect to FIGS. 21A-23. A format of the TileCompress/Decompress instructions according to disclosed embodiments is illustrated and described with respect to FIGS. 24-26D. Processors having execution circuitry to process TileCompress/Decompress instructions are further illustrated and described with respect to FIGS. 28-31. Computing systems for processing TileCompress/Decompress instructions are further illustrated and described with respect to FIGS. 32-35.

**[0178]** In operation, a result of the compress operation is generated for each element of the specified decompressed source matrix. In some embodiments, a result of the compress operation is generated for two or more elements of the specified decompressed source matrix. Some generated results are moved to a different relative position within the specified compressed destination matrix, for example, to replace a zero-valued element with non-zero-valued elements. Some generated results maintain the same relative position within the specified destination matrix, but use fewer bits for the value, for example, a double-precision floating-point valued of the decompressed source matrix can be replaced with a few bits to specify a dictionary entry. The elements of the specified compressed source matrix and decompressed destination matrix may be collections of values in any of floating-point registers, vector registers, tile registers, and memory.

**[0179]** In some embodiments, tile registers are supported using an overlay over physical registers. For example, a tile may utilize 16 1,024-bit registers, 32 512-bit registers, etc. depending on the implementation. In some embodiments, matrix operations utilize tile registers comprising 2-dimensional (2-D) data structures representing one or more packed regions of memory such as registers. Throughout this description, these 2-D data structures are referred to as tiles or tile registers.

**[0180]** Some compression techniques use headers, which can be stored in a register or in memory. An exemplary processor register file for use with disclosed embodiments is further illustrated and described with respect to FIG. 27.

#### Compression Algorithms

**[0181]** Several different compression/decompression algorithms are supported by disclosed embodiments.

Replace Zero-Valued Elements with Non-Zero-Valued Ones

**[0182]** As mentioned above, one of the disclosed compression algorithms calls for searching matrices to find zero-valued elements and replacing them with non-zero-valued elements. In so doing, the disclosed compression algorithm orders all non-zero-valued elements consecutively, allowing them to be read without wasting memory bandwidth to read the zero-valued elements. See, for example, FIG. 21B and FIG. 21C. In some embodiments, a header is stored in memory or in a register and contains the logical matrix positions of the non-zero-valued elements that have been moved. Tiles can be accompanied by bitmasks that specify the destination to which elements should be written.

Replace Common Values with a Reference to a Dictionary Entry

**[0183]** A dictionary approach may also be applied, targeting cases where most of the values are a small subset of the entire possible range. Such an embodiment is illustrated and described, for example, with respect to FIG. 21E. The embodiment illustrated in FIG. 21E uses a bitmask to indicate which elements are to use a dictionary. Alternatively, each data element could include a prefix to indicate whether to use a dictionary.

Use an Approximate Value to Replace any Value in a Range of Values

**[0184]** Though not shown in any Figures, a similar approach to the dictionary substitution described above and shown in FIG. 21E is to use an approximate value to replace elements within a range of values. For example, floating-point numbers between, say, 4.9 and 5.1 may be replaced with a pointer to an approximate equivalent, 5.0, in a list or dictionary of approximate values.

Specifying a Compressed Element's Matrix Position

**[0185]** In some embodiments, for example, as shown in FIG. 21F, a compressed matrix is associated with a bitmask header, such as bitmask header 2168B of FIG. 21F. The header has one bit per element and is used to represent the logical matrix position of each non-zero-valued element. For example, with reference to FIG. 21F, compressed destination matrix 2168 is a 64-entry matrix having 15 non-zero-valued elements, and 64-bit non-zero-element position bitmask 2168B includes 15 bits set to '1' to represent the logical matrix position of each non-zero value element. In other embodiments, a value of '0' can be used to represent non-zero-valued elements. The header can be in the compressed tile, or in a different location in the memory, or in a register. In some embodiments, the header and/or the bitmask are compressed to get even more efficient compression.

**[0186]** In some embodiments, the matrix position is specified as an index to the logical position of the compressed element in its associated matrix and value.

**[0187]** In some embodiments, such as compressed matrix 2144 of FIG. 21D, non-zero values and their location index are interleaved with the values. In other embodiments, the location indices are store in a different header or memory location.

**[0188]** As described above, in a dictionary approach, common values are replaced with an index into a list, or dictionary of values.

Format of Compressed Matrices (Tiles)

**[0189]** As described herein, decompressed matrices are arrays, for example arrays having M rows and N columns, of elements having various different formats, including, for example, 32-bit single-precision and 64-bit double-precision single-precision floating-point, or double-precision floating-point, and also 4-bit, 8-bit, 16-bit, and 32-bit integer.

**[0190]** When compressed, however, the MxN matrix has either fewer non-zero elements, or fewer average bits per element, or both. In particular, in some embodiments, compressing the source matrix (tile) calls for moving non-zero elements to take the place of zero-valued elements. Dis-

closed embodiments describe how to keep track of the original position of such an element that has moved.

Compressed Format: Header Per-Row Identifies Non-Zero Elements

[0191] FIG. 21B illustrates an exemplary compressed matrix 2128 having 8 rows and 8 columns of matrix elements 2128A, with the non-zero elements packed to the left. Also shown are 8-bit headers non-zero positions 2128B, with one header per row indicating the original position of each of the packed nonzero elements in the original, uncompressed matrix 2124. For example, element 'A,' the only non-zero element in the first row of the uncompressed matrix is packed to the left of the compressed matrix, and the 8-bit header for the first row is 0100-0000, indicating that 'A' occupies logical position 1 of the decompressed source matrix (tile).

[0192] As shown, each row of compressed destination 2128 consists of an 8-bit header, and up to eight non-zero elements. In some embodiments, for example when each row of compressed destination is stored in a 128-bit register, and supposing each of the elements is a 16-bit word, there is no room left in the register to store the 8-bit header. In some such embodiments, one of the register elements that was to store data instead stores a header. For example, in some embodiments, each row of the compressed destination consists of 7 data elements and element being used for the header.

[0193] FIG. 21C illustrates an exemplary compressed matrix 2138 having 8 rows and 8 columns of matrix elements 2138A, with the non-zero elements packed into the first two rows. Advantageously, the third through eighth rows of matrix elements 2138A can be ignored subsequently, because they only contain zeroes. Also shown are 8-bit headers non-zero positions 2138B, with one header per row indicating the original position of each of the packed non-zero elements in the original, uncompressed matrix 2134. For example, the packed matrix elements 2138A include fourteen (14) non-zero-valued elements packed into the first two rows, and the eight headers together have fourteen (14) bits set to indicate the original positions of those non-zero-valued elements.

Compressed Format: Logical Matrix Position Stored with Each Element

[0194] FIG. 21D illustrates another exemplary format for the compressed matrix (tile). Here, compressed source matrix 2144 has 8 rows and 8 columns, and includes a 9-bit matrix position with each element, zero-valued elements have a matrix position equal to 64. All zero-valued elements, for illustrative purposes, have been shown as having a matrix position equal to 64. But, in operation, a single value of 64 could be applied to zero-valued elements.

Compressed Format: Substitute Dictionary Entry for Identified Elements

[0195] FIG. 21E illustrates another exemplary format for the compressed matrix (tile). Here, compressed matrix 2158A has 64 entries, 12 of which are to be substituted with an element from dictionary 2158C. Destination elements not using the dictionary are illustrated with an 'x,' to signify a Don't Care value. Use dictionary 2158B is a sequence of eight headers, one per row, which are multibit selectors to indicate which elements of the row are to be substituted with

a dictionary entry. Beneficially, the elements to be substituted, otherwise consisting of 32 or 64 bits, only need two bits to select one of four dictionary entries.

Compressed Format: Some Tolerable Loss in Accuracy

[0196] In some embodiments, the compressed format calls for replacing one or more elements with an approximate value. Here, the compressed format could follow the example of FIG. 21E, where one or more values of the compressed matrix are to be substituted with an approximate value taken from dictionary 2158C.

[0197] In some embodiments, the compression calls for replacing numbers within a range of values with an approximate substitute. For example, in some embodiments, with respect to FIG. 21E, execution circuitry 2156 is to replace any element having a value between 4.9 and 5.3 with 5.1. Using an approximate value may sacrifice some accuracy, but may also allow more 32/64 bit elements to be replaced with a 2-bit dictionary index.

Exemplary Execution

[0198] FIG. 21A is a block diagram of hardware processing components used to execute TileCompress/Decompress instructions, according to some embodiments. As shown, computing system 2100 includes code storage 2102 (to store TileCompress/Decompress instructions), fetch circuitry 2104 (to fetch TileCompress/Decompress instructions) and decode circuitry 2106 (to decode fetched instructions). Computing system 2100 further includes execution circuitry 2108, decompress circuitry 2110, compress circuitry 2112, registers 2114, buffer 2116, memory 2118, and optionally, retire or commit circuit 2119. Decompress circuitry 2110 and compress circuitry 2112 are shown surrounded by a dashed border, which is to indicate that those circuits could in some embodiments be incorporated into execution circuitry 2108.

[0199] In the context of the illustrated system, decode circuitry is similar to that illustrated and described at least with respect to FIGS. 13, 14, and 28A-B.

[0200] As shown, TileCompress/Decompress instruction 2101 includes fields to specify an opcode 2101A (e.g., TileCompress or TileDecompress), a destination matrix location 2101B, a compress or decompress algorithm 2101C, and a source matrix (tile) location 2101D. As disclosed herein, source and destination matrices identified by TileCompress/Decompress instructions can be located in any of registers 2114, buffer 2116, and memory 2118.

[0201] In operation, computing system 2100 is to use fetch circuitry 2104 and decode circuitry 2106 to fetch and decode TileCompress/Decompress instructions from code storage 2102. Execution circuitry is to respond to a decoded TileCompress/Decompress instruction by using the compress circuitry 2112 to respond to TileCompress instructions, performing arithmetic and/or logical operations on matrices, and using the decompress circuitry 2110 to respond to TileDecompress instructions.

[0202] Execution circuitry is further illustrated and described with respect to FIGS. 3-14. In some embodiments, execution circuitry is a matrix operations accelerator, such as that illustrated and described as accelerator 307 (FIG. 3). In some embodiments, execution circuitry is a matrix operations circuit, such as matrix operations circuitry 405 (FIG. 4), 505 (FIG. 5), or 1213 (FIG. 12), and 1327 (FIG. 13).



[0203] FIG. 21B illustrates execution of a TileCompress instruction, according to some embodiments. As shown, TileCompress instruction 2122 includes fields to specify an opcode 2122A (e.g., TileCompress), a compressed destination matrix location 2122B, a compress algorithm 2122C, and a decompressed source matrix location 2122D. Also shown are the specified source matrix 2124, execution circuitry 2126, which includes compress circuitry, and the specified compressed destination matrix 2128.

[0204] In the context of the illustrated system, decode circuitry is similar to that illustrated and described at least with respect to FIGS. 13, 14, and 28A-B.

[0205] Execution circuitry is further illustrated and described with respect to FIGS. 3-14. In some embodiments, execution circuitry is a matrix operations accelerator, such as that illustrated and described as accelerator 307 (FIG. 3). In some embodiments, execution circuitry is a matrix operations circuit, such as matrix operations circuitry 405 (FIG. 4), 505 (FIG. 5), or 1213 (FIG. 12), and 1327 (FIG. 13).

[0206] In operation, a computing system 2120 is to process a TileCompress instruction 2122 by generating a result matrix requiring fewer bits of storage than the specified decompressed source matrix by either packing non-zero-valued elements over zero-valued elements, as is done here, or by reducing an average bit size of matrix elements by replacing one or more floating-point values with dictionary pointers to one or more items in a list of floating-point values, as is shown in FIG. 21E. Using such a dictionary approach allows the matrix to be represented with fewer bits because each dictionary pointer comprises fewer bits than its associated matrix element.

[0207] FIG. 21C illustrates execution of a TileCompress instruction, according to some embodiments. As shown, TileCompress instruction 2132 includes fields to specify an opcode 2132A (e.g., TileCompress), a compressed destination matrix location 2132B, a compress algorithm 2132C, and a decompressed source matrix location 2132D. Also shown are the specified source matrix 2134, execution circuitry 2136, which includes compress circuitry, and the specified compressed destination matrix 2138. Here, the non-zero-valued elements of the source matrix 2134 have been packed into the first two rows of the destination matrix 2138. In operation, a processor is to minimize usage of memory bandwidth by reading just the first two rows and ignoring the rest.

[0208] In the context of the illustrated system, decode circuitry is similar to that illustrated and described at least with respect to FIGS. 13, 14, and 28A-B.

[0209] Execution circuitry is further illustrated and described with respect to FIGS. 3-14. In some embodiments, execution circuitry is a matrix operations accelerator, such as that illustrated and described as accelerator 307 (FIG. 3). In some embodiments, execution circuitry is a matrix operations circuit, such as matrix operations circuitry 405 (FIG. 4), 505 (FIG. 5), or 1213 (FIG. 12), and 1327 (FIG. 13).

[0210] In operation, a computing system 2130 is to process a TileCompress instruction 2132 by generating a result matrix requiring fewer bits of storage than the specified decompressed source matrix by either packing non-zero-valued elements over zero-valued elements, as is done here, or by reducing an average bit size of matrix elements by replacing one or more floating-point values with dictionary pointers to one or more items in a list of floating-point values, as is shown in FIG. 21E. Using such a dictionary

approach allows the matrix to be represented with fewer bits because each dictionary pointer comprises fewer bits than its associated matrix element.

[0211] FIG. 21D illustrates execution of a TileDecompress instruction according to some embodiments. As shown, TileDecompress instruction 2142 includes fields to specify an opcode 2142A (e.g., TileDecompress), a decompressed destination matrix location 2142B, a decompress algorithm 2142C, and a compressed source matrix location 2142D. Also shown are the specified compressed source matrix 2144, execution circuitry 2146, which includes decompress circuitry, and the specified decompressed destination matrix 2148.

[0212] In the context of the illustrated system, decode circuitry is similar to that illustrated and described at least with respect to FIGS. 13, 14, and 28A-B.

[0213] Execution circuitry is further illustrated and described with respect to FIGS. 3-14. In some embodiments, execution circuitry is a matrix operations accelerator, such as that illustrated and described as accelerator 307 (FIG. 3). In some embodiments, execution circuitry is a matrix operations circuit, such as matrix operations circuitry 405 (FIG. 4), 505 (FIG. 5), or 1213 (FIG. 12), and 1327 (FIG. 13).

[0214] In operation, a computing system 2140 is to use fetch circuitry to fetch a TileDecompress instruction 2142 specifying a decompress algorithm 2142C and locations of compressed source matrix 2144, specified by 2142D, and decompressed destination matrix 2148, specified by 2142B, wherein the specified compressed source matrix was generated as in FIG. 21B by packing non-zero-valued elements over zero-valued elements and storing an associated matrix position for each of the non-zero-valued elements that was moved during the packing, a TileDecompress instruction by writing each of the non-zero-valued elements to its associated matrix position within the specified destination matrix 2148 and writing any remaining values of the specified destination matrix 2148 to zero.

[0215] FIG. 21E illustrates execution of a TileCompress instruction, according to some embodiments. As shown, TileCompress instruction 2152 includes fields to specify an opcode 2152A (e.g., TileCompress), a compressed destination matrix location 2152B, a compress algorithm 2152C, and a decompressed source matrix location 2152D. Also shown are the specified decompressed source matrix 2154, execution circuitry 2156, which includes compress circuitry, and the specified compressed destination matrix 2158, which includes matrix elements 2158A and use dictionary 2158B headers consisting of 8-bit headers for each row.

[0216] In the context of the illustrated system, decode circuitry is similar to that illustrated and described at least with respect to FIGS. 13, 14, and 28A-B.

[0217] Execution circuitry is further illustrated and described with respect to FIGS. 3-14. In some embodiments, execution circuitry is a matrix operations accelerator, such as that illustrated and described as accelerator 307 (FIG. 3). In some embodiments, execution circuitry is a matrix operations circuit, such as matrix operations circuitry 405 (FIG. 4), 505 (FIG. 5), or 1213 (FIG. 12), and 1327 (FIG. 13).

[0218] In operation, a computing system 2150 is to process a TileCompress instruction by generating a result matrix requiring fewer bits of storage than the specified decompressed source matrix by reducing an average bit size of matrix elements by replacing one or more floating-point values with dictionary pointers to a dictionary, or list of

floating-point values, each dictionary pointer comprising fewer bits than its associated matrix element. Here, the dictionary pointers each only require 2 bits.

[0219] FIG. 21F illustrates execution of a TileCompressQuad instruction, according to some embodiments. As shown, TileCompressQuad instruction 2162 includes fields to specify an opcode 2162A (e.g., TileCompressQuad), a compressed destination matrix location 2162B, a compress algorithm 2162C, and a decompressed source matrix location 2162D. Also shown are the specified decompressed source matrix 2164, execution circuitry 2166, which includes compress circuitry, and the specified compressed destination matrix 2168, which includes matrix elements 2168A and non-zero element position bitmask 2168B.

[0220] In the context of the illustrated system, decode circuitry is similar to that illustrated and described at least with respect to FIGS. 13, 14, and 28A-B.

[0221] Execution circuitry is further illustrated and described with respect to FIGS. 3-14. In some embodiments, execution circuitry is a matrix operations accelerator, such as that illustrated and described as accelerator 307 (FIG. 3). In some embodiments, execution circuitry is a matrix operations circuit, such as matrix operations circuitry 405 (FIG. 4), 505 (FIG. 5), or 1213 (FIG. 12), and 1327 (FIG. 13).

[0222] In operation, a computing system 2160 is to process a TileCompressQuad instruction 2162 by generating a result matrix requiring fewer bits of storage than the specified decompressed source matrix by packing non-zero-valued elements over zero-valued elements, as is illustrated and described with respect to FIG. 21B. But here, the uncompressed source matrix 2164 has been partitioned into four quadrants, and the non-zero values for each quadrant are written to a different row of specified destination matrix.

[0223] FIG. 21G illustrates execution of a TileDecompressOpCompress instruction, according to some embodiments. As shown, TileDecompressOpCompress instruction 2172 includes fields to specify an opcode 2172A (e.g., TileDecompressOpCompress), a compressed destination matrix location 2172B, a decompress algorithm 2172C, a compressed source matrix location 2172D, an arithmetic or logical op 2172E, and a compress algorithm 2172F. Also shown are the specified compressed source matrix 2174, which includes matrix elements 2174A and non-zero select 2174B, execution circuitry 2176, which includes decompress circuitry, arithmetic or logical operation circuitry, and compress circuitry, and the specified compressed destination matrix 2178, which includes matrix elements 2178A and non-zero element position bitmask 2178B.

[0224] Execution circuitry is further illustrated and described with respect to FIGS. 3-14. In some embodiments, execution circuitry is a matrix operations accelerator, such as that illustrated and described as accelerator 307 (FIG. 3). In some embodiments, execution circuitry is a matrix operations circuit, such as matrix operations circuitry 405 (FIG. 4), 505 (FIG. 5), or 1213 (FIG. 12), and 1327 (FIG. 13)

[0225] In operation, a computing system 2170 is to respond to a decoded decompress instruction specifying a compressed source matrix location, a decompression algorithm, and a decompressed destination matrix location by copying each element of the specified source matrix to its associated matrix position in the specified destination matrix. The processor is then to generate a result of an operation on the specified destination matrix. Finally, the processor is to respond to a decoded compress instruction

specifying a compressed destination matrix location, a compression algorithm, and an uncompressed source matrix location comprising the generated result by compressing the specified uncompressed source matrix, and writing the compressed matrix and its associated matrix positions to the specified compressed destination matrix.

[0226] FIG. 21H illustrates execution of a TileCompressOpDecompress instruction, according to some embodiments. As shown, TileCompressOpDecompress instruction 2182 includes fields to specify an opcode 2182A (e.g., TileCompressOpDecompress), a decompressed destination matrix location 2182B, a decompress algorithm 2182C, a decompressed source matrix location 2182D, an arithmetic or logical op 2182E, and a compress algorithm 2182F. Also shown are the specified decompressed source matrix 2184, execution circuitry 2186, which includes compress circuitry, arithmetic or logical operation circuitry, and decompress circuitry, and the specified decompressed destination matrix 2188.

[0227] In operation, a computing system 2180 is to process a TileCompressOpDecompress instruction by responding to a decoded compress instruction specifying a compressed destination matrix location, a compression algorithm, and an uncompressed source matrix location, by compressing the specified uncompressed source matrix, and writing the compressed matrix and its associated matrix positions to the specified compressed destination matrix. The processor is then to generate a result of an operation on the specified compressed destination matrix, and then respond to a decoded decompress instruction specifying a compressed source matrix location being set to the generated result, a decompression algorithm, and a decompressed destination matrix location by copying each element of the specified source matrix to its associated matrix position in the specified destination matrix and zeroing remaining elements of the specified destination matrix.

#### Exemplary Method(s) of Execution

[0228] FIG. 22 illustrates an embodiment of a processor executing a TileCompress instruction. At 2201, the processor is to fetch, using fetch circuitry, a compress instruction specifying a compress algorithm and locations of a decompressed source matrix and a compressed destination matrix. The fetched compress instruction is decoded at 2203. For example, the fetched TileCompress instruction is decoded by decode circuitry such as that detailed herein.

[0229] At 2205, the processor is to respond, using execution circuitry, to the decoded compress instruction by generating a result matrix requiring fewer bits of storage than the specified decompressed source matrix by either packing non-zero-valued elements over zero-valued elements or reducing an average bit size of matrix elements by replacing one or more floating point values with dictionary pointers to a list of floating point values, each dictionary pointer comprising fewer bits than its associated matrix element. In some embodiments, the executed instruction is committed or retired at 2207 which is optional (as indicated by its dashed border) insofar as it may occur at a different time, or not at all.

[0230] FIG. 23 illustrates an embodiment of a processor executing a TileDecompress instruction. At 2301, the processor is to fetch, using fetch circuitry, a decompress instruction having a format with fields to specify an opcode and locations of decompressed source and compressed destina-

tion matrices. The fetched compress instruction is decoded at **2303**. For example, the fetched TileDecompress instruction is decoded by decode circuitry such as that detailed herein, at least at FIG. 13, FIG. 14, and FIGS. 28A-B.

[0231] At **2305**, the processor is to respond, using execution circuitry, to the decoded decompress instruction by generating a compressed result according to a compress algorithm by compressing the specified decompressed source matrix by either packing non-zero-valued elements together and storing the matrix position of each non-zero-valued element in a header, or using fewer bits to represent one or more elements and using the header to identify matrix elements being represented by fewer bits; and storing the compressed result to the specified compressed destination matrix. In some embodiments, the executed instruction is committed or retired at **2307** which is optional (as indicated by its dashed border) insofar as it may occur at a different time, or not at all.

#### Exemplary Instruction Format(s)

[0232] FIG. 24 is a block diagram illustrating a format of a TileCompress/Decompress instruction, according to some embodiments.

[0233] As shown, TileCompress instruction **2402** includes fields for specifying an opcode **2402A**, a compressed destination location **2402B**, a compress algorithm **2402C**, and a decompressed source location **2402D**. Compress algorithm **2402C** is optional, as indicated by its dashed border, insofar as the processor in some embodiments is to use a predetermined default compress algorithm. Source location **2402D** and destination location **2402B** can specify a matrix (tile) in any of a set of vector registers, and a set of tile registers. In some embodiments, the destination specifies a matrix(tile) in memory. Opcode **2402A** is shown including an asterisk, which is to convey that additional prefixes and/or suffixes may be added to specify instruction behavior. In some embodiments, not shown, TileCompress instruction **2402** optionally includes additional fields to specify instruction behavior, including an element size (8b, 16b, 32b, and 64b), source and destination matrix rows (M) and columns (N). A format of TileCompress instruction **2402** is further illustrated and described with respect to FIGS. 25A-B, and FIGS. 26A-D.

[0234] Load decompress and store compress variants of the TileCompress/TileDecompress instruction are expected to be commonly used.

[0235] Also shown, TileDecompress instruction **2412** includes fields for specifying an opcode **2412A**, a decompressed destination location **2412B**, a decompress algorithm **2412C**, and a compressed source location **2412D**. Decompress algorithm **2412C** is optional, as indicated by its dashed border, insofar as the processor in some embodiments is to use a predetermined default decompress algorithm. Source location **2412D** and destination location **2412B** can specify a matrix (tile) in any of a set of vector registers, and a set of tile registers. In some embodiments, the destination specifies a matrix(tile) in memory. Opcode **2412A** is shown including an asterisk, which is to convey that additional prefixes and/or suffixes may be added to specify instruction behavior. In some embodiments, not shown, TileDecompress instruction **2412** optionally includes additional fields to specify instruction behavior, including an element size (8b, 16b, 32b, and 64b), source and destination matrix rows (M) and

columns (N). A format of TileDecompress instruction **2412** is further illustrated and described with respect to FIGS. 25A-B, and FIGS. 26A-D.

[0236] As shown, TileDecompressOpCompress instruction **2422** includes fields for specifying an opcode **2422A**, a compressed destination location **2422B**, a decompress algorithm **2422C**, a compressed source location **2422F**, an arithmetic or logical op **2422E**, and a compress algorithm **2422F**. Source **2422F** and destination location **2422B** can specify a matrix (tile) in any of a set of vector registers, and a set of tile registers. In some embodiments, the destination specifies a matrix(tile) in memory. Opcode **2422A** is shown including an asterisk, which is to convey that additional prefixes and/or suffixes may be added to specify instruction behavior. In some embodiments, not shown, TileDecompressOpCompress instruction **2422** optionally includes additional fields to specify instruction behavior, including an element size (8b, 16b, 32b, and 64b), source and destination matrix rows (M) and columns (N). A format of TileDecompressOpCompress instruction **2422** is further illustrated and described with respect to FIGS. 25A-B, and FIGS. 26A-D.

[0237] As shown, TileCompressOpDecompress instruction **2432** includes fields for specifying an opcode **2432A**, a decompressed destination location **2432B**, a decompress algorithm **2432C**, a decompressed source **2432F**, an arithmetic or logical op **2432E**, and a compress algorithm **2432F**. Source **2432F** and destination location **2432B** can specify a matrix (tile) in any of a set of vector registers, and a set of tile registers. In some embodiments, the destination specifies a matrix(tile) in memory. Opcode **2432A** is shown including an asterisk, which is to convey that additional prefixes and/or suffixes may be added to specify instruction behavior. In some embodiments, not shown, TileCompressOpDecompress instruction **2432** optionally includes additional fields to specify instruction behavior, including an element size (8b, 16b, 32b, and 64b), source and destination matrix rows (M) and columns (N). A format of TileCompressOpDecompress instruction **2432** is further illustrated and described with respect to FIGS. 25A-B, and FIGS. 26A-D.

[0238] Detailed herein are examples of hardware, software, etc. to execute the above described instructions. For example, what is described below details aspects of instruction execution including various pipeline stages such as fetch, decode, schedule, execute, retire, etc.

#### Instruction Sets

[0239] An instruction set may include one or more instruction formats. A given instruction format may define various fields (e.g., number of bits, location of bits) to specify, among other things, the operation to be performed (e.g., opcode) and the operand(s) on which that operation is to be performed and/or other data field(s) (e.g., mask). Some instruction formats are further broken down though the definition of instruction templates (or subformats). For example, the instruction templates of a given instruction format may be defined to have different subsets of the instruction format's fields (the included fields are typically in the same order, but at least some have different bit positions because there are less fields included) and/or defined to have a given field interpreted differently. Thus, each instruction of an ISA is expressed using a given instruction format (and, if defined, in a given one of the instruction templates of that instruction format) and includes fields for specifying the operation and the operands. For

example, an exemplary ADD instruction has a specific opcode and an instruction format that includes an opcode field to specify that opcode and operand fields to select operands (source1/destination and source2); and an occurrence of this ADD instruction in an instruction stream will have specific contents in the operand fields that select specific operands. A set of SIMD extensions referred to as the Advanced Vector Extensions (AVX) (AVX1 and AVX2) and using the Vector Extensions (VEX) coding scheme has been released and/or published (e.g., see Intel® 64 and IA-32 Architectures Software Developer's Manual, September 2014; and see Intel® Advanced Vector Extensions Programming Reference, October 2014).

#### Exemplary Instruction Formats

**[0240]** Embodiments of the instruction(s) described herein may be embodied in different formats. Additionally, exemplary systems, architectures, and pipelines are detailed below. Embodiments of the instruction(s) may be executed on such systems, architectures, and pipelines, but are not limited to those detailed.

**[0241]** Generic Vector Friendly Instruction Format

**[0242]** A vector friendly instruction format is an instruction format that is suited for vector instructions (e.g., there are certain fields specific to vector operations). While embodiments are described in which both vector and scalar operations are supported through the vector friendly instruction format, alternative embodiments use only vector operations the vector friendly instruction format.

**[0243]** FIGS. 25A-25B are block diagrams illustrating a generic vector friendly instruction format and instruction templates thereof according to embodiments. FIG. 25A is a block diagram illustrating a generic vector friendly instruction format and class A instruction templates thereof according to embodiments; while FIG. 25B is a block diagram illustrating the generic vector friendly instruction format and class B instruction templates thereof according to embodiments. Specifically, a generic vector friendly instruction format 2500 for which are defined class A and class B instruction templates, both of which include no memory access 2505 instruction templates and memory access 2520 instruction templates. The term generic in the context of the vector friendly instruction format refers to the instruction format not being tied to any specific instruction set.

**[0244]** While embodiments will be described in which the vector friendly instruction format supports the following: a 64 byte vector operand length (or size) with 32 bit (4 byte) or 64 bit (8 byte) data element widths (or sizes) (and thus, a 64 byte vector consists of either 16 doubleword-size elements or alternatively, 8 quadword-size elements); a 64 byte vector operand length (or size) with 16 bit (2 byte) or 8 bit (1 byte) data element widths (or sizes); a 32 byte vector operand length (or size) with 32 bit (4 byte), 64 bit (8 byte), 16 bit (2 byte), or 8 bit (1 byte) data element widths (or sizes); and a 16 byte vector operand length (or size) with 32 bit (4 byte), 64 bit (8 byte), 16 bit (2 byte), or 8 bit (1 byte) data element widths (or sizes); alternative embodiments may support more, less and/or different vector operand sizes (e.g., 256 byte vector operands) with more, less, or different data element widths (e.g., 128 bit (16 byte) data element widths).

**[0245]** The class A instruction templates in FIG. 25A include: 1) within the no memory access 2505 instruction templates there is shown a no memory access, full round

control type operation 2510 instruction template and a no memory access, data transform type operation 2515 instruction template; and 2) within the memory access 2520 instruction templates there is shown a memory access, temporal 2525 instruction template and a memory access, non-temporal 2530 instruction template. The class B instruction templates in FIG. 25B include: 1) within the no memory access 2505 instruction templates there is shown a no memory access, write mask control, partial round control type operation 2512 instruction template and a no memory access, write mask control, vsize type operation 2517 instruction template; and 2) within the memory access 2520 instruction templates there is shown a memory access, write mask control 2527 instruction template.

**[0246]** The generic vector friendly instruction format 2500 includes the following fields listed below in the order illustrated in FIGS. 25A-25B.

**[0247]** Format field 2540—a specific value (an instruction format identifier value) in this field uniquely identifies the vector friendly instruction format, and thus occurrences of instructions in the vector friendly instruction format in instruction streams. As such, this field is optional in the sense that it is not needed for an instruction set that has only the generic vector friendly instruction format.

**[0248]** Base operation field 2542—its content distinguishes different base operations.

**[0249]** Register index field 2544—its content, directly or through address generation, specifies the locations of the source and destination operands, be they in registers or in memory. These include a sufficient number of bits to select N registers from a P×Q (e.g. 32×512, 16×128, 32×1024, 64×1024) register file. While in one embodiment N may be up to three sources and one destination register, alternative embodiments may support more or less sources and destination registers (e.g., may support up to two sources where one of these sources also acts as the destination, may support up to three sources where one of these sources also acts as the destination, may support up to two sources and one destination).

**[0250]** Modifier field 2546—its content distinguishes occurrences of instructions in the generic vector instruction format that specify memory access from those that do not; that is, between no memory access 2505 instruction templates and memory access 2520 instruction templates. Memory access operations read and/or write to the memory hierarchy (in some cases specifying the source and/or destination addresses using values in registers), while non-memory access operations do not (e.g., the source and destinations are registers). While in one embodiment this field also selects between three different ways to perform memory address calculations, alternative embodiments may support more, less, or different ways to perform memory address calculations.

**[0251]** Augmentation operation field 2550—its content distinguishes which one of a variety of different operations to be performed in addition to the base operation. This field is context specific. In one embodiment, this field is divided into a class field 2568, an alpha field 2552, and a beta field 2554. The augmentation operation field 2550 allows common groups of operations to be performed in a single instruction rather than 2, 3, or 4 instructions.

**[0252]** Scale field 2560—its content allows for the scaling of the index field's content for memory address generation (e.g., for address generation that uses  $2^{scale} * \text{index} + \text{base}$ ).

[0253] Displacement Field **2562A**—its content is used as part of memory address generation (e.g., for address generation that uses  $2^{\text{scale}} \cdot \text{index} + \text{base} + \text{displacement}$ ).

[0254] Displacement Factor Field **2562B** (note that the juxtaposition of displacement field **2562A** directly over displacement factor field **2562B** indicates one or the other is used)—its content is used as part of address generation; it specifies a displacement factor that is to be scaled by the size of a memory access (N)—where N is the number of bytes in the memory access (e.g., for address generation that uses  $2^{\text{scale}} \cdot \text{index} + \text{base} + \text{scaled displacement}$ ). Redundant low-order bits are ignored and hence, the displacement factor field's content is multiplied by the memory operands total size (N) in order to generate the final displacement to be used in calculating an effective address. The value of N is determined by the processor hardware at runtime based on the full opcode field **2574** (described later herein) and the data manipulation field **2554C**. The displacement field **2562A** and the displacement factor field **2562B** are optional in the sense that they are not used for the no memory access **2505** instruction templates and/or different embodiments may implement only one or none of the two.

[0255] Data element width field **2564**—its content distinguishes which one of a number of data element widths is to be used (in some embodiments for all instructions; in other embodiments for only some of the instructions). This field is optional in the sense that it is not needed if only one data element width is supported and/or data element widths are supported using some aspect of the opcodes.

[0256] Write mask field **2570**—its content controls, on a per data element position basis, whether that data element position in the destination vector operand reflects the result of the base operation and augmentation operation. Class A instruction templates support merging-writemasking, while class B instruction templates support both merging- and zeroing-writemasking. When merging, vector masks allow any set of elements in the destination to be protected from updates during the execution of any operation (specified by the base operation and the augmentation operation); in other one embodiment, preserving the old value of each element of the destination where the corresponding mask bit has a 0. In contrast, when zeroing vector masks allow any set of elements in the destination to be zeroed during the execution of any operation (specified by the base operation and the augmentation operation); in one embodiment, an element of the destination is set to 0 when the corresponding mask bit has a 0 value. A subset of this functionality is the ability to control the vector length of the operation being performed (that is, the span of elements being modified, from the first to the last one); however, it is not necessary that the elements that are modified be consecutive. Thus, the write mask field **2570** allows for partial vector operations, including loads, stores, arithmetic, logical, etc. While embodiments are described in which the write mask field's **2570** content selects one of a number of write mask registers that contains the write mask to be used (and thus the write mask field's **2570** content indirectly identifies that masking to be performed), alternative embodiments instead or additional allow the mask write field's **2570** content to directly specify the masking to be performed.

[0257] Immediate field **2572**—its content allows for the specification of an immediate. This field is optional in the sense that it is not present in an implementation of the

generic vector friendly format that does not support immediate and it is not present in instructions that do not use an immediate.

[0258] Class field **2568**—its content distinguishes between different classes of instructions. With reference to FIGS. **25A-B**, the contents of this field select between class A and class B instructions. In FIGS. **25A-B**, rounded corner squares are used to indicate a specific value is present in a field (e.g., class A **2568A** and class B **2568B** for the class field **2568** respectively in FIGS. **25A-B**).

#### Instruction Templates of Class A

[0259] In the case of the non-memory access **2505** instruction templates of class A, the alpha field **2552** is interpreted as an RS field **2552A**, whose content distinguishes which one of the different augmentation operation types are to be performed (e.g., round **2552A.1** and data transform **2552A.2** are respectively specified for the no memory access, round type operation **2510** and the no memory access, data transform type operation **2515** instruction templates), while the beta field **2554** distinguishes which of the operations of the specified type is to be performed. In the no memory access **2505** instruction templates, the scale field **2560**, the displacement field **2562A**, and the displacement scale field **2562B** are not present.

#### No-Memory Access Instruction Templates—Full Round Control Type Operation

[0260] In the no memory access full round control type operation **2510** instruction template, the beta field **2554** is interpreted as a round control field **2554A**, whose content(s) provide static rounding. While in the described embodiments the round control field **2554A** includes a suppress all floating-point exceptions (SAE) field **2556** and a round operation control field **2558**, alternative embodiments may support may encode both these concepts into the same field or only have one or the other of these concepts/fields (e.g., may have only the round operation control field **2558**).

[0261] SAE field **2556**—its content distinguishes whether or not to disable the exception event reporting; when the SAE field's **2556** content indicates suppression is enabled, a given instruction does not report any kind of floating-point exception flag and does not raise any floating-point exception handler.

[0262] Round operation control field **2558**—its content distinguishes which one of a group of rounding operations to perform (e.g., Round-up, Round-down, Round-towards-zero and Round-to-nearest). Thus, the round operation control field **2558** allows for the changing of the rounding mode on a per instruction basis. In one embodiment where a processor includes a control register for specifying rounding modes, the round operation control field's **2550** content overrides that register value.

#### No Memory Access Instruction Templates—Data Transform Type Operation

[0264] In the no memory access data transform type operation **2515** instruction template, the beta field **2554** is interpreted as a data transform field **2554B**, whose content distinguishes which one of a number of data transforms is to be performed (e.g., no data transform, swizzle, broadcast).

[0265] In the case of a memory access **2520** instruction template of class A, the alpha field **2552** is interpreted as an eviction hint field **2552B**, whose content distinguishes

which one of the eviction hints is to be used (in FIG. 25A, temporal 2552B.1 and non-temporal 2552B.2 are respectively specified for the memory access, temporal 2525 instruction template and the memory access, non-temporal 2530 instruction template), while the beta field 2554 is interpreted as a data manipulation field 2554C, whose content distinguishes which one of a number of data manipulation operations (also known as primitives) is to be performed (e.g., no manipulation; broadcast; up conversion of a source; and down conversion of a destination). The memory access 2520 instruction templates include the scale field 2560, and optionally the displacement field 2562A or the displacement scale field 2562B.

[0266] Vector memory instructions perform vector loads from and vector stores to memory, with conversion support. As with regular vector instructions, vector memory instructions transfer data from/to memory in a data element-wise fashion, with the elements that are actually transferred is dictated by the contents of the vector mask that is selected as the write mask.

#### Memory Access Instruction Templates—Temporal

[0267] Temporal data is data likely to be reused soon enough to benefit from caching. This is, however, a hint, and different processors may implement it in different ways, including ignoring the hint entirely.

#### [0268] Memory Access Instruction Templates—Non-Temporal

[0269] Non-temporal data is data unlikely to be reused soon enough to benefit from caching in the 1st-level cache and should be given priority for eviction. This is, however, a hint, and different processors may implement it in different ways, including ignoring the hint entirely.

#### Instruction Templates of Class B

[0270] In the case of the instruction templates of class B, the alpha field 2552 is interpreted as a write mask control (Z) field 2552C, whose content distinguishes whether the write masking controlled by the write mask field 2570 should be a merging or a zeroing.

[0271] In the case of the non-memory access 2505 instruction templates of class B, part of the beta field 2554 is interpreted as an RL field 2557A, whose content distinguishes which one of the different augmentation operation types are to be performed (e.g., round 2557A.1 and vector length (VSIZE) 2557A.2 are respectively specified for the no memory access, write mask control, partial round control type operation 2512 instruction template and the no memory access, write mask control, VSIZE type operation 2517 instruction template), while the rest of the beta field 2554 distinguishes which of the operations of the specified type is to be performed. In the no memory access 2505 instruction templates, the scale field 2560, the displacement field 2562A, and the displacement scale field 2562B are not present.

[0272] In the no memory access, write mask control, partial round control type operation 2510 instruction template, the rest of the beta field 2554 is interpreted as a round operation field 2559A and exception event reporting is disabled (a given instruction does not report any kind of floating-point exception flag and does not raise any floating-point exception handler).

[0273] Round operation control field 2559A—just as round operation control field 2558, its content distinguishes which one of a group of rounding operations to perform (e.g., Round-up, Round-down, Round-towards-zero and Round-to-nearest). Thus, the round operation control field 2559A allows for the changing of the rounding mode on a per instruction basis. In one embodiment where a processor includes a control register for specifying rounding modes, the round operation control field's 2550 content overrides that register value.

[0274] In the no memory access, write mask control, VSIZE type operation 2517 instruction template, the rest of the beta field 2554 is interpreted as a vector length field 2559B, whose content distinguishes which one of a number of data vector lengths is to be performed on (e.g., 128, 256, or 512 byte).

[0275] In the case of a memory access 2520 instruction template of class B, part of the beta field 2554 is interpreted as a broadcast field 2557B, whose content distinguishes whether or not the broadcast type data manipulation operation is to be performed, while the rest of the beta field 2554 is interpreted the vector length field 2559B. The memory access 2520 instruction templates include the scale field 2560, and optionally the displacement field 2562A or the displacement scale field 2562B.

[0276] With regard to the generic vector friendly instruction format 2500, a full opcode field 2574 is shown including the format field 2540, the base operation field 2542, and the data element width field 2564. While one embodiment is shown where the full opcode field 2574 includes all of these fields, the full opcode field 2574 includes less than all of these fields in embodiments that do not support all of them. The full opcode field 2574 provides the operation code (opcode).

[0277] The augmentation operation field 2550, the data element width field 2564, and the write mask field 2570 allow these features to be specified on a per instruction basis in the generic vector friendly instruction format.

[0278] The combination of write mask field and data element width field create typed instructions in that they allow the mask to be applied based on different data element widths.

[0279] The various instruction templates found within class A and class B are beneficial in different situations. In some embodiments, different processors or different cores within a processor may support only class A, only class B, or both classes. For instance, a high performance general purpose out-of-order core intended for general-purpose computing may support only class B, a core intended primarily for graphics and/or scientific (throughput) computing may support only class A, and a core intended for both may support both (of course, a core that has some mix of templates and instructions from both classes is within the purview). Also, a single processor may include multiple cores, all of which support the same class or in which different cores support different class. For instance, in a processor with separate graphics and general-purpose cores, one of the graphics cores intended primarily for graphics and/or scientific computing may support only class A, while one or more of the general-purpose cores may be high performance general purpose cores with out of order execution and register renaming intended for general-purpose computing that support only class B. Another processor that

does not have a separate graphics core, may include one more general purpose in-order or out-of-order cores that support both class A and class B. Of course, features from one class may also be implemented in the other class in different embodiments. Programs written in a high level language would be put (e.g., just in time compiled or statically compiled) into a variety of different executable forms, including: 1) a form having only instructions of the class(es) supported by the target processor for execution; or 2) a form having alternative routines written using different combinations of the instructions of all classes and having control flow code that selects the routines to execute based on the instructions supported by the processor which is currently executing the code.

#### Exemplary Specific Vector Friendly Instruction Format

**[0280]** FIG. 26A is a block diagram illustrating an exemplary specific vector friendly instruction format according to embodiments. FIG. 26A shows a specific vector friendly instruction format **2600** that is specific in the sense that it specifies the location, size, interpretation, and order of the fields, as well as values for some of those fields. The specific vector friendly instruction format **2600** may be used to extend the x86 instruction set, and thus some of the fields are similar or the same as those used in the existing x86 instruction set and extension thereof (e.g., AVX). This format remains consistent with the prefix encoding field, real opcode byte field, MOD R/M field, SIB field, displacement field, and immediate fields of the existing x86 instruction set with extensions. The fields from FIG. 25 into which the fields from FIG. 26A map are illustrated.

**[0281]** It should be understood that, although embodiments are described with reference to the specific vector friendly instruction format **2600** in the context of the generic vector friendly instruction format **2500** for illustrative purposes, the invention is not limited to the specific vector friendly instruction format **2600** except where claimed. For example, the generic vector friendly instruction format **2500** contemplates a variety of possible sizes for the various fields, while the specific vector friendly instruction format **2600** is shown as having fields of specific sizes. By way of specific example, while the data element width field **2564** is illustrated as a one-bit field in the specific vector friendly instruction format **2600**, the invention is not so limited (that is, the generic vector friendly instruction format **2500** contemplates other sizes of the data element width field **2564**).

**[0282]** The generic vector friendly instruction format **2500** includes the following fields listed below in the order illustrated in FIG. 26A.

**[0283]** EVEX Prefix **2602** (Bytes 0-3)—is encoded in a four-byte form.

**[0284]** Format Field **2540** (EVEX Byte 0, bits [7:0])—the first byte (EVEX Byte 0) is the format field **2540** and it contains 0x62 (the unique value used for distinguishing the vector friendly instruction format in one embodiment).

**[0285]** The second-fourth bytes (EVEX Bytes 1-3) include a number of bit fields providing specific capability.

**[0286]** REX field **2605** (EVEX Byte 1, bits [7-5])—consists of an EVEX.R bit field (EVEX Byte 1, bit [7]-R), EVEX.X bit field (EVEX byte 1, bit [6]-X), and 2557BEX byte 1, bit [5]-B). The EVEX.R, EVEX.X, and EVEX.B bit fields provide the same functionality as the corresponding VEX bit fields, and are encoded using is complement form, i.e. ZMM0 is encoded as 1111B, ZMM15 is encoded as

0000B. Other fields of the instructions encode the lower three bits of the register indexes as is known in the art (rrr, xxx, and bbb), so that Rrrr, Xxxx, and Bbbb may be formed by adding EVEX.R, EVEX.X, and EVEX.B.

**[0287]** REX' field **2510**—this is the first part of the REX' field **2510** and is the EVEX.R' bit field (EVEX Byte 1, bit [4]-R') that is used to encode either the upper 16 or lower 16 of the extended 32 register set. In one embodiment, this bit, along with others as indicated below, is stored in bit inverted format to distinguish (in the well-known x86 32-bit mode) from the BOUND instruction, whose real opcode byte is 62, but does not accept in the MOD R/M field (described below) the value of 11 in the MOD field; alternative embodiments do not store this and the other indicated bits below in the inverted format. A value of 1 is used to encode the lower 16 registers. In other words, R'Rrrr is formed by combining EVEX.R', EVEX.R, and the other RRR from other fields.

**[0288]** Opcode map field **2615** (EVEX byte 1, bits [3:0]-mmmm)—its content encodes an implied leading opcode byte (0F, 0F 38, or 0F 3).

**[0289]** Data element width field **2564** (EVEX byte 2, bit [7]-W)—is represented by the notation EVEX.W. EVEX.W is used to define the granularity (size) of the datatype (either 32-bit data elements or 64-bit data elements).

**[0290]** EVEX.vvvv **2620** (EVEX Byte 2, bits [6:3]-vvvv)—the role of EVEX.vvvv may include the following: 1) EVEX.vvvv encodes the first source register operand, specified in inverted (1s complement) form and is valid for instructions with 2 or more source operands; 2) EVEX.vvvv encodes the destination register operand, specified in 1s complement form for certain vector shifts; or 3) EVEX.vvvv does not encode any operand, the field is reserved and should contain 1111b. Thus, EVEX.vvvv field **2620** encodes the 4 low-order bits of the first source register specifier stored in inverted (1s complement) form. Depending on the instruction, an extra different EVEX bit field is used to extend the specifier size to 32 registers.

**[0291]** EVEX.U 2568 Class field (EVEX byte 2, bit [2]-U)—If EVEX.U=0, it indicates class A or EVEX.U0; if EVEX.U=1, it indicates class B or EVEX.U1.

**[0292]** Prefix encoding field **2625** (EVEX byte 2, bits [1:0]-pp)—provides additional bits for the base operation field. In addition to providing support for the legacy SSE instructions in the EVEX prefix format, this also has the benefit of compacting the SIMD prefix (rather than requiring a byte to express the SIMD prefix, the EVEX prefix requires only 2 bits). In one embodiment, to support legacy SSE instructions that use a SIMD prefix (66H, F2H, F3H) in both the legacy format and in the EVEX prefix format, these legacy SIMD prefixes are encoded into the SIMD prefix encoding field; and at runtime are expanded into the legacy SIMD prefix prior to being provided to the decoder's PLA (so the PLA can execute both the legacy and EVEX format of these legacy instructions without modification). Although newer instructions could use the EVEX prefix encoding field's content directly as an opcode extension, certain embodiments expand in a similar fashion for consistency but allow for different meanings to be specified by these legacy SIMD prefixes. An alternative embodiment may redesign the PLA to support the 2-bit SIMD prefix encodings, and thus not require the expansion.

**[0293]** Alpha field **2552** (EVEX byte 3, bit [7]-EH; also known as EVEX.EH, EVEX.rs, EVEX.RL, EVEX.write

mask control, and EVEX.N; also illustrated with  $\alpha$ )—as previously described, this field is context specific.

**[0294]** Beta field **2554** (EVEX byte 3, bits [6:4]-SSS, also known as EVEX.s<sub>2-0</sub>, EVEX.r<sub>2-0</sub>, EVEX.rr1, EVEX.LL0, EVEX.LLb; also illustrated with  $\beta\beta\beta$ )—as previously described, this field is context specific.

**[0295]** REX' field **2510**—this is the remainder of the REX' field and is the EVEX.V' bit field (EVEX Byte 3, bit [3]-V') that may be used to encode either the upper 16 or lower 16 of the extended 32 register set. This bit is stored in bit inverted format. A value of 1 is used to encode the lower 16 registers. In other words, V'VVVV is formed by combining EVEX.V', EVEX.vvvv.

**[0296]** Write mask field **2570** (EVEX byte 3, bits [2:0]-kkk)—its content specifies the index of a register in the write mask registers as previously described. In one embodiment, the specific value EVEX.kkk=000 has a special behavior implying no write mask is used for the particular instruction (this may be implemented in a variety of ways including the use of a write mask hardwired to all ones or hardware that bypasses the masking hardware).

**[0297]** Real Opcode Field **2630** (Byte 4) is also known as the opcode byte. Part of the opcode is specified in this field.

**[0298]** MOD R/M Field **2640** (Byte 5) includes MOD field **2642**, Reg field **2644**, and R/M field **2646**. As previously described, the MOD field's **2642** content distinguishes between memory access and non-memory access operations. The role of Reg field **2644** can be summarized to two situations: encoding either the destination register operand or a source register operand or be treated as an opcode extension and not used to encode any instruction operand. The role of R/M field **2646** may include the following: encoding the instruction operand that references a memory address or encoding either the destination register operand or a source register operand.

**[0299]** Scale, Index, Base (SIB) Byte (Byte 6)—As previously described, the content of SIB **2650** is used for memory address generation. SIB.xxx **2654** and SIB.bbb **2656**—the contents of these fields have been previously referred to with regard to the register indexes Xxxx and Bbbb.

**[0300]** Displacement field **2562A** (Bytes 7-10)—when MOD field **2642** contains 10, bytes 7-10 are the displacement field **2562A**, and it works the same as the legacy 32-bit displacement (disp32) and works at byte granularity.

**[0301]** Displacement factor field **2562B** (Byte 7)—when MOD field **2642** contains 01, byte 7 is the displacement factor field **2562B**. The location of this field is that same as that of the legacy x86 instruction set 8-bit displacement (disp8), which works at byte granularity. Since disp8 is sign extended, it can only address between -128 and 127 bytes offsets; in terms of 64-byte cache lines, disp8 uses 8 bits that can be set to only four really useful values -128, -64, 0, and 64; since a greater range is often needed, disp32 is used; however, disp32 requires 4 bytes. In contrast to disp8 and disp32, the displacement factor field **2562B** is a reinterpretation of disp8; when using displacement factor field **2562B**, the actual displacement is determined by the content of the displacement factor field multiplied by the size of the memory operand access (N). This type of displacement is referred to as disp8\*N. This reduces the average instruction length (a single byte of used for the displacement but with a much greater range). Such compressed displacement assumes that the effective displacement is multiple of the

granularity of the memory access, and hence, the redundant low-order bits of the address offset do not need to be encoded. In other words, the displacement factor field **2562B** substitutes the legacy x86 instruction set 8-bit displacement. Thus, the displacement factor field **2562B** is encoded the same way as an x86 instruction set 8-bit displacement (so no changes in the ModRM/SIB encoding rules) with the only exception that disp8 is overloaded to disp8\*N. In other words, there are no changes in the encoding rules or encoding lengths but only in the interpretation of the displacement value by hardware (which needs to scale the displacement by the size of the memory operand to obtain a byte-wise address offset). Immediate field **2572** operates as previously described.

#### Full Opcode Field

**[0302]** FIG. 26B is a block diagram illustrating the fields of the specific vector friendly instruction format **2600** that make up the full opcode field **2574** according to one embodiment. Specifically, the full opcode field **2574** includes the format field **2540**, the base operation field **2542**, and the data element width (W) field **2564**. The base operation field **2542** includes the prefix encoding field **2625**, the opcode map field **2615**, and the real opcode field **2630**.

#### **[0303]** Register Index Field

**[0304]** FIG. 26C is a block diagram illustrating the fields of the specific vector friendly instruction format **2600** that make up the register index field **2544** according to one embodiment. Specifically, the register index field **2544** includes the REX **2605** field, the REX' **2610** field, the MODR/M.reg field **2644**, the MODR/M.r/m field **2646**, the VVVV field **2620**, xxx field **2654**, and the bbb field **2656**.

#### **[0305]** Augmentation Operation Field

**[0306]** FIG. 26D is a block diagram illustrating the fields of the specific vector friendly instruction format **2600** that make up the augmentation operation field **2550** according to one embodiment. When the class (U) field **2568** contains 0, it signifies EVEX.U0 (class A **2568A**); when it contains 1, it signifies EVEX.U1 (class B **2568B**). When U=0 and the MOD field **2642** contains 11 (signifying a no memory access operation), the alpha field **2552** (EVEX byte 3, bit [7]-EH) is interpreted as the rs field **2552A**. When the rs field **2552A** contains a 1 (round **2552A.1**), the beta field **2554** (EVEX byte 3, bits [6:4]-SSS) is interpreted as the round control field **2554A**. The round control field **2554A** includes a one-bit SAE field **2556** and a two-bit round operation field **2558**. When the rs field **2552A** contains a 0 (data transform **2552A.2**), the beta field **2554** (EVEX byte 3, bits [6:4]-SSS) is interpreted as a three-bit data transform field **2554B**. When U=0 and the MOD field **2642** contains 00, 01, or 10 (signifying a memory access operation), the alpha field **2552** (EVEX byte 3, bit [7]-EH) is interpreted as the eviction hint (EH) field **2552B** and the beta field **2554** (EVEX byte 3, bits [6:4]-SSS) is interpreted as a three bit data manipulation field **2554C**.

**[0307]** When U=1, the alpha field **2552** (EVEX byte 3, bit [7]-EH) is interpreted as the write mask control (Z) field **2552C**. When U=1 and the MOD field **2642** contains 11 (signifying a no memory access operation), part of the beta field **2554** (EVEX byte 3, bit [4]-S<sub>0</sub>) is interpreted as the RL field **2557A**; when it contains a 1 (round **2557A.1**) the rest of the beta field **2554** (EVEX byte 3, bit [6-5]-S<sub>2-1</sub>) is interpreted as the round operation field **2559A**, while when the RL field **2557A** contains a 0 (VSIZE **2557A.2**) the rest



of the beta field **2554** (EVEX byte 3, bit [6-5]-S<sub>2,1</sub>) is interpreted as the vector length field **2559B** (EVEX byte 3, bit [6-5]-L<sub>1,0</sub>). When U=1 and the MOD field **2642** contains 00, 01, or 10 (signifying a memory access operation), the beta field **2554** (EVEX byte 3, bits [6:4]-SSS) is interpreted as the vector length field **2559B** (EVEX byte 3, bit [6-5]-L<sub>1,0</sub>) and the broadcast field **2557B** (EVEX byte 3, bit [4]-B).

### Exemplary Register Architecture

**[0308]** FIG. 27 is a block diagram of a register architecture **2700** according to one embodiment. In the embodiment illustrated, there are 32 vector registers **2710** that are 512 bits wide; these registers are referenced as zmm0 through zmm31. The lower order 256 bits of the lower 16 zmm registers are overlaid on registers ymm0-16. The lower order 128 bits of the lower 16 zmm registers (the lower order 128 bits of the ymm registers) are overlaid on registers xmm0-15. The specific vector friendly instruction format **2600** operates on these overlaid register file as illustrated in the below tables.

Adjustable Vector Length	Class	Operations	Registers
Instruction Templates that do not include the vector length field <b>2559B</b>	A (FIG. 25A; U = 0)	2510, 2515, 2525, 2530	zmm registers (the vector length is 64 byte)
	B (FIG. 25B; U = 1)	2512	zmm registers (the vector length is 64 byte)
Instruction templates that do include the vector length field <b>2559B</b>	B (FIG. 25B; U = 1)	2517, 2527	zmm, ymm, or xmm registers (the vector length is 64-byte, 32 byte, or 16 byte) depending on the vector length field <b>2559B</b>

**[0309]** In other words, the vector length field **2559B** selects between a maximum length and one or more other shorter lengths, where each such shorter length is half the length of the preceding length; and instructions templates without the vector length field **2559B** operate on the maximum vector length. Further, in one embodiment, the class B instruction templates of the specific vector friendly instruction format **2600** operate on packed or scalar single/double-precision floating-point data and packed or scalar integer data. Scalar operations are operations performed on the lowest order data element position in a zmm/ymm/xmm register; the higher order data element positions are either left the same as they were prior to the instruction or zeroed depending on the embodiment.

**[0310]** Write mask registers **2715**—in the embodiment illustrated, there are 8 write mask registers (k0 through k7), each 64 bits in size. In an alternate embodiment, the write mask registers **2715** are 16 bits in size. As previously described, in one embodiment, the vector mask register k0 cannot be used as a write mask; when the encoding that would normally indicate k0 is used for a write mask, it selects a hardwired write mask of 0xFFFF, effectively disabling write masking for that instruction.

**[0311]** General-purpose registers **2725**—in the embodiment illustrated, there are sixteen 64-bit general-purpose registers that are used along with the existing x86 addressing modes to address memory operands. These registers are

referenced by the names RAX, RBX, RCX, RDX, RBP, RSI, RDI, RSP, and R8 through R15.

**[0312]** Scalar floating-point stack register file (x87 stack) **2745**, on which is aliased the MMX packed integer flat register file **2750**—in the embodiment illustrated, the x87 stack is an eight-element stack used to perform scalar floating-point operations on 32/64/80-bit floating-point data using the x87 instruction set extension; while the MMX registers are used to perform operations on 64-bit packed integer data, as well as to hold operands for some operations performed between the MMX and XMM registers.

**[0313]** Alternative embodiments may use wider or narrower registers. Additionally, alternative embodiments may use more, less, or different register files and registers.

**[0314]** Exemplary Core Architectures, Processors, and Computer Architectures

**[0315]** Processor cores may be implemented in different ways, for different purposes, and in different processors. For instance, implementations of such cores may include: 1) a general purpose in-order core intended for general-purpose computing; 2) a high performance general purpose out-of-order core intended for general-purpose computing; 3) a special purpose core intended primarily for graphics and/or scientific (throughput) computing. Implementations of different processors may include: 1) a CPU including one or more general purpose in-order cores intended for general-purpose computing and/or one or more general purpose out-of-order cores intended for general-purpose computing; and 2) a coprocessor including one or more special purpose cores intended primarily for graphics and/or scientific (throughput). Such different processors lead to different computer system architectures, which may include: 1) the coprocessor on a separate chip from the CPU; 2) the coprocessor on a separate die in the same package as a CPU; 3) the coprocessor on the same die as a CPU (in which case, such a coprocessor is sometimes referred to as special purpose logic, such as integrated graphics and/or scientific (throughput) logic, or as special purpose cores); and 4) a system on a chip that may include on the same die the described CPU (sometimes referred to as the application core(s) or application processor(s)), the above described coprocessor, and additional functionality. Exemplary core architectures are described next, followed by descriptions of exemplary processors and computer architectures.

### Exemplary Core Architectures

**[0316]** In-Order and Out-of-Order Core Block Diagram

**[0317]** FIG. 28A is a block diagram illustrating both an exemplary in-order pipeline and an exemplary register renaming, out-of-order issue/execution pipeline according to embodiments. FIG. 28B is a block diagram illustrating both an exemplary embodiment of an in-order architecture core and an exemplary register renaming, out-of-order issue/execution architecture core to be included in a processor according to embodiments. The solid lined boxes in FIGS. 28A-B illustrate the in-order pipeline and in-order core, while the optional addition of the dashed lined boxes illustrates the register renaming, out-of-order issue/execution pipeline and core. Given that the in-order aspect is a subset of the out-of-order aspect, the out-of-order aspect will be described.

**[0318]** In FIG. 28A, a processor pipeline **2800** includes a fetch stage **2802**, a length decode stage **2804**, a decode stage **2806**, an allocation stage **2808**, a renaming stage **2810**, a

scheduling (also known as a dispatch or issue) stage **2812**, a register read/memory read stage **2814**, an execute stage **2816**, a write back/memory write stage **2818**, an exception handling stage **2822**, and a commit stage **2824**.

[0319] FIG. 28B shows processor core **2890** including a front-end unit **2830** coupled to an execution engine unit **2850**, and both are coupled to a memory unit **2870**. The core **2890** may be a reduced instruction set computing (RISC) core, a complex instruction set computing (CISC) core, a very long instruction word (VLIW) core, or a hybrid or alternative core type. As yet another option, the core **2890** may be a special-purpose core, such as, for example, a network or communication core, compression engine, coprocessor core, general purpose computing graphics processing unit (GPGPU) core, graphics core, or the like.

[0320] The front-end unit **2830** includes a branch prediction unit **2832** coupled to an instruction cache unit **2834**, which is coupled to an instruction translation lookaside buffer (TLB) **2836**, which is coupled to an instruction fetch unit **2838**, which is coupled to a decode unit **2840**. The decode unit **2840** (or decoder) may decode instructions, and generate as an output one or more micro-operations, microcode entry points, microinstructions, other instructions, or other control signals, which are decoded from, or which otherwise reflect, or are derived from, the original instructions. The decode unit **2840** may be implemented using various different mechanisms. Examples of suitable mechanisms include, but are not limited to, look-up tables, hardware implementations, programmable logic arrays (PLAs), microcode read only memories (ROMs), etc. In one embodiment, the core **2890** includes a microcode ROM or other medium that stores microcode for certain macroinstructions (e.g., in decode unit **2840** or otherwise within the front-end unit **2830**). The decode unit **2840** is coupled to a rename/allocator unit **2852** in the execution engine unit **2850**.

[0321] The execution engine unit **2850** includes the rename/allocator unit **2852** coupled to a retirement unit **2854** and a set of one or more scheduler unit(s) **2856**. The scheduler unit(s) **2856** represents any number of different schedulers, including reservations stations, central instruction window, etc. The scheduler unit(s) **2856** is coupled to the physical register file(s) unit(s) **2858**. Each of the physical register file(s) units **2858** represents one or more physical register files, different ones of which store one or more different data types, such as scalar integer, scalar floating-point, packed integer, packed floating-point, vector integer, vector floating-point, status (e.g., an instruction pointer that is the address of the next instruction to be executed), etc. In one embodiment, the physical register file(s) unit **2858** comprises a vector registers unit, a write mask registers unit, and a scalar registers unit. These register units may provide architectural vector registers, vector mask registers, and general-purpose registers. The physical register file(s) unit (s) **2858** is overlapped by the retirement unit **2854** to illustrate various ways in which register renaming and out-of-order execution may be implemented (e.g., using a reorder buffer(s) and a retirement register file(s); using a future file(s), a history buffer(s), and a retirement register file(s); using a register maps and a pool of registers; etc.). The retirement unit **2854** and the physical register file(s) unit(s) **2858** are coupled to the execution cluster(s) **2860**. The execution cluster(s) **2860** includes a set of one or more execution units **2862** and a set of one or more memory access units **2864**. The execution units **2862** may perform

various operations (e.g., shifts, addition, subtraction, multiplication) and on various types of data (e.g., scalar floating-point, packed integer, packed floating-point, vector integer, vector floating-point). While some embodiments may include a number of execution units dedicated to specific functions or sets of functions, other embodiments may include only one execution unit or multiple execution units that all perform all functions. The scheduler unit(s) **2856**, physical register file(s) unit(s) **2858**, and execution cluster(s) **2860** are shown as being possibly plural because certain embodiments create separate pipelines for certain types of data/operations (e.g., a scalar integer pipeline, a scalar floating-point/packed integer/packed floating-point/vector integer/vector floating-point pipeline, and/or a memory access pipeline that each have their own scheduler unit, physical register file(s) unit, and/or execution cluster—and in the case of a separate memory access pipeline, certain embodiments are implemented in which only the execution cluster of this pipeline has the memory access unit(s) **2864**). It should also be understood that where separate pipelines are used, one or more of these pipelines may be out-of-order issue/execution and the rest in-order.

[0322] The set of memory access units **2864** is coupled to the memory unit **2870**, which includes a data TLB unit **2872** coupled to a data cache unit **2874** coupled to a level 2 (L2) cache unit **2876**. In one exemplary embodiment, the memory access units **2864** may include a load unit, a store address unit, and a store data unit, each of which is coupled to the data TLB unit **2872** in the memory unit **2870**. The instruction cache unit **2834** is further coupled to a level 2 (L2) cache unit **2876** in the memory unit **2870**. The L2 cache unit **2876** is coupled to one or more other levels of cache and eventually to a main memory.

[0323] By way of example, the exemplary register renaming, out-of-order issue/execution core architecture may implement the pipeline **2800** as follows: 1) the instruction fetch **2838** performs the fetch and length decoding stages **2802** and **2804**; 2) the decode unit **2840** performs the decode stage **2806**; 3) the rename/allocator unit **2852** performs the allocation stage **2808** and renaming stage **2810**; 4) the scheduler unit(s) **2856** performs the schedule stage **2812**; 5) the physical register file(s) unit(s) **2858** and the memory unit **2870** perform the register read/memory read stage **2814**; the execution cluster **2860** perform the execute stage **2816**; 6) the memory unit **2870** and the physical register file(s) unit(s) **2858** perform the write back/memory write stage **2818**; 7) various units may be involved in the exception handling stage **2822**; and 8) the retirement unit **2854** and the physical register file(s) unit(s) **2858** perform the commit stage **2824**.

[0324] The core **2890** may support one or more instructions sets (e.g., the x86 instruction set (with some extensions that have been added with newer versions); the MIPS instruction set of MIPS Technologies of Sunnyvale, Calif.; the ARM instruction set (with optional additional extensions such as NEON) of ARM Holdings of Sunnyvale, Calif.), including the instruction(s) described herein. In one embodiment, the core **2890** includes logic to support a packed data instruction set extension (e.g., AVX1, AVX2), thereby allowing the operations used by many multimedia applications to be performed using packed data.

[0325] It should be understood that the core may support multithreading (executing two or more parallel sets of operations or threads), and may do so in a variety of ways including time sliced multithreading, simultaneous multi-

threading (where a single physical core provides a logical core for each of the threads that physical core is simultaneously multithreading), or a combination thereof (e.g., time sliced fetching and decoding and simultaneous multithreading thereafter such as in the Intel® Hyperthreading technology).

[0326] While register renaming is described in the context of out-of-order execution, it should be understood that register renaming may be used in an in-order architecture. While the illustrated embodiment of the processor also includes separate instruction and data cache units **2834/2874** and a shared L2 cache unit **2876**, alternative embodiments may have a single internal cache for both instructions and data, such as, for example, a Level 1 (L1) internal cache, or multiple levels of internal cache. In some embodiments, the system may include a combination of an internal cache and an external cache that is external to the core and/or the processor. Alternatively, all of the cache may be external to the core and/or the processor.

#### Specific Exemplary In-Order Core Architecture

[0327] FIGS. **29A-B** illustrate a block diagram of a more specific exemplary in-order core architecture, which core would be one of several logic blocks (including other cores of the same type and/or different types) in a chip. The logic blocks communicate through a high-bandwidth interconnect network (e.g., a ring network) with some fixed function logic, memory I/O interfaces, and other necessary I/O logic, depending on the application.

[0328] FIG. **29A** is a block diagram of a single processor core, along with its connection to the on-die interconnect network **2902** and with its local subset of the Level 2 (L2) cache **2904**, according to embodiments. In one embodiment, an instruction decoder **2900** supports the x86 instruction set with a packed data instruction set extension. An L1 cache **2906** allows low-latency accesses to cache memory into the scalar and vector units. While in one embodiment (to simplify the design), a scalar unit **2908** and a vector unit **2910** use separate register sets (respectively, scalar registers **2912** and vector registers **2914**) and data transferred between them is written to memory and then read back in from a level 1 (L1) cache **2906**, alternative embodiments may use a different approach (e.g., use a single register set or include a communication path that allow data to be transferred between the two register files without being written and read back).

[0329] The local subset of the L2 cache **2904** is part of a global L2 cache that is divided into separate local subsets, one per processor core. Each processor core has a direct access path to its own local subset of the L2 cache **2904**. Data read by a processor core is stored in its L2 cache subset **2904** and can be accessed quickly, in parallel with other processor cores accessing their own local L2 cache subsets. Data written by a processor core is stored in its own L2 cache subset **2904** and is flushed from other subsets, if necessary. The ring network ensures coherency for shared data. The ring network is bi-directional to allow agents such as processor cores, L2 caches and other logic blocks to communicate with each other within the chip. Each ring data-path is 1012-bits wide per direction.

[0330] FIG. **29B** is an expanded view of part of the processor core in FIG. **29A** according to embodiments. FIG. **29B** includes an L1 data cache **2906A** part of the L1 cache **2904**, as well as more detail regarding the vector unit **2910**

and the vector registers **2914**. Specifically, the vector unit **2910** is a 16-wide vector processing unit (VPU) (see the 16-wide ALU **2928**), which executes one or more of integer, single-precision float, and double-precision float instructions. The VPU supports swizzling the register inputs with swizzle unit **2920**, numeric conversion with numeric convert units **2922A-B**, and replication with replication unit **2924** on the memory input. Write mask registers **2926** allow predicating resulting vector writes.

[0331] FIG. **30** is a block diagram of a processor **3000** that may have more than one core, may have an integrated memory controller, and may have integrated graphics according to embodiments. The solid lined boxes in FIG. **30** illustrate a processor **3000** with a single core **3002A**, a system agent **3010**, a set of one or more bus controller units **3016**, while the optional addition of the dashed lined boxes illustrates an alternative processor **3000** with multiple cores **3002A-N**, a set of one or more integrated memory controller unit(s) **3014** in the system agent unit **3010**, and special purpose logic **3008**.

[0332] Thus, different implementations of the processor **3000** may include: 1) a CPU with the special purpose logic **3008** being integrated graphics and/or scientific (throughput) logic (which may include one or more cores), and the cores **3002A-N** being one or more general purpose cores (e.g., general purpose in-order cores, general purpose out-of-order cores, a combination of the two); 2) a coprocessor with the cores **3002A-N** being a large number of special purpose cores intended primarily for graphics and/or scientific (throughput); and 3) a coprocessor with the cores **3002A-N** being a large number of general purpose in-order cores. Thus, the processor **3000** may be a general-purpose processor, coprocessor or special-purpose processor, such as, for example, a network or communication processor, compression engine, graphics processor, GPGPU (general purpose graphics processing unit), a high-throughput many integrated core (MIC) coprocessor (including 30 or more cores), embedded processor, or the like. The processor may be implemented on one or more chips. The processor **3000** may be a part of and/or may be implemented on one or more substrates using any of a number of process technologies, such as, for example, BiCMOS, CMOS, or NMOS.

[0333] The memory hierarchy includes one or more levels of cache within the cores, a set or one or more shared cache units **3006**, and external memory (not shown) coupled to the set of integrated memory controller units **3014**. The set of shared cache units **3006** may include one or more mid-level caches, such as level 2 (L2), level 3 (L3), level 4 (L4), or other levels of cache, a last level cache (LLC), and/or combinations thereof. While in one embodiment a ring based interconnect unit **3012** interconnects the special purpose logic **3008** (integrated graphics logic is an example of and is also referred to herein as special purpose logic), the set of shared cache units **3006**, and the system agent unit **3010**/integrated memory controller unit(s) **3014**, alternative embodiments may use any number of well-known techniques for interconnecting such units. In one embodiment, coherency is maintained between one or more cache units **3006** and cores **3002A-N**.

[0334] In some embodiments, one or more of the cores **3002A-N** are capable of multi-threading. The system agent **3010** includes those components coordinating and operating cores **3002A-N**. The system agent unit **3010** may include for example a power control unit (PCU) and a display unit. The

PCU may be or include logic and components needed for regulating the power state of the cores **3002A-N** and the special purpose logic **3008**. The display unit is for driving one or more externally connected displays.

[0335] The cores **3002A-N** may be homogenous or heterogeneous in terms of architecture instruction set; that is, two or more of the cores **3002A-N** may be capable of execution the same instruction set, while others may be capable of executing only a subset of that instruction set or a different instruction set.

[0336] Exemplary Computer Architectures

[0337] FIGS. **31-34** are block diagrams of exemplary computer architectures. Other system designs and configurations known in the arts for laptops, desktops, handheld PCs, personal digital assistants, engineering workstations, servers, network devices, network hubs, switches, embedded processors, digital signal processors (DSPs), graphics devices, video game devices, set-top boxes, micro controllers, cell phones, portable media players, hand held devices, and various other electronic devices, are also suitable. In general, a huge variety of systems or electronic devices capable of incorporating a processor and/or other execution logic as disclosed herein are generally suitable.

[0338] Referring now to FIG. **31**, shown is a block diagram of a system **3100** in accordance with one embodiment of the present invention. The system **3100** may include one or more processors **3110**, **3115**, which are coupled to a controller hub **3120**. In one embodiment the controller hub **3120** includes a graphics memory controller hub (GMCH) **3190** and an Input/Output Hub (IOH) **3150** (which may be on separate chips); the GMCH **3190** includes memory and graphics controllers to which are coupled memory **3140** and a coprocessor **3145**; the IOH **3150** couples input/output (I/O) devices **3160** to the GMCH **3190**. Alternatively, one or both of the memory and graphics controllers are integrated within the processor (as described herein), the memory **3140** and the coprocessor **3145** are coupled directly to the processor **3110**, and the controller hub **3120** in a single chip with the IOH **3150**.

[0339] The optional nature of additional processors **3115** is denoted in FIG. **31** with broken lines. Each processor **3110**, **3115** may include one or more of the processing cores described herein and may be some version of the processor **3000**.

[0340] The memory **3140** may be, for example, dynamic random-access memory (DRAM), phase change memory (PCM), or a combination of the two. For at least one embodiment, the controller hub **3120** communicates with the processor(s) **3110**, **3115** via a multi-drop bus, such as a frontside bus (FSB), point-to-point interface such as Quick-Path Interconnect (QPI), or similar connection **3195**.

[0341] In one embodiment, the coprocessor **3145** is a special-purpose processor, such as, for example, a high-throughput MIC processor, a network or communication processor, compression engine, graphics processor, GPGPU, embedded processor, or the like. In one embodiment, controller hub **3120** may include an integrated graphics accelerator.

[0342] There can be a variety of differences between the physical resources **3110**, **3115** in terms of a spectrum of metrics of merit including architectural, microarchitectural, thermal, power consumption characteristics, and the like.

[0343] In one embodiment, the processor **3110** executes instructions that control data processing operations of a

general type. Embedded within the instructions may be coprocessor instructions. The processor **3110** recognizes these coprocessor instructions as being of a type that should be executed by the attached coprocessor **3145**. Accordingly, the processor **3110** issues these coprocessor instructions (or control signals representing coprocessor instructions) on a coprocessor bus or other interconnect, to coprocessor **3145**. Coprocessor(s) **3145** accept and execute the received coprocessor instructions.

[0344] Referring now to FIG. **32**, shown is a block diagram of a first more specific exemplary system **3200** in accordance with an embodiment of the present invention. As shown in FIG. **32**, multiprocessor system **3200** is a point-to-point interconnect system, and includes a first processor **3270** and a second processor **3280** coupled via a point-to-point interconnect **3250**. Each of processors **3270** and **3280** may be some version of the processor **3000**. In one embodiment, processors **3270** and **3280** are respectively processors **3110** and **3115**, while coprocessor **3238** is coprocessor **3145**. In another embodiment, processors **3270** and **3280** are respectively processor **3110** coprocessor **3145**.

[0345] Processors **3270** and **3280** are shown including integrated memory controller (IMC) units **3272** and **3282**, respectively. Processor **3270** also includes as part of its bus controller units point-to-point (P-P) interfaces **3276** and **3278**; similarly, second processor **3280** includes P-P interfaces **3286** and **3288**. Processors **3270**, **3280** may exchange information via a point-to-point (P-P) interface **3250** using P-P interface circuits **3278**, **3288**. As shown in FIG. **32**, IMCs **3272** and **3282** couple the processors to respective memories, namely a memory **3232** and a memory **3234**, which may be portions of main memory locally attached to the respective processors.

[0346] Processors **3270**, **3280** may each exchange information with a chipset **3290** via individual P-P interfaces **3252**, **3254** using point to point interface circuits **3276**, **3294**, **3286**, **3298**. Chipset **3290** may optionally exchange information with the coprocessor **3238** via a high-performance interface **3292**. In one embodiment, the coprocessor **3238** is a special-purpose processor, such as, for example, a high-throughput MIC processor, a network or communication processor, compression engine, graphics processor, GPGPU, embedded processor, or the like.

[0347] A shared cache (not shown) may be included in either processor or outside of both processors yet connected with the processors via P-P interconnect, such that either or both processors' local cache information may be stored in the shared cache if a processor is placed into a low power mode.

[0348] Chipset **3290** may be coupled to a first bus **3216** via an interface **3296**. In one embodiment, first bus **3216** may be a Peripheral Component Interconnect (PCI) bus, or a bus such as a PCI Express bus or another third generation I/O interconnect bus, although the scope of the present invention is not so limited.

[0349] As shown in FIG. **32**, various I/O devices **3214** may be coupled to first bus **3216**, along with a bus bridge **3218** which couples first bus **3216** to a second bus **3220**. In one embodiment, one or more additional processor(s) **3215**, such as coprocessors, high-throughput MIC processors, GPGPU's, accelerators (such as, e.g., graphics accelerators or digital signal processing (DSP) units), field programmable gate arrays, or any other processor, are coupled to first bus **3216**. In one embodiment, second bus **3220** may be a

low pin count (LPC) bus. Various devices may be coupled to a second bus 3220 including, for example, a keyboard and/or mouse 3222, communication devices 3227 and a storage unit 3228 such as a disk drive or other mass storage device which may include instructions/code and data 3230, in one embodiment. Further, an audio I/O 3224 may be coupled to the second bus 3220. Note that other architectures are possible. For example, instead of the point-to-point architecture of FIG. 32, a system may implement a multi-drop bus or other such architecture.

[0350] Referring now to FIG. 33, shown is a block diagram of a second more specific exemplary system 3300 in accordance with an embodiment of the present invention. Like elements in FIGS. 32 and 33 bear like reference numerals, and certain aspects of FIG. 32 have been omitted from FIG. 33 in order to avoid obscuring other aspects of FIG. 33.

[0351] FIG. 33 illustrates that the processors 3270, 3280 may include integrated memory and I/O control logic (“CL”) 3372 and 3382, respectively. Thus, the CL 3372, 3382 include integrated memory controller units and include I/O control logic. FIG. 33 illustrates that not only are the memories 3232, 3234 coupled to the CL 3372, 3382, but also that I/O devices 3314 are also coupled to the control logic 3372, 3382. Legacy I/O devices 3315 are coupled to the chipset 3290.

[0352] Referring now to FIG. 34, shown is a block diagram of a SoC 3400 in accordance with an embodiment of the present invention. Similar elements in FIG. 30 bear like reference numerals. Also, dashed lined boxes are optional features on more advanced SoCs. In FIG. 34, an interconnect unit(s) 3402 is coupled to: an application processor 3410 which includes a set of one or more cores 3002A-N, which include cache units 3004A-N, and shared cache unit(s) 3006; a system agent unit 3010; a bus controller unit(s) 3016; an integrated memory controller unit(s) 3014; a set of one or more coprocessors 3420 which may include integrated graphics logic, an image processor, an audio processor, and a video processor; an static random access memory (SRAM) unit 3430; a direct memory access (DMA) unit 3432; and a display unit 3440 for coupling to one or more external displays. In one embodiment, the coprocessor(s) 3420 include a special-purpose processor, such as, for example, a network or communication processor, compression engine, GPGPU, a high-throughput MIC processor, embedded processor, or the like.

[0353] Embodiments of the mechanisms disclosed herein may be implemented in hardware, software, firmware, or a combination of such implementation approaches. Embodiments may be implemented as computer programs or program code executing on programmable systems comprising at least one processor, a storage system (including volatile and non-volatile memory and/or storage elements), at least one input device, and at least one output device.

[0354] Program code, such as code 3230 illustrated in FIG. 32, may be applied to input instructions to perform the functions described herein and generate output information. The output information may be applied to one or more output devices, in known fashion. For purposes of this application, a processing system includes any system that has a processor, such as, for example; a digital signal processor (DSP), a microcontroller, an application specific integrated circuit (ASIC), or a microprocessor.

[0355] The program code may be implemented in a high level procedural or object-oriented programming language to communicate with a processing system. The program code may also be implemented in assembly or machine language, if desired. In fact, the mechanisms described herein are not limited in scope to any particular programming language. In any case, the language may be a compiled or interpreted language.

[0356] One or more aspects of at least one embodiment may be implemented by representative instructions stored on a machine-readable medium which represents various logic within the processor, which when read by a machine causes the machine to fabricate logic to perform the techniques described herein. Such representations, known as “IP cores” may be stored on a tangible, machine readable medium and supplied to various customers or manufacturing facilities to load into the fabrication machines that actually make the logic or processor.

[0357] Such machine-readable storage media may include, without limitation, non-transitory, tangible arrangements of articles manufactured or formed by a machine or device, including storage media such as hard disks, any other type of disk including floppy disks, optical disks, compact disk read-only memories (CD-ROMs), compact disk rewritables (CD-RWs), and magneto-optical disks, semiconductor devices such as read-only memories (ROMs), random access memories (RAMs) such as dynamic random access memories (DRAMs), static random access memories (SRAMs), erasable programmable read-only memories (EPROMs), flash memories, electrically erasable programmable read-only memories (EEPROMs), phase change memory (PCM), magnetic or optical cards, or any other type of media suitable for storing electronic instructions.

[0358] Accordingly, embodiments also include non-transitory, tangible machine-readable media containing instructions or containing design data, such as Hardware Description Language (HDL), which defines structures, circuits, apparatuses, processors and/or system features described herein. Such embodiments may also be referred to as program products.

Emulation (Including Binary Translation, Code Morphing, Etc.)

[0359] In some cases, an instruction converter may be used to convert an instruction from a source instruction set to a target instruction set. For example, the instruction converter may translate (e.g., using static binary translation, dynamic binary translation including dynamic compilation), morph, emulate, or otherwise convert an instruction to one or more other instructions to be processed by the core. The instruction converter may be implemented in software, hardware, firmware, or a combination thereof. The instruction converter may be on processor, off processor, or part on and part off processor.

[0360] FIG. 35 is a block diagram contrasting the use of a software instruction converter to convert binary instructions in a source instruction set to binary instructions in a target instruction set according to embodiments. In the illustrated embodiment, the instruction converter is a software instruction converter, although alternatively the instruction converter may be implemented in software, firmware, hardware, or various combinations thereof. FIG. 35 shows a program in a high-level language 3502 may be compiled using an x86

compiler **3504** to generate x86 binary code **3506** that may be natively executed by a processor with at least one x86 instruction set core **3516**. The processor with at least one x86 instruction set core **3516** represents any processor that can perform substantially the same functions as an Intel processor with at least one x86 instruction set core by compatibly executing or otherwise processing (1) a substantial portion of the instruction set of the Intel x86 instruction set core or (2) object code versions of applications or other software targeted to run on an Intel processor with at least one x86 instruction set core, in order to achieve substantially the same result as an Intel processor with at least one x86 instruction set core. The x86 compiler **3504** represents a compiler that is operable to generate x86 binary code **3506** (e.g., object code) that can, with or without additional linkage processing, be executed on the processor with at least one x86 instruction set core **3516**. Similarly, FIG. **35** shows the program in the high level language **3502** may be compiled using an alternative instruction set compiler **3508** to generate alternative instruction set binary code **3510** that may be natively executed by a processor without at least one x86 instruction set core **3514** (e.g., a processor with cores that execute the MIPS instruction set of MIPS Technologies of Sunnyvale, Calif. and/or that execute the ARM instruction set of ARM Holdings of Sunnyvale, Calif.). The instruction converter **3512** is used to convert the x86 binary code **3506** into code that may be natively executed by the processor without an x86 instruction set core **3514**. This converted code is not likely to be the same as the alternative instruction set binary code **3510** because an instruction converter capable of this is difficult to make; however, the converted code will accomplish the general operation and be made up of instructions from the alternative instruction set. Thus, the instruction converter **3512** represents software, firmware, hardware, or a combination thereof that, through emulation, simulation or any other process, allows a processor or other electronic device that does not have an x86 instruction set processor or core to execute the x86 binary code **3506**.

#### FURTHER EXAMPLES

**[0361]** Example 1 provides an exemplary processor comprising: fetch circuitry to fetch a compress instruction having a format with fields to specify an opcode and locations of decompressed source and compressed destination matrices, decode circuitry to decode the fetched compress instructions, and execution circuitry, responsive to the decoded compress instruction, to: generate a compressed result according to a compress algorithm by compressing the specified decompressed source matrix by either packing non-zero-valued elements together and storing the matrix position of each non-zero-valued element in a header, or using fewer bits to represent one or more elements and using the header to identify matrix elements being represented by fewer bits, and store the compressed result to the specified compressed destination matrix.

**[0362]** Example 2 includes the substance of the exemplary processor of Example 1, wherein the execution circuitry is further to perform an arithmetic or logical operation on elements of the compressed result before storing the compressed result to the specified compressed destination matrix.

**[0363]** Example 3 includes the substance of the exemplary processor of Example 1, wherein the specified decompressed source and compressed destination matrices are each

located in any of a collection of floating-point registers, a collection of vector registers, a collection of tile registers, and memory.

**[0364]** Example 4 includes the substance of the exemplary processor of Example 1, wherein: the fetch circuitry is further to fetch a decompress instruction specifying locations of compressed source and decompressed destination matrices, wherein the compressed result is specified as the compressed source matrix, the compressed result having been generated by packing non-zero-valued elements together and storing the matrix position of each non-zero-valued element in the header; the decode circuitry is further to decode the fetched decompress instruction, and the execution circuitry is further to respond to the decoded decompress instruction by writing each of the non-zero-valued elements of the specified compressed source matrix to its associated position within the specified decompressed destination matrix, the associated position being determined by the header.

**[0365]** Example 5 includes the substance of the exemplary processor of Example 1, wherein when the compressed result is generated by packing non-zero-valued elements together, the header comprises a multi-bit value having a bit for each element position of the specified decompressed source matrix, the bit to identify non-zero-valued elements of the decompressed source matrix.

**[0366]** Example 6 includes the substance of the exemplary processor of Example 1, wherein when the compressed result is generated by using fewer bits to represent one or more elements, the header comprises a multi-bit value having a bit for each element position of the specified decompressed source matrix, the bit to identify elements of the compressed result being represented by fewer bits.

**[0367]** Example 7 includes the substance of the exemplary processor of Example 1, wherein when the execution circuitry is to generate the compressed result by using fewer bits to represent one or more elements, the one or more elements are replaced with a pointer to a dictionary of values, the pointer using fewer bits than the specified uncompressed source matrix element.

**[0368]** Example 8 provides an exemplary processor comprising: fetch circuitry to fetch a decompress instruction whose format has fields to specify an opcode and locations of compressed source and decompressed destination matrices, decode circuitry to decode the fetched decompress instructions, and execution circuitry, responsive to the decoded decompress instruction, to: generate a decompressed result according to a decompress algorithm by, when the specified compressed source matrix comprises packed non-zero-valued elements, copying each element of the specified source matrix to its associated position within the specified decompressed destination matrix, the associated position being identified by a multi-bit header having one bit per element of the specified decompressed destination matrix, with bits corresponding to non-zero-valued elements being set, and store the decompressed result to the specified decompressed destination matrix.

**[0369]** Example 9 includes the substance of the exemplary processor of Example 8, wherein the execution circuitry is further to perform an arithmetic or logical operation on elements of the decompressed result before storing the decompressed result to the specified decompressed destination matrix.

**[0370]** Example 10 includes the substance of the exemplary processor of Example 8, wherein the specified compressed source and decompressed destination matrices are each located in any of a collection of floating-point registers, a collection of vector registers, a collection of tile registers, and memory.

**[0371]** Example 11 includes the substance of the exemplary processor of Example 8, wherein: the fetch circuitry is further to fetch a compress instruction specifying locations of decompressed source and compressed destination matrices; wherein the generated decompressed result is specified as the decompressed source matrix, the decode circuitry is further to decode the fetched compress instruction, and the execution circuitry is further to respond to the decoded compress instruction according to a compress algorithm by compressing the specified compressed source matrix by either packing non-zero-valued elements together and storing the matrix position of each non-zero-valued element in a header, or using fewer bits to represent one or more elements and using the header to identify matrix elements being represented by fewer bits.

**[0372]** Example 12 includes the substance of the exemplary processor of Example 8, wherein when the execution circuitry is to generate the compressed result by using fewer bits to represent one or more elements, the one or more elements are replaced with a pointer to a dictionary of values, the pointer using fewer bits than the specified uncompressed source matrix element.

**[0373]** Example 13 provides an exemplary method to be performed by a processor, the processor to: fetch, using fetch circuitry, a compress instruction having a format with fields to specify an opcode and locations of decompressed source and compressed destination matrices, decode, using decode circuitry, the fetched compress instructions, and respond, using execution circuitry, to the decoded compress instruction, by: generating a compressed result according to a compress algorithm by compressing the specified decompressed source matrix by either packing non-zero-valued elements together and storing the matrix position of each non-zero-valued element in a header, or using fewer bits to represent one or more elements and using the header to identify matrix elements being represented by fewer bits, and storing the compressed result to the specified compressed destination matrix.

**[0374]** Example 14 includes the substance of the exemplary method of Example 13, wherein the execution circuitry is further to perform an arithmetic or logical operation on elements of the compressed result before storing the compressed result to the specified compressed destination matrix.

**[0375]** Example 15 includes the substance of the exemplary method of Example 13, wherein the specified decompressed source and compressed destination matrices are each located in any of a collection of floating-point registers, a collection of vector registers, a collection of tile registers, and memory.

**[0376]** Example 16 includes the substance of the exemplary method of Example 13, wherein: the fetch circuitry is further to fetch a decompress instruction specifying locations of compressed source and decompressed destination matrices, wherein the compressed result is specified as the compressed source matrix, the compressed result having been generated by packing non-zero-valued elements together and storing the matrix position of each non-zero-

valued element in the header; the decode circuitry is further to decode the fetched decompress instruction, and the execution circuitry is further to respond to the decoded decompress instruction by writing each of the non-zero-valued elements of the specified compressed source matrix to its associated position within the specified decompressed destination matrix, the associated position being determined by the header.

**[0377]** Example 17 includes the substance of the exemplary method of Example 13, wherein when the compressed result is generated by packing non-zero-valued elements together, the header comprises a multi-bit value having a bit for each element position of the specified decompressed source matrix, the bit to identify non-zero-valued elements of the decompressed source matrix.

**[0378]** Example 18 provides an exemplary non-transitory computer-readable medium containing instructions when executed by a processor, cause the processor to: fetch, using fetch circuitry, a decompress instruction whose format has fields to specify an opcode and locations of compressed source and decompressed destination matrices, decode, using decode circuitry, the fetched decompress instructions, and respond, using execution circuitry, to the decoded decompress instruction, to: generate a decompressed result according to a decompress algorithm by, when the specified compressed source matrix comprises packed non-zero-valued elements, copying each element of the specified source matrix to its associated position within the specified decompressed destination matrix, the associated position being identified by a multi-bit header having one bit per element of the specified decompressed destination matrix, with bits corresponding to non-zero-valued elements being set, and store the decompressed result to the specified decompressed destination matrix.

**[0379]** Example 19 includes the substance of the exemplary non-transitory computer-readable medium of Example 18, wherein the execution circuitry is further to perform an arithmetic or logical operation on elements of the decompressed result before storing the decompressed result to the specified decompressed destination matrix.

**[0380]** Example 20 includes the substance of the exemplary non-transitory computer-readable medium of Example 18, wherein: the fetch circuitry is further to fetch a compress instruction specifying locations of decompressed source and compressed destination matrices; wherein the generated decompressed result is specified as the decompressed source matrix, the decode circuitry is further to decode the fetched compress instruction, and the execution circuitry is further to respond to the decoded compress instruction according to a compress algorithm by compressing the specified compressed source matrix by either packing non-zero-valued elements together and storing the matrix position of each non-zero-valued element in a header, or using fewer bits to represent one or more elements and using the header to identify matrix elements being represented by fewer bits.

What is claimed is:

1. A processor comprising:

fetch circuitry to fetch a single compress instruction having a format with fields to specify an opcode and locations of decompressed source and compressed destination matrices;

decode circuitry to decode the fetched single compress instruction; and

execution circuitry, responsive to the decoded single compress instruction, to:

- generate a compressed result according to a compress algorithm by compressing the specified decompressed source matrix by packing non-zero-valued elements together;
- store a matrix position of each non-zero-valued element in a header; and
- store the compressed result to the specified compressed destination matrix.

2. The processor of claim 1, wherein the execution circuitry is further to perform an arithmetic or logical operation on elements of the compressed result before storing the compressed result to the specified compressed destination matrix.

3. The processor of claim 1, wherein the specified decompressed source and compressed destination matrices are each located in any of a collection of floating-point registers, a collection of vector registers, a collection of tile registers, and memory.

4. The processor of claim 1, wherein:

- the fetch circuitry is further to fetch a single decompress instruction specifying locations of compressed source and decompressed destination matrices, wherein the compressed result is specified as the compressed source matrix;
- the decode circuitry is further to decode the fetched single decompress instruction; and
- the execution circuitry is further to respond to the decoded single decompress instruction by writing each of the non-zero-valued elements of the specified compressed source matrix to its associated position within the specified decompressed destination matrix, the associated position being determined by the header.

5. The processor of claim 1, wherein the header comprises a multi-bit value having a bit for each element position of the specified decompressed source matrix, the bit to identify non-zero-valued elements of the decompressed source matrix.

6. A processor comprising:

- fetch circuitry to fetch a single decompress instruction whose format has fields to specify an opcode and locations of compressed source and decompressed destination matrices;
- decode circuitry to decode the fetched single decompress instruction; and
- execution circuitry, responsive to the decoded single decompress instruction, to:
  - generate a decompressed result according to a decompress algorithm by, when the specified compressed source matrix comprises packed non-zero-valued elements, copying each element of the specified source matrix to its associated position within the specified decompressed destination matrix, the associated position being identified by a header; and
  - store the decompressed result to the specified decompressed destination matrix.

7. The processor of claim 6, wherein the execution circuitry is further to perform an arithmetic or logical operation on elements of the decompressed result before storing the decompressed result to the specified decompressed destination matrix.

8. The processor of claim 6, wherein the specified compressed source and decompressed destination matrices are

each located in any of a collection of floating-point registers, a collection of vector registers, a collection of tile registers, and memory.

9. The processor of claim 6, wherein:

- the fetch circuitry is further to fetch a single compress instruction specifying locations of decompressed source and compressed destination matrices; wherein the generated decompressed result is specified as the decompressed source matrix;

- the decode circuitry is further to decode the fetched single compress instruction; and

- the execution circuitry is further to respond to the decoded single compress instruction according to a compress algorithm by compressing the specified decompressed source matrix by packing non-zero-valued elements together and storing a matrix position of each non-zero-valued element in a header.

10. The processor of claim 6, wherein the header comprises a multi-bit value having a bit for each element position of the specified decompressed destination matrix, the bit to identify non-zero-valued elements of the decompressed destination matrix.

11. A method comprising:

- fetching, using fetch circuitry, a single compress instruction having a format with fields to specify an opcode and locations of decompressed source and compressed destination matrices;

- decoding, using decode circuitry, the fetched single compress instruction; and

- executing, using execution circuitry, the decoded single compress instruction by:

- generating a compressed result according to a compress algorithm by compressing the specified decompressed source matrix by packing non-zero-valued elements together;

- storing a matrix position of each non-zero-valued element in a header; and

- storing the compressed result to the specified compressed destination matrix.

12. The method of claim 11, wherein the executing further comprises performing an arithmetic or logical operation on elements of the compressed result before storing the compressed result to the specified compressed destination matrix.

13. The method of claim 11, wherein the specified decompressed source and compressed destination matrices are each located in any of a collection of floating-point registers, a collection of vector registers, a collection of tile registers, and memory.

14. The method of claim 11, further comprising:

- fetching, using the fetch circuitry, a single decompress instruction specifying locations of compressed source and decompressed destination matrices, wherein the compressed result is specified as the compressed source matrix;

- decoding, using the decode circuitry, the fetched single decompress instruction; and

- executing, using the execution circuitry, the decoded single decompress instruction by writing each of the non-zero-valued elements of the specified compressed source matrix to its associated position within the specified decompressed destination matrix, the associated position being determined by the header.



**15.** The method of claim **11**, wherein the header comprises a multi-bit value having a bit for each element position of the specified decompressed source matrix, the bit to identify non-zero-valued elements of the decompressed source matrix.

**16.** A method comprising:

fetching, using fetch circuitry, a single decompress instruction whose format has fields to specify an opcode and locations of compressed source and decompressed destination matrices;

decoding, using decode circuitry, the fetched single decompress instruction; and

executing, using execution circuitry, the decoded single decompress instruction by:

generating a decompressed result according to a decompress algorithm by, when the specified compressed source matrix comprises packed non-zero-valued elements, copying each element of the specified source matrix to its associated position within the specified decompressed destination matrix, the associated position being identified by a header; and storing the decompressed result to the specified decompressed destination matrix.

**17.** The method of claim **16**, wherein the executing further comprises performing an arithmetic or logical operation on elements of the decompressed result before storing the decompressed result to the specified decompressed destination matrix.

**18.** The method of claim **16**, wherein the specified compressed source and decompressed destination matrices are each located in any of a collection of floating-point registers, a collection of vector registers, a collection of tile registers, and memory.

**19.** The method of claim **16**, further comprising:

fetching, using the fetch circuitry, a single compress instruction specifying locations of decompressed source and compressed destination matrices; wherein the generated decompressed result is specified as the decompressed source matrix;

decoding, using the decode circuitry, the fetched single compress instruction; and

executing, using the execution circuitry, the decoded single compress instruction according to a compress algorithm by compressing the specified decompressed source matrix by packing non-zero-valued elements together and storing a matrix position of each non-zero-valued element in a header.

**20.** The method of claim **16**, wherein the header comprises a multi-bit value having a bit for each element position of the specified decompressed destination matrix, the bit to identify non-zero-valued elements of the decompressed destination matrix.

\* \* \* \* \*