



US006068454A

United States Patent [19]
Gaston et al.

[11] **Patent Number:** **6,068,454**
[45] **Date of Patent:** **May 30, 2000**

[54] **FUEL PUMP WITH HELICAL IMPELLER**

[75] Inventors: **Robert Duane Gaston**, Dearborn Heights; **Beverly Jane Wozniak**, Livonia; **Dequan Yu**, Ann Arbor, all of Mich.

[73] Assignee: **Ford Motor Company**, Dearborn, Mich.

[21] Appl. No.: **09/055,427**

[22] Filed: **Apr. 6, 1998**

[51] **Int. Cl.⁷** **F04B 17/00**

[52] **U.S. Cl.** **417/356; 417/423.7; 417/177; 417/241 A**

[58] **Field of Search** **417/356, 423.3, 417/423.7, 424.1; 415/72; 416/126, 127, 241 A, 235, 237, 244 R, 204 R**

[56] **References Cited**

U.S. PATENT DOCUMENTS

1,762,708	6/1930	Allred .	
2,195,902	4/1940	Pezzillo	417/356
2,225,338	12/1940	Geiss .	
3,236,221	2/1966	Lear .	
3,565,548	2/1971	Fowler et al.	416/235
4,876,492	10/1989	Lester et al.	417/356

4,998,865	3/1991	Nakanishi et al. .	
5,088,899	2/1992	Blecker et al.	417/356
5,145,329	9/1992	Zumbusch et al. .	
5,324,177	6/1994	Golding et al. .	
5,487,650	1/1996	Gaston et al.	417/423.6
5,505,594	4/1996	Sheehan .	

FOREIGN PATENT DOCUMENTS

0452538 A1	10/1991	European Pat. Off. .
1781462 A1	12/1992	Russian Federation .

Primary Examiner—Charles G. Freay
Attorney, Agent, or Firm—Mark S. Sparshu

[57] **ABSTRACT**

A fuel pump is used for supplying fuel from a fuel tank to an automotive engine. The fuel pump includes a pump housing having an inlet end for receiving fuel from the fuel tank. A brushless DC motor is positioned within the pump housing and includes a rotatable rotor having magnets therein and a central aperture formed through the rotor. A plastic helical-shaped impeller is positioned within the central aperture for rotation with the rotor about a central axis for pumping fuel through the housing to the engine. The impeller has a plurality of vane blades with blade tips secured to the rotor to prevent tip losses. Each vane blade has a leading edge configured to generate laminar fluid flow and reduce vapor generation at the inlet end of the impeller.

11 Claims, 4 Drawing Sheets

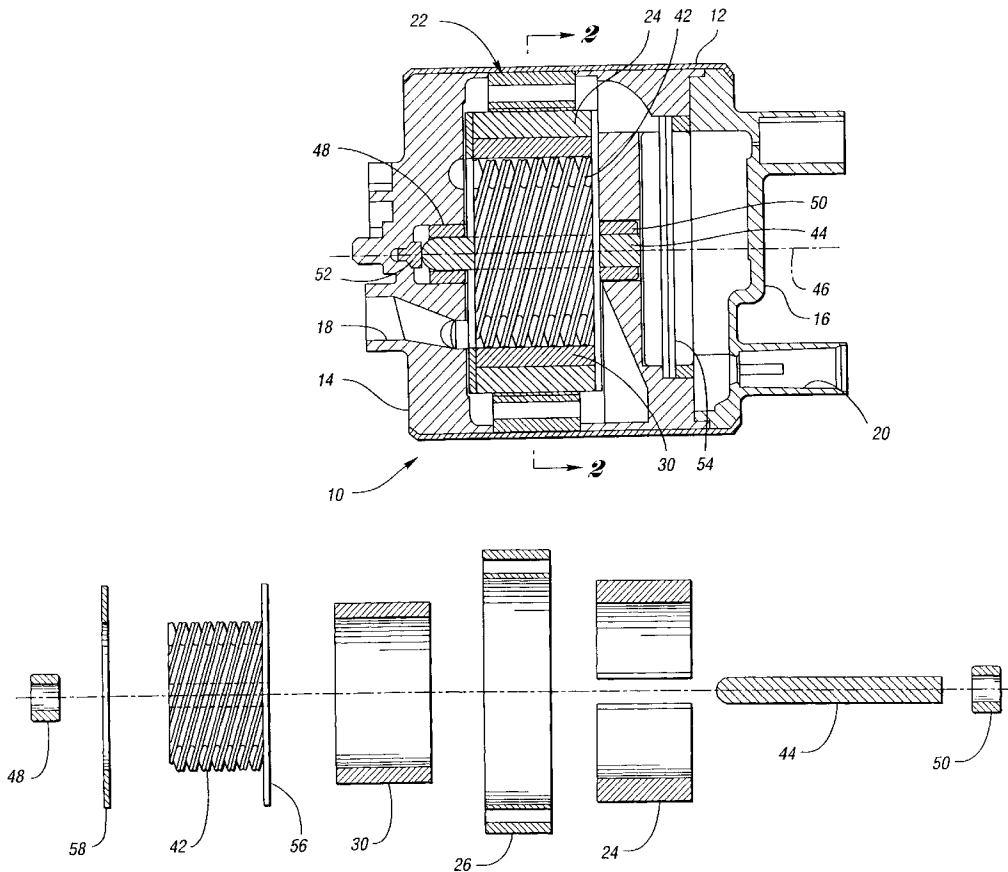

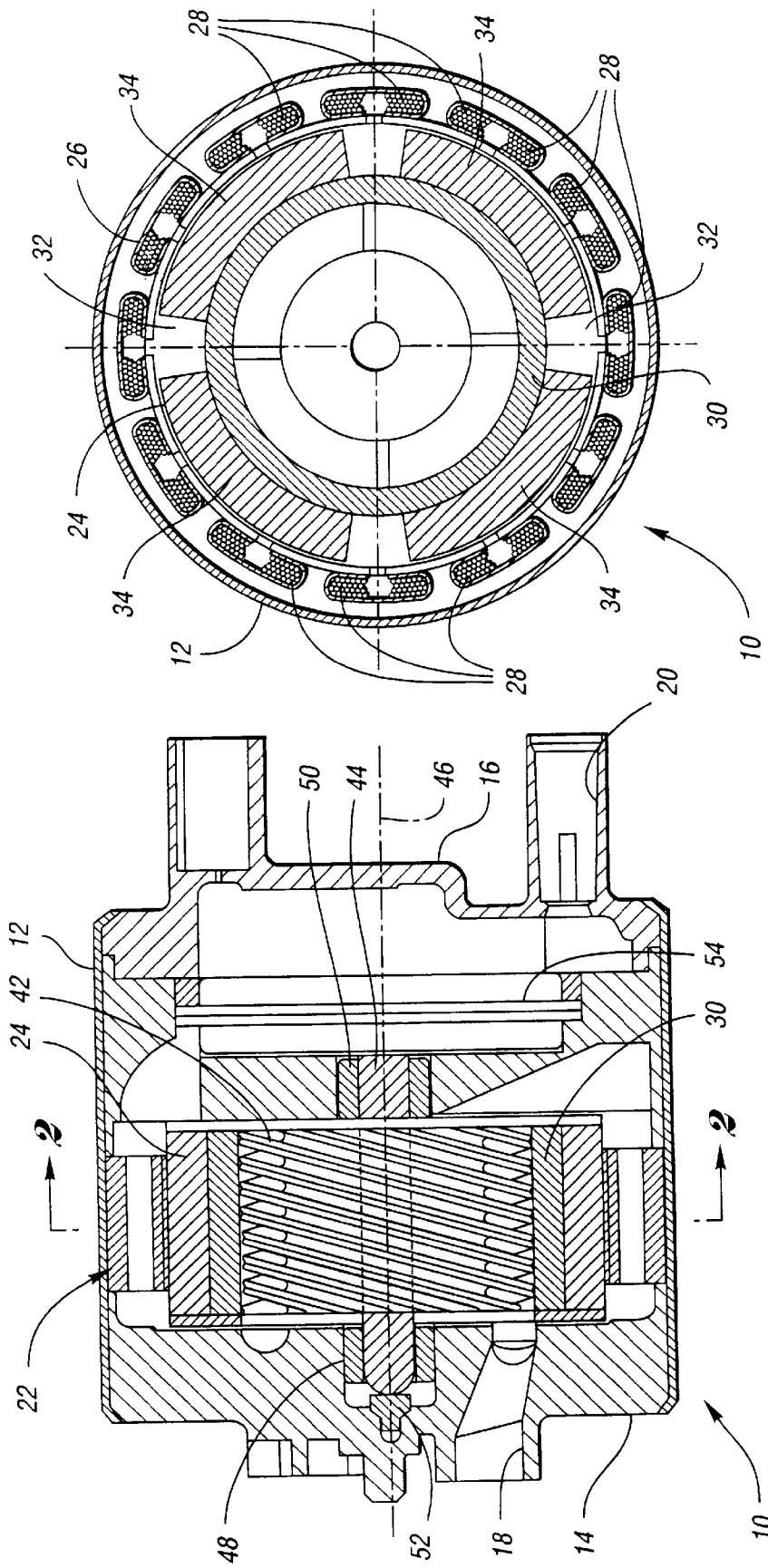

Fig. 2

Fig. 1

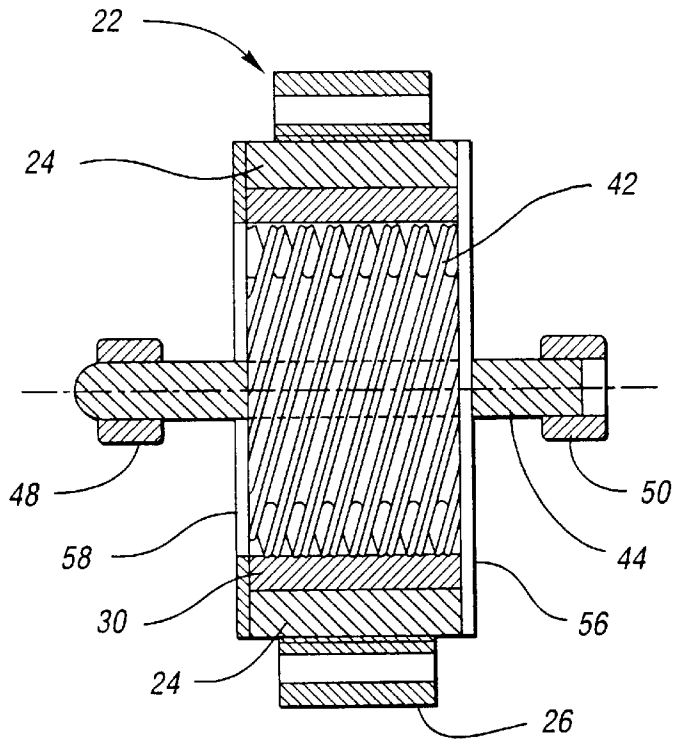

Fig. 3

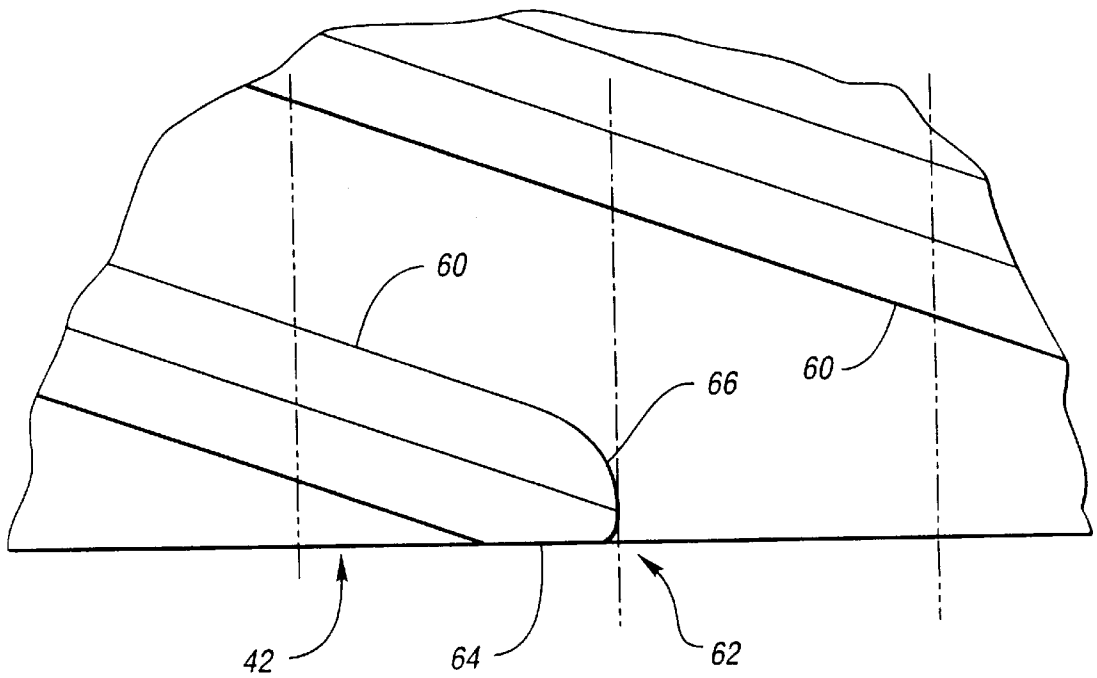

Fig. 9

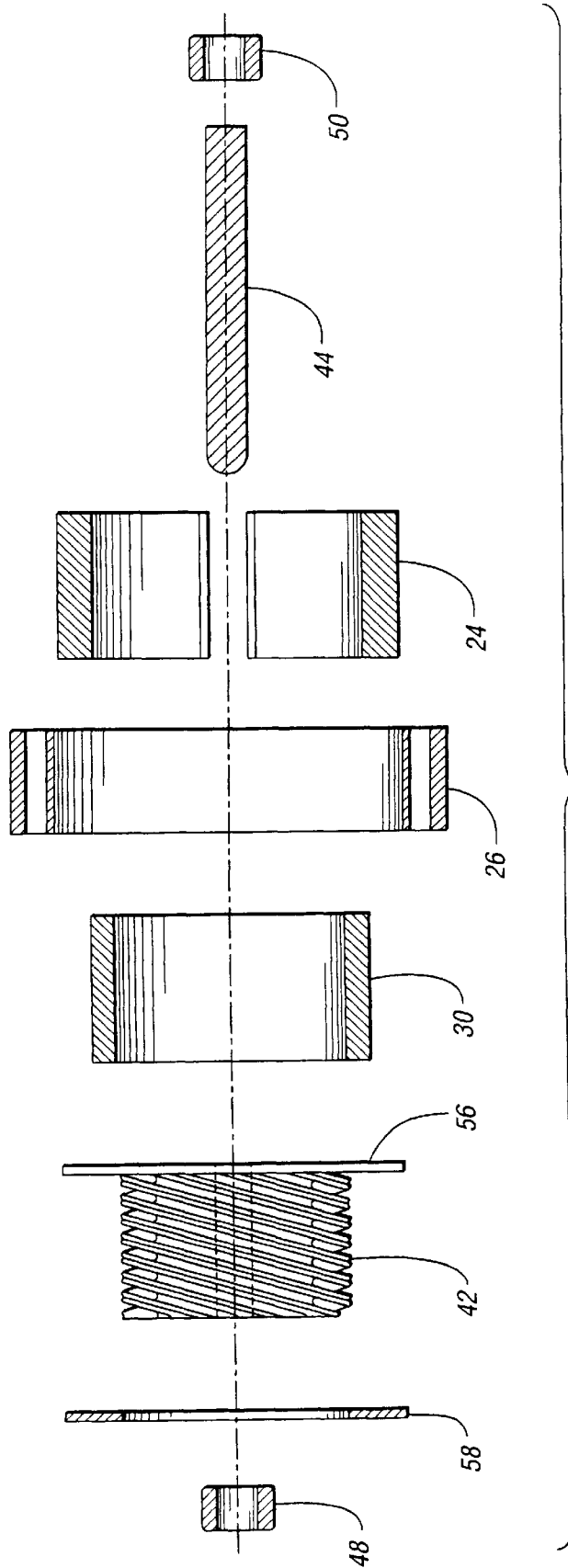

Fig. 4

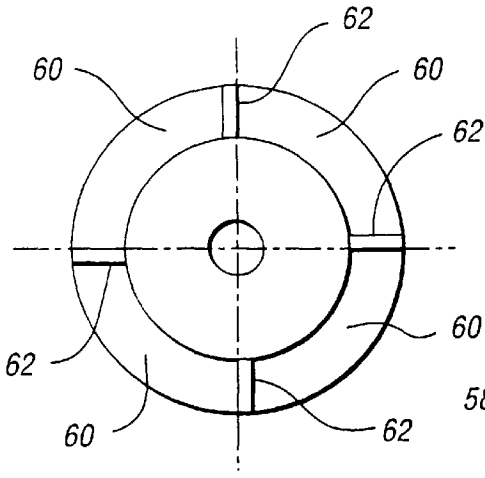

Fig. 6

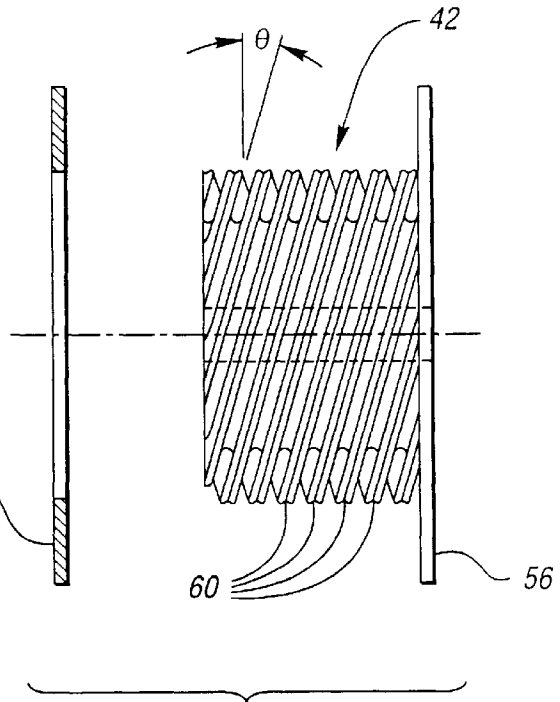

Fig. 5

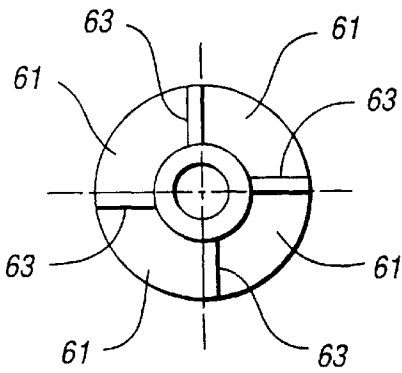

Fig. 8

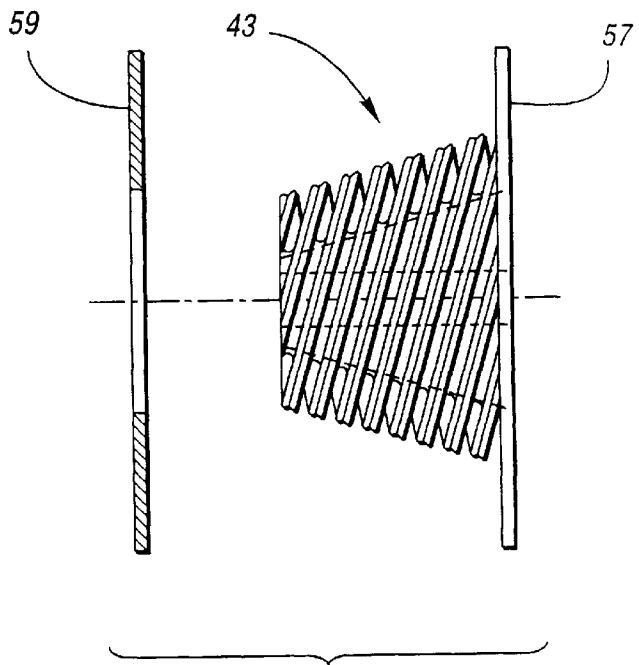

Fig. 7

FUEL PUMP WITH HELICAL IMPELLER**TECHNICAL FIELD**

The present invention relates to a fuel pump and, more particularly, to a fuel pump having a brushless DC motor with an integrated helical impeller.

BACKGROUND OF THE INVENTION

In the early 1990s, ethanol and methanol blends of alcohol gasoline were developed to reduce the amount of hydrocarbons spilled into the air from incomplete combustion during burning of gasoline in automobiles and light trucks. These fuels were found to be corrosive to certain iron, copper, silver, and aluminum bearing alloys contained in fuel pumps which were positioned within the fuel tank. As a result of this corrosive action, automotive engineers have shifted to the use of plastics, carbons, and polymers for fuel pump components due to their resistance to corrosion from alcohol fuels.

More recently, there is a movement toward placing electric in-tank fuel pumps in the fuel tank for transport of diesel fuel to the engine rather than using vacuum created by an engine driven fuel pump. During the development of the initial in-tank or in-line fuel pumps, it was discovered that diesel fuel was corrosive to DC carbon brushes and experimentation has led to the use of special carbon-laden brushes and carbon-covered commutations.

Vehicle design trends toward lower profile overall body designs have resulted in very shallow fuel tanks. This design requirement causes difficulty in packaging of existing fuel pumps in shallow tanks. Current fuel pumps typically have a 38 millimeter diameter and are 110 to 120 millimeters in axial length. Accordingly, difficulties arise in packaging such a long pump in a fuel tank which may only be 120 millimeters deep.

Other design factors leading to the development of the present invention include: 1) the cost of machined aluminum pump chamber bodies and covers; 2) the cost of carbon-covered commutators and longer life carbon alloy brushes; 3) the use of round commutators versus flat, placing the brushes perpendicular to the pump axis to reduce pump axial length; and 4) increased pump-motor diameter to increase motor efficiency and lower system current, while reducing pump axial length.

Accordingly, it is desirable to provide an in-tank or in-line fuel pump with substantially reduced axial length which takes in consideration the above-referenced design factors.

DISCLOSURE OF THE INVENTION

The present invention overcomes the above-referenced shortcomings of prior art in-tank or in-line fuel pumps by providing an in-tank or in-line fuel pump having a brushless DC motor including a rotatable rotor having a plastic helical-shaped impeller positioned within the rotor for pumping fuel from the fuel tank to an automotive engine. By positioning the impeller within the DC motor, the axial length of the impeller is reduced by approximately 67% for use in low profile fuel tanks. By using a helical impeller embedded within the motor rotor, blade tip losses are eliminated. The design also provides corrosive fuel compatible materials.

More specifically, the present invention provides a fuel pump for supplying fuel from a fuel tank to an automotive engine, including a pump housing having an inlet end for receiving fuel from the fuel tank. A brushless DC motor is

positioned within the pump housing and includes a rotatable rotor having magnets therein and a central aperture formed through the rotor. A plastic helical-shaped impeller is positioned within the central aperture for rotation with the rotor about a central axis for pumping fuel through the housing to the engine. The impeller includes a plurality of vane blades with blade tips secured to the rotor to eliminate blade tip losses.

In a preferred embodiment, each vane blade has a leading edge formed at an inlet end of the impeller. Each leading edge has a flat portion formed perpendicular to the central axis of the impeller, and a curved nose portion extending from the flat portion for generating laminar fluid flow and reducing vapor generation at the inlet end of the impeller.

Preferably, the impeller has an integrally molded cap at an outlet end of the impeller which is engaged against the rotor to prevent axial movement of the impeller through the rotor as a result of forces generated by pressurized fuel at the outlet end.

Accordingly, an object of the present invention is to provide a fuel pump having a substantially reduced axial length without loss of pump efficiency for in-tank or in-line use.

Another object of the invention is to provide a fuel pump having an impeller with a leading edge with a flat portion perpendicular to the central axis of the impeller and a curved nose portion extending from the flat portion for generating laminar fluid flow.

The above objects and other objects, features and advantages of the present invention are readily apparent from the following detailed description of the best mode for carrying out the invention when taken in connection with the accompanying drawings.

BRIEF DESCRIPTION OF THE DRAWINGS

FIG. 1 shows a longitudinal cross-sectional view of a fuel pump in accordance with the present invention;

FIG. 2 shows a vertical cross-sectional view of the fuel pump of FIG. 1 taken at line 2—2;

FIG. 3 shows a cross-sectional view of a DC brushless motor and impeller in accordance with the embodiment of FIG. 1;

FIG. 4 shows an exploded cross-sectional side view of a DC brushless motor and impeller in accordance with the embodiment of FIG. 1;

FIG. 5 shows an exploded side view of an impeller in accordance with the embodiment of FIG. 1;

FIG. 6 shows an end view of the inlet end of the impeller of FIG. 6;

FIG. 7 shows an exploded side view of an impeller in accordance with an alternative embodiment of the invention;

FIG. 8 shows an end view of the inlet end of the impeller of FIG. 8; and

FIG. 9 shows an enlarged side view of the inlet end of the impeller of FIG. 6.

DETAILED DESCRIPTION OF THE PREFERRED EMBODIMENT

Referring to FIGS. 1 and 2, a fuel pump 10 is shown for supplying fuel from a fuel tank to an automotive engine. The fuel pump 10 includes a steel pump housing 12 having an inlet cover 14 and an outlet cover 16 at opposing ends of the housing 12. The inlet cover 14 has an inlet opening 18 for receiving fuel from the lowest part of the fuel tank, and the

outlet cover **16** includes a fuel outlet opening **20** for directing fuel to the vehicle engine.

A brushless DC motor **22** is positioned within the pump housing **12** and includes a rotatable rotor **24** which is rotatable within the stator **26**, which is a series of stacked laminations. The stator **26** includes three sets of windings **28** wrapped in 12 slots around the periphery of the laminations. Preferably, a 0.64 mm air gap is provided between the stator **26** and the rotor **24**. The rotor **24** includes an iron core **30** with a plastic filler **32** and a plurality of magnets **34, 36, 38, 40** therearound. The magnets are operative to boost the flux across the air gap.

A plastic helical-shaped impeller **42** is positioned within the iron core **30** for rotation with the rotor **24**. The impeller **42** is rotatable on a central shaft **44** about a central axis **46**. Bearings **48,50** are provided at opposing ends of the central shaft **44**, and a thrust button **52** abuts the shaft **44** to maintain the position of the shaft **44**. With the impeller **42** embedded in the rotor **24**, blade tip losses are eliminated at the ends of the vane blades of the impeller **42**.

Preferably, the impeller **42**, as well as the inlet cover **14** and outlet cover **16**, comprises a plastic material, such as acetyl or phenolic, to avoid corrosion.

The rotating impeller **42** draws fuel in through the inlet opening **18** into the four-bladed impeller **42**, through the impeller **42**, around the periphery of the electronics module **54**, and through the outlet opening **20** to the engine. The electronics module **54** may be round or square, as a matter of design choice.

The brushless DC motor **22** is more clearly shown in FIGS. **3** and **4**. As shown, the impeller **42** has an integrally molded end cap **56** at the outlet end, and an adhered end cap **58** at the inlet end. The integrally molded end cap **56** bears against the rotor **24** to prevent movement of the impeller through the rotor **24** as a result of fuel pressure generated at the outlet end of the impeller **42**.

As shown in FIG. **5**, the vane blades **60** of the impeller **42** have an angle θ of approximately 16° , but may range from approximately 14° to 16° . The end view of FIG. **6** illustrates the fact that the impeller **42** has four equally spaced helical vane blades **60**, each having a leading edge **62**.

Referring to FIGS. **7** and **8**, an alternative impeller **43** is shown. The impeller **43** has a conical peripheral shape, and includes an integrally molded end cap **57** and an adhered end cap **59**. The peripheral shape of the impeller **43** is a matter of design choice and may be used to optimize pump efficiency. As shown in FIG. **8**, the impeller **43** comprises four vane blades **61** with leading edges **63**.

As shown in FIG. **9**, each leading edge **62** comprises a flat portion **64** formed perpendicular to the central axis **46** and a curved nose portion **66** extending from the flat portion **64** for generating laminar fluid flow and reducing vapor generation at the inlet of the impeller **42** by avoiding sudden increase of pressure to prevent inlet cavitation. The flat portion **64** is machined to assure true flatness of the impeller and rotor at the inlet. The depth of the inlet opening **18** may vary to produce more efficient flow characteristics. Fuel from the helical impeller **42** is used to cool the electronic commutation module and is circulated past the outer motor core for cooling purposes. The electronic module carrier **54** may be used as a termination component and as a fuel direction diffuser to gain an increment of pressure.

By increasing the outside diameter of the pump to 50–55 mm, the present invention improves pump efficiency, allows incorporation of the impeller **42** within the rotor **24** to provide a substantially reduced axial length (preferably 58 to

62 mm in axial length), and as pressure demands increase, the motor and impeller **42** may be lengthened and still be practical for use in lower profile fuel tanks. The brushless motor is very useful in corrosive fuel environments, such as diesel and high-alcohol content fuels.

While the best mode for carrying out the invention has been described in detail, those familiar with the art to which this invention relates will recognize various alternative designs and embodiments for practicing the invention within the scope of the appended claims.

What is claimed is:

1. A fuel pump for supplying fuel from a fuel tank to an automotive engine, the fuel pump comprising:

a pump housing having an inlet end for receiving fuel from the fuel tank;

a brushless DC motor positioned within the pump housing and including a rotatable rotor having magnets therein and a central aperture formed through the rotor;

a plastic helical-shaped impeller positioned within said central aperture for rotation with the rotor about a central axis for pumping fuel through the housing to the engine, said impeller having a plurality of vane blades with blade tips secured to the rotor; and

wherein said impeller comprises an integrally molded cap at an outlet end of the impeller for engagement against the rotor to prevent axial movement of the impeller through the rotor as a result of forces generated by pressurized fuel at said outlet end.

2. The fuel pump of claim **1**, wherein each said vane blade comprises a leading edge formed at an inlet end of the impeller, each said leading edge comprising a flat portion formed perpendicular to said central axis, and a curved nose portion extending from said flat portion for generating laminar fluid flow and reducing vapor generation at the inlet end of the impeller.

3. The fuel pump of claim **1**, wherein each said vane blade comprises an inclination angle of approximately 14° to 18° with respect to a plane perpendicular to said central axis.

4. The fuel pump of claim **1**, further comprising an adhered cap secured to the inlet end of the impeller for engagement against the rotor.

5. The fuel pump of claim **1**, wherein said plurality of vane blades comprises four vane blades spaced equally about the impeller.

6. A fuel pump for supplying fuel from a fuel tank to an automotive engine, the fuel pump comprising:

a pump housing having an inlet end for receiving fuel from the fuel tank;

a brushless DC motor positioned within the pump housing and including a rotatable rotor having magnets therein and a central aperture formed through the rotor;

a plastic helical-shaped impeller positioned within said central aperture for rotation with the impeller along a central axis for pumping fuel through the housing to the engine, said rotor having a plurality of vane blades with blade tips secured to the rotor; and

wherein each said vane blade comprises a leading edge formed at an inlet end of the impeller, each said leading edge comprising a flat portion formed perpendicular to said central axis, and a curved nose portion extending from said flat portion for generating laminar fluid flow and reducing vapor generation at the inlet end of the impeller.

7. The fuel pump of claim **6**, wherein each said vane blade comprises an inclination angle of approximately 14° to 18° with respect to a plane perpendicular to said central axis.

5

8. The fuel pump of claim 6, wherein said impeller comprises an integrally molded cap at an outlet end of the impeller for engagement against the rotor to prevent axial movement of the impeller through the rotor as a result of forces generated by pressurized fuel at said outlet end. 5

9. The fuel pump of claim 8, further comprising an adhered cap secured to the inlet end of the impeller for engagement against the rotor.

10. The fuel pump of claim 6, wherein said plurality of vane blades comprises four vane blades spaced equally 10 about the impeller.

11. A fuel pump for supplying fuel from a fuel tank to an automotive engine, the fuel pump comprising:

a pump housing having an inlet end for receiving fuel from the fuel tank;

6

a brushless DC motor positioned within the pump housing and including a rotatable rotor having magnets therein and a central aperture formed through the rotor;

a plastic helical-shaped impeller positioned within said central aperture for rotation with the rotor about a central axis for pumping fuel through the housing to the engine, said impeller having a plurality of vane blades with blade tips secured to the rotor; and

wherein said impeller comprises an integrally molded cap at an outlet end of the impeller for engagement against the rotor to prevent axial movement of the impeller through the rotor as a result of forces generated by pressurized fuel at said outlet end.

* * * * *