

(43) Date of A Publication 01.12.1999

(21) Application No 9827389.9
 (22) Date of Filing 11.12.1998
 (30) Priority Data
 (31) 98019695 (32) 29.05.1998 (33) KR

(71) Applicant(s)
Daewoo Electronics Co., Ltd.
(Incorporated in the Republic of Korea)
541 5-Ga Namdaemoon-Ro, Jung-Gu, Seoul 100-095,
Republic of Korea

(72) Inventor(s)
Tae-Beom Lim

(74) Agent and/or Address for Service
Page White & Farrer
54 Doughty Street, LONDON, WC1N 2LS,
United Kingdom

(51) INT CL⁶
H04N 7/173

(52) UK CL (Edition Q.)
H4R RCSS R17D R17U

(56) Documents Cited
GB 2317082 A EP 0726535 A1 EP 0653886 A1
US 5561456 A

(58) Field of Search
 UK CL (Edition Q.) H4R RCS RCSS RCT RCX
 INT CL⁶ H04N 7/173
ONLINE - EPODOC, WPI

(54) Abstract Title
Video on demand system with adaptively controlled response stand-by time

(57) In a video on demand system in which users requesting the same program within a certain time interval, called the response stand-by time (RSBT), are provided with that program simultaneously as a group when that interval has expired, the duration of the response stand-by time (RSBT) interval is adaptively controlled depending on the number of requests made for the corresponding program in the previous (ie. most recently expired) interval. In response to a service demand signal from a user requesting the corresponding program, a program group search request signal for that program is generated 306, a program group for the corresponding program is decided 307 from stored data, and a count NDT of the number of such decisions is made 308 until the RSBT interval expires 309. The duration of the RSBT for the current interval is changed if the current NDT count (that is the NDT count made over the previous RSBT interval) meets certain criteria. The RSBT may be changed if the current NDT (for the previous RSBT) is outside a predetermined range, which range is different for different RSBT durations. Alternatively, the RSBT may be changed if $CRV < \alpha PRV$ or if $CRV > \beta PRV$, where CRV is a current reference value = (current NDT/previous RSBT), PRV is a previous reference value = (previous NDT/previous RSBT), $\alpha < 1$ and $\beta > 1$.

FIG. 3A

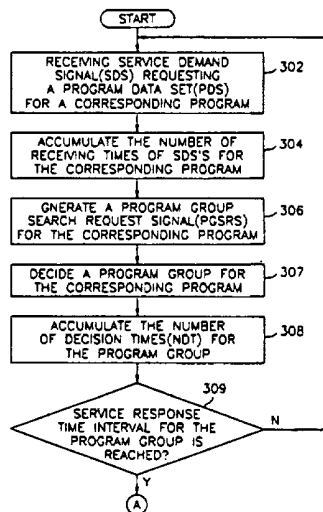

FIG. 3B

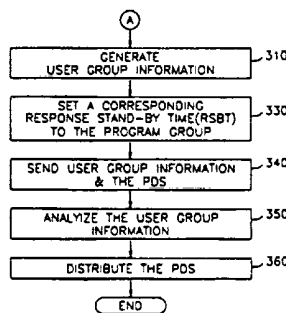

FIG. 1

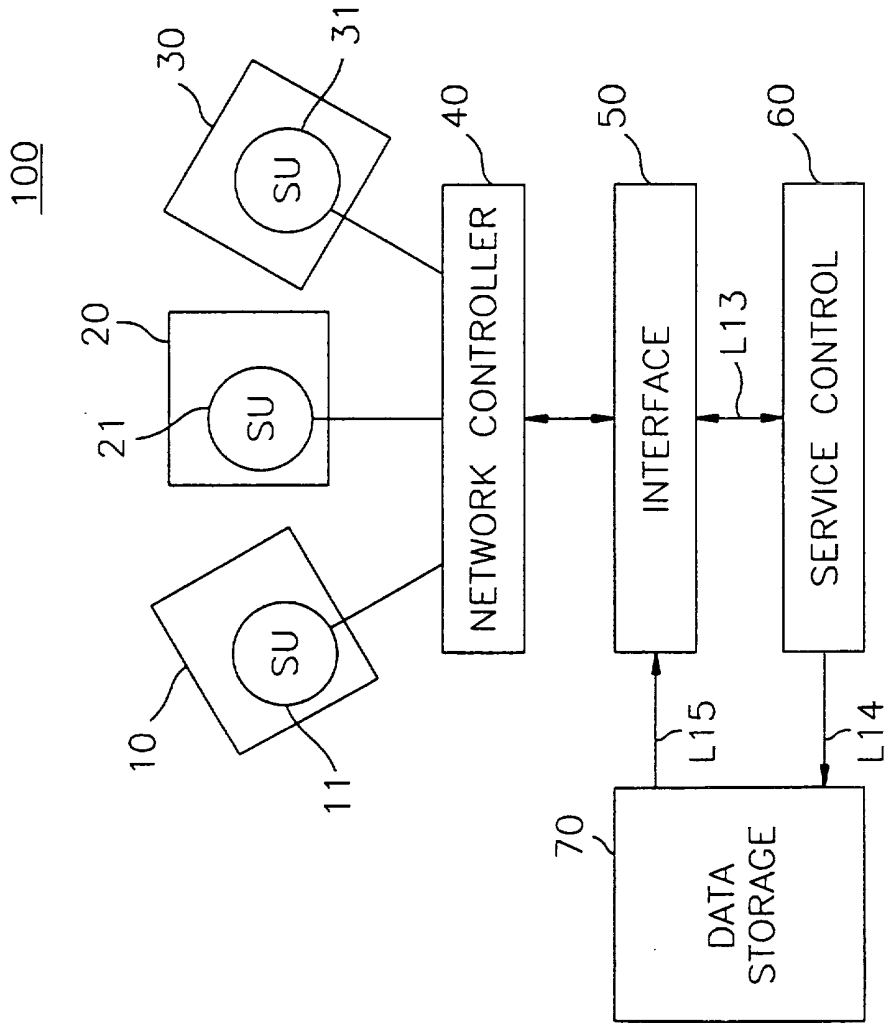

FIG. 2

60

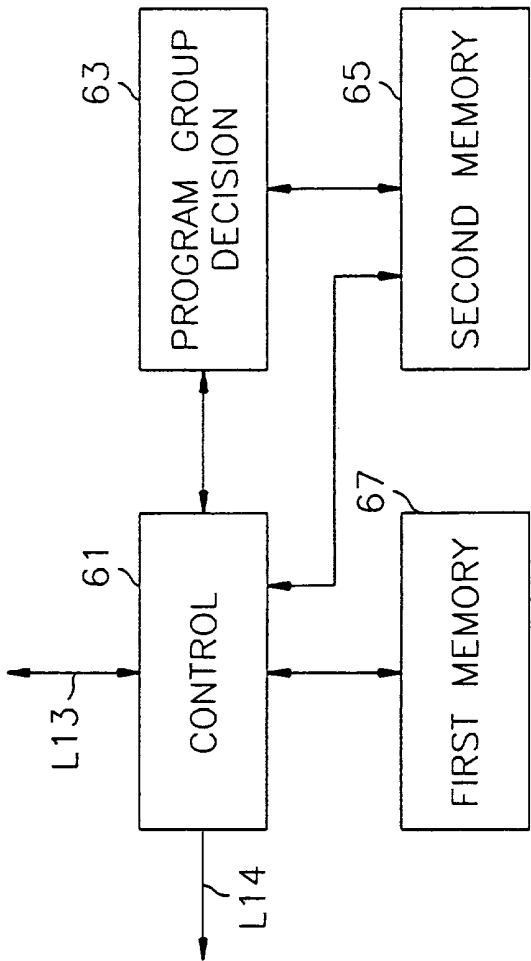

FIG. 3A

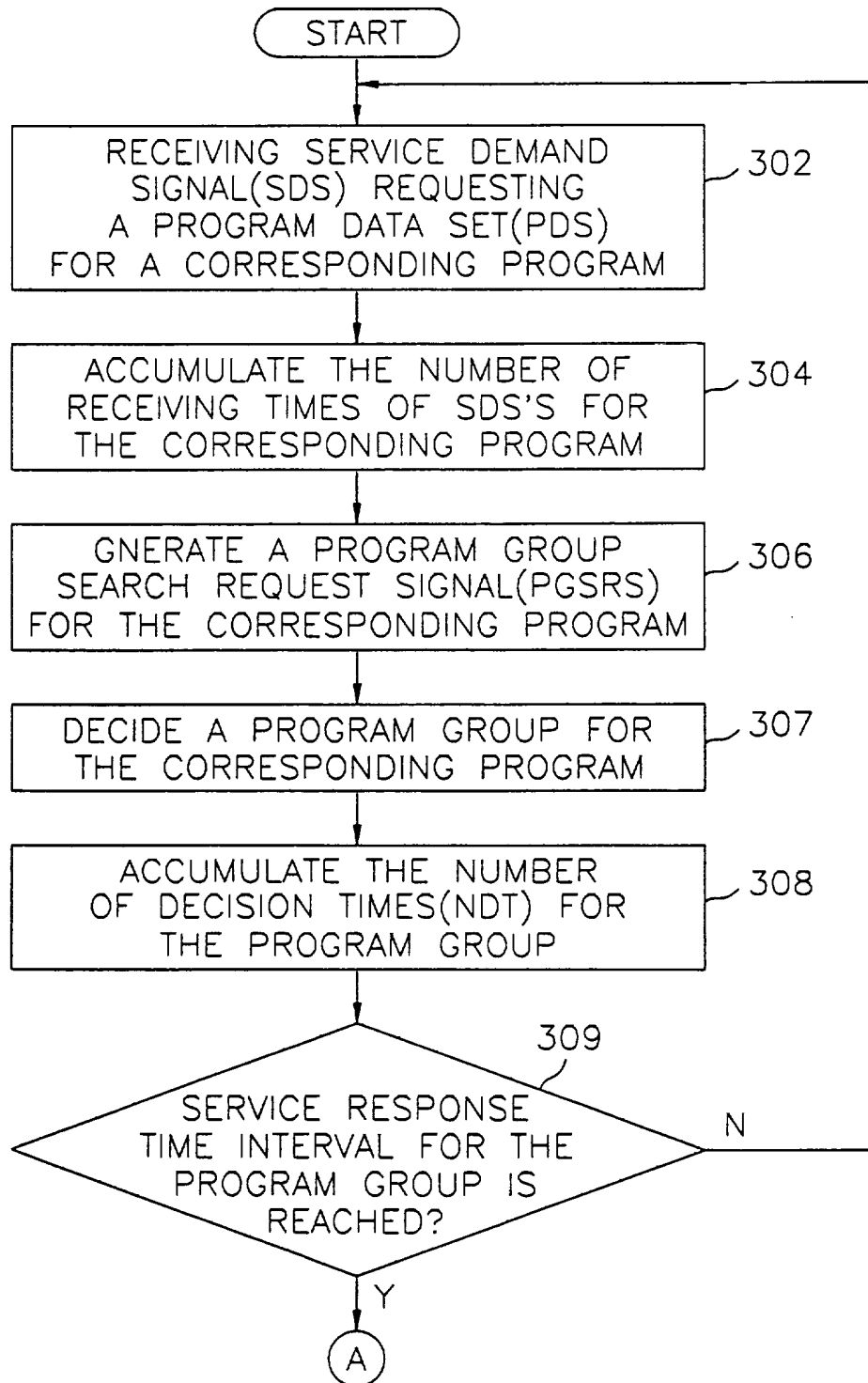

FIG. 3B

FIG. 4

330

*FIG. 5A*500

NAME OF PROGRAM GROUP	PREVIOUS RSBT	CURRENT ACCUMULATED NDT	CURRENT RSBT
PG1	T2	55	T1
PG2	T2	43	T2
PG3	T3	35	T3
PG4	T4	28	T4

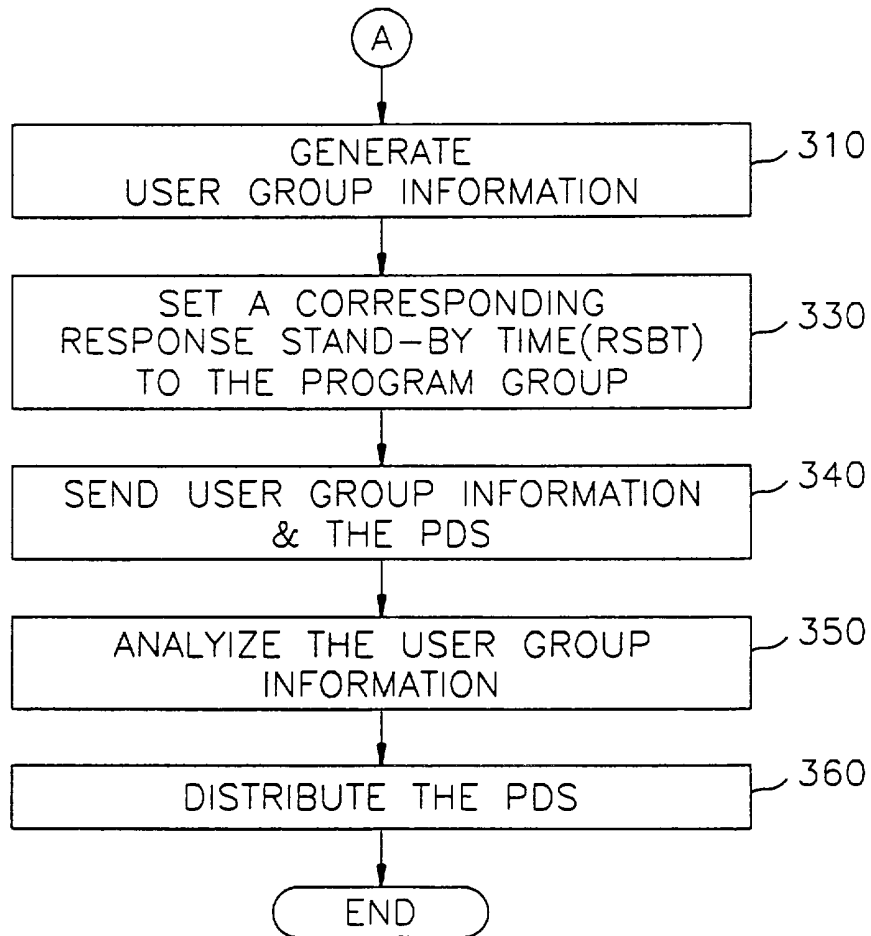
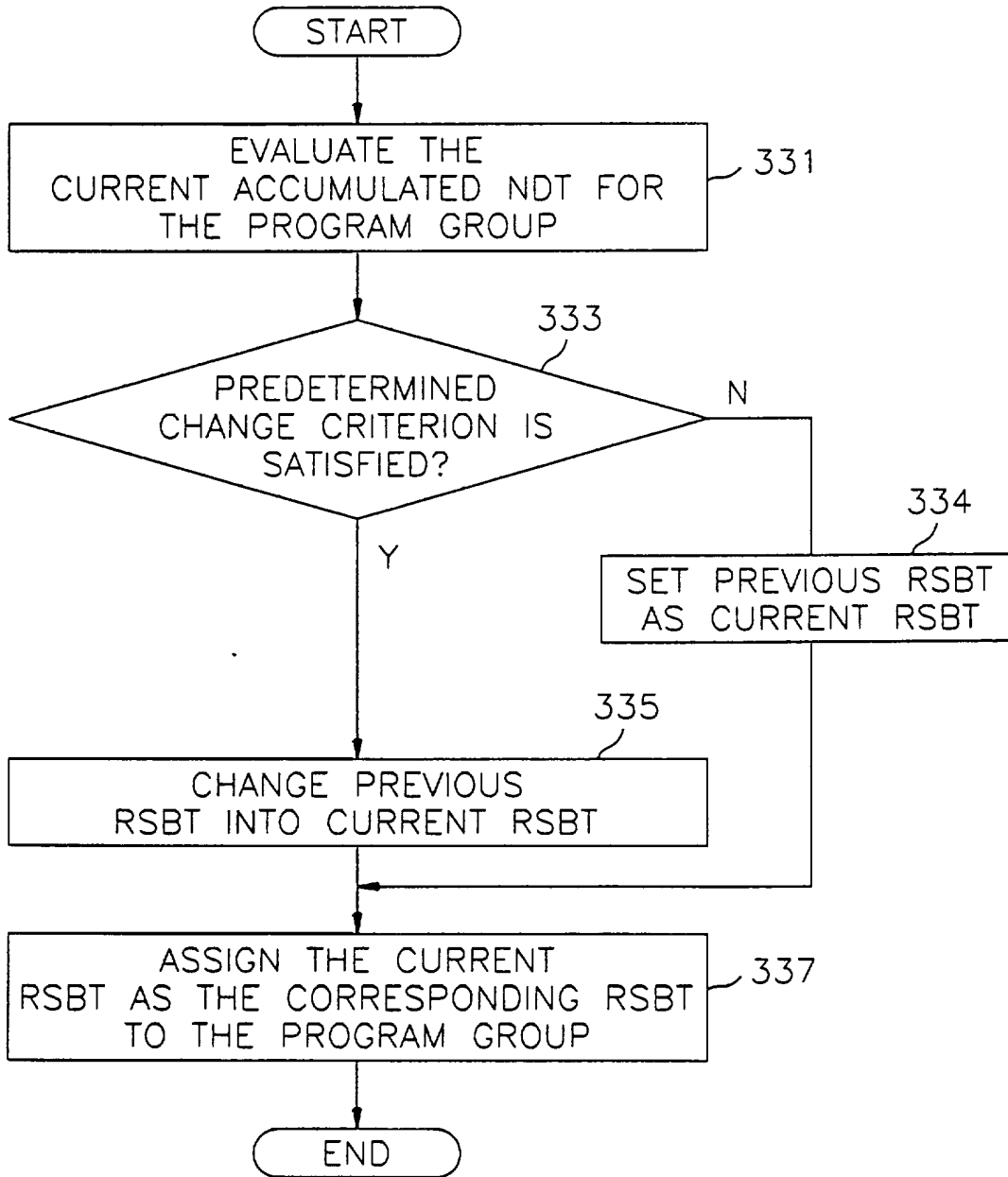
FIG. 5B

550

NAME OF PROGRAM GROUP	PREVIOUS ACCUMULATED NDT	PREVIOUS RSBT (SECONDS)	CURRENT ACCUMULATED NDT	CURRENT RSBT (SECONDS)
PG11	40	20	30	15
PG12	60	30	63	30
PG13	82	40	76	40
PG14	102	50	95	50

SERVICE CONTROL METHOD
FOR USE IN A VIDEO ON DEMAND SYSTEM

5 The present invention relates to a video on demand system; and, more particularly, to a service control method for use in a video on demand system.

10 As the so-called information superhighway is being developed, a wide communication channel which interconnects households and businesses provides many services to those who are connected thereto. These services may include banking at home, instant access to large databases and real time
15 interaction with virtual communities of people with similar interests.

 Of the services available through the superhighway, one that has received a great deal of corporate and media attention is the supply of video on demand (VOD) services.
20 Desirable VOD services can include such videos as movies, sporting events, interactive games, home shopping, textual information, educational programs and arts programs.

 A conventional VOD system is usually provided with a data storage channel for storing a plurality of program data sets
25 for corresponding programs, a network controller, a service control circuit and an interface.

In the VOD system, under the control of the service control circuit, in response to service demand signals (SDS's) from settop units (SU's) included in user devices (UD's), e.g., personal computers, program data sets for corresponding programs are retrieved; and then the retrieved program data sets are supplied to the SU's through the interface and the network controller in sequence. It is well known in the art that the larger the storage capacity of the data storage channel, the faster the data service speed in the VOD system.

Since, however, the storage capacity of the data storage channel is practically limited, an efficient service control method is essential to realize a fast data service in the VOD system.

In accordance with a conventional service control method of the VOD system, in case that SDS's requesting a certain program data set issued by a plurality of UD's are fed to the service control circuit during a fixed response stand-by time, e.g., 30 seconds, after the fixed response stand-by time being elapsed, the program data set is retrieved from the data storage channel and then the retrieved program data set is supplied to the UD's, simultaneously.

Namely, the conventional service control method assigns a fixed response stand-by time (RSBT) to every program data set regardless of the differences in the number of UD's requesting the program data sets during the fixed RSBT. Hence, for example, in the conventional service control

method, in case that the average numbers of UD's requesting program data sets (PDS's) PDS1 and PDS2 are 100 and 1000 per one day, respectively, under a fixed RSBT, e.g., 30 seconds, the data service efficiency for the PDS1 is estimated as 1/10
5 of that for the PDS2.

Therefore, the conventional service control method employing a fixed RSBT to every program data set limits the data service efficiency of the VOD system.

10

Embodiments of the present invention may

provide a service control method for use in a video on demand (VOD) system that enhances data service efficiency by assigning or setting response stand-by times adaptively on program groups having a plurality of program
15 data sets (PDS's) in accordance with the differences in the numbers of user devices (UD's) requesting the PDS's.

In accordance with the present invention, there is provided a service control method for use in a video on demand
20 (VOD) system provided with a network controller and a data storage channel for storing a plurality of program data sets (PDS's) for corresponding programs, wherein the VOD system, in response to service demand signals from user devices (UD's), retrieves PDS's for corresponding programs and then
25 provides the PDS's to the UD's through the network controller, the method comprising the steps of: (a) receiving a service

demand signal (SDS), from a UD requesting a PDS for a corresponding program; (b) accumulating the number of receiving times of SDS's for the corresponding program; (c) generating a program group search request signal (PGSRS) for the corresponding program; (d) deciding, in response to the PGSRS, a program group for the corresponding program; (e) accumulating the number of decision times (NDT) for the program group to thereby generate a current accumulated NDT; (f) repeating said steps (a) to (e) in sequence until a predetermined service response time interval for the program group is reached; (g) generating a user group information in case that the predetermined service response time interval for the program group is reached, wherein the user group information identifies a user group and UD's thereof, the user group having all of the UD's requesting the PDS for the corresponding program; (h) setting a corresponding response stand-by time (RSBT) to the program group based on the current accumulated NDT for the program group; and (i) sending the user group information and the PDS for the corresponding program.

The above and other objects and features of the present invention will become apparent from the following description of preferred embodiments given with reference to the accompanying drawings, in which:

Fig. 1 shows a schematic block diagram of a video on demand (VOD) system employing a service control method of the present invention;

Fig. 2 represents a detailed block diagram of the service control circuit illustrated in Fig. 1;

Figs. 3A and 3B set forth a flow chart for illustrating a service control method in accordance with a preferred embodiment of the present invention;

Fig. 4 illustrates a flow chart for showing a detailed process of a step included in the method represented in Fig. 3A in accordance with the preferred embodiment of the present invention; and

Figs. 5A to 5B list tables for use in describing the service control method in accordance with the preferred embodiment of the present invention.

Referring to Fig. 1, there is shown a schematic block diagram of a video on demand (VOD) system 100 employing a service control method of the present invention. The VOD system 100 comprises a data storage channel 70, a service control circuit 60, an interface 50, a network controller 40 and a plurality of user devices (UD's).

For the sake of simplicity, there are shown only three UD's 10, 20 and 30 in Fig. 1. The UD's, e.g., UD's 10, 20 and 30, include therein corresponding settop units (SU's), e.g.,

SU's 11, 21 and 31, respectively. The UD's may be personal computers, interactive televisions, video cassette recorders or the like.

In the VOD system 100, in response to service demand signals (SDS's) from the UD's thereof, program data sets for corresponding programs are retrieved from the data storage channel 70 storing a plurality of program data sets (PDS's) and then the retrieved program data sets are transmitted to the UD's, e.g., the UD's 10, 20 and 30, through the network controller 40.

Fig. 2 represents a detailed block diagram of the service control circuit 60 shown in Fig. 1. The service control circuit 60 includes a control circuit 61, a first memory 67, a program group decision group 63 and a second memory 65.

Figs. 3A and 3B set forth a flow chart for illustrating a service control method in accordance with a preferred embodiment of the present invention. Fig. 4 illustrates a flow chart for showing a detailed process of a step 330 included in the method represented in Fig. 3A. Figs. 5A and 5B list tables 500 and 550, respectively, for use in describing the service control method in accordance with the preferred embodiment of the present invention.

From now on, the service control method in accordance with the preferred embodiment of the present invention will be described in detail with reference to Figs. 1-2, 3A-3B, 4 and 5A-5B.

First, a service control process or method in accordance with a preferred embodiment of the present invention is initiated in case that a SDS is inputted to the service control circuit 60 via a line L13 through the network controller 40 and the interface 50 in sequence.

At step 302, a SDS from a UD, e.g., the UD 10, generated by a SU, e.g., the SU 11 in the UD 10, requesting a PDS for a corresponding program is received, e.g., by the control circuit 61 in the service control circuit 60. Then, the process goes to step 304.

At step 304, the number of receiving times of SDS's for the corresponding program is accumulated by 1, e.g., at the first memory 67 under the control of the control circuit 61. Thereafter, the process flows to step 306.

At step 306, a program group search request signal, denoted as PGSRS, for the corresponding program is generated, e.g., by the control circuit 61 and then the PGSRS is fed to the program group decision circuit 63. The process proceeds to step 307.

At step 307, in response to the PGSRS, a program group for the corresponding program is decided, e.g., by the program group decision circuit 63. For example, the program group decision circuit 63 decides the program group for the corresponding program by searching program group information previously stored in the second memory 65. The process flows to step 308.

At step 308, the number of decision times (NDT) for the program group is accumulated by 1, e.g., at the second memory 65, e.g., under the control of the control circuit 61 to thereby generate a current accumulated NDT.

5 Next, at steps 309-310, based on the program group and the current accumulated NDT, a user group information is generated in case that a predetermined service time interval for the program group is reached, wherein the user group information identifies all of the UD's requesting the PDS for
10 the corresponding program.

 In detail, at step 309, in case that a predetermined service response time interval for the program group is reached, the process goes to step 310 through a tap A as shown in Figs. 3A and 3B. But, if the predetermined service
15 response time interval is not reached, the process returns to step 302. Namely, steps 302 to 308 are repeated in sequence until the predetermined service response time interval for the program group is reached.

 At step 310, the user group information is generated,
20 e.g., by the program group decision circuit 63, wherein the user group information identifies a user group and UD's thereof, the user group having all of the UD's requesting the PDS for the corresponding program. Then, the process proceeds to step 330.

25 At step 330, a corresponding response stand-by time, denoted as RSBT, is set to the program group, e.g., by the

program group decision circuit 63 based on the current accumulated NDT for the program group. In accordance with a preferred embodiment of the present invention, step 330 includes steps 331, 333, 334, 335 and 337 as shown in Fig. 4.

5 In detail, at step 331, the current accumulated NDT for current program groups are evaluated. Thereafter, at step 333, it is checked based on the current accumulated NDT whether or not a predetermined change criterion is satisfied. If the predetermined change criterion is satisfied, the process flows to step 335; and if the predetermined change
10 criterion is not satisfied, the process goes to step 334.

 At step 334, a previous RSBT for the program group is set as a current RSBT therefor; and in turn the process goes to step 337. At step 335, based on the current accumulated NDT,
15 the previous RSBT for the program group is changed into a current RSBT therefor, wherein the current RSBT is different from the previous RSBT.

 It should be noted that the previous RSBT and the previous accumulated NDT for the program group used at steps
20 334 and 335 are previously obtained, e.g., by the control circuit 61. For example, at the first turn-on time of the VOD system on a certain day, the previous RSTB and the previous accumulated NDT are obtained by averaging RSTB's and previous accumulated NDT's over past 7 days before the certain day,
25 respectively.

 Further, in accordance with a preferred embodiment of the

present invention, after performing the steps 334 and 335, the current RSBT and the current accumulated NDT are set as a previous RSBT and a accumulated previous NDT, respectively, for use in a subsequent process including repeated steps 302 to 330.

Thereafter, at step 337, a current RSBT among the current RSBT's are assigned to the program group to thereby set the corresponding RSBT to the program group. Then the step 330 is ended. From now on, referring to Figs. 5A and 5B, the step 333 is described in more details.

In accordance with a preferred embodiment of the present invention, at step 333, the predetermined change criterion requires that a current accumulated NDT for the program group during the previous RSBT deviates from a corresponding predetermined NDT range.

Fig. 5A lists a table 500 for use in describing the service control method in accordance with the preferred embodiment of the present invention. In Fig. 5A, for example, it is assumed that corresponding predetermined NDT ranges are set to be 50-59, 40-49, 30-39, 20-29 during previous RSBT's T1, T2, T3 and T4, respectively, wherein $T1 < T2 < T3 < T4$.

In this case, the current accumulated NDT, e.g., 55, for a program group PG1 during the previous RSBT T2 deviates from the corresponding predetermined NDT range, i.e., 40-49. Hence, since the predetermined change criterion is satisfied, the previous RSBT, i.e., T2, for the program group PG1 is

changed into a current RSBT, i.e., T1, therefor as listed in Fig. 5A.

But, since the predetermined change criterion is not satisfied for program groups PG2, PG3 and PG4, the previous RSBT's, i.e., T2, T3 and T4, are set as current RSBT's T2, T3 and T4, for the program groups PG2, PG3 and PG4, respectively.

In accordance with another preferred embodiment of the present invention, at step 333, the predetermined change criterion requires that CRV is either less than α PRV or greater than β PRV, wherein CRV is a current reference value obtained through dividing the current accumulated NDT for the program group by a previous RSBT; PRV is a previous reference value obtained through multiplying the previous accumulated NDT for the program group by the previous RSBT; α is a preset positive constant less than 1; and β is a preset constant greater than 1.

Fig. 5B lists a table 550 for use in describing the service control method in accordance with the another preferred embodiment of the present invention. In Fig. 5B, for example, it is assumed that previous RSBT's for program groups PG11, PG12, PG13 and PG 14 are 20, 30, 40 and 50 in seconds, respectively.

In this case, if α is 0.8 and β is 1.2, CRV becomes 1.5 (=30/20) for the program group PG11. Hence, since CRV for the program group PG11, i.e., 1.5, is less than α PRV, i.e., 1.6 (=0.8x(40/20)), the previous RSBT, i.e., 20, for the program

group PG11 is changed into a current RSBT, e.g., 15, therefor.

But, for example, since CRV for the program group PG12, i.e., 2.1 $(=(63/30))$ falls between α PRV, i.e., 1.68 $(0.8 \times (63/30))$, and β PRV, i.e., 2.52 $(=1.2 \times (63/30))$, the previous
5 RSBT, i.e., 30, for the program group PG12 is set as a current RSBT, i.e., 30, therefor.

In accordance with a preferred embodiment of the present invention, at step 335, a previous RSTB is changed into an optimum current RSBT as the current RSTB among predetermined
10 RSTB's, wherein the optimum current RSTB is a predetermined RSTB which yields a nearest value to the PRV. It should be also noted that for simplicity, at step 335, each of previous and current RSBT's are set in 5 or 10 seconds.

Thereafter, at step 340, the user group information and
15 the PDS for the corresponding program are sent, e.g., by the control circuit 61. For example, the control circuit 61 sends the user group information to the network controller 40 through the interface 50 via the line L13. At the same time, the control circuit 61 issues a PSD supply command signal to
20 the data storage channel 70 via a line L14.

Then, the data storage channel 70, in response to the PSD supply command signal, retrieves a PSD for the corresponding program to thereby supply the PSD to the network controller 40 through the interface 50 via a line L15. Then, the process
25 goes to step 350.

At step 350, the user group information is analyzed to

thereby generate an analyzed information. Then the process flows to step 360. At step 360, based on the analyzed information, the PDS is distributed to corresponding UD's.

For example, the network controller 40 analyzes the user
5 group information to thereby generate the analyzed information, e.g., having addresses for corresponding UD's requesting the PDS for the corresponding program and then distributes the PDS to the corresponding UD's based on the addresses for the corresponding UD's. Then the process is
10 ended.

While the present invention has been described with respect to certain preferred embodiments only, other modifications and variations may be made without departing from the scope of the present invention as set forth in the
15 following claims.

Claims

1. A service control method for use in a video on demand (VOD) system provided with a network controller and a data storage channel for storing a plurality of program data sets (PDS's) for corresponding programs, wherein the VOD system, in response to service demand signals from user devices (UD's), retrieves PDS's for corresponding programs and then provides the PDS's to the UD's through the network controller, the method comprising the steps of:

- (a) receiving a service demand signal (SDS), from a UD requesting a PDS for a corresponding program;
- (b) accumulating the number of receiving times of SDS's for the corresponding program;
- (c) generating a program group search request signal (PGSRS) for the corresponding program;
- (d) deciding, in response to the PGSRS, a program group for the corresponding program; and
- (e) accumulating the number of decision times (NDT) for the program group to thereby generate a current accumulated NDT.

2. The method according to claim 1, further comprising the steps of:

- (f) repeating said steps (a) to (e) in sequence until a predetermined service response time interval for the program

group is reached;

(g) generating a user group information in case that the predetermined service response time interval for the program group is reached, wherein the user group information identifies a user group and UD's thereof, the user group having all of the UD's requesting the PDS for the corresponding program;

(h) setting a corresponding response stand-by time (RSBT) to the program group based on the current accumulated NDT for the program group; and

(i) sending the user group information and the PDS for the corresponding program.

3. The method according to claim 2, wherein said step (h) includes the steps of:

(h1) evaluating the current accumulated NDT for the program group;

(h2) changing, based on the current accumulated NDT, a previous RSBT for the program group into a current RSBT therefor in case that a predetermined change criterion is satisfied;

(h3) setting the previous RSBT for the program group as a current RSBT therefor in case that the predetermined change criterion is not satisfied; and

(h4) assigning the current RSBT to the program group to thereby set the RSBT to the program group.

4. The method according to claim 3, wherein the current RSBT is different from the previous RSBT.

5. The method according to any of claims 2 to 4, further comprising
5 the steps of:

(j) analyzing the user group information to thereby generate an analyzed information; and

(k) distributing the PSD to corresponding UD's through the network controller based on the analyzed information.

10

6. The method according to any of claims 2 to 5, wherein in said step (d), the program group for the corresponding program is decided by searching program group information previously stored.

15 7. The method according to any of claims 2 to 5, wherein said step (i) includes the steps of:

(i1) issuing a PSD supply command signal; and

(i2) retrieving, in response to the PSD supply command signal, the PSD for the corresponding program from the data
20 storage channel to thereby supply the PSD to the network controller.

8. The method according to claim 3 or 4, wherein the predetermined change criterion requires that the current accumulated NDT for
25 the program group during the previous RSBT deviates from a corresponding predetermined NDT range.

9. The method according to claim 3 or 4, wherein the predetermined change criterion is to require that CRV is either less than α PRV or greater than β PRV, wherein CRV is a current reference value obtained through dividing the current accumulated NDT for the program group by a previous RSBT; PRV is a previous reference value obtained through dividing a previous accumulated NDT by the program group with the previous RSBT; α is a preset positive constant less than 1; and β is a preset constant greater than 1.

10

10. The method according to any of claims 3 to 9, wherein the analyzed information has addresses for the corresponding UD's.

11. The method according to claim 5, further comprising the step of:

(1) setting the current RSBT and the current accumulated NDT as a previous RSBT and a accumulated previous NDT, respectively.

12. The method according to any of claims 3,4 or 9, wherein in said step (h2), the previous current RSTB is changed into an optimum current RSBT as the current RSTB among predetermined RSTB's, the optimum current RSTB being a predetermined RSTB which yields a nearest value to the PRV.

25

13. The method according to claim 9, wherein α and β are 0.8 and 1.2, respectively.

14. A service control apparatus constructed and arranged
5 substantially as herein described with reference to or as shown in Figs. 1 and 2 of the accompanying drawings.

15. A service control method constructed and arranged
substantially as herein described with reference to or as
10 shown in Figs. 3A-3B, 4 and 5A-5B of the accompanying drawings.



Application No: GB 9827389.9
Claims searched: 1 to 13

Examiner: M J Billing
Date of search: 12 May 1999

Patents Act 1977
Search Report under Section 17

Databases searched:

UK Patent Office collections, including GB, EP, WO & US patent specifications, in:
UK Cl (Ed.Q): H4R RCS, RCSS, RCT, RCX.
Int Cl (Ed.6): H04N 7/173.
Other: ONLINE - EPODOC, WPI.

Documents considered to be relevant:

Category	Identity of document and relevant passage	Relevant to claims
A	GB2317082A (IBM) - Figs.7,8b,15a	1
A	EP0726535A1 (NEC) - Fig.14	1
A	EP0653886A1 (BELL) - Abstract	1
A	US5561456 (IBM) - Fig.4; Abstract	1

X	Document indicating lack of novelty or inventive step	A	Document indicating technological background and/or state of the art.
Y	Document indicating lack of inventive step if combined with one or more other documents of same category.	P	Document published on or after the declared priority date but before the filing date of this invention.
&	Member of the same patent family	E	Patent document published on or after, but with priority date earlier than, the filing date of this application.