



(51) International Patent Classification:

A61F 2/00 (2006.01) A61B 17/00 (2006.01)
A61F 2/24 (2006.01) A61B 17/064 (2006.01)

(21) International Application Number:

PCT/IL2018/050351

(22) International Filing Date:

27 March 2018 (27.03.2018)

(25) Filing Language:

English

(26) Publication Language:

English

(30) Priority Data:

62/476,908 27 March 2017 (27.03.2017) US
62/608,629 21 December 2017 (21.12.2017) US

(71) Applicant: **VVITAL BIOMED LTD.** [IL/IL]; 42 Etzion Street, 4356321 Raanana (IL).

(72) Inventor: **SMOLINSKY, Aram Kurt**; 12 Hamarganiut Street, 4265212 Netanya (IL).

(74) Agent: **FISHER, Michal** et al.; FISHER IP GROUP, PO BOX 12352, 4673300 Hertzliya Pituach (IL).

(81) Designated States (unless otherwise indicated, for every kind of national protection available): AE, AG, AL, AM, AO, AT, AU, AZ, BA, BB, BG, BH, BN, BR, BW, BY, BZ, CA, CH, CL, CN, CO, CR, CU, CZ, DE, DJ, DK, DM, DO,

DZ, EC, EE, EG, ES, FI, GB, GD, GE, GH, GM, GT, HN, HR, HU, ID, IL, IN, IR, IS, JO, JP, KE, KG, KH, KN, KP, KR, KW, KZ, LA, LC, LK, LR, LS, LU, LY, MA, MD, ME, MG, MK, MN, MW, MX, MY, MZ, NA, NG, NI, NO, NZ, OM, PA, PE, PG, PH, PL, PT, QA, RO, RS, RU, RW, SA, SC, SD, SE, SG, SK, SL, SM, ST, SV, SY, TH, TJ, TM, TN, TR, TT, TZ, UA, UG, US, UZ, VC, VN, ZA, ZM, ZW.

(84) Designated States (unless otherwise indicated, for every kind of regional protection available): ARIPO (BW, GH, GM, KE, LR, LS, MW, MZ, NA, RW, SD, SL, ST, SZ, TZ, UG, ZM, ZW), Eurasian (AM, AZ, BY, KG, KZ, RU, TJ, TM), European (AL, AT, BE, BG, CH, CY, CZ, DE, DK, EE, ES, FI, FR, GB, GR, HR, HU, IE, IS, IT, LT, LU, LV, MC, MK, MT, NL, NO, PL, PT, RO, RS, SE, SI, SK, SM, TR), OAPI (BF, BJ, CF, CG, CI, CM, GA, GN, GQ, GW, KM, ML, MR, NE, SN, TD, TG).

Declarations under Rule 4.17:

— of inventorship (Rule 4.17(iv))

Published:

— with international search report (Art. 21(3))

(54) Title: DEVICE AND METHOD FOR TRANSCATHETER MITRAL AND TRICUSPID VALVE REPAIR

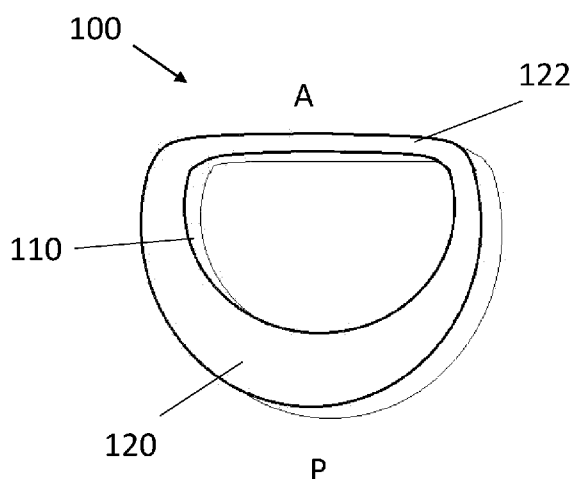

FIG. 1A

(57) Abstract: There is provided herein a supra mitral device for mitral/tricuspid valve repair in a subject in need thereof, the device comprising: a main body portion having essentially annular D-shape with an eccentric opening, such that a posterior section of said main body portion is wider than an anterior section of said main body portion, said posterior section of said main body portion configured for coverage and attachment to essentially the whole section of the posterior leaflet of the mitral valve which faces the left atrium on systole, thereby preventing and/or reducing mitral regurgitation, wherein said posterior section of said main body portion is made of a pliable material, adapted to stiffen after implantation of the device.



DEVICE AND METHOD FOR TRANSCATHETER MITRAL AND TRICUSPID VALVE REPAIR

TECHNICAL FIELD

The present disclosure generally relates to devices and methods for
5 Transcatheter Atrioventricular Valves Repair or Replacement, namely the mitral and
the tricuspid valves, Commonly termed Trans Catheter Mitral Valve Replacement
(TMVR) or repair (TMVRr), or Per Cutaneous Mitral Valve Repair or Replacement
(PCMVR).

BACKGROUND

10 The atrioventricular valves are one-way valves, and like their name implies, are
the passage from the atria to the ventricles. On the left side of the heart, situated between
the left atrium and the left ventricle is the Mitral Valve. On the right side of the heart,
situated between the right atrium and right ventricle is the Tricuspid Valve. Their basic
anatomy is quite similar. The mitral apparatus has three components: 1) The leaflets,
15 which function like doors of a one-way gate that actually hold the blood from flowing
back from the left ventricle to the left atrium. 2) The chordae (chords) that hold the free
margin of the leaflets on one end and the heart myocardium (muscle) on the other end.
3) The papillary muscles (they are an intrinsic part of the heart muscle) which anchor
the chordae to the heart muscle/ myocardium. As a complete system, it resembles two
20 half-domes of a parachute, with chords at its free margins, anchored on the papillary
muscles tips (like the paratrooper in this comparison). Damage/disease of any one of
the mitral valve apparatus components can prevent proper leaflet coaptation, namely
mitral regurgitation (MR), also termed mitral insufficiency (MI) or mitral leak.

There are usually two major leaflets (the anterior leaflet and the posterior
25 leaflet), that guard the opening, surrounded by the so called mitral valve annulus ("so
called" because the term annulus implies a complete ring, which it is not, there is no
annulus tissue at the middle of the posterior leaflet). Thus, during left ventricular
systole, when the left ventricle contracts, the ensuing rise in intra-ventricular pressure
fills the valve and pushes it backward (backward relates to the expected blood flow
30 direction, also referred to as retrograde) toward the left atrium. The chordae tendineae
stop the leaflets at the plane of the annulus, where the valve closes the passage from the

ventricle to the left atrium, and the leaflets free margins coapt. Coaptation means that unlike a gate door, the leaflet half-domes are like a parachute- most of it facing the left atrium, the margins however dome down into the ventricle and coapt with the down doming part of the opposing leaflet. A one-way valve mechanism is thus established.

5 During diastole, the pressure in the left ventricle drops abruptly to around zero mmHg and the pressure gradient between the atria and the ventricle reverses. Now the atrial pressure is higher than the ventricular pressure, and blood flows down the pressure gradient from the left atrium to the left ventricle, pushing the mitral leaflets toward the ventricle, thus opening the valve which facilitates blood flow into the left ventricle.

10 Mitral regurgitation (MR), also referred to as mitral insufficiency, mitral incompetence or mitral valve leak, is a disorder of the heart in which the mitral valve does not close properly during LV contraction, and ensuing rise in the LV pressure. Valve regurgitation means some blood flows backwards from the left ventricle, through the malfunctioning segment of the mitral valve, into the left atrium. The resultant rise
15 in left atrial pressure causes blood congestion in the lung, whose clinical manifestation is shortness of breath on effort, up to pulmonary edema and death, a situation called congestive heart failure of varying degrees.

The etiologies of MR can be presented as two groups:

- Primary MR (also: Structural MR, Degenerative MR)
- 20 • Secondary MR (Functional MR, FMR)

Primary and secondary MR are fundamentally different diseases, which share improper leaflet coaptation, which can, however, in some situations be treated with the same technological approach. They differ in their pathophysiology, anatomy, outcomes and approaches to treatments. Whereas in degenerative MR there is an obvious
25 structural defect, like torn chordae, severe myxomatous changes, fibro-elastic deficiency or post SBE damage; in functional MR the valve appears normal. However, MR does occur due to a dysfunction related to other components of the mitral valve apparatus: the heart muscle (myocardium). The impairment is due to an infarcted posterior wall which causes inappropriate posterior leaflet movement and, as a result,
30 as the heart muscle is attached to the valve via the chordae, the posterior leaflet is pulled

down ("Tethering of the posterior leaflet"), proper coaptation of the anterior and posterior leaflets is not achieved.

Whatever the causal factor is, degenerative or functional, proper coaptation of the leaflets is not achieved. Every valve repair device has to re-institute a good
5 coaptation, in order to reduce/abolish the mitral leak. Also, whatever the casual factor is, the volume of the regurgitant valve becomes an addition to the basic normal full diastolic volume of the LV, which means extra volume load on the heart on each heart bit/cycle. The heart adapts to the increase in volume by slow dilatation of all chambers, both left atrium (LA) and LV, including mitral annulus dilatation as well, which
10 generates even more MR and even more volume load on the left heart. A vicious cycle is thus established, in which occurrence of MR causes a gradual increase of the MR severity. Whatever the etiology, the valve repair device has to include prevention of further annular dilatation, or even reduction of the annular diameter. Degenerative mitral valve disease accounts nowadays for approximately 85% of the patients;
15 however, its incidence is not expected to rise. However, functional MR is the rapidly growing segment of the mitral regurgitation population, mostly reflecting the rise in the age of the population (as much as 13% of people above 75 years have some FMR).

Procedures for mitral valve replacement and repair, which have proven to be efficient and reproducible, are employing open heart surgery. They are extremely
20 invasive, require considerable recovery time, and in very high-risk patients may have prohibitive mortality. Per-cutaneous techniques now enable surgeons/invasive cardiologists to access cardiac valves without open-heart surgery. Catheters are inserted into vasculature at a site that is relatively distant from the heart, or directly via the heart apex. The catheters carry therapeutic devices through the patient's vasculature (or trans-
25 apical) to the malfunctioning heart valve. Such per-catheter minimally invasive devices and procedures are well developed and approved for stenotic aortic valves. This technique was found not to be applicable to the regurgitant mitral valve due to the distinct differences between the calcific and stenotic aortic valves and the regurgitant mitral valves pathologic anatomy.

30 The many attempted projects of TMVR (Transcatheter Mitral Valve Replacement) until now have not had much success. None have received FDA approval and are far from competing with or even approaching the surgical results. In TMVRr

(Transcatheter Mitral Valve Repair) one device, the MitraClip (by Abbott), is FDA approved recently and is employed. It is a transcatheter version of the surgical “Alfieri Repair” (edge to edge technique). However, the edge to edge repair was proven to be not as effective without additional annuloplasty. This may explain the limited and highly selective group of patients MitraClip is good for.

There thus remains a real unmet need for percutaneous trans-catheter techniques for repairing and/or replacing mitral valves and tricuspid valves for a large patient population which was not met until now.

SUMMARY

The following embodiments and aspects thereof are described and illustrated in conjunction with systems, tools and methods, which are meant to be exemplary and illustrative, not limiting in scope. In various embodiments, one or more of the above-described problems have been reduced or eliminated, while other embodiments are directed to other advantages or improvements.

According to some embodiments, there is provided a supra mitral device for mitral/tricuspid valve repair, the supra mitral device having an essentially annular shape - D shape and having an opening (e.g., an eccentric opening), such that the width of the posterior section of the supra mitral device is essentially the same as the amplitude/height of the section of the posterior mitral leaflet which faces the left atrium on systole, while the width of the anterior section of the supra mitral device is thinner than the width of the posterior section (and may typically be 3-8 mm).

According to some embodiments, the supra mitral device may be used to treat primary mitral regurgitation (MR) (also called: structural MR, degenerative MR).

According to additional or alternative embodiments, the supra mitral device may be used to treat secondary MR (also called: functional MR, or FMR).

According to some embodiments, the supra mitral device may be used for mitral valve repair and/or for tricuspid valve repair.

According to some embodiments, there is provided a supra mitral device having a “horse shoe” configuration or a D shape where the anterior section is partial or

incomplete, such that the supra mitral device has a form of an unclosed ring (opened perimeter where the two ends of the supra mitral device are not joined), or any other shape which is configured for attachment to the posterior leaflet of the mitral valve. According to some embodiments, the two ends of the unclosed ring may be configured
5 to overlap once positioned on the valve leaflets and optionally, to be coupled to the leaflet, thus securing the overlap of the two ends. The overlap may be anteriorly or posteriorly (namely, two layers over the middle of the posterior leaflet, the P2 segment).

According to some embodiments, the supra mitral device is configured for attachment to the leaflets of the mitral valve all around, thereby preventing and/or
10 alleviating mitral regurgitation and/or prolapse of segments of the posterior leaflet.

According to some embodiments, attachment of the supra mitral device to the functioning leaflet of the mitral valve is a means to engage the many chordae that were not torn, via the attachment to the valve leaflet, to support the flailing segment. According to some embodiments, supra mitral device attachment to the mitral valve
15 annulus is avoided, in order to let the chordae take the load without involving any rigid or nearly rigid reference like the annulus. Supra mitral device attachment to the mitral valve annulus may constrain the natural and effective load distribution on the multitude of untorn chordae.

As a further advantage, the supra mitral device stays attached /adherent to the
20 posterior leaflet throughout the cardiac cycle; thus they move together. Consequently, there is no recurring encounter between the supra mitral device and the posterior leaflet in each heartbeat. This is as opposed to fixed plate-like devices, configured for attachment to the mitral valve annulus, where the posterior leaflets strike the plate in each systole, thus causing accumulated damage to the leaflet tissue.

25 According to some embodiments, the supra mitral device is made of a pliable material, adapted to stiffen slowly after implantation of the device. This advantageously enables the supra mitral device to adopt the anatomical shape of the leaflet tissue, maintaining the functioning chordae in their natural length, thereby preserving the even load distribution among them, while absorbing the systolic thrust of the LV pressure.

30 According to some embodiments, there is further provided an attachment/coupling element made of a memory shape material (e.g., smart metal alloy)

or coiling tendency, configured to assume the function of a rivet and connect the supra mitral device to the desired part(s) of the mitral leaflets.

According to some embodiments, the attachment/coupling element(s) may have a size in the range of 3-15mm, such as 5-7mm or 4-10mm.

5 According to some embodiments, the attachment/coupling element(s) may have a first spiral (the term "spiral" may also be referred to as a "coil") and a second spiral interconnected by an essentially straight wire. Each spiral may have a conus shape, the two conus shapes are facing each other at their bases, connected by the same wire that constitutes them, from the tip of the first conus to the tip of the second conus. According
10 to some embodiments, the distal end of the first end forms the outermost loop of the first spiral, whereas the proximal end of the first end forms the innermost loop of the first spiral. Similarly, the distal end of the second end forms the innermost loop of the second spiral; whereas the proximal end of the second end forms the outermost loop of the second spiral. This configuration apposes the two wide bases of the conus shapes at
15 each side of the two sheets it is meant to keep together; the mitral leaflet and supra mitral device material are held in position by the central wire tip to tip, and the elastic spring-like action of the spirals. This wide and elastic grip is meant to prevent tearing of the tissue to which it is attached when a pull force is applied at either end of the coupling element. For example, according to some embodiments, the coupling element
20 is configured for attaching a supra mitral device to the mitral leaflets all around, in which case the spirals of the attachment/coupling element (rivets) are positioned on opposite sides of the supra mitral device and of the posterior leaflet, thereby causing attachment of the supra mitral device to the leaflet tissue. According to some embodiments, the basic wire structure may be with featherlike enveloping fibers. This
25 is meant to cushion its touch on the tissue, as well as to form a skeleton for clots and tissue formation. The term "wire" does not imply it is necessarily metallic. It may be metallic, but may be of other materials, such as polymers, natural materials and other materials having inherent coiling characteristics (see for example, as exists in the plant *Erodium Cicutarium* ("stork's-bill")).

30 According to some embodiments, a second coupling element may be constructed by a couple of spirals connected to each other, for example, at their outer curve. This way it is only the wider outer curve of the spiral which is in touch with the

leaflet and supra mitral device. The spirals' plane may be right angled to the supra mitral device/leaflet plane, and parallel to the chordae. The same principle may be expanded to two, three, or more couples of spirals in one coupling element.

According to some embodiments, a later second stage option exists, if residual
5 mitral regurgitation is deemed unacceptable on follow-up, to employ the supra mitral device as a docking system for per-catheter mitral valve replacement.

According to some embodiments, there is provided herein a device for mitral valve repair in a subject in need thereof, the device comprising: a supra mitral device having essentially annular D-shape with an eccentric opening, such that a posterior
10 section of the supra mitral device is wider than an anterior section of the supra mitral device, the posterior section of the supra mitral device configured for coverage and attachment to essentially the whole section of the posterior leaflet of the mitral valve which is facing the left atrium, thereby preventing and/or minimizing mitral regurgitation, wherein the posterior section of the supra mitral device is made of a
15 pliable material, adapted to stiffen slowly after implantation of the device. According to some embodiments, the device is configured for trans-catheter implantation.

According to some embodiments, the posterior section of the supra mitral device is configured to stay attached/adherent to the part of the posterior leaflet, which is facing the left atrium, throughout the cardiac cycle, immobilizing the posterior leaflet
20 to an essentially permanently elevated/closed position. The posterior section of the supra mitral device is attached to the posterior leaflet while assuming a shape of the posterior leaflet. Such shape may be wavy or curvy.

According to some embodiments, the supra mitral device is not directly attached to an annulus of the mitral valve. The supra mitral device may further comprise a
25 plurality of through holes for securing the device to the mitral valve leaflet.

According to some embodiments, the device may further include a plurality of coupling elements configured to attach the supra mitral device to the leaflet of the mitral valve. According to some embodiments, the plurality of coupling elements comprise a memory shape material (e.g., smart metal alloy) configured to assume a shape of a
30 coiled (spiral) coupling element. The coiled coupling element may include a first spiral and a second spiral interconnected by an essentially straight wire.

According to some embodiments, the coupling element is configured to be horizontal relative to the valve plane and is formed of a wire having a first end and a second end; the first end forming the first spiral and the second end forming the second spiral; wherein a distal end of the first end forms the outermost loop of the first spiral, and a proximal end of the first end forms the innermost loop of the first spiral; and wherein a distal end of the second end forms the innermost loop of the second spiral and a proximal end of the second end forms the outermost loop of the second spiral.

According to some embodiments, the coupling element is configured to be vertical relative to the valve plane and is formed of a wire having a first end and a second end; the first end forming the first spiral and the second end forming the second spiral; wherein a distal end of the first end forms the innermost loop of the first spiral, and a proximal end of the first end forms the outermost loop of the first spiral; and wherein a distal end of the second end forms the outermost loop of the second spiral and a proximal end of the second end forms the innermost loop of the second spiral.

According to some embodiments, the first and second spirals are positioned on opposite sides of the supra mitral device and mitral leaflet, when attached.

According to some embodiments, the pliable material comprises a woven material (such as woven fabric) made by any type of weaving or knitting. Yarns applied for such material may include cotton, viscose, rayon, wool, polyester, acrylic, acrylonitrile, silk or any other natural or synthetic material. According to some embodiments, the pliable material comprises a non-woven material (such as non-woven fabric). According to some embodiments, the pliable material comprises felt. The pliable material may include Teflon, Dacron (Teflon and Dacron are trademarks), PTFE (Gortex, trademark), or any combination thereof. The face of the pliable material in contact with the mitral leaflet may be pre-treated to facilitate tissue ingrowths from the mitral tissue.

According to some embodiments, the device is used for treating a subject suffering from mitral insufficiency. The mitral insufficiency may include fibroelastic deficiency, myxomatous mitral valve, functional mitral regurgitation, or combinations thereof.

According to some embodiments, there is provided herein a coupling element comprising a wire comprising a memory shape material configured to assume a shape of a spiraled coupling element; wherein the spiraled coupling element comprises a first spiral and a second spiral interconnected by an essentially straight wire; wherein a distal end of the first end forms the innermost loop of the first spiral, and a proximal end of the first end forms the outermost loop of the first spiral; and wherein a distal end of the second end forms the outermost loop of the second spiral and a proximal end of the second end forms the innermost loop of the second spiral. According to some embodiments, the terms attachment element and coupling element may be interchangeably used and may refer to any element configured to connect the supra mitral device to the valve. For example, according to some embodiments, the coupling element may be soft to the touch, or soft on its contact surfaces. According to some embodiments, the coupling element may be elastic in order to provide spring-like / shock-absorbing characteristics, with a strong yet elastic central core. The coupling element(s) may be configured to attach the supra-mitral supra mitral device to the leaflets of a mitral valve. The first and second spirals may be positioned on opposite sides of the supra mitral device and mitral leaflet, when attached. The coupling element(s) may include featherlike enveloping fibers configured to cushion its touch on the tissue, as well as to form a skeleton for clots and tissue formation. According to some embodiments, the coupling element is configured to be horizontal relative to the valve plane (e.g., conus shapes). According to some embodiments, the coupling element is configured to be vertical relative to the valve plane ((e.g., the spiral elements). According to some embodiments, the coupling element may include a horizontal section adapted for positioning above the supra mitral device plane and a vertical section adapted for positioning below the leaflet plane. The vertical section is designed not to interfere with the function of the untorn chordae.

Transcatheter Mitral Valve Repair (TMVRr) for Secondary MR-Functional Mitral Regurgitation (FMR):

According to some embodiments, there is thus provided herein, a device and method for mitral valve repair in a subject suffering from FMR. The device includes a supra mitral supra mitral device having essentially annular D-shape with an eccentric opening, such that a posterior section of the supra mitral device is wider than an anterior

section of the supra mitral device, the posterior section of the supra mitral device configured for coverage and attachment to essentially the entire circumference of the mitral leaflet, while extending above the posterior leaflet, without being attached at all to its inner part, and further extend to (significantly) overlap at least a portion of the posterior inner margins of the anterior leaflet of the mitral valve, thereby preventing and/or reducing mitral regurgitation, wherein the section of the posterior section of the supra mitral device which is configured to overlap and cover partially the anterior leaflet is made of a pliable material, adapted to stiffen after implantation of the device. According to some embodiments, in an FMR version of the device, there is no need for the device to follow the movements of the posterior leaflet -it actually substitutes the posterior leaflet at the annular level serving as posterior mitral leaflet augmentation, while the overlapping skirt over the anterior leaflet performs a reverse coaptation between the anterior and posterior leaflets.

According to some embodiments, the part of the posterior section of the supra mitral device that is configured to overlap at least a portion of the anterior leaflet may be made of a less traumatic material (like PTFE/Gortex^R or treated pericard) than the rest of the supra mitral device.

According to some embodiments, the device is configured to be coupled to the circumference of the mitral valve, and configured to be coupled to (for example, by at least two inner coupling elements) to P1 and to P3 posterior leaflet segments. These are the less-tethered areas of the valve leaflets. Further LV remodeling causes stronger tethering, which then effects P1 and P3 more and more, pulling the augmented posterior leaflet down with them, thus preserving its coaptation with the anterior leaflet at least for an extended time of continuing LV remodeling.

According to some embodiments, the device does not include annuloplasty. However, its immobilization of the whole mitral circumference prevents further annular dilatation.

According to some embodiments, there is further provided herein a deployment tool configured to hold the supra mitral device in its folded configuration within a catheter and when the deployment tool with the folded device emerges from the catheter above the mitral valve, the deployment tool is configured to unfold the supra mitral

device and to adjust it to its final position on the mitral valve. The deployment tool will be removed or detached after the device is attached to the leaflets. According to some embodiments, the deployment tool may have a form of an umbrella having a plurality of arms (such as 3-5, 4-6 or 5-8). The umbrella may have at least two configurations: a
5 close configuration for holding the folded device within the catheter and an open configuration for deploying the device and adjusting the deployed device in its desired location and position.

According to some embodiments, there is further provided herein an attachment tool for providing the coupling elements to attach the supra mitral devices to the valve
10 leaflets. According to some embodiments, the attachment tool is configured to facilitate the coupling of the supra mitral device to the valve leaflets when the device is held by a deployment tool (such as the umbrella type deployment tool).

According to some embodiments, the attachment tool may also have an umbrella structure. The umbrella like attachment tools may be configured to attach the
15 coupling elements from the umbrella ribs (arms).

According to some embodiments, the attachment tool may be a part of the deployment tool. For example, the deployment tool may have a main umbrella structure, and the attachment tool may have a secondary umbrella structure (for example, inserted through the central pole of the main umbrella).

20 According to some embodiments, the attachment tool may be a separate tool, formed and or functioning independently from the deployment tool.

According to some embodiments, any one of the attachment tools disclosed herein may be one by one loaded with coupling elements or loaded with a cartridge of coupling elements. The cartridge of coupling elements may include separate coupling
25 elements or a line (such as a wire) from which the coupling elements are produced (e.g., cut) during the process of valve repair.

According to some embodiments, there is provided herein a supra mitral device for mitral/tricuspid valve repair in a subject in need thereof, the device comprising a main body portion having essentially annular D-shape with an eccentric opening, such
30 that a posterior section of the main body portion is wider than an anterior section of the

main body portion, the posterior section of the main body portion configured for coverage and attachment to essentially the whole section of the posterior leaflet of the mitral valve which faces the left atrium on systole, thereby preventing and/or reducing mitral regurgitation, wherein the posterior section of the main body portion is made of
5 a pliable material, adapted to stiffen after implantation of the device. According to some embodiments, the subject may suffer from mitral insufficiency. The mitral insufficiency may include fibroelastic deficiency, myxomatous mitral valve, functional mitral regurgitation (FMR), or combinations thereof. According to some embodiments, the supra mitral device may be configured for trans-catheter implantation.

10 According to some embodiments, “essentially the whole section of the posterior leaflet of the mitral valve which faces the left atrium on systole” may refer to over 80% of the section of the posterior leaflet of the mitral valve which faces the left atrium on systole, over 90% of the section of the posterior leaflet of the mitral valve which faces the left atrium on systole, over 95% of the section of the posterior leaflet of the mitral
15 valve which faces the left atrium on systole or between 80-95% of the over 90% of the section of the posterior leaflet of the mitral valve which faces the left atrium on systole.

According to some embodiments, the posterior section of the main body portion is configured to stay attached/adherent/bonded to the posterior leaflet throughout the cardiac cycle, eventually maintaining/immobilizing the posterior leaflet at an
20 essentially permanently elevated/closed position.

According to some embodiments, the posterior section of the main body portion is attached to the posterior leaflet while assuming a shape of the posterior leaflet.

According to some embodiments, the main body portion is not directly attached to an annulus of the mitral valve.

25 According to some embodiments, the main body portion may further include a plurality of through holes for securing the device to the mitral valve leaflet.

According to some embodiments, the pliable material may include felt and/or, cloth, woven or knitted. The felt may include Teflon™, Dacron™, PTFE (Gortex™), or any combination thereof.

According to some embodiments, the main body portion has a stiffness gradient between an outer and an inner perimeter thereof.

According to some embodiments, the supra mitral device may further include an enforcement element extending along an inner perimeter of the main body portion.

5 According to some embodiments, the supra mitral device may further include an enforcement element extending along at least a part of an inner perimeter of the main body portion configured to support a particular location of the posterior leaflet where a leakage occurs.

10 According to some embodiments, the posterior section of the main body portion is configured to extend beyond the area of the posterior leaflet and thus to overlap a portion of an anterior mitral leaflet, thereby preventing/reducing mitral regurgitation.

15 According to some embodiments, the main body portion may further include an extension, contiguous with or attached to the posterior section and configured to extend beyond the area of the posterior leaflet and thus, when implanted, to overlap with a posterior part of an anterior leaflet, thereby preventing/reducing mitral regurgitation. The extension may be made of a less traumatic material than that of the posterior section.

20 According to some embodiments, there is provided herein a coupling element comprising a wire comprising a memory shape material configured to assume a spiral shape; wherein the spiral comprises a first spiral and a second spiral interconnected by an essentially straight wire; wherein a distal end of the first end forms the innermost loop of the first spiral, and a proximal end of the first end forms the outermost loop of the first spiral; and wherein a distal end of the second end forms the outermost loop of the second spiral and a proximal end of the second end forms the innermost loop of the
25 second spiral.

30 According to some embodiments, there is provided herein a coupling element comprising a wire comprising a memory shape material configured to assume a spiral shape; wherein the spiral comprises a first spiral and a second spiral interconnected by an essentially straight wire; wherein a distal end of the first end forms the outermost loop of the first spiral, and a proximal end of the first end forms the innermost loop of

the first spiral; and wherein a distal end of the second end forms the innermost loop of the second spiral and a proximal end of the second end forms the outermost loop of the second spiral.

5 According to some embodiments, there is provided herein the coupling element which may be configured to attach the supra-mitral main body portion disclosed herein or any other supra-mitral device to the leaflets of a mitral valve. The first and second spirals may be positioned on opposite sides of the main body portion and mitral leaflet, when attached.

10 According to some embodiments, the coupling element may include featherlike enveloping fibers configured to cushion its touch on the tissue, as well as to form a skeleton for clots and tissue formation.

15 According to some embodiments, there is provided herein a method of Percutaneous Mitral Valve Repair or Replacement (PCMVR), the method comprising attaching a supra mitral device disclosed herein or any other supra mitral device, supra mitrally, to a posterior leaflet along its outer and inner margins, thus coupling the device to the entire posterior mitral leaflet section that faces the left atrium on systole, and to the anterior leaflet at its outer margins only, thus completing attachment of the main body portion to the circumference of the mitral valve. Attaching may include using multiple coupling elements disclosed herein or other appropriate coupling elements.

20 According to some embodiments, the method may further include a later second stage step, if residual mitral regurgitation is deemed unacceptable on follow-up, to exploit the device as a docking system for per-catheter mitral valve replacement.

25 According to some embodiments, there is provided herein a method of Percutaneous Mitral Valve Repair or Replacement (PCMVR), the method includes supra mitrally attaching the device disclosed herein to a posterior leaflet along its outer and inner margins, thus coupling the device to the entire section of the posterior mitral leaflet, which faces the left atrium, and to the anterior leaflet at its outer margins only, thus completing attachment of the supra mitral device to all of the circumference of the mitral valve leaflets.

According to some embodiments, there is provided herein a method of Per Cutaneous Mitral Valve Repair or Replacement (PCMVR), the method includes supra mitrally attaching the device disclosed herein to all of the circumference only of the mitral valve leaflets, while the posterior leaflet along its inner margins as well, by either
5 a second line of small coupling elements along its inner margins, or employing large coupling elements (for example, 8-15 mm diameter) along the posterior leaflet (mostly along its middle segment, the P2) this way, coupling the device to the entire section of the posterior mitral leaflet which faces the left atrium on systole, and to the anterior leaflet at its outer margins only (so this way the anterior leaflet retains its movement
10 range near normal).

The method may further include a second, later step of employing the device as a docking system for per-catheter mitral valve replacement, if residual mitral regurgitation is deemed unacceptable on follow-up.

According to some embodiments, there is provided herein a method of Per
15 Cutaneous Mitral Valve Repair or Replacement (PCMVR). The method includes supra mitrally attaching the device (supra mitral device) disclosed herein to the outer margin of the whole mitral valve circumference, while in the posterior leaflet along its outer and inner margins, thus coupling the device to essentially the entire section of the posterior mitral leaflet, which is facing the atrium. The method may further include
20 employing the device as a docking system for per-catheter mitral valve replacement, wherein the supra mitral device is used as a docking system for mitral valve replacement are performed at the same single procedure. Attachments may include using multiple coupling elements/rivets as disclosed herein.

According to some embodiments, there is provided herein a method of Per
25 Cutaneous Mitral Valve Repair or Replacement (PCMVR), for both primary (Degenerative) and secondary (Functional) mitral regurgitation. The method includes the steps of:

- a. Inserting the deployment and attachment tools Transcatheter Percutaneously (separately or combined, according to the tools
30 configuration): Trans- venous for trans-septal approach to the left atrium and mitral valve, Trans- arterial for retrograde approach through a large

- vessel to the aorta, aortic valve, left ventricle and mitral valve. Trans-apical approach may be employed in early models.
- b. Introducing the deployment tool into the left atrium just above the mitral valve. The deployment tool contains the device folded on it.
- 5 c. The deployment tool unfolds the device above the mitral valve circumference.
- d. Aligning the device above the mitral valve: Both the mitral valve and the device are asymmetric: "D" shaped-like. The device is rotated to align the device above the mitral valve to its final alignment. The D shaped form of the device will be aligned to the D shape form of the mitral valve.
- 10 e. The device is positioned to cover the whole mitral valve, above its all circumference. The device asymmetric fenestration positioned to cover most of the anterior leaflet, except its base (close to the annulus, along the aortic-mitral continuity). The device is now ready to be attached.
- 15 f. The attachment tool (for, example, according to embodiments disclosed herein) is ready to attach the device to the mitral valve leaflets. The attachment tool is loaded with coupling elements, single or multiple configuration.
- 20 g. The attachment tool is attaching the device to the mitral valve leaflets by inserting the coupling elements all around the mitral circumference on the leaflets themselves (near, but not on, the annulus). The trigger to the coupling tool for inserting a coupling element in order to attach the device to the mitral leaflet is synchronized to the ventricular systole.
- 25 During the systole, the high left ventricular pressure keeps the leaflets up and tense to support the insertion by giving an opposite stabilizing force.
- h. The insertion has three stages: First insert the coupling element to penetrate the device and mitral leaflet. The tip starts immediately to coil into a spiral below the mitral leaflet. Second the interventional cardiologist should decide whether the coupling element is well inserted and positioned: If not, the coupling element can still be retrieved by simply pulling by the coupling tool, then repeating the insertion process.
- 30 If well inserted, the interventional cardiologist further releases the

coupling element from the insertion tool. The upper/proximal part of the coupling element starts immediately to spiral above the device (in the left atrium). The two spirals are now attaching the device and leaflet. If the interventional cardiologist wishes then to retrieve the coupling elements, it might still be possible. When the interventional cardiologist approves this insertion step, the coupling element is detached from the attachment tool. The same procedure may be repeated with the next coupling elements as required. This technique may be used to insert a line or two lines of coupling elements along all of the mitral valve circumference (perimeter). According to some embodiments, the interventional cardiologist may have different sizes and types of coupling elements and may decide what sizes and types to use, as well as their number, and whether to put them in one line or two lines, to achieve complete immobilization of the posterior leaflet part facing the left atrium.

According to some embodiments, there is provided herein a kit for Percutaneous Mitral Valve Repair or Replacement (PCMVR), the kit comprising: a supra mitral device, disclosed herein in accordance with some embodiments; and a plurality of coupling elements, disclosed herein in accordance with some embodiments, configured to attach the main body portion to the leaflet of the mitral valve.

According to some embodiments, the plurality of coupling elements may include a memory shape material configured to assume a shape of a spiral. The coupling element may include a first spiral and a second spiral interconnected by an essentially straight wire.

According to some embodiments, the coupling element may be configured to be positioned horizontal relative to the valve plane and is formed of a wire having a first end and a second end; the first end forming the first spiral and the second end forming the second spiral; wherein a distal end of the first end forms the outermost loop of the first spiral, and a proximal end of the first end forms the innermost loop of the first spiral; and wherein a distal end of the second end forms the innermost loop of the

second spiral and a proximal end of the second end forms the outermost loop of the second spiral.

According to some embodiments, the coupling element may be configured to be positioned vertical relative to the valve plane and is formed of a wire having a first end and a second end; the first end forming the first spiral and the second end forming the second spiral; wherein a distal end of the first end forms the innermost loop of the first spiral, and a proximal end of the first end forms the outermost loop of the first spiral; and wherein the distal end of the second end forms the outermost loop of the second spiral and a proximal end of the second end forms the innermost loop of the second spiral.

According to some embodiments, the first and second spirals may be positioned on opposite sides of the main body portion and mitral leaflet, when attached.

According to some embodiments, the kit may further include an artificial valve.

According to some embodiments, the kit may further include a deployment tool (for example, as disclosed herein in accordance with some embodiments) configured to deploy the supra mitral device and to adjust it to its final position on the mitral valve.

According to some embodiments, the kit may further include an attachment tool (for example, as disclosed herein in accordance with some embodiments) configured to provide the coupling elements.

Certain embodiments of the present disclosure may include some, all, or none of the above advantages. One or more technical advantages may be readily apparent to those skilled in the art from the figures, descriptions and claims included herein. Moreover, while specific advantages have been enumerated above, various embodiments may include all, some or none of the enumerated advantages.

In addition to the exemplary aspects and embodiments described above, further aspects and embodiments will become apparent by reference to the figures and by study of the following detailed descriptions.

BRIEF DESCRIPTION OF THE DRAWINGS

Examples illustrative of embodiments are described below with reference to figures attached hereto. In the figures, identical structures, elements or parts that appear in more than one figure are generally labeled with a same numeral in all the figures in which they appear. Alternatively, elements or parts that appear in more than one figure may be labeled with different numerals in the different figures in which they appear. Dimensions of components and features shown in the figures are generally chosen for convenience and clarity of presentation and are not necessarily shown in scale. The figures are listed below.

10 **FIG. 1** schematically illustrates the mitral valve region;

FIG. 1A schematically illustrates a top view of a supra mitral device for transcatheter mitral valve repair, according to some embodiments;

FIG. 1B schematically illustrates a top view of the valve leaflets without the supra mitral device, according to some embodiments;

15 **FIG. 1C** schematically illustrates a top view of the supra mitral device illustrated in Fig. 1A, also depicting the valve leaflets seen below the supra mitral device, according to some embodiments;

FIG. 1D schematically illustrates a top view of the supra mitral device illustrated in Fig. 1A, also depicting the attachment/coupling element, according to
20 some embodiments;

FIG. 1E schematically illustrates a top view of the “horse shoe” shaped supra mitral device and depicting the attachment/coupling element, according to some embodiments;

FIG. 1F schematically illustrates a top view of the supra mitral device of Fig.
25 1E, and also depicting the valve leaflets seen below the supra mitral device, according to some embodiments;

FIGS. 1G I-VIII schematically illustrate different variations of supra mitral devices, according to some embodiments;

FIG. 2 schematically illustrates a vertical coupling element during its transformation from a straight wire to a double spiraled vertical coupling element; according to some embodiments;

FIGS. 3A-C schematically illustrate horizontal coupling elements, according to
5 some embodiments;

FIGS. 4A-E schematically illustrate single, triple and quadruple double spiraled vertical coupling elements, according to some embodiments;

FIG. 5 schematically illustrates a combined coupling element including a two-sided lower vertical spiral and an upper horizontal spiral, according to some
10 embodiments;

FIG. 6 schematically illustrates a supra mitral device for trans catheter mitral valve repair attached to the leaflets of a mitral valve using a plurality of coupling elements, according to some embodiments;

FIGS. 7A-L schematically illustrate “umbrella” type supra mitral device
15 deployment tools, according to some embodiments;

FIG. 8 schematically illustrates the mitral valve region and the LV after posterior wall myocardial infarction (MI) in diastole;

FIG. 9 schematically illustrates the mitral valve region and the LV after posterior wall MI in systole;

FIG. 10 schematically illustrates papillary muscle displacement post MI (R. A. Levine, E. Schwammenthal: *Circulation*. 2005;112:745-758);
20

FIG. 11 schematically illustrates a view of the mitral valve from the LA in systole;

FIG. 12 schematically illustrates an undersized ring repair according to the prior
25 art (Steven Bolling);

FIG. 13 schematically illustrates an undersized ring repair late MR recurrence;

FIG. 14 schematically illustrates an intra-operative picture of prior art posterior leaflet augmentation for FMR in human patients (S. Mitsuyama et al.: Mitral Valve Repair by Posterior Leaflet Augmentation for Ischemic Mitral regurgitation. In: AATS Mitral Conclave; Breakout Session 9: Surgery for Ischemic Mitral Regurgitation, Thursday, April 27, 2017);

FIG. 15 illustrates a schematic view of the mitral valve from the LA in systole FMR;

FIG. 16 schematically illustrates a supra mitral device and the coupling thereof (marked by + and *), according to some embodiments;

FIG. 17 schematically illustrates the supra mitral device used in FMR, according to some embodiments;

FIG. 18 schematically illustrates the supra mitral device for FMR, according to some embodiments;

FIG. 19 schematically illustrates the supra mitral device for FMR and coupling thereof, according to some embodiments;

FIG. 20 schematically illustrates a supra mitral device for FMR and coupling thereof, according to some embodiments;

FIG. 21 schematically illustrates two types of supra mitral devices, according to some embodiments; and

FIGS. 22 I-IV schematically illustrate different variations of supra mitral devices for use in FMR, according to some embodiments.

DETAILED DESCRIPTION

In the following description, various aspects of the disclosure will be described. For the purpose of explanation, specific configurations and details are set forth in order to provide a thorough understanding of the different aspects of the disclosure. However, it will also be apparent to one skilled in the art that the disclosure may be practiced

without specific details being presented herein. Furthermore, well-known features may be omitted or simplified in order not to obscure the disclosure.

According to some embodiments, there is provided a device for mitral valve repair in a subject in need thereof, the device comprising a supra mitral device having an essentially annular D-shape and an eccentric opening, such that a posterior section of the supra mitral device is wider than an anterior section of the supra mitral device.

According to some embodiments, as used herein, the term "supra mitral device" refers to a soft plate-like device configured for attachment to the leaflets of the mitral valve. Attachment of the supra mitral device to the posterior leaflet of the mitral valve prevents and/or minimizes mitral regurgitation. According to some embodiments, the posterior section of the supra mitral device is configured for attachment to a part of the posterior leaflet, which is facing the atrium. According to some embodiments, the anterior section of the supra mitral device is configured for attachment only to the part of the anterior leaflet of the mitral valve closest to the base of the anterior leaflet, at the aortic-mitral continuity level.

According to some embodiments, at least the posterior section of the supra mitral device is made of a pliable material, anticipated to stiffen slowly after implantation of the device. The pliability advantageously enables the supra mitral device to adopt the anatomical shape of the leaflet tissue, thereby preserving the relation of the leaflet to the untorn chords so that during every systole all the chords will be stretched to their pre-procedural length in which they functioned efficiently and take their fair part of the work load. The coupling of the supra mitral device to the leaflets means the supra mitral device moves with the leaflets, thus it hinders the leaflet from striking the supra mitral device during the dynamics of the cardiac cycle. Furthermore, the initial flexibility of the device enables it to assume a collapsed configuration suitable for delivery through a catheter. According to some embodiments, the pliable material comprises felt, typically made of Teflon™/Dacron™/ PTFE (Gortex™), and the like, and/or woven or knitted cloth.

According to some embodiments, the supra mitral device is supra mitral, i.e. is configured to be attached to the mitral valve from the aspect of the leaflet facing the

left atrium. According to some embodiments, the supra mitral device is configured to expand into its desired configuration upon its delivery into the left atrium.

According to some embodiments, the supra mitral device is configured to stay attached and bonded to the leaflets throughout the cardiac cycle and move with them, thereby hindering the leaflet from hitting the supra mitral device during systole. According to some embodiments, attachment of the supra mitral device to the posterior leaflet, eventually with time, maintains the leaflet in an essentially permanently elevated/closed position. It is thus understood that attachment of the supra mitral device causes the opening of the mitral valve to be constituted by anterior leaflet only. According to some embodiments, part of the mitral valve opening remains closed as a result of supra mitral device attachment to the posterior leaflet rim and free margin. According to some embodiments, 10%-50% of the mitral valve opening remains closed/ineffective as a result of supra mitral device attachment when the valve is in its open position (during diastole). This can be considered a kind of "one leaflet mitral valve repair", which is applied in many techniques of surgical mitral valve repairs.

According to some embodiments, the supra mitral device is configured to be attached to the valve tissue. According to some embodiments, the supra mitral device is not attached directly to a muscle tissue. According to some embodiments, the supra mitral device is not directly attached to the annulus of the mitral valve. This is highly advantageous in that attachment of the supra mitral device to the annulus may inevitably cause uneven tension distribution along the leaflets, thus, in turn, may cause tearing forces and ineffective supra mitral device coupling.

According to some embodiments, the terms attach/attached/attachment and couple/coupled/coupling may be used interchangeably.

According to some embodiments, the supra mitral device is formed of a material which enables penetration of coupling elements. According to some embodiments, the device includes a plurality of coupling elements configured to attach the supra mitral device to the posterior and anterior leaflets of the mitral valve. According to some embodiments, the coupling elements may be an integral part of the supra mitral device. Alternatively, the coupling elements may be stand-alone elements configured to penetrate the supra mitral device and bring about its attachment/coupling to the leaflets

of the mitral valve. As used herein, the term "plurality" with regards to coupling elements may refer to at least 2, at least 3, at least 4, at least 10 or at least 15 coupling elements. Each possibility is a separate embodiment.

As used herein the term "coupling element" may refer to any element configured to accomplish the attachment/coupling/bonding/securing/affixing of the supra mitral device to the leaflets of the mitral valve. According to some embodiments, the coupling element may include staples, straps, hooks, screws, pins, bolts, rivets, or any other suitable coupling element or combination of coupling elements. According to some embodiments, the coupling element includes a memory shape material configured to assume the shape of a coiled coupling element or spiral coupling element, as further elaborated hereinbelow. According to some embodiments, the term "coupling element" refers to a mechanical fastener including a shaft (e.g. a straight wire or cylinder) with fastening elements at each end. According to some embodiments, the coupling element may initially have a form of a straight wire configured to penetrate the supra mitral device and the leaflet. After penetration, the wire folds into a predetermined dumbbell-like configuration which holds the coupling element in place. According to some embodiments, the predetermined shape of the coupling element may be in the form of two horizontal (parallel to the leaflets) spirals or vertical (perpendicular to the leaflets) spirals connected by a straight wire. According to some embodiments, the wires twist into spirals which are positioned on opposite sides of the supra mitral device and of the posterior leaflet, when attached. According to some embodiments, the wires twist into spirals which are vertically positioned relative to the straight wire (the spirals). According to some embodiments, the spirals may be horizontally positioned (the cones) right angled to the connecting straight wire. According to some embodiments, one of the spirals may be horizontally positioned and the other vertically positioned relative to the straight wire. According to some embodiments, the predetermined shape of the coupling element may include two double spirals separated by a straight wire.

According to some embodiments, the wire forming the coupling element has a first end and a second end, wherein the first end forms the first spiral and the second end forms the second spiral. According to some embodiments, the distal end of the first end forms the outermost loop of the first spiral, whereas the proximal end of the first end forms the innermost loop of the first spiral. Similarly, the distal end of the second

end forms the innermost loop of the second spiral, whereas the proximal end of the second end forms the outermost loop of the second spiral. This advantageously prevents tearing of the tissue to which it is attached when a pull force is applied at either end of the coupling element, as it has a spring like spiral configuration which absorbs the
5 pulling force.

According to some embodiments, the coupling element is configured to be vertical relative to the valve plane and is formed of a wire having a first end and a second end; the first end forming the first spiral and the second end forming the second spiral; wherein a distal end of the first end forms the innermost loop of the first spiral,
10 and a proximal end of the first end forms the outermost loop of the first spiral; and wherein a distal end of the second end forms the outermost loop of the second spiral and a proximal end of the second end forms the innermost loop of the second spiral.

According to some embodiments, the device is suitable for use in a subject suffering from mitral insufficiency resulting from fibro-elastic deficiency, myxomatous
15 mitral valve, functional mitral regurgitation, or combinations thereof. Each possibility is a separate embodiment.

According to some embodiments, the coupling element is configured to attach a supra mitral device to a posterior leaflet of a mitral valve and the anterior leaflet, as essentially described herein.

20 According to some embodiments, the first and second spirals are positioned on opposite sides of the supra mitral device, when attached, as essentially described herein.

Reference is now made to **FIG. 1**, which schematically depicts the mitral valve region and operation (during systole and diastole). The following numbers depict the respective parts in the valve region:

- 25 1- Posterior mitral leaflet;
 2- Chordae;
 3- Anterior mitral leaflet;
 4- Chordae;
 5- Papillary muscles; and
30 6- Aortic valve

Reference is now made to **FIG. 1A-F**, which schematically illustrate top and perspective views respectively, of a supra mitral device **100** for trans-catheter mitral valve repair, according to some embodiments. Supra mitral device **100** has an essentially annular, D shape and an eccentric opening **110**, the opening located such that a posterior (marked as “P”) section **120** of supra mitral device **100** is wider than an anterior (marked as “A”) section **122** of supra mitral device **100**.

FIG. 1B schematically illustrates a top view of a valve **124** without a supra mitral device, according to some embodiments. Valve **124** has an anterior leaflet **124a** and a posterior leaflet which has three sections depicted as **P1**, **P2** and **P3**. **FIG. 1C** schematically illustrates a top view of the supra mitral device illustrated in **Fig. 1A** and also depicting the leaflets of valve **124** seen below the supra mitral device, according to some embodiments. Supra mitral device **100** is configured for attachment to the leaflets of the mitral valve at the aspect facing the atrium such that opening **110** at least partially lines the opening of the anterior leaflet of the mitral valve as shown in **FIG. 1C**.

Attachment of supra mitral device **100** to the posterior leaflet of the mitral valve prevents and/or mitigates flailing of mitral segments, thus minimizing mitral regurgitation. Posterior section **120** of supra mitral device **100** is configured for attachment to the posterior leaflet of the mitral valve, and anterior section **122** of supra mitral device **100** is configured for attachment to the part of the anterior leaflet of the mitral valve closest to the base of the anterior leaflet, at the aortic-mitral continuity (AMC) region as seen in **FIG. 1**.

At least posterior section **120** of supra mitral device **100** (optionally the entire supra mitral device **100**) is made of a pliable material, adapted to slowly stiffen after implantation thereof. This advantageously enables supra mitral device **100** to adopt the anatomical shape of the leaflet tissue, thereby preventing the leaflet from striking against supra mitral device **100** during the dynamics of the cardiac cycle. Similarly, supra mitral device **100** is configured to stay attached/adhered/bonded to the posterior leaflet throughout the cardiac cycle, thereby preserving the relation of the leaflet to the non-torn chords' length, such that during every systole all the non-torn chords will be stretched to their proper length and take their fair share of the work load. The coupling of the supra mitral device to the leaflets means that the supra mitral device moves with

the leaflets, thus it hinders the leaflets from striking against the supra mitral device during the dynamics of the cardiac cycle during the systole.

Opening **110** is defined by an inner perimeter **115** of supra mitral device **100**. According to some embodiments, inner perimeter **115** may be configured to provide support to the leaflets of valve **124**. According to alternative or additional embodiments, inner perimeter **115** may be configured to provide docking to an artificial valve.

According to some embodiments, supra mitral device **100** is configured to be attached supra mitrally, i.e. on the aspect of the leaflet facing the left atrium.

According to some embodiments, supra mitral device **100** has a collapsed configuration (not shown) enabling its delivery through a catheter.

FIG. 1D schematically illustrates a top view of the supra mitral device illustrated in Fig. 1A, which also depicts the attachment/coupling element, according to some embodiments. The stars (***) represent the location of the coupling elements connecting the outer circumference of the supra mitral device to the leaflets of the mitral valve all around. The small circles (ooo) represent the location of the coupling elements connecting the inner margin of the posterior section of the supra mitral device to the inner margins of the posterior leaflet of the mitral valve.

FIG. 1D' schematically illustrates a top view of the supra mitral device illustrated in **Fig. 1A**, which also depicts the attachment/coupling element, according to some embodiments. The small stars (***) represent the location of the coupling elements connecting the outer circumference of the supra mitral device to the leaflets of the mitral valve at the anterior section of the supra mitral device. The large stars (**121**) represent the location of larger coupling elements (relative to the smaller coupling elements represented by the small stars (***)) connecting the posterior section of the supra mitral device to the posterior leaflet of the mitral valve. Employing large coupling elements on the posterior mitral leaflet, enables one line of coupling elements (as opposed to **Fig. 1D**) and optionally fewer coupling elements.

Reference is now made to **FIG. 1E**, which schematically illustrates a top view of the “horse shoe” shaped supra mitral device and depicting the attachment/coupling element, according to some embodiments and to **FIG. 1F**, which schematically illustrates a top view of the supra mitral device of **Fig. 1E**, and also depicting the valve
5 leaflets seen below the supra mitral device, according to some embodiments.

Supra mitral device **100'** has essentially a “horse shoe” shape **110'**, having only a posterior (marked as “P”) section **120'** where an anterior (marked as “A”) section is missing. Supra mitral device **100'** has an inner perimeter **115'**. According to some
10 embodiments, inner perimeter **115'** may be configured to provide support to the posterior leaflet of valve **124**. According to alternative or additional embodiments, inner perimeter **115'** may be configured to provide docking to an artificial valve.

It is understood that embodiments of this disclosure include a supra mitral device such as supra mitral device **100**, where the anterior section is partial or incomplete, such that the supra mitral device has a form of an unclosed ring (opened
15 perimeter where the two ends of the supra mitral device are not joined), or any other shape which is configured for attachment to the posterior leaflet of the mitral valve.

Reference is now made to **FIGS. 1G I-VIII**, which schematically illustrate different variations of supra mitral devices, namely devices **150, 155, 160, 165, 170, 175, 180** and **185** respectively, according to some embodiments. Devices **150, 155, 160**
20 and **165 (FIGS 1G I-IV)** are configured for posterior mitral leaflet (P) immobilization without overlapping the anterior leaflet (A). According to some embodiments, devices **150, 155, 160** and **165**, have a shape similar to that of device **100** (of **Fig 1A-D**) and are configured for attachment to the posterior leaflet (P) of the mitral valve. Devices **150, 155, 160** and **165** have an anterior section **177/178** configured for attachment to a
25 narrow strip at the base of the anterior leaflet of the mitral valve. Anterior section **177** has a unified softness, while anterior section **178** has a gradual softness, for example becoming softer from the external “ring” part to the internal “ring” part. Devices **150, 155, 160** and **165** have a posterior section **151/153** configured for attachment to the
30 posterior leaflet (P) of the mitral valve. According to some embodiments, posterior section **151** has a unified softness, while posterior section **153** has a gradual softness, for example becoming softer from the external “ring” part to the internal “ring” part. According to some embodiments, devices **155** and **165**, further have a local

enforcement element **156** to support the particular location of the posterior leaflet where the leakage occurs.

Devices **170, 175, 180** and **185 (FIGS 1G V-VIII)** are configured for posterior mitral leaflet (P) immobilization with some extra width to overlap a narrow strip at the inner margin of the anterior mitral leaflet.

According to some embodiments, devices **170, 175, 180** and **185**, have a shape similar to that of device **100** (of **Fig 1A-D**) and are configured for attachment to the posterior leaflet (P) of the mitral valve. Like devices **150, 155, 160** and **165**, devices **170, 175, 180** and **185**, have an anterior section **177/178** configured for attachment to a narrow strip at the base of the anterior leaflet of the mitral valve. However, unlike devices **150, 155, 160** and **165**, devices **170, 175, 180** and **185** have a posterior section **171/173** configured for attachment to the posterior leaflet (P) of the mitral valve with some extra width (**172**) along an inner part thereof, to overlap a narrow strip at the inner margin of the anterior mitral leaflet. According to some embodiments, posterior section **171** has a unified softness, while posterior section **173** has a gradual softness, for example, becoming softer from the external “ring” part to the internal “ring” part. Like devices **150, 155, 160** and **165**, devices **170, 175, 180** and **185** may further have a local enforcement element **176** to support the particular location of the posterior leaflet where the leakage occurs.

According to some embodiments. devices **150, 155, 160, 165, 170, 175, 180** and **185** have two modes: open mode and close mode. When the devices are inside the catheter they are in a close mode, for example, attached to an umbrella device folded to their close mode. When the deployment tool, such as the umbrella with the folded device, emerges from the catheter above the mitral valve, the deployment tool, such as the umbrella, opens and the supra mitral device unfolds. The deployment tool, such as the umbrella, is configured to hold and adjust the device in its final position on the mitral valve. The deployment tool, such as the umbrella, will be removed or detached after attaching the device to the leaflets. Devices **150, 155, 160, 165, 170, 175, 180** may be made of one or more layers. Devices **150, 155, 160, 165, 170, 175, 180** may be made of one or more knitted Dacron like materials and/or other least traumatic materials (Pericard, Gortex, Gortex like or any other appropriate material).

Reference is now made to **FIG. 2**, which schematically illustrates a vertical coupling element **200** during its folding from a straight wire (step 1) to a double coiled vertical spiral coupling element (step 4); according to some embodiments. During delivery, coupling element **200** is a straight wire **210** (step 1). Subsequently, a first end **201** of wire **210** spirals into a first vertical spiral **220** (steps 2 and 3). In its straight or first end coiled configuration, coupling element **200** may penetrate the surfaces to be attached, such as, but not limited to, the supra mitral device and the posterior leaflet of the mitral valve, here illustrated as surfaces **250** and **252**. After penetration, the second end **202** of wire **210** folds into a second vertical spiral **230** (step 4) such that first vertical spiral **220** and second vertical spiral **230** are positioned on opposite sides of surfaces **250** and **252** (step 4). First and second vertical spirals **220** and **230** are folded such that a distal end of first end **201** forms the innermost loop **224** of first vertical spiral **220**, and a proximal end of first end **201** forms the outermost loop **226** of first vertical spiral **220**. Similarly, a distal end of second end **202** forms the outermost loop **234** of second vertical spiral **230** and a proximal end of second end **202** forms the innermost loop **236** of second vertical spiral **230**. This advantageously provides shock-absorbing quality of the coils to lessen direct forces exerting tearing effects on the delicate surfaces (e.g. tissue) to which it is attached when a pull force is applied at either end of the coupling element. Optionally, the diameter of wire **210** may be gradually decreasing toward ends **201** and **202** thereof, thereby easing the folding into spirals **220** and **230**.

Reference is now made to **FIGS. 3A-C**, which schematically illustrate a horizontal coupling element, according to some embodiments. During delivery, coupling element **300** is a wire **310**, which folds into a first horizontal spiral **320** and subsequently, after penetrating the surfaces to be attached, such as, but not limited to, the supra mitral device and the posterior leaflet of the mitral valve, here illustrated as surfaces **350** and **352** (**FIG. 3B**), into a second horizontal spiral **330** such that first horizontal spiral **320** and second horizontal spiral **330** are positioned on opposite sides of surfaces **350** and **352**. First and second horizontal spirals **320** and **330** are folded such that a distal end of the part of the wire forming first spiral **320** forms the outermost loop **326** and a proximal end the part of the wire forming first spiral **320** forms the innermost loop **324** of first vertical spiral **220**. Similarly, a distal end of the part of the wire forming second spiral **330** forms the innermost loop **334** and a proximal end of the part of the wire forming second spiral **330** forms the outermost loop **336**. This advantageously

prevents tearing of the delicate surfaces (e.g. tissue) to which it is attached when a pull force is applied at either end of the coupling element. Optionally, the diameter of wire **310** may be gradually decreasing toward its ends, thereby easing the folding into spirals **320** and **330**. **FIG. 3B** shows the contact area **337** of outermost loop **326** of first vertical spiral **320** of horizontal coupling element **300** with the valve leaflet **352**.

FIG. 3C further shows cords **3** and the side pressure on the chord **4** applied by first horizontal coupling element **320** of horizontal coupling element **300**. This may limit the employment of horizontal coupling elements below the leaflet (on the ventricular aspect of the leaflets), where the chordae are attached.

Reference is now made to **FIGS. 4A-E**, which schematically show a two-sided single spiral vertical coupling element **200** (similar to the coupling element shown in **FIG. 2**), a two-sided double spirals vertical coupling element **400**, a two-sided triple spirals vertical coupling element **400'**, and a two-sided quadruple spirals vertical coupling element **400''**, according to some embodiments. During delivery, coupling element **400** is a double stranded wire **410**, which folds into a first double spirals vertical coupling element **420** and subsequently, after penetrating the surfaces to be attached, such as, but not limited to, the supra mitral device and the posterior leaflet of the mitral valve, here illustrated as surfaces **450** and **452**, into a second double spirals vertical coupling element **430**, such that first double spirals vertical coupling element **420** and second double spirals vertical coupling element **430** are positioned on opposite sides of surfaces **450** and **452**, as essentially described herein. According to some embodiments, spirals vertical coupling elements can be doubled, tripled, quadrupled (or more), as the technology enables. This will increase the contact area of the spirals with the leaflet.

FIG. 4B, top, demonstrates, according to some embodiments, the respective contact surfaces of vertical coupling elements **200**, **400** and **400'** with the leaflet.

As further demonstrated in **FIG. 4B**, according to some embodiments, vertical coupling elements may be advantageous over horizontal coupling elements on the ventricular aspect of the mitral leaflets, as they do not apply side pressure on the chordae (**FIG. 3C**).

FIGS. 4C-E, demonstrate, according to some embodiments, a respective view (**FIG. 4C**), an assembled and partially assembled view (**FIG. 4D**) and a top isometric view (**FIG. 4E**) of a two-sided quadruple coiled vertical coupling element **400**".

Reference is now made to **FIG. 5**, which schematically shows a combined
5 coupling element **500**, including a first double vertical spiral **520** and a second
horizontal spiral **530**; according to some embodiments. During delivery, coupling
element **500** is a double stranded wire **510**, which folds into first a double vertical spiral
coupling element **520** and subsequently, after penetrating the surfaces to be attached,
such as, but not limited to, the supra mitral device and the posterior leaflet of the mitral
10 valve, here illustrated as surfaces **550** and **552**, into second horizontal spiral coupling
element **530**, such that first double vertical spiral coupling element **520** and second
horizontal spiral coupling element **530** are positioned on opposite sides of surfaces **550**
and **552**, as essentially described herein. The vertical spiral coupling element is
positioned on the ventricular aspect of the leaflet; the horizontal coupling element is
15 positioned on the atrial aspect of the supra mitral device.

Reference is now made to **FIG. 6**, which schematically illustrates a mitral valve
600 having a supra mitral device **610** attached to its posterior leaflet **650** by a plurality
of coupling elements **620/221**; according to some embodiments. Supra mitral device
610 may be similar to supra mitral device **100** of **FIG. 1A** and **FIG. 1B** having an
20 essentially annular D-shape and an eccentric opening located such that a posterior
section **612** is attached to the posterior leaflet **650** of the mitral valve along its outermost
and innermost margins (two lines of coupling elements: outer line of coupling elements
620 and inner line of coupling elements **621**), and anterior section **614** of supra mitral
device **600** is attached to the anterior leaflet **652**, along its outermost margin only (one
25 line of coupling elements), the aortic-mitral continuity area (shown and marked in **FIG.**
1), thereby preventing or reduce grade of mitral regurgitation.

The exact position of supra mitral device **610** ensures that posterior leaflet **650**
is in its normal position during systole. At this position, the untorn chordae **660** of
posterior leaflet **650** take all the load of the left ventricular systolic pressure (above 100
30 mmHg), which is just what they are used to doing. The supra mitral device, above the
leaflet and bonded to it, is not taking any load at all by itself. At diastole, there is very
little downward driving pressure, left arterial pressure only, pushing posterior section

612 of supra mitral device 600 toward the left ventricle. That is, supra mitral device 610 is positioned in a plane ensuring minimal forces thereon and consequently assuring successful adherence of supra mitral device 610 to posterior leaflet 650 with the coupling elements, after implantation. Thus, a low-load plane is identified and utilized
5 just above the mitral leaflet, which facilitates good coupling and will allow good results in the treatment of regurgitant mitral valve.

According to some embodiments, a part of or the whole supra mitral device 610 is made of a pliable material, adapted to stiffen later after implantation has occurred. This advantageously enables supra mitral device 610 to adopt the anatomical shape of
10 posterior leaflet 650, thereby preventing posterior leaflet 650 from striking against supra mitral device 610 during the dynamics of the cardiac cycle.

According to some embodiments, supra mitral device 610 is configured to attach supra mitrally, i.e. on the aspect of the leaflet facing the left atrium. According to some embodiments, supra mitral device 610 is configured to be attached to posterior
15 leaflet 650 from within the left atrium, along its outer and inner margins, thus being coupled to (essentially) the entire posterior mitral leaflet section which faces the left atrium during systole. According to some embodiments, supra mitral device 610 is delivered through a delivery device.

Embodiments for exemplary delivery devices are presented herein but should
20 not be considered limiting.

According to some embodiments, there is further provided herein a device for positioning the supra mitral device and/or deploying the coupling elements, to secure the supra mitral device in place.

Reference is now made to **FIGS. 7A-L**, which schematically illustrate various
25 embodiments of deployment tools for deploying and positioning supra mitral devices on the valve. The deployment tools shown in **FIGS. 7A-L** are “umbrella” type tools. **FIGS. 7B-L** further illustrate attachment tools for providing the coupling elements to attach the supra mitral devices to the valve leaflets. The attachment tools may be “umbrella” type tools or non- umbrella type tools. The attachment tools may be a part
30 of the “umbrella” type deployment tool or may be a non-umbrella separate tool.

According to some embodiments, the “umbrella” type deployment tools have two modes: open mode and close mode. When the supra mitral devices are inside the catheter they are attached to the umbrella folded to its close mode. When the umbrella with the folded device on it emerges from the catheter above the mitral valve, the umbrella opens and the supra mitral device unfolds. The umbrella is configured for holding and adjusting the device in its final position. The umbrella is removed or detached after the supra mitral device is attached to the leaflets with the coupling elements.

FIG. 7A shows a deployment tool in a shape of an umbrella referred herein as a first umbrella deployment tool **700**. First umbrella deployment tool **700** is configured to deploy/position and detach supra mitral device **800** (but may be applied with any other a supra mitral device, for example, but not limited to, supra mitral device **100**, **100'**, **177**, **178**, **10**, **20**, **30**, **40**, **50** and **60** in **FIGS. 1A-G** and **FIGS. 18-22**) on the mitral valve. PML represents the posterior mitral leaflet and AML represents the anterior mitral leaflet. The radius of umbrella deployment tool **700** may be around 2cm plus/minus 0.7 cm (covers the range of diameters of 3-5.4 cm, which will include most patients). The arms of umbrella deployment tool **700** provide positioning and penetration support.

FIG. 7B shows umbrella deployment tool **700** and an attachment tool, also in a shape of an umbrella, referred to herein as a second umbrella attachment tool **702**, which rides first umbrella deployment tool **700**. Second umbrella attachment tool **702** is configured to release the coupling elements. Two first arms of second umbrella attachment tool **702** are illustrated here, not reaching the margin of supra mitral device **800**, and are intended to release the coupling elements such that they penetrate the leaflet, not the annulus. More arms, such as 4-12 for example, 6-8 arms, may be required for a peripheral line of arms (**FIG. 7C**).

A third umbrella attachment tool **704** may then be added, having an inner line of arms, thus forming a triple umbrella structure (**FIG. 7D, 7E**). The arms of third umbrella attachment tool **704** are directed to an inner rim of supra mitral device **800** on the posterior mitral leaflet only (**FIG 7E**).

FIG. 7E demonstrates a blow-up of two of the coupling elements penetration sites marked in circles (in **FIG. 7D**). In the close-up views, it can be seen that the arms of the umbrellas are thin tubes, through which penetrating wires **705** are inserted to be replaced by coupling elements **706** connecting supra mitral device **800** to leaflet **900** (**FIG. 7F**).

Once the peripheral coupling elements (such as coupling elements **706**) are fully released by second umbrella attachment tool **702**, the inner rim coupling elements are pushed in position by the arms of the third umbrella attachment tool **704** (**FIG. 7G**).

Once outer and inner rim coupling elements (such as coupling elements **706**) are in place, second and third umbrella attachment tools (**702** and **704**, respectively) are released (**FIG. 7H**). The chords **950** are illustrated, and one can note they are essentially parallel to coupling elements **706**. In the last step (**FIG. 7I**), supra mitral device **800** is detached from first umbrella deployment tool **700**, anchored in place by coupling elements **706**. First umbrella deployment tool **700** is then removed.

The three umbrellas are removed, supra mitral device **800** is in place, safely coupled to the mitral valve by coupling elements **706** (**FIG. 7J**). It can be seen that the anterior leaflet's movement is not jeopardized while the posterior leaflet's movement is minimized to nullified/abolished.

Reference is now made to **FIG. 7K I-III**, each schematically illustrating two separate umbrellas: first umbrella deployment tool **700** is configured to deploy, unfold and position supra mitral device **800** in place and second umbrella attachment tool **707**, **708** and **709** respectively, is a separate tool (separate from first umbrella deployment tool **700**), which has the same longitudinal axis as first umbrella deployment tool **700** and is configured for attaching supra mitral device **800** to the valve leaflet by introducing coupling elements through its arms. Each of the first and second umbrellas may be adjusted separately. The first and second umbrellas may be introduced through left Catheterization retrograde through the Aorta or Apical.

In second umbrella attachment tool **707** (**FIG. 7K I**) each arm has one or more preinserted coupling element **721**. Second umbrella attachment tool **707** has (or is associated with) a switch **720** for controlling and selecting which arm to operate.

In second umbrella attachment tool **708 (FIG. 7K II)** coupling elements **723** are directed one by one to each arm. Second umbrella attachment tool **708** has (or is associated with) a switch **720** for controlling and selecting which arm to operate.

In second umbrella attachment tool **709 (FIG. 7K III)** coupling elements **723** are directed by a coupling cartridge **724** one by one to each arm. Second umbrella attachment tool **709** has (or is associated with) a switch **720** for controlling and selecting which arm to operate. Switch **720** is further configured to direct coupling cartridge **724** to a different umbrella arm each time. Coupling cartridge **724** may include a plurality of separated coupling elements (such as coupling elements **723**) or a wire from which coupling elements (such as coupling elements **723**) are produced (e.g., cut).

Reference is now made to **FIG. 7K IV-VI**, each schematically illustrating a composite triple umbrella including: first umbrella deployment tool **700** is configured to deploy, unfold and position supra mitral device **800** in place, a second umbrella attachment tool **710, 711 and 712** respectively, configured for attaching supra mitral device **800** to the valve leaflet by introducing coupling elements through its arms (to the posterior and anterior leaflets along their outer margins), and a third umbrella attachment tool **713, 714 and 715** respectively, configured for attaching supra mitral device **800** to the valve leaflet by introducing coupling elements through its arms (to the posterior leaflet along its inner margins). The triple umbrellas may be introduced through left Catheterization retrograde through the Aorta or Apical.

In second umbrella attachment tool **710** and third umbrella attachment tool **713 (FIG. 7K IV)** each arm has one or more preinserted coupling element **723** and has (or is associated with) a switch **720** for controlling and selecting which arm to operate.

In second umbrella attachment tool **711** and third umbrella attachment tool **714 (FIG. 7K V)** coupling elements **723** are directed one by one to each arm. Second umbrella attachment tool **711** and third umbrella attachment tool **714** have (or are associated with) a switch **720** for controlling and selecting which arm to operate.

In second umbrella attachment tool **712** and third umbrella attachment tool **715 (FIG. 7K VI)** coupling elements **723** are directed by coupling cartridge **724** one by one to each arm. Second umbrella attachment tool **712** and third umbrella attachment tool **715** have (or are associated with) switch **720** for controlling and selecting which arm to

operate. Switch **720** is further configured to direct coupling cartridge **724** to a different umbrella arm each time. Coupling cartridge **724** may include a plurality of separated coupling elements (such as coupling elements **723**) or a wire from which coupling elements (such as coupling elements **723**) are produced (e.g., cut).

5 Reference is now made to **FIG. 7L I-IV**, each schematically illustrates a first umbrella deployment tool **700** configured to deploy, unfold and position supra mitral device **800** in place, and single arm attachment tools **716**, **717**, **718** and **719** respectively, configured for attaching supra mitral device **800** to the valve leaflet by introducing coupling elements through its arm.

10 As shown in **FIG. 7L I-II** both first umbrella deployment tool **700** and respective single arm attachment tools **716** and **717** are inserted on the same axis by left sided retrograde procedure through the aorta or apically. Single arm attachment tool **716** (**FIG. 7L I**) is configured to deploy a single coupling element at a time (one by one) and thus attach supra mitral device **800** to the mitral leaflets all around. Single arm
15 attachment tool **717** (**FIG. 7L II**) has a cartridge of multiple coupling elements for one by one insertion and is thus configured to attach supra mitral device **800** to the mitral leaflets all around.

 As shown in **FIG. 7L III-IV** first umbrella deployment tool **700** is inserted by left sided retrograde procedure through the aorta or apically, while respective single
20 arm attachment tools **718** and **719** are introduced through right catheterization. Single arm attachment tool **718** (**FIG. 7L III**) is configured to deploy a single coupling element at a time (one by one) and thus attach supra mitral device **800** to the mitral leaflets all around. Single arm attachment tool **719** (**FIG. 7L IV**) has a cartridge of multiple coupling elements for one by one insertion and is thus configured to attach
25 supra mitral device **800** to the mitral leaflets all around.

 It is noted that, in accordance with some embodiments, the deployment/attachment tools presented in **FIGS. 7A-L** may be used for deploying any one of the supra mitral devices disclosed herein, for example, but not limited to, supra mitral device **100**, **100'**, **177**, **178**, **10**, **20**, **30**, **40**, **50** and **60** in **FIGS. 1A-G** and **FIGS.**
30 **18-22**. In accordance with additional/alternative embodiments, the deployment tools presented in **FIGS. 7A-L** may be used for deploying any supra mitral devices.

It is also noted that, in accordance with some embodiments, the any one of the coupling/coupling elements presented herein (for example, but not limited to, in **FIGS. 2-6**) may be used with any one of the deployment tools presented herein (for example, but not limited to, in **FIGS. 7 A-L**) for deploying any one of the supra mitral devices disclosed herein, for example but not limited to supra mitral device **100, 100', 177, 178, 10, 20, 30, 40, 50** and **60** in **FIGS. 1A-G** and **FIGS. 18-22**. In accordance with additional/alternative embodiments, the deployment tools presented in **FIGS. 7A-L** may be used for deploying any supra mitral devices.

10 **Transcatheter Mitral Valve Repair (TMVRr) for Functional Mitral Regurgitation (FMR):**

Reference is now made to **FIG. 8- Fig. 15**, which show the problems related to FMR and to the existing attempts to solve these problems. **FIG. 8** schematically illustrates the mitral valve region with normal LV (left) and after posterior wall myocardial infarction (MI) (right) in diastole. It can be seen that after posterior wall MI with scarring of the posterior wall, the mitral valve seems rather normal on diastole.

FIG. 9 schematically illustrates the mitral valve region with normal LV contraction with normal MV coaptation (left) – good coaptation of PML with the AML is achieved; and

20 Abnormal LV contraction after posterior wall MI (right) in systole. It can be seen that the “normal appearing mitral valve” is not effective: The failure of the posterior infarcted LV wall to contract, and even more, bellow in the opposite direction, causes a pull-down effect on the posterior leaflet (thin arrow), generating MR. This type of MR is called functional MR (FMR).

25 The following depict the respective parts in the valve region:

- 1- Posterior mitral leaflet;
- 2- Chordae;
- 3- Anterior mitral leaflet;
- 4- Chordae;

5- Papillary muscles; and

6- Aortic valve

AMC – Aortic-mitral continuity

FIG. 10 schematically illustrates papillary muscle displacement and posterior leaflet tethering post MI (right) in comparison to normal papillary muscle (left). Tethering may involve the anterior leaflet, to a lesser extent (R. A. Levine, E. Schwammenthal: *Circulation*. 2005;112:745-758).

FIG. 11 schematically illustrates a view of the mitral valve from the LA in systole in heart post posterior MI (right), in comparison to normal mitral valve with normal coaptation (left). In heart post posterior MI (right) one can notice, pull-down (tethering) of the posterior leaflet mostly, causes mal-coaptation and MR. Posterior wall MI with abnormal contraction/movement of the posterior wall and papillary muscles, causes pull-down on segments of the posterior leaflet. This is most evident on P2 and adjacent parts. In a normal mitral valve (left) one can notice good coaptation with no MR.

FIG. 12 schematically illustrates an undersized ring repair according to the prior art (Steven Bolling). Recurrent mitral regurgitation is demonstrated after annuloplasty for functional ischemic mitral regurgitation as evident, for example by the following publication: “During the first 6 months after repair, the proportion of patients with 0 or 1+ mitral regurgitation decreased from 71% to 41%, whereas the proportion with 3+ or 4+ regurgitation increased from 13% to 28%.” (McGee EC, Gillinov AM, Blackstone EH, Rajeswaran J, Cohen G, Najam F, Shiota T, Sabik JF, Lytle BW, McCarthy PM, Cosgrove DM J Thorac Cardiovasc Surg 2004; 128: 916). Namely, after a seemingly successful FMR surgical repair with under-sized ring, in follow-ups, the MR returned/increased significantly is just few months. This is as the LV remodeling continues, the LV dilates more and more and the down-tethering of the mitral leaflet gets even worse (“LV remodeling is a moving target”). This further reduces mitral leaflet coaptation, and MR increases. This report shows that under-sized ring approach has bad intermediate and long-term results.

FIG. 13 schematically illustrates the mechanism of recurrent ischemic mitral regurgitation after annuloplasty. The LV remodeling is continued as a moving target

(Judy Hung et al. *Circulation*. 2004;110:II-85). “Undersized annuloplasty corrects annular dilatation but worsens leaflet tethering and flattening”) J. Daniel Robb et al.: *Eur J Cardiothorac Surg*. 2011 Dec; 40(6):1501 (Experimental)) “Posterior leaflet augmentation and less-extreme annular undersizing would relieve tethering and increase leaflet curvature”.

FIG. 14 schematically illustrates an intra-operative picture of prior art posterior leaflet augmentation for FMR in human patients (S. Mitsuyama et al.: *Mitral Valve Repair by Posterior Leaflet Augmentation for Ischemic Mitral regurgitation*. In: *AATS Mitral Conclave; Breakout Session 9: Surgery for Ischemic Mitral Regurgitation*, Thursday, April 27, 2017). The mean implanted annuloplasty ring size was 32.4 ± 1.5 mm. All that is seen as the posterior leaflet (*) is the pericardial augmentation patch. What seems to be the posterior leaflet in this picture, marked with a star, is not a mitral leaflet at all: it is the pericard used for posterior leaflet augmentation. It coapts to the anterior leaflet (the top of the picture), which is a true leaflet.

FIG. 15 illustrates a schematic view of the mitral valve from the LA in systole FMR. As demonstrated (in the region depicted by the symbol “*”), the tethered down PML in FMR generates mal-coaptation of the anterior and posterior leaflets. Areas of the PML are tethered down in FMR, while P2 and p3 are not affected (or minimally affected). An under-sized ring has inherent drawbacks, it increases posterior leaflet tethering and MR often returns (“Continued LV Remodeling as a Moving Target” Judy Hung et al. *Circulation*. 2004;110:II-85).

There is thus provided herein, in accordance with some embodiments, a supra mitral device and method for mitral valve repair in a subject suffering from FMA. The device includes a supra mitral device having essentially annular D-shape with an eccentric opening, such that a posterior section of the supra mitral device is wider than an anterior section of the supra mitral device, the posterior section of the supra mitral device configured for coverage and attachment to essentially all of the posterior leaflet of the mitral valve and (significantly) overlap at least a portion of the anterior leaflet of the mitral valve, thereby preventing and/or reducing mitral regurgitation, wherein the section of the posterior section of the supra mitral device which is configured to cover the posterior leaflet is made of a pliable material, adapted to stiffen after implantation of the device and wherein the part of the posterior section of the supra mitral device,

which is configured to overlap at least a portion of the anterior leaflet is made of a softer material than the rest of the supra mitral device.

According to some embodiments, the supra mitral device is configured for coupling to the circumference of the mitral valve, and additionally for coupling to P1
5 and P3 leaflets. Further LV remodeling causes stronger tethering, which then effects P1 and P3 more and more, pulling the augmented posterior leaflet down, thus preserving its coaptation with the anterior leaflet.

Advantageously, this supra mitral device, according to some embodiments, does not involve annuloplasty and thus avoids an increase of the posterior leaflet tethering.
10 Utilizing the posterior leaflet augmentation supra mitral device, according to some embodiments, the problem of continued LV remodeling and increased tethering, which is more prominent in the posterior leaflet is prevented or at least mitigated. According to some embodiments, the supra mitral device is coupled to the mitral leaflet itself along its perimeter mostly, with extra pins on P1 and P3, the less tethered segments of the
15 posterior mitral leaflet. **FIG. 16** schematically illustrates the supra mitral device and the coupling thereof (marked by + and *), according to some embodiments. The coupling of the supra mitral device takes advantage of the fact that the tethering is not equally spread throughout the leaflets. The figure on the left shows a heart post posterior MI. As can be seen, pull-down (tethering) of the posterior leaflet, causes mal-coaptation
20 and MR. The tethering of the PML leaves areas can be seen with no to minimal pull-down in P1 and P3, and the peripheral rim of P2. The tethering is maximal at the posterior side, much less in P1 and P3, leaving landing site for the supra mitral device: the “+” signs represent the coupling of the supra mitral device to the peripheral rim of the valve and the stars present coupling on P1 and P3 inner margin, which adjust the
25 height of the augmentation segment via the AML. **FIG. 17** and **FIG. 18** schematically illustrate the supra mitral device used in FMR, according to some embodiments. The supra mitral device **10** may have a shape similar to the shape of device **100** i.e., an essentially annular, D shape and an eccentric opening, the opening located such that a posterior (marked as “P”) section of device **100** is wider than an anterior (marked as
30 “A”) section of device **100**. A difference, compared to device **100**, is that device **10** has a wider posterior part, which overlaps significantly the anterior mitral leaflet. **FIG. 19** schematically illustrates the supra mitral device **10** for FMR and coupling (marked by

“*” and “+” signs) thereof, according to some embodiments. A key principle in coupling the device in FMR, according to some embodiments, are the coupling to P1 and P3 whose pull-down is minimal, and thus the support to the free anterior margin of the posterior part of the device is enhanced.

5 **FIG. 20** schematically illustrates supra mitral device **20** for FMR and coupling (marked by “*” and “+” signs) thereof, according to some embodiments. According to some embodiments, suspension **25** of the posterior part of supra mitral device **20** overlapping with the AML may be like of a semi-lunar cusp, with the surrounding attachment pins and device shape providing all around support, and the LV pressure
10 compresses the AML against it.

 According to some embodiments, suspension **25** of the device overlapping with the anterior mitral leaflet may be made of a softer (compared to the rest of the device) and atraumatic material.

FIG. 21 schematically illustrates two types of devices, according to some
15 embodiments:

- I- supra mitral device **10**, wherein the posterior part of the device does not overlap with the anterior leaflet. This type of device can be used, for example, for myxomatous mitral and chordae tear.
- II- supra mitral device **20** having a suspension **25** and thus providing an overlap with
20 the anterior leaflet. This type of device can be used in FMR.

FIGS. 22 I-IV schematically illustrate different variations of supra mitral devices for use in FMR, namely devices **30**, **40**, **50** and **60**, respectively, according to some embodiments. The supra mitral devices **30**, **40**, **50** and **60**, have a shape similar to the shape of device **100** i.e., an essentially annular, D shape and an eccentric opening, the
25 opening located such that a posterior (marked as “P”) section of device **100** is wider than an anterior (marked as “A”) section of device **100**. A difference in supra mitral devices **30**, **40**, **50** and **60** compared to device **100**, is that supra mitral devices **30**, **40**, **50** and **60** have a wider posterior part, which overlaps significantly the anterior mitral leaflet.

FIGS. 22 I schematically shows a supra mitral device **30**, having essentially a narrow anterior part **32**, a posterior part **36** having an extension **34** between posterior part **36** and the opening of device **30**; extension **34** is configured to cover (overlap with) the anterior mitral leaflet. Extension **34** may integrally be formed with posterior part **36**.
5 Extension **34** may integrally be contiguous with posterior part **36**. Extension **34** may be connected to posterior part **36**.

FIGS. 22 II schematically shows a supra mitral device **40**, having essentially a narrow anterior part **42**, a posterior part **46** having an extension **44** between posterior part **46** and the opening of device **40**; extension **44** is configured to cover (overlap with) the anterior mitral leaflet. Extension **44** may integrally be formed with posterior part **46**.
10 Extension **44** may integrally be contiguous with posterior part **46**. Extension **44** may be connected to posterior part **46**. Device **40** further comprises an enforcement member **48** extending along an inner edge of the opening thereof.

FIGS. 22 III schematically shows a supra mitral device **50**, having essentially a narrow anterior part **52**, a posterior part **56** having an extension **54** between posterior part **56** and the opening of device **30**; extension **54** is configured to cover (overlap with) the anterior mitral leaflet. Extension **54** may integrally be formed with posterior part **56**. Extension **54** may integrally be contiguous with posterior part **56**. Extension **54** may be connected to posterior part **56**. Supra mitral device **50** has a varying stiffness (stiffness gradient) between an outer and an inner perimeter thereof. For example, the stiffness increases along an axis extending from an inner to an outer perimeter of device **50**.
15
20

FIGS. 22 IV schematically shows a supra mitral device **60**, having essentially a narrow anterior part **62**, a posterior part **66** having an extension **64** between posterior part **66** and the opening of device **60**; extension **64** is configured to cover (overlap with) the anterior mitral leaflet. Extension **64** may integrally be formed with posterior part **66**. Extension **64** may integrally be contiguous with posterior part **66**. Extension **64** may be connected to posterior part **66**. Device **60** further comprises an enforcement member **68** extending along an inner edge of the opening thereof. Supra mitral device **60** has a varying stiffness (stiffness gradient) between an outer and an inner perimeter thereof.
25
30 For example, the stiffness increases along an axis extending from an inner to an outer perimeter of device **60**.

The terminology used herein is for the purpose of describing particular embodiments only and is not intended to be limiting. As used herein, the singular forms “a”, “an” and “the” are intended to include the plural forms as well, unless the context clearly indicates otherwise. It will be further understood that the terms “comprises” or
5 “comprising,” when used in this specification, specify the presence of stated features, integers, steps, operations, elements, or components, but do not preclude or rule out the presence or addition of one or more other features, integers, steps, operations, elements, components, or groups thereof.

While a number of exemplary aspects and embodiments have been discussed
10 above, those of skill in the art will recognize certain modifications, additions and sub-combinations thereof. It is therefore intended that the following appended claims and claims hereafter introduced be interpreted to include all such modifications, additions and sub-combinations as are within their true spirit and scope.

CLAIMS**What we claim is:**

1. A supra mitral device for mitral/tricuspid valve repair in a subject in need thereof, the device comprising:
 - 5 a main body portion having essentially annular D-shape with an eccentric opening, such that a posterior section of said main body portion is wider than an anterior section of said main body portion, said posterior section of said main body portion configured for coverage and attachment to essentially the whole section of the posterior leaflet of the mitral valve which faces the left atrium on systole, thereby
10 preventing and/or reducing mitral regurgitation, wherein said posterior section of said main body portion is made of a pliable material, adapted to stiffen after implantation of the device.
 2. The device of claim 1, wherein said posterior section of said main body portion is configured to stay attached/adherent/bonded to said posterior leaflet throughout
15 said cardiac cycle, eventually maintaining/immobilizing said posterior leaflet at an essentially permanently elevated/closed position.
 3. The device of claim 1, wherein said posterior section of said main body portion is attached to said posterior leaflet while assuming a shape of said posterior leaflet.
 4. The device of claim 1, wherein said main body portion is not directly attached to an
20 annulus of said mitral valve.
 5. The device of claim 1, wherein the main body portion further comprises a plurality of through holes for securing said device to said mitral valve leaflet.
 6. The device of claim 1, wherein the pliable material comprises felt and/or, cloth, woven or knitted.
 - 25 7. The device of claim 6, wherein the felt comprises Teflon™, Dacron™, PTFE (Gortex™), or any combination thereof.
 8. The device of claim 1, wherein the main body portion has a stiffness gradient between an outer and an inner perimeter thereof.

9. The device of claim 1, further comprising an enforcement element extending along an inner perimeter of said main body portion.
10. The device of claim 1, further comprising an enforcement element extending along at least a part of an inner perimeter of said main body portion configured to support a particular location of the posterior leaflet where a leakage occurs.
11. The device of claim 1, wherein said posterior section of said main body portion is configured to extend beyond the area of the posterior leaflet and thus to overlap a portion of an anterior mitral leaflet, thereby preventing/reducing mitral regurgitation.
12. The device of claim 1, wherein said main body portion further comprises an extension, contiguous with or attached to said posterior section and configured to extend beyond the area of the posterior leaflet and thus, when implanted, to overlap with a posterior part of an anterior leaflet, thereby preventing/reducing mitral regurgitation.
13. The device of claim 12, wherein the extension is made of a less traumatic material than that of said posterior section.
14. The device of claim 1, configured for trans-catheter implantation.
15. The device of anyone of claims 1-14, wherein the subject suffers from mitral insufficiency.
16. The device of claim 15, wherein the mitral insufficiency comprises fibroelastic deficiency, myxomatous mitral valve, functional mitral regurgitation (FMR), or combinations thereof.
17. A coupling element comprising a wire comprising a memory shape material configured to assume a spiral shape; wherein the spiral comprises a first spiral and a second spiral interconnected by an essentially straight wire; wherein a distal end of the first end forms the innermost loop of the first spiral, and a proximal end of the first end forms the outermost loop of the first spiral; and wherein a distal end of the second end forms the outermost loop of the second spiral and a proximal end of the second end forms the innermost loop of the second spiral.

18. A coupling element comprising a wire comprising a memory shape material configured to assume a spiral shape; wherein the spiral comprises a first spiral and a second spiral interconnected by an essentially straight wire; wherein a distal end of the first end forms the outermost loop of the first spiral, and a proximal end of the first end forms the innermost loop of the first spiral; and wherein a distal end of the second end forms the innermost loop of the second spiral and a proximal end of the second end forms the outermost loop of the second spiral.
19. The coupling element of any of claims 17-18, configured to attach the supra-mitral main body portion of any of claims 1-16 to the leaflets of a mitral valve.
20. The coupling element of claim 17, wherein the first and second spirals are positioned on opposite sides of said main body portion and mitral leaflet, when attached.
21. The coupling element of any of claims 17-20, comprising featherlike enveloping fibers configured to cushion its touch on the tissue, as well as to form a skeleton for clots and tissue formation.
22. A method of Per Cutaneous Mitral Valve Repair or Replacement (PCMVR), the method comprising attaching the device of any one of claims 1-16, supra mitrally, to a posterior leaflet along its outer and inner margins, thus coupling the device to the entire posterior mitral leaflet section that faces the left atrium on systole, and to the anterior leaflet at its outer margins only, thus completing attachment of the main body portion to the circumference of the mitral valve.
23. The method of claim 15, wherein attaching comprises using multiple coupling elements of any one of claims 17-21.
24. The method of any one of claims 22-23, further comprising a later second stage step, if residual mitral regurgitation is deemed unacceptable on follow-up, to exploit the device as a docking system for per-catheter mitral valve replacement.
25. A kit for Per Cutaneous Mitral Valve Repair or Replacement (PCMVR), the kit comprising:
- the device of any one of claims 1-16; and

a plurality of coupling elements configured to attach the main body portion to the leaflet of the mitral valve.

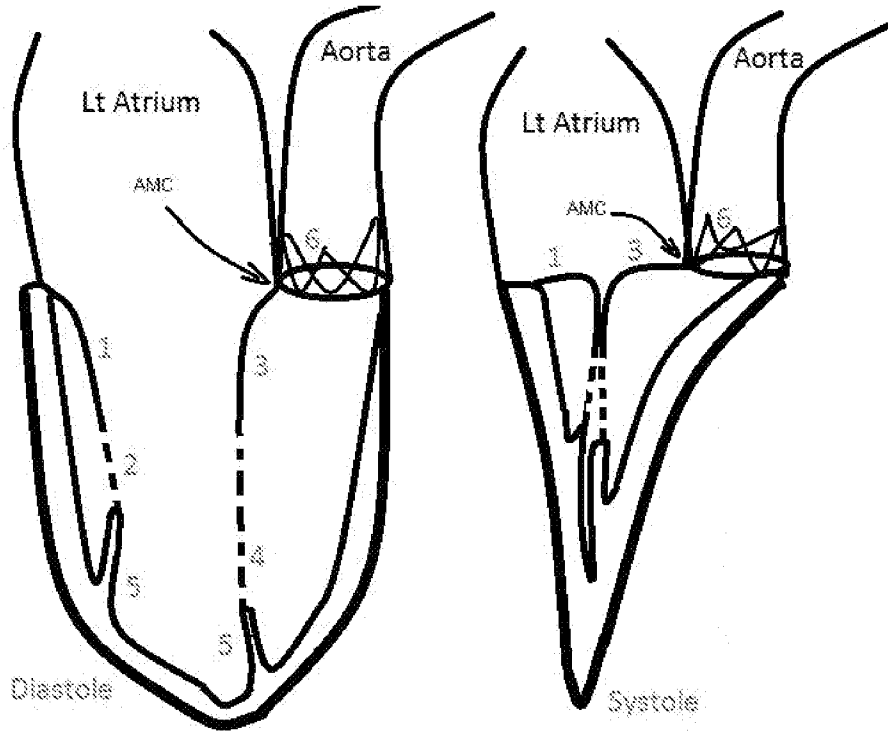

FIG. 1

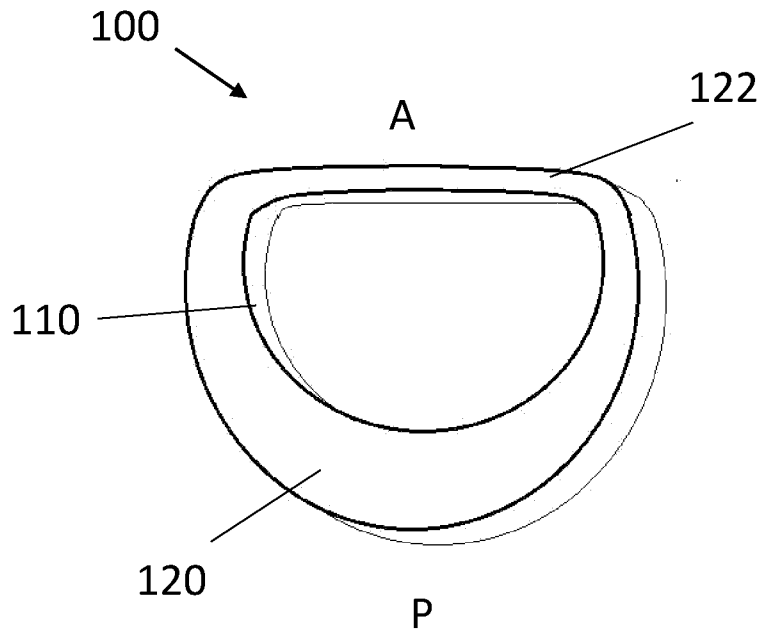

FIG. 1A

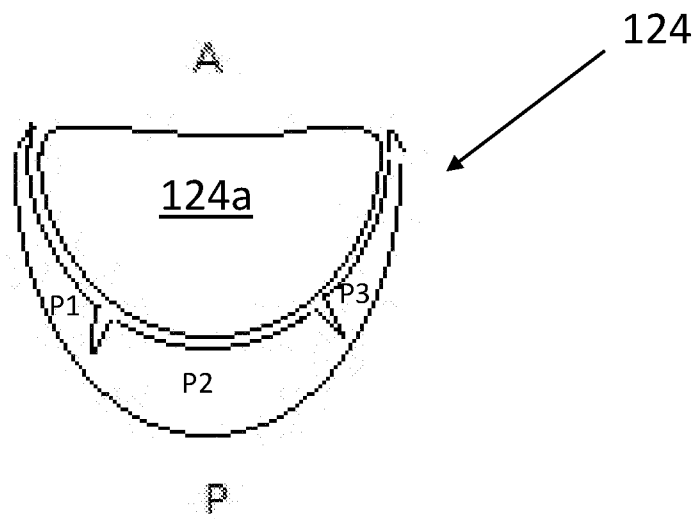

FIG. 1B

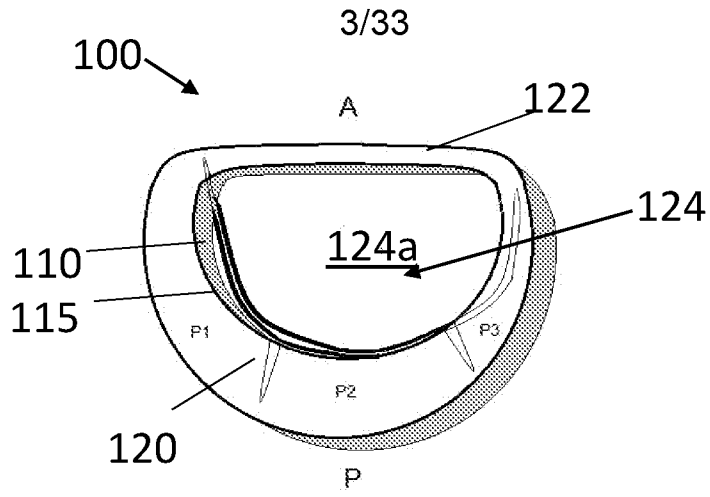

FIG. 1C

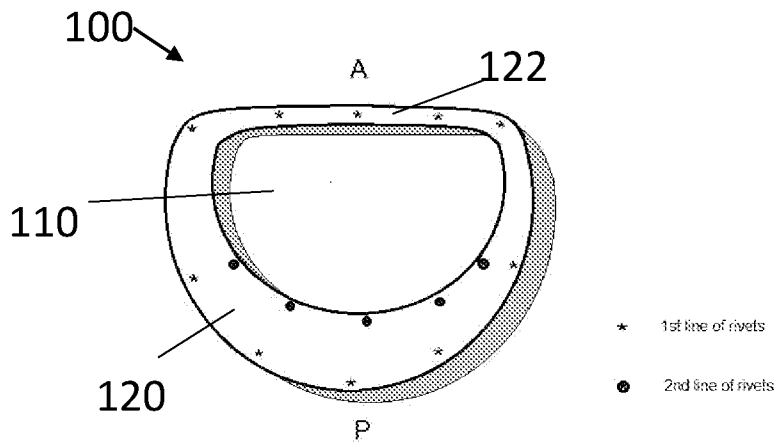

FIG. 1D

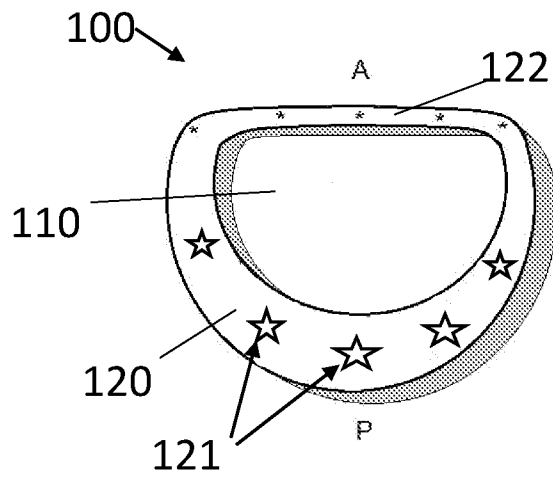

FIG. 1D'

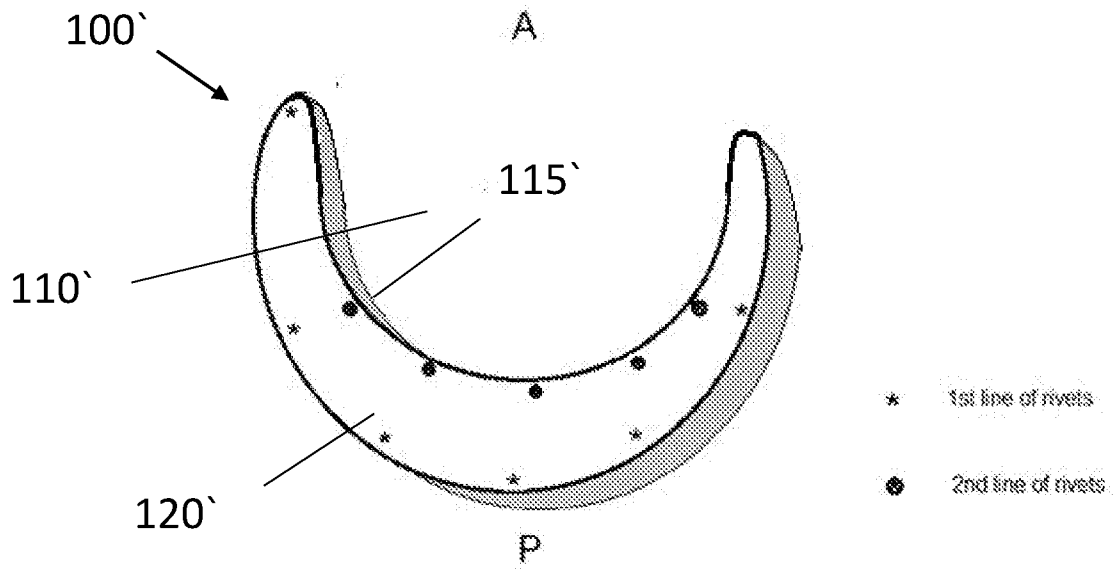

FIG. 1E

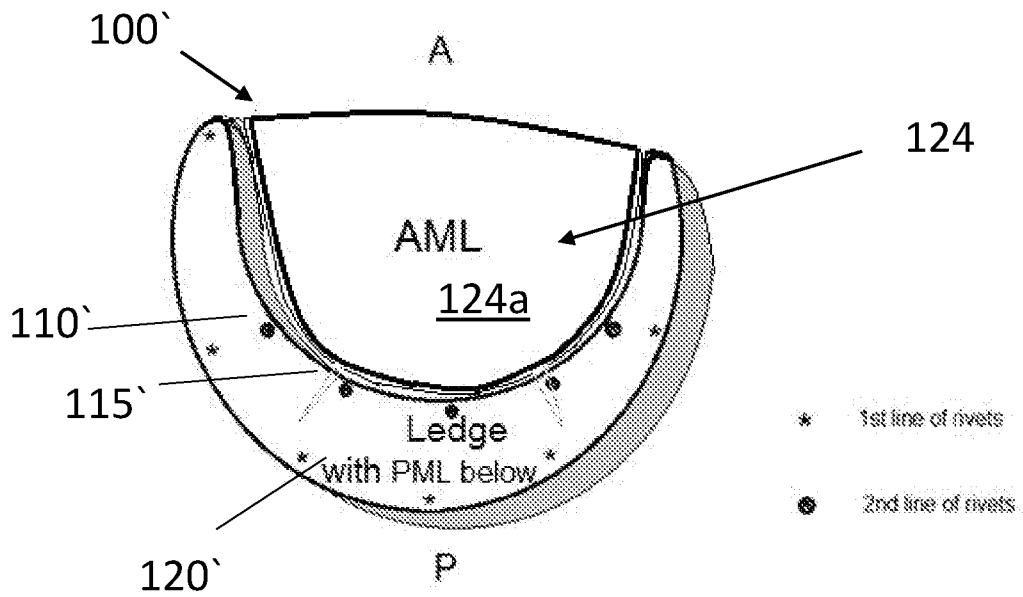

FIG. 1F

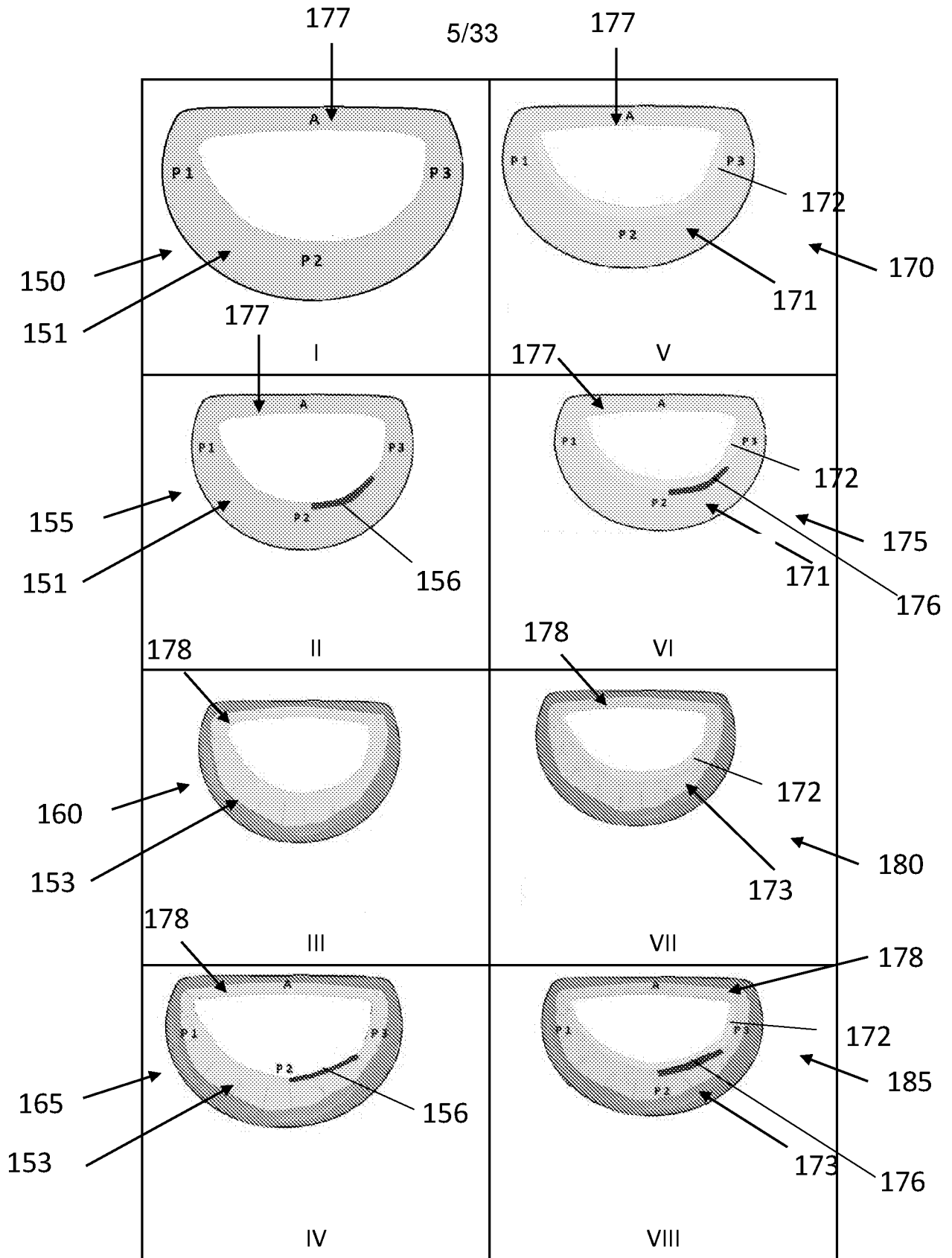

FIG. 1G

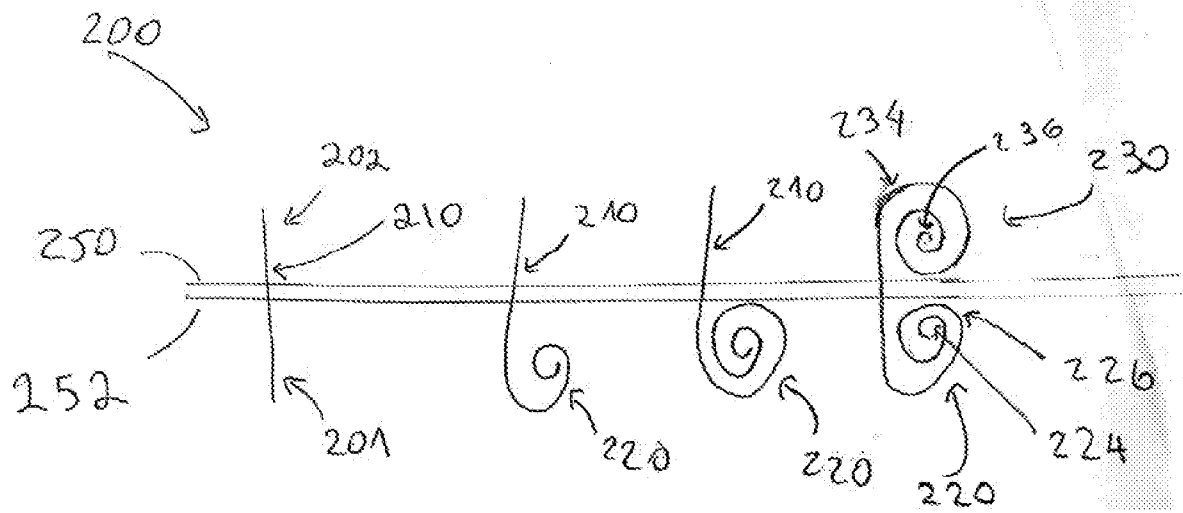

FIG. 2

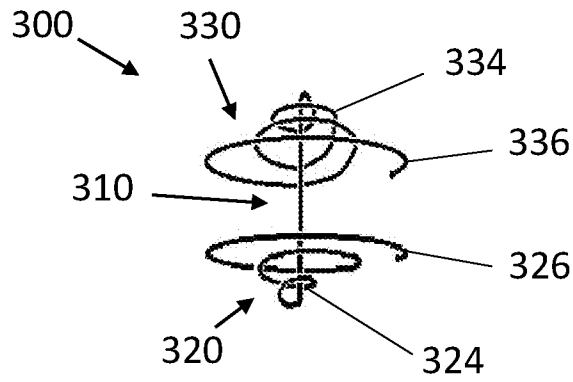

FIG. 3A

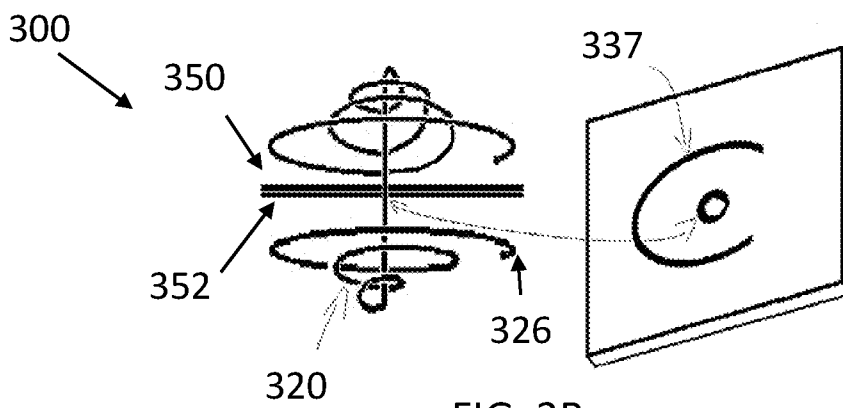

FIG. 3B

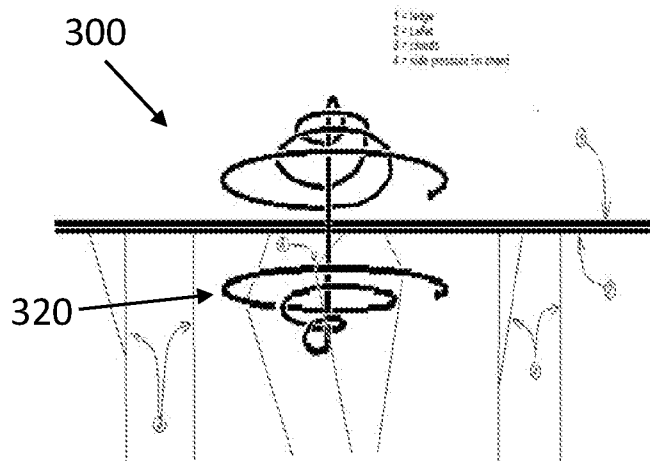

FIG. 3C

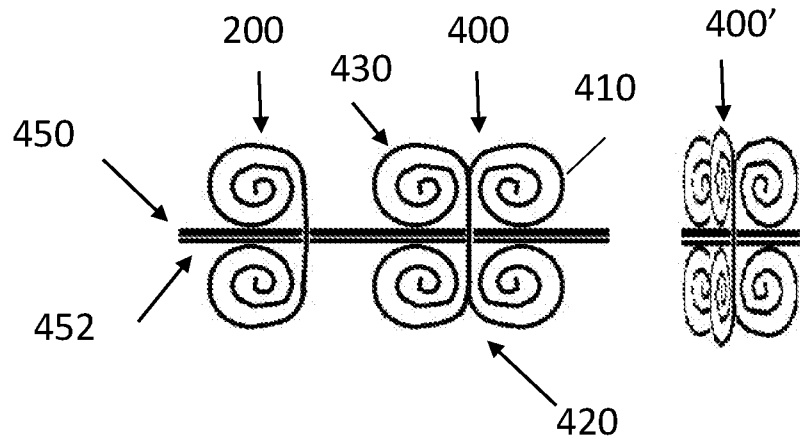

FIG. 4A

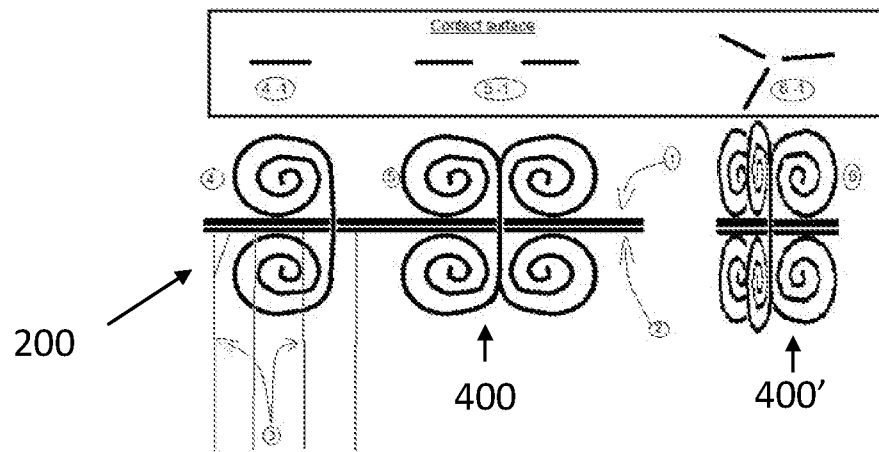

FIG. 4B

9/33

400''

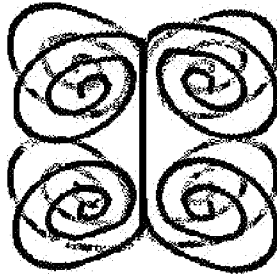

FIG. 4C

400''

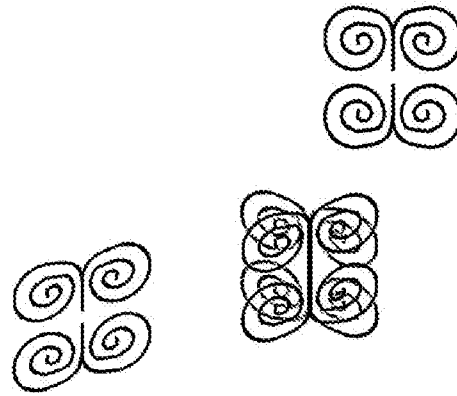

FIG. 4D

400''

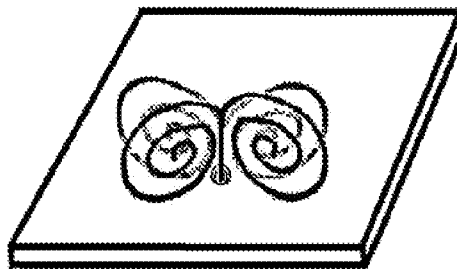

FIG. 4E

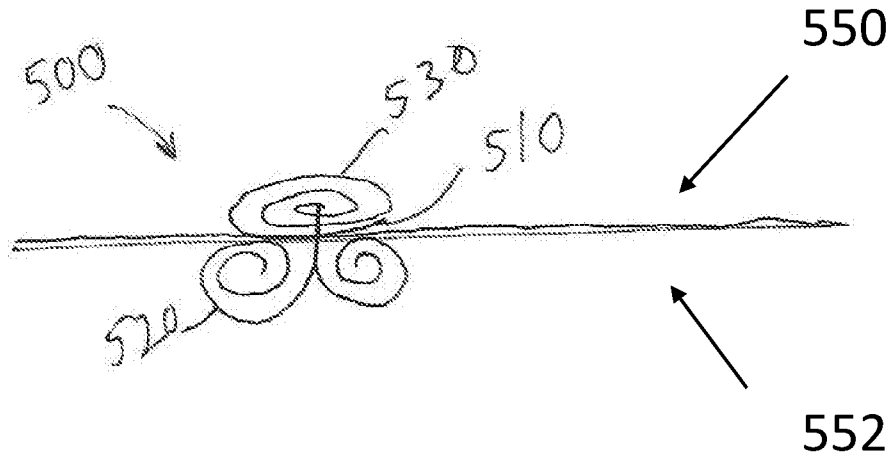

FIG. 5

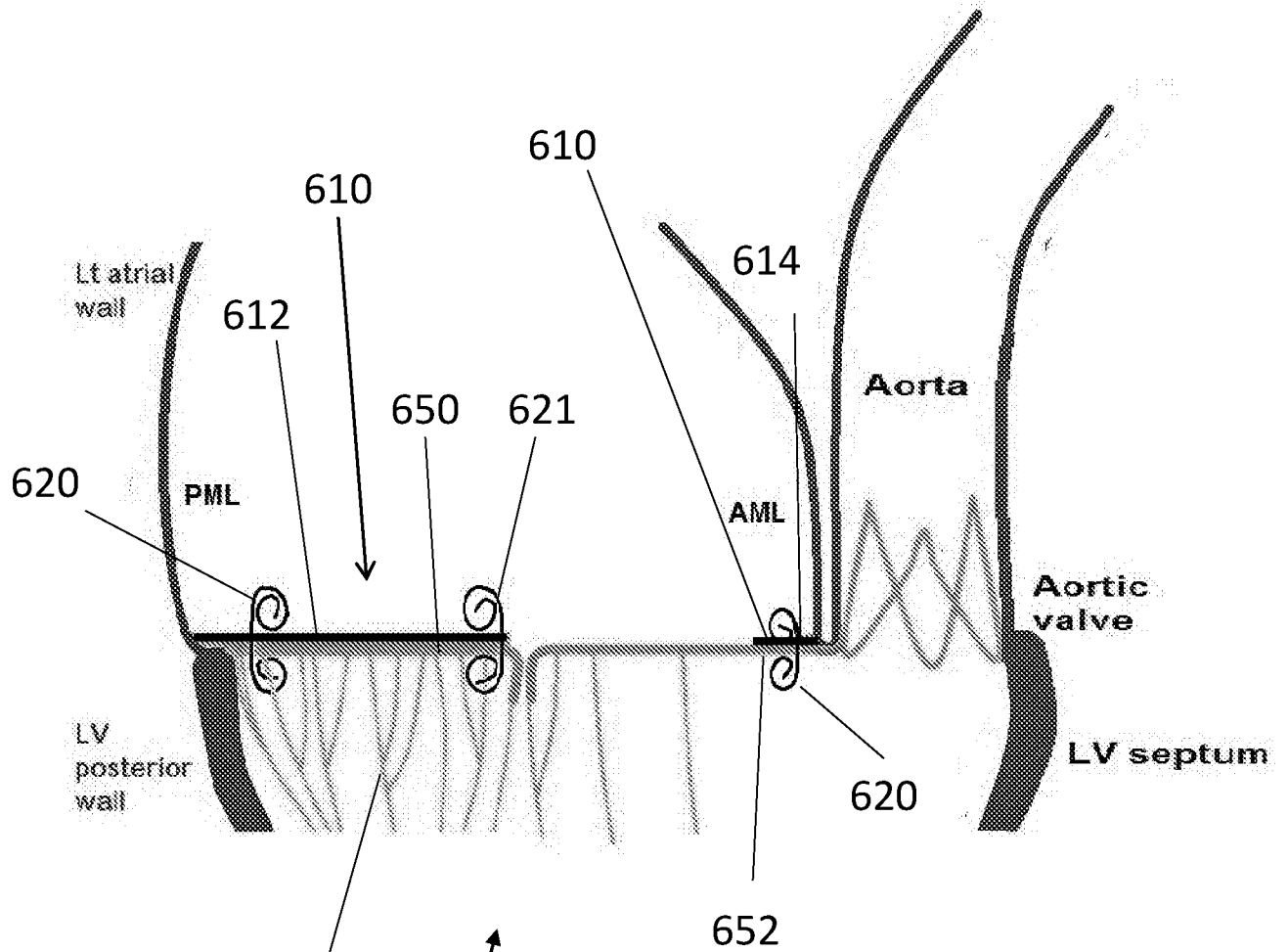

FIG. 6

600

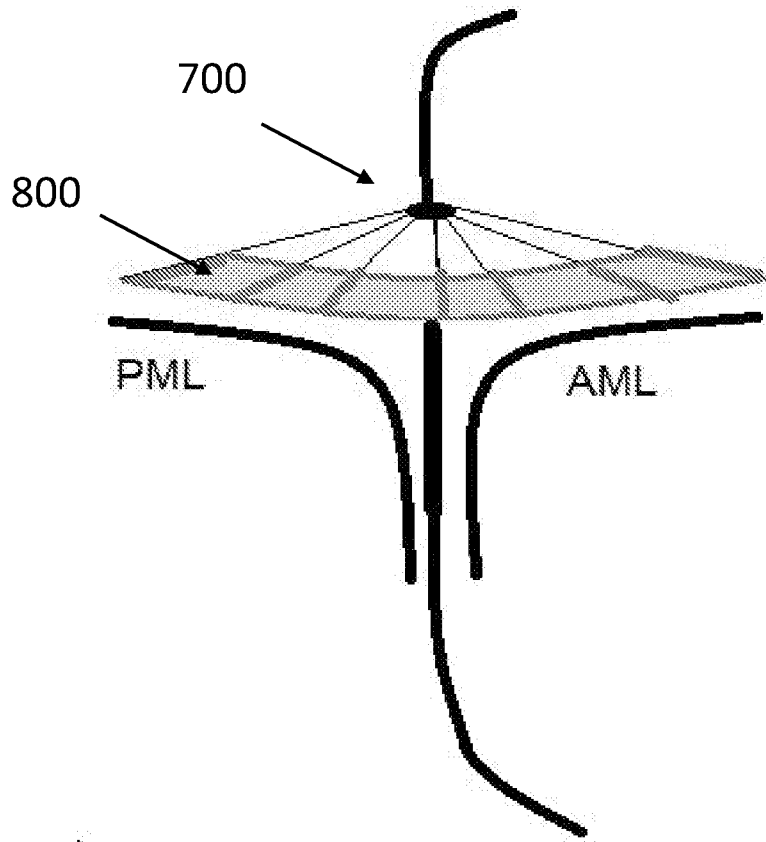

FIG. 7A

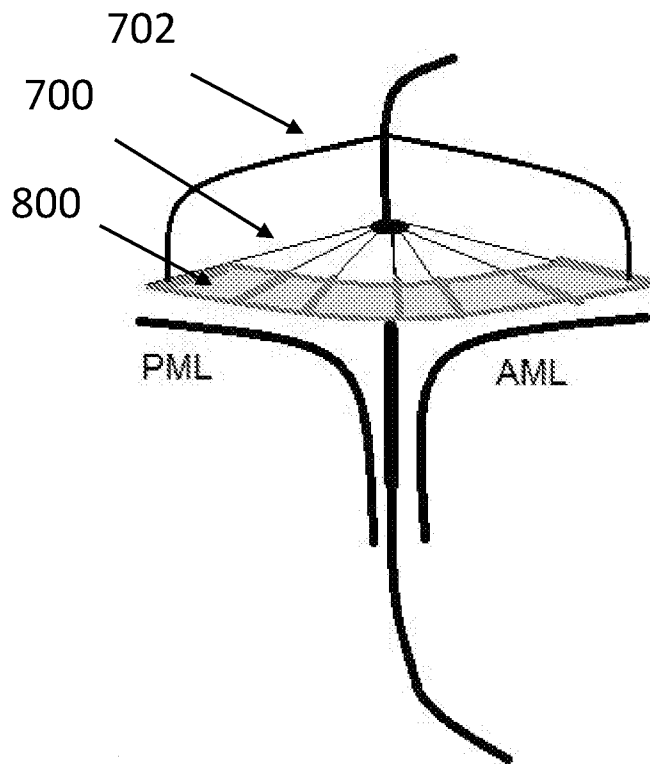

FIG. 7B

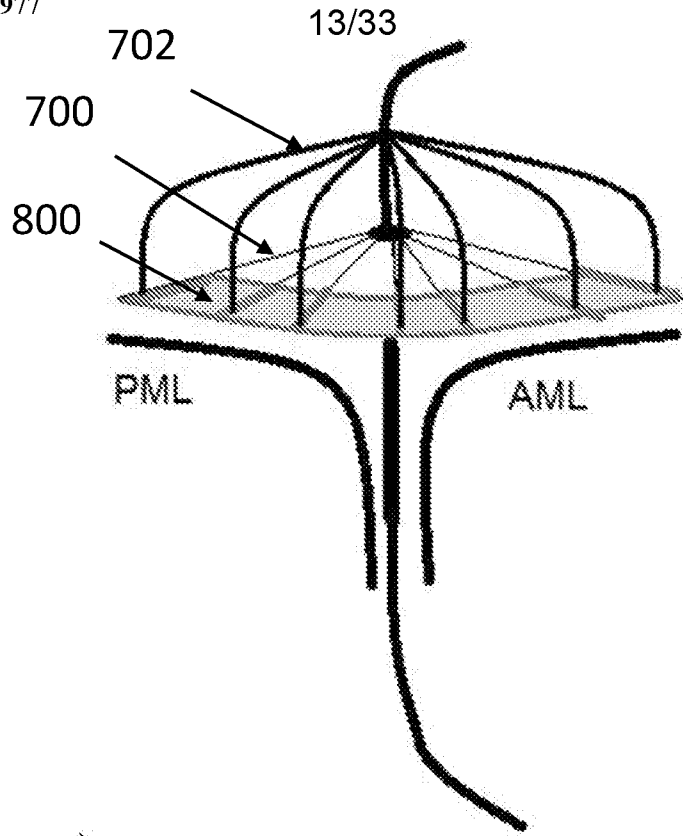

FIG. 7C

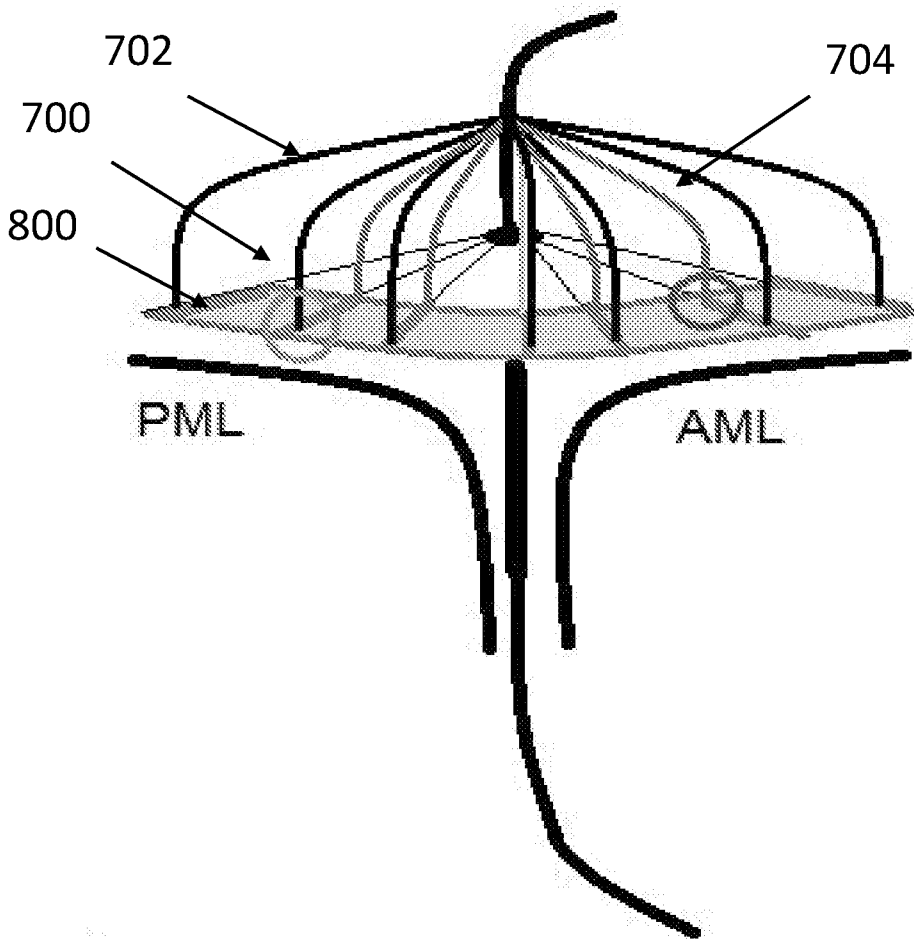

FIG. 7D

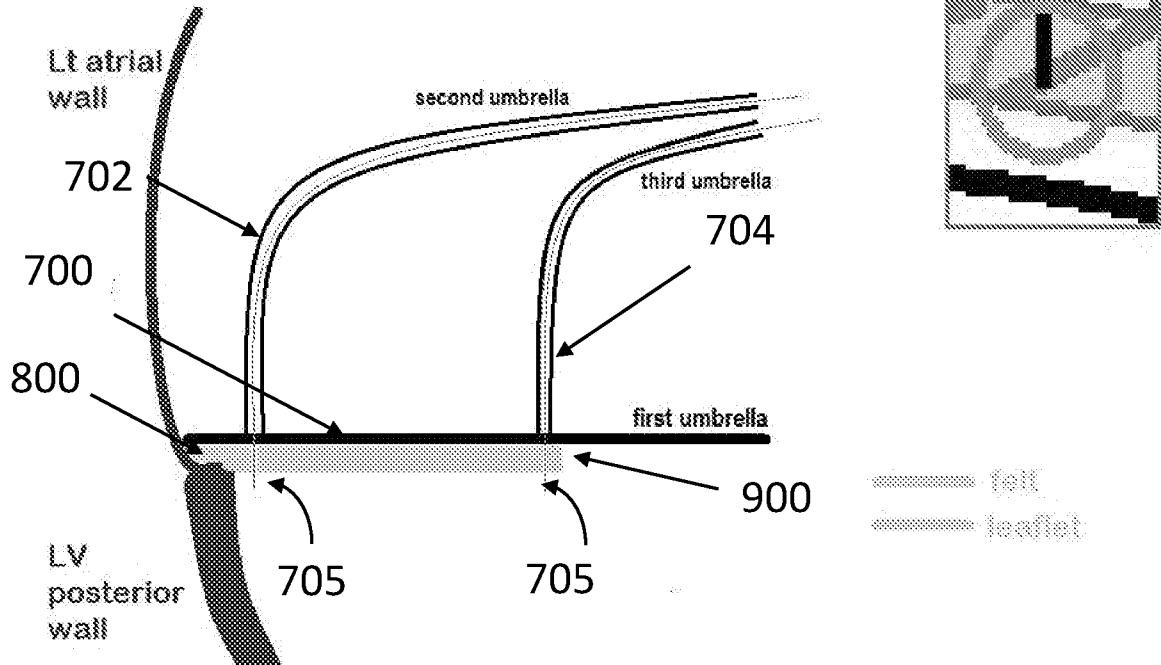

FIG. 7E

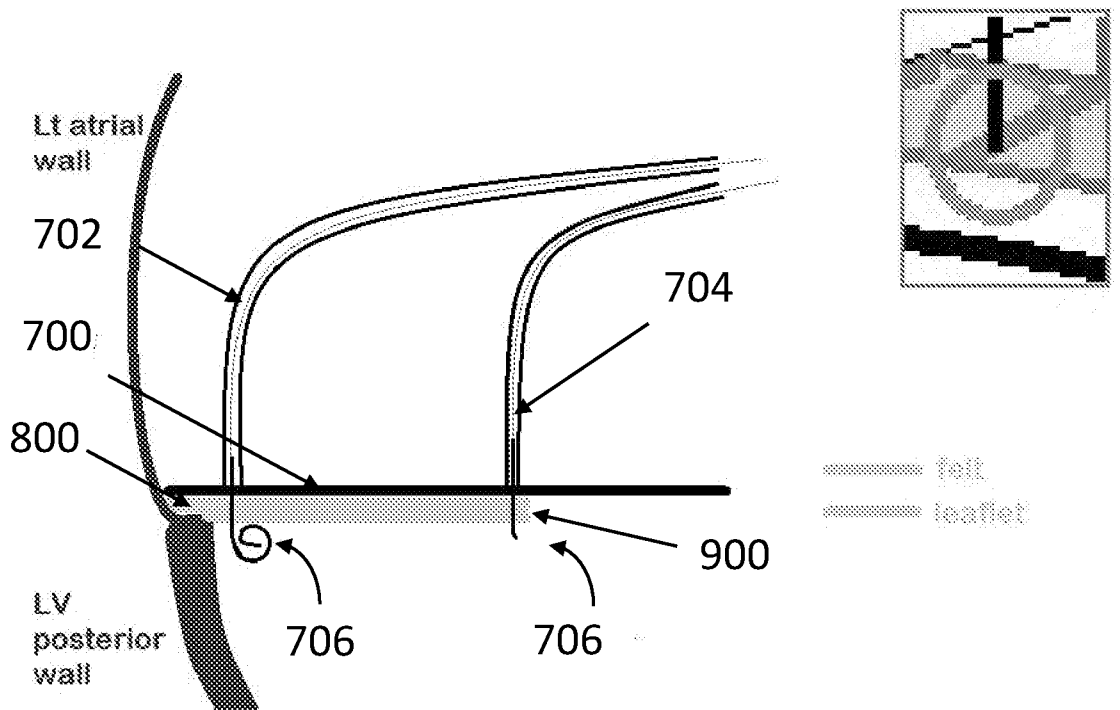
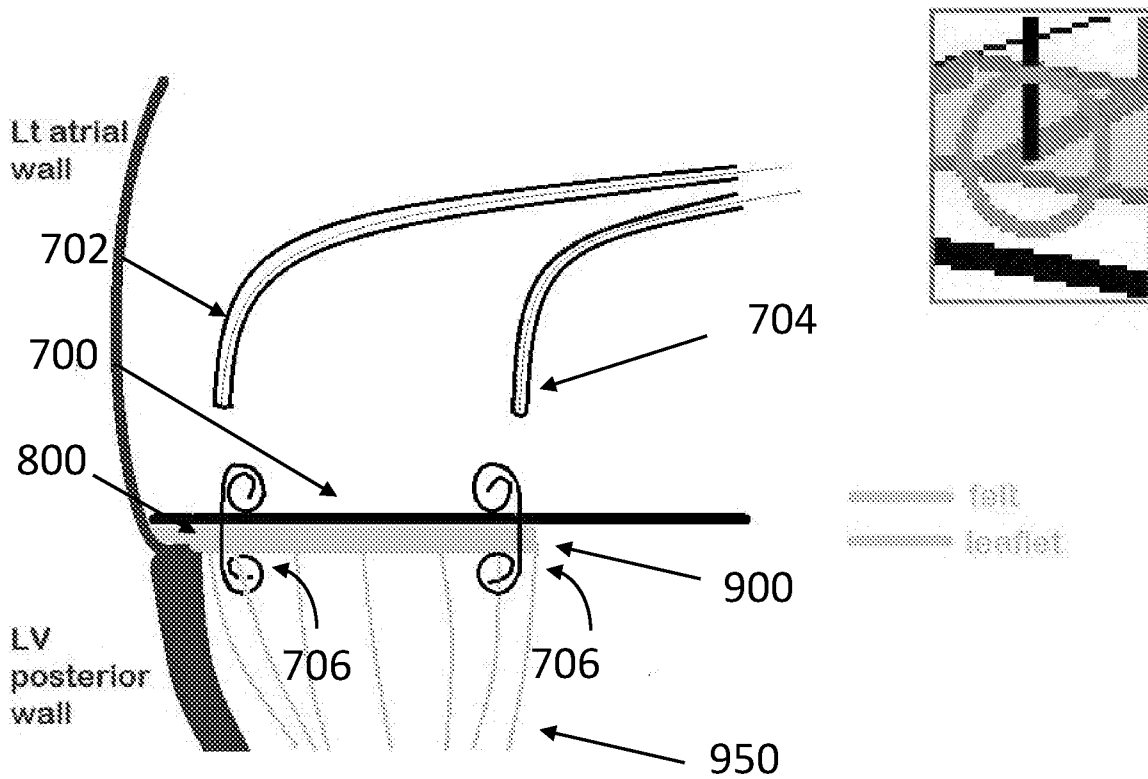
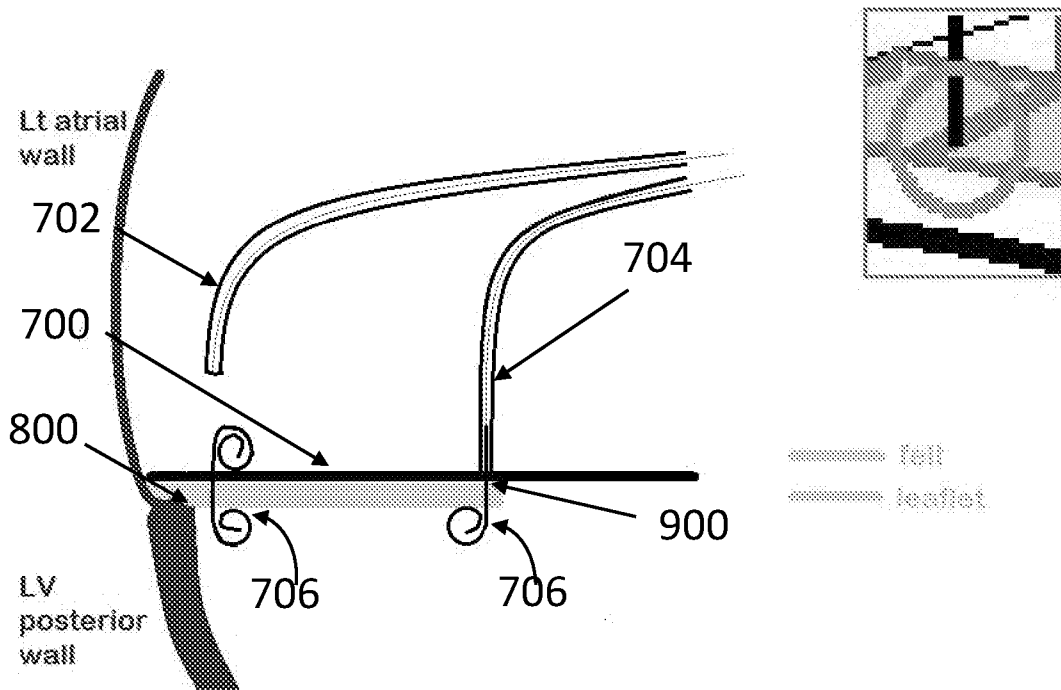

FIG. 7F



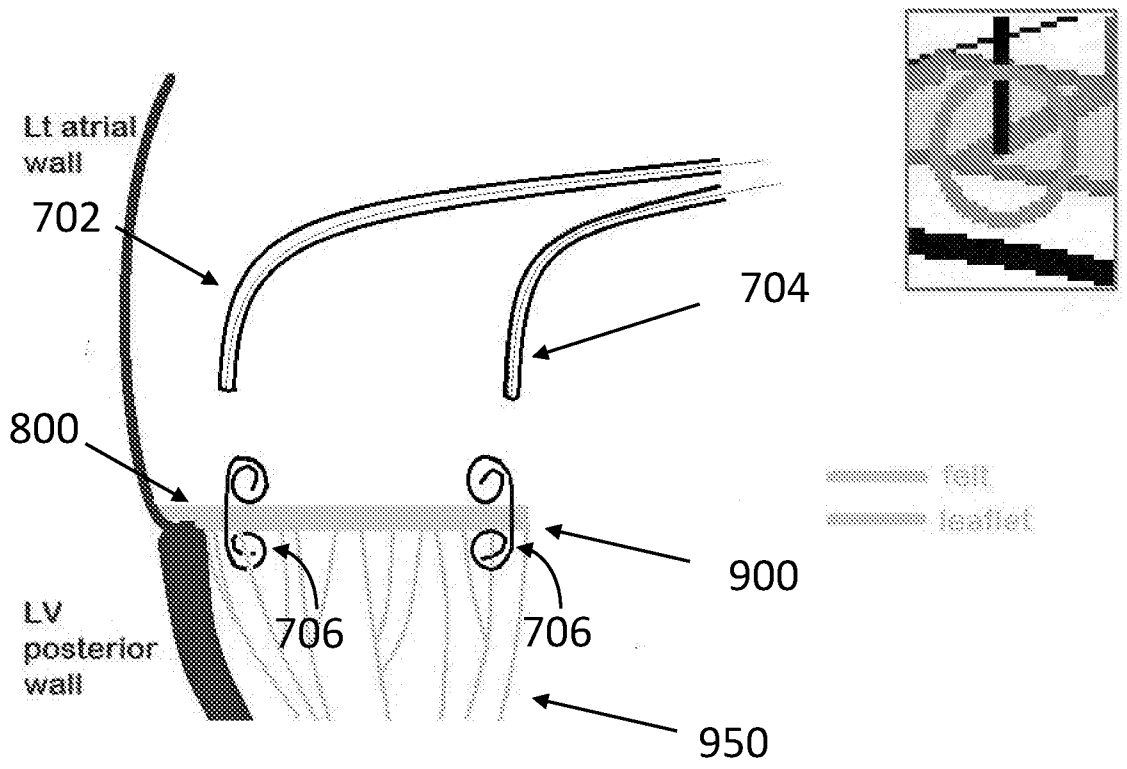

FIG. 7I

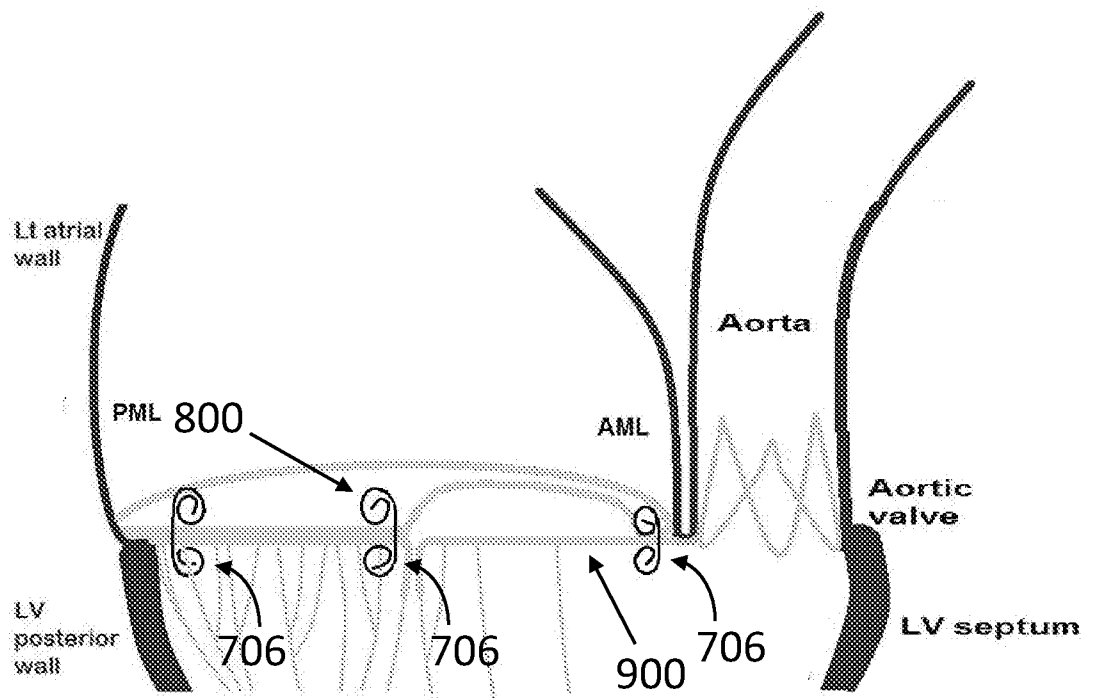

FIG. 7J

17/33

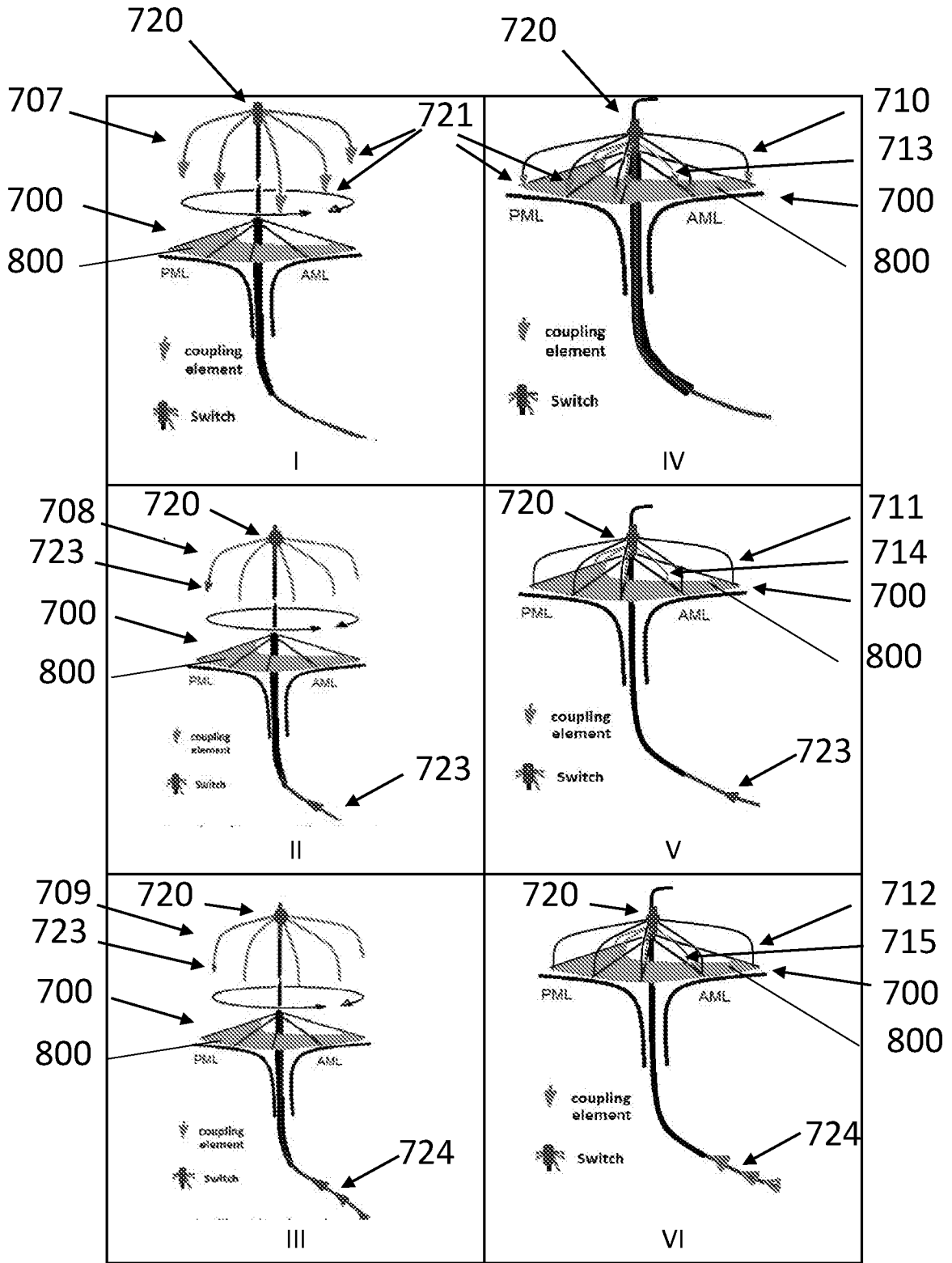

FIG. 7K

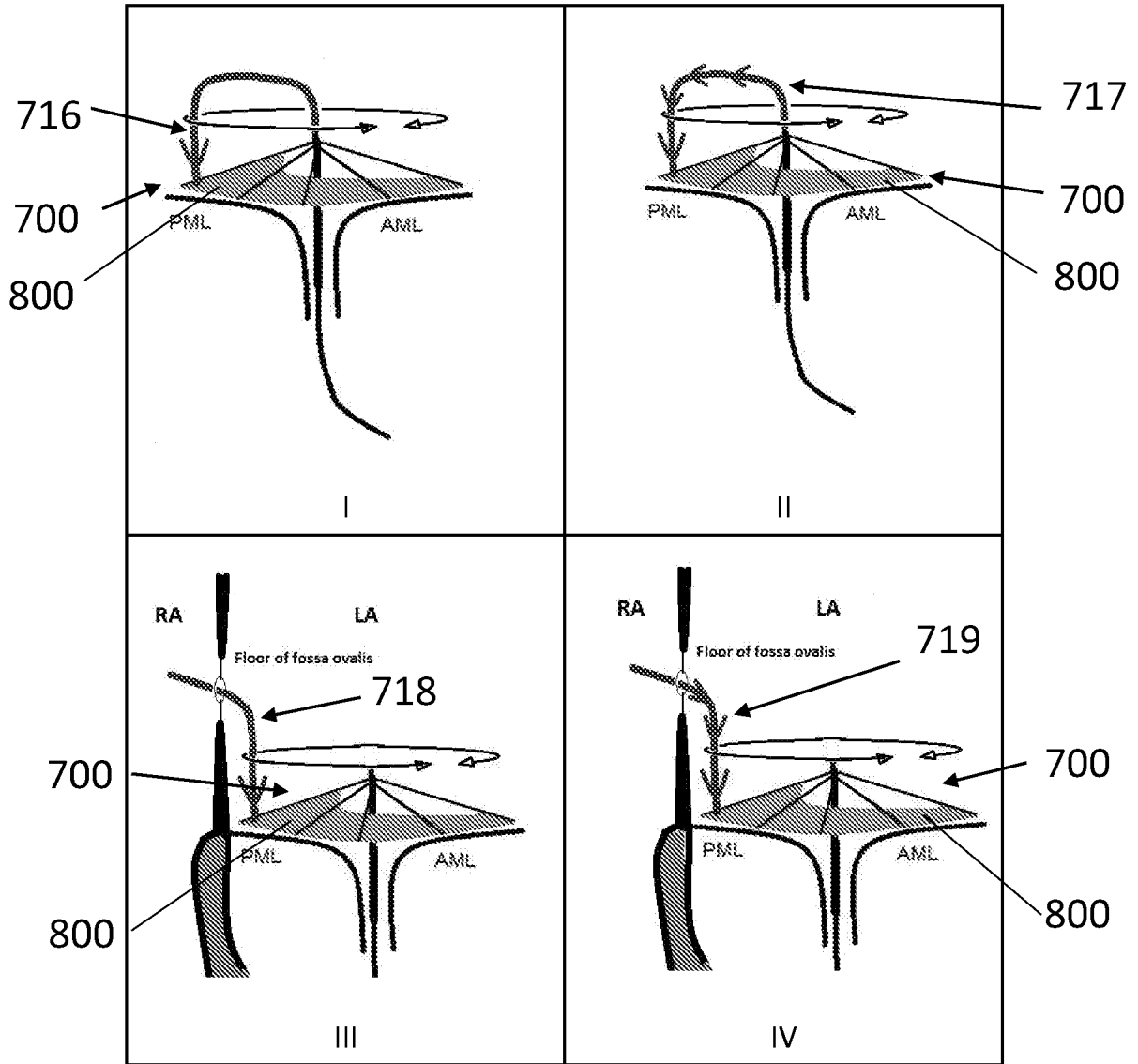

FIG. 7L

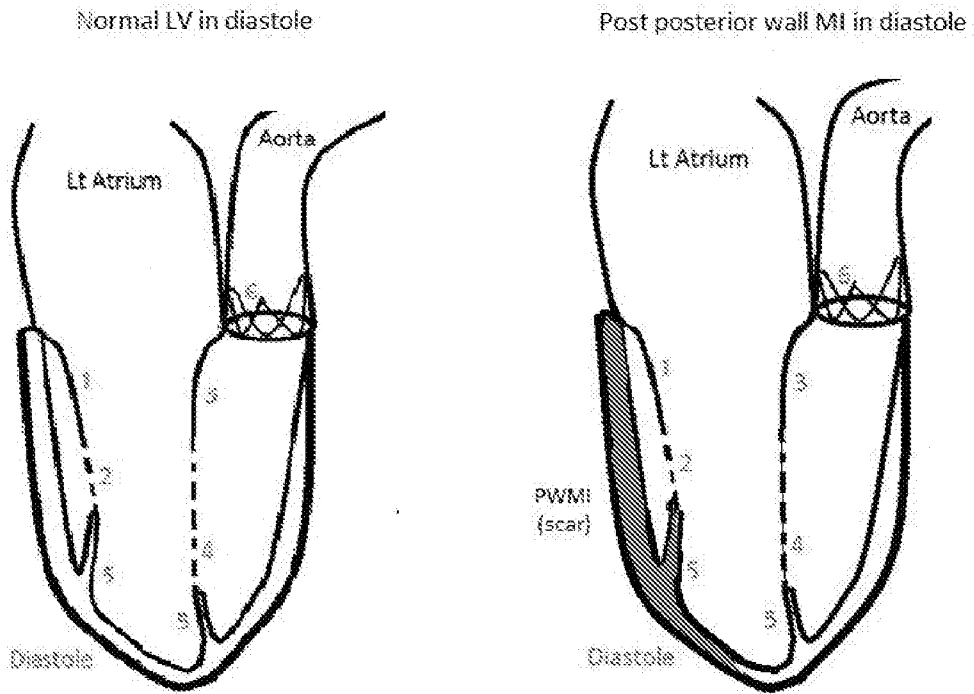

FIG. 8

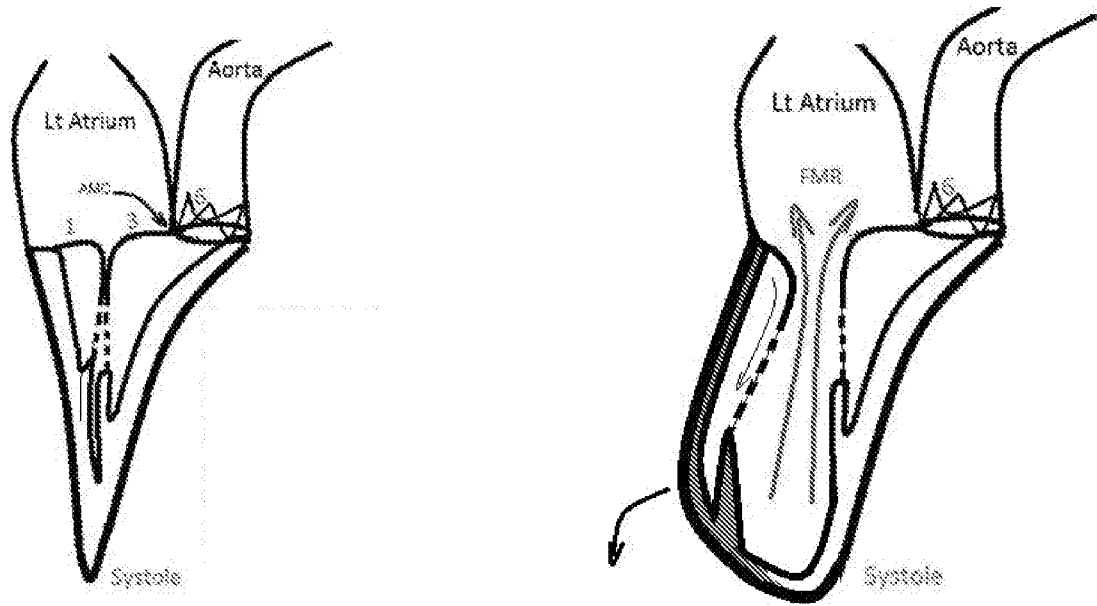
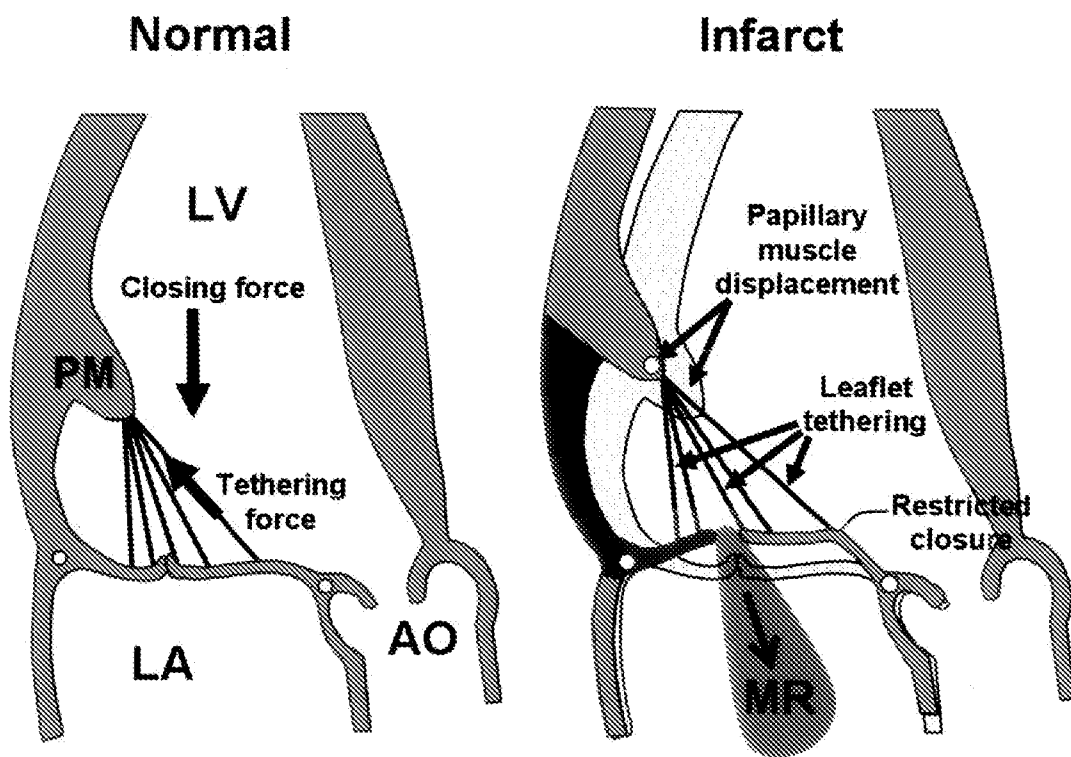

FIG. 9



R. A. Levine, E. Schwammenthal: *Circulation*. 2005;112:745-758

FIG. 10

Normal heart

Heart post posterior MI

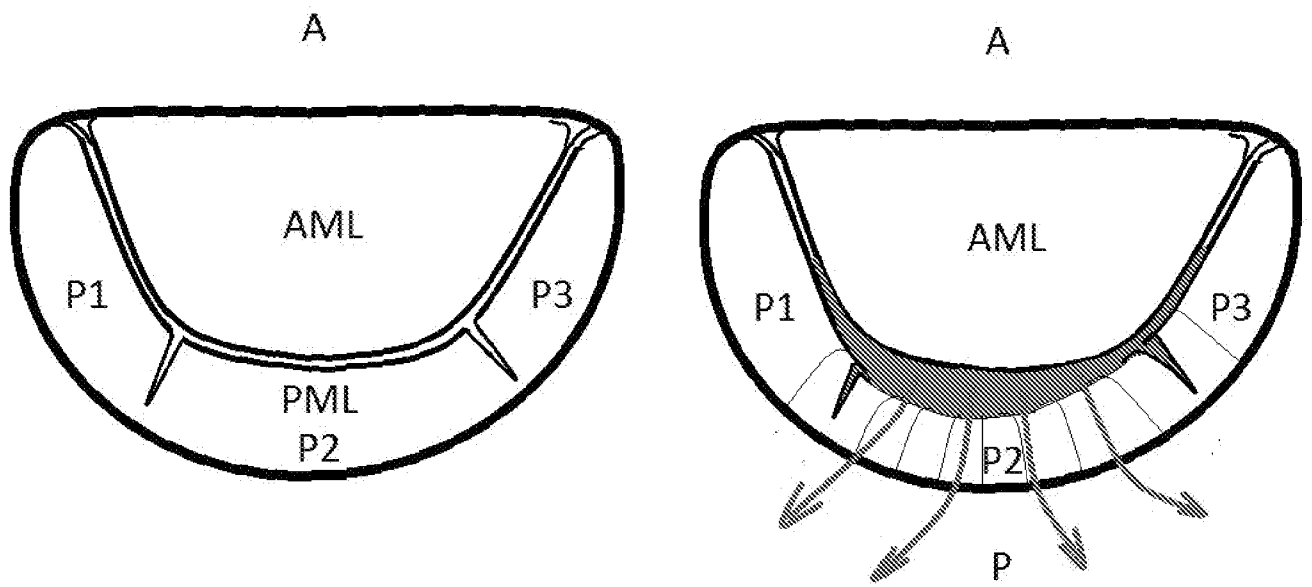

FIG. 11

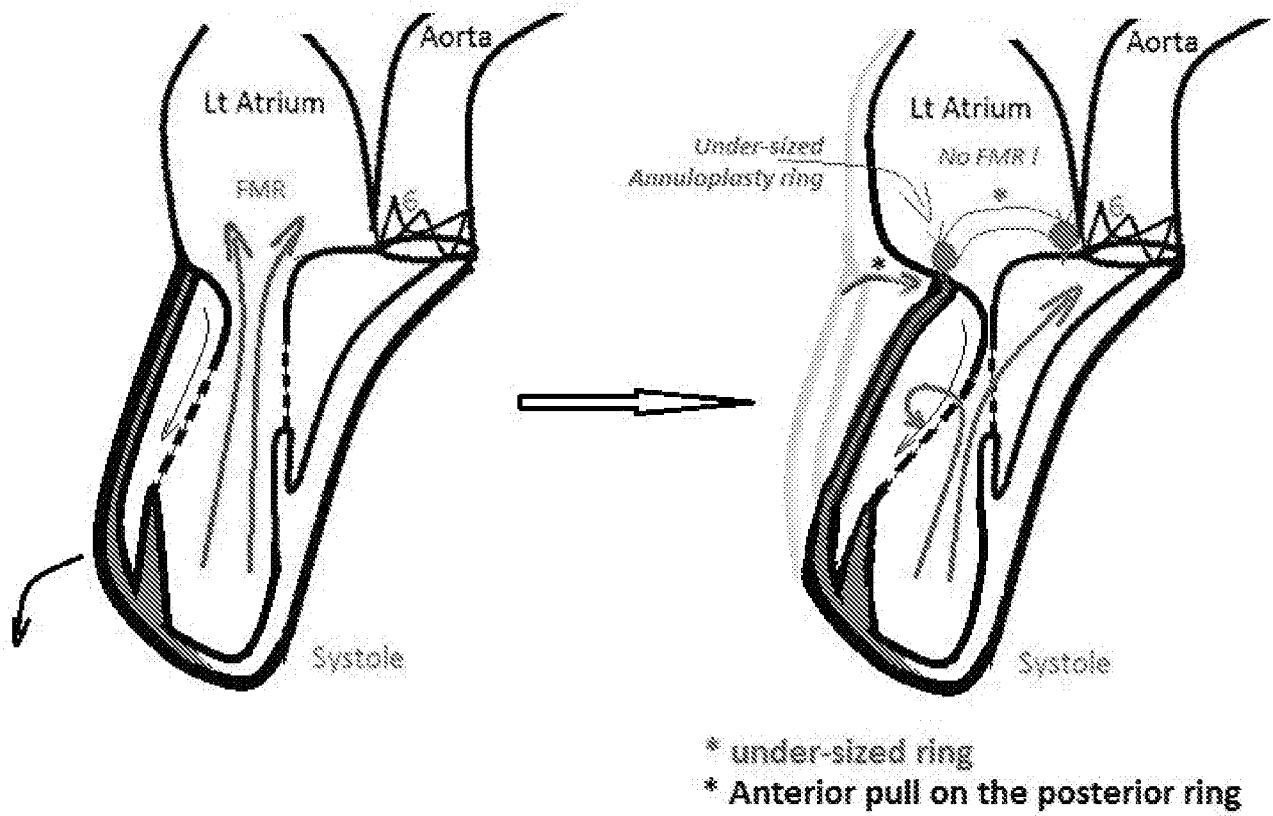

FIG. 12

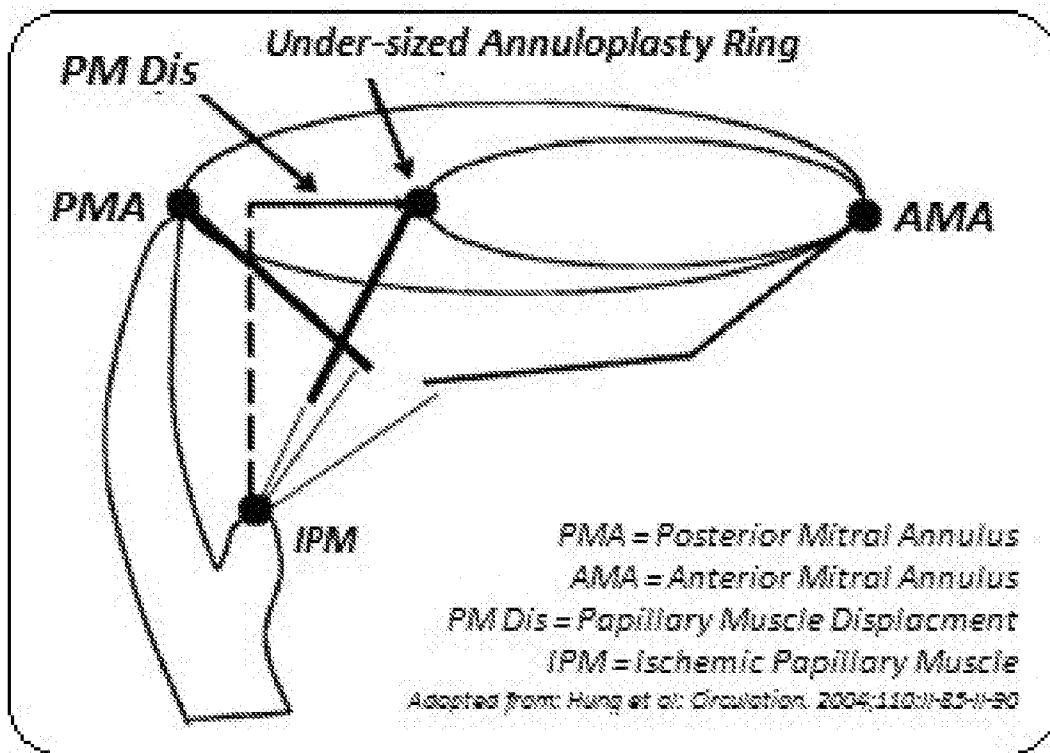
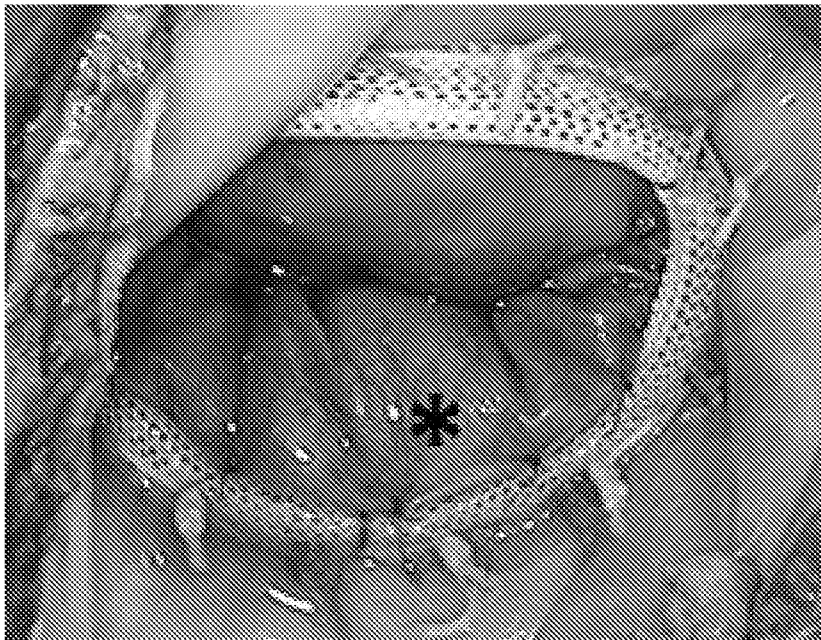

FIG. 13

25/33



S. Mitsuyama et al.: Mitral Valve Repair by Posterior Leaflet Augmentation for Ischemic Mitral regurgitation. In: AATS Mitral Conclave; Breakout Session 9: Surgery for Ischemic Mitral Regurgitation, Thursday, April 27, 2017

FIG. 14

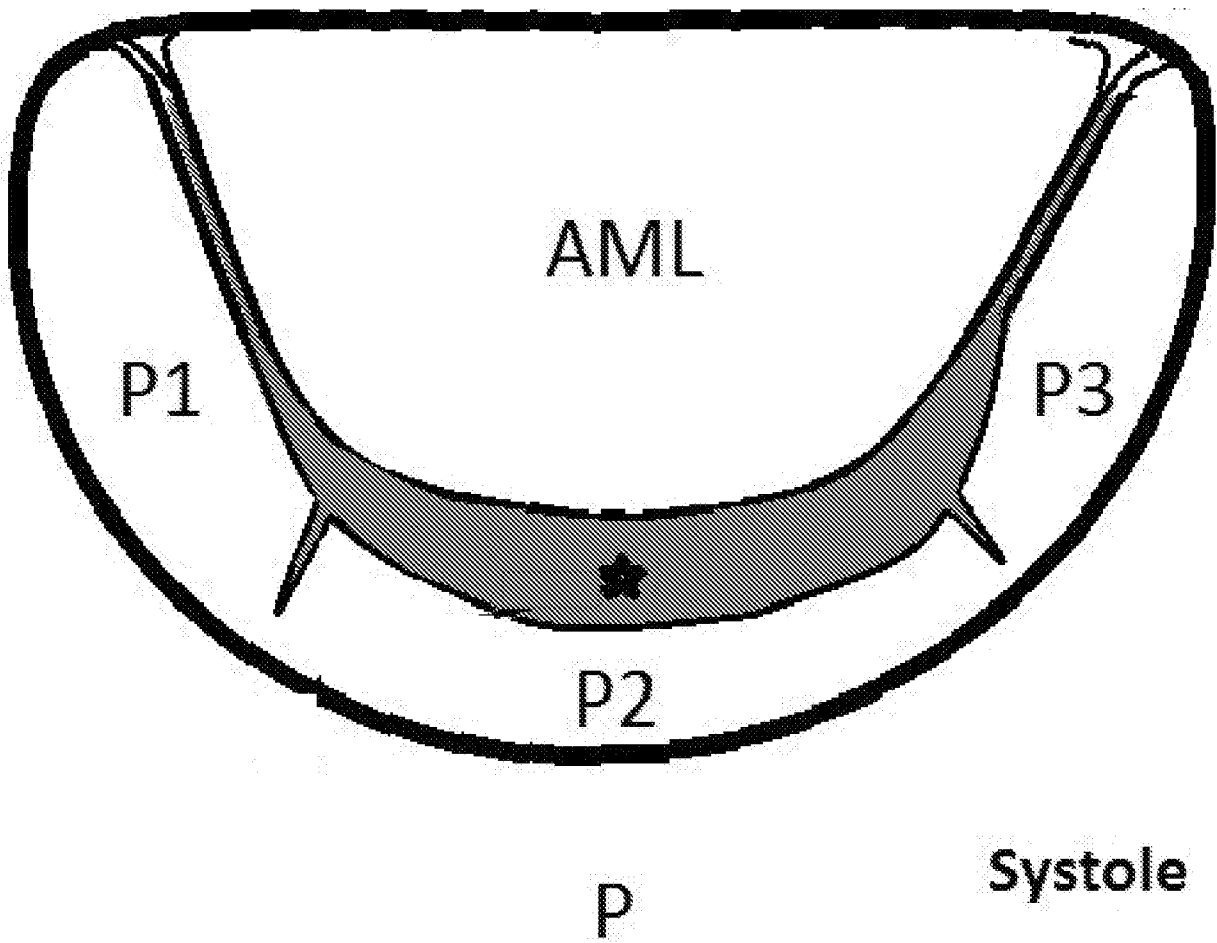

FIG. 15

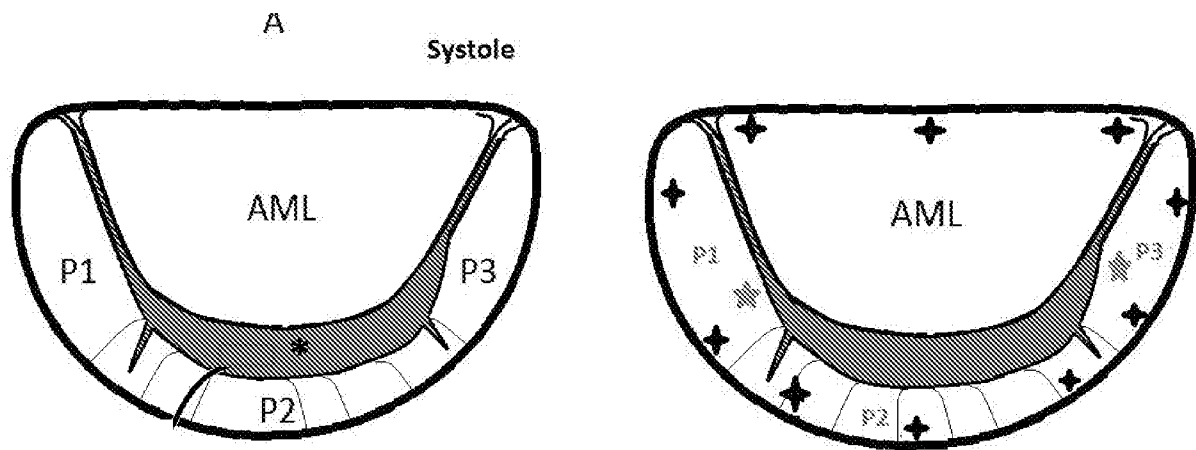

FIG. 16

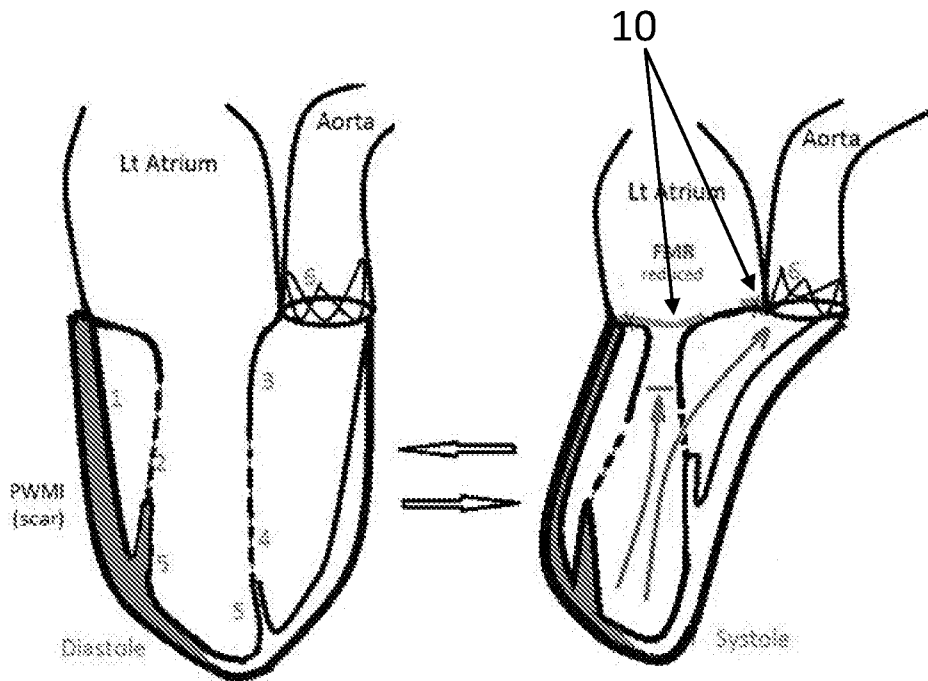

FIG. 17

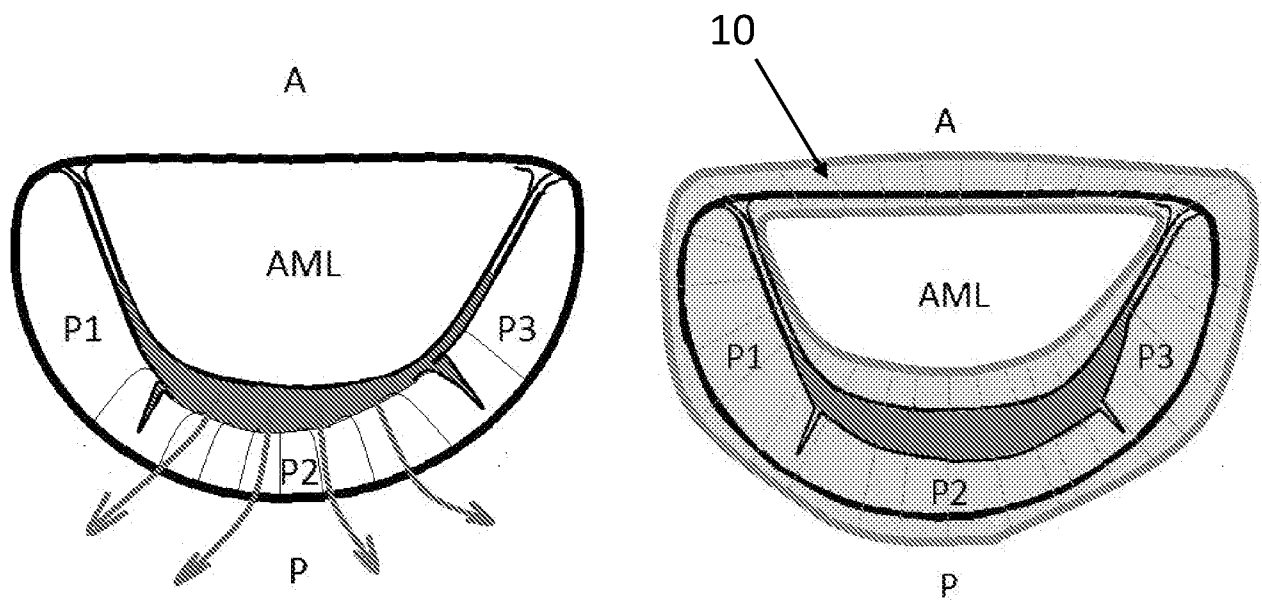
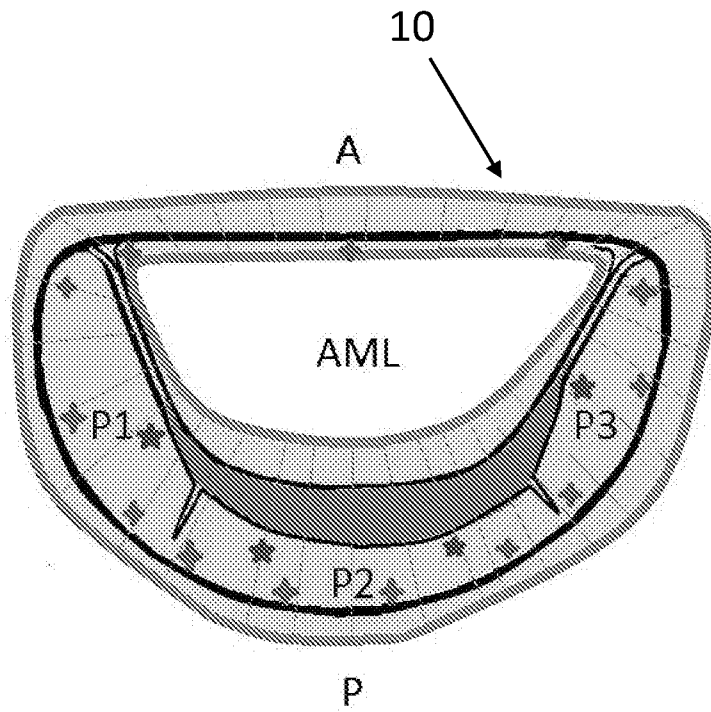

FIG. 18

30/33



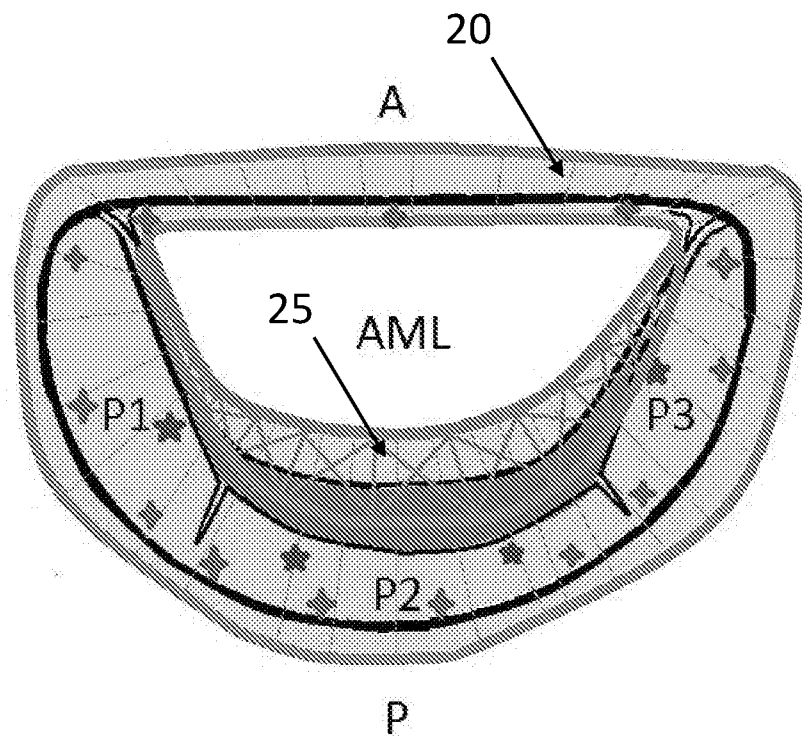

FIG. 20

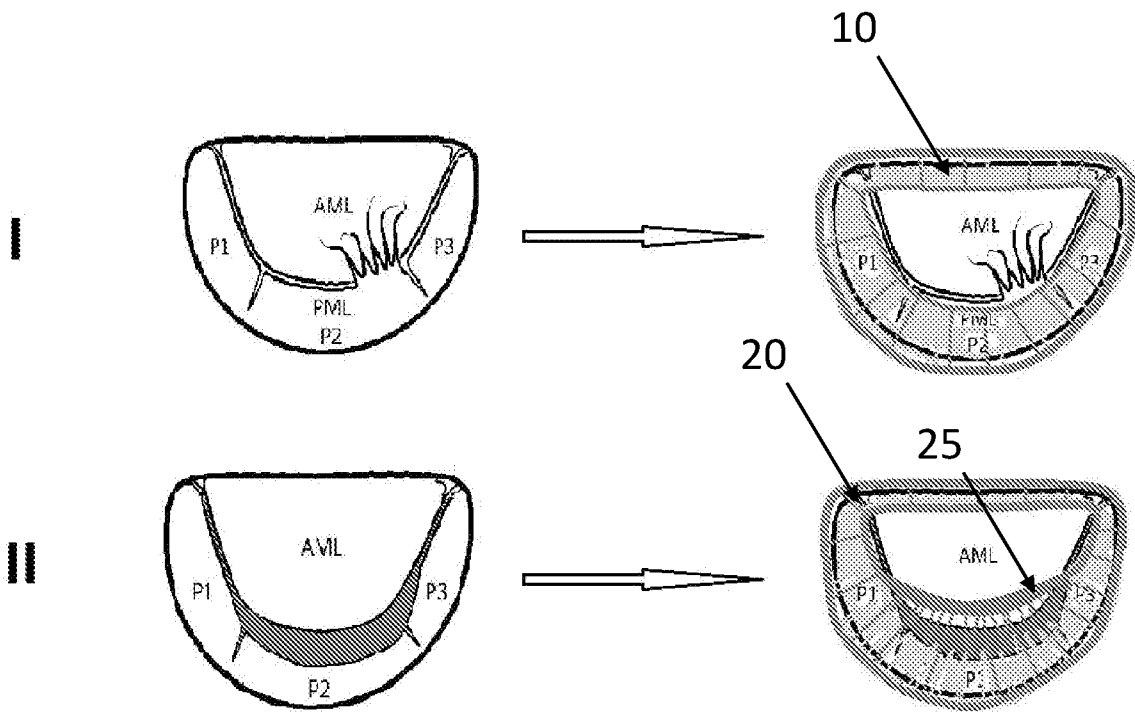

FIG. 21

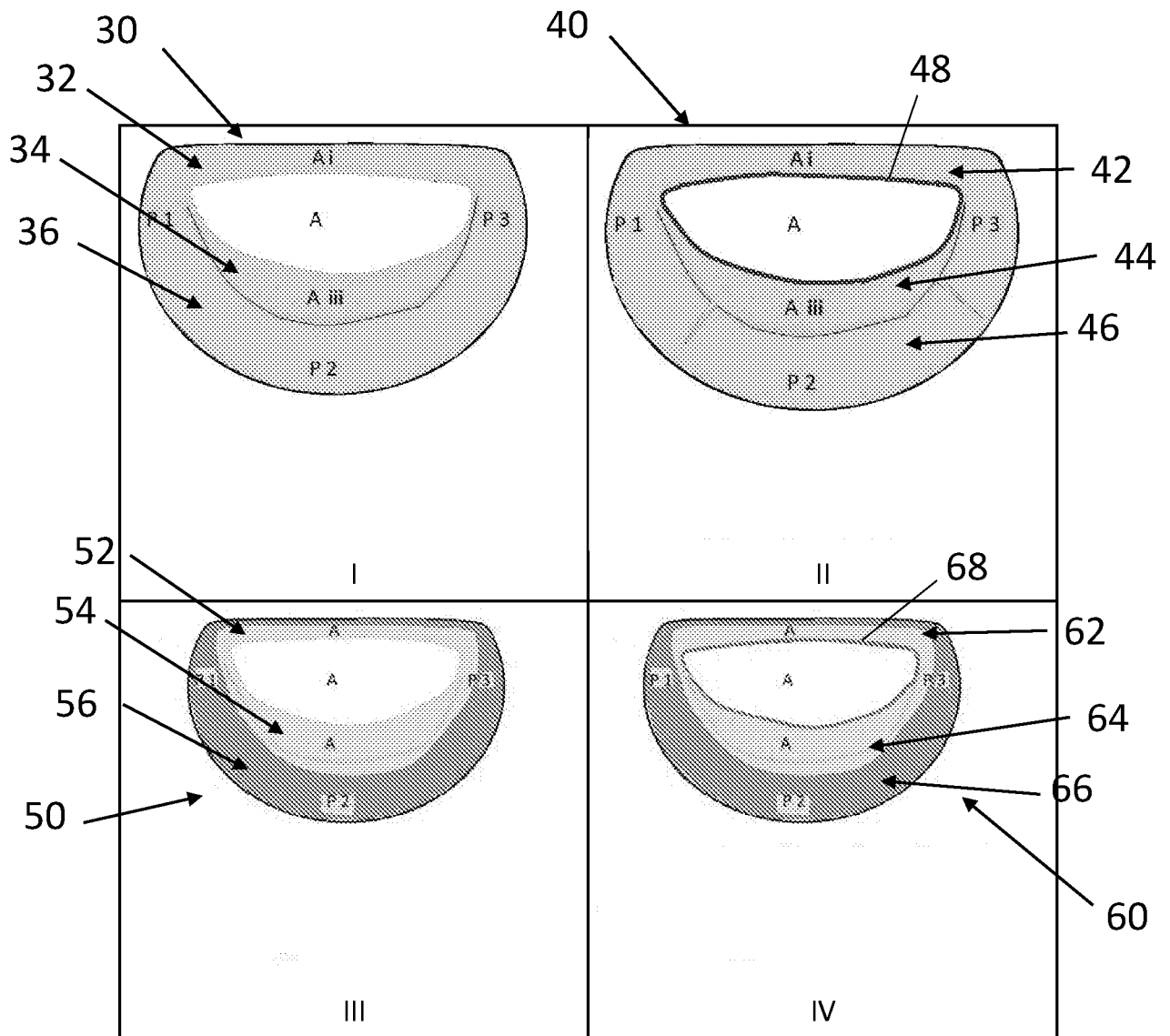

FIG. 22

INTERNATIONAL SEARCH REPORT

International application No.

PCT/IL2018/050351

A. CLASSIFICATION OF SUBJECT MATTER IPC (2018.01) A61F 2/00, A61F 2/24, A61B 17/00, A61B 17/064		
According to International Patent Classification (IPC) or to both national classification and IPC		
B. FIELDS SEARCHED		
Minimum documentation searched (classification system followed by classification symbols) IPC (2018.01) A61F 2/00, A61F 2/24, A61B 17/00, A61B 17/064		
Documentation searched other than minimum documentation to the extent that such documents are included in the fields searched		
Electronic data base consulted during the international search (name of data base and, where practicable, search terms used) Databases consulted: Esp@cenet, Google Patents, Google Scholar, Orbit		
C. DOCUMENTS CONSIDERED TO BE RELEVANT		
Category*	Citation of document, with indication, where appropriate, of the relevant passages	Relevant to claim No.
X	US 6726716 B2 Salvador Marquez 27 Apr 2004 (2004/04/27) col. 1 line 21-39; col.1 line 65-col. 2 line 21; col. 3 line 25-29; fig. 2b, 2e, 3b, 3d,4a, 4b	1-16,22-25
X	US 6368348 B1 Shlomo Gabbay 09 Apr 2002 (2002/04/09) col. 1 line 44-60 ; col. 2 line 1-11; col. 4 lines 15-23; fig. 2; Fig. 6-9,	1-10,12-16,22-25
X	US 5061277 A Alain Carpentier ET AL 29 Oct 1991 (1991/10/29) abstract; col. 1 line 59- col. 2 line 6 ;col. 3 line 49-51; col. 4 lines 33-35; fig. 1, 9-10	1-3,5-7,12-16,22-25
X	US 5104407 A Hung L. Lam ET AL 14 Apr 1992 (1992/04/14) col. 5 line 5-13; col. 6 line 12-29; col. 7 line 52- col. 8 line 5; fig. 1,2,8 ,	1-3,5,12-16,22-25
X	US 6520974 B2 Howard M. Tanner ET AL 18 Feb 2003 (2003/02/18) col. 22, lines 5-24; col. 23 line 50- col. 24 line 10; col. 25 line 63- col. 36 line 4; col. 50, lines 47-63; fig. 36-39	17-21
<input checked="" type="checkbox"/> Further documents are listed in the continuation of Box C. <input checked="" type="checkbox"/> See patent family annex.		
* Special categories of cited documents: "A" document defining the general state of the art which is not considered to be of particular relevance "E" earlier application or patent but published on or after the international filing date "L" document which may throw doubts on priority claim(s) or which is cited to establish the publication date of another citation or other special reason (as specified) "O" document referring to an oral disclosure, use, exhibition or other means "P" document published prior to the international filing date but later than the priority date claimed "T" later document published after the international filing date or priority date and not in conflict with the application but cited to understand the principle or theory underlying the invention "X" document of particular relevance; the claimed invention cannot be considered novel or cannot be considered to involve an inventive step when the document is taken alone "Y" document of particular relevance; the claimed invention cannot be considered to involve an inventive step when the document is combined with one or more other such documents, such combination being obvious to a person skilled in the art "&" document member of the same patent family		
Date of the actual completion of the international search 04 Jul 2018		Date of mailing of the international search report 04 Jul 2018
Name and mailing address of the ISA: Israel Patent Office Technology Park, Bldg.5, Malcha, Jerusalem, 9695101, Israel Facsimile No. 972-2-5651616		Authorized officer SHUSHAN Hadas HadasShu@justice.gov.il Telephone No. 972-2-5657813

INTERNATIONAL SEARCH REPORT

International application No.

PCT/IL2018/050351

C (Continuation). DOCUMENTS CONSIDERED TO BE RELEVANT

Category*	Citation of document, with indication, where appropriate, of the relevant passages	Relevant to claim No.
X	US 8382653 B2 Corassist Cardiovascular Ltd. 26 Feb 2013 (2013/02/26) figs. 1, 3b, 4b, 5b, 6c, 7	17-21

Box No. III Observations where unity of invention is lacking (Continuation of item 3 of first sheet)

This International Searching Authority found multiple inventions in this international application, as follows:

See extra sheet.

1. As all required additional search fees were timely paid by the applicant, this international search report covers all searchable claims.
2. As all searchable claims could be searched without effort justifying additional fees, this Authority did not invite payment of additional fees.
3. As only some of the required additional search fees were timely paid by the applicant, this international search report covers only those claims for which fees were paid, specifically claims Nos.:
4. No required additional search fees were timely paid by the applicant. Consequently, this international search report is restricted to the invention first mentioned in the claims; it is covered by claims Nos.:

Remark on Protest

- The additional search fees were accompanied by the applicant's protest and, where applicable, the payment of a protest fee.
- The additional search fees were accompanied by the applicant's protest but the applicable protest fee was not paid within the time limit specified in the invitation.
- No protest accompanied the payment of additional search fees.

Box No. III Observations where unity of invention is lacking (Continuation of item 3 of first sheet):

* This International Searching Authority found multiple inventions in this international application, as follows:

Invention/s 1 a supra mitral device for mitral/tricuspid valve repair in a subject in need thereof, the device Claim/s 1-16,19,21,22,24,25

comprising a main body portion having essentially annular D-shape with an eccentric opening, such that a posterior section of said main body portion is wider than an anterior section of said main body portion, said posterior section of said main body portion configured for coverage and attachment to essentially the whole section of the posterior leaflet of the mitral valve which faces the left atrium on systole, thereby preventing and/or reducing mitral regurgitation, wherein said posterior section of said main body portion is made of a pliable material, adapted to stiffen after implantation of the device. A method for per cutaneous Mitral valve replacement comprising attaching said device and a kit comprising said device

Invention/s 2 a coupling element comprising a wire comprising a memory shape material configured to assume a Claim/s 17-21,23,24

spiral shape; wherein the spiral comprises a first spiral and a second spiral interconnected by an essentially straight wire; wherein a distal end of the first end forms the innermost loop/the outermost loop of the first spiral, and a proximal end of the first end forms the outermost loop/the innermost loop of the first spiral; and wherein a distal end of the second end forms the outermost loop/the innermost loop of the second spiral and a proximal end of the second end forms the innermost loop/the outermost loop of the second spiral and a method for per cutaneous Mitral valve replacement comprising said coupling elements

INTERNATIONAL SEARCH REPORT
Information on patent family members

International application No.
PCT/IL2018/050351

Patent document cited search report	Publication date	Patent family member(s)	Publication Date
US 6726716 B2	27 Apr 2004	US 2003040793 A1	27 Feb 2003
		US 6726716 B2	27 Apr 2004
		AT 446727 T	15 Nov 2009
		CA 2456991 A1	06 Mar 2003
		DE 60234189 D1	10 Dec 2009
		EP 1418865 A1	19 May 2004
		EP 1418865 B1	28 Oct 2009
		EP 2133040 A2	16 Dec 2009
		EP 2133040 A3	15 Aug 2012
		US 2004162611 A1	19 Aug 2004
		US 7063722 B2	20 Jun 2006
		US 2006184241 A1	17 Aug 2006
		WO 03017874 A1	06 Mar 2003
US 6368348 B1	09 Apr 2002	US 6368348 B1	09 Apr 2002
		CA 2409475 A1	22 Nov 2001
		EP 1294317 A1	26 Mar 2003
		EP 1294317 A4	09 Aug 2006
		JP 2003533275 A	11 Nov 2003
		WO 0187191 A1	22 Nov 2001
US 5061277 A	29 Oct 1991	US 5061277 A	29 Oct 1991
		US 5061277 B1	29 Feb 2000
		CA 1303298 C	16 Jun 1992
		DE 3778247 D1	21 May 1992
		EP 0257874 A1	02 Mar 1988
		EP 0257874 B1	15 Apr 1992
		JP S63109856 A	14 May 1988
		JP 2619400 B2	11 Jun 1997
US 5104407 A	14 Apr 1992	US 5104407 A	14 Apr 1992

INTERNATIONAL SEARCH REPORT
Information on patent family members

International application No.
PCT/IL2018/050351

Patent document cited search report	Publication date	Patent family member(s)	Publication Date
		US 5104407 B1	21 Sep 1999
		CA 2049971 A1	14 Aug 1990
		CA 2049971 C	21 Aug 2001
		CA 2330419 A1	14 Aug 1990
		CA 2330419 C	27 Nov 2001
		DE 69010890 D1	25 Aug 1994
		DE 69010890 T2	16 Mar 1995
		DE 69033195 D1	05 Aug 1999
		DE 69033195 T2	09 Mar 2000
		EP 0457842 A1	27 Nov 1991
		EP 0457842 B1	20 Jul 1994
		EP 0595791 A2	04 May 1994
		EP 0595791 A3	22 Jun 1994
		EP 0595791 B1	30 Jun 1999
		JP H04503318 A	18 Jun 1992
		JP 3174883 B2	11 Jun 2001
		WO 9009153 A1	23 Aug 1990
US 6520974 B2	18 Feb 2003	US 2002026214 A1	28 Feb 2002
		US 6520974 B2	18 Feb 2003
		AU 3494801 A	20 Aug 2001
		AU 8262998 A	19 Jan 1999
		AU 2001234948 B2	08 Sep 2005
		AU 2003214209 A1	08 Oct 2003
		CA 2398096 A1	16 Aug 2001
		EP 0991357 A2	12 Apr 2000
		EP 0991357 A4	07 May 2008
		EP 1139879 A1	10 Oct 2001
		EP 1171041 A1	16 Jan 2002
		EP 1229842 A1	14 Aug 2002
		EP 1229842 A4	09 Apr 2008

INTERNATIONAL SEARCH REPORT
Information on patent family members

International application No.
PCT/IL2018/050351

Patent document cited search report	Publication date	Patent family member(s)	Publication Date
		EP 1253860 A1	06 Nov 2002
		EP 1253860 A4	26 Apr 2006
		EP 1494615 A1	12 Jan 2005
		EP 1897504 A2	12 Mar 2008
		EP 1897504 A3	07 May 2008
		JP 2001509398 A	24 Jul 2001
		JP 2002532128 A	02 Oct 2002
		JP 2002541900 A	10 Dec 2002
		JP 2003513739 A	15 Apr 2003
		JP 2003521989 A	22 Jul 2003
		JP 2005520627 A	14 Jul 2005
		US 5944750 A	31 Aug 1999
		US 5957940 A	28 Sep 1999
		US 5997556 A	07 Dec 1999
		US 6248118 B1	19 Jun 2001
		US 6270516 B1	07 Aug 2001
		US 6371919 B1	16 Apr 2002
		US 2001016748 A1	23 Aug 2001
		US 6635066 B2	21 Oct 2003
		US 2003195607 A1	16 Oct 2003
		US 2005043785 A1	24 Feb 2005
		US 2007010875 A1	11 Jan 2007
		WO 0035350 A1	22 Jun 2000
		WO 0062679 A1	26 Oct 2000
		WO 0135835 A1	25 May 2001
		WO 0158364 A1	16 Aug 2001
		WO 0158364 A9	24 Oct 2002
		WO 9900055 A2	07 Jan 1999
		WO 9900055 A3	18 Mar 1999
		WO 03079935 A1	02 Oct 2003

INTERNATIONAL SEARCH REPORT
Information on patent family members

International application No.
PCT/IL2018/050351

Patent document cited search report	Publication date	Patent family member(s)	Publication Date
US 8382653 B2	26 Feb 2013	US 2010022821 A1	28 Jan 2010
		US 8382653 B2	26 Feb 2013
		AU 2007301475 A1	03 Apr 2008
		AU 2007301475 B2	18 Apr 2013
		CA 2663833 A1	03 Apr 2008
		CA 2663833 C	07 Oct 2014
		EP 2068768 A2	17 Jun 2009
		EP 2068768 A4	08 Jan 2014
		IL 197670 D0	24 Dec 2009
		IL 197670 A	28 Jun 2012
		JP 2010504137 A	12 Feb 2010
		JP 5313902 B2	09 Oct 2013
		WO 2008038276 A2	03 Apr 2008
		WO 2008038276 A3	16 Sep 2010