



(19) **United States**

(12) **Patent Application Publication** (10) **Pub. No.: US 2019/0108194 A1**

Hewitt et al.

(43) **Pub. Date: Apr. 11, 2019**

(54) **GENERATING A REPRESENTATION OF HIGH-FREQUENCY SIGNAL DATA FROM AN ELECTRIC POWER DELIVERY SYSTEM**

(52) **U.S. Cl.**
CPC *G06F 17/18* (2013.01); *G06Q 50/06* (2013.01); *G01R 31/088* (2013.01)

(71) Applicant: **Schweitzer Engineering Laboratories, Inc.**, Pullman, WA (US)

(57) **ABSTRACT**

(72) Inventors: **Eric J. Hewitt**, Moscow, ID (US);
Matthew J. Halladay, Moscow, ID (US)

A system, method, and computer program product are provided for representation of high-frequency signal data. In use, input data is received including high-frequency signals, wherein the input data is of a first width. Next, the input data is processed to manage display of the input data, where specifically the input data is divided into one or more segments based on first criteria including the first width, and from each segment of the one or more segments, a maximum value is identified and a minimum value is identified. Still yet, the input data is transformed to a visualizable representation of the high-frequency signals, the visualizable representation of the high-frequency signals including a plot of the maximum value and the minimum value for each segment of the one or more segments. Additionally, the plot is displayed.

(73) Assignee: **Schweitzer Engineering Laboratories, Inc.**, Pullman, WA (US)

(21) Appl. No.: **15/727,012**

(22) Filed: **Oct. 6, 2017**

Publication Classification

(51) **Int. Cl.**
G06F 17/18 (2006.01)
G01R 31/08 (2006.01)
G06Q 50/06 (2006.01)

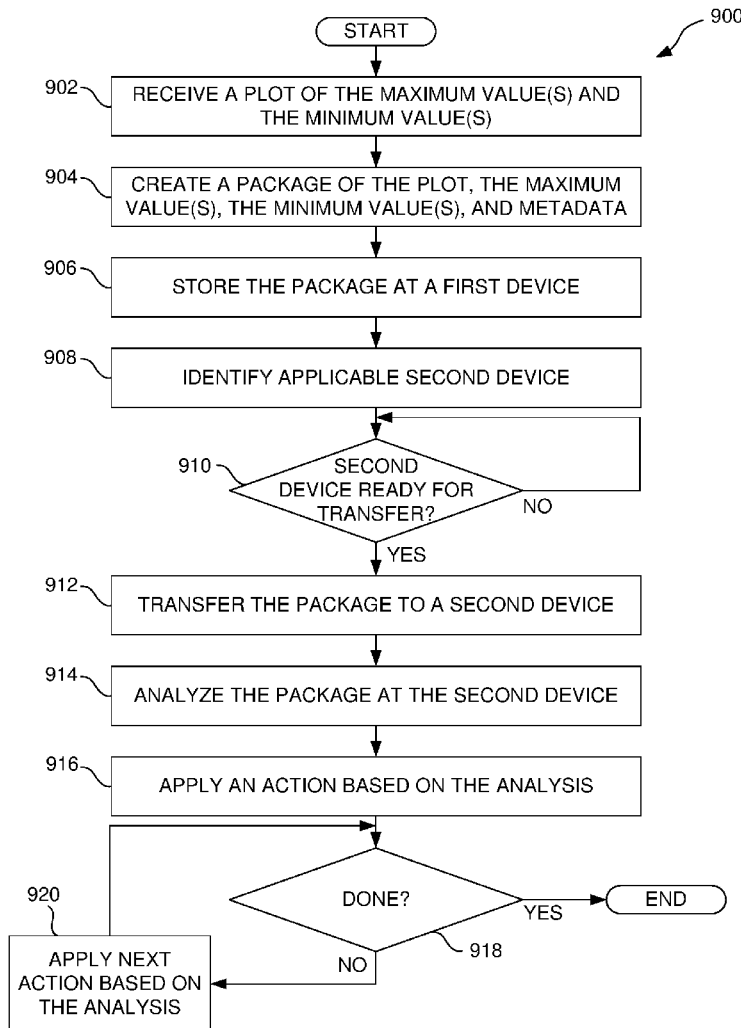

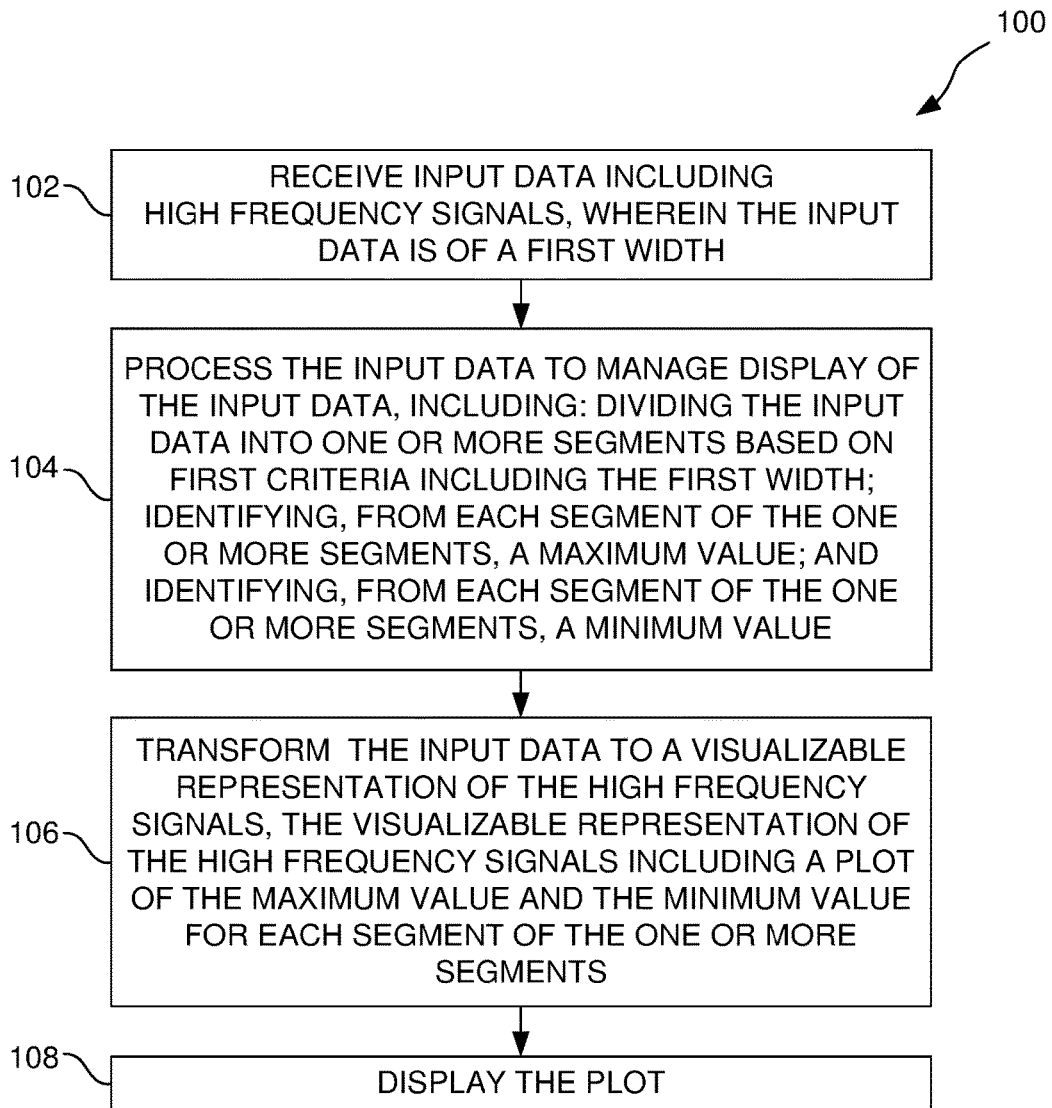

FIGURE 1

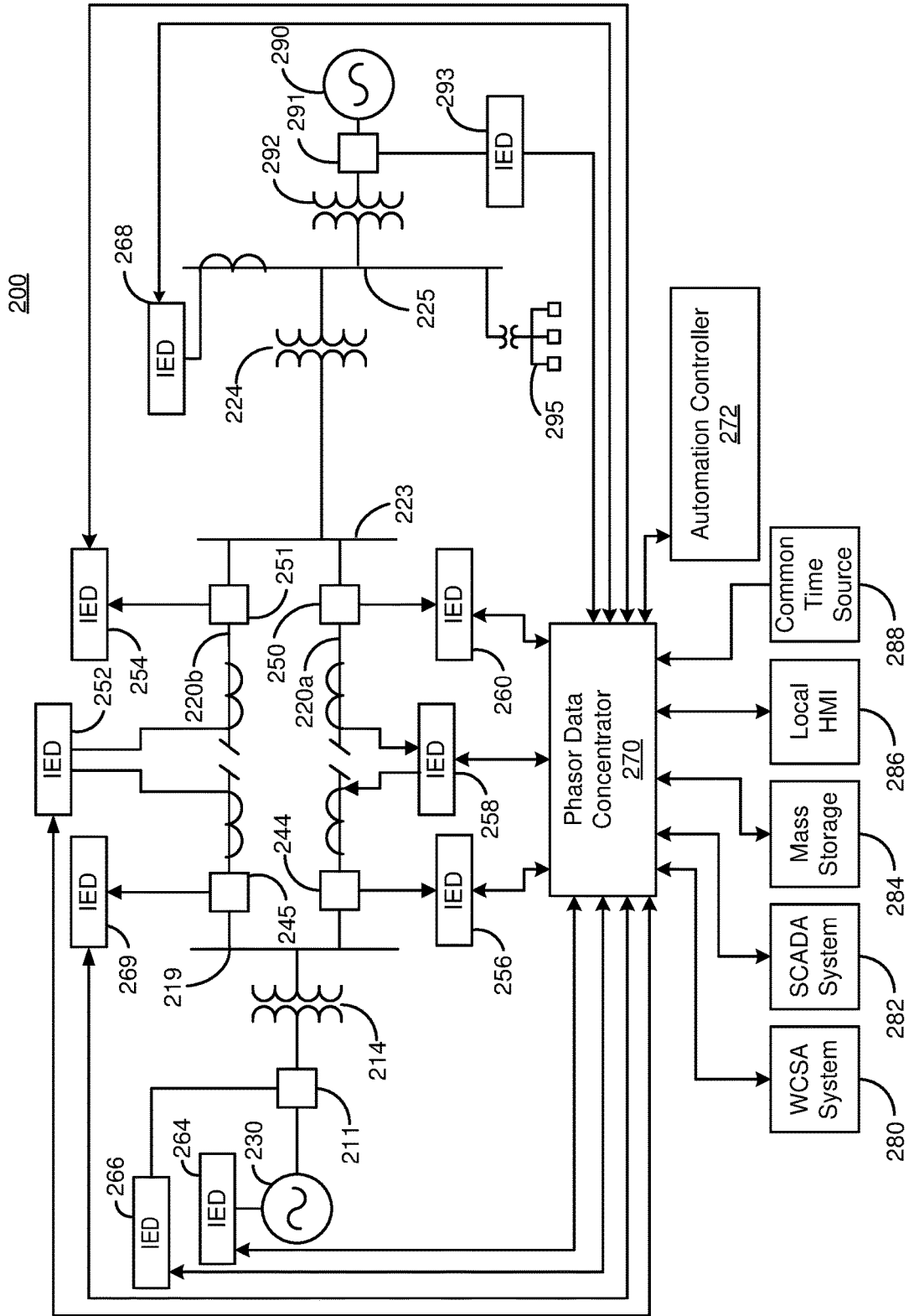

FIGURE 2

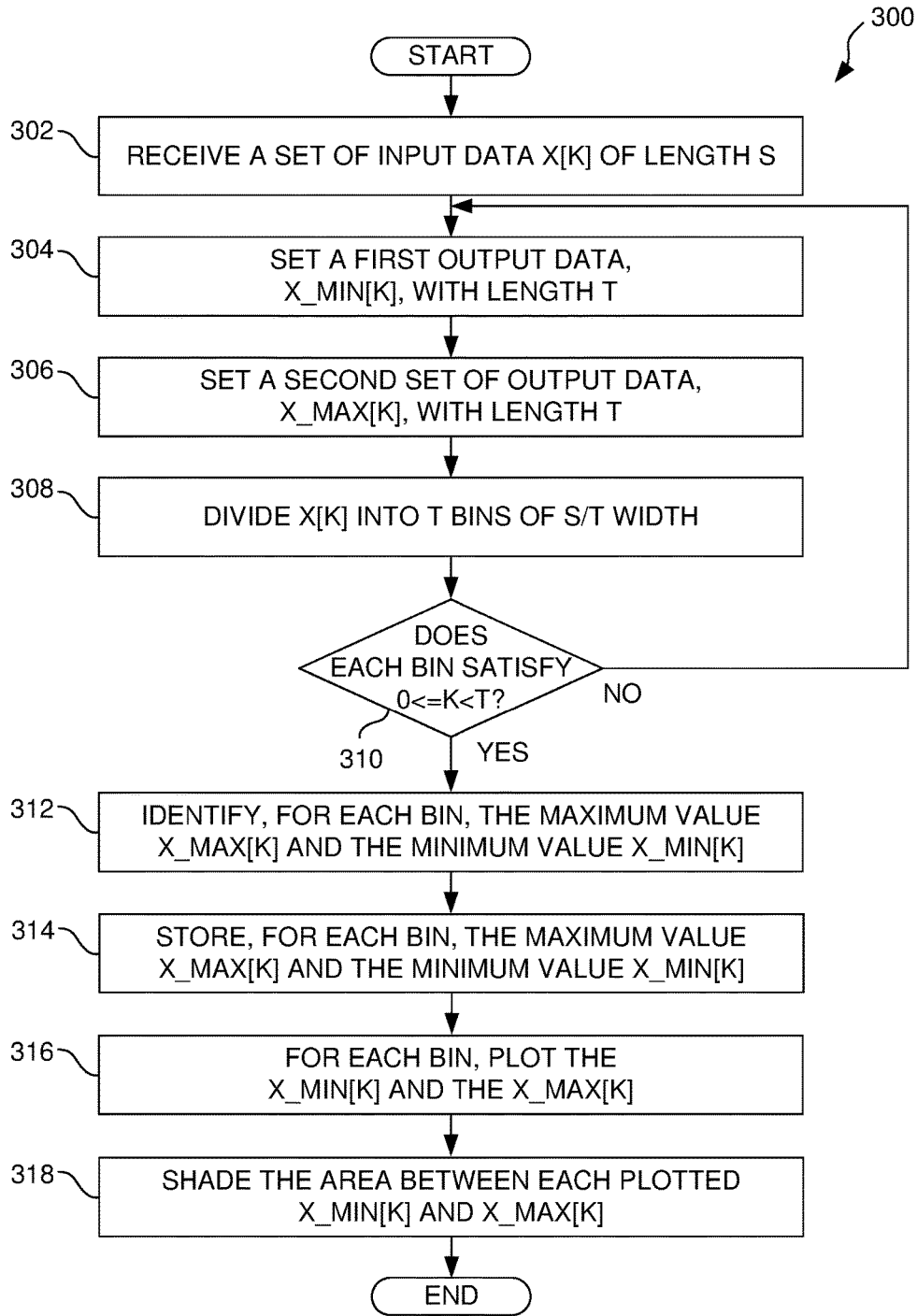

FIGURE 3

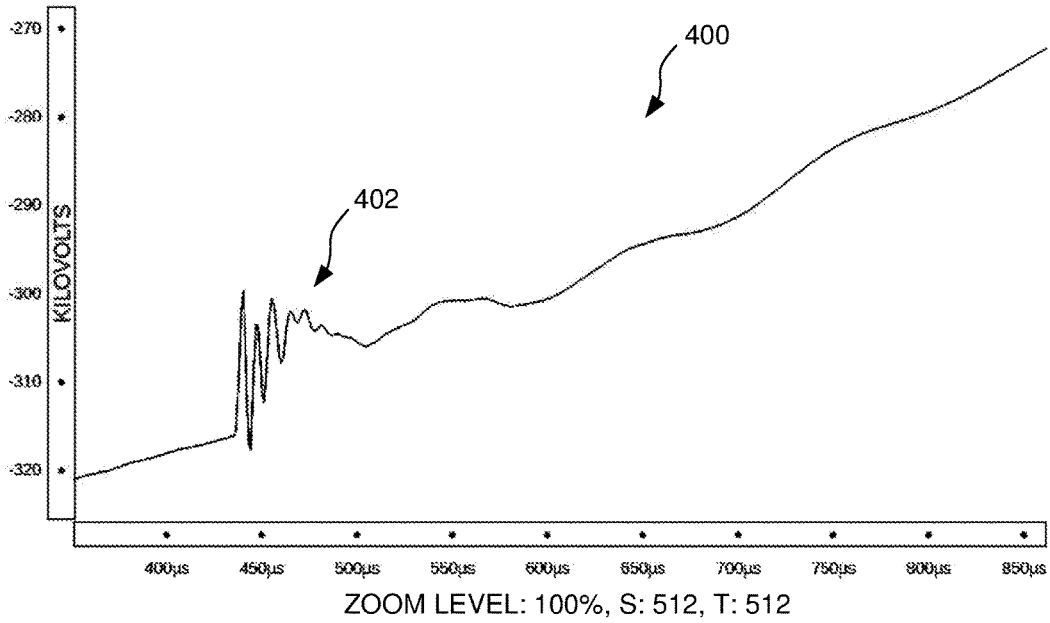

FIGURE 4A

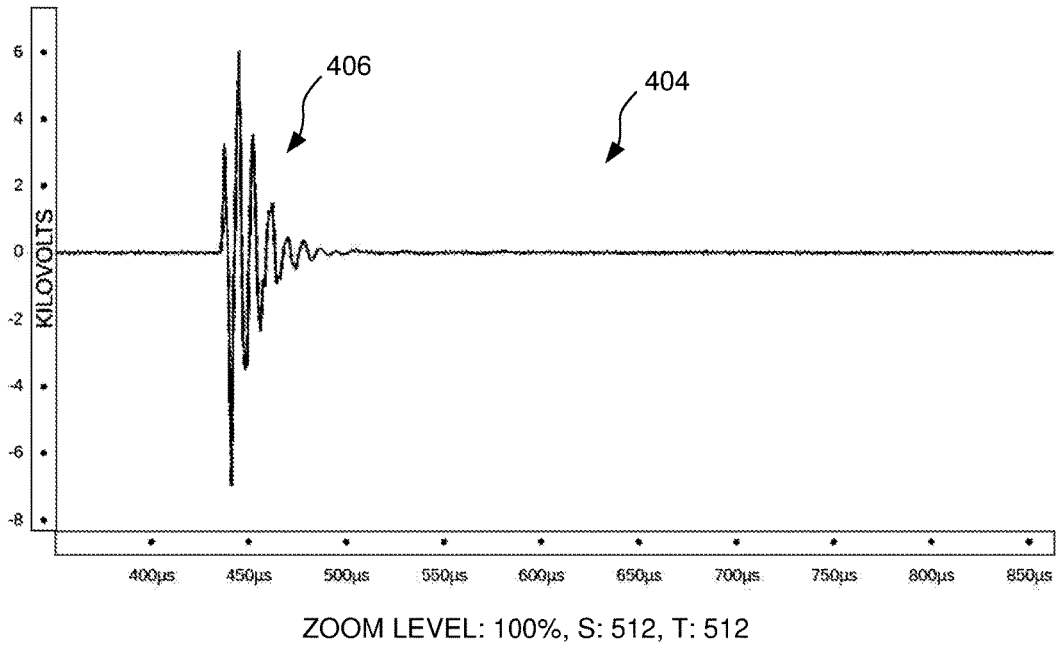

FIGURE 4B

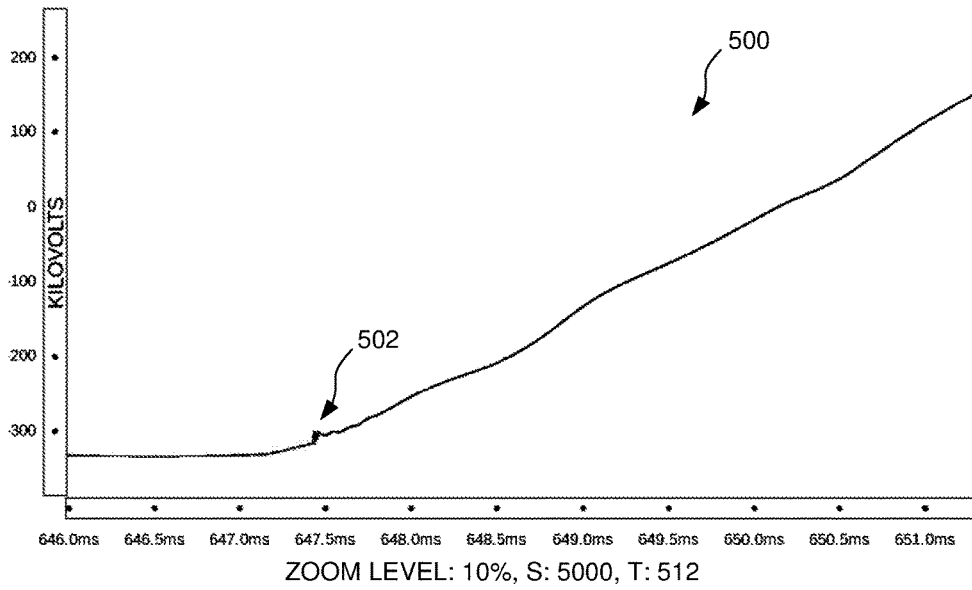

FIGURE 5A

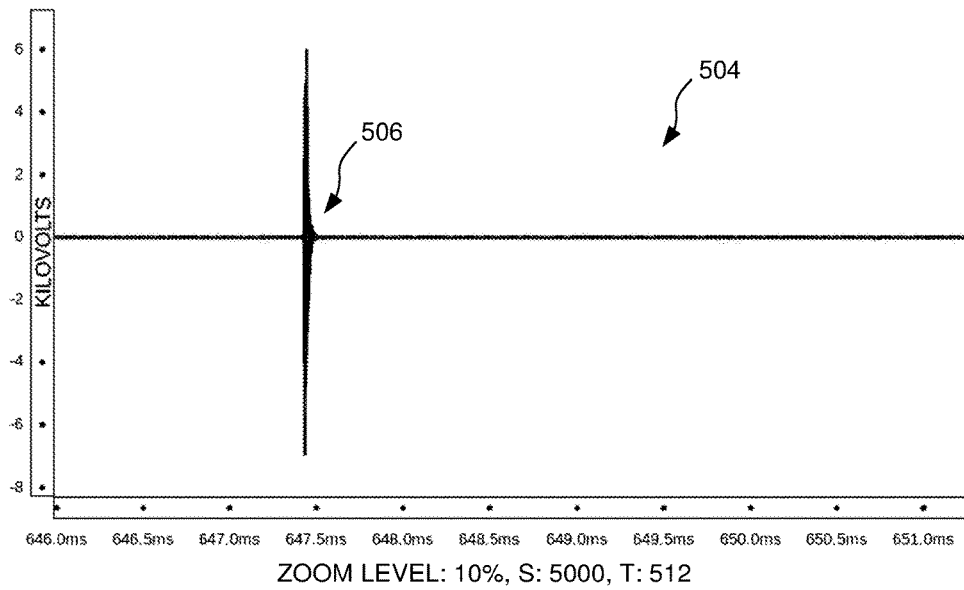

FIGURE 5B

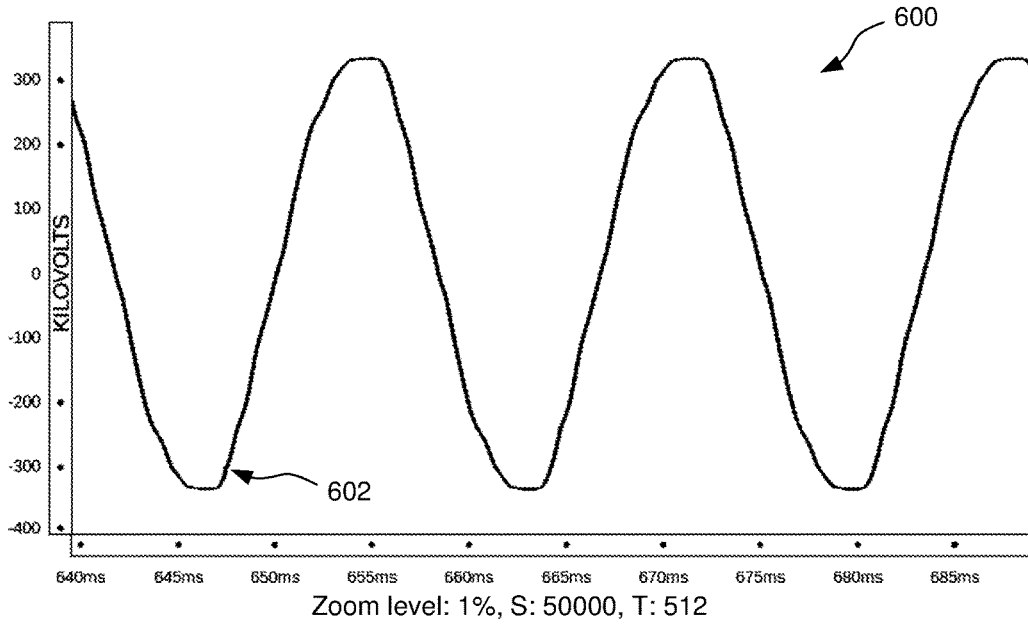

FIGURE 6A

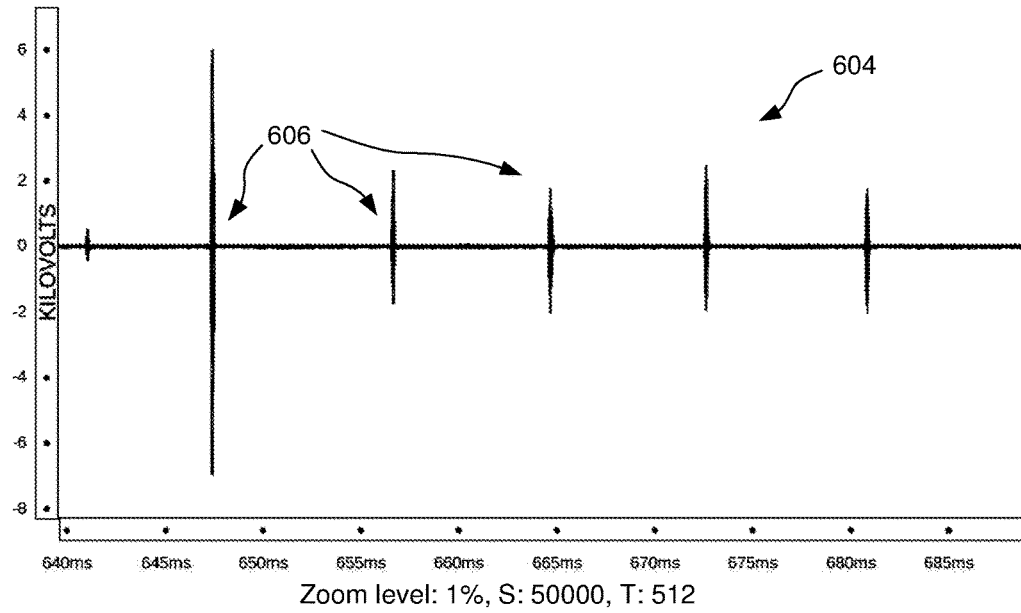

FIGURE 6B

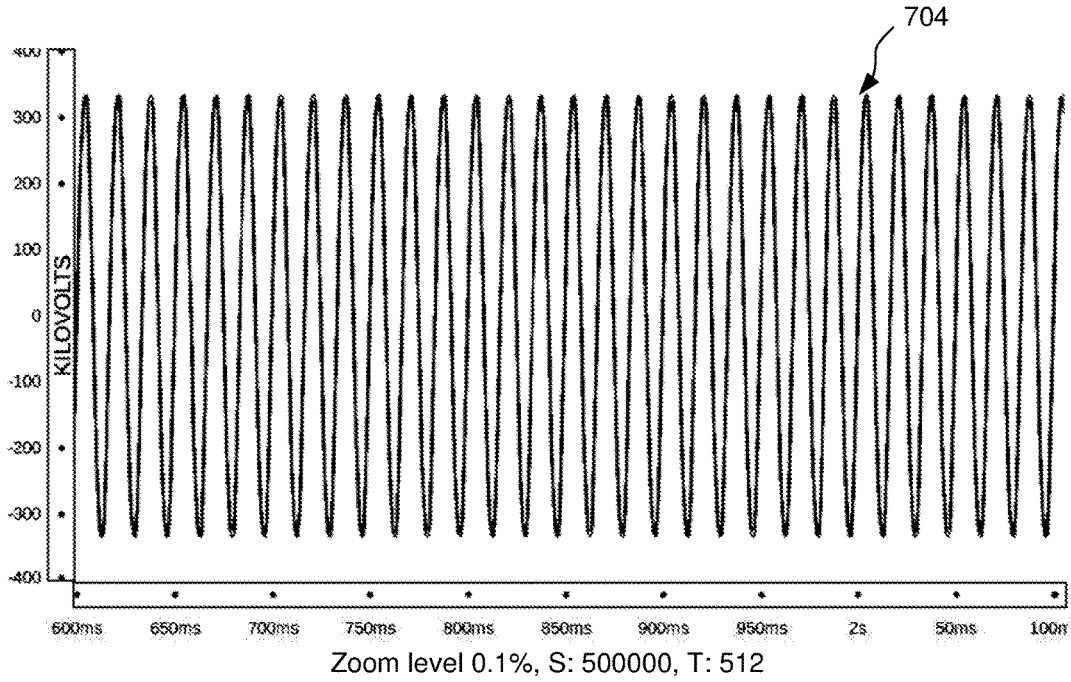

FIGURE 7A

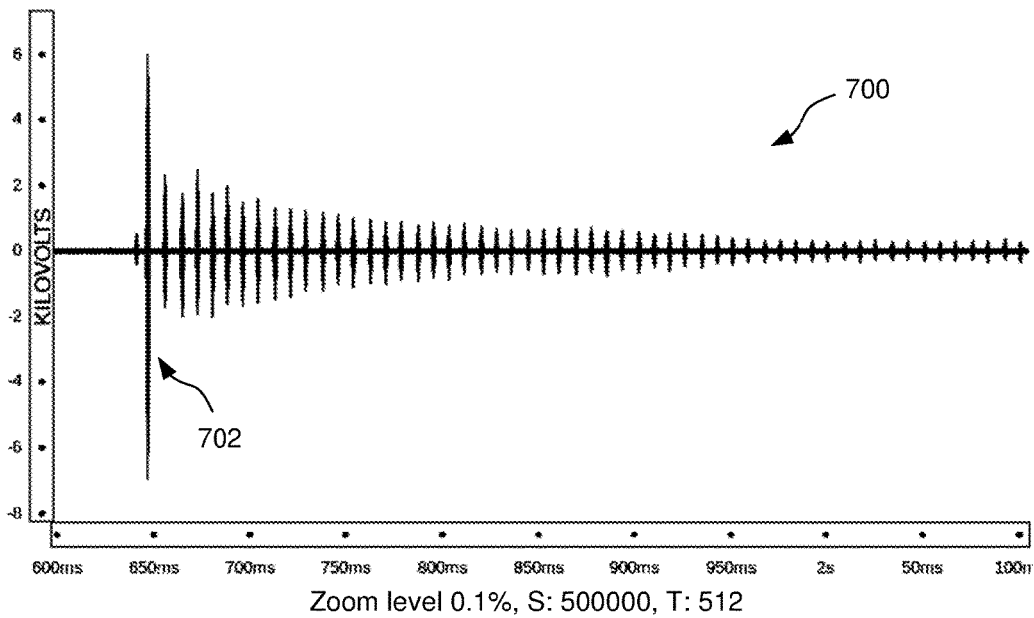

FIGURE 7B

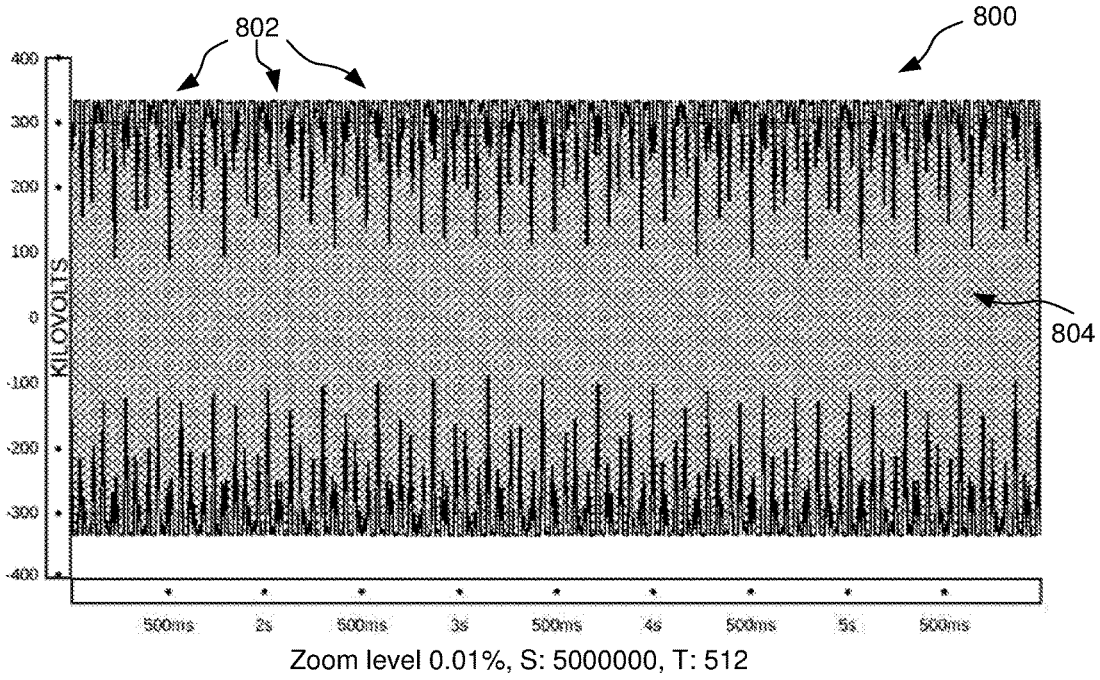

FIGURE 8A

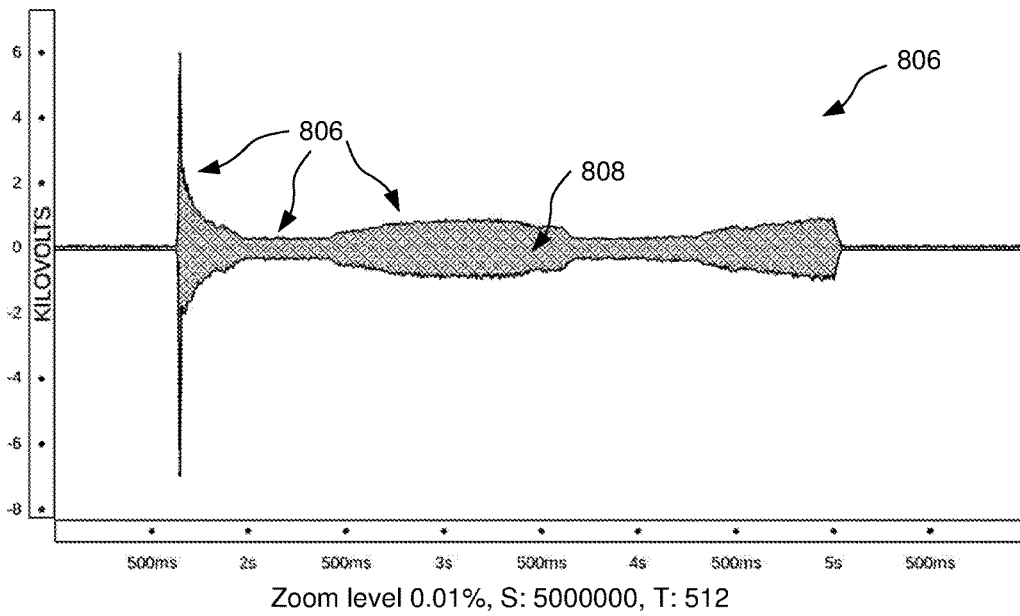

FIGURE 8B

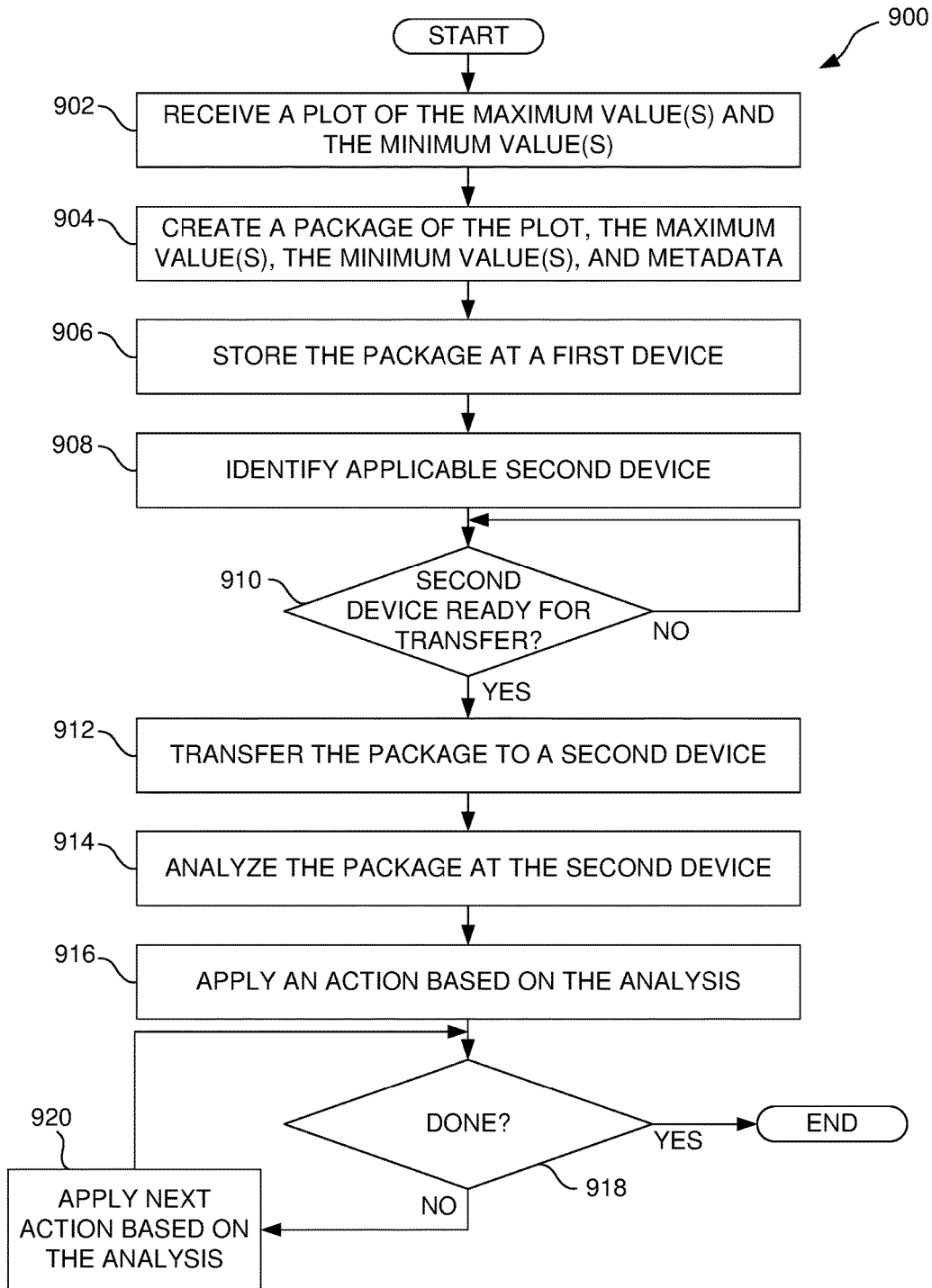

FIGURE 9

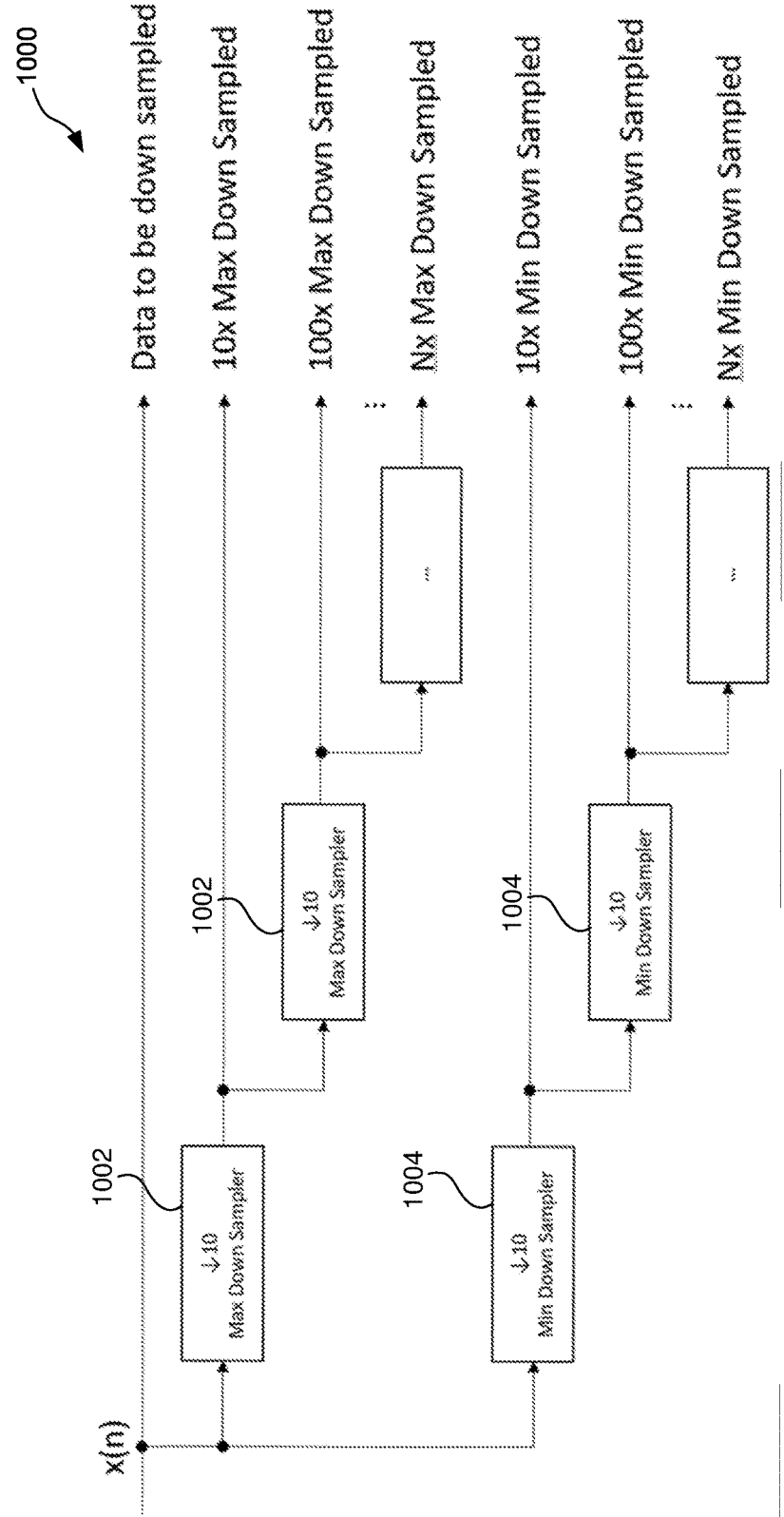

FIGURE 10A

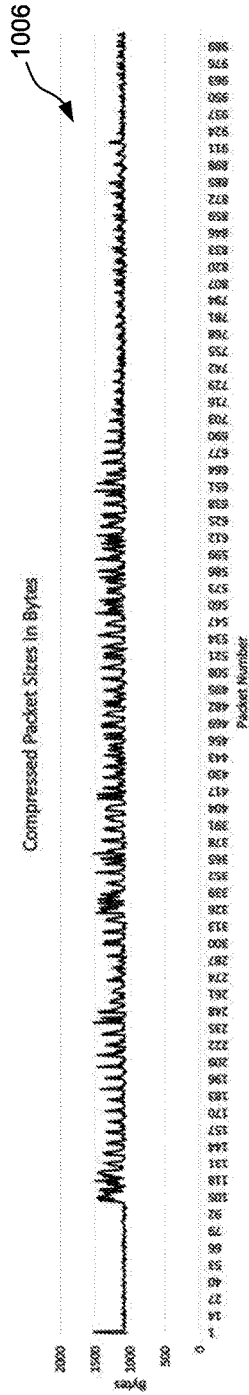

FIGURE 10B

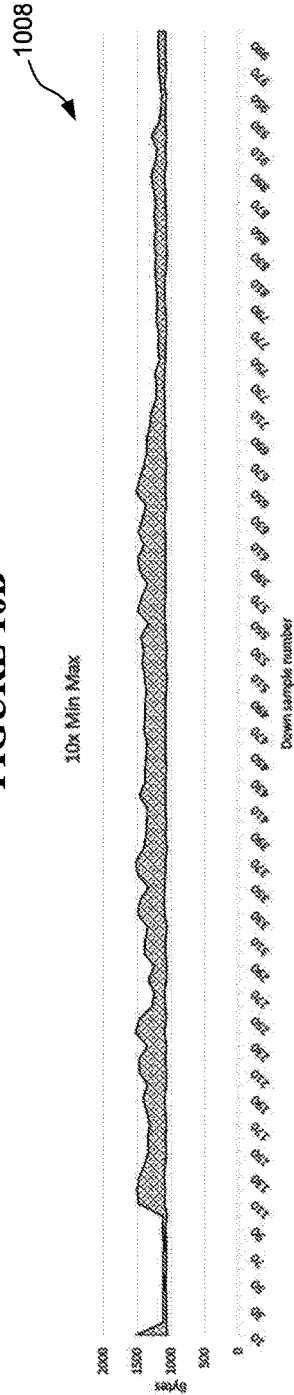

FIGURE 10C

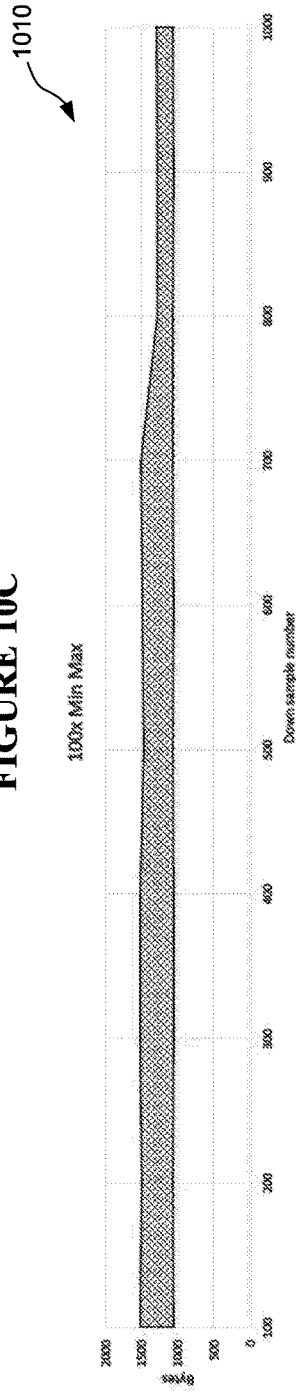

FIGURE 10D

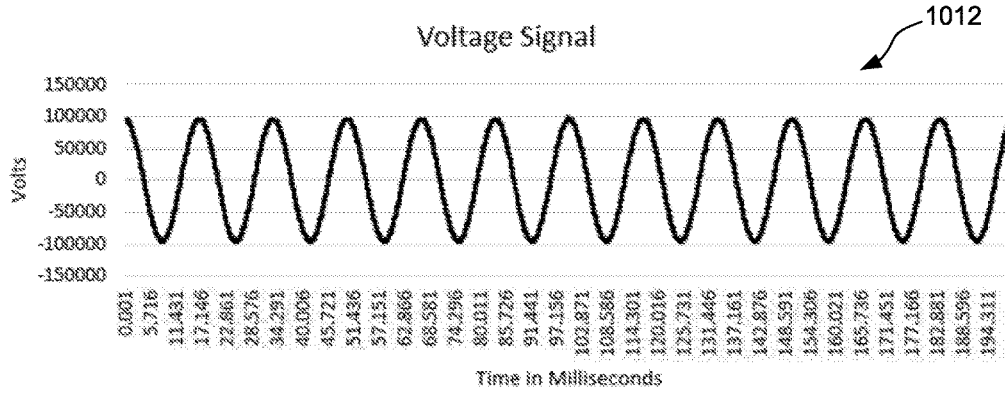

FIGURE 10E

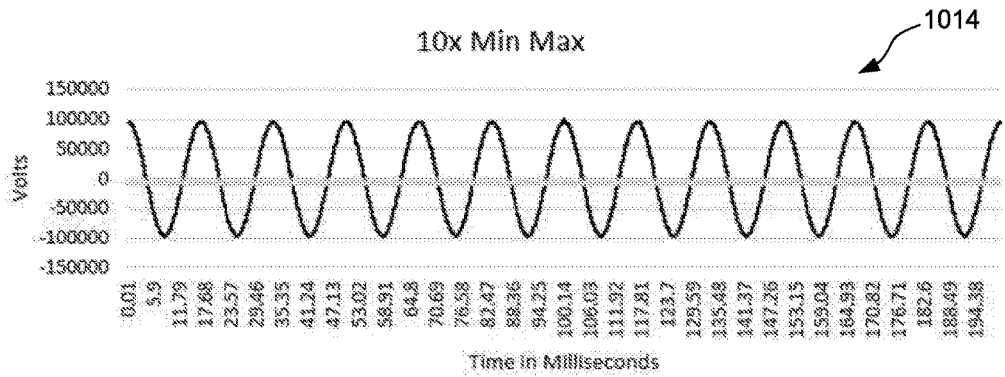

FIGURE 10F

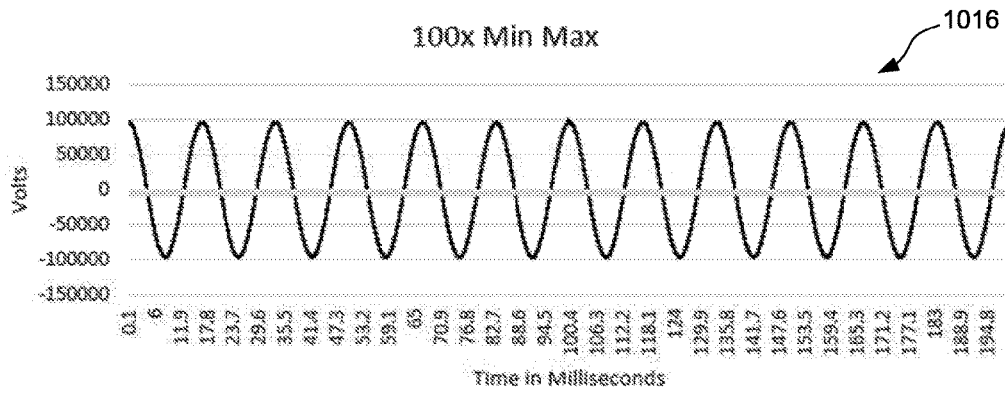

FIGURE 10G

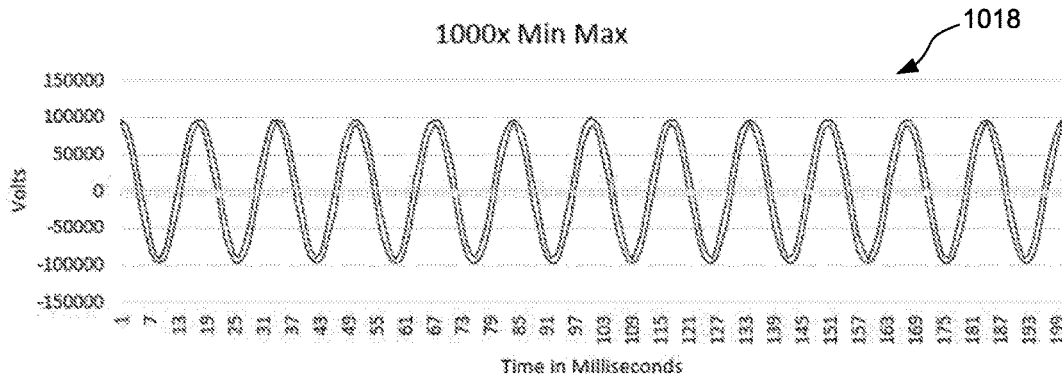

FIGURE 10H

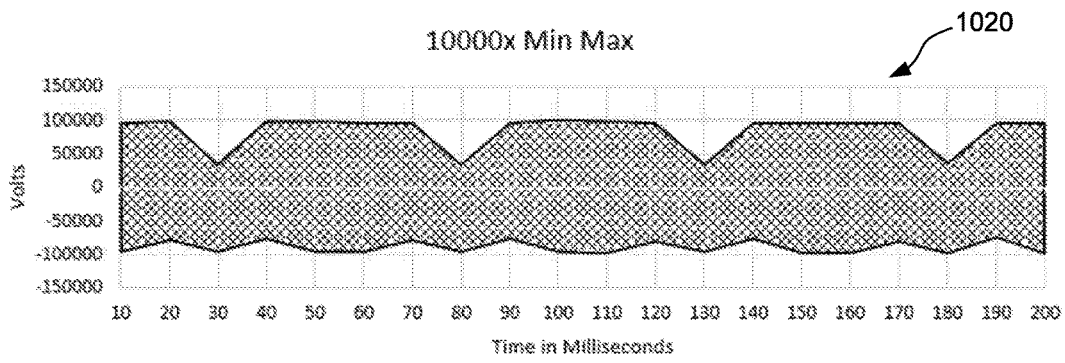

FIGURE 10I

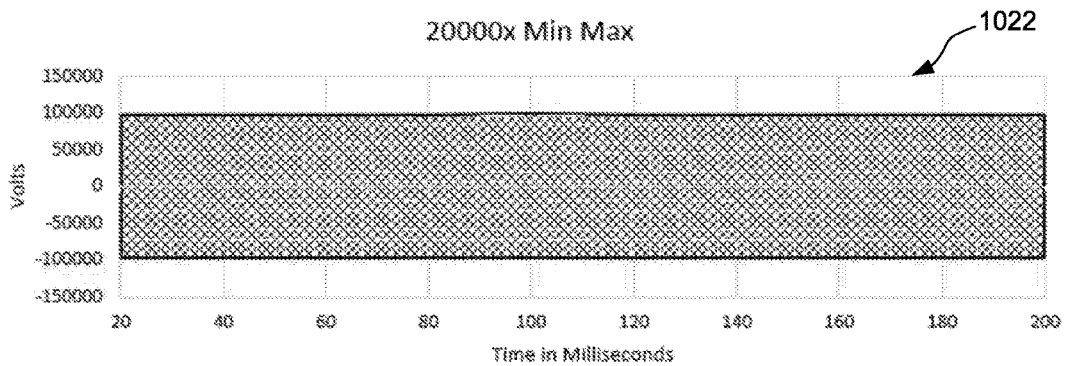

FIGURE 10J

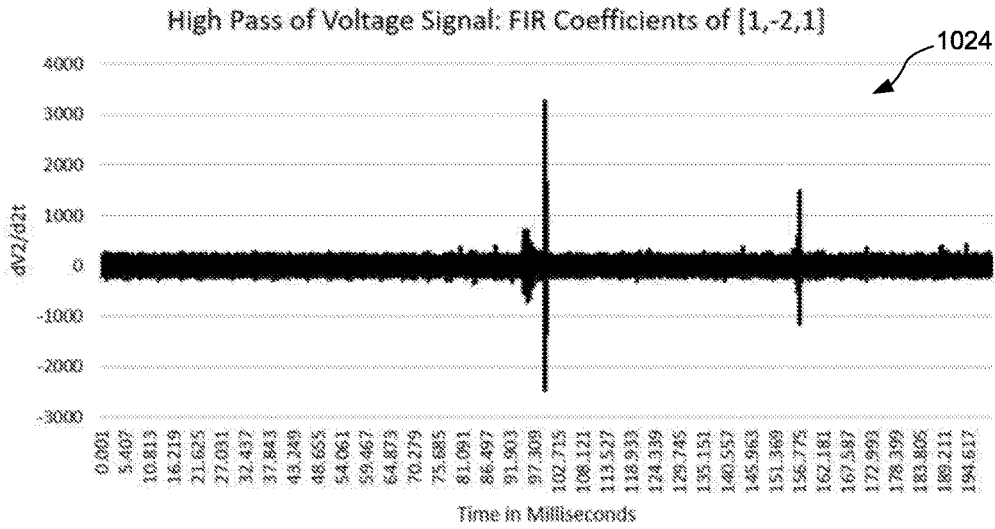

FIGURE 10K

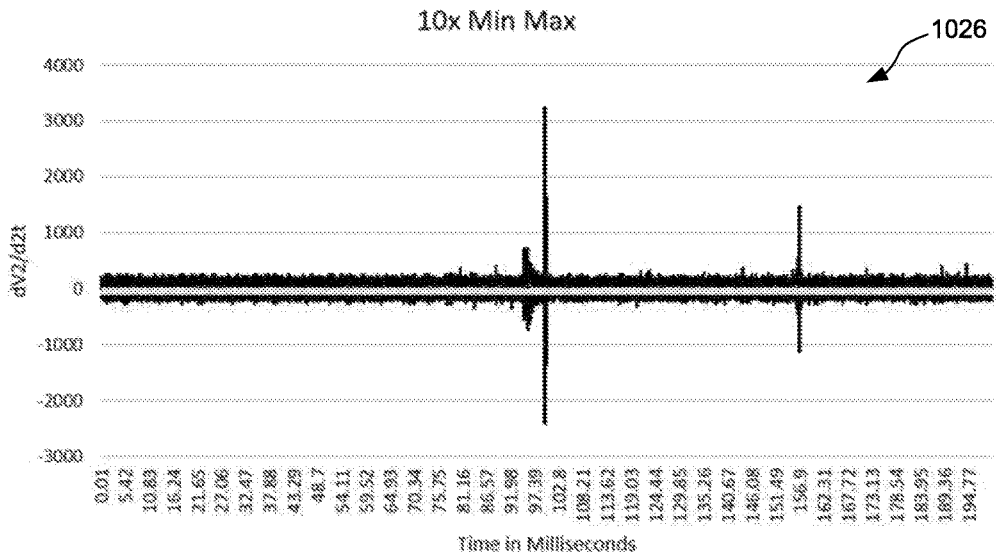

FIGURE 10L

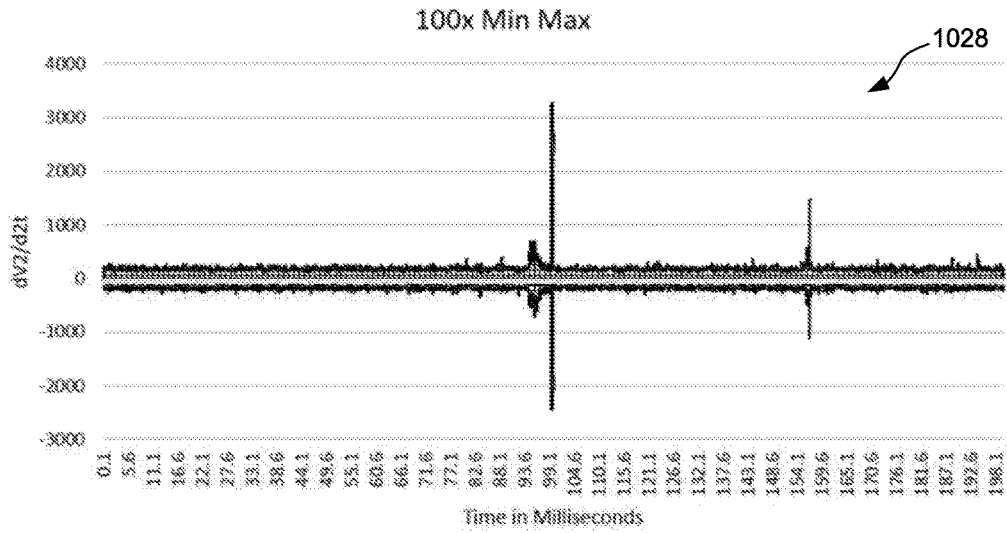

FIGURE 10M

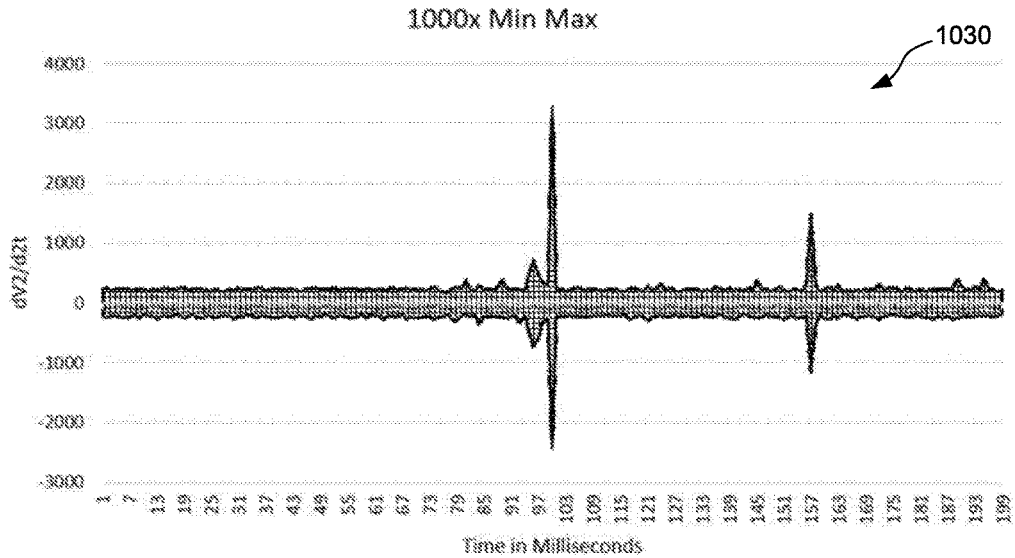

FIGURE 10N

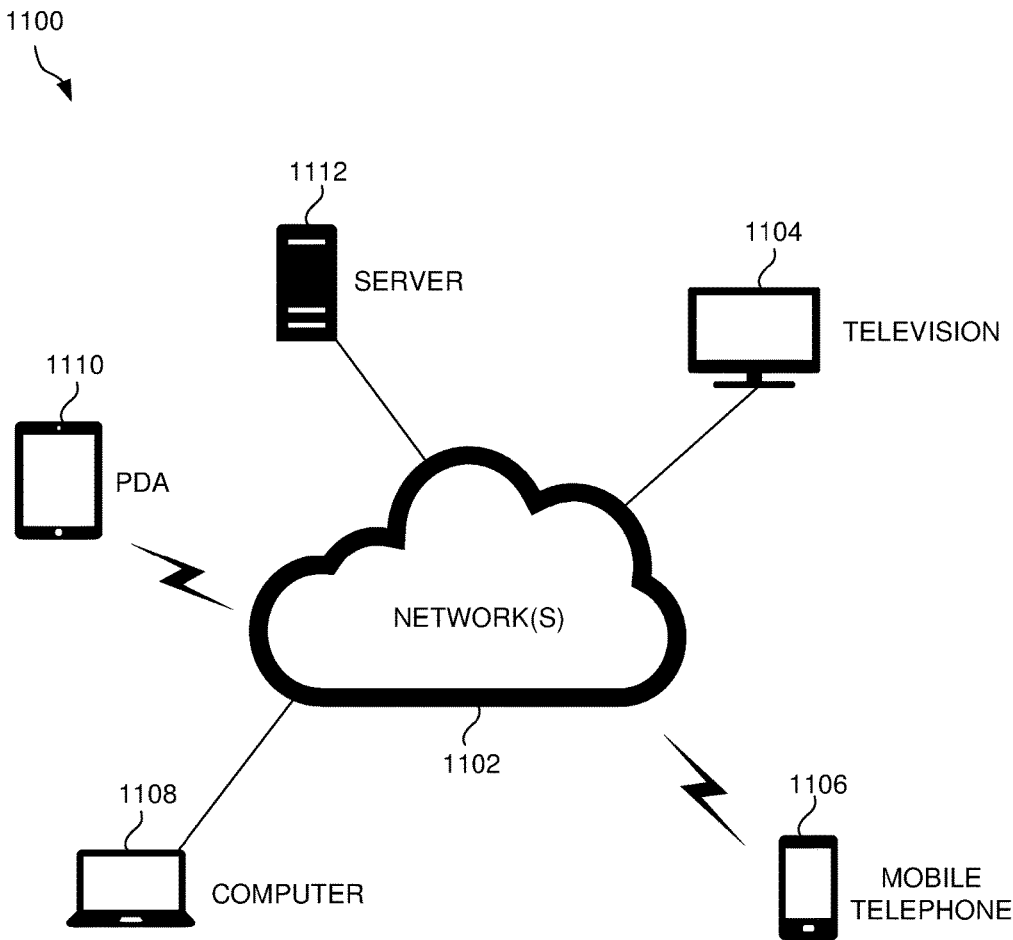

FIGURE 11

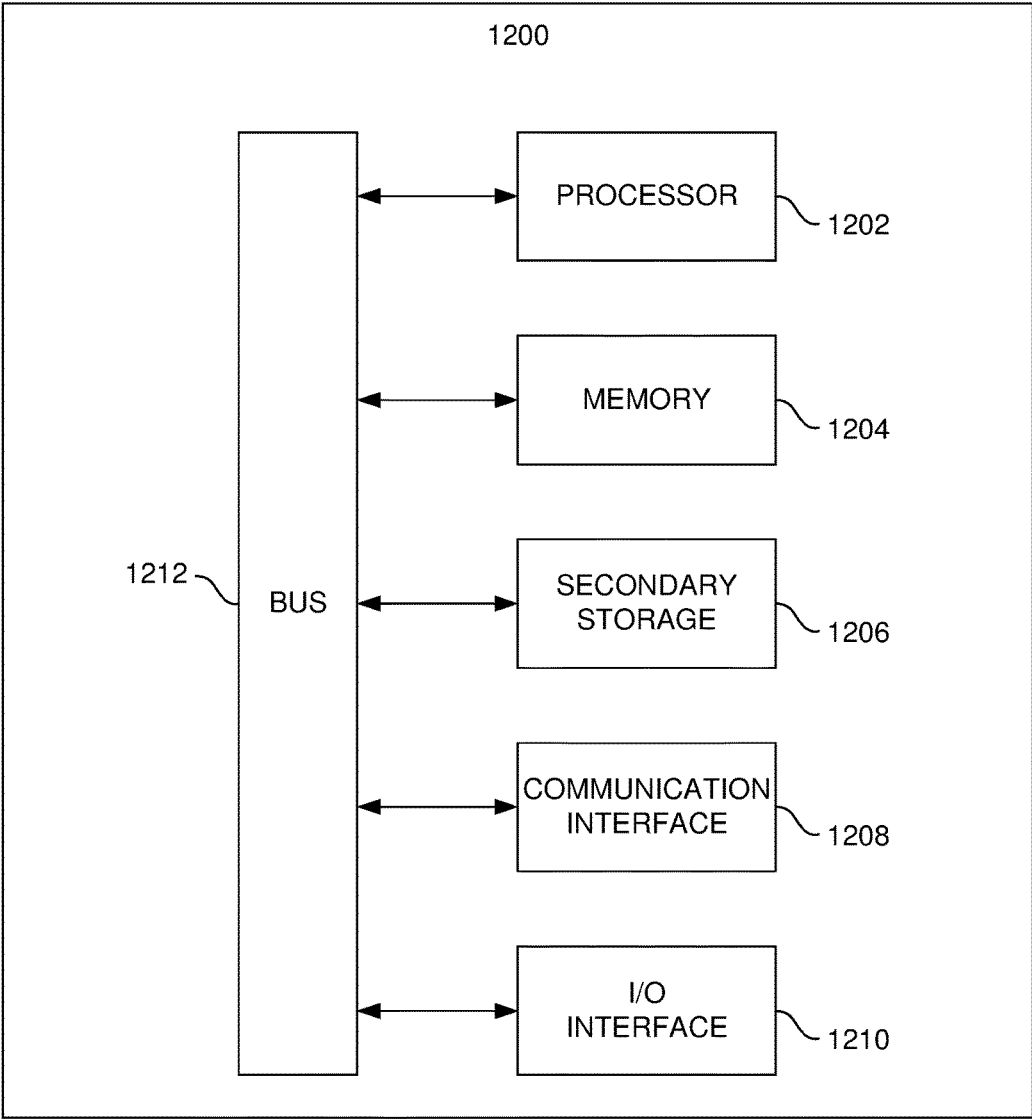

FIGURE 12

GENERATING A REPRESENTATION OF HIGH-FREQUENCY SIGNAL DATA FROM AN ELECTRIC POWER DELIVERY SYSTEM

FIELD OF THE INVENTION

[0001] The present invention relates to presenting signal data, and more particularly to improving the representation of high-frequency signal data.

BACKGROUND

[0002] Currently, analytical data gathered from an electrical power distribution system may be used to understand power generation and diagnose potential problems. Often, such analytical data may include high-frequency data. Displaying high-frequency data, however, may pose a variety of issues, including slow processing time, inaccurate representation of the displayed data, etc. Additionally, such issues are often increased as the data is zoomed out. Current methods to rectify such issues include, for example, a filter applied to the analytical data to remove the high frequency. Such an approach, however, fails to allow for analysis of the high-frequency data. A second approach may include rendering the high-frequency data by applying an alias, resulting in the high-frequency data being displayed as a lower-frequency signal. However, this second approach may cause an inaccurate representation of the high-frequency data.

[0003] There is thus a need for addressing these and/or other issues associated with the prior art.

SUMMARY

[0004] A system, method, and computer program product are provided for representation of signal data. In use, input data is received, wherein the input data is of a first width. Next, the input data is processed to manage display of the input data, where specifically the input data is divided into one or more segments based on first criteria including the first width, and from each segment of the one or more segments, a maximum value is identified and a minimum value is identified. Still yet, the input data is transformed to a visualizable representation of the input data, the visualizable representation of the input data including a plot of the maximum value and the minimum value for each segment of the one or more segments. Additionally, the plot is displayed.

[0005] In a first embodiment, the plot further may include a shaded region between the maximum value and the minimum value for each segment of the one or more segments. Additionally, an overlay may be displayed over the plot. For example, the overlay may include one of a median value of each segment of the one or more segments or a filtered sampled value, the overlay being displayed in a different color than a color of the shaded region.

[0006] In a second embodiment (which may or may not be combined with the first embodiment), the input data may be filtered prior to identifying the maximum value or the minimum value. Additionally, the width of the input data may be based on a size of a window, and the first criteria may include a width of a segment of the one or more segments, wherein the width of the segment is based on a time interval associated with the maximum value or the minimum value.

[0007] In a third embodiment (which may or may not be combined with the first and/or second embodiment), the first criteria may include at least one of a pixel resolution of a

window, a zoom factor (or a plurality of zoom factors), a width associated with the maximum value, a width associated with the minimum value, and an error factor associated with the input data. For example, the first criteria may include the error factor that is an identified signal disturbance, and wherein the plot presents the identified signal disturbance. Additionally, the first criteria may include preset optimal settings with a preconfigured zoom level.

[0008] In a fourth embodiment (which may or may not be combined with the first, second and/or third embodiment), the width of a segment may be based on one of natural numbers or real numbers. Further, a pre-identification of a pre-maximum value and a pre-minimum value may be identified for use with the first criteria.

[0009] In a fifth embodiment (which may or may not be combined with the first, second, third and/or fourth embodiment), each of the maximum value and the minimum value may be recorded as a vector.

[0010] In a sixth embodiment (which may or may not be combined with the first, second, third, fourth, and/or fifth embodiment), the processing of the input data may include receiving a maximum value input and a minimum value input, where the maximum value input may be used to identify the maximum value, and the minimum value input may be used to identify the minimum value. As an option, a width of the maximum value input may differ from a width of the maximum value, and a width of the minimum value input may differ from a width of the minimum value.

[0011] In a seventh embodiment (which may or may not be combined with the first, second, third, fourth, fifth, and/or sixth embodiment), the plot may be sent to a downstream device. Additionally, the plot may be saved with raw data based on the input data, wherein the raw data may include, at a minimum, the maximum value and the minimum value.

[0012] To this end, in some optional embodiments, one or more of the foregoing features of the aforementioned system, computer program, and/or method may result in improved representation of high-frequency signal data. It should be noted that the aforementioned potential advantages are set forth for illustrative purposes only and should not be construed as limiting in any manner.

BRIEF DESCRIPTION OF THE DRAWINGS

[0013] FIG. 1 illustrates a method for generating a representation of high-frequency signal data, in accordance with one embodiment.

[0014] FIG. 2 illustrates a diagram of an electric power delivery system, in accordance with one embodiment.

[0015] FIG. 3 illustrates a method for generating a representation of high-frequency signal data, in accordance with one embodiment.

[0016] FIG. 4A illustrates a plot showing exemplary data with an unfiltered 60 Hz fundamental signal at zoom level 100%, S value of 512, and T value of 512, in accordance with one embodiment.

[0017] FIG. 4B illustrates a plot showing exemplary data with a high-pass filtered 60 Hz fundamental signal at zoom level 100%, S value of 512, and T value of 512, in accordance with one embodiment.

[0018] FIG. 5A illustrates a plot showing exemplary data with an unfiltered 60 Hz fundamental signal at zoom level 10%, S value of 5000, and T value of 512, in accordance with one embodiment.

[0019] FIG. 5B illustrates a plot showing exemplary data with a high-pass filtered 60 Hz fundamental signal at zoom level 10%, S value of 5000, and T value of 512, in accordance with one embodiment.

[0020] FIG. 6A illustrates a plot showing exemplary data with an unfiltered 60 Hz fundamental signal at zoom level 1%, S value of 50000, and T value of 512, in accordance with one embodiment.

[0021] FIG. 6B illustrates a plot showing exemplary data with a high-pass filtered 60 Hz fundamental signal at zoom level 1%, S value of 50000, and T value of 512, in accordance with one embodiment.

[0022] FIG. 7A illustrates a plot showing exemplary data with an unfiltered 60 Hz fundamental signal at zoom level 0.1%, S value of 500000, and T value of 512, in accordance with one embodiment.

[0023] FIG. 7B illustrates a plot showing exemplary data with a high-pass filtered 60 Hz fundamental signal at zoom level 0.1%, S value of 500000, and T value of 512, in accordance with one embodiment.

[0024] FIG. 8A illustrates a plot showing exemplary data with an unfiltered 60 Hz fundamental signal at zoom level 0.01%, S value of 5000000, and T value of 512, in accordance with one embodiment.

[0025] FIG. 8B illustrates a plot showing exemplary data with a high-pass filtered 60 Hz fundamental signal at zoom level 0.01%, S value of 5000000, and T value of 512, in accordance with one embodiment.

[0026] FIG. 9 illustrates a method for transferring information for generating a representation of high-frequency signal data, in accordance with one embodiment.

[0027] FIG. 10A illustrates a process for identifying min and max downsampled values, in accordance with one embodiment.

[0028] FIG. 10B illustrates a plot applying the process of FIG. 10A, in accordance with one embodiment.

[0029] FIG. 10C illustrates a plot which is a 10× down-sampling of the plot shown in FIG. 10B, in accordance with one embodiment.

[0030] FIG. 10D illustrates a plot which is a 100× down-sampling of the plot shown in FIG. 10B, in accordance with one embodiment.

[0031] FIG. 10E illustrates a plot of a voltage signal, in accordance with one embodiment.

[0032] FIG. 10F illustrates a plot of a 10× min max downsampled signal of the plot shown in FIG. 10E, in accordance with one embodiment.

[0033] FIG. 10G illustrates a plot of a 100× min max downsampled signal of the plot shown in FIG. 10E, in accordance with one embodiment.

[0034] FIG. 10H illustrates a plot of a 1000× min max downsampled signal of the plot shown in FIG. 10E, in accordance with one embodiment.

[0035] FIG. 10I illustrates a plot of a 10000× min max downsampled signal of the plot shown in FIG. 10E, in accordance with one embodiment.

[0036] FIG. 10J illustrates a plot of a 20000× min max downsampled signal of the plot shown in FIG. 10E, in accordance with one embodiment.

[0037] FIG. 10K illustrates a plot of a high pass filter applied to a voltage signal, in accordance with one embodiment.

[0038] FIG. 10L illustrates a plot of a 10× min max downsampled signal of the plot shown in FIG. 10K, in accordance with one embodiment.

[0039] FIG. 10M illustrates a plot of a 100× min max downsampled signal of the plot shown in FIG. 10K, in accordance with one embodiment.

[0040] FIG. 10N illustrates a plot of a 1000× min max downsampled signal of the plot shown in FIG. 10K, in accordance with one embodiment.

[0041] FIG. 11 illustrates a network architecture, in accordance with one possible embodiment.

[0042] FIG. 12 illustrates an exemplary system, in accordance with one embodiment.

DETAILED DESCRIPTION

[0043] FIG. 1 illustrates a method 100 for generating a representation of high-frequency signal data, in accordance with one embodiment. As shown, in operation 102, input data is received including high-frequency signals, wherein the input data is of a first width. In the context of the present description, the aforementioned input data may include any set of signals (including potentially high-frequency signals) generated by a power distribution system. For example, such signals may be generated by faults, partial discharge activity, equipment operation (e.g., breakers operating, capacitor banks switching, voltage tap changes, etc.).

[0044] Still yet, in the present description, a high-frequency signal may refer to any frequency considered high based on the context from which the signal is obtained. For example, a high-frequency signal relating to speech may be 3 kHz, whereas a high-frequency signal relating to a wireless transmission may be 5 GHz. Even still, a high-frequency signal relating to electric power systems may be in the range of 1 kHz.

[0045] In the present description, the first width may refer to any measurement from side to side of the signals included in the input data. For example, in one possible embodiment, the width may be what is displayed within a window, or may be based on a size of a window in which the signals are displayed.

[0046] The input data is then processed in operation 104 to manage display of the input data, including: dividing the input data into one or more segments based on first criteria including the first width; identifying, from each segment of the one or more segments, a maximum value; and identifying, from each segment of the one or more segments, a minimum value. The first width may be determined based, at least in part, on the first criteria. In various embodiments, the first criteria may include at least one of a pixel resolution of a window, a zoom factor (or a plurality of zoom factors), a width associated with a maximum value, a width associated with a minimum value, or an error factor associated with the input data. Also, in the context of the present description, the first criteria may include the error factor that is an identified signal disturbance. Further, the first criteria may include preset optimal settings with a preconfigured zoom level. Specifically, such optimal settings may include pre-viewing actions and current-viewing actions. Pre-viewing actions may include applying various settings (e.g. zoom level 1, zoom level 2, etc.) to the input data such that results are generated before they are requested or viewed. Current-viewing actions may include applying various settings (e.g. window size X, zoom level Y, minimum value width Z, etc.) to be displayed. In one embodiment, such current-viewing

actions may be applied when a user interface (e.g. showing the plot, as will be elaborated upon later in greater detail) is initially requested, or may be applied as manually requested (e.g. based on a default setting or preconfigured setting to be applied as desired, etc.).

[0047] Thus, the first criteria may be used to modify a display (used to present the representation of the input data), configure predetermined settings, and/or personalize the interaction with the plot in some manner. In one embodiment, the width of the segment of the one or more segments may be based on one of natural numbers or real numbers. Further, a pre-identification of a pre-maximum value and a pre-minimum value may be identified for use with the first criteria.

[0048] In the context of the present description, the one or more segments may include any grouping of the input data. For example, the input data (i.e. signals) may be divided into a number of bins (e.g. frequency bins) equal to the width of an output (e.g. minimum value or maximum value). In one embodiment, the width of a segment of the one or more segments may be equal to or less than the first width of the input data.

[0049] In the context of the present description, the maximum value may correspond with a maximum point of a segment of the input data (e.g. frequency signal) and the minimum value may correspond with a minimum point of a segment of the input data (e.g. frequency signal). In one embodiment, the first criteria may include a width of a segment of the one or more segments, wherein the width of the segment is based on a time interval associated with the maximum value or the minimum value. Also, in the context of the present description, each of the maximum value and the minimum value may be recorded as a vector. Further, the input data may be filtered prior to identifying the maximum value or the minimum value.

[0050] In one embodiment, receiving the input data may include receiving a maximum value input and a minimum value input, where the maximum value input may be used to identify the maximum value, and the minimum value input may be used to identify the minimum value. As an option, a width of the maximum value input may differ from a width of the maximum value, and a width of the minimum value input may differ from a width of the minimum value.

[0051] With continuing reference to FIG. 1, in operation 106, the input data is transformed to a visualizable representation of the high-frequency signals, the visualizable representation of the high-frequency signals including a plot of the maximum value and the minimum value for each segment of the one or more segments. In the context of the present description, transforming the input data to a visualizable representation may include receiving the raw input data, extracting points of interest (e.g. maximum value, minimum value, etc.) and then constructing a representation of the input data based on such points of interest. In this manner, only a fraction of the raw input data (in the form of the maximum value and the minimum value) may be used to construct the representation.

[0052] To this end, in operation 108, a plot may be displayed. In one embodiment, the plot may include a shaded region between the maximum value and the minimum value for each segment of the one or more segments. Additionally, an overlay may be displayed over the plot. For example, the overlay may include one of a median value of each segment of the one or more segments or a filtered

sampled value, the overlay being displayed in a different color than a color of the shaded region.

[0053] The plot may present the identified signal disturbance. Of course, it is appreciated that any signal deviation or anomaly may be additionally displayed.

[0054] Still yet, the plot may be saved. To this end, the saved plot may require less data (in comparison to the input data) and may preserve raw data (e.g. maximum value, minimum value, etc.) of the input data. Additionally, the plot may be saved with raw data based on the input data, wherein the raw data may include, at a minimum, the maximum value and the minimum value. Further, the plot may be sent to a downstream device in an efficient manner (via reduced data for transmission and display).

[0055] FIG. 2 illustrates a diagram of an electric power delivery system 200, in accordance with one embodiment. As an option, the system 200 may be implemented in the context of any one or more of the embodiments set forth in any previous and/or subsequent figure(s) and/or description thereof. However, it is to be appreciated that the system 200 may be implemented in the context of any desired environment. In particular, the system 200 may provide one example where high-frequency signal data may be obtained, as described in relation to method 100.

[0056] As shown, system 200 includes a simplified example of an electric power delivery system. Such a system 200 may include generator 230 which may be monitored by an intelligent electronic device (IED) (e.g. IED 164), and may generate electric power. Generator 230 may be connected to bus 219 via a circuit breaker 211, which may be controlled using IED 266, and via transformer 214 (which may be a step-up transformer for transforming the voltage of the electric power from generator 230 to a higher voltage suitable for an electric power transmission system).

[0057] Bus 219 and bus 223 may be connected via transmission lines 220a and 220b operating at transmission-level voltages. Transmission line 220b may include circuit breakers 245 and 251 monitored and controlled by IEDs 269 and 254. Transmission line 220a may include circuit breakers 244 and 250 monitored and controlled by IEDs 256 and 260. Transmission line 220b may be monitored by an IED 252 which may be capable of providing differential protection. Similarly, transmission line 220a may be monitored and controlled by IED 258 which may be capable of providing differential protection. Alternatively, transmission lines 220a and 220b may be monitored and/or controlled using multiple IEDs such as one IED at each end of the transmission lines capable of performing differential protection using communication therebetween.

[0058] Bus 223 may be connected to a distribution bus 225 using a step-down transformer 224 that may be capable of stepping down the voltage from the transmission bus 223 to distribution levels. Bus 225 may be monitored and/or controlled using IED 268, and may provide electric power to load 295 (where the voltage may be stepped further down using a transformer). A further transformer 292 and circuit breaker 291 may connect transmission bus 225 to generator 290. Circuit breaker 291 may be monitored and controlled via IED 293. Generator 290 may be a distributed generator such as a solar-power generator, wind turbine, natural gas electric generator, diesel generator, or the like.

[0059] Although not separately illustrated, the various IEDs may obtain electric power information from the monitored equipment in system 200 using potential transformers

(PTs, for voltage measurements), current transformers (CTs, for current measurements), etc. The PTs and CTs may include any device capable of providing outputs that can be used by the IEDs to make potential and current measurements, and may include traditional PTs and CTs, optical PTs and CTs, Rogowski coils, hall-effect sensors, etc. Furthermore, although not separately illustrated, each IED may include access to a common time source. The common time source may be distributed via a communications network (using, for example, IEEE-1588 protocol, NTP protocol, or the like), or obtained locally at each IED. The common time source may be a universal time, such as that delivered using global positioning system (GPS) satellites, WWVB, WWV, etc. A common time may be used to time-synchronize measurements of the electric power system, and in the calculation of synchrophasors. Measurements may be paired with a time stamp or time tag indicating a time at which the measurement was made. Accordingly, phasors calculated by the IEDs may include a time stamp indicating a time at which the measurement was made.

[0060] IEDs in system **200** may be configured to communicate phasor and/or synchrophasor information to a central unit such as Phasor Data Concentrator (PDC) **270**. The PDC **270** may be capable of receiving and storing the phasor and/or synchrophasor or other gathered or calculated power system information (hereinafter “PMU data”). The PDC **270** may be in communication with a mass storage device **284** capable of storing the PMU data received by PDC **270**.

[0061] PDC **270** may also be in communication with a number of other devices or systems that may consume PMU data. Such devices or systems may include, for example, a Wide Area Control and Situational Awareness (WCSA) System **280**, Supervisory Control and Data Acquisition (SCADA) System **282**, local Human-Machine Interface (HMI) **286**, or automation controller **272**. PDC **270** may further include a time input, which may receive a time signal from a common time source **288**.

[0062] In relation to method **100** specifically, one or more elements in system **200** may be used as a basis for input data (e.g. signal data). For example, one or more IEDs (e.g. **252**, **254**, **256**, **258**, **260**, **264**, **266**, **268**, **269**, **293**, etc.) may be used to collect or gather information relating to signal data of the power distribution system. Such IEDs may collect the signal data from any component (e.g. conductor, transformer, converter, bus, etc.) of the power distribution system. Additionally, in one embodiment, a database associated with the one or more IEDs may be physically separated or located remotely from the one or more IEDs.

[0063] More illustrative information will now be set forth regarding various optional architectures and uses in which the foregoing method may or may not be implemented, per the desires of the user. It should be strongly noted that the following information is set forth for illustrative purposes and should not be construed as limiting in any manner. Any of the following features may be optionally incorporated with or without the exclusion of other features described.

[0064] FIG. 3 illustrates a method **300** for generating a representation of high-frequency signal data, in accordance with one embodiment. As an option, the method **300** may be implemented in the context of any one or more of the embodiments set forth in any previous and/or subsequent figure(s) and/or description thereof. Of course, however, the method **300** may be implemented in the context of any

desired environment. Further, the aforementioned definitions may equally apply to the description below.

[0065] In one embodiment, method **300** may represent one exemplary embodiment for generating a representation of high-frequency signal data. In particular, method **300** may represent one exemplary algorithm used to generate a representation of high-frequency signal data. As shown, in operation **302**, a set of input data $x[k]$ of length S is received. In one embodiment, the length S may correspond with the first width (see operation **102**). Next, in operations **304** and **306**, two sets of output data are defined, where operation **304** sets a first output data as $x_{\min}[k]$ with length T , and operation **306** sets a second output data as $x_{\max}[k]$ with length T . In method **300**, operations **302**, **304**, and **306** may represent inference rules (i.e. given clauses, etc.) used in the algorithm for visualizing high-frequency signal data.

[0066] Per operation **308**, input data $x[k]$ is divided into T bins of S/T width. In the context of the present description, a bin may include a segment of a grouping of the input data. In one embodiment, the number of bins may equal the length of each output (e.g. $x_{\min}[k]$, $x_{\max}[k]$, etc.). To that end, per decision **310**, it is determined whether each bin of the T bins satisfies $0 \leq K < T$. In one embodiment, T may be the width of a minimum value or maximum value. Further, a quantity of samples in each bin of a plurality of bins may equal the first width divided by a number of the one or more bins. For example, if length S was 24, and length T was 8, that would correspond with each bin having three (3) items (i.e. T bins of S/T width). Thus, in one embodiment, if a bin includes three (3) items, then one item would be selected from the bin for $x_{\min}[k]$, another one item would be selected from the bin for $x_{\max}[k]$, and the remaining one item would not be used. While the subject matter is being described in the foregoing context, it is not meant to be limiting as those of skill in the art will appreciate that various of the acts and operations (including different sizes of length S and length T) described hereinafter may also be implemented. Still yet, length S may be greater or equal to length T , and the result for T bins may include T items in each output (e.g. per T bins of S/T width).

[0067] Additionally, in the context of the present description, when downsampling data, T may represent the amount of underlying raw data that is available for a given requested range, and S may represent the number of data points that will be used to represent the underlying data to the user or application. As an example, time series data may be sampled at 20 thousand points per second, and a user or application may request 13 seconds worth of data to be represented with 500 samples. In such an example, T may equal $20000 \times 13 = 160000$ (underlying raw data), and S may equal 500 (number of data points). Each bin may be 320 samples wide and may result in a single Min and single Max per bin. In one embodiment, each bin may contain (but is not required to contain) an integer number of points.

[0068] If decision **310** results in a “no”, the method returns to operation **304**. Conversely, if decision **310** results in a “yes”, the method proceeds on to operation **312** where, for each bin, the maximum value $x_{\max}[k]$ and the minimum value $x_{\min}[k]$ are identified. In one embodiment, the $x_{\max}[k]$ and $x_{\min}[k]$ may be calculated (see further discussion below relating to FIG. 10A). Additionally, the $x[k]$ data may be filtered prior to calculating the $x_{\min}[k]$ and $x_{\max}[k]$. For each bin, per operation **314**, the maximum value $x_{\max}[k]$ and the minimum value $x_{\min}[k]$ are

stored. For example, the maximum value $x_{\max}[k]$ and the minimum value $x_{\min}[k]$ may be stored in a database attached directly to an IED (or other device collecting signal data). In an alternative arrangement, the database may be physically separated or located remotely (e.g. via the cloud). Additionally, each of the maximum value $x_{\max}[k]$ and the minimum value $x_{\min}[k]$ may be stored without time limitations (without end), or with a predetermined time constraint (e.g. 30 days, etc.).

[0069] Still yet, per operation **316**, for each bin, the $x_{\min}[k]$ and the $x_{\max}[k]$ are plotted. In one embodiment, multiple plots may be displayed simultaneously (i.e. if more than one bin is plotted on a single chart, several $x_{\min}[k]$ points and several $x_{\max}[k]$ points may be plotted). Additionally, where multiple plots are displayed, each bin may operate independent of any of the other displayed bins. For example, if input data associated with a first displayed bin is updated, the plot associated with the first displayed bin may be updated as well, wherein such updates are independent of any other displayed bins.

[0070] Lastly, the area between each plotted $x_{\min}[k]$ and $x_{\max}[k]$ is shaded per operation **318**. In one embodiment, the shading may be of the same color as the plotted $x_{\min}[k]$ value and the plotted $x_{\max}[k]$ value. Conversely, the shading may be of a different color or pattern from the plotted $x_{\min}[k]$ value and the plotted $x_{\max}[k]$ value.

[0071] In this manner, input signal data may be downsampled by computing a minimum and maximum value for each downsample window, and a chart may be constructed showing the minimum value plot and the maximum value plot.

[0072] FIG. 4A illustrates a plot **400** showing exemplary data with an unfiltered 60 Hz fundamental signal at zoom level 100%, S value of 512, and T value of 512, in accordance with one embodiment. As an option, the plot **400** may be implemented in the context of any one or more of the embodiments set forth in any previous and/or subsequent figure(s) and/or description thereof. However, it is to be appreciated that the plot **400** may be implemented in the context of any desired environment.

[0073] As shown in plot **400**, at zoom level 100%, a disturbance **402** may be readily observed. Note that the disturbance **402** corresponds with high-frequency data. Additionally, at a zoom level of 100%, note that no shading occurs because all of the displayed data points correspond with all of the raw input data. This is verified by a S value of 512, and a T value of 512, which would correspond with only 1 bin. As such, because a maximum value and a minimum value have not been determined (based on the values of S and T), shading between a maximum value and a minimum value is not found.

[0074] FIG. 4B illustrates a plot **404** showing exemplary data with a high-pass filtered 60 Hz fundamental signal at zoom level 100%, S value of 512, and T value of 512, in accordance with one embodiment. As an option, the plot **404** may be implemented in the context of any one or more of the embodiments set forth in any previous and/or subsequent figure(s) and/or description thereof. However, it is to be appreciated that the plot **404** may be implemented in the context of any desired environment.

[0075] Similar to plot **400**, plot **404** is shown at zoom level 100% but, in comparison to plot **400** which showed an unfiltered signal, plot **404** shows a high-pass filtered signal. Note that the disturbance **406** correspond with high-fre-

quency data. Additionally, as described hereinabove in relation to plot **400**, no shading is shown for plot **404** because all of the displayed data points correspond with all of the raw input data.

[0076] FIG. 5A illustrates a plot **500** showing exemplary data with an unfiltered 60 Hz fundamental signal at zoom level 10%, S value of 5000, and T value of 512, in accordance with one embodiment. As an option, the plot **500** may be implemented in the context of any one or more of the embodiments set forth in any previous and/or subsequent figure(s) and/or description thereof. However, it is to be appreciated that the plot **500** may be implemented in the context of any desired environment.

[0077] As shown in plot **500**, at zoom level 10%, a disturbance **502** may be readily observed. Note that the disturbance **502** corresponds with high-frequency data. Additionally, at a zoom level of 10%, the input data is separated into bins, a maximum value is identified, a minimum value is identified, and shading between the maximum value and the minimum value is also shown.

[0078] FIG. 5B illustrates a plot **504** showing exemplary data with a high-pass filtered 60 Hz fundamental signal at zoom level 10%, S value of 5000, and T value of 512, in accordance with one embodiment. As an option, the plot **504** may be implemented in the context of any one or more of the embodiments set forth in any previous and/or subsequent figure(s) and/or description thereof. However, it is to be appreciated that the plot **504** may be implemented in the context of any desired environment.

[0079] Similar to plot **500**, plot **504** is shown at zoom level 10% but, in comparison to plot **500** which showed an unfiltered signal, plot **504** shows a high-pass filtered signal. Note that the disturbance **506** correspond with high-frequency data. Additionally, as described hereinabove in relation to plot **500**, shading is shown (and in fact more easily observed than in plot **500**) between the identified maximum value and the identified minimum value.

[0080] FIG. 6A illustrates a plot **600** showing exemplary data with an unfiltered 60 Hz fundamental signal at zoom level 1%, S value of 50000, and T value of 512, in accordance with one embodiment. As an option, the plot **600** may be implemented in the context of any one or more of the embodiments set forth in any previous and/or subsequent figure(s) and/or description thereof. However, it is to be appreciated that the plot **600** may be implemented in the context of any desired environment.

[0081] As shown in plot **600**, at zoom level 1%, a slight disturbance **602** may be observed. Such disturbance **602** is not readily or easily observed for the unfiltered fundamental signal. However, plot **604** (described below) more easily displays the disturbance.

[0082] As an example, disturbances may be more visible in plot **604** (a min max downsampled chart) because of a time dilation of the min max data. In other words, a point of disturbance may be maintained during downsampling, but if the point of disturbance lasts for only 10 samples, and the data is downsampled by a factor of 1000, then the smallest temporal change that can be represented may be that of 1000 samples.

[0083] Further, as a second illustration, disturbances may be more visible in plot **604** (a min max downsampled chart) due to downsampling methods. For example, a low pass filter may be first applied to the data prior to decimation, and such low pass filter may remove any high-frequency

changes and lessen step changes (which may be broad frequency). If filtering is first applied (e.g. to isolate high-frequency changes), then the largest changes may be preserved by Min Max downsampling.

[0084] FIG. 6B illustrates a plot **604** showing exemplary data with a high-pass filtered 60 Hz fundamental signal at zoom level 1%, S value of 50000, and T value of 512, in accordance with one embodiment. As an option, the plot **604** may be implemented in the context of any one or more of the embodiments set forth in any previous and/or subsequent figure(s) and/or description thereof. However, it is to be appreciated that the plot **604** may be implemented in the context of any desired environment.

[0085] Similar to plot **600**, plot **604** is shown at zoom level 1% but, in comparison to plot **600** which showed an unfiltered signal, plot **604** shows a high-pass filtered signal. Note that the disturbances **606** correspond with high-frequency data. Each disturbance of disturbances **606** may represent activity at the top and bottom of voltage waveforms. Additionally, such disturbances **606** are more readily and easily observed, especially compared to the unfiltered disturbance **602**.

[0086] FIG. 7A illustrates a plot **704** showing exemplary data with unfiltered 60 Hz fundamental signal at zoom level 0.1%, S value of 500000, and T value of 512, in accordance with one embodiment. As an option, the plot **704** may be implemented in the context of any one or more of the embodiments set forth in any previous and/or subsequent figure(s) and/or description thereof. However, it is to be appreciated that the plot **704** may be implemented in the context of any desired environment.

[0087] As shown in plot **700**, at zoom level 0.1%, a disturbance **702** may be observed. In contrast to plot **600** which only slightly showed a disturbance in comparison to plot **604**, the disturbance **702** on plot **700** is more readily or easily observed in comparison to plot **704**.

[0088] FIG. 7B illustrates a plot **700** showing exemplary data with a high-pass filtered 60 Hz fundamental signal at zoom level 0.1%, S value of 500000, and T value of 512, in accordance with one embodiment. As an option, the plot **700** may be implemented in the context of any one or more of the embodiments set forth in any previous and/or subsequent figure(s) and/or description thereof. However, it is to be appreciated that the plot **700** may be implemented in the context of any desired environment.

[0089] Similar to plot **704**, plot **700** is shown at zoom level 0.1% but, in comparison to plot **700** which showed a high-pass filtered signal, plot **704** shows an unfiltered signal. However, whereas plot **700** showed clearly a disturbance **702**, no disturbance is readily observed in plot **704**. Additionally, due to the large low frequency signal in plot **704**, it is not possible to visually identify the disturbance. However, application of a high pass filter may remove the low frequency signal, and the remaining high-frequency signal may include a visible disturbance, as emphasized in plot **700**. To this end, application of a high pass filter to the unfiltered signal (as shown in FIG. 7A) may cause low frequency data to be removed (while allowing high-frequency data to remain), resulting in high-frequency signals containing a visible disturbance (as shown in FIG. 7B).

[0090] FIG. 8A illustrates a plot showing exemplary data with an unfiltered 60 Hz fundamental signal at zoom level 0.01%, S value of 5000000, and T value of 512, in accordance with one embodiment. As an option, the plot **800** may

be implemented in the context of any one or more of the embodiments set forth in any previous and/or subsequent figure(s) and/or description thereof. However, it is to be appreciated that the plot **800** may be implemented in the context of any desired environment.

[0091] As shown in plot **800**, at zoom level 0.01%, many disturbances **802** may be observed. Here, the shading **804** between the maximum value and the minimum value may also be readily observed. Additionally, plot **800** shows that the disturbance is so great, it may affect the overall voltage magnitude. In view of such, at extreme zoom levels (e.g. such as 0.01%) the representation of the maximum value and the minimum value may be used as a magnitude estimate. For example, min max downsampling may allow to down-sample at a rate that is higher than an underlying fundamental frequency. Further, if a fundamental wave is 60 Hz and the sample acquisition rate is 10 kHz, then approximately 167 samples per 60 Hz waveform may result. If the min max downsample rate is wider than the fundamental frequency sampling period (e.g. 167 samples), then each waveform may be represented by a single min and single max which may be the max and min samples peaks of the waveform. Such representation may be an approximation of a peak of the waveform. In one embodiment, the representation may be further interpolated to a higher sampling rate in order to determine a more precise peak and trough.

[0092] FIG. 8B illustrates a plot **806** showing exemplary data with a high-pass filtered 60 Hz fundamental signal at zoom level 0.01%, S value of 5000000, and T value of 512, in accordance with one embodiment. As an option, the plot **806** may be implemented in the context of any one or more of the embodiments set forth in any previous and/or subsequent figure(s) and/or description thereof. However, it is to be appreciated that the plot **806** may be implemented in the context of any desired environment.

[0093] Similar to plot **800**, plot **806** is shown at zoom level 0.01% but, in comparison to plot **800** which showed an unfiltered signal, plot **806** shows a high-pass filtered signal. Similar to plot **800**, plot **806** shows multiple disturbances **806** which may be readily and easily observed. Further, the shading **808** between the maximum value and the minimum value may also be readily observed. At such an extreme zoom level of 0.01% and with an S value of 5000000 and a T value of 512, nearly 9766 bins would result (i.e. T bins of S/T width). Such a plot emphasizes the need for using maximum values and minimum values, else the processor would be increasingly consumed in trying to display all raw data points. Rather than display all raw data points, however, through applying the method described herein, the processor can focus on displaying just the maximum value and the minimum value, thereby effectively reducing processor load and demands.

[0094] FIG. 9 illustrates a method **900** for transferring information for generating a representation of high-frequency signal data, in accordance with one embodiment. As an option, the method **900** may be implemented in the context of any one or more of the embodiments set forth in any previous and/or subsequent figure(s) and/or description thereof. Of course, however, the method **900** may be implemented in the context of any desired environment. Further, the aforementioned definitions may equally apply to the description below.

[0095] As shown, per operation **902**, a plot of the maximum value(s) and the minimum value(s) is received. In

various embodiments, the plot may be received by an IED, a device connected to an IED, a database, a server, and/or any device capable of receiving the plot and/or input data. Next, per operation **904**, in one embodiment, a package is created of the plot, the maximum value(s), the minimum value(s), and accompanying metadata. In another embodiment, a package may not be created and the plot of the maximum value(s) and the minimum value(s) may be directly stored on a first device and then transferred to a second device. In the context of the present description, the metadata may include any information associated with the plot, the input data, the maximum value(s), or the minimum value(s). For example, in one embodiment, the metadata may include a date and time of the plot, a location (e.g. sensor device, etc.) from which the signal data originated, etc.

[0096] Additionally, per operation **906**, the package is stored at a first device. The first device may be an IED, a device connected to an IED (e.g. mass storage **284**), a database, a server, and/or any device capable of saving the package. In one embodiment, the first device may store the package for a set time period, or after transferring the package to a second device (per operation **912**), the first device may delete such package from the first device.

[0097] Next, per operation **908**, an applicable second device is identified. For example, a downstream device (from the first device), a managing device, or a device associated with a technician and/or administrator, may be identified as being applicable to the data contained within the package. Additionally, a sample of high-frequency signal data may include a maximum value and a minimum value corresponding with a detected signal anomaly. A first IED that captured such signal data may identify accompanying metadata such as a data, time, location, sensor identification, magnitude of the error (e.g. priority of error ranking, etc.), etc. The first IED (or any device receiving the input data), based on the metadata captured, may determine that the error should be escalated to a managing technician and send the package to such managing technician for review. In this manner, the first IED receives the sample of signal data, creates a downsampled package (e.g. to decrease data amount, etc.), identifies where the package should be sent, and sends the package to the appropriate destination.

[0098] Moreover, per decision **910**, it is determined whether the second device is ready for transfer. In one instance, the second device may be ready immediately. In other instances, the second device may be offline for at time period or otherwise temporarily unavailable. Still yet, if the first device communicates with the second device via an intermediary device (e.g. server, relay station, etc.), the first device may relay the package to the intermediary device to be forwarded on to the second device when it is available. If the second device is not ready for transfer, then the method loops back to decision **910**. Once the second device is available, then per operation **912**, the package is transferred to the second device.

[0099] Additionally, the package may be analyzed at the second device per operation **914**. For example, the package may be scanned for one or more error flags, a detected anomaly(ies), etc. Based on the analysis, per operation **916**, an action is applied. Such action may include notifying a user (e.g. technician, etc.), saving the plot as an image (e.g. TIFF, etc.), compiling the package as a formal report to be sent to one or more individuals, causing an effect (e.g. close,

start, shut-down, verify data, reset, etc.) to occur on a power system component (e.g. sensor, generator, etc.), etc. In one embodiment, if analyzing the package does not identify any needed actions, the package may be configured to be presented to a user (e.g. technician) for review. For example, the plot may be displayed with the maximized value and the minimized value for presentation to an end user, wherein the end user may manipulate the plot (e.g. zooming in and out) to more effectively analyze any potential discrepancies. In such manner, the package may be manually reviewed for accuracy.

[0100] Next, it is determined per decision **918** whether all actions are done. If not, then per operation **920**, the next action is applied based on the analysis (see operation **914**). Once all actions have been completed, then the method ends. In this manner, all actions identified by the second device may be implemented.

[0101] In one embodiment, the representation of high-frequency signal data may include generating a thumbnail of the plot, a preconfigured size (e.g. 1024x512 pixels) image of the plot, etc. Such a thumbnail or preconfigured size image may be sent downstream to a subsequent device for processing. For example, if the minimum value and maximum value (as displayed on the plot) were received by a second device, such second device may analyze the contents, which may in turn trigger an action to analyze the data further, send the package on to another device, etc. In one embodiment, the second device may choose to ignore the package (i.e. no high priority disturbances were detected or did not surpass a preconfigured threshold, etc.).

[0102] In another embodiment, the package sent to a second device (or any subsequent device) may include compressed data (e.g. the plot, the minimum value(s), the maximum value(s)). The subsequent device may first analyze the metadata (which may not be compressed) to determine if the compressed package warrants to be uncompressed and further analyzed. If the metadata, for example, indicates that the disturbance is of minimal system impact, the system may rank the package low, until a low-point time is found (where no other higher ranking packages need an action to be taken) when such package can be uncompressed and analyzed. In another embodiment, if the package ranks below a predetermined ranking threshold, the system may proceed to discard the package and not take any further action.

[0103] FIG. **10A** illustrates a process **1000** for identifying min and max downsampled values, in accordance with one embodiment. As an option, the process **1000** may be implemented in the context of any one or more of the embodiments set forth in any previous and/or subsequent figure(s) and/or description thereof. However, it is to be appreciated that the process **1000** may be implemented in the context of any desired environment.

[0104] As shown, process **1000** includes input data (represented as "x(n)") which can then be subsequently max downsampled **1002** or min downsampled **1004**. Each max downsampling and each min downsampling can then be each iteratively downsampled further to N iterations. As an example, a first max downsampling of 10x may result in a max downsampling of 10x. A subsequent max downsampling of an additional 10x may result in a max downsampling of 100x, and so forth to N iterations. In like manner, a first min downsampling of 10x may result in a min downsampling of 10x. A subsequent min downsampling of

an additional 10× may result in a min downsampling of 100×, and so forth to N iterations. In one embodiment, a pre-identification of a pre-maximum value and a pre-minimum value may be identified for use in calculating a max/min downsampled value (through applying the process 1000).

[0105] In one embodiment, given a bin of N samples, a minimum value sample and a maximum value sample may represent a min and max for such bin. Additionally, a determination of a minimum value sample and maximum value sample may be performed for each bin range. For example, in one embodiment, process 1000 may be used to satisfy operation 312 where, for each bin, the maximum value $x_{\max}[k]$ and the minimum value $x_{\min}[k]$ may be identified and/or calculated. Further, when using one or more min and max outputs to cascade into further min and max downsampling (as shown in process 1000), an initial minimum value (or intermediately determined minimum value) may be used as a basis for the ultimately determined minimum value, and an initial maximum value (or intermediately determined maximum value) may be used as a basis for the ultimately determined maximum value.

[0106] Further, each layer of processed data (e.g. original data, 10× Max downsampled data, 100× Max downsampled data, etc.) may be stored in a database (e.g. local, remote, etc.). To this end, the stored data may allow rapid display of both zoomed-out data (including pre-computation of zoomed out views). In this manner, recording signal data at a variety of zoom levels may allow to quickly display associated minimum and maximum waveforms at any arbitrary zoom level (e.g. from full original data to any time (years), etc.).

[0107] FIG. 10B illustrates a plot 1006 applying the process 1000, in accordance with one embodiment. As an option, the plot 1006 may be implemented in the context of any one or more of the embodiments set forth in any previous and/or subsequent figure(s) and/or description thereof. However, it is to be appreciated that the plot 1006 may be implemented in the context of any desired environment.

[0108] As shown, plot 1006 shows an exemplary plot of a signal, where compressed packet sizes are shown in bytes per packet number.

[0109] FIG. 10C illustrates a plot 1008 which is a 10× downsampling of plot 1006, in accordance with one embodiment. As an option, the plot 1008 may be implemented in the context of any one or more of the embodiments set forth in any previous and/or subsequent figure(s) and/or description thereof. However, it is to be appreciated that the plot 1008 may be implemented in the context of any desired environment.

[0110] As shown, plot 1008 is a 10× min downsampling and a 10× max downsampling of plot 1006.

[0111] FIG. 10D illustrates a plot 1010 which is a 100× downsampling of plot 1006, in accordance with one embodiment. As an option, the plot 1010 may be implemented in the context of any one or more of the embodiments set forth in any previous and/or subsequent figure(s) and/or description thereof. However, it is to be appreciated that the plot 1010 may be implemented in the context of any desired environment.

[0112] As shown, plot 1010 is a 100× min downsampling and a 100× max downsampling of plot 1006.

[0113] FIG. 10E illustrates a plot 1012 of a voltage signal, in accordance with one embodiment. As an option, the plot 1012 may be implemented in the context of any one or more of the embodiments set forth in any previous and/or subsequent figure(s) and/or description thereof. However, it is to be appreciated that the plot 1012 may be implemented in the context of any desired environment.

[0114] As shown, a raw voltage signal corresponds with plot 1012. As will be shown hereinafter (e.g. in FIGS. 10F-10J), plot 1012 may be downsampled in stages. Additionally, FIG. 10K is a high pass filtered version of plot 1012. In one embodiment, min max downsampling may be applied to signals after other filtering (e.g. including any filtering needed to represent the signal in such a way as to facilitate analysis of specific aspects of that signal) has occurred. For example, a high pass filter may be applied to the original signal in order to remove low frequency information that may not be of interest when performing high-frequency analysis.

[0115] FIG. 10F illustrates a plot 1014 of a 10× min max downsampled signal of plot 1012, in accordance with one embodiment. As an option, the plot 1014 may be implemented in the context of any one or more of the embodiments set forth in any previous and/or subsequent figure(s) and/or description thereof. However, it is to be appreciated that the plot 1014 may be implemented in the context of any desired environment.

[0116] As shown, plot 1014 is a 10× min downsampling and a 10× max downsampling of plot 1012.

[0117] FIG. 10G illustrates a plot 1016 of a 100× min max downsampled signal of plot 1012, in accordance with one embodiment. As an option, the plot 1016 may be implemented in the context of any one or more of the embodiments set forth in any previous and/or subsequent figure(s) and/or description thereof. However, it is to be appreciated that the plot 1016 may be implemented in the context of any desired environment.

[0118] As shown, plot 1016 is a 100× min downsampling and a 100× max downsampling of plot 1012.

[0119] FIG. 10H illustrates a plot 1018 of a 1000× min max downsampled signal of plot 1012, in accordance with one embodiment. As an option, the plot 1018 may be implemented in the context of any one or more of the embodiments set forth in any previous and/or subsequent figure(s) and/or description thereof. However, it is to be appreciated that the plot 1018 may be implemented in the context of any desired environment.

[0120] As shown, plot 1018 is a 1000× min downsampling and a 1000× max downsampling of plot 1012.

[0121] FIG. 10I illustrates a plot 1020 of a 10000× min max downsampled signal of plot 1012, in accordance with one embodiment. As an option, the plot 1020 may be implemented in the context of any one or more of the embodiments set forth in any previous and/or subsequent figure(s) and/or description thereof. However, it is to be appreciated that the plot 1020 may be implemented in the context of any desired environment.

[0122] As shown, plot 1020 is a 10000× min downsampling and a 10000× max downsampling of plot 1012.

[0123] FIG. 10J illustrates a plot 1022 of a 20000× min max downsampled signal of plot 1012, in accordance with one embodiment. As an option, the plot 1022 may be implemented in the context of any one or more of the embodiments set forth in any previous and/or subsequent

figure(s) and/or description thereof. However, it is to be appreciated that the plot **1022** may be implemented in the context of any desired environment.

[0124] As shown, plot **1022** is a 20000× min downsampling and a 20000× max downsampling of plot **1012**.

[0125] FIG. **10K** illustrates a plot **1024** of a high pass filter applied to a voltage signal, in accordance with one embodiment. As an option, the plot **1024** may be implemented in the context of any one or more of the embodiments set forth in any previous and/or subsequent figure(s) and/or description thereof. However, it is to be appreciated that the plot **1024** may be implemented in the context of any desired environment.

[0126] As shown, plot **1024** shows a modification of plot **1012** where a high pass filter has been applied. In one embodiment, min max filtering (as shown, e.g., in plot **1024**) may allow for analysis of a voltage signal with respect to absolute peaks of the waveforms over time when zoomed out sufficiently (which may depend on the original acquisition sample rate). For example, if sampling at 1 MHz and where a fundamental frequency is between 50 and 70 Hz, then the voltage signal may be downsampled by a factor of 20000× to ensure at least one waveform per downsample window. If it were desired to investigate the voltage signal at a lesser downsampling amount, a root mean square (“RMS”) transform may be applied to the original voltage signal. Of course, it is noted that other forms of filtering and transformations may be applied to min max downsampling. The examples therefore presented herewith are not intended to be limiting in any manner.

[0127] FIG. **10L** illustrates a plot **1026** of a 10× min max downsampled signal of plot **1024**, in accordance with one embodiment. As an option, the plot **1026** may be implemented in the context of any one or more of the embodiments set forth in any previous and/or subsequent figure(s) and/or description thereof. However, it is to be appreciated that the plot **1026** may be implemented in the context of any desired environment.

[0128] As shown, plot **1026** is a 10× min downsampling and a 10× max downsampling of plot **1024**.

[0129] FIG. **10M** illustrates a plot **1028** of a 100× min max downsampled signal of plot **1024**, in accordance with one embodiment. As an option, the plot **1028** may be implemented in the context of any one or more of the embodiments set forth in any previous and/or subsequent figure(s) and/or description thereof. However, it is to be appreciated that the plot **1028** may be implemented in the context of any desired environment.

[0130] As shown, plot **1028** is a 100× min downsampling and a 100× max downsampling of plot **1024**.

[0131] FIG. **10N** illustrates a plot **1030** of a 1000× min max downsampled signal of plot **1024**, in accordance with one embodiment. As an option, the plot **1030** may be implemented in the context of any one or more of the embodiments set forth in any previous and/or subsequent figure(s) and/or description thereof. However, it is to be appreciated that the plot **1030** may be implemented in the context of any desired environment.

[0132] As shown, plot **1030** is a 1000× min downsampling and a 1000× max downsampling of plot **1024**. Additionally, plot **1030** shows a min and max value at each time value with a shading (e.g. shown as crisscross lines, etc.) in between each of the min and max values. In other embodiments, display of the min and max values may include at

least one of: 1) two signal waveforms, one at a minimum and one at a maximum; 2) two signal waveforms displayed in bold, with shading between (as presently shown in plot **1030**); and 3) shading between and including the minimum and maximum values, without bolding the signals at the actual minimum and maximum.

[0133] In various embodiments, min max downsampling may occur in stages and may be applied to a raw voltage signal. Further, a high pass filter may be applied to a raw voltage signal for further processing. Additionally, high pass filtering followed by min max downsampling may allow for investigation of very large amounts of data for excursions beyond known thresholds.

[0134] FIG. **11** illustrates a network architecture **1100**, in accordance with one possible embodiment. As shown, at least one network **1102** is provided. In the context of the present network architecture **1100**, the network **1102** may take any form including, but not limited to a telecommunications network, a local area network (LAN), a wireless network, a wide area network (WAN) such as the Internet, peer-to-peer network, cable network, etc. While only one network is shown, it should be understood that two or more similar or different networks **1102** may be provided.

[0135] Coupled to the network **1102** is a plurality of devices. For example, a server computer **1112** and an end user computer **1108** may be coupled to the network **1102** for communication purposes. Such end user computer **1108** may include a desktop computer, lap-top computer, and/or any other type of logic. Still yet, various other devices may be coupled to the network **1102** including a personal digital assistant (PDA) device **1110**, a mobile phone device **1106**, a television **1104**, etc.

[0136] FIG. **12** illustrates an exemplary system **1200**, in accordance with one embodiment. As an option, the system **1200** may be implemented in the context of any of the devices of the network architecture **1100** of FIG. **11**. Of course, the system **1200** may be implemented in any desired environment.

[0137] As shown, a system **1200** is provided including at least one central processor **1202** which is connected to a bus **1212**. The system **1200** also includes memory **1204** [e.g. random access memory (RAM), etc.]. The system **1200** also includes a communication interface **1208** and an I/O interface **1210**.

[0138] The system **1200** may also include a secondary storage **1206**. The secondary storage **1206** includes, for example, a hard disk drive and/or a removable storage drive, representing a floppy disk drive, a magnetic tape drive, a compact disk drive, etc. The removable storage drive reads from and/or writes to a removable storage unit in a well known manner.

[0139] Computer programs, or computer control logic algorithms, may be stored in the main memory **1204**, the secondary storage **1206**, and/or any other memory, for that matter. Such computer programs, when executed, enable the system **1200** to perform various functions (as set forth above, for example). Memory **1204**, storage **1206** and/or any other storage are possible examples of non-transitory computer-readable media.

[0140] It is noted that the techniques described herein, in an aspect, are embodied in executable instructions stored in a computer readable medium for use by or in connection with an instruction execution machine, apparatus, or device, such as a computer-based or processor-containing machine,

apparatus, or device. It will be appreciated by those skilled in the art that for some embodiments, other types of computer readable media are included which may store data that is accessible by a computer, such as magnetic cassettes, flash memory cards, digital video disks, Bernoulli cartridges, random access memory (RAM), read-only memory (ROM), and the like.

[0141] As used here, a “computer-readable medium” includes one or more of any suitable media for storing the executable instructions of a computer program such that the instruction execution machine, system, apparatus, or device may read (or fetch) the instructions from the computer readable medium and execute the instructions for carrying out the described methods. Suitable storage formats include one or more of an electronic, magnetic, optical, and electromagnetic format. A non-exhaustive list of conventional exemplary computer readable medium includes: a portable computer diskette; a RAM; a ROM; an erasable programable read only memory (EPROM or flash memory); optical storage devices, including a portable compact disc (CD), a portable digital video disc (DVD), a high definition DVD (HD-DVD™), a BLU-RAY disc; and the like.

[0142] It should be understood that the arrangement of components illustrated in the Figures described are exemplary and that other arrangements are possible. It should also be understood that the various system components (and means) defined by the claims, described below, and illustrated in the various block diagrams represent logical components in some systems configured according to the subject matter disclosed herein.

[0143] For example, one or more of these system components (and means) may be realized, in whole or in part, by at least some of the components illustrated in the arrangements illustrated in the described Figures. In addition, while at least one of these components are implemented at least partially as an electronic hardware component, and therefore constitutes a machine, the other components may be implemented in software that when included in an execution environment constitutes a machine, hardware, or a combination of software and hardware.

[0144] More particularly, at least one component defined by the claims is implemented at least partially as an electronic hardware component, such as an instruction execution machine (e.g., a processor-based or processor-containing machine) and/or as specialized circuits or circuitry (e.g., discreet logic gates interconnected to perform a specialized function). Other components may be implemented in software, hardware, or a combination of software and hardware. Moreover, some or all of these other components may be combined, some may be omitted altogether, and additional components may be added while still achieving the functionality described herein. Thus, the subject matter described herein may be embodied in many different variations, and all such variations are contemplated to be within the scope of what is claimed.

[0145] In the description above, the subject matter is described with reference to acts and symbolic representations of operations that are performed by one or more devices, unless indicated otherwise. As such, it will be understood that such acts and operations, which are at times referred to as being computer-executed, include the manipulation by the processor of data in a structured form. This manipulation transforms the data or maintains it at locations in the memory system of the computer, which reconfigures

or otherwise alters the operation of the device in a manner well understood by those skilled in the art. The data is maintained at physical locations of the memory as data structures that have particular properties defined by the format of the data. However, while the subject matter is being described in the foregoing context, it is not meant to be limiting as those of skill in the art will appreciate that various of the acts and operations described hereinafter may also be implemented in hardware.

[0146] To facilitate an understanding of the subject matter described herein, many aspects are described in terms of sequences of actions. At least one of these aspects defined by the claims is performed by an electronic hardware component. For example, it will be recognized that the various actions may be performed by specialized circuits or circuitry, by program instructions being executed by one or more processors, or by a combination of both. The description herein of any sequence of actions is not intended to imply that the specific order described for performing that sequence must be followed. All methods described herein may be performed in any suitable order unless otherwise indicated herein or otherwise clearly contradicted by context

[0147] The use of the terms “a” and “an” and “the” and similar referents in the context of describing the subject matter (particularly in the context of the following claims) are to be construed to cover both the singular and the plural, unless otherwise indicated herein or clearly contradicted by context. Recitation of ranges of values herein are merely intended to serve as a shorthand method of referring individually to each separate value falling within the range, unless otherwise indicated herein, and each separate value is incorporated into the specification as if it were individually recited herein. Furthermore, the foregoing description is for the purpose of illustration only, and not for the purpose of limitation, as the scope of protection sought is defined by the claims as set forth hereinafter together with any equivalents thereof entitled to. The use of any and all examples, or exemplary language (e.g., “such as”) provided herein, is intended merely to better illustrate the subject matter and does not pose a limitation on the scope of the subject matter unless otherwise claimed. The use of the term “based on” and other like phrases indicating a condition for bringing about a result, both in the claims and in the written description, is not intended to foreclose any other conditions that bring about that result. No language in the specification should be construed as indicating any non-claimed element as essential to the practice of the claimed subject matter.

[0148] The embodiments described herein included the one or more modes known to the inventor for carrying out the claimed subject matter. Of course, variations of those embodiments will become apparent to those of ordinary skill in the art upon reading the foregoing description. The inventor expects skilled artisans to employ such variations as appropriate, and the inventor intends for the claimed subject matter to be practiced otherwise than as specifically described herein. Accordingly, this claimed subject matter includes all modifications and equivalents of the subject matter recited in the claims appended hereto as permitted by applicable law. Moreover, any combination of the above-described elements in all possible variations thereof is encompassed unless otherwise indicated herein or otherwise clearly contradicted by context.

What is claimed is:

1. A device, comprising:
 - a non-transitory memory storing instructions; and
 - one or more processors in communication with the non-transitory memory, wherein the one or more processors execute the instructions to:
 - receive input data, wherein the input data is of a first width;
 - process the input data to manage display of the input data, including:
 - dividing the input data into one or more segments based on first criteria including the first width;
 - identifying, from each segment of the one or more segments, a maximum value; and
 - identifying, from each segment of the one or more segments, a minimum value;
 - transform the input data to a visualizable representation of the input data, the visualizable representation of the input data including a plot of the maximum value and the minimum value for each segment of the one or more segments; and
 - display the plot.
2. The device of claim 1, wherein the plot further includes a shaded region between the maximum value and the minimum value for each segment of the one or more segments.
3. The device of claim 2, wherein an overlay is displayed over the plot.
4. The device of claim 3, wherein the overlay includes one of a median value of each segment of the one or more segments or a filtered sampled value, the overlay being displayed in a different color than a color of the shaded region.
5. The device of claim 1, wherein the input data is filtered prior to identifying the maximum value or the minimum value.
6. The device of claim 1, wherein the first width is based on a size of a window.
7. The device of claim 1, wherein the first criteria includes a width of a segment of the one or more segments, wherein the width of the segment is based on a time interval associated with the maximum value or the minimum value.
8. The device of claim 7, wherein the width of the segment is based on one of natural numbers or real numbers.
9. The device of claim 1, wherein the first criteria further includes at least one of a pixel resolution of a window, a zoom factor, a width associated with the maximum value, a width associated with the minimum value, and an error factor associated with the input data.
10. The device of claim 9, wherein the first criteria includes the error factor that is an identified signal disturbance, and wherein the plot presents the identified signal disturbance.
11. The device of claim 1, wherein a pre-identification of a pre-maximum value and a pre-minimum value is used for the first criteria.
12. The device of claim 11, wherein the first criteria include a plurality of zoom factors.
13. The device of claim 1, wherein each of the maximum value and the minimum value is recorded as a vector.
14. The device of claim 1, wherein the processing of the input data includes receiving a maximum value input and a minimum value input, where the maximum value input is used to identify the maximum value, and the minimum value input is used to identify the minimum value.
15. The device of claim 14, wherein a width of the maximum value input differs from a width of the maximum value, and a width of the minimum value input differs from a width of the minimum value.
16. The device of claim 1, wherein the first criteria includes preset optimal settings with a preconfigured zoom level.
17. The device of claim 1, wherein the plot is sent to a downstream device.
18. The device of claim 1, wherein plot is saved with raw data based on the input data, wherein the raw data includes, at a minimum, the maximum value and the minimum value.
19. A computer program product comprising computer executable instructions stored on a non-transitory computer readable medium that when executed by a processor instruct the processor to:
 - receive input data, wherein the input data is of a first width;
 - process the input data to manage display of the input data, including:
 - dividing the input data into one or more segments based on first criteria including the first width;
 - identifying, from each segment of the one or more segments, a maximum value; and
 - identifying, from each segment of the one or more segments, a minimum value;
 - transform the input data to a visualizable representation of the input data, the visualizable representation of the input data including a plot of the maximum value and the minimum value for each segment of the one or more segments; and
 - display the plot.
20. A method, comprising:
 - receiving, using the processor, input data including high-frequency signals, wherein the input data is of a first width;
 - processing, using the processor, the input data to manage display of the input data, including:
 - dividing the input data into one or more segments based on first criteria including the first width;
 - identifying, from each segment of the one or more segments, a maximum value; and
 - identifying, from each segment of the one or more segments, a minimum value;
 - transforming, using the processor, the input data to a visualizable representation of the high-frequency signals, the visualizable representation of the high-frequency signals including a plot of the maximum value and the minimum value for each segment of the one or more segments; and
 - displaying, using the processor, the plot.

* * * * *