

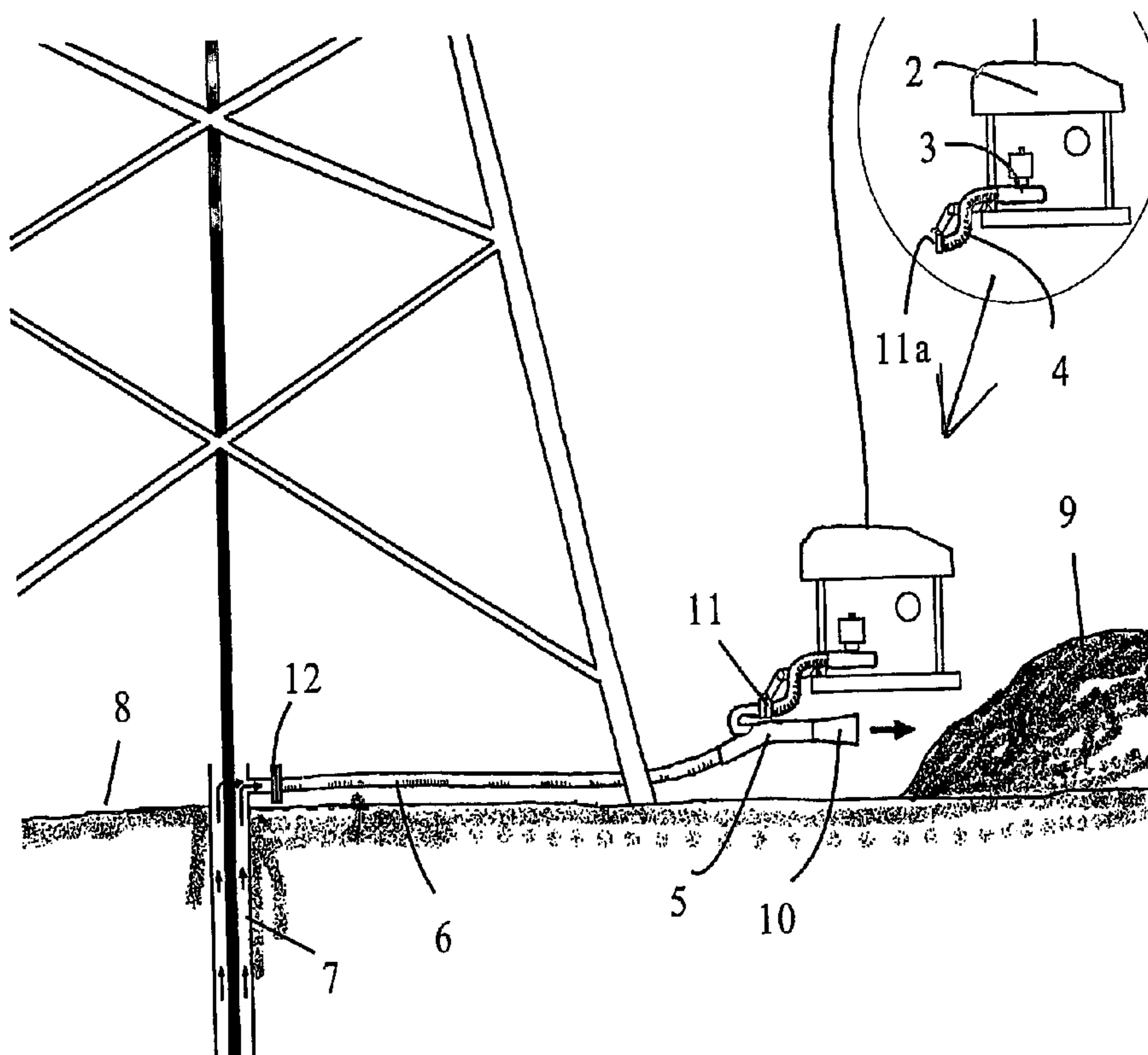

(86) Date de dépôt PCT/PCT Filing Date: 2004/04/22
 (87) Date publication PCT/PCT Publication Date: 2004/11/04
 (45) Date de délivrance/Issue Date: 2012/12/18
 (85) Entrée phase nationale/National Entry: 2005/10/19
 (86) N° demande PCT/PCT Application No.: NO 2004/000110
 (87) N° publication PCT/PCT Publication No.: 2004/094735
 (30) Priorité/Priority: 2003/04/24 (NO20031831)

(51) Cl.Int./Int.Cl. *E02F 3/88* (2006.01)
 (72) Inventeurs/Inventors:
 JACOBSEN, TOM, NO;
 FAGERVOLD, TERJE, NO
 (73) Propriétaire/Owner:
 FOSSURA AS, NO
 (74) Agent: ROBIC

(54) Titre : PROCÉDE ET DISPOSITIF D'ELIMINATION DE DEBLAIS D'UN Puits DE FORAGE SOUS-MARIN
 (54) Title: METHOD AND DEVICE FOR THE REMOVAL OF CUTTINGS FROM A SUBSEA BOREHOLE



(57) Abrégé/Abstract:

Method and device for subsea removal of cuttings from a borehole by means of ejector (5), pump (3) and suction hose (6), the ejector (5) being powered by a pump (3) that is rigidly attached to ROV (2), said ejector (5) being one with external nozzle, while said ROV (2) with pump (3) is connected to the ejector only when removal of cuttings is to take place.

(12) INTERNATIONAL APPLICATION PUBLISHED UNDER THE PATENT COOPERATION TREATY (PCT)

(19) World Intellectual Property
Organization
International Bureau



(43) International Publication Date
4 November 2004 (04.11.2004)

PCT

(10) International Publication Number
WO 2004/094735 A1

(51) International Patent Classification⁷: **E02F 3/88**

(21) International Application Number:
PCT/NO2004/000110

(22) International Filing Date: 22 April 2004 (22.04.2004)

(25) Filing Language: Norwegian

(26) Publication Language: English

(30) Priority Data:
20031831 24 April 2003 (24.04.2003) NO

(71) Applicant (for all designated States except US): **FOS-
SURA AS** [NO/NO]; Leira, N-6590 Tustna (NO).

(72) Inventors; and

(75) Inventors/Applicants (for US only): **JACOBSEN, Tom**
[NO/NO]; Oscar Wistings v. 54, N-7020 Trondheim (NO).
FAGERVOLD, Terje [NO/NO]; Leira, N-6590 Tustna
(NO).

(74) Agent: **CURO AS**; Box 38, N-7231 LUNDAMO (NO).

(81) Designated States (unless otherwise indicated, for every kind of national protection available): AE, AG, AL, AM, AT, AU, AZ, BA, BB, BG, BR, BW, BY, BZ, CA, CH, CN, CO, CR, CU, CZ, DE, DK, DM, DZ, EC, EE, EG, ES, FI, GB, GD, GE, GH, GM, HR, HU, ID, IL, IN, IS, JP, KE, KG, KP, KR, KZ, LC, LK, LR, LS, LT, LU, LV, MA, MD, MG, MK, MN, MW, MX, MZ, NA, NI, NO, NZ, OM, PG, PH, PL, PT, RO, RU, SC, SD, SE, SG, SK, SL, SY, TJ, TM, TN, TR, TT, TZ, UA, UG, US, UZ, VC, VN, YU, ZA, ZM, ZW.

(84) Designated States (unless otherwise indicated, for every kind of regional protection available): ARIPO (BW, GH, GM, KE, LS, MW, MZ, SD, SL, SZ, TZ, UG, ZM, ZW), Eurasian (AM, AZ, BY, KG, KZ, MD, RU, TJ, TM), European (AT, BE, BG, CH, CY, CZ, DE, DK, EE, ES, FI, FR, GB, GR, HU, IE, IT, LU, MC, NL, PL, PT, RO, SE, SI, SK, TR), OAPI (BF, BJ, CF, CG, CI, CM, GA, GN, GQ, GW, ML, MR, NE, SN, TD, TG).

Published:

— with international search report

For two-letter codes and other abbreviations, refer to the "Guidance Notes on Codes and Abbreviations" appearing at the beginning of each regular issue of the PCT Gazette.

(54) Title: METHOD AND DEVICE FOR THE REMOVAL OF CUTTINGS FROM A SUBSEA BOREHOLE

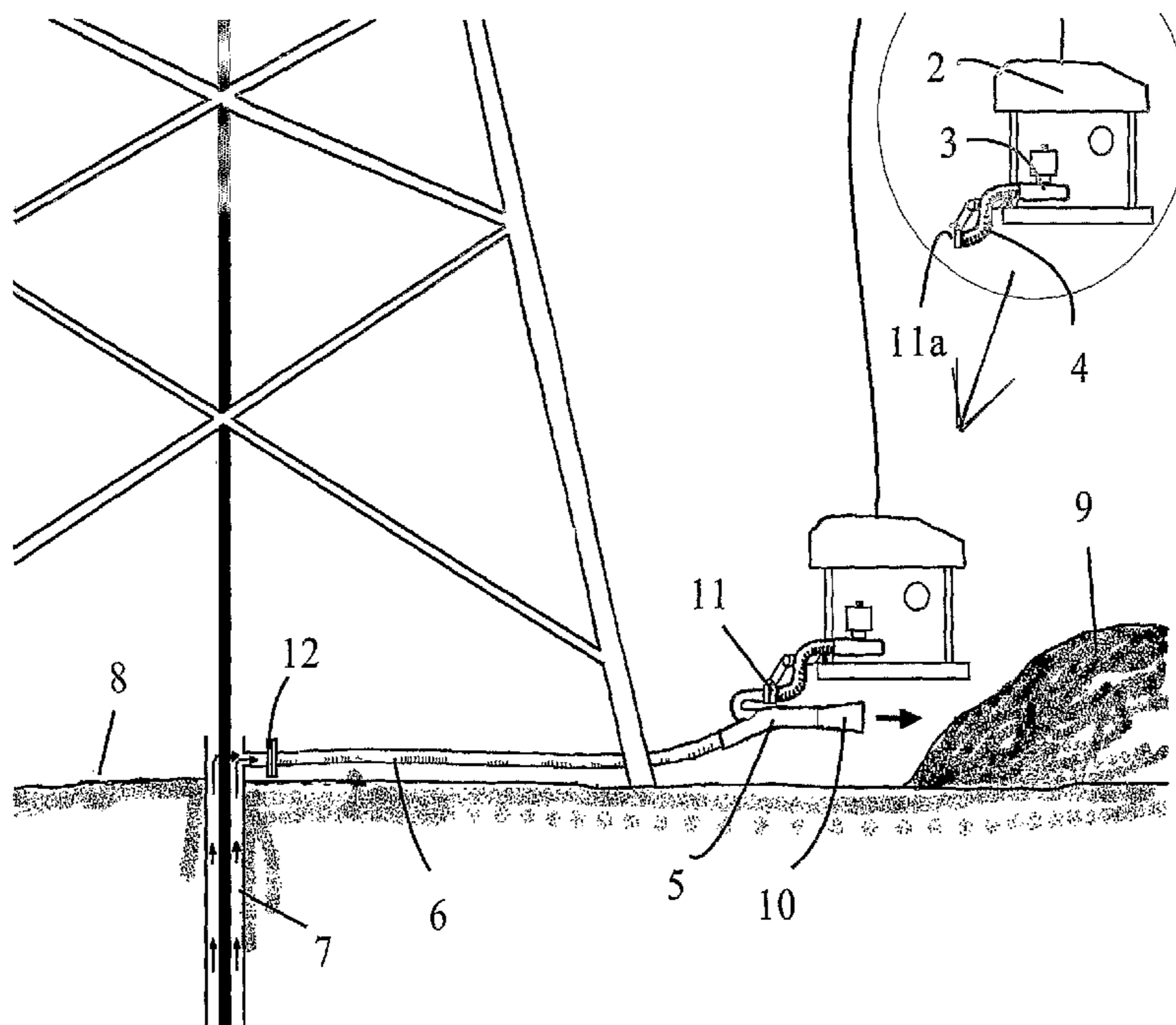

(57) Abstract: Method and device for subsea removal of cuttings from a borehole by means of ejector (5), pump (3) and suction hose (6), the ejector (5) being powered by a pump (3) that is rigidly attached to ROV (2), said ejector (5) being one with external nozzle, while said ROV (2) with pump (3) is connected to the ejector only when removal of cuttings is to take place.

METHOD AND DEVICE FOR THE REMOVAL OF CUTTINGS FROM A SUBSEA BOREHOLE

The present invention relates to a method and a device for the removal of cuttings from subsea boreholes during drilling.

Background

On drilling boreholes in subterranean formations cuttings are formed and are transported to the surface by the drilling fluid. When drilling wells offshore e.g. for oil and/ or gas production, water is commonly used as drilling fluid when drilling the uppermost parts of the holes. The cuttings will thus be contaminated and may be deposited at the sea bottom. From one single well there will typically be formed several hundred cubic meters of cuttings.

It is thus required that the cuttings are transported away from the borehole so as not to deposit large piles that obstruct further work with the well or wellhead and that may damage structures.

As drilling is a very expensive operation, high demands are made to operational reliability and sufficient capacity for the equipment to be used for transporting the cuttings. Surrounding the borehole there may be a guide base through which the drill string is arranged. By connecting a suction hose to such a guide base, the cuttings produced during drilling may be removed.

Prior art technology

Several technologies have been attempted to solve this problem, like the one taught by Norwegian patent No. 302 043. The disadvantage of this and other prior art technologies is that it is highly energy consuming and requires heavy equipment with separate energy supply from the surface. A consequence of the same is the need for transportation of equipment and personnel out to the drilling rig, need for storage room for equipment like winches and energy supplies, and risks related to handling of the equipment on the deck of the drilling rig and lodging of the personnel.

Furthermore there is a disadvantage of several of the prior art technologies that the cross section of the suction system has variations and therefore involves the risks for blocking and temporary stop of the drilling. It is well known that an ejector with an eccentric nozzle may be used for the suction of sediments (NO patent No. 312 541. It has, however, a strict limitation with respect to how far sediment may be transported. Still further it should be noted that an ROV may not be operated with a dredge in the immediate proximity of a drill string during drilling. Said patent

does not give an answer to how to configure the equipment to always have a spare unit at hand or to have units with different properties at hand.

Several different designs of ejectors are known. e.g. from Norwegian patent application No. 2001 4843, wherein the nozzle or nozzles are arranged eccentrically so that a blocking of the ejector is avoided.

It is also common knowledge that for dredging a suction head with two inlets may be applied, allowing the suction head to be positioned on top of sediment without any risk that a suction hose becomes blocked (NO patent application No. 2001 6361).

10 Objectives

It is an object of the present invention to provide a method and a device for transporting cuttings from a subsea borehole during drilling, in a manner that is effective and yet requires little equipment.

The invention

The method and the device according to the invention enable the ROV or ROVs used to power the ejector, to be utilized for other applications when there is not a current need for transporting sediment. To achieve the desired versatility the ROV and the ejector are provided with each respective part of a coupling that preferably is operable by the ROV. Thus only a water pump with a particular connecting hose
20 is mounted on the ROV, which may also be used for general purposes.

According to the invention, there is provided a device for removal of cuttings from a borehole with the use of an ejector, comprising:

2a

a first unit in the form of an ROV including a rigidly attached ejector pump and a connecting hose attached to the ejector pump, the connecting hose terminating at an opposite end with a first coupling part ; and

a second unit movable with respect to the ROV, and comprising an ejector with a hose attached thereto, said ejector comprising a second coupling part,

said first coupling part and said second coupling part comprising rapid coupling means and a locking member operable by external manipulators, for enabling rapid connection and disconnection of the first and second units.

10 It is furthermore highly preferred that the pipe or hose system connected to the ejector has a constant diameter or at least is free from constrictions in the direction from the inlet end to the outlet end, to avoid obstacles that may lead to a blocking.

It is a benefit of the present method that it renders it possible to remove cuttings continuously while drilling the borehole, which constitutes a preferred embodiment of the method according to the invention.

To reduce the loss of energy the outlet side of the ejector is designed with a gradually increasing cross section. Such an outlet is commonly referred to as a "diffuser".

20

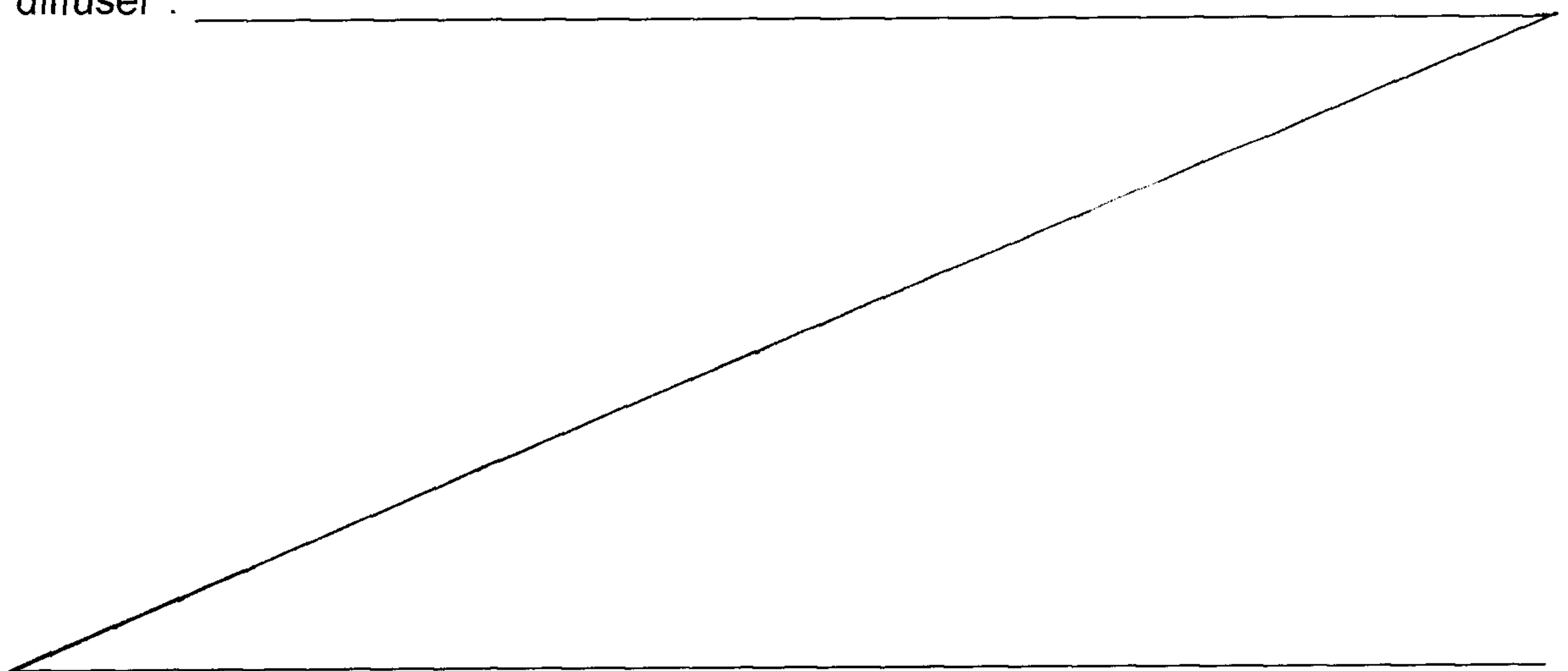

Another advantage of the method and the device according to the invention is that it comprises a lightweight, ROV based suction equipment (corresponding to Norwegian patent No. 312 541) to remove sediment from sites with limited (constricted) access. Thereby the water pump supplying water to the ejector may be powered by the standard power supply for the ROV. The suction unit as such is designed in a way that it not only gets access to constricted sites, but also in a way as to not damage vulnerable components and equipment.

The invention in more detail

Figure 1 is a schematic view of an embodiment of a device according to the invention.

Figure 2 is a view of a "spare" ejector with a suction hose according to the invention.

Figure 3 is a schematic view of an alternative device according to the invention.

Figure 4 is a view of the embodiment according to Figure 1, also including a hose on the pressure side of the ejector.

Figure 5 shows an alternative to the embodiments shown in Figure 1 and Figure 4.

Figure 1 shows schematically how an assembly (unit) 1 (encircled) comprising an ROV 2 with thereto attached water pump 3, connecting hose 4 and a first part 11a of a coupling, may be moved adjacent to, and easily be connected to another unit comprising the ejector 5 with suction hose 6 or pipe that in the Figure is shown connected to a borehole 7 close to the sea bottom 8, in order to pump cuttings from the borehole to a land fill 9 at a distance from the borehole 7. The ejector 5 is furnished with another part 11b of the coupling 11, adapted to be connected to the first part 11a of said coupling.

The suction hose or pipe 6 has a mainly constant cross section along its entire length and is arranged as straight as possible. The ejector 5 comprises a tubing of mainly constant diameter corresponding to the diameter of the suction hose 6. In the shown embodiment the ejector is furnished with a widened outlet end piece 10 functioning as a diffuser and contributes to provide a best possible suction force from the available power. The ejector comprises one or several power nozzles (not shown) that are supplied with water by the water pump 3. It is preferred that the ejector 5 according to the invention is of a type with externally arranged nozzles as described in Norwegian patent No. 312 541. It is still further preferred that the ejector 5 has a straight ejector tubing with two or more nozzles arranged symmetrically around the tubing as described in Norwegian patent application No. 2001 4843.

The assembly 1 of ROV 2/ pump 3/ connecting hose 4 may easily be connected to and disconnected from the ejector 5 as desired, by the coupling 11. This way the ROV may also be

used for other purposes. Furthermore the suction hose 6 may be adapted for connection to the borehole 7 with another coupling 12. It is preferable that the couplings 11 and 12 are of such a type that they may be operated by an ROV, preferably the ROV to which they are to be connected. Typically the coupling 11 will be of a type commonly referred to a rapid coupling. The construction of the coupling 11 as such is not important, though it will generally comprise a locking member that on a short rotating movement or a simple axial movement provides for a sealed locking of the coupling parts 11a and 11b to each other. The locking member will typically be operable by the common, external manipulators arranged on an ROV. The second coupling 12 may be of the same type as coupling 11 or of another type.

The ejector 5 is supplied with water by the water pump 3. A central feature of the method according to the invention is that the current ROV 2 may be connected to an ejector 5 with a suction hose 6 only when the need for removing sediment arises. Thereby the same ROV 2 is available for other operations when there is no need of removing sediment. Incidentally, it is convenient if the water pump 3 for supplying water to the ejector is also arranged to supply water to at least one nozzle arranged at or near the inlet end of the suction hose 6 for back-flushing sediment that possibly get stuck in the inlet opening. This at least one nozzle (not shown) should also be arranged externally of the hose or pipe 6 so as to not limit its cross section.

Normally the ejector 5 will make use of the power available on the current ROV 2, e.g. in the form of hydraulic power. Several work grade ROVs have available a hydraulic power corresponding to 20 - 30 kW. Compared to the need this is a comparatively limited effect. The ejector 5 and suction hose 6 must therefore be designed for optimum utilization of the effect in order to achieve a suction force that is sufficient to remove the amounts of cuttings that are produced. Furthermore it is important that the velocity in the suction hose 6 is sufficiently high to avoid that sediment settles and clogs the suction hose 6 or an optional discharge hose 14. Figure 2 shows a "spare" ejector 5' with suction hose 6' provided with respective parts 11b' and 12a' of couplings 11 and 12. This spare unit may be identical to the unit shown in Figure 1 but it may also be different from this with respect to diameter and/ or length.

It is a preferred feature of the method according to the invention to keep in a state of readiness such a spare unit comprising ejector 5' and suction hose 6', which may easily be connected if the primary unit gets clogged or for other reasons needs to be replaced.

The spare unit may in its state of readiness be located at the sea floor alongside a borehole. It will furthermore be possible to mount the spare unit/ units to the guide base through which the

drill string is arranged, so that replacement to the spare suction hose/ ejector unit may be done very rapidly.

Spare units may have properties that are different from the properties of the primary ejector 5 and suction hose 6. For example the length of the suction hose 6' may be different from the length of the suction hose 6. If the length of the hose gets shorter, the suction capacity will get higher but the sediment will be moved a shorter distance. It is fully possible to hold available several different spare units.

Figure 3 illustrates how an ROV 2 with pump 3 and connecting hose 4 with coupling 11 as shown in Figure 1, may be used with another type of equipment. The other type of equipment shown in Figure 3, is an ejector 15 with a mainly rigid and comparatively short mouth piece 16, for moving sediment away from an area which is typically difficult to access, such as from beneath a fixed construction 13 in the form of a quay, pier or the like.

For many purposes it will be convenient that the suction hose 6 is flexible, since such a hose is simpler to handle than a rigid pipe, and since it allows positioning its outlet end more freely. The inlet end of the suction hose is positioned near the site where the cuttings are discharged from the borehole. If the drill string is positioned within a guide base, there will normally be means for attachment of the suction hose to the same. It should be emphasized that the scope of the invention also includes a rigid pipe, a rigid, hinged pipe or a combination of a rigid pipe and a flexible hose.

Figure 4 shows an alternative embodiment of the invention, by which a discharge hose 14 is arranged at the outlet side or the pressure side of the ejector, for thereby further increasing the distance that the cuttings may be transported away from the borehole. At the end of the discharge hose 14 is shown a device 17 for moving the outermost end of the discharge hose as the landfill 9 of cuttings grows. Like for the suction hose 6 also the discharge hose 14 may have the form of a mainly rigid pipe while it is preferred that at least parts of the discharge hose is flexible.

Figure 5 shows yet another embodiment of the invention. The particular feature of this embodiment is that the ejector unit 5 by means of a coupling 12 is connected directly to a casing or the like of a well without any intermediate suction hose. Like with the embodiment of Figure 4, a discharge hose 14 for the transportation of the cuttings from the ejector 5 to a landfill 9 is connected to the ejector. Since it may be difficult to access the regions close to a well with an

ROV or the like, an extension hose 18 for water is arranged from coupling 11 on ROV 2 to the ejector 5.

It is often a need for renovation/ clearing around a borehole after the drilling has been completed, or a need for removal of sediment that are difficult to access. For such purposes an ejector based dredge that also may be positioned on the sea floor, may be used. This dredge (or if there is a need for more than one these dredges) may be provided with a long pointed suction head that advantageously may be made in a soft material, like plastic. Thus, sediment may be removed from sites that are difficult to access without damaging vulnerable components. The suction head may also have the form of a double pipe, so that it does not risk clogging of the pipe even when working in compact sediment (cf. the suction head of Norwegian patent application No. 2001 6361). There is nothing preventing the use of several different dredges should the need for that arise.

If sediment is to be removed e.g. from a pile of cuttings, it might be desirable to position the suction head on top of the pile. In such cases it is preferred that the inlet end of the suction hose 6, 6' to arrange a suction head with two inlet openings arranged at a vertical distance from one another, so that the uppermost inlet is arranged to suck in only water while the lowermost inlet opening is arranged to suck in sediment and water. Such a suction head may be left alone without control or surveillance without any risk of getting clogged.

WHAT IS CLAIMED IS:

1. Device for removal of cuttings from a borehole with the use of an ejector, comprising:
 - a first unit in the form of an ROV including a rigidly attached ejector pump and a connecting hose attached to the ejector pump, the connecting hose terminating at an opposite end with a first coupling part ; and
 - a second unit movable with respect to the ROV, and comprising an ejector with a hose attached thereto, said ejector comprising a second coupling part ,
 - said first coupling part and said second coupling part comprising rapid
10 coupling means and a locking member operable by external manipulators, for enabling rapid connection and disconnection of the first and second units.
2. Device according to claim 1, wherein the hose is a suction hose having an inlet end opposite to the ejector comprising a first coupling part of a second coupling, arranged to be selectively connected to a second coupling part of the second coupling of a guide base at the borehole.
3. Device according to claim 1 or 2, wherein the ejector pump supplying the ejector with water, is powered by a power supply for the ROV.
4. Device according to claim 2, wherein the ejector has a suction portion attached to an outlet end of the suction hose.
- 20 5. Device according to claim 1, wherein the hose is a discharge hose connected to a discharge portion of the ejector so that the sediment can be transported further away from the borehole.
6. Device according to claim 1, wherein the hose is a discharge hose and the ejector has a suction portion and a discharge portion, the suction portion of the ejector being connected directly to a guide base around the borehole with a second

coupling while the discharge portion of the ejector is connected to the discharge hose.

7. Device according to claim 6, comprising an extension hose to connect said first coupling part of the first unit to the second coupling part of the ejector.

8. Device according to any one of claims 1 to 7, wherein the ejector is of a type having an ejector nozzle arranged completely external of a boring of the ejector tube.

9. Device according to claim 2, wherein at the inlet end of the suction hose, a pipe or suction head with two inlet openings are arranged at a vertical distance from one another, the upper one thus arranged to suck in only water while the lower one is arranged to suck in a combination of sediment and water.

10. Device according to claim 2 or 9, wherein the suction hose and the ejector have a common, substantially constant cross section.

11. Device according to any one of claims 1 to 10, wherein the ejector has a discharge portion with a gradually increasing cross section.

12. Device according to claim 1, wherein the external manipulators are arranged on the first unit.

13. Device according to claim 2, wherein at least one nozzle, arranged for being supplied with water by the pump, is arranged near the inlet end of the suction hose to allow back-flush of water through the suction hose to flush out any sediment that incidentally get stuck at said inlet end.

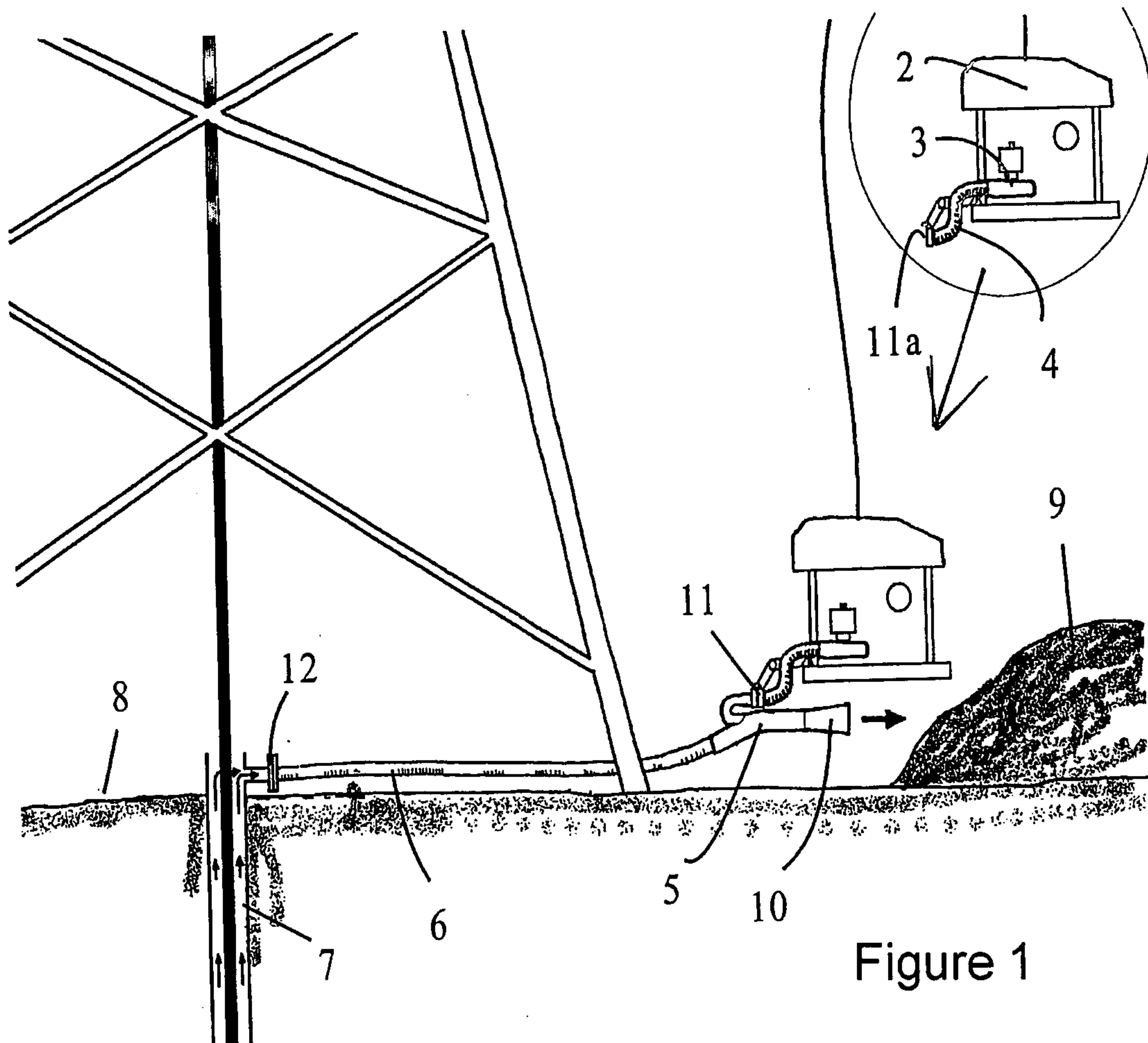

Figure 1

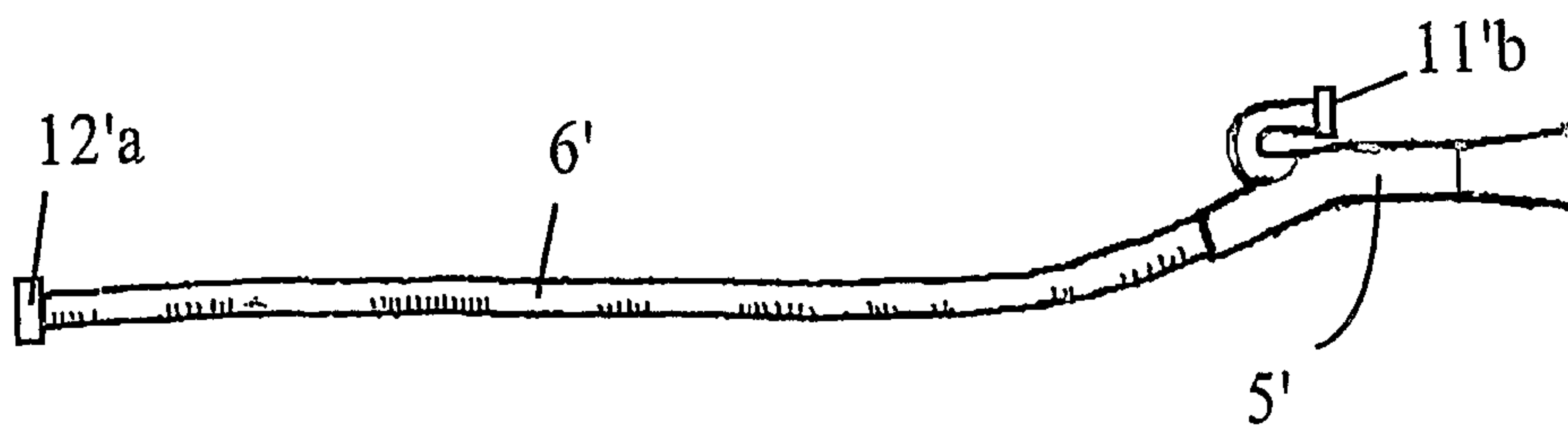

Figure 2

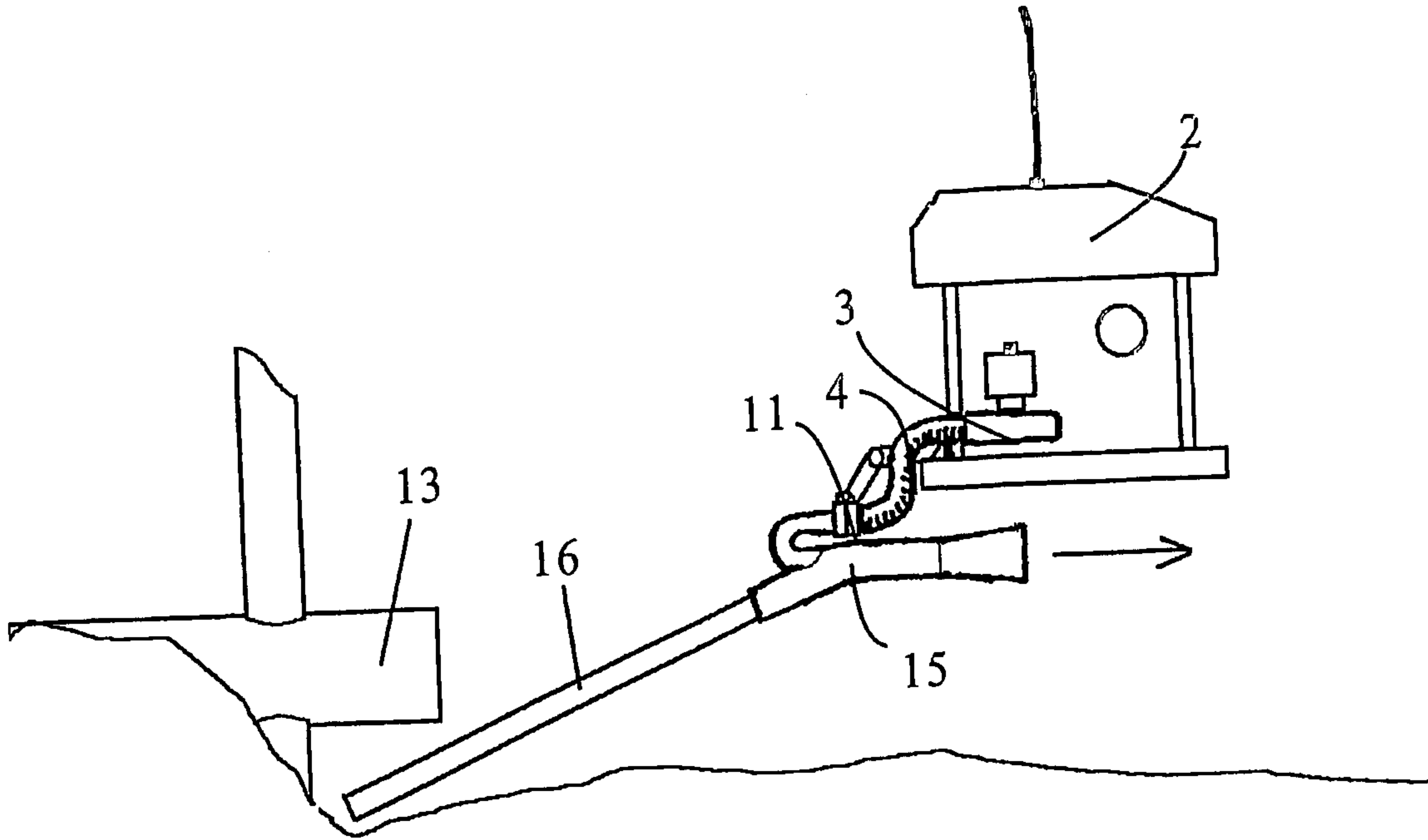

Figure 3

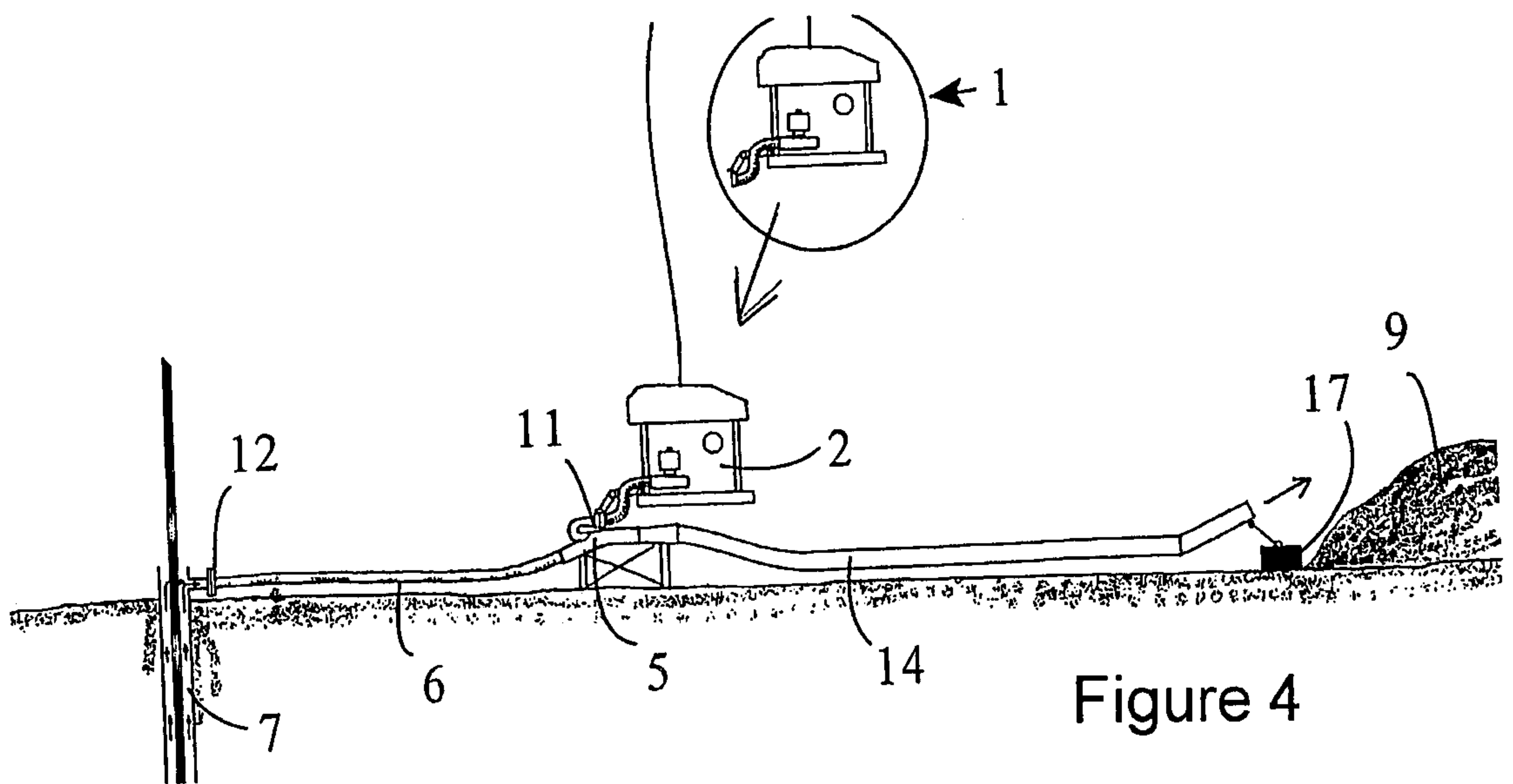

Figure 4

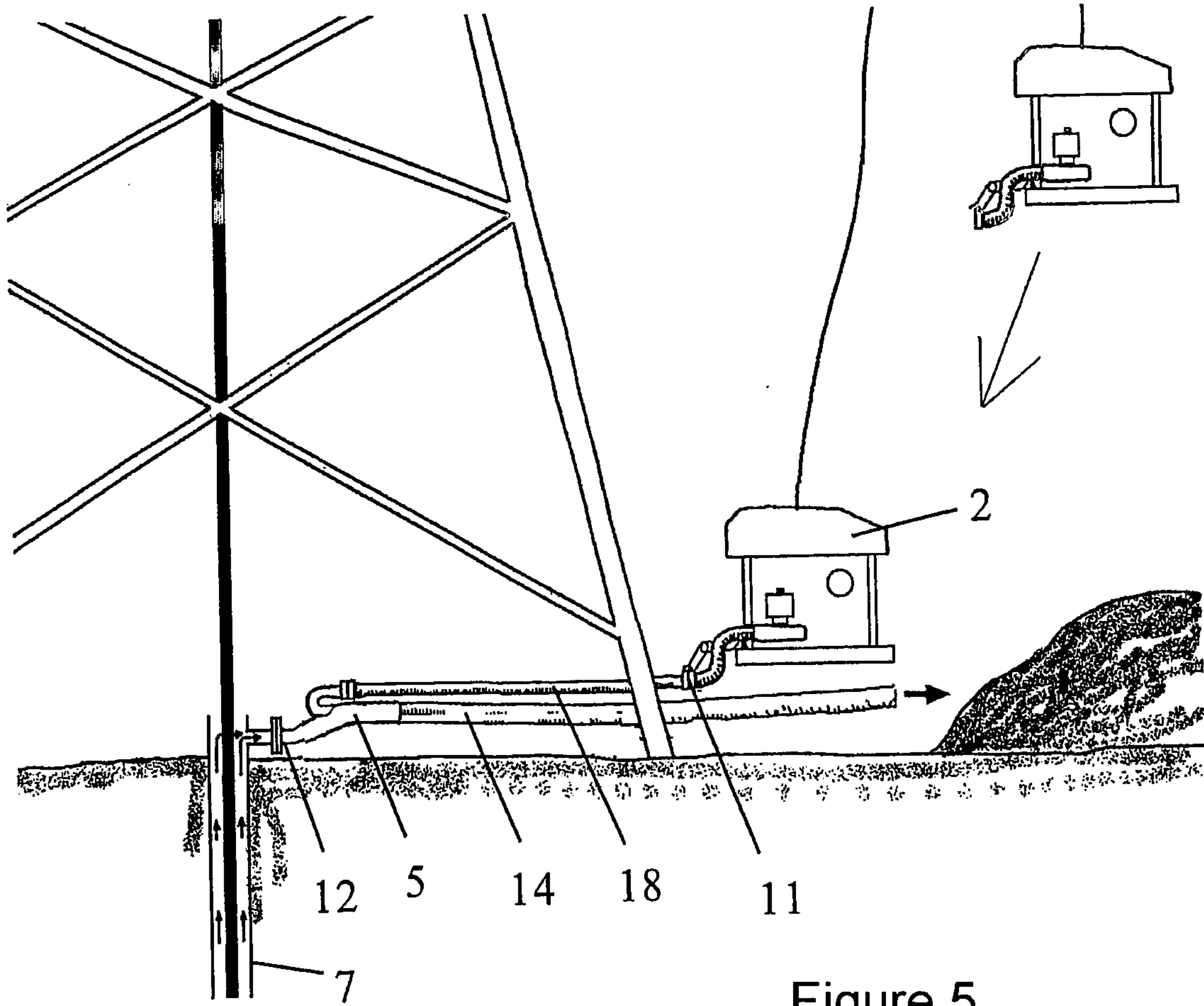

Figure 5

