



(19) **United States**

(12) **Patent Application Publication**
Tseng

(10) **Pub. No.: US 2019/0111656 A1**

(43) **Pub. Date: Apr. 18, 2019**

(54) **COMPOSITE FIBER, COMPOSITE BOARD,
AND METHOD FOR MANUFACTURING
THE COMPOSITE BOARD**

(71) Applicant: **Kai-Hsi Tseng**, Xianxi Township (TW)

(72) Inventor: **Kai-Hsi Tseng**, Xianxi Township (TW)

(21) Appl. No.: **15/730,984**

(22) Filed: **Oct. 12, 2017**

Publication Classification

(51) Int. Cl.	
<i>B32B 5/12</i>	(2006.01)
<i>D01F 8/04</i>	(2006.01)
<i>B32B 5/08</i>	(2006.01)

(52) **U.S. Cl.**
 CPC *B32B 5/12* (2013.01); *D01F 8/04*
 (2013.01); *B32B 5/08* (2013.01); *D10B*
2501/04 (2013.01); *B32B 2262/0253*
 (2013.01); *D10B 2321/021* (2013.01); *D10B*
2321/022 (2013.01); *B32B 2571/00* (2013.01)

(57) **ABSTRACT**
 Provided are a composite fiber, a composite board and a method for manufacturing the composite board. The composite fiber is composed of a core and a shell formed around the core, a melting temperature of the shell is lower than a melting temperature of the core, and the strength of the shell is higher than the strength of the core. The composite fiber can be manufactured into a composite board with high impact strength, high moldability, low ductility, light weight and high heat resistance, and thereby meeting protection requirements.

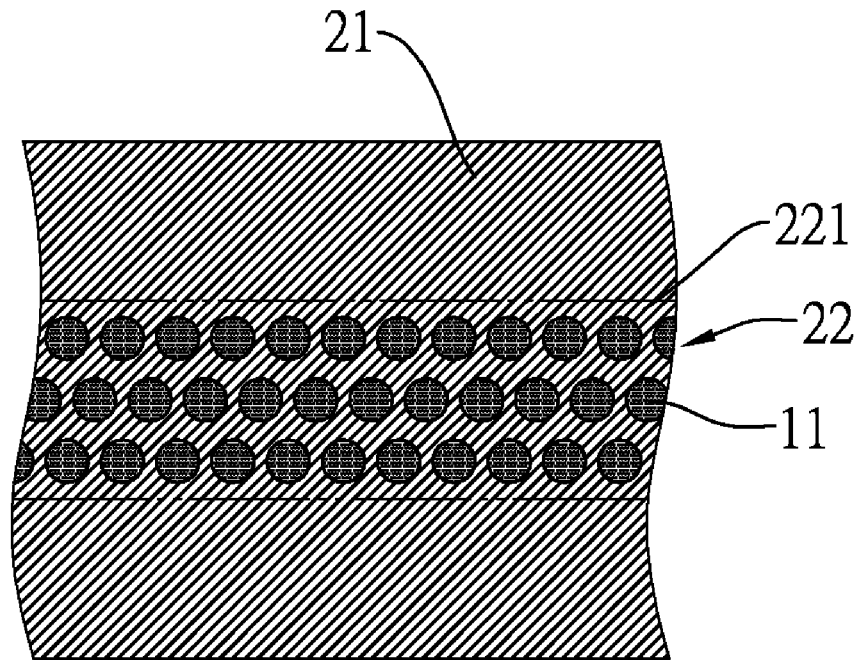

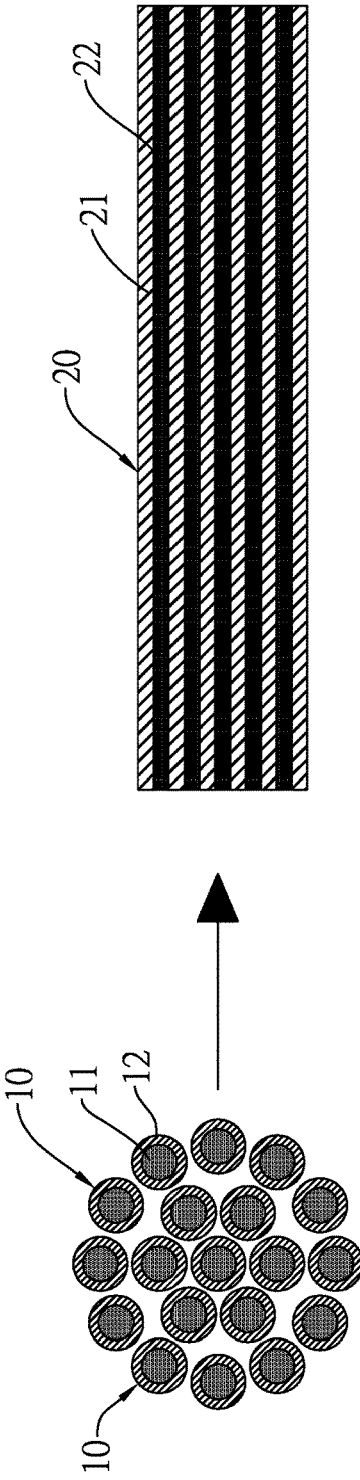

FIG. 1

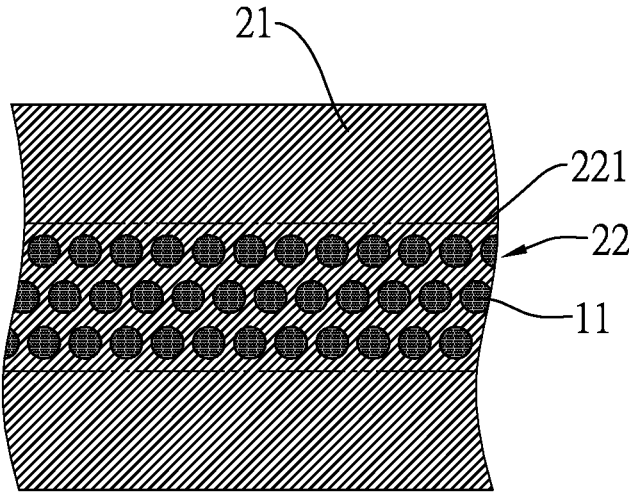

FIG. 2

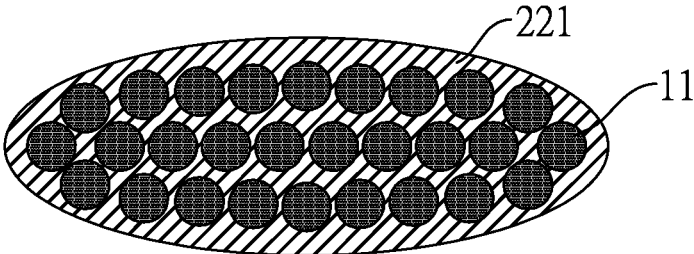

FIG. 3

COMPOSITE FIBER, COMPOSITE BOARD, AND METHOD FOR MANUFACTURING THE COMPOSITE BOARD

BACKGROUND OF THE INVENTION

1. Field of the Invention

[0001] The present invention relates to a composite fiber, a composite board and a method for manufacturing the composite board.

2. Description of the Prior Arts

[0002] Since injuries often occur in sports training or competitions, the prior arts provide a variety of protection products, such as knee pads, ankle pads and elbow pads, for people to choose. Among them, the conventional protection products are made of a single material (e.g., polypropylene fiber) through weaving and molding processes. However, the conventional protection products are made from a single-component fiber, and the strength of the protection products is limited and thus cannot provide good protection.

SUMMARY OF THE INVENTION

[0003] To overcome the shortcomings, the present invention provides a composite fiber that can be simply manufactured into a composite board with good impact strength, thereby meeting the protection requirement.

[0004] To achieve the foresaid objective, the present invention provides a composite fiber composed of a core and a shell formed around the core. A melting temperature of the shell is lower than a melting temperature of the core, and the strength of the shell is higher than the strength of the core.

[0005] Based on the above technical means, the composite fiber is heated at the temperature between the melting temperature of the shell and the melting temperature of the core. Then the composite fiber can be manufactured into a composite board with good impact strength, high moldability, low ductility, light weight and high heat resistance.

[0006] The core is made of polypropylene copolymers or polypropylene homopolymers, and the shell is made of polyethylene copolymers, polyethylene homopolymers, polypropylene copolymers or polypropylene homopolymers.

[0007] The melting temperature of the core is between 160° C. and 180° C. and the melting temperature of the shell is between 120° C. and 140° C.

[0008] To overcome the shortcomings, another objective of the present invention is to provide a composite board with good impact strength.

[0009] For this reason, the present invention provides a composite board made of the foresaid composite fibers, and the composite board comprises multiple substrates and multiple composite layers. The composite layers are arranged alternately with the substrates, each composite layer is composed of multiple cores and a coating body coating the cores, and the coating body is attached to the adjacent substrate.

[0010] The composite layer is made of the shell and the core.

[0011] Besides, another objective of the present invention is to provide a method for manufacturing the composite board.

[0012] For this reason, the present invention provides a method for manufacturing the composite board. The method

comprises: stretching multiple composite fibers and melting the shells of the composite fibers to obtain the composite board.

[0013] Based on the above technical means, the manufacturing method can effectively manufacture a composite board with good structural strength and resistance to the external force.

[0014] Other objectives, advantages and novel features of the invention will become more apparent from the following detailed description when taken in conjunction with the accompanying drawings, rather than limiting the scope of the invention.

BRIEF DESCRIPTION OF THE DRAWINGS

[0015] FIG. 1 is a flow chart of manufacturing a composite board by composite fibers of the present invention;

[0016] FIG. 2 is a partially enlarged view of a composite board of the present invention;

[0017] FIG. 3 is a partially enlarged view of the composite layer in the composite board of the present invention.

DETAILED DESCRIPTION OF THE PREFERRED EMBODIMENTS

[0018] In order to illustrate the technical means adopted by the present invention to achieve the objective, the preferred embodiments of the present invention will be further described in detail below with reference to the drawings.

[0019] As illustrated in FIG. 1, a composite fiber 10 of the present invention is composed of a core 11 and a shell 12. The core 11 is a round bar and the shell 12 is formed around the core 11. A melting temperature of the shell 12 is lower than a melting temperature of the core 11, and the strength of the shell 12 is higher than the strength of the core 11. The shell 12 of each composite fiber 10 is attached to the shell 12 of an adjacent composite fiber 10. In addition, each composite fiber 10 is substantially a round bar.

[0020] In a preferred embodiment, the core 11 is made of polypropylene copolymers or polypropylene homopolymers, while the shell 12 is made of polyethylene copolymers, polyethylene homopolymers, polypropylene copolymers or polypropylene homopolymers. More specifically, the melting temperature of the polyethylene copolymer, polyethylene homopolymer, polypropylene copolymer, and polypropylene homopolymer for the shell 12 is lower than the melting temperature of the polypropylene copolymer and polypropylene homopolymer for the core 11. In other words, the polyethylene copolymer, polyethylene homopolymer, polypropylene copolymer and polypropylene homopolymer for the shell 12 are low-melting point polyethylene copolymer, low-melting point polyethylene homopolymer, low-melting point polypropylene copolymer and low-melting point polypropylene homopolymer respectively, while the polypropylene copolymer and polypropylene homopolymer for the core 11 are high-melting point polypropylene copolymer and high-melting point polypropylene homopolymer respectively.

[0021] In a preferred embodiment, the melting temperature of the core 11 is between 160° C. and 180° C. and the melting temperature of the shell 12 is between 120° C. and 140° C.

[0022] As illustrated in FIG. 1 to FIG. 3, multiple composite fibers 10 can be stretched into a composite board 20 of the present invention under high temperature and high

pressure. The composite board **20** contains multiple substrates **21** and multiple composite layers **22** arranged alternately with the substrate **21**, each composite layer **22** is composed of multiple cores **11** and a coating body **221** coating the cores **11**, and the coating body **221** is attached to the adjacent substrate **21**. The composite layer contains the shell **12** and the core **11**, and the shell **12** is melted and then solidified into the coating body **221** at the temperature between the melting temperature of the shell **12** and the melting temperature of the core **11**.

[0023] Since the melting temperature of the shell **12** of the composite fiber **10** is lower than the melting temperature of the core **11**, the composite fiber **10** can be directly heated to melt the shell **12** but not to melt the core **11**, thereby obtaining the composite board **20**. The shape of the composite board **20** can be custom-made to be both fitted and comfortable based on needs. Since the core **11** is not melted, the composite board **20** made from the composite fiber **10** can have improved overall structural strength and good impact resistance. In addition, compared with a board made from single-component polypropylene fibers, the composite board **20** of the present invention has the advantages of good impact strength, high moldability, as well as low ductility, light weight, high heat resistance, and so on.

[0024] Therefore, the composite fiber **10** of the present invention has an advantage that can be manufactured into a composite board **20** with good impact strength, high moldability, low ductility, light weight and high heat resistance.

[0025] Even though numerous characteristics and advantages of the present invention have been set forth in the foregoing description, together with details of the structure and features of the invention, the disclosure is illustrative only. Changes may be made in the details, especially in matters of shape, size, and arrangement of parts within the principles of the invention to the full extent indicated by the broad general meaning of the terms in which the appended claims are expressed.

1. A composite fiber, which is composed of a core and a shell formed around the core, a melting temperature of the shell being lower than a melting temperature of the core, and the strength of the shell being higher than the strength of the core.

2. The composite fiber as claimed in claim **1**, wherein the core is made of polypropylene copolymers or polypropylene homopolymers, and the shell is made of polyethylene copolymers, polyethylene homopolymers, polypropylene copolymers or polypropylene homopolymers.

3. The composite fiber as claimed in claim **1**, wherein the melting temperature of the core is between 160° C. and 180° C. and the melting temperature of the shell is between 120° C. and 140° C.

4. The composite fiber as claimed in claim **2**, wherein the melting temperature of the core is between 160° C. and 180° C. and the melting temperature of the shell is between 120° C. and 140° C.

5. A composite board made of multiple composite fibers, wherein the composite fibers are each composed of a core and a shell formed around the core, a melting temperature of the shells is lower than a melting temperature of the cores, and the strength of the shells is higher than the strength of the cores; and

the composite board comprises:

multiple substrates; and

multiple composite layers which are arranged alternately with the substrates, each composite layer composed of the cores of the composite fibers and a coating body coating the cores, and the coating body attached to the adjacent substrate;

wherein the composite layer is made of the shell and the core.

6. The composite board as claimed in claim **5**, wherein the cores are made of polypropylene copolymers or polypropylene homopolymers, and the shells are made of polyethylene copolymers, polyethylene homopolymers, polypropylene copolymers or polypropylene homopolymers.

7. The composite board as claimed in claim **5**, wherein the melting temperature of the cores is between 160° C. and 180° C. and the melting temperature of the shells is between 120° C. and 140° C.

8. The composite board as claimed in claim **6**, wherein the melting temperature of the cores is between 160° C. and 180° C. and the melting temperature of the shells is between 120° C. and 140° C.

9. A method for manufacturing a composite board, comprising the steps of:

stretching multiple composite fibers to obtain a composite board, wherein the composite fibers are each composed of a core and a shell formed around the core, a melting temperature of the shells is lower than a melting temperature of the cores, and the strength of the shells is higher than the strength of the cores.

10. The method as claimed in claim **9**, wherein the cores are made of polypropylene copolymers or polypropylene homopolymers, and the shells are made of polyethylene copolymers, polyethylene homopolymers, polypropylene copolymers or polypropylene homopolymers.

11. The method as claimed in claim **9**, wherein the melting temperature of the cores is between 160° C. and 180° C. and the melting temperature of the shells is between 120° C. and 140° C.

12. The method as claimed in claim **10**, wherein the melting temperature of the cores is between 160° C. and 180° C. and the melting temperature of the shells is between 120° C. and 140° C.

* * * * *