



(11) **EP 2 422 644 A1**

(12) **EUROPEAN PATENT APPLICATION**

(43) Date of publication:
29.02.2012 Bulletin 2012/09

(51) Int Cl.:
A45D 34/04 (2006.01) A45D 40/26 (2006.01)

(21) Application number: **10305923.4**

(22) Date of filing: **27.08.2010**

(84) Designated Contracting States:
AL AT BE BG CH CY CZ DE DK EE ES FI FR GB GR HR HU IE IS IT LI LT LU LV MC MK MT NL NO PL PT RO SE SI SK SM TR
Designated Extension States:
BA ME RS

(72) Inventor: **Thorez, Gael**
78960 Voisins le Bretonneux (FR)

(74) Representative: **Callon de Lamarck, Jean-Robert et al**
Cabinet Regimbeau
20 rue de Chazelles
75847 Paris cedex 17 (FR)

(71) Applicant: **Albéa Services**
92230 Gennevilliers (FR)

(54) **Product dispenser for dispensing an elongate product strip**

(57) According to the invention there is provided a product dispenser for dispensing an elongate product strip. In an embodiment, the product dispenser comprises a product container for storing the product to be dispensed, the container defining an opening through which the product can exit the container, a product flow regulator and a dispensing cover that overlies the product flow regulator. The product flow regulator is positioned proximate the container opening and comprises a flow passage that is in communication with the product container, the flow passage accommodating the product exiting the container. The product flow regulator terminates in at least one distribution aperture for allowing the product within the flow passage to exit the product flow regulator, the product flow regulator further comprising a reservoir for accommodating the product exiting the product flow regulator. The dispensing cover defines an elongate distribution slit proximate the reservoir of the product flow regulator, for allowing an elongate product strip to be dispensed.

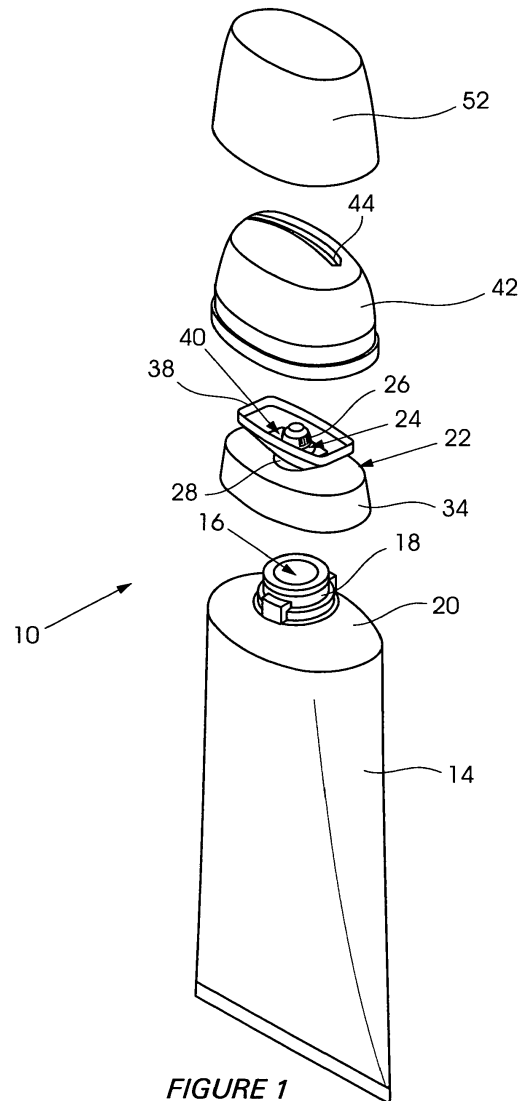

FIGURE 1

EP 2 422 644 A1

Description**FIELD OF THE INVENTION**

[0001] This invention relates to a product dispenser for dispensing an elongate product strip.

BACKGROUND OF THE INVENTION

[0002] Certain products, such as certain skincare creams and lotions, are better applied when they are applied as elongate strips rather than as a single dose that then has to be spread out over the area to be treated using a tool or with fingers. This, for example, would enable the desired area on a person's body to be neatly covered in a single, controlled movement.

[0003] The aim of the present invention is therefore to provide a product dispenser for dispensing an elongate product strip. In particular, the product dispenser aims to allow the even distribution of a strip of product that is uniform both in thickness and in width in a controlled manner.

SUMMARY OF THE INVENTION

[0004] According to the invention there is provided a product dispenser for dispensing an elongate product strip, the product dispenser comprising:

a product container for storing the product to be dispensed, the container defining an opening through which the product can exit the container;

a product flow regulator proximate the container opening, the product flow regulator comprising a flow passage that is in communication with the product container, the flow passage accommodating the product exiting the container, the product flow regulator terminating in at least one distribution aperture for allowing the product within the flow passage to exit the product flow regulator, the product flow regulator further comprising a reservoir for accommodating the product exiting the product flow regulator; and

a dispensing cover overlying the product flow regulator, the dispensing cover defining an elongate distribution slit proximate the reservoir of the product flow regulator, for allowing an elongate product strip to be dispensed.

[0005] In an embodiment, the reservoir is substantially elongate, and is positioned substantially parallel to the elongate distribution slit of the dispensing cover.

[0006] In an embodiment, the product container comprises a spout that defines the container opening, the product flow regulator being securable to the spout of the product container.

[0007] In an embodiment, the product flow regulator comprises:

a conduit that defines the flow passage, the conduit comprising a first, open end snugly fitted within the spout of the product container to receive product exiting the container, and a second end in which the at least one distribution aperture is defined;

a skirt extending from the conduit, proximate the first end of the conduit, the skirt and spout comprising complementary securing formations to enable the skirt, and thus the product flow regulator, to be secured to the spout of the product container; and

a rectangular bowl portion extending from the conduit, proximate the second end of the conduit, the bowl portion defining the reservoir for accommodating the product exiting the product flow regulator through the at least one distribution aperture.

[0008] In an embodiment, the dispensing cover and the skirt comprise complementary securing formations to enable the dispensing cover to be secured to the product flow regulator.

[0009] In an embodiment, proximate the elongate distribution slit, the dispensing cover comprises a rectangular guide wall that can be snugly accommodated within the rectangular bowl portion of the product flow regulator, thereby guiding the flow of product from the reservoir through the elongate distribution slit.

[0010] In an embodiment, the at least one distribution aperture faces sideways or downwards towards the base of the bowl portion, thereby ensuring that the reservoir is filled completely before the product is dispensed through the elongate distribution slit.

[0011] In an embodiment, the product container comprises a flexible wall container such as a tube.

[0012] Alternatively, the product container may comprise a rigid wall container fitted with a dispensing mechanism.

[0013] In an embodiment, the product dispenser is arranged to dispense an elongate product strip having a length of approximately between 2.5 and 3 cm.

[0014] In an embodiment, the product dispenser comprises a cap that is releasably fittable to the dispensing cover.

BRIEF DESCRIPTION OF THE DRAWINGS

[0015]

Figure 1

shows an exploded, perspective view of a product dispenser for dispensing an elongate product strip, according to an example embodiment;

- Figure 2** shows a perspective view of the product dispenser shown in Figure 1 in an assembled configuration, except for a cap that is shown separated from the product dispenser;
- Figure 3** shows a perspective view of the product dispenser in use, namely dispensing an elongate product strip;
- Figures 4 and 5** show side-by-side, exploded, cross-sectional side and front views, respectively, of an upper portion of the product dispenser of the invention;
- Figures 6 and 7** show assembled, cross-sectional side and front views, respectively, of an upper portion of the product dispenser of the invention;
- Figures 8 and 9** show assembled, cross-sectional side and front views, respectively, of the product dispenser of the invention; and
- Figures 10 to 16** show perspective views of alternative embodiments of the product dispenser of the invention.

DESCRIPTION OF PREFERRED EMBODIMENTS

[0016] Referring first to Figures 1 to 9, a product dispenser 10 for dispensing an elongate product strip 12, as best shown in Figure 3, is shown. The product dispenser 10 comprises a product container 14 for storing the product to be dispensed, with the container 14 defining an opening 16 through which the product 12 can exit the container 14.

[0017] In an embodiment, the product container 14 terminates in a spout 18 that projects from a shoulder portion 20 of the product container 14, the spout defining the container opening 16.

[0018] In the illustrated embodiment, the product container 14 comprises a flexible wall container such as a tube. Alternatively, however, the product container 14 may comprise a rigid wall container fitted with a dispensing mechanism to dispense the product within the container 14.

[0019] As best shown in Figures 1 and 4 to 9, the product dispenser 10 further comprises a product flow regulator 22 that can be secured to the product container 14, and in particular to the spout 18 of the container 14, so as to be located proximate the container opening 16. With particular reference to Figures 4 to 7, the product flow regulator 22 comprises a flow passage 24 that is in communication with the product container 14. The flow pas-

sage 24 accommodates the product 12 exiting the container 14, with the product flow regulator 22 terminating in a plurality of central distribution apertures 26 for allowing the product 12 within the flow passage 24 to exit the product flow regulator 22.

[0020] In particular, the product flow regulator 22 comprises a conduit 28 that defines the flow passage 24. The conduit 28, in turn, comprises a first, open end 30 snugly fitted within the spout 18 of the product container 14 to receive product exiting the container 14, and a second end 32 in which the distribution apertures 26 are defined.

[0021] A skirt 34 extends from the conduit 28, proximate the first end 30 of the conduit 28. The skirt 34 and spout 18 comprise complementary securing snap fit formations 36 to enable the skirt 34, and thus the product flow regulator 22, to be secured to the spout 18 of the product container 14.

[0022] A rectangular bowl portion 38 extends from the conduit 28, proximate the second end 32 of the conduit 28. The bowl portion 38 defines a reservoir 40 for accommodating the product 12 exiting the product flow regulator 22 through the distribution apertures 26.

[0023] The product dispenser 10 further comprises a dispensing cover 42 that overlies the product flow regulator 22. The dispensing cover 42 defines a central elongate distribution slit 44 proximate the reservoir 40 of the product flow regulator 22. This arrangement allows an elongate product strip 12 to be dispensed, as best shown in Figure 3.

[0024] In an embodiment, the elongate distribution slit 44 is defined within an elongate recess 46 defined in the dispensing cover 42. Conveniently, the reservoir 40 is substantially elongate, and is positioned substantially parallel to the elongate distribution slit 44 of the dispensing cover 42. This arrangement allows product to flow and accumulate into the reservoir 40 in a controlled manner. In particular, the product flow regulator 22 controls the flow of product towards the slit 44, and the shape and positioning of the distribution slit 44 relative to the reservoir 40 (i.e. that they are essentially parallel to each other) further controls and regulates the dispensing of the product 12.

[0025] In particular, the pattern of product flow creates a pressure gradient in the reservoir 40, which allows the reservoir 40 to fill completely before the product is dispensed through the slit 44. As the product enters the reservoir 40, it will accumulate around the distribution apertures 26 in regions of relatively high product pressure, but eventually, as the product 12 moves to regions within the reservoir 40 of relatively lower pressure, it will distribute evenly in the reservoir 40 before exiting through the slit 44. Advantageously, in this regard, the apertures 26 face sideways or downwards towards the base of the bowl portion 38, and not upwards towards the slit 44. This arrangement ensures that the reservoir 40 is filled completely before the product is dispensed through the slit 44. The result is that the pressure becomes essentially even across the entire length of the slit 44, thereby en-

sureing an even flow of an essentially constant rate of product. As a user of the product dispenser 10 draws the device across the portion of the body to be treated, an elongate strip of product is hence formed. An essentially constant pressure, and hence constant flow rate along the length of the slit 44, leads to the formation of a strip 12 of essentially uniform thickness.

[0026] The thickness of the dispensed product strip 12 also depends upon the pressure applied by the user to the product container 14 (either directly in the case of the container 14 taking the form of a flexible tube or via the dispensing mechanism in the case of the container 24 taking the form of a rigid wall container). A further factor affecting the thickness of the dispensed product strip 12 is the viscosity of the product 12. Thus, to summarise, the thickness of the strip 12 is defined by the speed at which the user draws the product dispenser 10 over the zone to be treated, the pressure applied by the user to the product container 14, and the viscosity of the product 12. Thus, for example, for a given applied pressure and viscosity, the slower the movement of the product dispenser 10 the thicker the strip, and *vice versa*. Similarly, for a given speed of movement and viscosity, the greater the applied pressure to the container 14, the thicker the strip, and *vice versa*. However, the strip width is defined by the geometry of the slit 44, which remains constant irrespective of the pressure applied or the speed of movement defined by the user.

[0027] In an embodiment, the dispensing cover 42 and the skirt 34 comprise complementary securing snap fit formations 48 to enable the dispensing cover 42 to be secured to the product flow regulator 22.

[0028] Proximate the elongate distribution slit 44, the dispensing cover 42 comprises a rectangular guide wall 50 that can be snugly accommodated within the rectangular bowl portion 38 of the product flow regulator 22, as best shown in Figures 6 to 9, thereby guiding the flow of product 12 from the reservoir 40 through the elongate distribution slit 44.

[0029] A cap 52 may be provided that is releasably fittable to the dispensing cover 42, again typically using snap fit formations 54.

[0030] In an embodiment, the product dispenser 10 is arranged to dispense an elongate product strip 12 having a length of approximately between 2.5 and 3 cm, with the product typically having a viscosity of between 83 100 to 155 700 mPA.s and a restitution rate of between 90%-96% (but this does depend on the product's viscosity).

[0031] Turning now to Figures 10 to 16, alternative embodiments of the product dispenser of the invention. For example, the elongate distribution slit 44 may be relatively wide (as indicated by numeral 44.1 in Figure 10) or relatively narrow (as indicated by numeral 44.2 in Figure 11). In one version, the distribution slit 44, although elongate, may be wavy, as indicated by numeral 44.3 in Figure 12. In addition, the slit 44 may be defined off-centre to facilitate application of the dispensed product,

as shown in Figures 13 and 14, with Figure 13 showing a relatively wider slit 44.4 and Figure 14 a relatively narrower slit 44.5.

[0032] The present invention thus provides a product dispenser for dispensing an elongate product strip in a controlled manner and having an even distribution of product.

10 Claims

1. A product dispenser for dispensing an elongate product strip, the product dispenser comprising:

15 a product container for storing the product to be dispensed, the container defining an opening through which the product can exit the container; a product flow regulator proximate the container opening, the product flow regulator comprising a flow passage that is in communication with the product container, the flow passage accommodating the product exiting the container, the product flow regulator terminating in at least one distribution aperture for allowing the product within the flow passage to exit the product flow regulator, the product flow regulator further comprising a reservoir for accommodating the product exiting the product flow regulator; and a dispensing cover overlying the product flow regulator, the dispensing cover defining an elongate distribution slit proximate the reservoir of the product flow regulator, for allowing an elongate product strip to be dispensed.

2. The product dispenser of claim 1, wherein the reservoir is substantially elongate, and is positioned substantially parallel to the elongate distribution slit of the dispensing cover.

3. The product dispenser of either claim 1 or claim 2, wherein the product container comprises a spout that defines the container opening, the product flow regulator being securable to the spout of the product container.

4. The product dispenser of claim 3, wherein the product flow regulator comprises:

50 a conduit that defines the flow passage, the conduit comprising a first, open end snugly fitted within the spout of the product container to receive product exiting the container, and a second end in which the at least one distribution aperture is defined;

55 a skirt extending from the conduit, proximate the first end of the conduit, the skirt and spout comprising complementary securing formations to enable the skirt, and thus the product flow reg-

ulator, to be secured to the spout of the product container; and
 a rectangular bowl portion extending from the conduit, proximate the second end of the conduit, the bowl portion defining the reservoir for accommodating the product exiting the product flow regulator through the at least one distribution aperture.

5

5. The product dispenser of claim 4, wherein the dispensing cover and the skirt comprise complementary securing formations to enable the dispensing cover to be secured to the product flow regulator. 10
6. The product dispenser of claim 5, wherein proximate the elongate distribution slit, the dispensing cover comprises a rectangular guide wall that can be snugly accommodated within the rectangular bowl portion of the product flow regulator, thereby guiding the flow of product from the reservoir through the elongate distribution slit. 15
20
7. The product dispenser of any one of claims 4 to 6, wherein the at least one distribution aperture face sideways or downwards towards the base of the bowl portion, thereby ensuring that the reservoir is filled completely before the product is dispensed through the elongate distribution slit. 25
8. The product dispenser of any one of the preceding claims, wherein the product container comprises a flexible wall container such as a tube. 30
9. The product dispenser of any one of the preceding claims 1 to 7, wherein the product container may comprise a rigid wall container fitted with a dispensing mechanism. 35
10. The product dispenser of any one of the preceding claims, wherein the product dispenser is arranged to dispense an elongate product strip having a length of approximately between 2.5 and 3 cm. 40
11. The product dispenser of any one of the preceding claims, wherein the product dispenser comprises a cap that is releasably fittable to the dispensing cover. 45

50

55

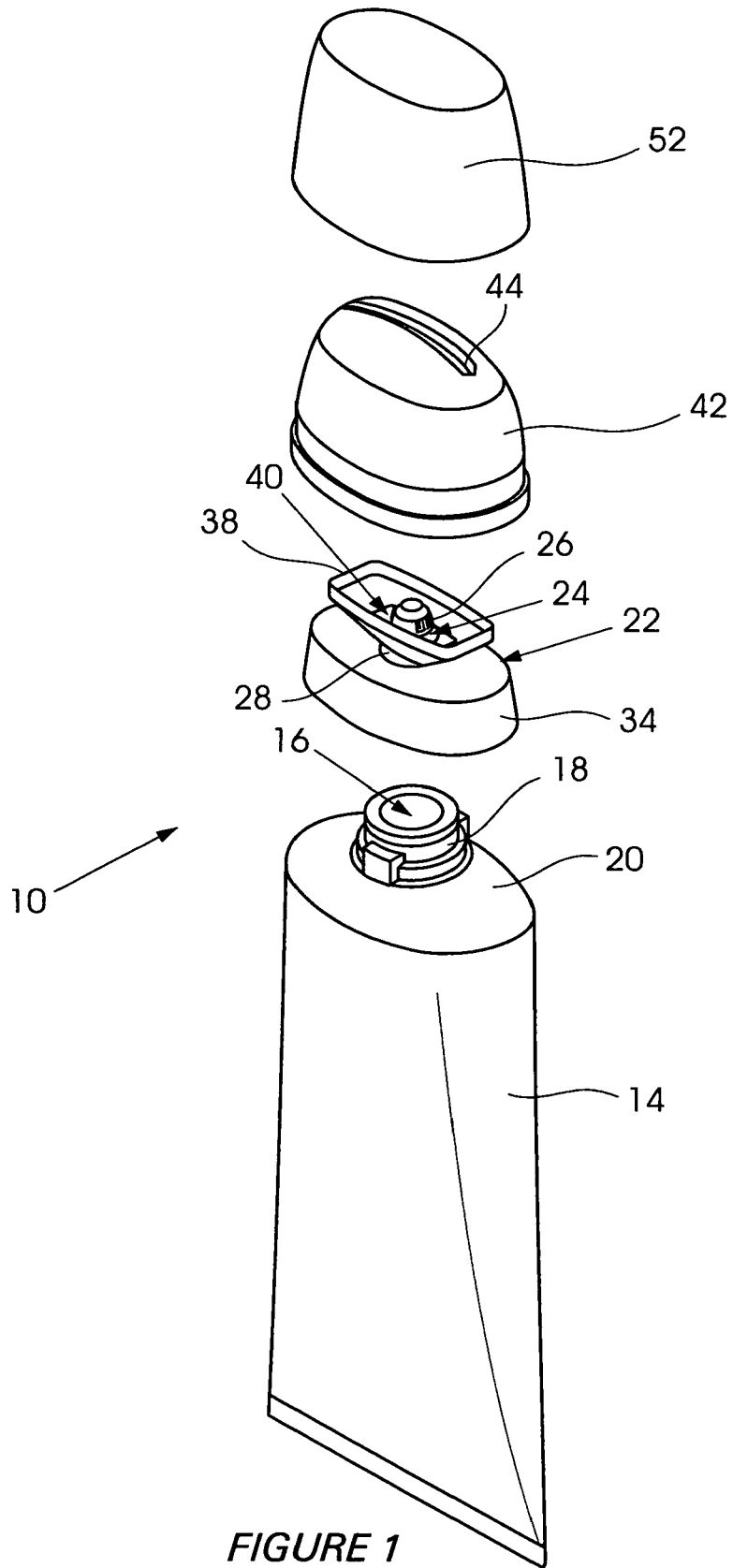

FIGURE 1

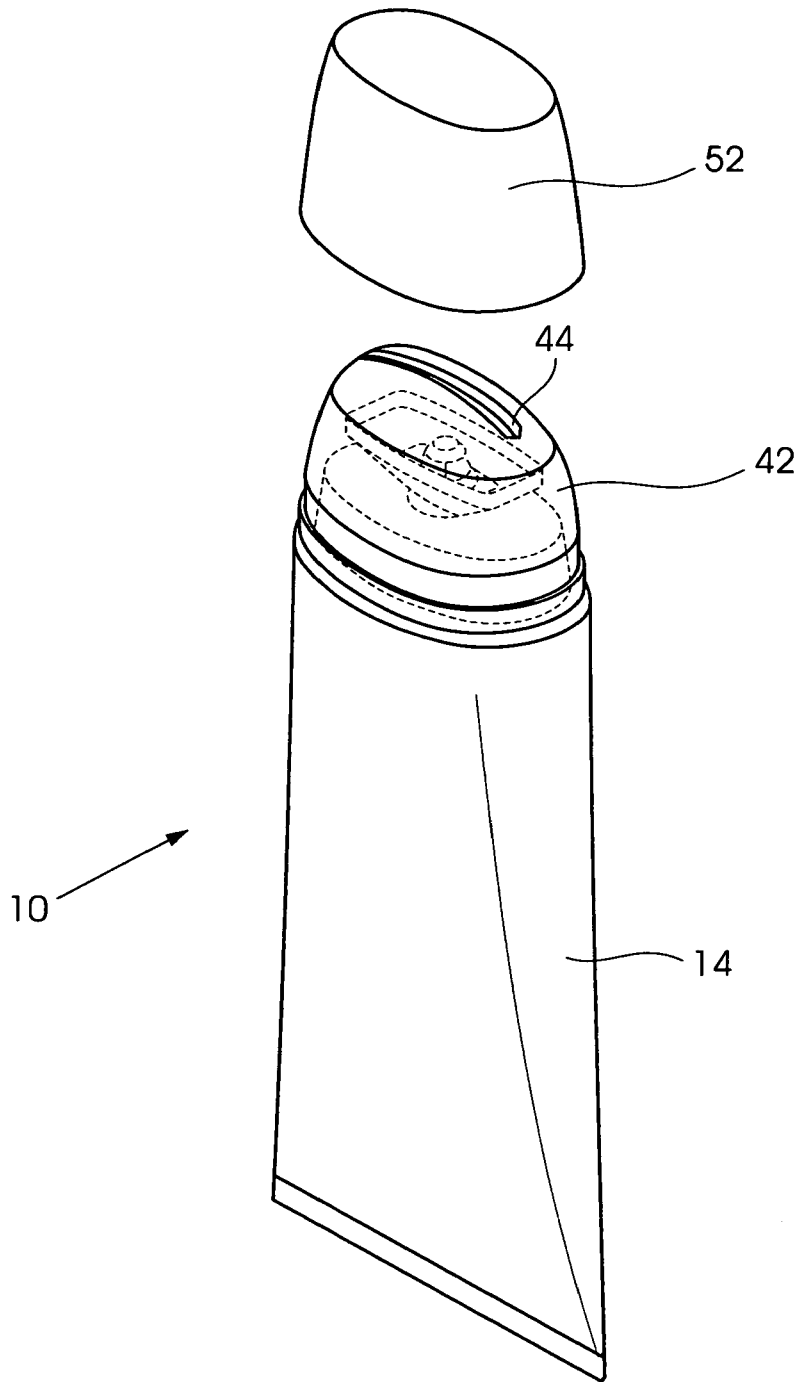

FIGURE 2

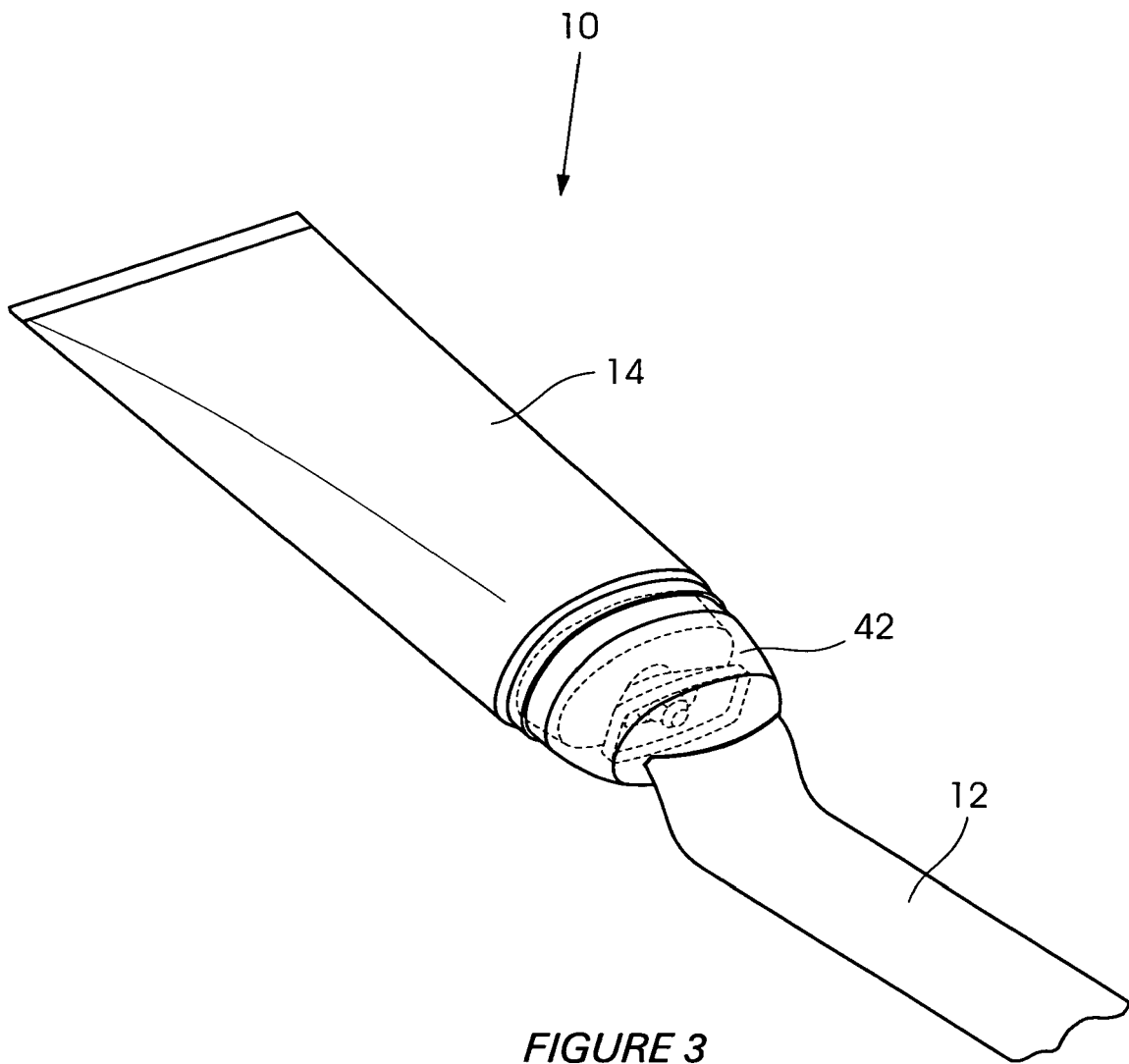

FIGURE 3

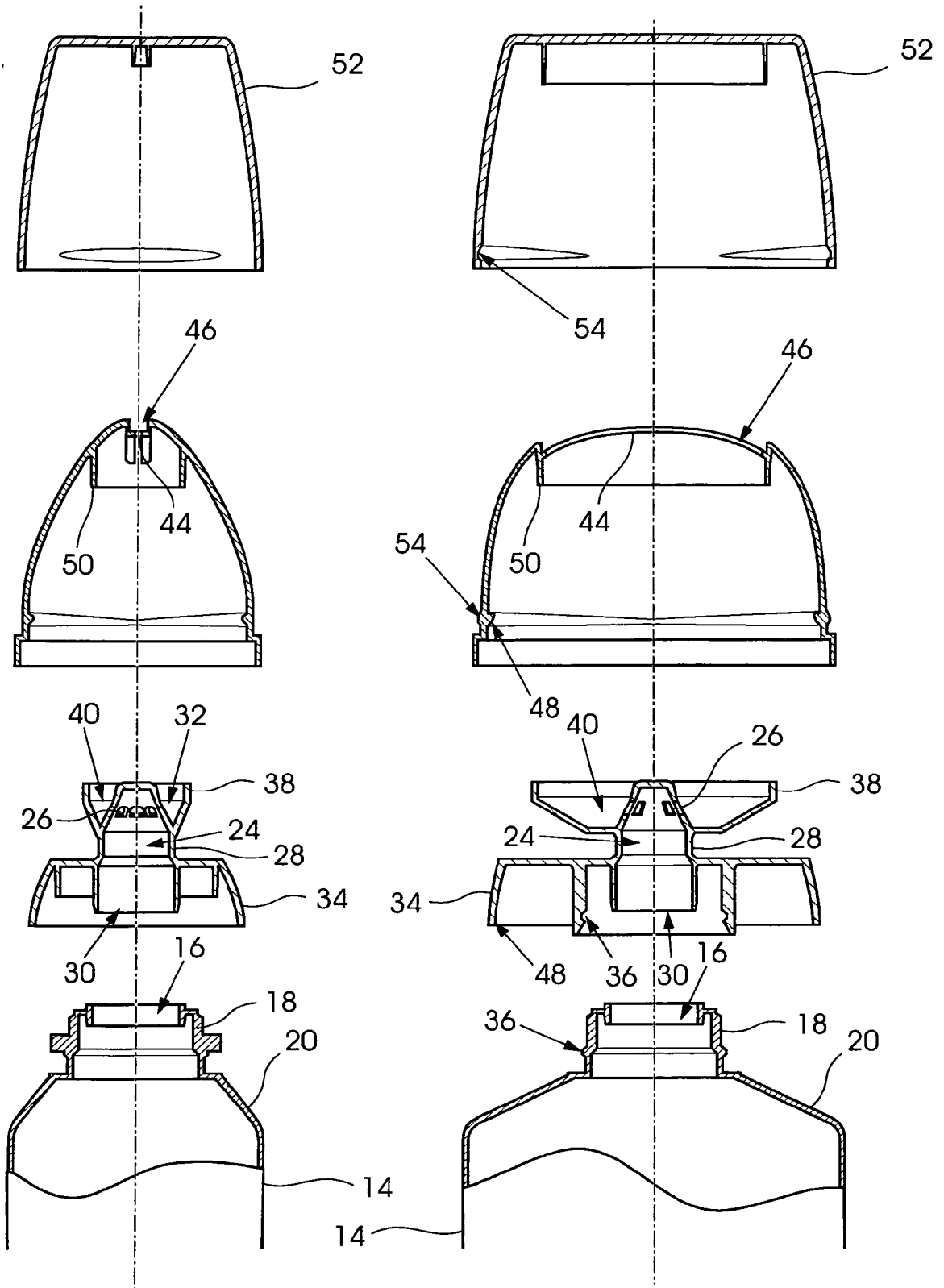

FIGURE 4

FIGURE 5

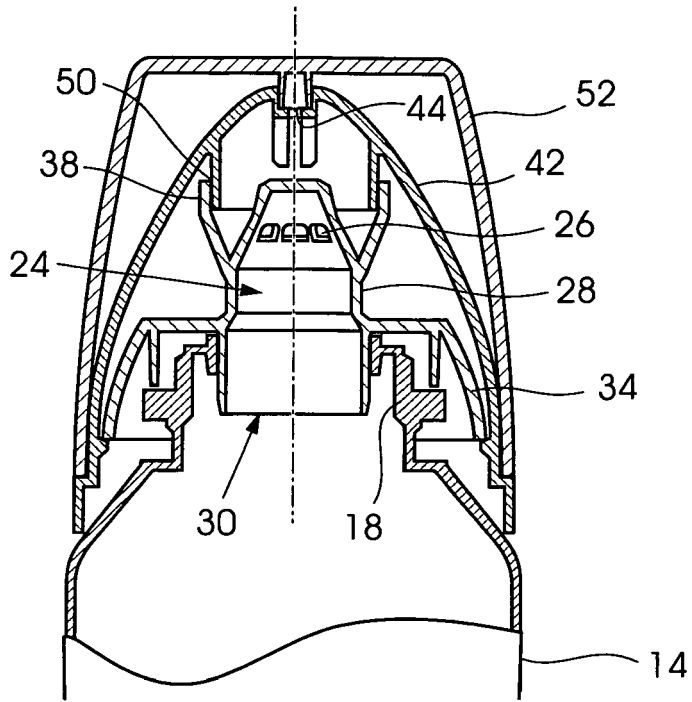

FIGURE 6

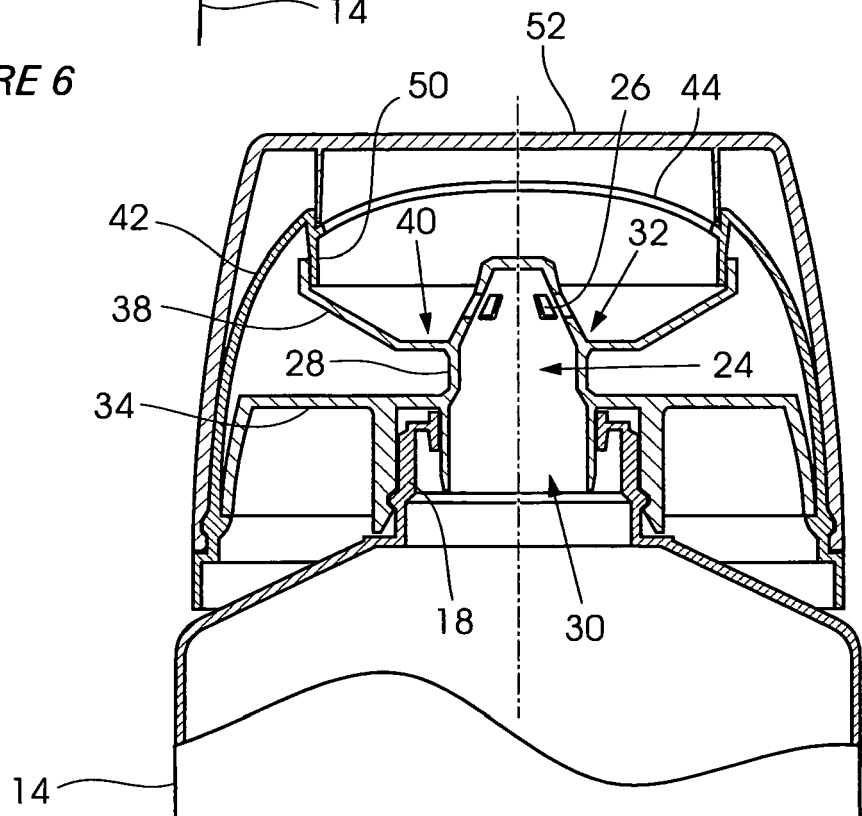

FIGURE 7

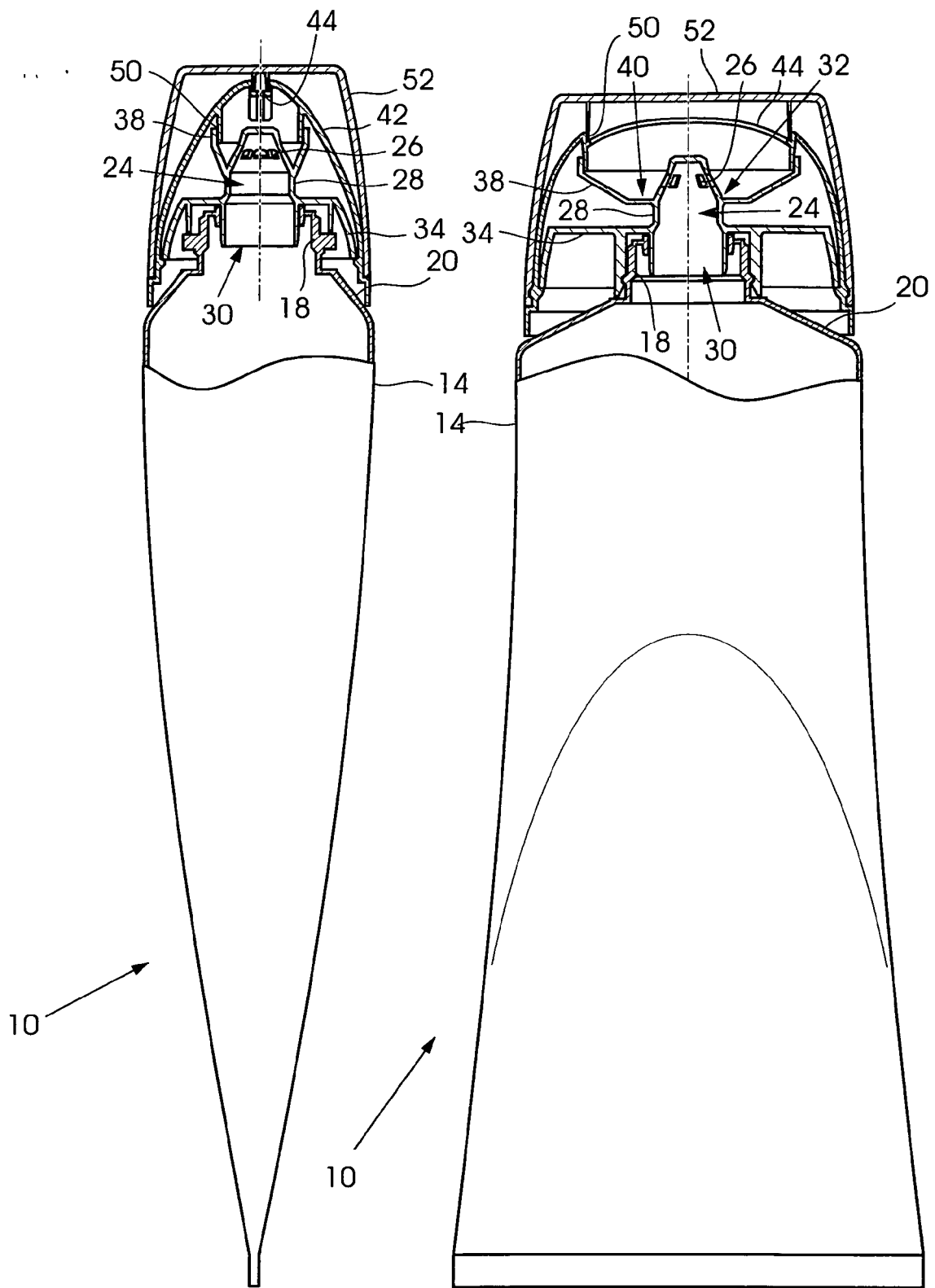

FIGURE 8

FIGURE 9

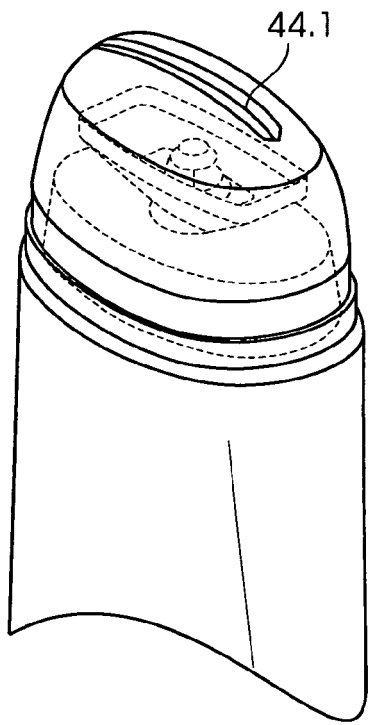

FIGURE 10

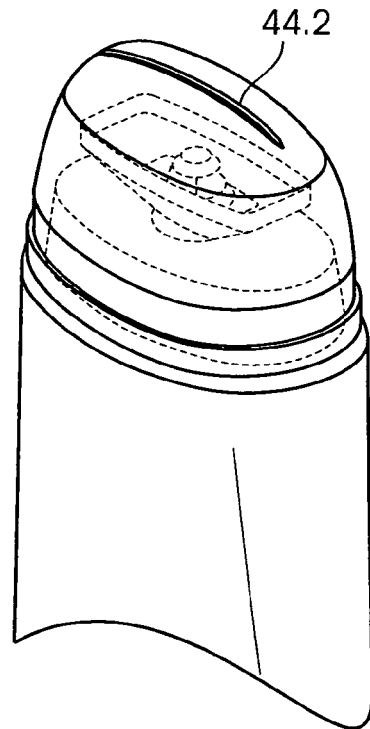

FIGURE 11

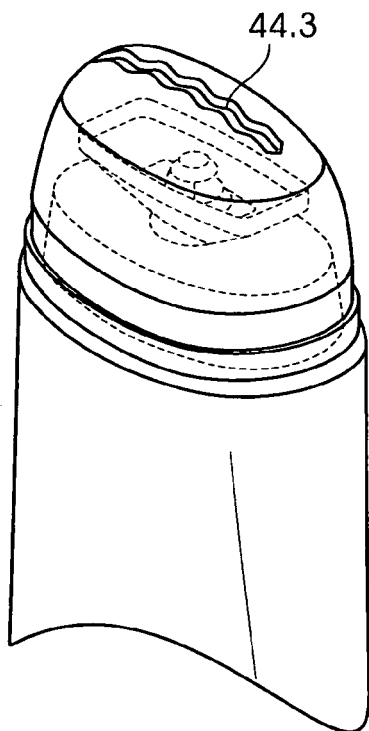

FIGURE 12

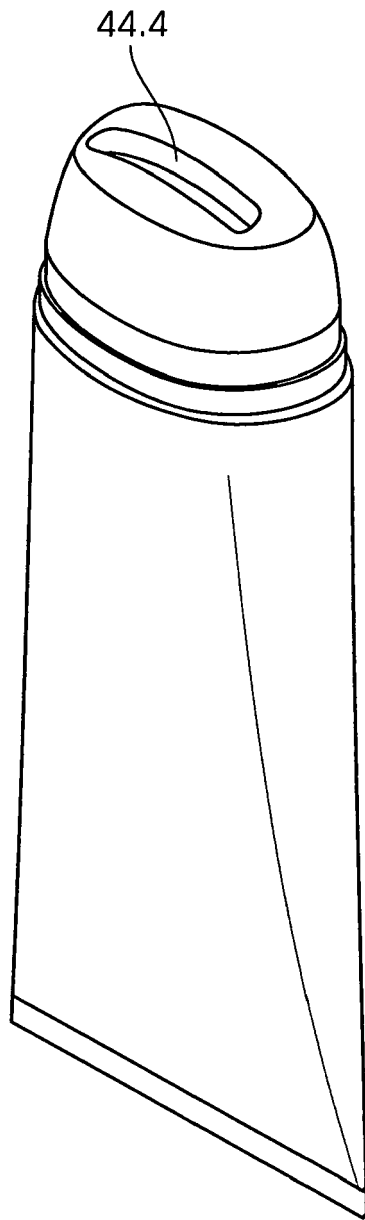

FIGURE 13

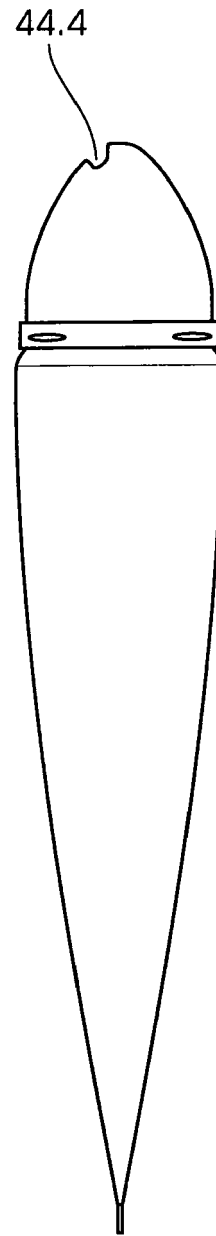

FIGURE 14

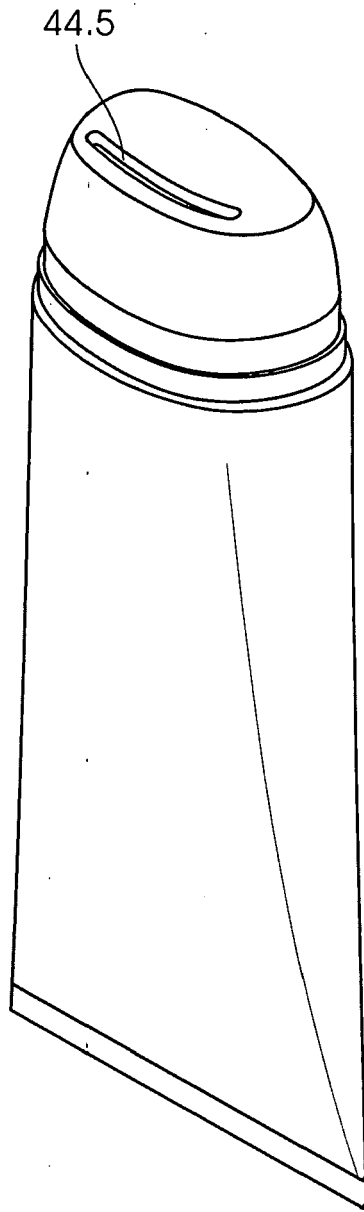

FIGURE 15

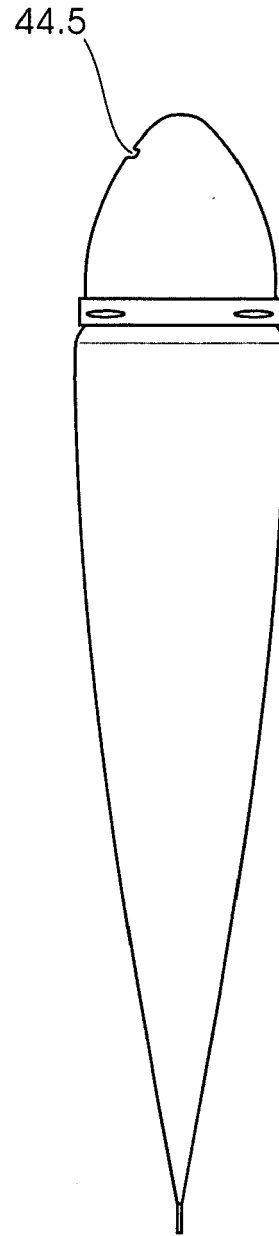

FIGURE 16



EUROPEAN SEARCH REPORT

Application Number
EP 10 30 5923

DOCUMENTS CONSIDERED TO BE RELEVANT			
Category	Citation of document with indication, where appropriate, of relevant passages	Relevant to claim	CLASSIFICATION OF THE APPLICATION (IPC)
X	WO 2010/046921 A2 (PATIL SAGAR SURESH [IN]) 29 April 2010 (2010-04-29) * page 5, line 2 - page 6, line 25; figures 1,3a,3b,4a,4b *	1-11	INV. A45D34/04 A45D40/26
X	US 4 941 598 A (LAMBELET JR LAWRENCE E [US] ET AL) 17 July 1990 (1990-07-17) * column 3, line 16 - column 4, line 64; figures 1-7 *	1-11	
X	US 2 942 762 A (MORRIS FAHR) 28 June 1960 (1960-06-28) * column 2, line 35 - column 3, line 48; figures 1-8 *	1-11	
X	US 4 749 108 A (DORNSBUSCH ARTHUR H [US] ET AL) 7 June 1988 (1988-06-07) * column 1, lines 24-30 * * column 4, line 4 - column 5, line 28 * * figures 1-5,11 *	1-3,8-11	
			TECHNICAL FIELDS SEARCHED (IPC)
			A45D
The present search report has been drawn up for all claims			
Place of search The Hague		Date of completion of the search 10 December 2010	Examiner Mecking, Nikolai
CATEGORY OF CITED DOCUMENTS X : particularly relevant if taken alone Y : particularly relevant if combined with another document of the same category A : technological background O : non-written disclosure P : intermediate document		T : theory or principle underlying the invention E : earlier patent document, but published on, or after the filing date D : document cited in the application L : document cited for other reasons & : member of the same patent family, corresponding document	

3
EPO FORM 1503 03.02 (P04C01)

ANNEX TO THE EUROPEAN SEARCH REPORT
ON EUROPEAN PATENT APPLICATION NO.

EP 10 30 5923

This annex lists the patent family members relating to the patent documents cited in the above-mentioned European search report. The members are as contained in the European Patent Office EDP file on The European Patent Office is in no way liable for these particulars which are merely given for the purpose of information.

10-12-2010

Patent document cited in search report	Publication date	Patent family member(s)	Publication date
WO 2010046921	A2	29-04-2010	NONE
US 4941598	A	17-07-1990	AR 244629 A1 30-11-1993
		AU 626969 B2 13-08-1992	
		AU 4803190 A 28-05-1990	
		BR 8907161 A 26-02-1991	
		CA 2002519 A1 08-05-1990	
		CN 1042877 A 13-06-1990	
		DE 68913036 D1 24-03-1994	
		DE 68913036 T2 26-05-1994	
		DK 164190 A 06-07-1990	
		EP 0395754 A1 07-11-1990	
		ES 2017328 A6 16-01-1991	
		FI 94943 B 15-08-1995	
		GR 89100740 A 31-12-1990	
		HU 56033 A2 29-07-1991	
		IE 66017 B1 29-11-1995	
		IL 92246 A 18-08-1992	
		JP 3502193 T 23-05-1991	
		MX 169637 B 15-07-1993	
		NO 902950 A 02-07-1990	
		NZ 231331 A 28-04-1992	
		PH 26326 A 29-04-1992	
		PT 92239 A 31-05-1990	
		WO 9005091 A1 17-05-1990	
		ZA 8908516 A 31-07-1991	
US 2942762	A	28-06-1960	NONE
US 4749108	A	07-06-1988	AU 589881 B2 19-10-1989
		AU 8280887 A 23-06-1988	
		CA 1283085 C 16-04-1991	
		DE 3780441 D1 20-08-1992	
		DE 3780441 T2 17-12-1992	
		DK 662387 A 20-06-1988	
		EP 0278125 A2 17-08-1988	
		ES 2033302 T3 16-03-1993	
		FI 875520 A 20-06-1988	
		GR 3005936 T3 07-06-1993	
		IE 60519 B1 27-07-1994	
		JP 1935882 C 26-05-1995	
		JP 6059900 B 10-08-1994	
		JP 63248662 A 14-10-1988	
		MX 166267 B 28-12-1992	
		NZ 222988 A 28-06-1989	

EPO FORM P0459

For more details about this annex : see Official Journal of the European Patent Office, No. 12/82