

(43) Date of A Publication 28.02.2001

(21) Application No 0006401.4
(22) Date of Filing 16.03.2000
(30) Priority Data
(31) 19940280 (32) 26.08.1999 (33) DE

(71) Applicant(s)
Dräger Sicherheitstechnik GmbH
(Incorporated in the Federal Republic of Germany)
Revalstrasse 1, D-23560 Lubeck,
Federal Republic of Germany
(72) Inventor(s)
Ralf Stolle
Hartmut Stark
(74) Agent and/or Address for Service
Hasetine Lake & Co
Imperial House, 15-19 Kingsway, LONDON,
WC2B 6UD, United Kingdom

(51) INT CL⁷
G01N 21/31
(52) UK CL (Edition S)
G1A AA4 ADJA AG13 AG16 AG17 AG8 AR6 AR7 AT1
AT20
(56) Documents Cited
GB 2274163 A GB 2057121 A US 5371367 A
(58) Field of Search
UK CL (Edition R) **G1A ABAG ABGX ACDD ACDG**
ADJA ADJX AT1
INT CL⁷ **G01N 21/27 21/31 21/33 21/35 21/59**
ONLINE: WPI EPODOC PAJ

(54) Abstract Title
Gas sensor with an open optical measuring path

(57) Between a light source unit (1) and detector unit (2) extends an optical measuring path (13). The light source unit is provided with a receiver device (9), and the detector unit is provided with a corresponding transmitter device (10) each connected to controlling and evaluating devices (11 and 6), enabling a direct exchange of data between both units and automatic alignment of the source and detector. A further pair of transmitter (7) and receiver (8) enables a bidirectional data exchange. A light source (3) sends a beam of measuring light to a detector (4) via optical guide elements. When the source and detector are aligned with the measuring light beam, the detector registers the intensity of light, and a processing device (12), such as a preamplifier, allows a control and evaluating device (11) to determine the concentration of the gas investigated.

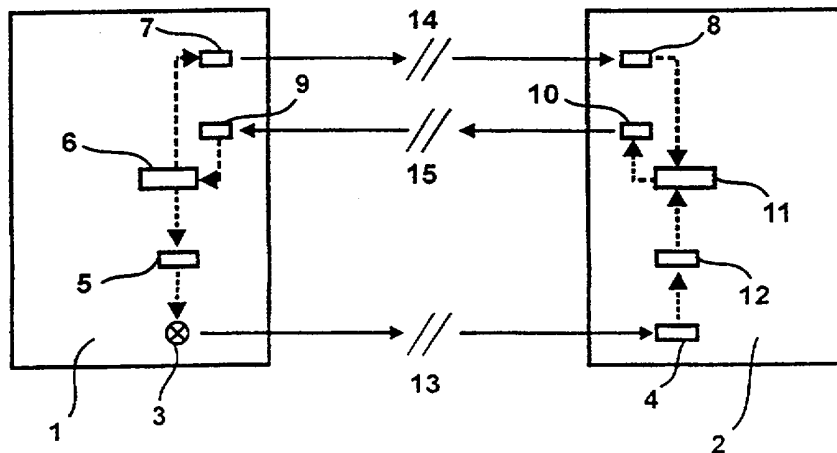

Figure 1

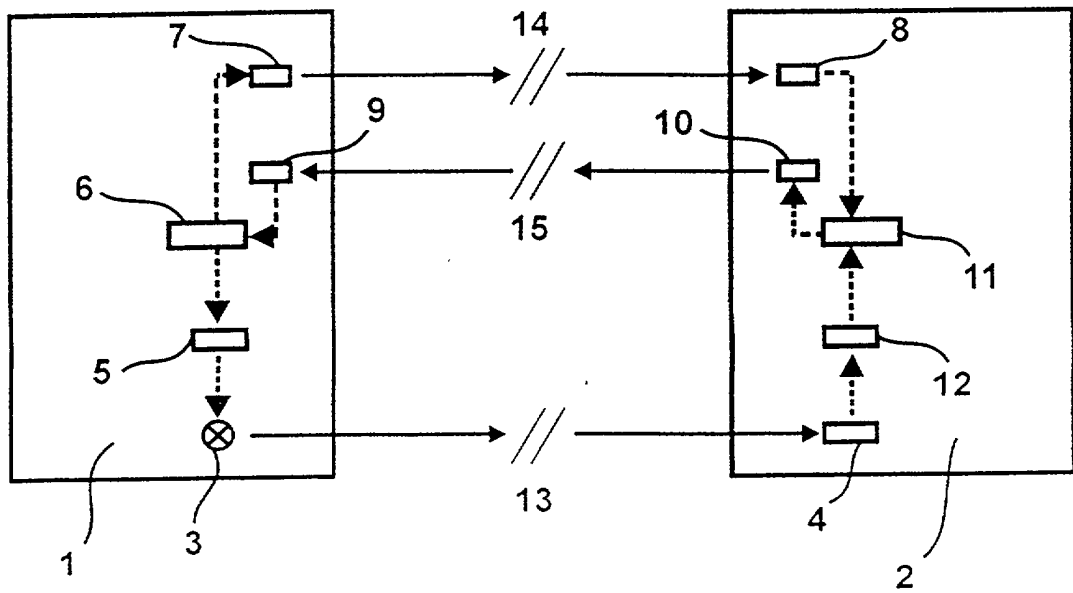

Figure 1

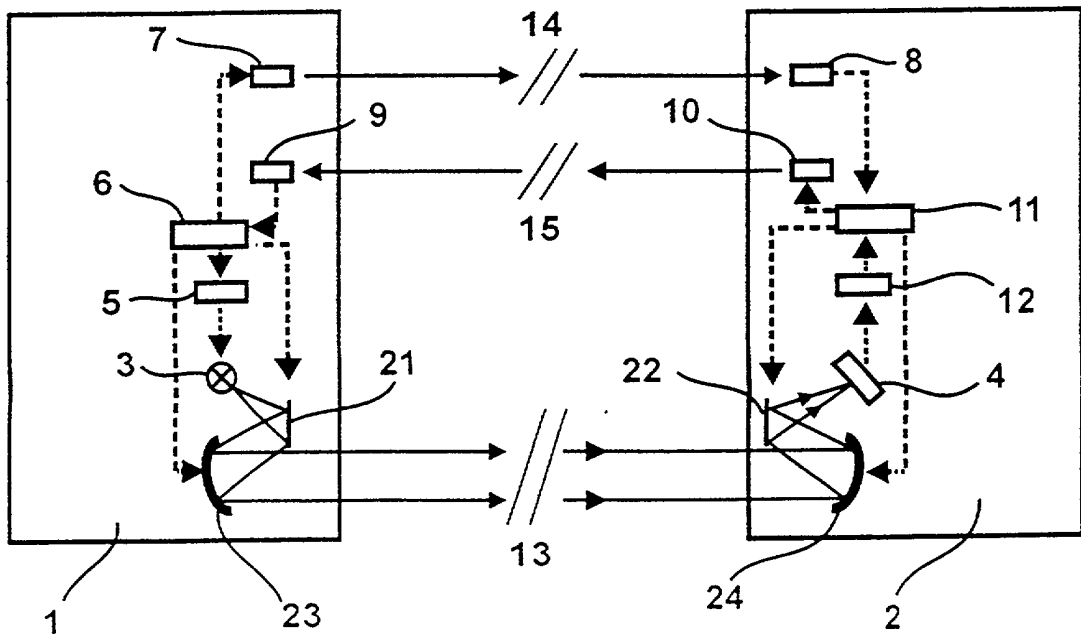
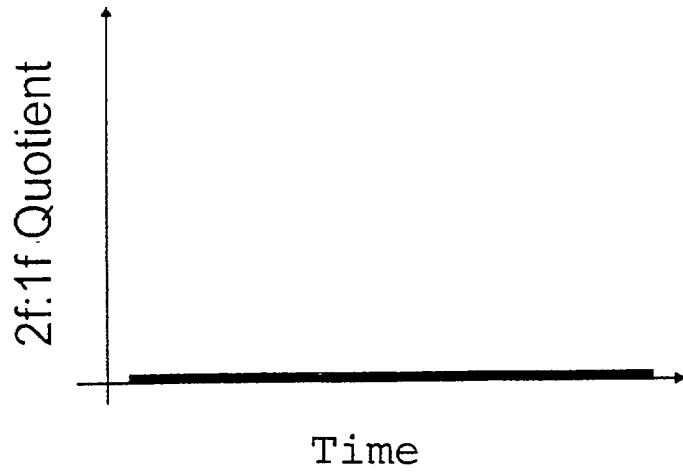
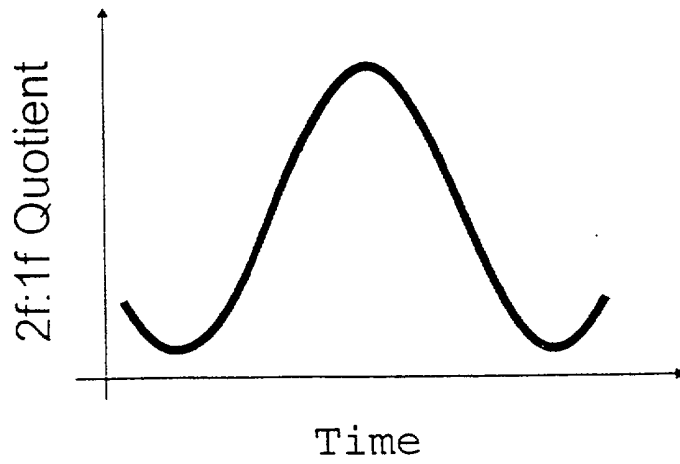

Figure 2



(a)



(b)

Figure 3 (a, b)

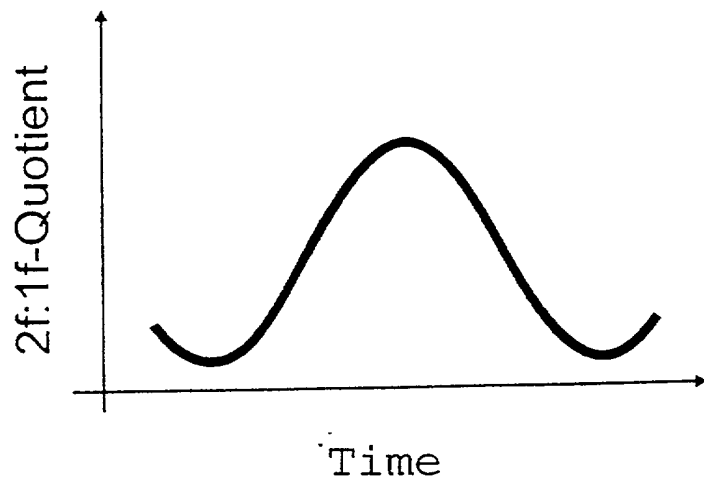

(c)

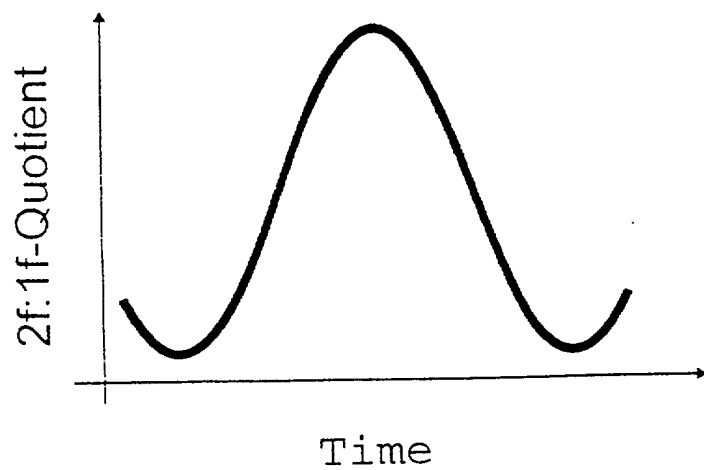

(d)

Figure 3 (c, d)

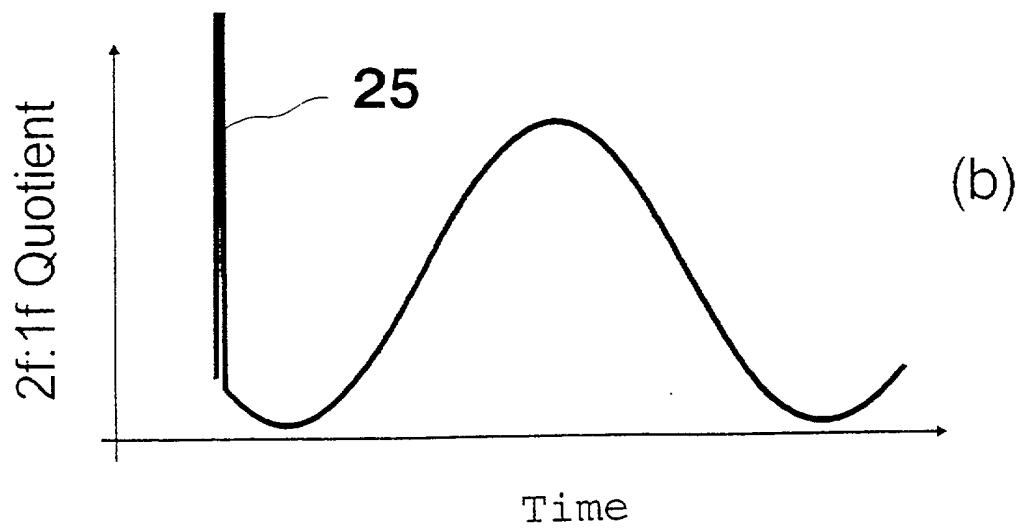
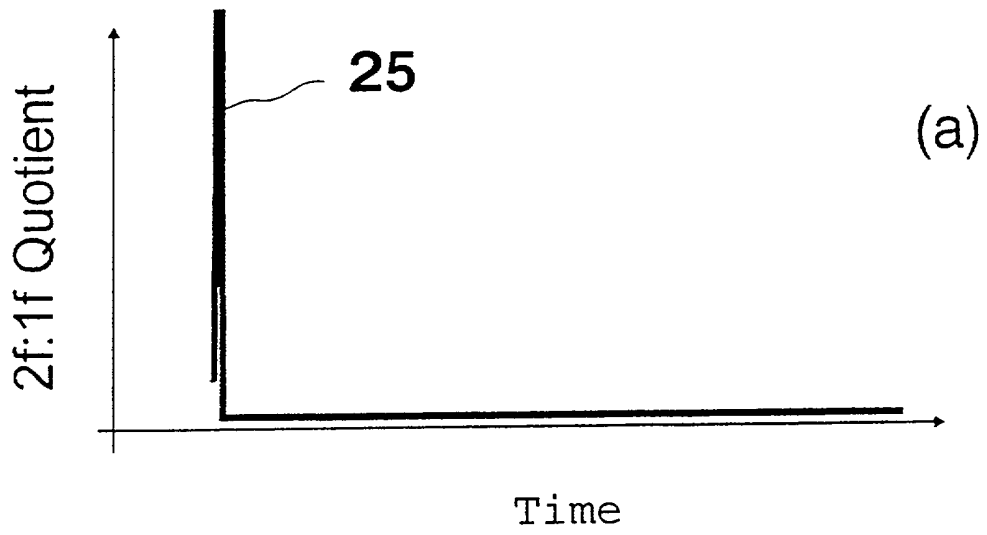

Figure 4

Gas sensor with an open optical measuring path

5 The invention relates to a gas sensor with an open optical measuring path.

Such a device is known from US Patent 5,591,975, for example, wherein a device is described for measuring
10 the exhaust gases of passing automobiles. With this device the vehicles traverse the measuring path which is limited by a light source on one side and an array of photodiodes on the other side.

15 The analysis of gaseous mixtures has acquired increasing importance in environmental analytical chemistry and in industrial monitoring technology. For this reason there is mounting interest in the development of novel gas sensors that are optimised
20 with respect to their sensitivity, selectivity, durability and ease of handling.

Besides gas sensors that monitor a spatially narrowly delimited area, gas sensors that inspect a larger area
25 have recently been employed on an increasing scale. These gas sensors with an open optical measuring path (so-called open-path sensors) register the mean concentration of the target gas over a measuring path having a length ranging from 10 m to a few hundred
30 metres.

In US Patent No. 5,339,155 a device is described in which the light of a light source is modified in its wavelength and this frequency modulation is converted
35 in the presence of the target gas into an amplitude modulation which can be measured by a detector. The measuring path is limited by a light-source unit and a

detector unit, which are spatially separated from one another.

5 As light sources, use has increasingly been made of laser light sources in recent years. In particular, DFB laser diodes are distinguished in that, on the one hand, the wavelength of the emitted light is very much narrower in bandwidth than the absorption lines of gases and, on the other hand, this wavelength can be
10 varied both via the temperature of the laser diode and via the driving laser-diode current.

So-called derivative spectroscopy finds application in many laser-diode-based systems. In this case the
15 wavelength of the laser diode is firstly set in such a way, for example by presetting the laser-diode temperature, that the very narrow-band laser line lies spectrally within the absorption of, for example, an individual gas line of the target gas. Monitoring of
20 the laser-diode temperature may be undertaken, for example, by the laser-diode integrated circuit (chip) being located on a Peltier element which can be brought to a desired temperature by variation of the Peltier current. The laser diode is operated with a
25 current modulation in such a way that the gas line is periodically swept with the frequency f , the modulation preferably being sinusoidal. In this process the laser diode is not only varied in its wavelength but, over and above this, an amplitude
30 modulation of the radiation intensity with the frequency f , the so-called $1f$ -component, also arises as a parasitic effect, it being possible for this amplitude modulation to be drawn upon for normalisation of the intensity.

35

After the measuring path has been passed through, the intensity of the light is detected with a detector that is sensitive to the light of the light source and that generates an electrical signal proportional to the incident light intensity. This detector is equipped with an optical filter which filters out interfering parts of the spectrum, for example the daylight irradiation. In the absence of the target gas, the detector signal is likewise sinusoidal with the frequency f by reason of the corresponding amplitude modulation of the laser-diode current. However, if target gas is present within the measuring path then the intensity that is measured by the detector after the measuring path has been passed through contains components as a function of time that are modulated with the n -fold frequency, so-called n th harmonic components (or also n th harmonics). Generation of these harmonic components is contingent upon the non-linear curve of the absorption line of the gas. These harmonic components of the detector signal can be determined with the aid of appropriate phase-sensitive measuring amplifiers (lock-in amplifiers). Whereas the $1f$ -component of the detector signal is barely influenced by the concentration of the gas, the higher $2f$ -, $3f$ - etc components are approximately proportional to the concentration of the gas. Consequently, for example, the quotient formed from the $2f$ -component and the $1f$ -component, called the $2f:1f$ quotient, represents a normalised numerical value for determining the concentration of the gas, which is independent of external effects such as ageing of the light sources, broadband attenuation by dirt, mist etc.

With a view to compensation of zero-point drifts and with a view to heightening the sensitivities, the

rapid $1f$ -modulation of the laser-diode wavelength is additionally bolstered by a slower modulation of the median wavelength with the frequency F ($f > F$) by the laser-diode current being appropriately varied. This

5 slow modulation may, for example, be effected in the form of a linear tuning ramp (sawtooth); each period of this slow modulation is designated as a "scan". During a scan, a previously defined number of $n \ 2f:1f$ quotients for n different wavelengths are recorded.

10 The amplitudes both of the rapid f -modulation and of the slow F -modulation of the wavelength are each chosen in such a way that they correspond approximately to the width of the gas line. Consequently, instead of the previously described

15 simple value of a $2f:1f$ quotient in the case of a fixed wavelength, a plurality or a multiple of $n \ 2f:1f$ quotients for n different wavelengths are now obtained. With a suitable mathematical evaluation such as, for instance, a PCA process (Principle

20 Components Analysis) or such like, this measured-value multiple can serve both for determining the concentration of the target gas and for reliable identification of the target gas.

25 In order to prevent the originally set temperature of the laser diode or of the Peltier element from changing during operation and consequently to prevent the wavelength of the laser light from varying, on the side of the light-source unit or of the detector unit

30 a beam splitter is provided which steers a portion of the light emerging from the laser diode through a cell (reference cell) in which a gas with suitable absorptive power - for example, the target gas itself - is enclosed. After passing through the reference

35 cell, this portion of the light is detected by a light-sensitive detector. With the aid of a phase-

sensitive measuring amplifier a set of reference measured values, a so-called reference multiple, which is preferably again composed of 2f:1f quotients, can be determined in a manner analogous to that for the measured multiple. By a comparison of this reference multiple with stored values it is possible to detect wavelength drifts and to correct the temperature of the laser diode in such a way that this wavelength drift is precisely compensated.

10

In the case of a large spatial interval between the light-source unit and the detector unit in the course of installation and in operation, gas sensors with an open measuring path can only be handled with difficulty and with great effort. For example, coordination problems arise between the control of the light source and the evaluation of the detector signals in the course of derivative spectroscopy. As far as possible, coordination procedures between the control of the light source and the evaluation in respect of the detector signals have to be performed in a separate controlling and evaluating device which is linked both to the light-source unit and to the detector unit.

25

Such coordination and control problems were avoidable, in part, by virtue of gas-sensor systems in which the light-source unit and the detector unit are arranged in directly adjacent manner and in which a long open measuring path is realised by the light source directing a measuring beam towards a remotely situated retro-reflector, from which the measuring beam is reflected and returned towards the detector unit. Such a gas sensor is known from DE 196 11 290 C2, for example. With this known gas-sensor device the light-source unit and the detector unit are not separated

35

from one another but are accommodated in a housing. This gas sensor has the advantage that the light-source unit and the detector unit can operate in simple manner, attuned to one another. A disadvantage with such gas sensors is the use of a retro-reflector, since as a result of this the signal-to-noise ratio is more unfavourable than in the case of gas sensors in which the measuring light is directed out of the light source directly towards the detector unit.

10

A further problem in the case of gas sensors with open measuring paths of great length consists in the adjustment of the gas sensor. Since the light-source unit and the detector unit may be a few hundred metres apart, in the course of installation and start-up a meticulous optical alignment of both units in relation to one another is firstly necessary. In this connection the following problems arise. On the one hand, the optical guide elements, which serve on sides of the light-source unit and of the detector unit for the purpose of imaging the measuring light onto the detector, are rigidly mounted in the light-source unit and in the detector unit. Consequently, in each instance the light-source unit and the receiver unit have to be moved as a whole, in order to enable an optimal adjustment of the system. If the spacing of light-source unit and detector unit amounts to 100 m, for example, the light-source unit has to be capable of being moved with a precision of $1/20^\circ$ if the measuring light on the side of the detector unit is to be capable of being positioned with a precision of 10 cm. In practice, this precision requirement, together with the typical weight of the light-source unit amounting to several kilograms, constitutes a considerable design problem. On the other hand, during the adjustment of the system no immediate

35

information is available as to how good the instantaneous adjustment is. Accordingly, either with an optical aid such as a telescopic sight, for instance, firstly a coarse adjustment has to be performed and subsequently the detector signal has to be monitored at the detector which is 100 m away, for which purpose either the installation engineer himself has to make his way to the remote detector unit or a second person has to record and monitor the detector signal there. The start-up of a gas sensor with an open measuring path of great length or the monitoring of the adjustment is accordingly possible only with great effort in terms of personnel and time.

Embodiments of the present invention aim to create a more easily manageable and operable gas sensor with an open optical measuring path that can be easily adjusted even in the case of a long measuring path. Furthermore, the measuring light of the light-source unit is to be directed towards the detector unit directly and not via a retro-reflector, in order that a good signal-to-noise ratio can be achieved, and at the same time a simple coordination between detector unit and light-source unit is to be made possible.

Accordingly, the invention provides a gas sensor with an open optical measuring path for the optical measurement of at least one gas component, with a light-source unit, a detector unit, between which the optical measuring path extends, and with a controlling and evaluating device, wherein the light-source unit comprises a light source and optical guide elements for sending out a beam of measuring light to the detector unit and the detector unit contains a detector which, when aligned in the beam path of the beam of measuring light, registers the intensity of

light from the beam of measuring light, wherein the
controlling and evaluating device is arranged in use
to determine, on the basis of the measured signal of
the detector, a measure of the concentration of the
5 gas component to be investigated, and wherein the
detector unit is provided with a transmitter device
which is linked to a controlling and evaluating device
in the detector unit, and the light-source unit is
provided with a receiver device which is linked to a
10 controlling and evaluating device in the light-source
unit, so that a direct exchange of data between
detector unit and light-source unit is made possible.

15 Further, preferred features may be found in the
appended sub-claims, to which reference should now be
made.

In accordance with the invention the detector unit is
20 provided with a transmitter device and the light-
source unit is provided with a receiver device that
responds to the signals of the transmitter device, so
that a direct exchange of data between the detector
unit and the light-source unit is made possible, the
25 transmitter and receiver devices communicating
respectively with controlling and evaluating devices
in the detector unit and in the light-source unit. In
this way it is possible, for example, that an
optimisation of the alignment of light-source unit and
30 detector unit with respect to one another can be
performed in the course of adjustment of the gas
sensor, whereby the light-source unit receives a
feedback message pertaining to the registered detector
signal from the detector unit, so that a scanning
35 search enables an optimisation of the strength of the
detector signal and hence an optimal alignment of the

beam of measuring light towards the detector unit. Such a feedback message can also be used in order to carry out an automatic adjustment of light-source unit and detector unit. For this purpose, mobile optical
5 guide elements (mirrors) that are capable of being driven electrically may be present both in the light-source unit and in the detector unit, which are adjusted by controlling and evaluating devices in such a way as to result in a detector signal that is as
10 strong as possible, and hence an alignment of the detector in the beam path of the beam of measuring light is obtained that is as good as possible.

In an advantageous embodiment, conversely the light-
15 source unit is also equipped with a transmitter device and the detector unit is also equipped with a receiver device that responds to this transmitter device, so that a direct bidirectional exchange of data between light-source unit and detector unit is made possible.
20 The possibility of a bidirectional exchange of data between light-source unit and detector unit has many advantages. For instance, service functions, a calibration of the gas sensor or a self-test can be performed by suitably designed controlling and
25 evaluating devices in the light-source unit and in the detector unit. In particular in connection with the derivative spectroscopy, which was described above, in combination with a laser diode, it is very advantageous metrologically if a bidirectional
30 exchange of data is achieved between light-source unit and detector unit, for example for the modulation of the detector signal or for the purpose of synchronising the controlling and evaluating device in the detector unit with the tuning ramp driving the
35 laser diode, which is monitored by the controlling and evaluating device in the light-source unit.

The transmitter and receiver devices in the light-source unit and in the detector unit may operate in wireless manner or via a cable connection, either via an electrical cable connection or via an optical cable connection. Alternatively it is also possible for the transmitter device in the light-source unit to be realised by a suitable design of the controlling and evaluating device which drives the light source in such a way that the measuring light is modulated in frequency and/or amplitude, in order by means of the measuring light also to transmit data that can be demodulated from the detector signal by a suitably designed controlling and evaluating device in the detector unit.

15

The light source may be an incandescent lamp, a flash lamp, a laser diode or any other light source. In this connection the measuring light is by no means restricted to the range of visible light; in many cases it is advantageous to work outside the range of visible light, for example in the infrared range, in order that interfering effects as a result of background light and sunlight can be eliminated.

25

Preferred embodiments of the present invention will now be described, by way of example only, with reference to the accompanying drawings, in which:

30

Figure 1 shows a schematic block diagram of a light-source unit and a detector unit;

35

Figure 2 shows a modification of the device represented in Figure 1, in which optical guide elements that are electrically adjustable are provided in the light-source unit and in the detector unit;

Figure 3 shows the curve of the $2f:1f$ quotient in the case of a laser-diode-based gas sensor with an open measuring path during a scan under the following conditions: (a) normal
5 operating mode when no target gas is present; (b) normal operating mode when target gas is present; (c) monitoring scan when no target gas is present; (d)
10 monitoring scan when target gas is present;

Figure 4 shows the curve of the $2f:1f$ quotient in the case of a laser-diode-based gas sensor with an open measuring path during a scan with start pulse for the synchronisation of
15 light-source unit and detector unit in the presence (a) and in the absence (b) of the target gas.

Figure 1 shows an embodiment of the invention in which
20 a bidirectional transmission of data between light-source unit 1 and detector unit 2 is provided via two communication channels 14, 15.

The measuring-light source 3 emits the measuring light
25 and is driven by a control circuit 5 which provides the necessary supply parameters such as current, voltage etc to the light source 3 and which in turn is controlled by a controlling and evaluating device 6 in the form of a processor.

30 The measuring light traverses the open measuring path 13 and is registered by a detector 4 in the detector unit 2. The measured signal of the detector 4 is electrically preprocessed in a processing device 12;
35 this preprocessing may consist of a current-voltage conversion, a preamplification, a demodulation, an

analogue-digital conversion etc. The preprocessed signal is finally passed to a controlling and evaluating device 11 in the form of a processor which undertakes the evaluation of the data and, in particular, ascertains the concentration of the target gas in the measuring path 13 from these data.

The communication channels 14 and 15 for the bidirectional exchange of data between light-source unit 1 and detector unit 2 are constituted by a transmitter device 7 in the form of a light source together with drive circuit and a first receiver device 8 in the form of a detector, as well as by a transmitter device 10 in the form of a light source together with drive circuit and a second receiver device 9 in the form of a detector. The exchange of data is controlled by the same controlling and evaluating devices 6 and 11 in the light-source unit 1 and in the detector unit 2 which also, respectively, control the light source 3 and read out and evaluate the detector 4.

Alternatively it is possible, instead of optical transmitter devices 7, 10 and receiver devices 8, 9, to employ appropriate transmitter devices 7, 10 and receiver devices 8, 9 that operate with radio signals.

The embodiment represented in Figure 1 may be employed, for example, in the case of a laser-diode-based gas sensor with an open measuring path that operates by the process of derivative spectroscopy described above. In this connection, suitable data can be sent from the light-source unit 1 to the detector unit 2 that enable a synchronisation of the controlling and evaluating device 11 with the drive of the light source 3 by the controlling and evaluating

device 6, for example a synchronisation with the tuning ramp which brings about the stated slow shift of the median wavelength of the laser light. For example, right at the start of each scan a data flow (start pulse) can be sent from the light-source unit 1 to the detector unit 2 via the communication channel 14, which enables the controlling and evaluating device 11 in the detector unit 2 to be synchronised with the tuning ramp of the drive of the light source 3.

Furthermore, with the embodiment represented in Figure 1 it is possible to transmit data from the detector unit 2 to the light-source unit 1 that provide information about the strength of the optical measuring-light signal received by the detector 4. This information can be used in very advantageous manner in the course of an adjustment of the system, for example in the course of initial start-up, since the technician who aligns the light-source unit 1 or the light source 3 with the detector 4 can thereby receive immediate information about the quality of the adjustment.

In an extension of the embodiment represented in Figure 1 it is possible for the gas sensor to adjust itself automatically if the optical guide elements of the light-source unit 1 and/or of the detector unit 2 are capable of being adjusted by electrical drive, i.e. if the corresponding optical guide elements are provided with an adjusting device that is capable of being driven electrically. Figure 2 shows such an embodiment in which the optical systems pertaining to light-source unit and detector unit 1 and 2 consist respectively of a curved mirror 23, 24 and a plane mirror 21, 22 and in which these four mirrors are all

capable of being adjusted independently of one another.

In the case of the embodiment example according to
5 Figure 2, the start-up of the gas sensor is
substantially simplified, since the optical adjustment
of light-source unit 1 and detector unit 2 can be
performed in such a way that firstly only a coarse
alignment is effected, so that the detector 4
10 generally receives measuring light from the light
source 3. The necessary fine tuning for the purpose
of optimising the optical alignment is then performed
automatically by means of the adjustment of the
mirrors 21, 22, 23, 24 by the gas sensor, by the
15 controlling and evaluating devices 6 and 11 being
appropriately designed so that they can implement
optimising searches which lead to an optimal setting
of the mirrors and hence to an optical measured signal
of the detector 4. Such a fine adjustment may, for
20 example, be carried out in such a way that the mirrors
21, 23 of the light-source unit 1 run through a
previously defined pattern of movement, by virtue of
which the light of the beam of measuring light sweeps
over the detector 4. By virtue of the transmitter
25 device 10 and the receiver device 9, the detector unit
2 is able to communicate to the light-source unit 1,
namely to the controlling and evaluating device 6
thereof, at which moment the received signal was
optimal - that is to say, in which position the
30 greatest intensity, for example, of the detector
signal was measured. The controlling and evaluating
device 6 can then reproduce this position, in order
subsequently, for example, to initiate a second
pattern of movement of the optical guide elements of
35 the light-source unit 1, in order in this way to
approach, in iterative manner, an optimally aligned

position of the optical guide elements of the light-source unit 1. Subsequently, the optical guide elements of the detector unit 2, namely the mirrors 22 and 24, can likewise be automatically adjusted in
5 iterative manner in order to achieve an optical beam path and a maximal measuring-light intensity on the detector 4.

Alternatively it is also possible in each instance to
10 adjust the optical guide elements pertaining to light-source element 1 and/or detector unit 2 as a whole, whereby the relative alignment of the optical guide elements to one another - that is to say, in Figure 2 the alignment of mirror 21 relative to mirror 23 and
15 of mirror 22 relative to mirror 24 - remains unaffected.

With the embodiment shown in Figure 2 it is likewise possible to carry out the described automatic
20 adjustment of the system not only in the course of the initial start-up but also in the case of a maladjustment of the gas sensor during operation, in order that a necessary readjustment can be carried out automatically if need be.

25 In another embodiment it is possible to construct the gas sensor in such a way that additional data are transmitted from the light-source unit 1 to the detector unit 2 with the measuring light itself by the
30 light source 3 being suitably modulated. This possibility can be realised, for example in Figure 1, by the controlling and evaluating device 6 being prepared in such a way that it is able to modulate the light source 3 suitably via the light-source drive 5.
35 In the case of laser-diode-based derivative spectroscopy the data are superimposed on the driving

laser-diode current, and in the laser diode this current modulation is again converted into an amplitude modulation of the measuring light, which can be registered by the detector 4 and decoded and
5 evaluated by the controlling and evaluating device 11.

For instance, in the course of derivative spectroscopy in conjunction with a laser diode it is possible to modulate the measuring light in such a way that the
10 intensity of the laser light at the location of the detector 4 contains *a priori* as a function of time a 2f-component such as would conventionally be generated solely by the presence of the target gas within the measuring path 13. Figures 3 (a) to 3 (d) show
15 schematically the 2f:1f quotient as measured during a scan: in the normal operating mode the laser light is modulated in purely sinusoidal manner with the frequency f , so that in the absence of the target gas the signal received by the detector 4 exhibits no
20 2f:1f component or only a very slight 2f:1f component (see Figure 3(a)). When the target gas is present in the open measuring path 13 a characteristic curve of the 2f:1f quotient arises during a scan, from which the concentration of the gas can be inferred (see
25 Figure 3 (b)). With the possibility of exchanging data between light-source and detector units 1, 2 which is provided in accordance with the invention it is possible to send out a so-called monitoring scan at arbitrary points in time: in this case - in contrast
30 with the normal operating mode - the laser-diode current itself already has a suitable 2f-component applied to it. This 2f-component of the laser-diode current is not constant during a scan but is varied in such a manner that the 2f:1f quotient of the laser-
35 diode current has a form that corresponds, with the exception of a constant factor, to the curve of the

2f:1f quotient from Figure 3 (b). Hence the emitted laser light undergoes, from the start, an amplitude modulation which is so pronounced that the measured signal in the detector unit 2 must be falsely
5 interpreted by the controlling and evaluating device 11 as a gas concentration, even if no target gas was present in the measuring path 13.

Figures 3 (c) and 3 (d) illustrate the monitoring scan. In the absence of the target gas, the measured
10 2f:1f quotient of the detector signal corresponds to the presence of the target gas in a certain concentration (pseudo gas concentration, see Figure 3 (c)). This pseudo gas concentration can be freely
15 chosen beforehand via the scaling of the 2f-component of the laser-diode current. In the presence of the target gas (Figure 3 (d)), the measuring effect due to gas is added to the 2f:1f quotient of the monitoring scan, so that the gas detector measures a
20 concentration overall that corresponds to the sum of the gas concentration and the pseudo gas concentration. By virtue of the possibility, provided by the gas sensor configured in accordance with the invention, of initiating such a monitoring scan at an
25 arbitrary point in time, on the one hand it is possible to examine the measuring readiness of the gas sensor at regular intervals. For this purpose, for example, the condition can be examined whether the gas concentration measured during a monitoring scan is at
30 least as great as the pseudo gas concentration chosen beforehand, since otherwise an operating fault obtains.

Furthermore, the described processing mode with a
35 monitoring scan can be utilised in order to monitor the calibration of the gas sensor. With a view to

calibration it is possible to exploit the fact that the gas concentration measured after the initiation of a monitoring scan has to be as great as the sum of the chosen pseudo gas concentration and the gas

5 concentration that was registered immediately before the initiation of the monitoring scan in the normal operating mode. If this is not the case, a fault of the gas sensor or a faulty calibration obtains.

10 The possibility of transmitting additional data from the light-source unit 1 to the detector unit 2 with the measuring light can be utilised for the purpose of realising the start pulse, described above, for the purpose of synchronisation by a suitable modulation of the measuring light, as represented schematically in

15 Figures 4 (a) and (b). At the start of a scan the light source 3 is driven by the controlling and evaluating device 6 in such a way that a value of the $2f:1f$ quotient that is very high for a short time is generated with a characteristic pulse form 25 which

20 can be identified in the detector signal by the controlling and evaluating device 11 in the detector unit 2 and can be used for the purpose of synchronisation in the course of evaluation of the

25 measured signals.

Claims

1. Gas sensor with an open optical measuring path
for the optical measurement of at least one gas
5 component, with a light-source unit, a detector
unit, between which the optical measuring path
extends, and with a controlling and evaluating
device, wherein the light-source unit comprises a
light source and optical guide elements for
10 sending out a beam of measuring light to the
detector unit and the detector unit contains a
detector which, when aligned in the beam path of
the beam of measuring light, registers the
intensity of light from the beam of measuring
15 light, wherein the controlling and evaluating
device is arranged in use to determine, on the
basis of the measured signal of the detector, a
measure of the concentration of the gas component
to be investigated, and wherein the detector unit
20 is provided with a transmitter device which is
linked to a controlling and evaluating device in
the detector unit, and the light-source unit is
provided with a receiver device which is linked
to a controlling and evaluating device in the
25 light-source unit, so that a direct exchange of
data between detector unit and light-source unit
is made possible.

2. Gas sensor according to Claim 1, wherein the
30 light-source unit is further provided with a
transmitter device which is linked to the
controlling and evaluating device in the light-
source unit, and the detector unit is provided
with a receiver device which is linked to the
35 controlling and evaluating device in the detector
unit, so that a direct bidirectional exchange of

data between detector unit and light-source unit is made possible.

- 5 3. Gas sensor according to Claim 1, wherein the transmitter and receiver devices pertaining to the detector unit and the light-source unit are arranged for wireless transmission of data.
- 10 4. Gas sensor according to Claim 2, wherein both pairs of transmitter and receiver devices in the light-source unit and in the detector unit are arranged for wireless transmission of data.
- 15 5. Gas sensor according to Claim 1, 2 or 3, wherein, with a view to wireless transmission of data, a pair of interacting transmitter and receiver devices comprises a light source and a sensor responding to the light of the light source.
- 20 6. Gas sensor according to Claim 1, 2 or 3, wherein a pair of interacting transmitter and receiver devices are connected by cable.
- 25 7. Gas sensor according to Claim 6, wherein the cable connection comprises an electrically conductive cable or an optical-fibre cable and the transmitter device transmits electrical signals or light signals and the receiver device responds to electrical signals or to light signals.
- 30 8. Gas sensor according to Claim 2, wherein the transmitter device in the light-source unit and the receiver device in the detector unit are realised by the controlling and evaluating device in the light-source unit being arranged in such a
- 35

way that, via a light-source control, it modulates the frequency and/or amplitude of the light emitted from the light source in order to transmit data from the light-source unit to the detector unit, and by the controlling and evaluating device in the detector unit being arranged to demodulate the modulation of the beam of measuring light and thereby to decode the transmitted data.

10

9. Gas sensor according to any of Claims 2 to 8, wherein the optical guide elements in the light-source unit are capable of being adjusted in their alignment by means of an electrical drive, and further optical guide elements are present in the detector unit which are capable of being adjusted in their alignment by means of an electrical drive, and the controlling and evaluating device in the light-source unit and the controlling and evaluating device in the detector unit are arranged to interact in order to perform an optimal optical adjustment automatically by controlling the alignment of the optical guide elements, utilising the transmission of data between the light-source unit and the detector unit.

15

20

25

10. A gas sensor substantially as herein described, with reference to the accompanying drawings.

22

Amendments to the claims have been filed as follows

Claims

1. Gas sensor with an open optical measuring path
for the optical measurement of at least one gas
5 component, with a light-source unit and a
detector unit, between which the optical
measuring path extends, wherein
- the light-source unit comprises a light
source and optical guide elements for
10 sending out a beam of measuring light to the
detector unit,
 - the detector unit comprises a detector
which, when aligned in the beam path of the
beam of measuring light, registers the
15 intensity of light from the beam of
measuring light, and
 - first and second controlling and evaluating
devices are provided for determining, on the
basis of the measured signal of the
20 detector, a measure of the concentration of
the gas component to be investigated, and
controlling the light source and the
detector,
 - the light-source unit is provided with a
25 transmitter device which is linked to the
first controlling and evaluating device in
the light-source unit, and
 - the detector unit is provided with a
receiver device which is linked to the
30 second controlling and evaluating device in
the detector unit,
and wherein
 - the detector unit is additionally provided
with a transmitter device which is linked to
35 the second controlling and evaluating device
in the detector unit,



- the light-source unit is additionally provided with a receiver device which is linked to the first controlling and evaluating device in the light-source unit, so that a direct bidirectional exchange of data between detector unit and light-source unit is made possible,
 - the optical guide elements in the light-source unit are capable of being adjusted in their alignment by means of an electrical drive,
 - further optical guide elements are provided in the detector unit which are capable of being adjusted in their alignment by means of an electrical drive, and
 - the controlling and evaluating devices are arranged to interact in such a way as to perform an optimal optical adjustment automatically by controlling the alignment of the optical guide elements, utilising the transmission of data between the light-source unit and the detector unit.
2. Gas sensor according to Claim 1, wherein at least one pair of transmitter and receiver devices in the light-source unit and in the detector unit is arranged for wireless transmission of data.
3. Gas sensor according to Claim 1 or 2, wherein with a view to wireless transmission of data a pair of interacting transmitter and receiver devices comprises a light source and a sensor responding to the light of the light source.

4. Gas sensor according to Claim 1 or 2, wherein a pair of interacting transmitter and receiver devices are connected by cable.

5. Gas sensor according to Claim 4, wherein the cable connection comprises an electrically conductive cable or an optical-fibre cable and the transmitter device transmits electrical signals or light signals and the receiver device responds to electrical signals or to light signals.

6. Gas sensor according to Claim 1, wherein the transmitter device in the light-source unit and the receiver device in the detector unit are realised by the first controlling and evaluating device in the light-source unit being arranged in such a way that via a light-source control it modulates the frequency and/or amplitude of the light emitted from the light source in order to transmit data from the light-source unit to the detector unit, and by the second controlling and evaluating device in the detector unit being arranged to demodulate the modulation of the beam of measuring light and thereby to decode the transmitted data.

7. A gas sensor substantially as herein described, with reference to the accompanying drawings.



Application No: GB 0006401.4
 Claims searched: 1-10

25

Examiner: Iwan Thomas
 Date of search: 17 July 2000

Patents Act 1977
Search Report under Section 17

Databases searched:

UK Patent Office collections, including GB, EP, WO & US patent specifications, in:
 UK Cl (Ed.R): G1A ABGX, ABAG, ACDD, ACDG, ADJA, ADJX
 Int Cl (Ed.7): G01N 21/27, 21/31, 21/33, 21/35, 21/59 ('94 on)
 Other: Online: WPI, EPODOC, JAPIO

Documents considered to be relevant:

Category	Identity of document and relevant passage	Relevant to claims
A	GB 2274163A (POLLUTION MONITORING SYSTEMS) See especially last line of abstract	
X	GB 2057121A (HOCHIKI) See abstract, figs. 1 and 2 and page 1 line 75 - 125	1, 2, 6 at least
A	US 5371367A (ENVIROTEST) See abstract, and col. 2 lines 47 - 54	

X	Document indicating lack of novelty or inventive step	A	Document indicating technological background and/or state of the art.
Y	Document indicating lack of inventive step if combined with one or more other documents of same category.	P	Document published on or after the declared priority date but before the filing date of this invention.
&	Member of the same patent family	E	Patent document published on or after, but with priority date earlier than, the filing date of this application.