



(19) **United States**

(12) **Patent Application Publication**

(10) **Pub. No.: US 2003/0064794 A1**

**Mead et al.**

(43) **Pub. Date:**

**Apr. 3, 2003**

(54) **GAMING DEVICE HAVING A MULTIPLE ROUND GAME THAT INCLUDES PLAYER CHOICES AND PROCESSOR CHOICES**

**Publication Classification**

(51) **Int. Cl.<sup>7</sup>** ..... **A63F 13/00**  
(52) **U.S. Cl.** ..... **463/25; 463/20; 463/21; 463/22**

(76) **Inventors:** **Randall D. Mead**, Reno, NV (US);  
**Bayard S. Webb**, Sparks, NV (US);  
**Ryan W. Cuddy**, Reno, NV (US); **John H. Zielinski**, Reno, NV (US)

(57) **ABSTRACT**

The present invention provides a gaming device having a game that may be implemented in a primary or bonus game. In one primary embodiment, the gaming device assigns an allotted number to each choice of a set of choices. The gaming device displays the set of choices for a first round. The gaming device prompts the player to select one of the choices. Upon the player's pick of one of the choices, the gaming device starts an award sequence for the first round. The award sequence generates choices and awards until one of the choices is generated its allotted number of times. If this choice is the same as the player's choice, the game ends, if not, the player advances to a second round.

Correspondence Address:  
**BELL, BOYD & LLOYD LLC**  
**P. O. BOX 1135**  
**CHICAGO, IL 60690-1135 (US)**

(21) **Appl. No.:** **09/966,855**

(22) **Filed:** **Sep. 28, 2001**

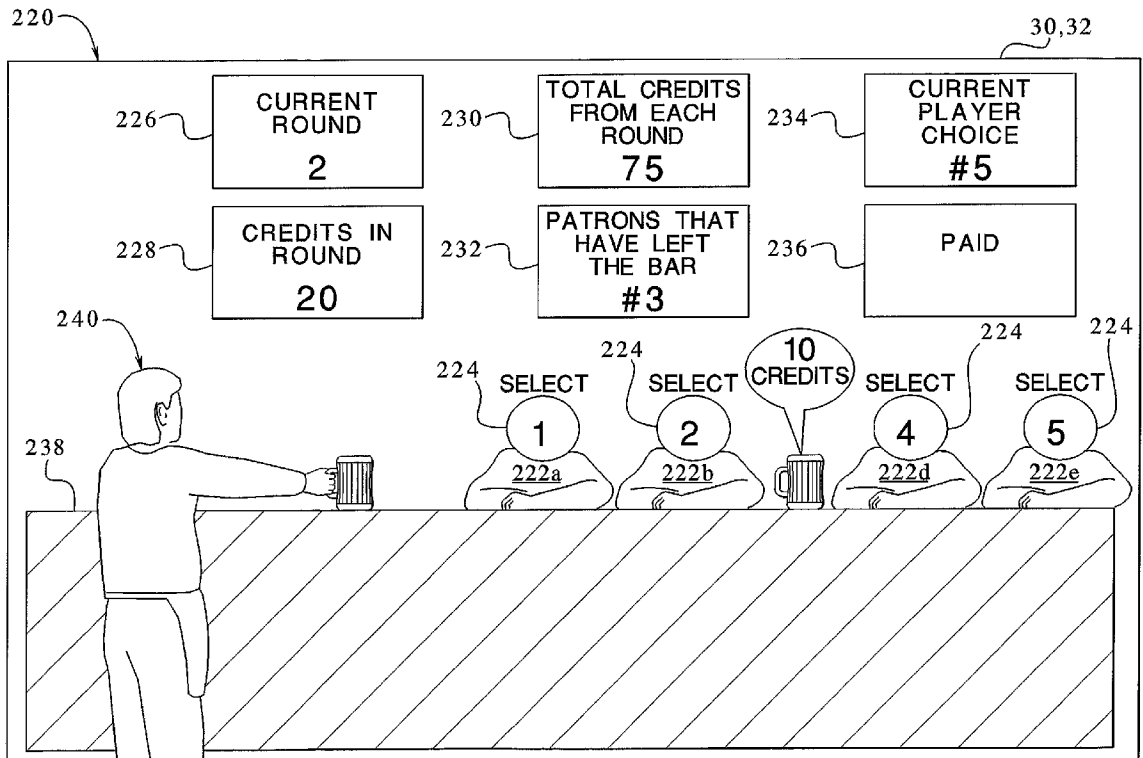

FIG. 1A

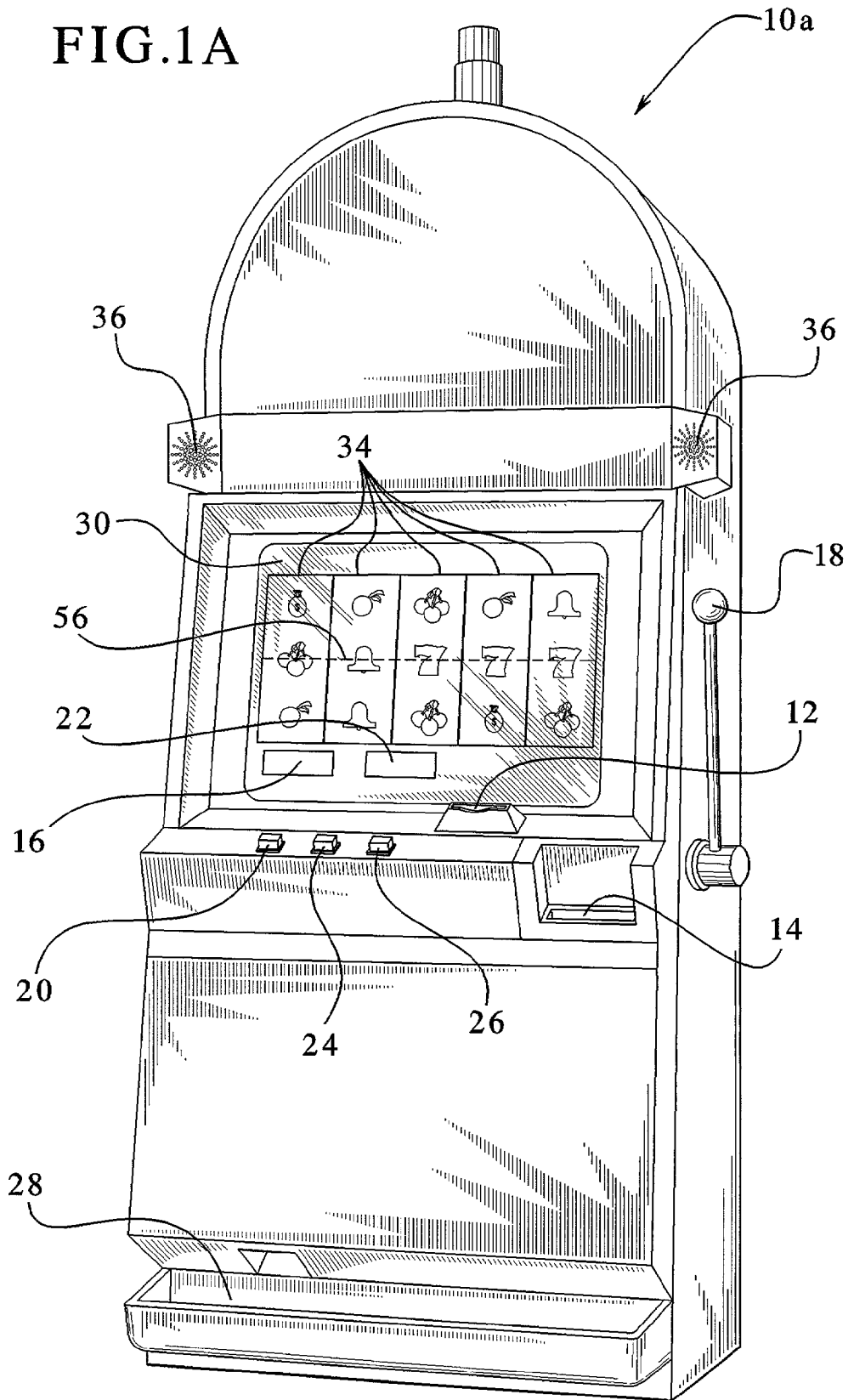

FIG. 1B

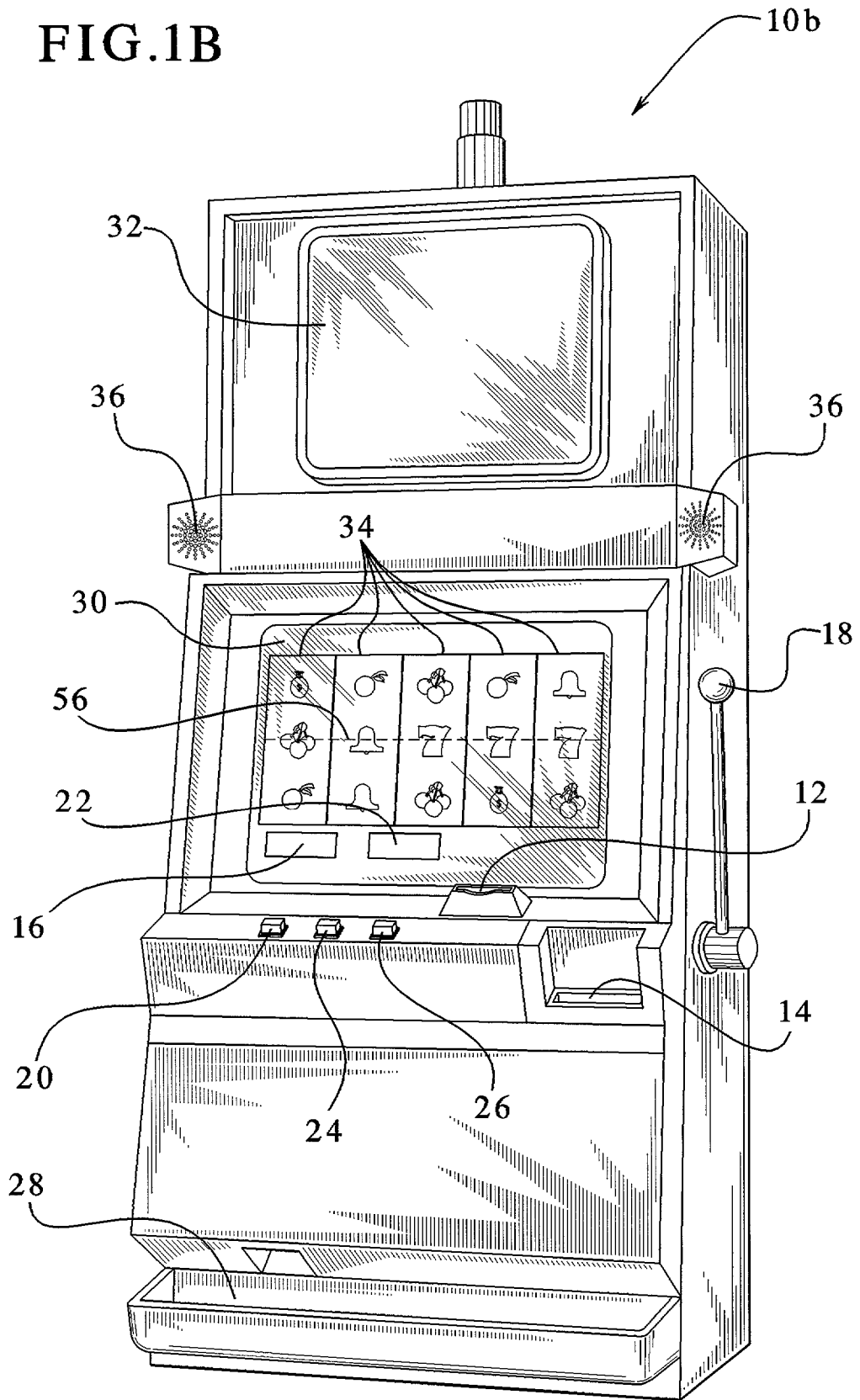

FIG. 2

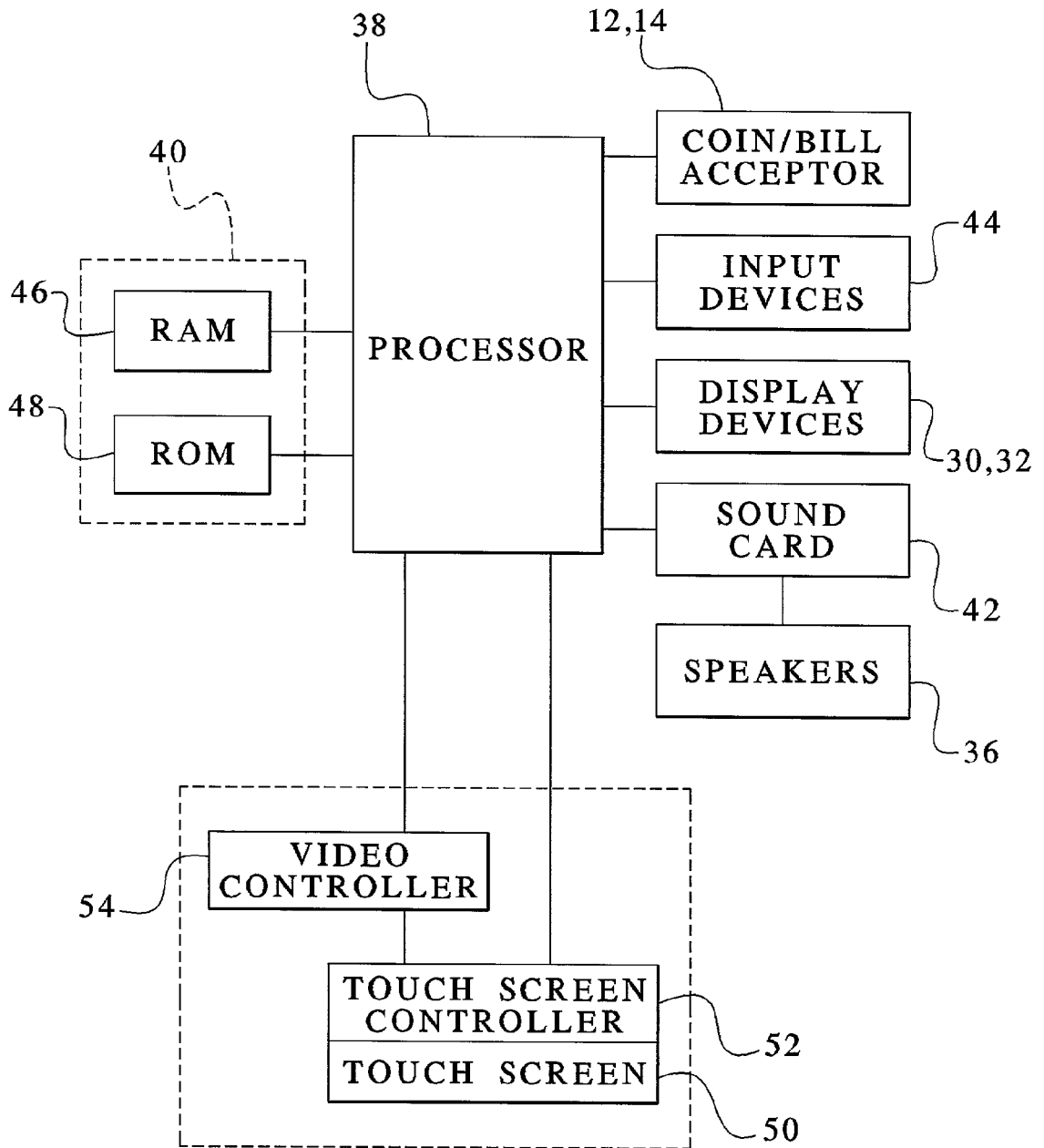

FIG. 3

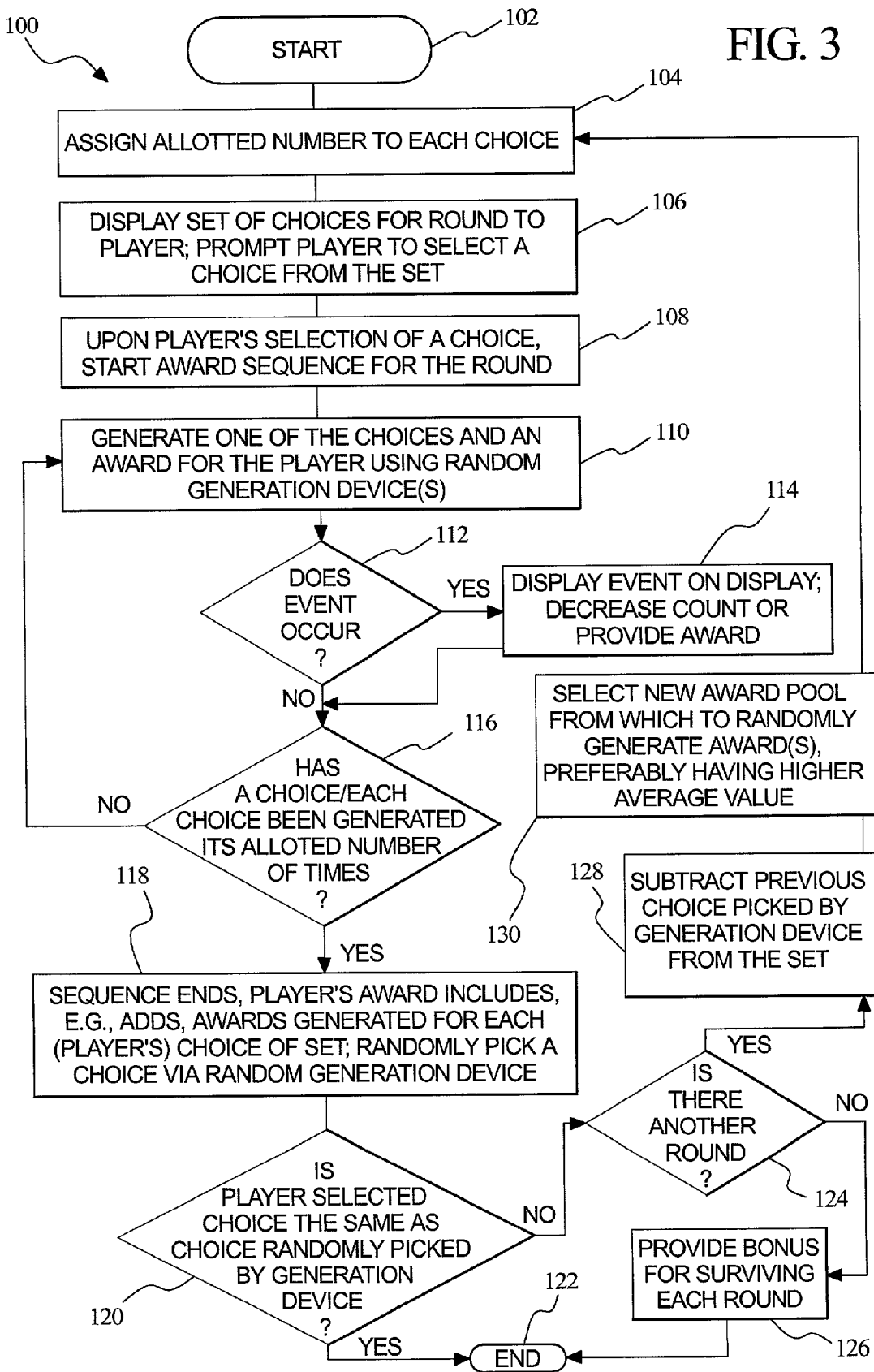

FIG. 4

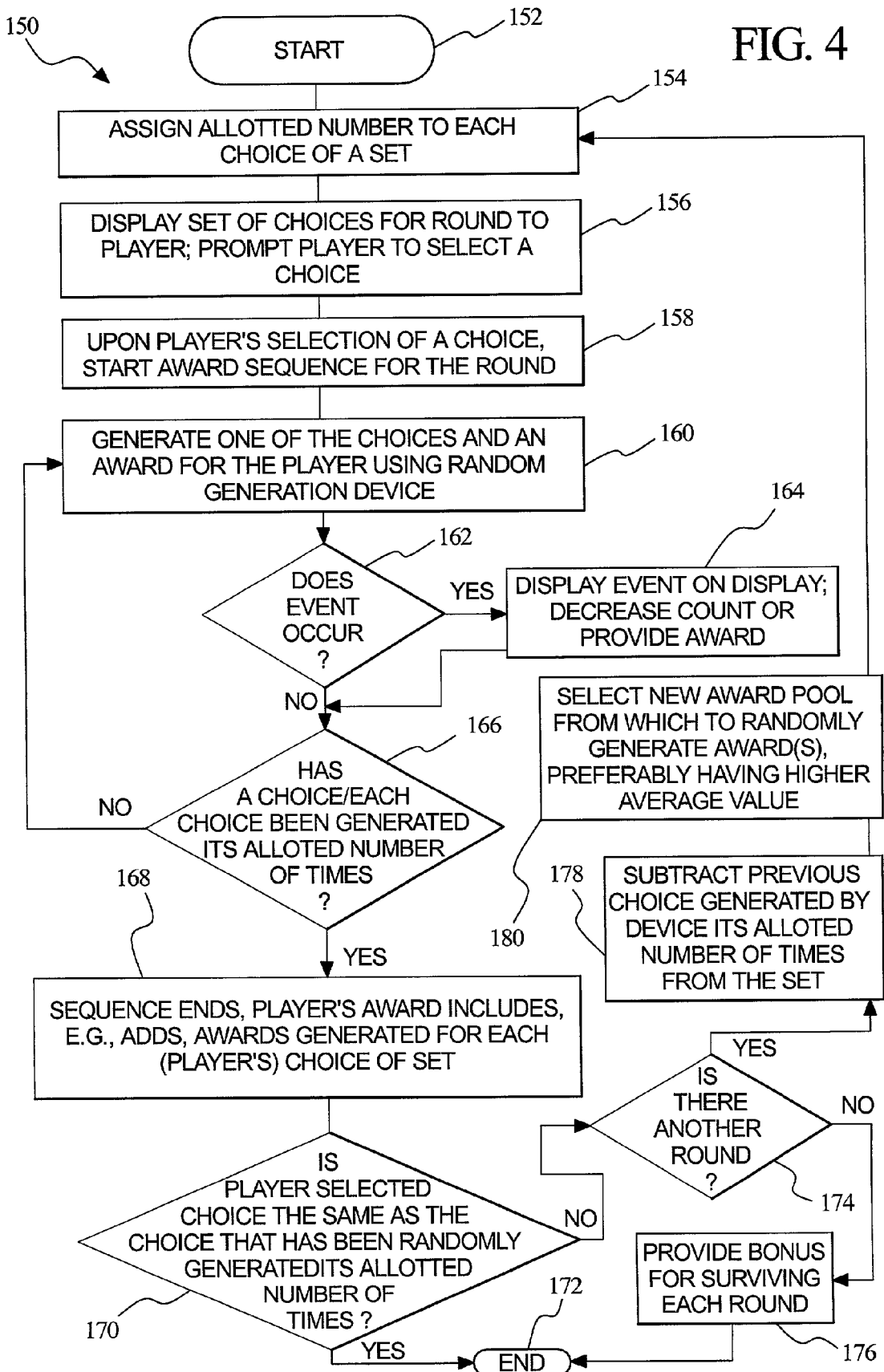

FIG. 5

190

ALLOTTED NUMBER TABLE

|          |               |
|----------|---------------|
| CHOICE 1 | 1, 2, 3, 4, 5 |
| CHOICE 2 | 2, 4, 6       |
| CHOICE 3 | 1, 2, 4       |
| CHOICE 4 | 2, 3, 4, 5, 6 |
| CHOICE 5 | 1, 3, 5, 7    |

192

192

192

192

192

194

194

194

194

194

40

Detailed description: This diagram shows a table titled 'ALLOTTED NUMBER TABLE' enclosed in a cloud-like border labeled '40'. The table has two columns and five rows. The first column lists 'CHOICE 1' through 'CHOICE 5'. The second column lists the numbers for each choice: '1, 2, 3, 4, 5', '2, 4, 6', '1, 2, 4', '2, 3, 4, 5, 6', and '1, 3, 5, 7'. Reference numerals '190' points to the table title, '192' points to each row, and '194' points to each cell in the second column.

FIG. 6

200

AWARD POOL

|        |    |
|--------|----|
| ROUND1 | 5  |
| ROUND2 | 10 |
| ROUND3 | 15 |
| ROUND4 | 20 |
| BONUS  | 50 |

202

40

Detailed description: This diagram shows a table titled 'AWARD POOL' enclosed in a cloud-like border labeled '40'. The table has two columns and five rows. The first column lists 'ROUND1', 'ROUND2', 'ROUND3', 'ROUND4', and 'BONUS'. The second column lists the corresponding award amounts: '5', '10', '15', '20', and '50'. Reference numeral '200' points to the table title, and '202' points to the 'BONUS' row.

FIG. 7

210

| AWARD POOL |          |
|------------|----------|
| ROUND1     | 1 - 10   |
| ROUND2     | 5 - 15   |
| ROUND3     | 10 - 20  |
| ROUND4     | 15 - 25  |
| BONUS      | 50 - 100 |

212 212 212 212

40

FIG. 8

214

| ROUND 1 |       |
|---------|-------|
| 1       | 5 %   |
| 2       | 7.5 % |
| 3       | 10 %  |
| 4       | 15 %  |
| 5       | 20 %  |
| 6       | 15 %  |
| 7       | 10 %  |
| 8       | 7.5 % |
| 9       | 5 %   |
| 10      | 5 %   |

212 216 216 216



FIG. 9

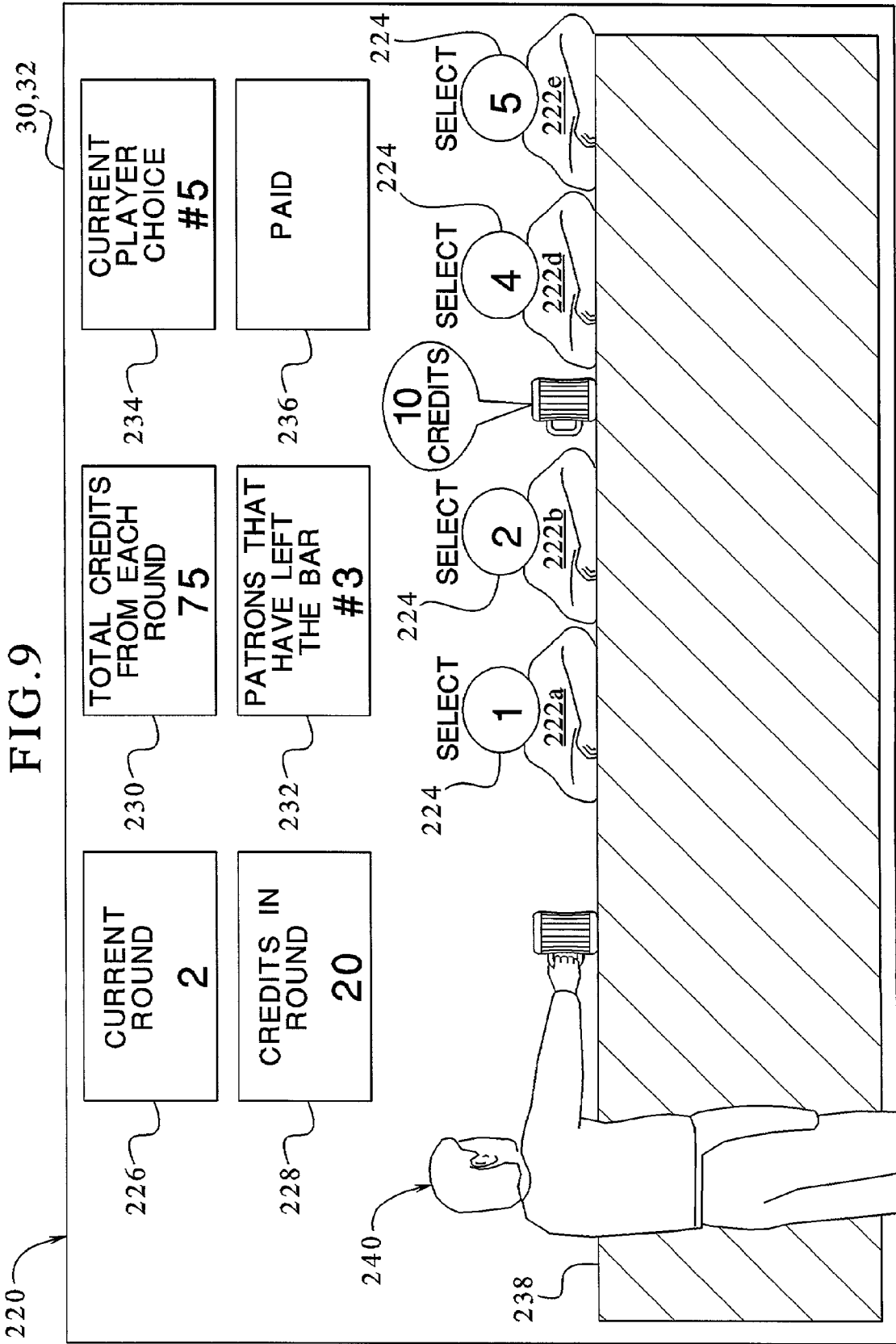

## GAMING DEVICE HAVING A MULTIPLE ROUND GAME THAT INCLUDES PLAYER CHOICES AND PROCESSOR CHOICES

### CROSS REFERENCES TO RELATED APPLICATIONS

[0001] This application is related to the following co-pending commonly owned applications: "Gaming Device Having Bonus Round With A Win, Lose or Draw Outcome," Ser. No. 09/772,763, Attorney Docket No. 0112300-034; and "Gaming Device Having A Multiple Selection And Award Distribution Bonus Scheme," Ser. No. 09/688,635, Attorney Docket No. 0112300-476.

### COPYRIGHT NOTICE

[0002] A portion of the disclosure of this patent document contains or may contain material which is subject to copyright protection. The copyright owner has no objection to the photocopy reproduction by anyone of the patent document or the patent disclosure in exactly the form it appears in the Patent and Trademark Office patent file or records, but otherwise reserves all copyright rights whatsoever.

### DESCRIPTION

[0003] The present invention relates in general to a gaming device, and more particularly to a gaming device that includes a multi-round game wherein the player accumulates awards, and maximizes award accumulation by selecting a different choice from a set of choices than a choice generated by the processor of the gaming device.

### BACKGROUND OF THE INVENTION

[0004] Known gaming devices provide award associates with masked selections. European Patent Application No. EP 0 945 837 A2 filed on Mar. 18, 1999 and assigned on its face to WMS Gaming, Inc. discloses a slot machine game, wherein the gaming device operates in a normal slot machine or basic mode by randomly selecting a basic game outcome from a plurality of basic game outcomes. If the game selects a start bonus outcome, the gaming device shifts from the normal slot machine or basic mode to a bonus mode.

[0005] In the bonus mode, which operates under player control, the player has one or more opportunities to pick masked selections. The masked selections mask awards and end-bonus outcomes. When the player picks a masked selection associated with an award, the game reveals the award and provides the award to the player. When the player picks a masked selection associated with an end-bonus outcome, the bonus mode no longer enables the player to pick masked selections.

[0006] The select-until or do-until selection loop is exciting for the player because the player accrues awards until picking an end-bonus outcome. The do-until selection loop provides the player with the sense that the player controls the player's own destiny. The game of the European Patent Application No. EP 0 945 837 A2 is somewhat limited in that it provides and displays a single masked selection pool from which the player selects. Upon the first pick of an end-bonus outcome, the game ends. There is, therefore, a continuing need for more enjoyable and entertaining do-until types of games for gaming devices.

### SUMMARY OF THE INVENTION

[0007] The present invention provides a gaming device having a game that may be implemented in a primary or bonus game. More specifically, the present invention provides a processor controlled gaming device that includes a multi-round game wherein each round includes a player choice and a game choice. In one primary embodiment, the gaming device includes a plurality of rounds, and begins a first round by assigning an allotted number to each choice in a set of choices. The gaming device displays the set of choices on a display to a player. The gaming device prompts the player to select one of the choices. Upon the player's pick of one of the choices, the gaming device starts an award sequence for the first round.

[0008] In the sequence, the gaming device generates one of the choices and in association with generating the choice, the gaming device also generates an award for the player. The gaming device employs one or more well known random generation devices to generate the choice and the award. Alternatively, the gaming device only generates an award when the player's choice is generated or when one of a number of choices is generated.

[0009] The gaming device repeats the generation of choices and awards until, in one implementation, a choice of the set has been generated its allotted number of times. In another implementation, the gaming device repeats the generation of choices and awards until more than one or all of the choices of the set have been generated their allotted number of times. The gaming device adds or otherwise accumulates each award generated during the sequence.

[0010] When the generation device has generated one or more or all of the choices its allotted number of times, the sequence of the first round ends. The player's award for the first round in a preferred embodiment includes each award generated for each choice of the set.

[0011] The player's award depends in part upon the number assigned to each choice. The higher the numbers, the more times a choice can be generated and the more times an award for the choice may be generated. In a preferred embodiment, different choices of the sets will have different allotted numbers and generate more or less awards.

[0012] In this primary embodiment, after a sequence ends, a random generation device randomly picks a choice from the set. The gaming device then makes a comparison between the player's initial pick of a choice for the round and the choice of the set that the game randomly picked. If the choice that the player has selected is the same as the choice that the game has randomly picked, then no further rounds occur and the game ends.

[0013] If the choice that the player selects is different than the choice that the random generation device picks, the gaming device determines whether another round exists. That is, the gaming device stores a number of rounds for each game. If the player survives each round stored in memory without selecting the same choice that the gaming device randomly picks, the gaming device provides an extra bonus award and then ends the game.

[0014] If another round exists, the gaming device removes the choice generated by the gaming device in the previous sequence from the set. The gaming device also selects from

memory another award pool from which the random generation device generates awards in the next sequence. In a preferred embodiment, the game chooses a new award pool that has higher average value awards than the previous award pool. The game then repeats the process herein described by assigning an allotted number to each choice for the next round and the next sequence.

[0015] In another primary embodiment, the gaming device proceeds substantially as described above. That is, the gaming device displays a set of choices for a first round to the player and prompts the player to select a choice. Upon the player's pick of a choice, the gaming device begins the sequence for the first round. Once again, a random generation device generates choices from a set of choices displayed during the sequence. A random generation device also generates awards and preferably generates the awards one to one with the generation of the choices.

[0016] In this primary embodiment however, the sequence ends when the first choice of the set is generated its allotted number of times. In the previous primary embodiment, a plurality of choices of the first set may have to be generated their allotted number of times. Also different in this sequence, the gaming device does not randomly pick a choice from the set at the end of the sequence. Rather, the choice that has been generated its allotted number of times is the choice that the gaming device compares to the choice selected by the player.

[0017] In this primary embodiment, the player's award for each round preferably includes each award generated in the set. In this primary embodiment, the award for each round may be less than the award per round in the previous primary embodiment when, in the previous embodiment, a plurality of choices are generated their allotted number of times.

[0018] A number of different data tables may be employed for randomly assigning an allotted number to each choice and for generating awards within any given round. Certain additional events contemplated by the present invention include a randomly occurring event that lessens the number of times that one or more choices have been generated. For example, if a particular choice has an allotted number of five and has been generated four times within the round, it can only be generated one more time. The random event however lessens the number of times, e.g., from four to two or four to zero, so that now the choice can be generated three more times. Another randomly occurring event includes an event that multiplies one or more of the awards generated during the round.

[0019] It is therefore an advantage of the present invention to provide a gaming device that has a do-until routine employing multiple rounds.

[0020] It is another advantage of the present invention to provide a gaming device that has multiple rounds, wherein each round pits a player's choice against a choice made by the gaming device.

[0021] It is a further advantage of the present invention to provide a gaming device that has multiple rounds, wherein each round has a plurality of choices each having an allotted number, and wherein the round ends when a first choice is generated by the gaming device its allotted number of times.

[0022] It is still another advantage of the present invention to provide a gaming device that has multiple rounds,

wherein each round has a plurality of choices each having an allotted number, and wherein the round ends when each choice is generated by the gaming device its allotted number of times.

[0023] It is yet another advantage of the present invention to provide a gaming device that has multiple rounds, wherein each round has a plurality of choices each having an allotted number, and wherein the round provides an award to the player based on a number of times that the gaming device generates choices within the round.

[0024] Other objects, features and advantages of the invention will be apparent from the following detailed disclosure, taken in conjunction with the accompanying sheets of drawings, wherein like numerals refer to like parts, elements, components, steps and processes.

#### BRIEF DESCRIPTION OF THE DRAWINGS

[0025] FIG. 1A is a front perspective view of one embodiment of the gaming device of the present invention.

[0026] FIG. 1B is a front perspective view of another embodiment of the gaming device of the present invention.

[0027] FIG. 2 is a schematic block diagram of the electronic configuration of one embodiment of the gaming device of the present invention.

[0028] FIG. 3 is a logic flow diagram for one embodiment of a game program of the present invention.

[0029] FIG. 4 is a logic flow diagram for another embodiment of a game program of the present invention.

[0030] FIG. 5 schematically illustrates an area of memory having one embodiment of a data table for assigning an allotted number to each choice of the present invention.

[0031] FIG. 6 schematically illustrates an area of memory having one embodiment of a data table for generating awards of the present invention.

[0032] FIG. 7 schematically illustrates an area of memory having another embodiment of a data table for generating awards of the present invention.

[0033] FIG. 8 schematically illustrates an area of memory having a further embodiment of a data table for generating awards of the present invention.

[0034] FIG. 9 is an elevation view of one display having a theme that depicts one of the logic sequences of the present invention.

#### DETAILED DESCRIPTION OF THE INVENTION

##### Gaming Device and Electronics

[0035] Referring now to the drawings, and in particular to FIGS. 1A and 1B, gaming device 10a and gaming device 10b illustrate two possible cabinet styles and display arrangements and are collectively referred to herein as gaming device 10. The present invention includes the game (described below) being a stand alone game or a bonus or secondary game that coordinates with a base game. When the game of the present invention is a bonus game, gaming device 10 in one base game is a slot machine having the controls, displays and features of a conventional slot

machine, wherein the player operates the gaming device while standing or sitting. Gaming device **10** also includes being a pub-style or table-top game (not shown), which a player operates while sitting.

[0036] The base games of the gaming device **10** include slot, poker, blackjack or keno, among others. The gaming device **10** also embodies any bonus triggering events, bonus games as well as any progressive game coordinating with these base games. The symbols and indicia used for any of the base, bonus and progressive games include mechanical, electrical or video symbols and indicia.

[0037] In a stand alone or a bonus embodiment, the gaming device **10** includes monetary input devices. **FIGS. 1A and 1B** illustrate a coin slot **12** for coins or tokens and/or a payment acceptor **14** for cash money. The payment acceptor **14** also includes other devices for accepting payment, such as readers or validators for credit cards, debit cards or smart cards, tickets, notes, etc. When a player inserts money in gaming device **10**, a number of credits corresponding to the amount deposited is shown in a credit display **16**. After depositing the appropriate amount of money, a player can begin the game by pulling arm **18** or pushing play button **20**. Play button **20** can be any play activator used by the player which starts any game or sequence of events in the gaming device.

[0038] As shown in **FIGS. 1A and 1B**, gaming device **10** also includes a bet display **22** and a bet one button **24**. The player places a bet by pushing the bet one button **24**. The player can increase the bet by one credit each time the player pushes the bet one button **24**. When the player pushes the bet one button **24**, the number of credits shown in the credit display **16** decreases by one, and the number of credits shown in the bet display **22** increases by one. At any time during the game, a player may "cash out" by pushing a cash out button **26** to receive coins or tokens in the coin payout tray **28** or other forms of payment, such as an amount printed on a ticket or credited to a credit card, debit card or smart card. Well known ticket printing and card reading machines (not illustrated) are commercially available.

[0039] Gaming device **10** also includes one or more displays. The embodiment shown in **FIG. 1A** includes a central display **30**, and the alternative embodiment shown in **FIG. 1B** includes a central display **30** as well as an upper display **32**. The displays display any visual representation or exhibition, including but not limited to movement of physical objects such as mechanical reels and wheels, dynamic lighting and video images. The display includes any viewing surface such as glass, a video monitor or screen, a liquid crystal display or any other static or dynamic display mechanism. In a video poker, blackjack or other card gaming machine embodiment, the display includes displaying one or more cards. In a keno embodiment, the display includes displaying numbers.

[0040] The slot machine base game of gaming device **10** preferably displays a plurality of reels **34**, preferably three to five reels **34**, in mechanical or video form on one or more of the displays. Each reel **34** displays a plurality of indicia such as bells, hearts, fruits, numbers, letters, bars or other images which preferably correspond to a theme associated with the gaming device **10**. If the reels **34** are in video form, the display displaying the video reels **34** is preferably a video monitor. Each base game, especially in the slot machine base

game of the gaming device **10**, includes speakers **36** for making sounds or playing music.

[0041] Referring now to **FIG. 2**, a general electronic configuration of the gaming device **10** for the stand alone and bonus embodiments described above preferably includes: a processor **38**; a memory device **40** for storing program code or other data; a central display **30**; an upper display **32**; a sound card **42**; a plurality of speakers **36**; and one or more input devices **44**. The processor **38** is preferably a microprocessor or microcontroller-based platform which is capable of displaying images, symbols and other indicia such as images of people, characters, places, things and faces of cards. The memory device **40** includes random access memory (RAM) **46** for storing event data or other data generated or used during a particular game. The memory device **40** also includes read only memory (ROM) **48** for storing program code, which controls the gaming device **10** so that it plays a particular game in accordance with applicable game rules and pay tables.

[0042] As illustrated in **FIG. 2**, the player preferably uses the input devices **44** to input signals into gaming device **10**. In the slot machine base game, the input devices **44** include the pull arm **18**, play button **20**, the bet one button **24** and the cash out button **26**. A touch screen **50** and touch screen controller **52** are connected to a video controller **54** and processor **38**. The terms "computer" or "controller" are used herein to refer collectively to the processor **38**, the memory device **40**, the sound card **42**, the touch screen controller and the video controller **54**.

[0043] In certain instances, it is preferable to use a touch screen **50** and an associated touch screen controller **52** instead of a conventional video monitor display. The touch screen enables a player to input decisions into the gaming device **10** by sending a discrete signal based on the area of the touch screen **50** that the player touches or presses. As further illustrated in **FIG. 2**, the processor **38** connects to the coin slot **12** or payment acceptor **14**, whereby the processor **38** requires a player to deposit a certain amount of money in to start the game.

[0044] It should be appreciated that although a processor **38** and memory device **40** are preferable implementations of the present invention, the present invention also includes being implemented via one or more application-specific integrated circuits (ASIC's), one or more hard-wired devices, or one or more mechanical devices (collectively referred to herein as a "processor"). Furthermore, although the processor **38** and memory device **40** preferably reside in each gaming device **10** unit, the present invention includes providing some or all of their functions at a central location such as a network server for communication to a playing station such as over a local area network (LAN), wide area network (WAN), Internet connection, microwave link, and the like.

[0045] With reference to the slot machine base game of **FIGS. 1A and 1B**, to operate the gaming device **10**, the player inserts the appropriate amount of tokens or money in the coin slot **12** or the payment acceptor **14** and then pulls the arm **18** or pushes the play button **20**. The reels **34** then begin to spin. Eventually, the reels **34** come to a stop. As long as the player has credits remaining, the player can spin the reels **34** again. Depending upon where the reels **34** stop, the player may or may not win additional credits.

[0046] In addition to winning base game credits, the gaming device **10**, including any of the base games disclosed above, also includes bonus games that give players the opportunity to win credits. The gaming device **10** preferably employs a video-based display **30** or **32** for the bonus games. The bonus games include a program that automatically begins when the player achieves a qualifying condition in the base game.

[0047] In the slot machine embodiment, the qualifying condition includes a particular symbol or symbol combination generated on a display. As illustrated in the five reel slot game shown in **FIGS. 1A and 1B**, the qualifying condition includes the number seven appearing on, e.g., three adjacent reels **34** along a payline **56**. It should be appreciated that the present invention includes one or more paylines, such as payline **56**, wherein the paylines can be horizontal, diagonal or any combination thereof. An alternative scatter pay qualifying condition includes the number seven appearing on, e.g., three adjacent reels **34** but not necessarily along a payline **56**, appearing on any different set of reels **34** three times or appearing anywhere on the display the necessary number of times.

[0048] Referring now to **FIG. 3**, the occurrence of the qualifying condition or triggering event, the gaming device **10** begins a game sequence **100** embodying one primary embodiment of the present invention, as indicated by oval **102**. The gaming device **10** assigns an allotted number to each choice of a set, as indicated by block **104**. The gaming device **10** displays the set of choices on a display **30** or **32**, as indicated by block **106**. The gaming device **10** does not in a preferred embodiment display the allotted number associated with each choice of the set. However, in an alternative embodiment the gaming device **10** displays the allotted numbers. The gaming device **10** prompts the player to select a choice from the set, as also indicated by block **106**. The gaming device includes a selector such as a touch screen or other suitable device including electro-mechanical or mechanical buttons or indicators for enabling the player to pick a choice. The gaming device **10** may employ an audio, visual, or audiovisual prompt that is in a preferred embodiment in accordance with a theme of the invention.

[0049] Upon a player's pick of a choice from the set displayed on the display **30** or **32**, gaming device **10** begins an award sequence for the first round, as indicated by block **108**. A sequence of the present invention includes the generation of choices using a random generation device and a generation of awards using the same or a different random generation device. The random generation device in one embodiment includes the processor randomly determining choices and awards. The player may be allowed to select a choice at any time before the award sequence begins.

[0050] In the award sequence, the gaming device **10** generates one of the choices and an award for the player using one or more random generation devices as indicated by block **110**. Data tables for generating the awards are described below. During or after the generation of a choice and an associated award, the gaming device **10** randomly determines whether to provide a modifier event such as a number or choice changing event, as indicated by diamond **112**. If the gaming device **10** generates a modifier event such as a number or choice changing event, the display **30** or **32** displays the event, as indicated by block **114**. The events

include decreasing a number of times that one or more choices has been generated, so as to allow such choices to be generated more times before those choices reach their allotted number. For example, the event can reset each choice to zero so that the sequence, in effect, starts over. The player, however, keeps any awards provided before the event occurs.

[0051] The modifier event may also include providing a multiplier for the player. For example, in one embodiment, the event includes randomly generating one of the choices, and if the choice generated is the choice that the player has selected, gaming device **10** provides a multiplier. The multiplier may be adapted to multiply a previously generated award, each award that has been generated within the current award sequence, or the player's total accumulated award for each round.

[0052] Whether or not an event occurs, the gaming device **10** in one implementation determines whether a choice of the set on the display **30** or **32** has been generated its allotted number of times as indicated by diamond **116**. If a choice has not been generated its allotted number of times, the game program returns to block **110**, wherein a random generation device of the gaming device **10** generates one of the choices and an award in association with one of the choices. It should be appreciated, that the game program continues to loop and generate choices and awards until one of the choices has been generated its allotted number of times. During each loop, one of the modifier events described above may occur.

[0053] In an alternative embodiment, the gaming device **10** determines if a plurality of or all of the choices in the set have been generated their allotted number of times. Here, the game program continues to loop and generate choices and awards until a plurality or all of the choices are generated their respective allotted number of times.

[0054] As illustrated, in a preferred embodiment, the gaming device generates an award with each generation of a choice from the set. In alternative embodiments, the gaming device may be adapted to generate awards on a different basis. For example, the gaming device may be programmed to generate an award every other generation of a choice. Or, the game may only generate an award when the gaming device randomly generates the player's choice. Other implementations for generating awards in association with generating choices may be employed in accordance with the present invention.

[0055] When one, a plurality of or all of the choices have been generated their allotted number of times in a round, the award sequence ends as indicated by block **118**. The player's award for the round and the sequence includes each award generated in association with the generation of the choices. In a preferred embodiment, gaming device sums each award generated during the round. Alternatively, however, gaming device **10** may multiply the awards or provide some combination of multiplication or summation. In a preferred embodiment, the awards of the present invention are gaming device credits. The awards may alternatively be multipliers that multiply a number of gaming device credits. That is, the multipliers may multiply a player's wager or a component of the player's wager such as the bet per payline or the number of paylines played. The multipliers may also multiply a player's win along one or more paylines. The awards may

further alternatively be other items of value such as a number of picks from a prize pool.

[0056] In one embodiment, the gaming device employs a random generation device to randomly pick one of the choices from the set, as also indicated by block 118. This random pick of a choice from the set is not for the purpose of generating an award for the player; rather, gaming device 10 compares the random pick to the player's selected choice (block 108), as indicated by diamond 120. That is, gaming device uses the comparison of choices to determine whether the player advances to a next round.

[0057] In this embodiment, the gaming device's pick of a choice in determining whether the player advances to the next round, as determined in connection with block 118, may be done at different points in the game program. For example, gaming device 10 may be adapted to pre-pick each choice for each round before beginning any of the rounds. Gaming device 10 can pick the choice at any point during the sequence of a round. Or, gaming device 10 may pick the choice after the sequence has ended, as illustrated by block 118.

[0058] If the player's selected choice and the game's randomly picked choice are the same, as determined in connection with diamond 120, the program of gaming device 10 ends as indicated by oval 122. At this point, gaming device 10 transfers or provides any accumulated award to the player.

[0059] If the choice selected by the player is not the same as the choice picked from the set by the generation device, gaming device 10 determines whether another round exists, as indicated by diamond 124. As illustrated in the data tables below, gaming device 10 in a preferred embodiment pre-determines the number of rounds that the player may play. When the player plays each round, that is, survives each round without selecting the same choice that gaming device 10 randomly picks, gaming device 10 provides a bonus award to the player for surviving each round, as indicated by block 126. The bonus award in a preferred embodiment is relatively large compared to the awards provided in association with the choices. The bonus award may be a number of credits, a multiplier or may allow the player to play one or more extra award sequences. After providing the bonus award to the player, the game program of gaming device 10 ends, as indicated by oval 122.

[0060] If the player survives the round, as determined in connection with diamond 120, and another round exists, as determined in connection with diamond 124, the gaming device 10 performs a number of updates before the player begins the next round. One update that gaming device 10 makes in a preferred embodiment is the subtraction of the choice picked by the generation device in the previous round from the set of choices displayed in the next round, as indicated by block 128. That is, the set of choices displayed in the next round on the display 30 or 32 has, in a preferred embodiment, one less choice than the set displayed in the previous round. In this way, succeeding rounds become harder for the player to survive. It is more likely in successive rounds that the player selects the same choice that the gaming device randomly picks because there are less choices in the set.

[0061] Another update that gaming device 10 makes in a preferred embodiment is the selection of a new award pool

as indicated by block 130. In a preferred embodiment, the next award pool has a higher average value of awards than the previous award pool. As the rounds become harder to advance through or survive, the rounds also preferably provide higher average awards. After gaming device 10 selects a new award pool, as indicated by block 130, gaming device 10 assigns new allotted numbers to the remaining choices of this set for the next round, as indicated by block 104.

[0062] It should be appreciated that in the game program embodying the method 100 of FIG. 3, gaming device 10 cycles through the above-described procedure until: (i) the player selects the same choice that gaming device 10 picks; or (ii) the player successfully plays each round stored in memory. Gaming device 10 accumulates the awards achieved during each round until one of the game ending events occurs, whereby gaming device 10 provides or down-loads this accumulated award to the player.

[0063] Referring now to FIG. 4, another primary embodiment stored in the memory device 40 embodies the method 150. The method 150 is similar to the method 100 described in connection with FIG. 3. Upon the player's input of an appropriate amount of money, gaming device 10 begins the program embodying method 150, as indicated by oval 152. Gaming device 10 assigns an allotted number to each choice of a set as indicated by block 154. Gaming device 10 displays the set of choices on a display 30 or 32 for a round to the player, as indicated by block 156. Gaming device 10 provides an audio, visual, or audiovisual prompt to the player to select a choice from the set, as also indicated by block 156. Upon the player's selection of a choice, gaming device 10 begins an award sequence for the round, as indicated by block 158.

[0064] In the sequence, gaming device 10 generates one of the choices from the set and preferably an award in association with the generated choice, as indicated by block 160. Gaming device 10 employs one or more random generation devices to generate the choice and the award. As in the method 100, gaming device 10 may alternatively generate an award every other generation of a choice, only when the player's choice is generated or upon some other basis as desired by the game implementor.

[0065] Gaming device 10 randomly determines whether a modifier event occurs as indicated by diamond 162. If a modifier event occurs, gaming device 10 displays the event on a display 30 or 32. As before, the event may include decreasing the tally or count for one or more or all of the choices, so that the one or more choices may be randomly generated more than their initial allotted number of times. In one implementation, the modifier event completely resets the round. In this way, gaming device 10 may generate more awards for the player before the sequence and the round ends. Alternatively, the event may include providing a multiplier that multiplies an award provided in the sequence or the total award for each sequence played.

[0066] Whether or not an event occurs, gaming device 10 after generating a choice and an award determines whether a choice has been generated its allotted number of times, as indicated by diamond 166. The method 150 is different from the method 100 because in the method 150, the first choice that is chosen its allotted number of times ends the award sequence. In the method 100, a plurality of choices or all of

the choices may have to be randomly generated their allotted number of times. It should be appreciated in such a case, the method **150** likely ends sooner than in the method **100**. In such a case, the player's number of accumulated awards for any given award sequence of a round in the method **150** is likely smaller than the number of awards in the method **100**.

[**0067**] When the first choice has been randomly generated its allotted number of times, as determined in connection with diamond **166**, the sequence ends and the player's award includes, e.g., sums the awards generated in association with each of the choices of the set. That is, even though the game ends when a single choice is selected its allotted number of times, the player accumulates awards associated with the generation of each of the choices before the round ends. Alternatively, for both methods **100** and **150**, gaming device **10** may only accumulate awards generated in association with the choice that the player selects instead of all of the choices. In the method **150**, another alternative embodiment includes providing only the awards generated in association with the choice, that is, the first to be generated its allotted number of times.

[**0068**] Another distinction between the method **150** and the method **100** is illustrated in connection with diamond **170**. Here, instead of randomly picking one of the choices from the set, gaming device **10** employs the choice that has been generated its allotted number of times to compare against the choice selected by the player. The choice that the game uses to compare with the player's selected choice is still randomly generated in the method **150**, however, this generation may be the combination of a plurality of random generations. For instance, if the game's choice has an associated allotted number of three, the game's choice is a combination of three random generations of that choice.

[**0069**] If the player's selected choice is the same as the game's generated choice, the game program employing the method **150** ends, as indicated by oval **172**, and gaming device **10** transfers or provides any accumulated award to the player. If the player's selected choice is not the same as the game's generated choice, gaming device **10** determines whether another round exists, as indicated by diamond **174**. If another round does not exist, gaming device **10** in a preferred embodiment provides a bonus award to the player for surviving each round stored in memory, as indicated by block **176**.

[**0070**] If another round does exist, as determined in connection with diamond **174**, gaming device **10** performs a number of updates before beginning the next round. Gaming device **10** in a preferred embodiment subtracts the previous choice generated by the random generation device of gaming device **10** from the next displayed set, as indicated by block **178**. That is, whichever choice is the first to be generated in a given award sequence is the choice that will not appear in the set of choices for the next round. Gaming device **10** also preferably updates and increases the award pool for the next round, which preferably has higher average awards, as indicated by block **180**.

[**0071**] The game program employing the method **150** cycles through the above-described process until: (i) gaming device **10** generates a choice its allotted number of times, which is also the same choice as the one the player selects; or (ii) the player survives each round. Gaming device **10** provides and downloads an award to the player equal to an

accumulation of the awards generated in each award sequence before either of the game ending events occurs. The player may also receive a bonus award as indicated in connection with block **176**.

[**0072**] Referring now to **FIG. 5**, an area of the memory device **40** includes data, such as in the form illustrated by data table **190**, for allotting numbers to the choices. Data table **190** illustrates that gaming device **10** provides, in one embodiment, five choices on the display **30** or **32**. Data table **190** illustrates the choices at the beginning of the game, whereby in successive rounds only four choices, three choices, two choices, etc. will be displayed on the display **30** or **32** as described above.

[**0073**] Each choice **192** has an associated number range **194**. The number range **194** includes the possible numbers that may be associated or assigned to the choice. For example, gaming device **10** can assign any number one through five to Choice **1**, assign only the numbers one, two and four to Choice **3** or assign the numbers one, three, five and seven to Choice **5**. The number ranges **194** are adapted in accordance with the game mathematics. It should be appreciated that in either method **100** or **150**, the player desires the highest or top allotted number to be assigned to each choice. That is, the player desires that the game has to generate Choice **1** five times, Choice **2** six times, Choice **3** four times, Choice **4** six times, and Choice **5** seven times in the method **100** or has to generate any one of these in the method **150**.

[**0074**] The table **190** illustrates that each choice **192** has a different number range **194**. In an alternative embodiment, a plurality of the choices **192** could have the same number range **194**. Still further, each choice **192** may have the same number range **194**. For example, each choice **192** in one implementation has the number range of 1, 2, 3, 4 and 5 currently illustrated as associated with Choice **1**.

[**0075**] In another embodiment, one or more or all of the choices **192** have different number ranges in different rounds. For instance, in round **1**, Choice can have the 2, 4 and 6 number range **194** as illustrated, and in round **2** have a 1, 3 and 5 number range **194**, etc. In a preferred embodiment, the average value of the numbers in the ranges **194** decreases as the rounds advance.

[**0076**] Referring now to **FIG. 6**, an area of the memory device **40** stores award information in an award pool such as award pool **200**. In this embodiment, gaming device **10** provides the same award in any given award sequence of any given round. The award pool **200** is illustrated to work in conjunction with the allotted number table **190** of **FIG. 5**. That is, since the allotted number table **190** has five choices, one of which is the player's choice, the maximum number of rounds that may be played is four as indicated by the award pool **200**. In round one, gaming device **10** provides an award of five each time a random generation device generates one of the choices from the set of five choices illustrated in the table **190**. If the player advances to the second round, the gaming device **10** provides an award of ten for each random generation of a choice and so on.

[**0077**] If the player advances through each round of the award pool **200** of **FIG. 6**, gaming device **10** provides a bonus award **202** of fifty. Although not illustrated, an award pool similar to award pool **200** may be adapted to include a

multiplier for one or more rounds when an event occurs that provides a multiplier to the player. The multipliers may increase on average in advancing rounds or be selected from a range of multipliers.

[0078] Referring now to FIG. 7, an alternative award pool 210 is stored in the memory device 40. The award pool 210 includes four rounds as before, however, award pool 210 includes award ranges 212 as opposed to the single award used in the award pool 200. In the award pool 210, the award ranges 212 increase in subsequent rounds. Gaming device 10 randomly generates an award from the award ranges 212. In the award pool 210, each award of an award range 212 is equally weighted with the other awards of the same award range. Alternatively, as discussed below, the award ranges 212 may employ a non-equal weighting distribution.

[0079] The number ranges 194 of the allotted number table 190 and the award ranges 212 of the award pool 210 both, in a preferred embodiment; provide an associated number of at least one and an associated award of at least one credit. The awards of the award pools 200 and 210 are designed and selected according to the game mathematics.

[0080] Referring now to FIG. 8, an alternative portion 214 of an award pool (only showing round one for ease of illustration) is stored in the memory device 40. This alternative portion 214 of round one illustrates that the awards for each round may be weighted. The portion 214 illustrates the round one award range 212 from the award pool 210. In the portion 214, each award one through ten of the range 212 has an associated likelihood or percentage 216. The percentages create a probability distribution for the awards of the award range 212. The game implementor distributes the percentages according to game mathematics. In the illustrated embodiment, the portion 214 provides that the five award has the highest probability 216 of twenty percent. The probabilities 216 taper off as the awards decrease towards one and increase towards ten.

[0081] Referring now to FIG. 9, either of the methods 100 or 150 may be displayed in a plurality of ways. Each of the displays includes a set of choices, one of which the player selects. Each display also includes a method by which gaming device 10 illustrates on the display 30 or 32 the generation of a choice from a set on the display 30 or 32. The gaming device 10 preferably includes a display in accordance with a theme of the gaming device 10. The screen 220 of FIG. 9 corresponds to a saloon or tavern setting, wherein a bartender 238 serves drinks (and points) to patrons 222.

[0082] In FIG. 9 the screen 220 of one of the displays 30 or 32 illustrates one possible display embodiment. The screen 220 displays a plurality of choices 222a, 222b, 222d and 222e to the player. In accordance with the allotted number table 190 of FIG. 5, the gaming device 10 provides five choices.

[0083] In the screen 220, however, only the one, two, four and five choices are displayed. As illustrated further below, choice three has previously been generated by gaming device 10 and is therefore no longer displayed. The display 30 or 32, as described above in connection with FIG. 2, includes a touch screen 50 in association with a touch screen controller 48. The touch screen 50 enables the player to select an area 224 associated with each choice 222a through 222e. As illustrated by a current round meter 226 and a

current player choice meter 234, in the second round, the player has selected the choice five. The player selected choice five by pressing the area 224 associated with the five choice 222e.

[0084] The screen 220 updates the credits accumulated in round two in the meter 228. The screen 220 updates the total credits for each round that the player has played in the meter 230. It should be appreciated that the player accumulated fifty-five credits in round one and has now added twenty credits in the current round two.

[0085] It should also be appreciated from the meter 232, which shows patrons or choices that have been eliminated, Choice 3 was the first choice that gaming device 10 picked, as provided in connection with the method 100, or was the first choice generated its allotted number of times as provided in connection with the method 150. That is, Choice 3 is the choice that gaming device 10 used to compare with the player's selected choice in round one. Obviously, the player selected a different choice because the player is now currently playing round two as indicated by the round meter 226.

[0086] When the player successfully plays each round or selects the same choice that the gaming device generates, gaming device 10 transfers or provides the total awards accumulated in the meter 230 into a paid display 236. In a preferred embodiment the display 30 or 32 counts the number backward in the total credit meter 230 as the paid display accumulates to the number originally appearing in the total credit meter 230. This is commonly referred to as a credit roll-up.

[0087] The screen 220 illustrates one possible theme having a number of choices 222a to 222e which are patrons at a bar 238. A bartender 240 serves drinks to the choices 222a to 222e. The screen illustrates that the bartender 240 has served a drink to Choice 4222d. That is, a random generation device generated Choice 4 and the same or a different random generation device generated an award of ten credits using one of the award pools 200, 210 or 214 illustrated above.

[0088] The display 220 illustrates Choice 4 receiving the drink and the provision of ten credits. In an embodiment where the player receives awards associated with every choice generation, the meter 228 increments by ten credits. However, in an embodiment wherein the player only receives awards generated when the player's selection has been generated, the meter 228 would not increment by the ten credits. As illustrated by the meter 234, the player's current choice is Choice 5.

[0089] In accordance with the theme of the gaming device, in a subsequent round the bartender may distribute more expensive drinks, i.e., drinks associated with more valuable awards. A bonus sequence may also include more expensive drinks and more valuable awards. The bartender 240 serves drinks until: (i) each choice is generated its allotted number of times, as illustrated in connection with the method 100; or (ii) gaming device 10 generates a first choice its allotted number of times.

[0090] While the present invention is described in connection with what is presently considered to be the most practical and preferred embodiments, it should be appreciated that the invention is not limited to the disclosed



embodiments, and is intended to cover various modifications and equivalent arrangements included within the spirit and scope of the claims. Modifications and variations in the present invention may be made without departing from the novel aspects of the invention as defined in the claims, and this application is limited only by the scope of the claims.

The invention is claimed as follows:

1. A gaming device comprising:
  - a display; and
  - a processor in communication with the display, said display and said processor adapted to provide:
    - a first round including,
      - a choice selected by the player from a set of choices displayed by the display,
      - a choice generated by the processor from the set of choices; and
      - an award provided to the player based on the choice generated by the processor; and
    - a second round displayed to the player by the display after the first round if the player selected choice is not the same as the processor generated choice.
2. The gaming device of claim 1, which includes an allotted number associated with each choice, wherein the processor generates choices in the first round, and wherein the round ends when one of the choices in the set has been generated the allotted number of times associated with the one choice.
3. The gaming device of claim 1, which includes an allotted number associated with each choice of the set, wherein the processor generates choices in the first round, and wherein the first round ends when each choice has been generated the allotted number of times associated with each choice.
4. The gaming device of claim 1, which includes a value generated with each generation of one of the choices of the set, wherein the award for the first round includes the values generated before the first round ends.
5. The gaming device of claim 1, which includes a value generated with each generation of one of the choices of the set, wherein the award for the first round includes the values generated each time the player selected choice is generated before the first round ends.
6. The gaming device of claim 1, wherein the second round displays the plurality of choices displayed in the first round except the choice generated by the processor.
7. The gaming device of claim 1, which includes a randomly generated modifier event that: decreases an amount of times that at least one choice has been generated with respect to the allotted number associated with said choice; or multiplies an award generated for the player.
8. The gaming device of claim 1, wherein the second round includes:
  - at least one award provided to the player; a choice selected by the player from a second set of choices displayed by the display; and a choice generated by the processor from the second set.
9. The gaming device of claim 8, wherein awards generated in the second round are larger, on average, than awards generated in the first round.

10. The gaming device of claim 8, which includes a third round displayed to the player after the second round if, in the second round, the player selected choice is not the same as the choice generated by the processor.

11. The gaming device of claim 10, wherein the third round includes the same plurality of choices displayed by the display in the second round except the choice generated by the processor in the second round.

12. The gaming device of claim 1, which includes a plurality of rounds and a bonus award provided to the player if, in each round, the player selected choice is not the same as the choice generated by the processor.

13. A gaming device comprising:

- a display;
- a processor in communication with the display, said processor and display adapted to provide:
  - a first round including,
    - a set of choices displayed by the display and an allotted number associated with each choice;
    - a choice selected by the player from the set, and
    - a plurality of choices generated by the processor from the set, the generations occurring until one of the choices in the set has been generated the allotted number of times associated with the one choice, and
  - an award provided to the player; and
  - a second round displayed to the player after the first round if the player selected choice is not the same as the one choice generated the allotted number of times.

14. A gaming device comprising:

- a display;
- a processor in communication with the display, said processor and said display adapted to provide:
  - a first round including,
    - a set of choices displayed by the display and an allotted number associated with each choice;
    - a choice selected by the player from the set, and
    - a plurality of choices generated by the processor from the set, the generations occurring until each choice has been generated the allotted number of times associated with each choice,
  - a randomly designated choice, and
  - an award provided to the player; and
  - a second round displayed to the player after the first round if the player selected choice is not the same as the randomly designated choice.

15. A gaming device comprising:

- a display;
- a processor in communication with the display, said processor and said display adapted to provide:
  - a first round including,
    - a set of choices displayed by the display,

a choice selected from the set by the player, and  
 at least one choice generated by the processor, the  
 generations occurring until one of the choices is  
 picked from the set by the processor, and  
 an award provided to the player; and  
 a second round displayed to the player if the player  
 selected choice is not the same as the choice picked  
 by the processor.

**16.** The gaming device of claim 15, which includes an  
 allotted number associated with each choice, wherein  
 the processor generates choices in the sequence, and  
 wherein the choice picked by the processor is the  
 first choice to be generated the allotted number  
 of times associated with the choice.

**17.** The gaming device of claim 16, which includes a  
 randomly generated modifier event that decreases an  
 amount of times that one of the choices has been  
 generated with respect to the allotted number  
 associated with the one choice.

**18.** The gaming device of claim 16, which includes a  
 randomly generated modifier event that decreases an  
 amount of times that each choice has been generated  
 with respect to the allotted number associated with  
 each choice.

**19.** The gaming device of claim 16, which includes a  
 randomly generated modifier event that multiplies  
 the award generated for the player.

**20.** The gaming device of claim 15, which includes a  
 value generated with each generation of a choice,  
 wherein the award for the first round includes  
 values generated before the first round ends.

**21.** The gaming device of claim 20, wherein the  
 award for the first round includes only values  
 generated when the player selected choice is  
 generated.

**22.** The gaming device of claim 15, which includes a  
 plurality of rounds, wherein each round, except  
 the first round, excludes the choice picked by  
 the processor in the preceding round from the  
 set on the display.

**23.** The gaming device of claim 15, which includes  
 a plurality of rounds, wherein awards generated  
 in a succeeding round are larger, on average,  
 than awards generated in a preceding round.

**24.** The gaming device of claim 15, which includes  
 a plurality of rounds and a bonus award provided  
 to the player if, in each round, the player  
 selected choice is not the same as the choice  
 generated by the processor.

**25.** A gaming device comprising:

a display;

a processor in communication with the display,  
 said processor and said display adapted to provide:

a plurality of choices displayed by the display;

an allotted number associated with each choice;

a sequence displayed by the display in which  
 the processor generates choices until one  
 choice is generated the allotted number of  
 times associated with said choice; and

an award that depends on a total number of  
 times that the processor generates the choices  
 before the one choice is generated its allotted  
 number of times.

**26.** The gaming device of claim 25, wherein the  
 sequence is adapted so that the processor  
 generates choices until each choice is  
 generated the allotted number of times  
 associated with said choice.

**27.** The gaming device of claim 25, wherein the  
 award depends on a total number of times that  
 the processor generates the choices before  
 each choice has been generated the allotted  
 number of times associated with each choice.

**28.** A gaming device including a game controlled  
 by a processor and displayed by a processor  
 controlled display device, the game having a  
 plurality of rounds, wherein each round  
 comprises:

a plurality of choices, wherein one of the  
 choices is selected by a player and one of  
 the choices is selected by the processor;

an allotted number assigned to each choice; and

awards associated with the choices selected  
 by the player, wherein the processor selects  
 choices and provides awards associated with  
 at least one selected choice until the  
 processor generates one of the choices its  
 associated allotted number of times, after  
 which the processor provides another round  
 if the choice selected by the player is not  
 the choice selected by the processor.

**29.** The gaming device of claim 28, wherein  
 the choice selected by the processor is the  
 choice which the processor generated its  
 associated allotted number of times.

**30.** The gaming device of claim 28, wherein  
 the choice selected by the processor is  
 randomly determined by the processor  
 after the processor generates the choice  
 its associated allotted number of times.

**31.** A gaming device including a game  
 controlled by a processor and displayed  
 by a processor controlled display device,  
 the game having a plurality of rounds,  
 wherein each round comprises:

a plurality of choices, wherein one of the  
 choices is selected by a player and one of  
 the choices is selected by the processor;

an allotted number assigned to each choice; and

awards associated with the choices selected  
 by the player, wherein the processor  
 selects choices and provides the awards  
 associated with at least one of the  
 selected choices until the processor  
 generates one of the choices its  
 associated allotted number of times,  
 after which, if the choice selected by  
 the player is not the choice selected  
 by the processor, the processor  
 provides another round having said  
 choices except any previous choices  
 selected by the processor.

\* \* \* \* \*