



US 20140203135A1

(19) **United States**

(12) **Patent Application Publication**

Walter

(10) **Pub. No.: US 2014/0203135 A1**

(43) **Pub. Date: Jul. 24, 2014**

(54) **BALLOON WITH DEFLATION AND MANEUVERING PORT**

**Publication Classification**

(71) Applicant: **Forrest L. Walter**, Spokane Valley, WA (US)

(51) **Int. Cl.**  
**B64D 47/00** (2006.01)

(72) Inventor: **Forrest L. Walter**, Spokane Valley, WA (US)

(52) **U.S. Cl.**  
CPC ..... **B64D 47/00** (2013.01)  
USPC ..... **244/31**

(21) Appl. No.: **13/744,764**

(57) **ABSTRACT**

A hot air balloon with an adjustable deflation port at its upper end which can be selectively opened and closed on the ground and during flight. The positive control of the port by the operator of the balloon in the basket allows the deflation port to be adjusted at any position from full open to fully closed or held in intermediate positions as desired.

(22) Filed: **Jan. 18, 2013**

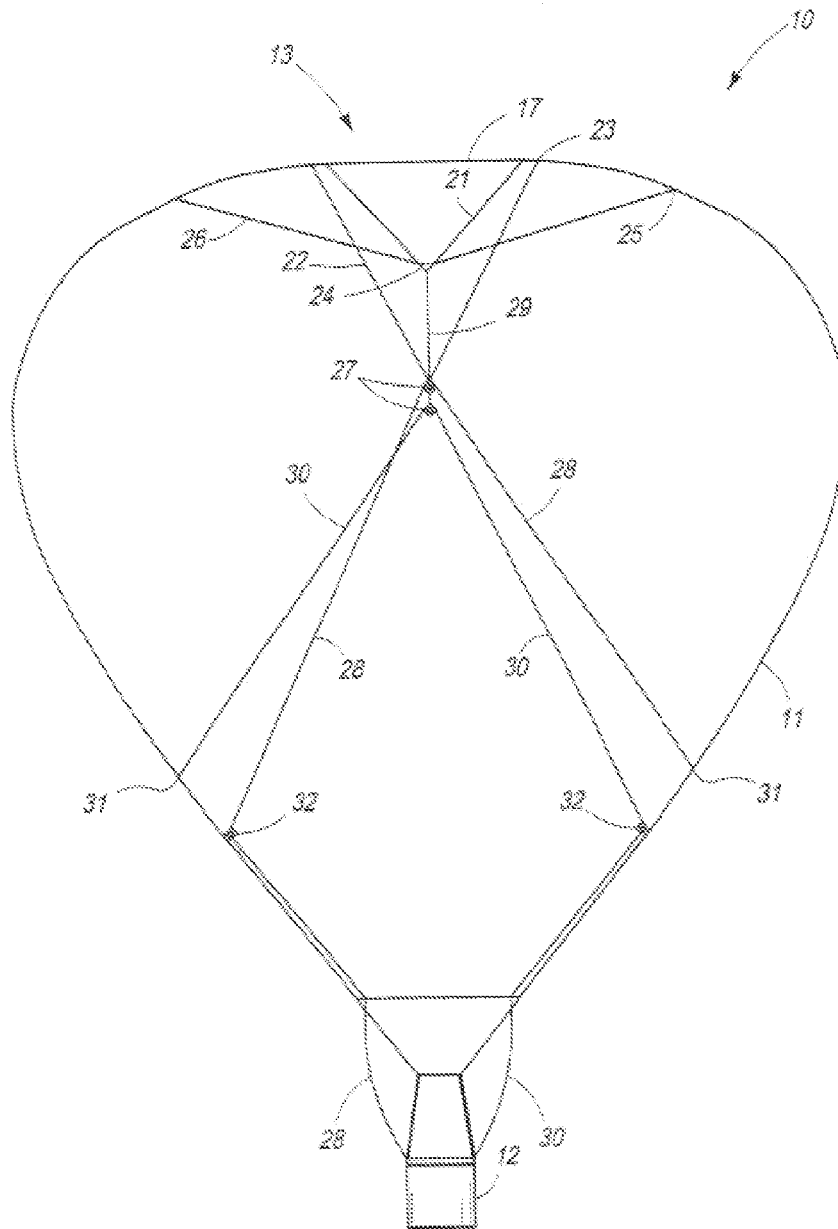

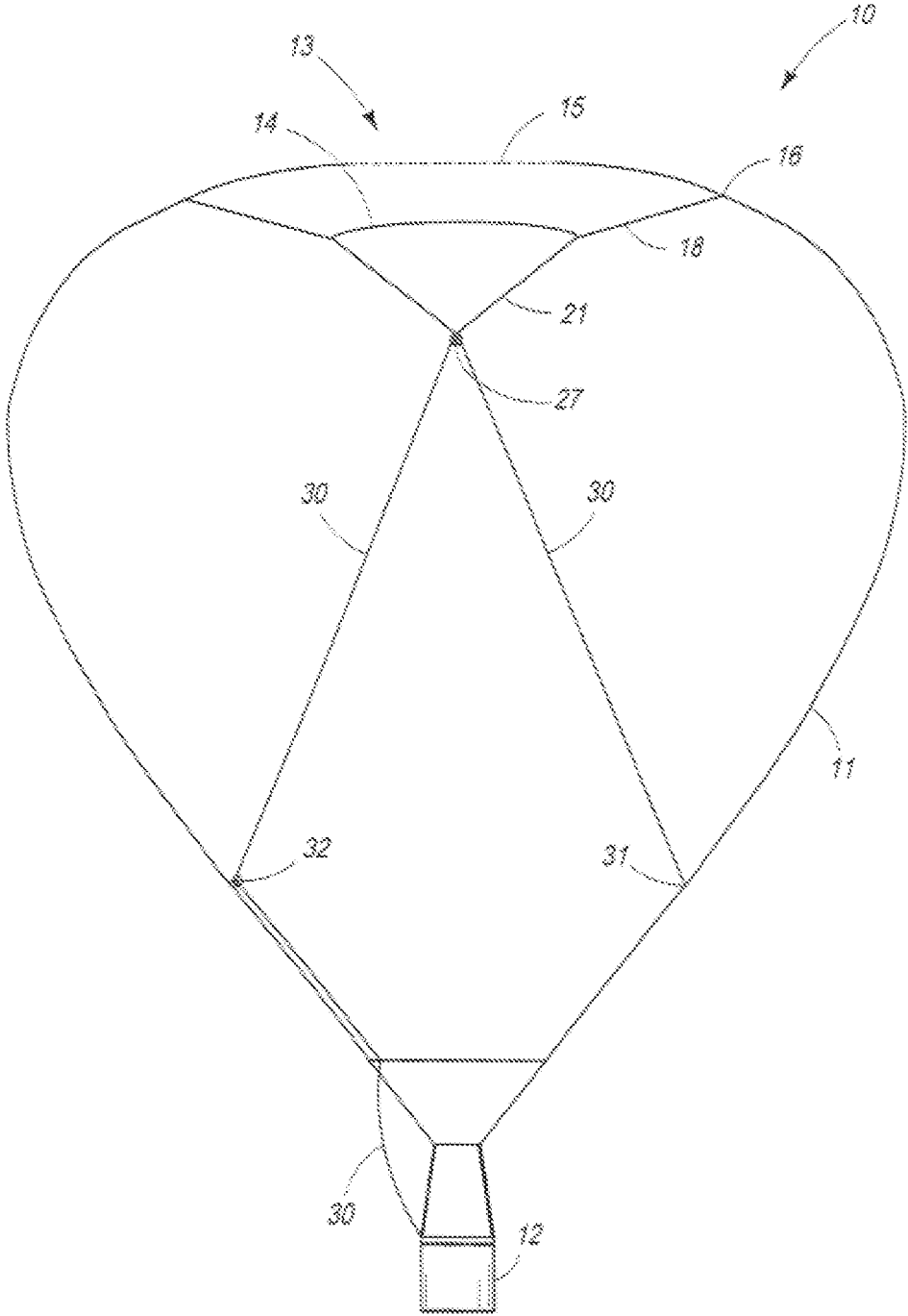

**FIG. 1**  
*Prior Art*

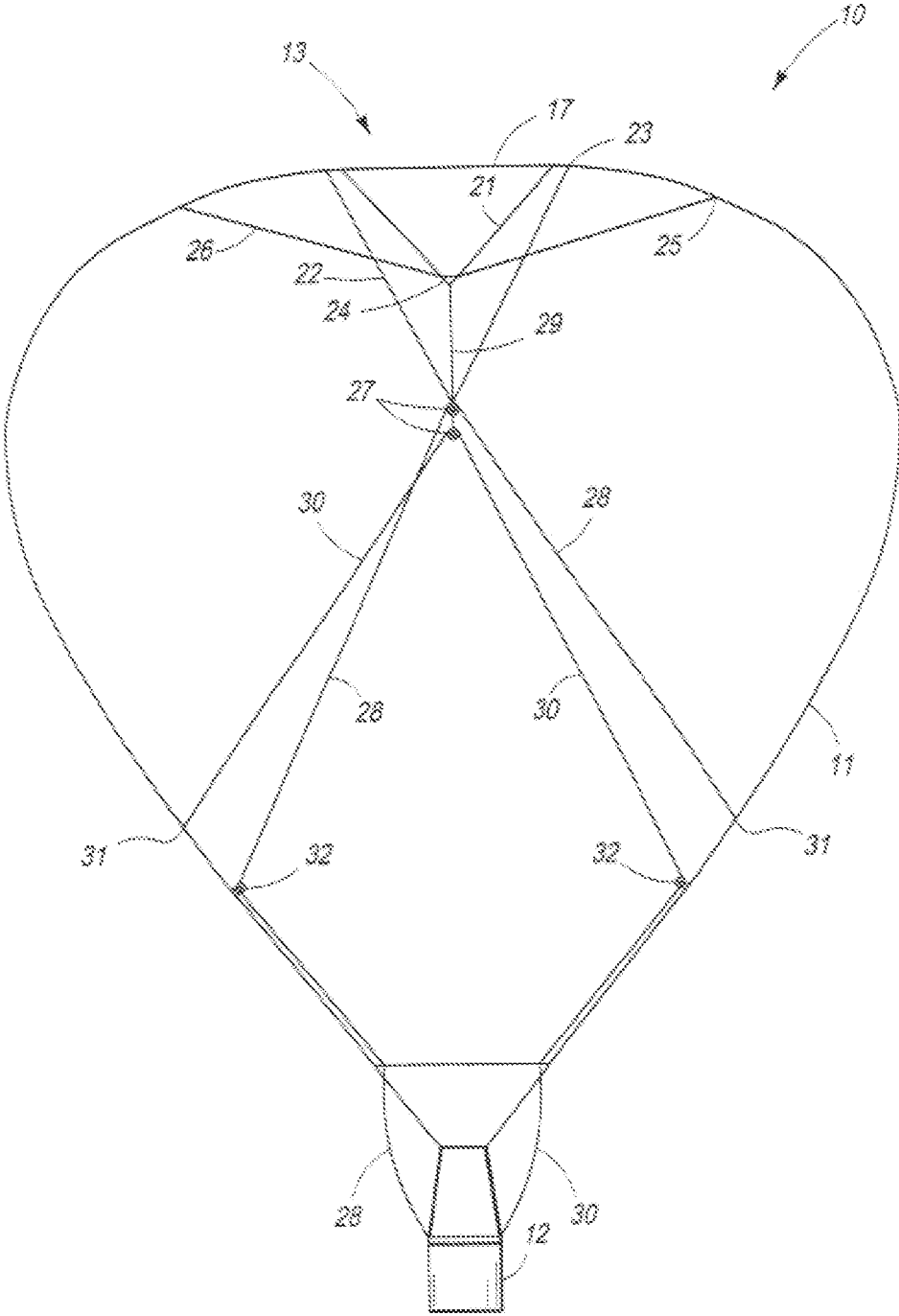

FIG. 2

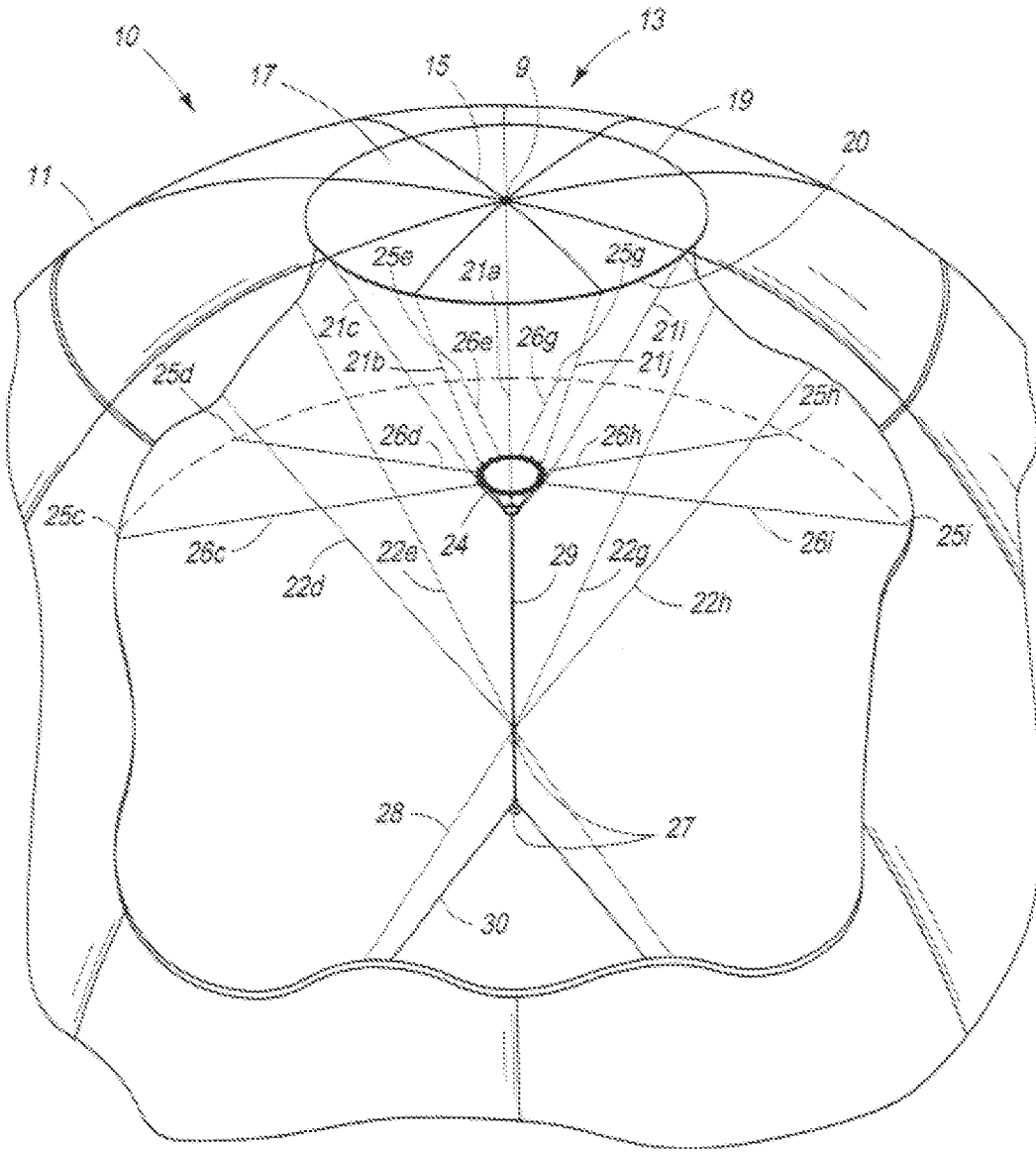

FIG. 3

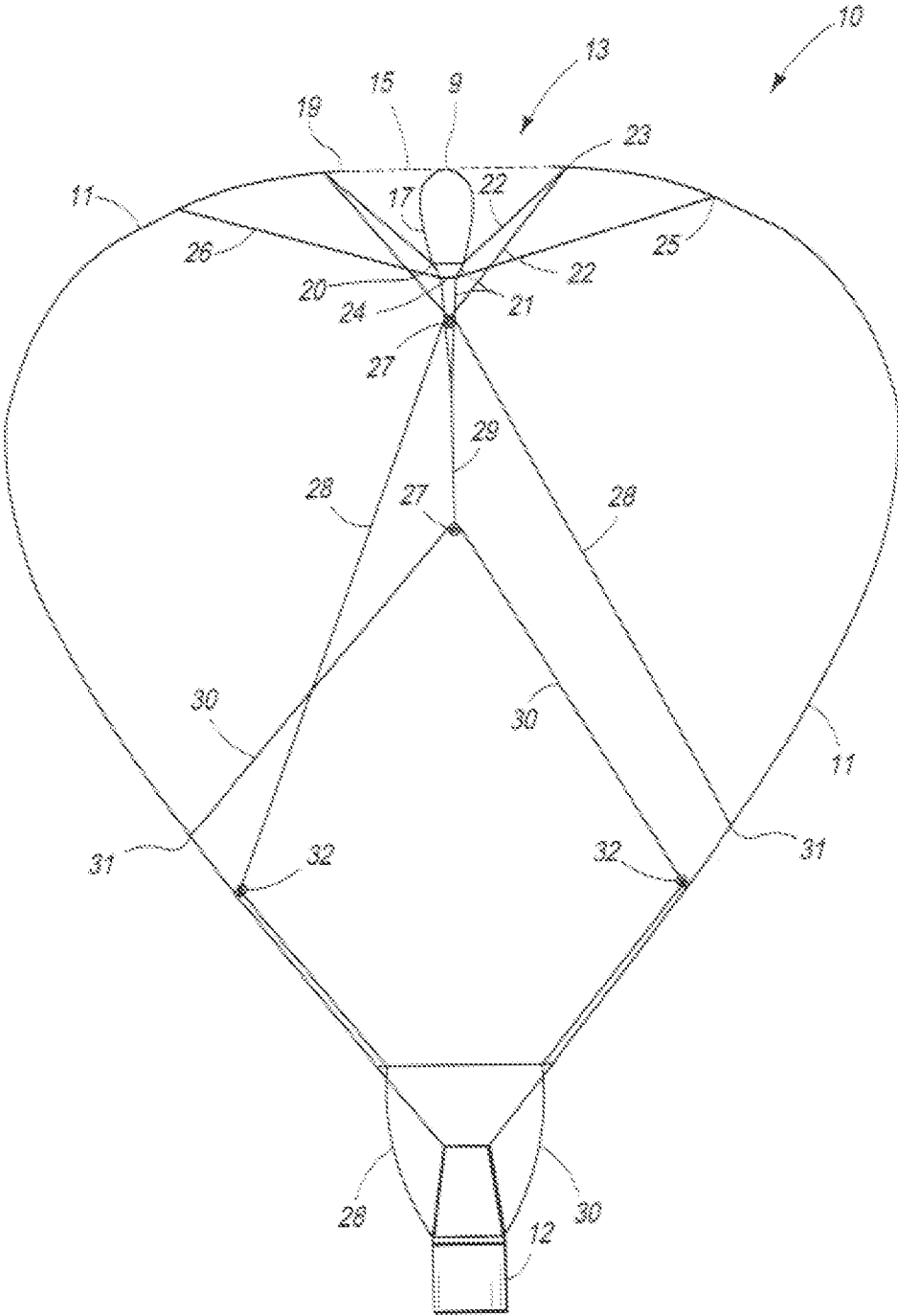

FIG. 4

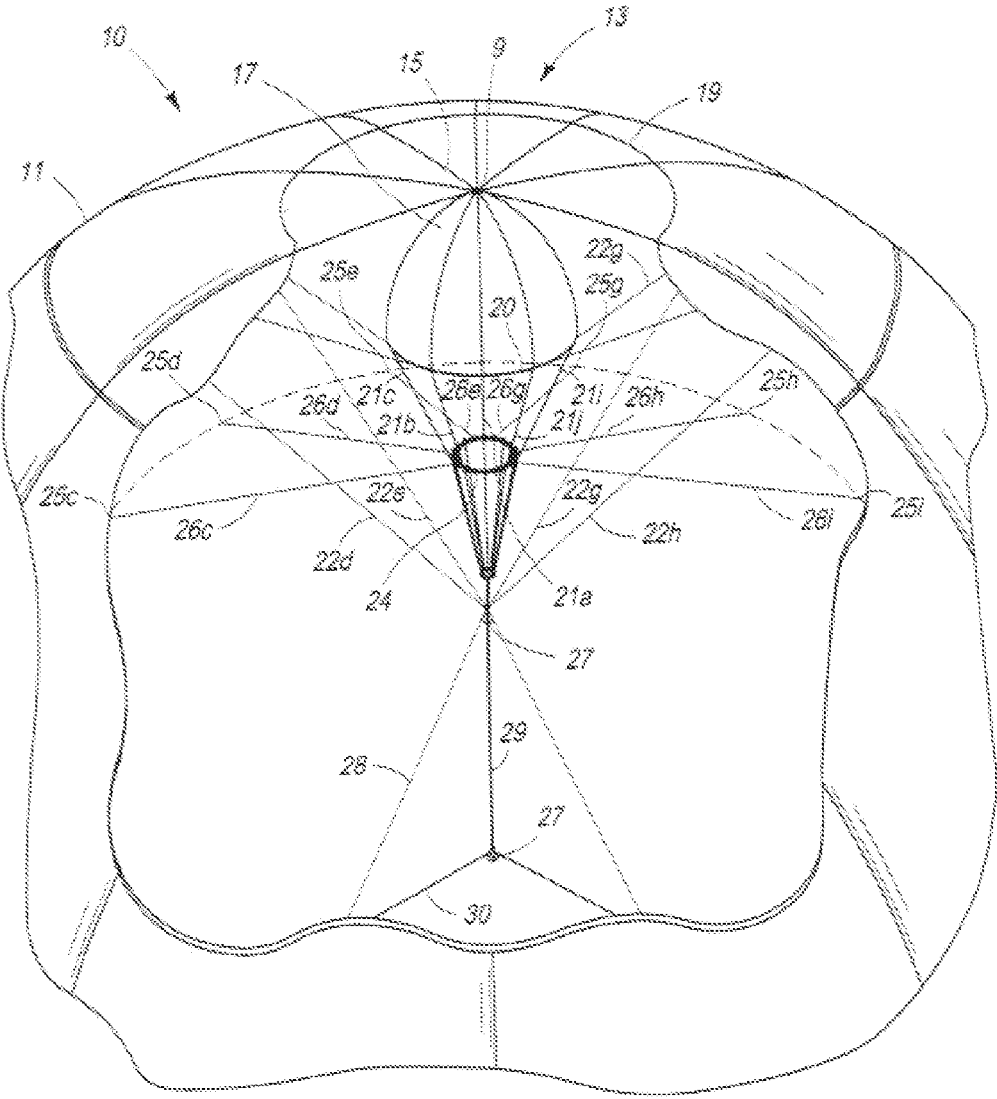

FIG. 5

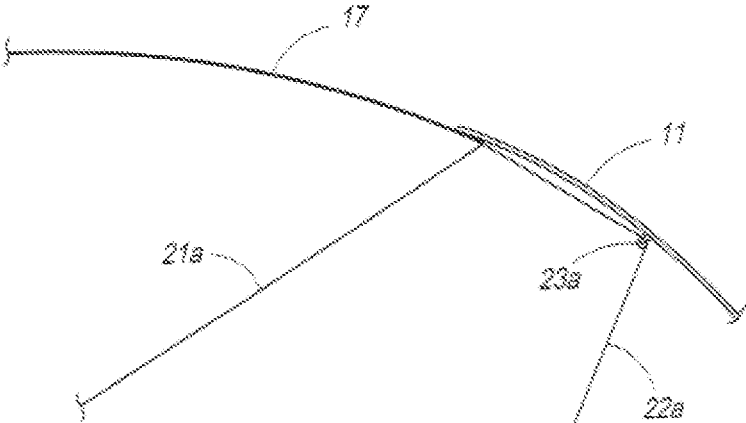

FIG. 6

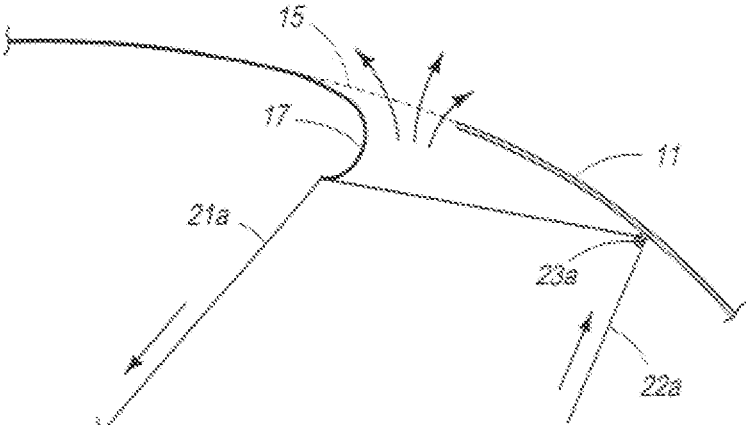

FIG. 7A

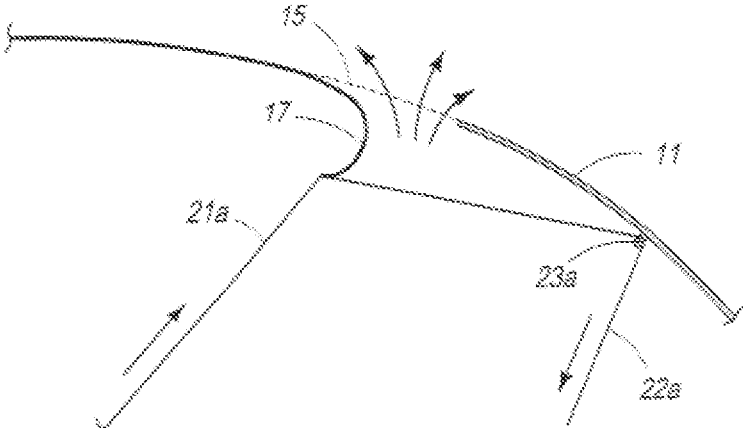
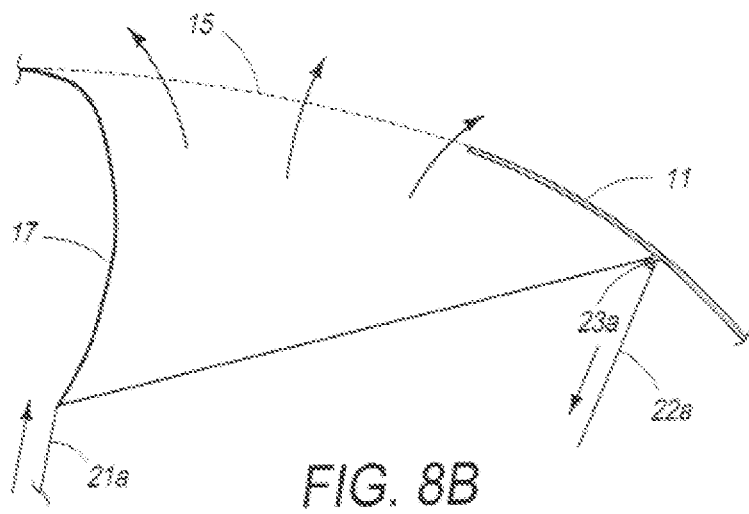
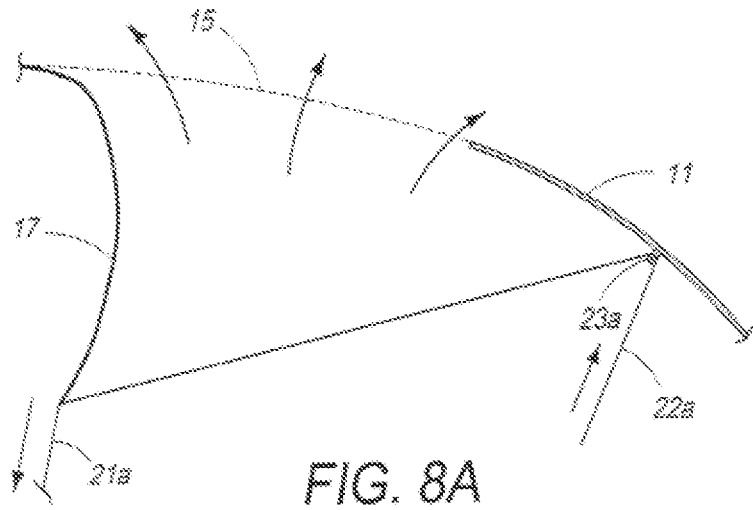

FIG. 7B





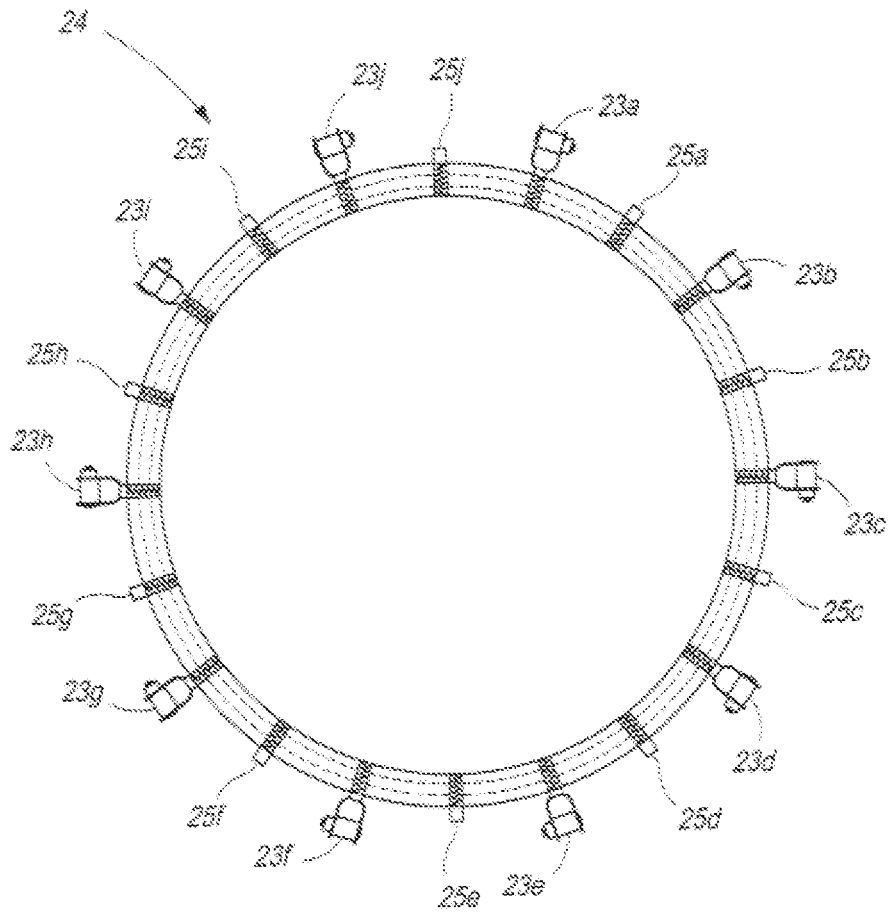

FIG. 9

## BALLOON WITH DEFLATION AND MANEUVERING PORT

### BACKGROUND OF THE INVENTION

**[0001]** 1. Field of the Invention

**[0002]** This invention relates in general to hot air balloons. The invention in particular relates to an improved venting process for the hot air used to control vertical ascent, descents and deflation of hot air balloons.

**[0003]** 2. Description of the Prior Art

**[0004]** As hot air balloons have become more and more popular, they have been constructed with heaters beneath their lower opening so as to heat the air within the balloon envelope. It is necessary and desirable when the balloon lands to rapidly deflate the balloon so that the envelope will collapse thus preventing it from being blown across the ground by the wind. It is also desirable to have a maneuvering vent for performing both vertical ascents and descents of the craft while in the air.

**[0005]** Prior art deflation ports provided openings which releases hot air from the top of the balloon envelope to deflate and/or maneuver the balloon vertically. Such deflation port systems which are used more than all others are called the "parachute" deflation port and vent system. The parachute deflation port design consists of a circular opening located at the top or apex of the balloon envelope. In the deflation port opening are a plurality of tape webs which extend from the envelope gores over the center of the deflation port opening. A parachute is a circular piece of material which is made from the same fabric as the balloon envelope. The parachute is larger in diameter than the deflation port opening. The parachute is held in the envelope by a plurality of centering lines which are attached about the outer edge of the parachute and the opposite ends of the plurality of centering lines are attached to the envelope gore seams. When the balloon is inflated with air the internal air pressure pushes the parachute against the apex webbing so that the parachute seals the envelope about the edges of the deflation port opening. The parachute also has a plurality of shroud lines that are attached about the outer edges of the parachute at the same locations as the plurality of centering lines. The shroud lines do not attach to the balloon envelope. They extend down inside of envelope and meet at a central location directly below the center of the parachute. Where the shroud lines are joined together and a pulley is attached to them. A parachute deflation line has one end attached to an inside gore seam near the bottom of the balloon envelope and passes through the pulley. The other end of the deflation line extends downward passing through a second pulley which is attached to balloon envelope at a location which is opposite to the location of the deflation line termination point. The deflation line passes through the pulley and then extends down the balloon envelope and to the basket.

**[0006]** In operation when the balloon is inflated the internal pressure inside of the envelope pushes the parachute fabric against the apex webbing thus sealing the deflation port opening. To release air for venting and/or deflation purposes the pilot in the basket pulls down on the deflation line, which pulls the parachute down and away from the apex webbing thus allowing air to escape from the envelope. When the pilot releases the deflation port line the internal pressure inside the envelope pushes the parachute up resealing the deflation port. Thus vertical control of the balloon in flight is accomplished.

So as to terminate the flight the pilot pulls down on the deflation port line and holds it until the envelope deflates.

### SUMMARY OF THE INVENTION

**[0007]** The present invention relates to a hot air balloon having a deflation port that can also be used as a maneuvering vent which can be selectively opened or closed and adjusted to varying positions from the basket of the balloon while in flight as well as when the balloon is on the ground. The deflation port comprises a circular deflation valve with its center point attached to the center of the apex webbing at the deflation port opening. The deflation valve has two pluralities of shroud lines. The first plurality of shroud lines control the deflating and venting of the balloon. The second plurality of shroud lines reseal the deflation valve once its open. The deflation shroud plurality of shroud lines are attached to the outer edge of the deflation valve and extend downward to a shroud load assembly which is located a short distance below the center of the deflation valve. The deflation lines go through a plurality of pulleys mounted on the shroud load assembly and are then connected together.

**[0008]** The plurality of resealing shroud lines are attached to the outer edges of deflation valve and each pass through another plurality of pulleys which are located on the inside envelope gore seams a short distance from the deflation port opening. The resealing lines then pass down into the envelope and are connected together at a distance below the plurality of deflation shroud line. A deflation line is attached to the plurality of deflation shroud lines and extends down to the basket. A reseal control line is attached to the plurality of reseal shroud lines and extend down to the basket. When the pilot pulls the deflation control line the deflation valve's outer edges are pulled inwardly and down away from the deflation port edge which allows air to escape from the envelope. To close the deflation valve the pilot releases the deflation control line and pulls down on the reseal control line which pulls the outer edges of the deflation valve up and back into the deflation port opening and the internal air pressure in the envelope pushes the deflation valve against the apex webbing thus resealing the deflation valve back into the deflation port opening. This invention allows venting by peeling back the outside edges of the deflation valve moving it away and down, from the apex webbing and deflation port opening. This "peel back" action has three advantages to this invention over present designs; 1) the ease of operation. The deflation valve is pulled inward and down from the apex webbing and deflation port. The amount of force required to activate the deflation line is substantially less than a free floating parachute design. 2) By peeling back and pulling the deflation valve inward and down the air exits from the envelope faster than in prior art because the air does not have to travel around a parachute. 3) By looking up into the envelope while venting the pilot can see the size of the vent opening and can better determine the vent times for maneuvers.

### BRIEF DESCRIPTION OF THE DRAWINGS

**[0009]** FIG. 1 is a schematic cross-section view of atypical hot air balloon including a standard parachute vent. The parachute is shown in the open or deflating position:

**[0010]** FIG. 2 is a cross-section view of the hot air balloon envelope incorporating the venting design of the present invention with the vent in the closed position;

[0011] FIG. 3 is a detailed cutaway view of the hot air balloon envelope incorporating the venting design of the present invention with the vent in the closed position.

[0012] FIG. 4 is a cross-section view of the hot air balloon envelope incorporating the venting design of the present invention with the vent in the open position;

[0013] FIG. 5 is a detailed cutaway view of the hot air balloon envelope incorporating the venting design of the present invention with the vent in the open position;

[0014] FIG. 6 is an enlarged cross-section of the upper envelope venting system showing the vent in the closed position.

[0015] FIG. 7A is an enlarged cross-section of the upper envelope deflation system showing the deflation valve in a peel away venting position with a downward exerting force on the deflation shroud line allowing air to be vented.

[0016] FIG. 7B is an enlarged cross-section of the upper envelope deflation system showing the deflation valve in a peel away venting position. The downward force on the reseal shroud line exerts an up and outward force on the deflation valve's outer edges starting the resealing of the deflation valve back into the deflation port opening.

[0017] FIG. 8A is an enlarged cross-section of the upper envelope deflation system showing the deflation valve in the open position with the force on the deflation shroud line in the downward direction to hold the deflation valve open.

[0018] FIG. 8B is an enlarged cross-section of the upper envelope deflation system showing the deflation valve in the open position. The downward force on the reseal shroud line exerts an up and outward force on the deflation valve's outer edges starting the resealing of the deflation valve back into the deflation port opening.

[0019] FIG. 9 illustrates the Center shroud load assembly.

#### DESCRIPTION OF THE PREFERRED EMBODIMENTS

[0020] FIG. 1 shows the prior art parachute vent deflation port system.

[0021] A hot air balloon 10 consist an envelope 11 comprising a plurality of gores and has a deflation port 13 at the upper end and a basket 12 at the lower end where the pilot or operator rides. The deflation port 13 is opened and closed by means of a circular parachute valve 14 located beneath the apex webbing 15 located in the deflation port opening. Centering lines 18 keep the parachute 14 positioned under the apex webbing 15 and allow a range of movement of the valve from pressing up against the apex webbing to dropping directly down in the envelope 11. By opening the deflation port the parachute 14 allows the air from inside the envelope 11 to escape around the parachute 14 and out the deflation port opening. The centering lines 18 have fixed end attached about the parachute's outer edges, their other ends are attached to the envelope's gore seams 16 about the opening and a substantial distance from the opening. The shroud lines 21 descend downward from the outer edges of the parachute 14 and are connected to a pulley assembly 27 located directly below the center of the parachute 14. The parachute deflation line 30 passes through a pulley of assembly 27 and one end of the line is attached to the envelope bridle assembly 31 and other end passes through a bridle pulley assembly 32 which is located on the other side of the inner envelope. To operate the deflation system the pilot or operator pulls downwardly on the deflation line 30 which in turn pulls down on the plurality of shroud lines 21 which pulls the parachute 14 away from the

apex webbing 15 and allows air to escape round the parachute's outer edge to exit the envelope through the deflation port opening 13. The pilot uses a pull on the deflation line 30 to vent air from the envelope. To close or reseal the parachute 14 the pilot releases the deflation line 30 and the internal air pressure pushes the parachute 14 up against the apex webbing 15 sealing it back into the deflation port opening. If the pilot wants to terminate the flight a hard hand over hand pull is required with the pilot holding onto the deflation line 30 until the envelope is deflated.

[0022] FIGS. 2 through 9 shows preferred embodiments of the invention. FIG. 2 illustrates a balloon 10 of the invention comprising an envelope 11 and a basket 12 supported therefrom with an adjustable deflation port 13. A deflation valve 17 is mounted in the upper end of the balloon. FIG. 2 shows the deflation valve 17 closed. The deflation port system comprises a deflation valve 17 which has its center 9 connected to the center point of the apex webbing 15 in the venting opening. The connection of the deflation valve 17 to the apex webbing 15 results that the deflation valve 17 is not free floating. The deflation valve 17 is connected to two pluralities of shroud lines. One plurality of shroud lines are short and are deflation shroud lines 21a-21j which descend down to a shroud load assembly 24 shown in detail in FIG. 9 located directly below the deflation valve 17. The shroud load assembly 24 is a fabric disk with a plurality of pulleys 23a-23j as shown in FIG. 9. Attachment points 25a-25j are sewn around its perimeter between pulleys 23a-23j. The pulleys 23 and attachment points 25 generally correspond to the number of gores in the envelope. A plurality of centering lines 26a-26j are attached to the shroud load assembly 24 and to the inside gore seams 25 so as to suspend the shroud load assembly 24 in the center of the envelope directly below the deflation valve. The deflation valve shroud lines 21a-21j run through pulleys 23a-23j on the shroud load assembly 24 and are joined together. A jumper line 29 is attached to the shroud line 21a-21j and has pulley 27 at its lower end extending toward the basket. A deflation line 30 runs through pulley 27 and one end of line 30 is attached to a bridle assembly 31 located near the mouth of the envelope. The other end of the deflation line 30 goes through the bridle pulley assembly 32 located on the opposite side of the envelope and extends down to the basket 12 where it is attached at a suitable location so that wherein it can be easily reached by the pilot of the balloon for operation.

[0023] The second plurality of shroud lines are called the resealing shrouds 22a-22j extend from the deflation valve's outer edges down inside the envelope 11 to pulleys 23a-23j sewn to each gore seam. (See FIGS. 6, 7A, 7B, 8 & 8A) The lines 22 pass through the pulleys 23 and descend downward and are joined together just above pulley 27 mounted on the jumper rope 29. A second pulley 27 is attached to the shroud group. A resealing line 28 runs through pulley 27 and one is end attached to a bridle assembly 31 located up from the mouth of the envelope. The other end to resealing line 28 goes down the opposite side of the envelope and runs through a bridle pulley assembly 32 and continues down the envelope into the basket 12 where it is tied off at a second suitable location wherein it can be easily reached by the pilot of the balloon.

[0024] The deflation port operates in the following manner. The pilot pulls down on the deflation line 30 which causes the plurality of shroud lines 21 to pull the deflation valve's 17 outer edge down to peel it away from the apex webbing 15 and deflation port 13 which releases air through the deflation port

of the envelope 11. (See FIGS. 4, 5, 7A, 7B, 8A & 8B) Both plurality of shroud lines are attached to the deflation valve's outer edges, when the deflation valve 17 is peeled away and pulled down, the resealing lines 22 along with the reseating line 28 are pulled up into the envelope. (See FIGS. 3, 5, 6, 7A & 8A) To reseal the deflation valve 17 back into the deflation port opening 13, the pilot releases deflation line 30 and pulls down on the resealing line 28. Pulling down on the resealing line 28 reverses the deflation process by pulling deflation line 30, shroud lines 21 and deflation valve 17 up repositioning the deflation valve 17 back against the apex webbing 15 where the internal air pressure seals it into the deflation port opening 13. (See FIGS. 7B & 8B)

[0025] Thus, it is seen that the present invention provides novel deflation and venting of the envelope through the valve which when activated is peeled away from the deflation port opening. This peeling action changes the valve's shape from a flat disk to a shape more like a jelly fish. This peeling action and the changing of its shape lowers the amount of force placed upon the valve by the balloon envelope's internal air pressure allowing the valve to be operated much easier than prior art parachute deflation systems. The present invention can be selectively operated so as to either open or close or hold in intermediate positions as desired.

[0026] Although the invention has been described with respect to preferred embodiments, it is not to be limited as changes and modifications may be made therein which are within the full intended scope as defined by the appended claims.

LEGEND FOR FIGS. 1 THRU 9—PAGES 1/9  
THRU 9/9

- [0027] 9.—Location where Deflation. Valve is attached to center point of Apex Webbing
- [0028] 10.—Balloon
- [0029] 11.—Envelope
- [0030] 12.—Basket
- [0031] 13.—Deflation port

- [0032] 14.—Parachute
- [0033] 15.—Apex Webbing
- [0034] 16.—Parachute attachment point prior art
- [0035] 17. Deflation Valve
- [0036] 18.—Parachute Centering Line
- [0037] 19.—Deflation Port Edge
- [0038] 20.—Edge of the Deflation Valve
- [0039] 21a thru 21j.—Deflation Shroud Line
- [0040] 22a thru 22j.—Resealing Shroud Line
- [0041] 23a thru 23j.—Shroud Pulley
- [0042] 24.—Shroud Load Assembly
- [0043] 25a thru 25j—Load Assembly Line Attachment Points
- [0044] 26a thru 26j—Load Assembly Centering Line
- [0045] 22.—Deflation Line Pulley
- [0046] 28.—Repealing Line
- [0047] 29.—Jumper line
- [0048] 30.—Deflation Line
- [0049] 31.—Bridle Assembly
- [0050] 32.—Bridle Pulley Assembly

1. A deflation valve mounted, is a deflation port of a balloon which has gore webbing extending there through said deflation valve attached to said gore webbing within deflation pen and means for peelings at least one edge of said deflation valve away from said deflation port.

2. A deflation valve according to claim 1 including means for repealing said deflation valve in said deflation port opening to seal it.

3. A deflation valve according to claim 2 wherein said means for peeling includes a plurality of shroud hues connected to outer edges of said deflation valve for peeling said deflation valve from said deflation port.

4. A deflation valve according to claim 2 wherein said means for resetting said deflation valve including a plurality of reseating shroud connected to outer edge of said deflation valve and which can be when activated reseal said deflation valve in said deflation port.

\* \* \* \* \*