



(19) **United States**

(12) **Patent Application Publication**
HETZLER et al.

(10) **Pub. No.: US 2021/0153590 A1**

(43) **Pub. Date: May 27, 2021**

(54) **SYSTEM FOR MITIGATING MUSCULOSKELETAL STRESSES FROM HEAD-RELATED MOMENTS EXERTED ON A PERSON**

Publication Classification

(51) **Int. Cl.**
A42B 3/04 (2006.01)
(52) **U.S. Cl.**
CPC *A42B 3/0473* (2013.01); *A42B 3/0406* (2013.01)

(71) Applicant: **Thumbprint Solutions Inc.**, Stouffville (CA)

(72) Inventors: **Markus HETZLER**, Stouffville (CA);
Stephen FISCHER, Kingston (CA);
Joan STEVENSON, Kingston (CA);
Susan REID, Kingston (CA)

(57) **ABSTRACT**

In an aspect, a stress mitigation system is provided for mitigating stresses in a wearer of a headgear configured to apply a load on the wearer that is offset from a CG of a wearer's head. The system includes a first and second cable segments, and a tensioning device. Each cable segment has a first end and a second end, mounted to one of the headgear and the bodywear member respectively. The first ends are laterally inboard and vertically spaced from the second ends. During pivoting of the head in a first direction, the first cable segment changes orientation towards vertical and the second cable segment changes orientation towards horizontal, and during pivoting movement of the head in a second direction. The tensioning device increases tension in any cable segment that changes orientation towards vertical, and reduces tension in any cable segment that changes orientation towards horizontal.

(21) Appl. No.: **17/165,632**

(22) Filed: **Feb. 2, 2021**

Related U.S. Application Data

(63) Continuation of application No. 15/510,042, filed on Mar. 9, 2017, now Pat. No. 10,905,185, filed as application No. PCT/CA2015/050877 on Sep. 10, 2015.
(60) Provisional application No. 62/048,650, filed on Sep. 10, 2014.

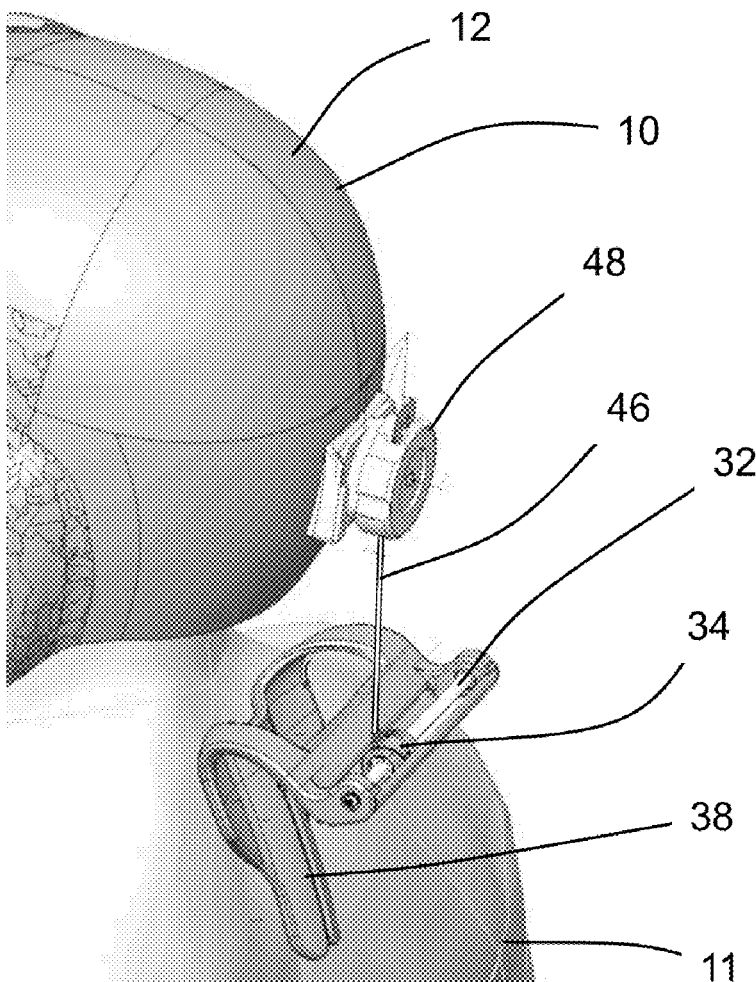

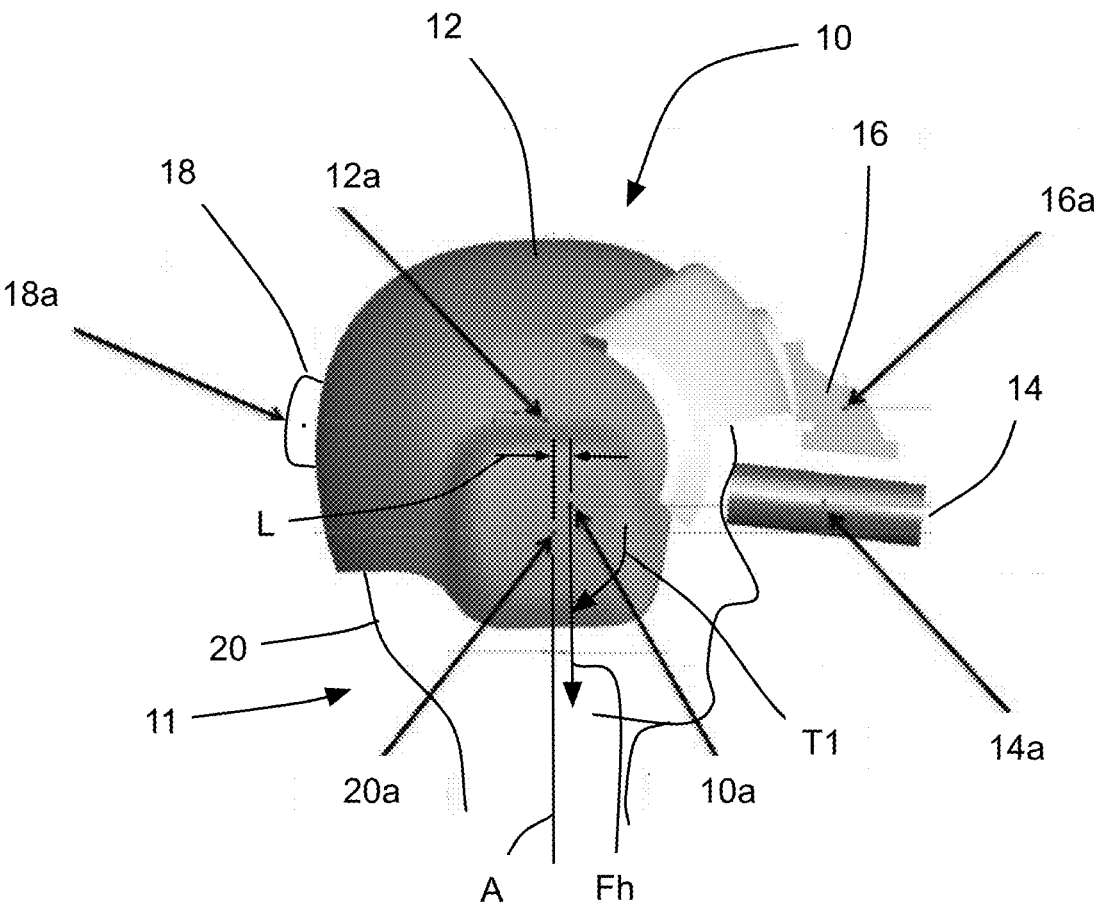

FIG. 1

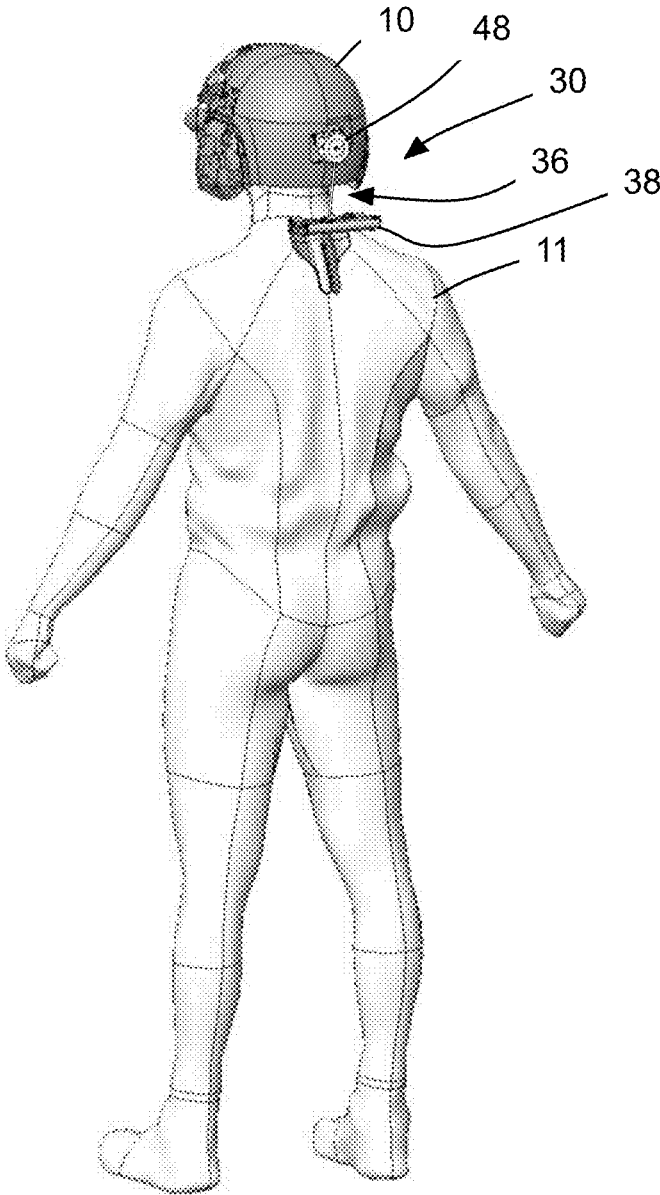

FIG. 2

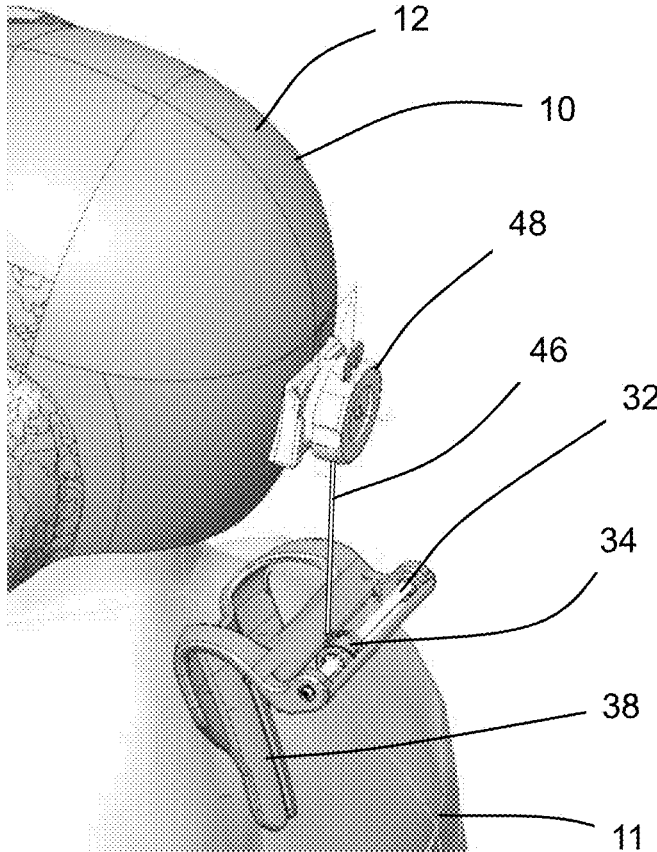

FIG. 3

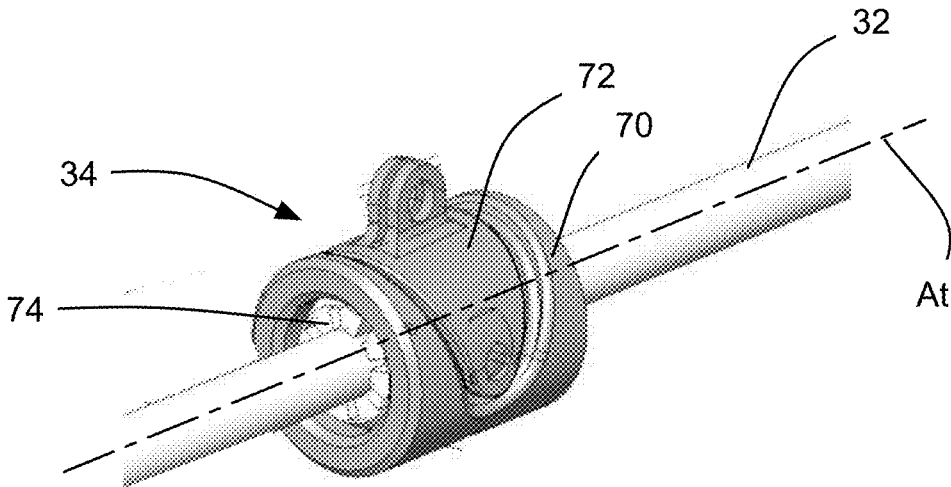

FIG. 4

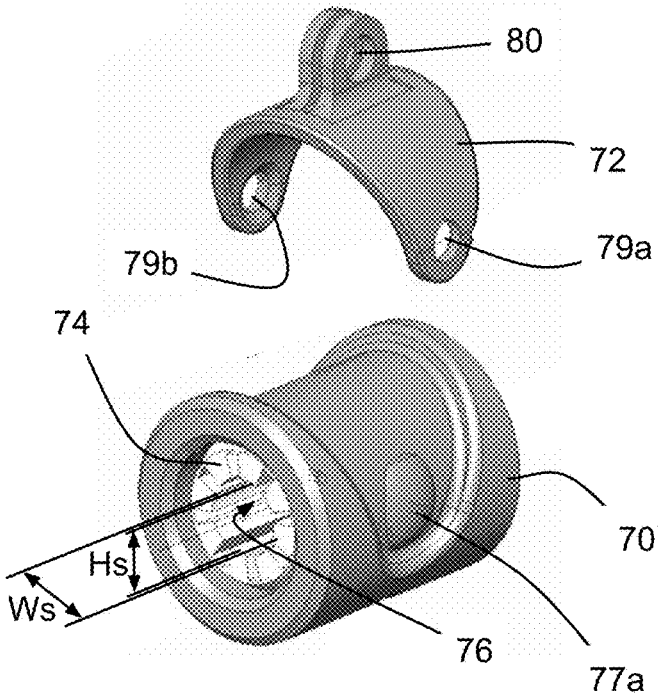

FIG. 5

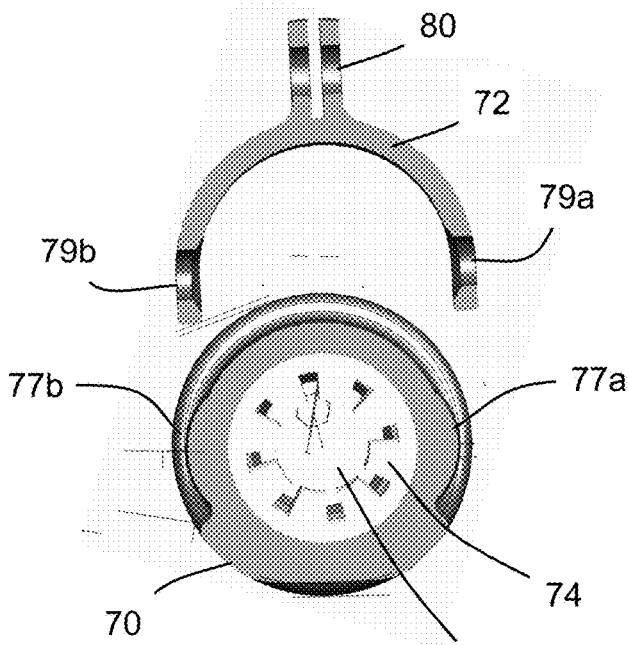

FIG. 5a

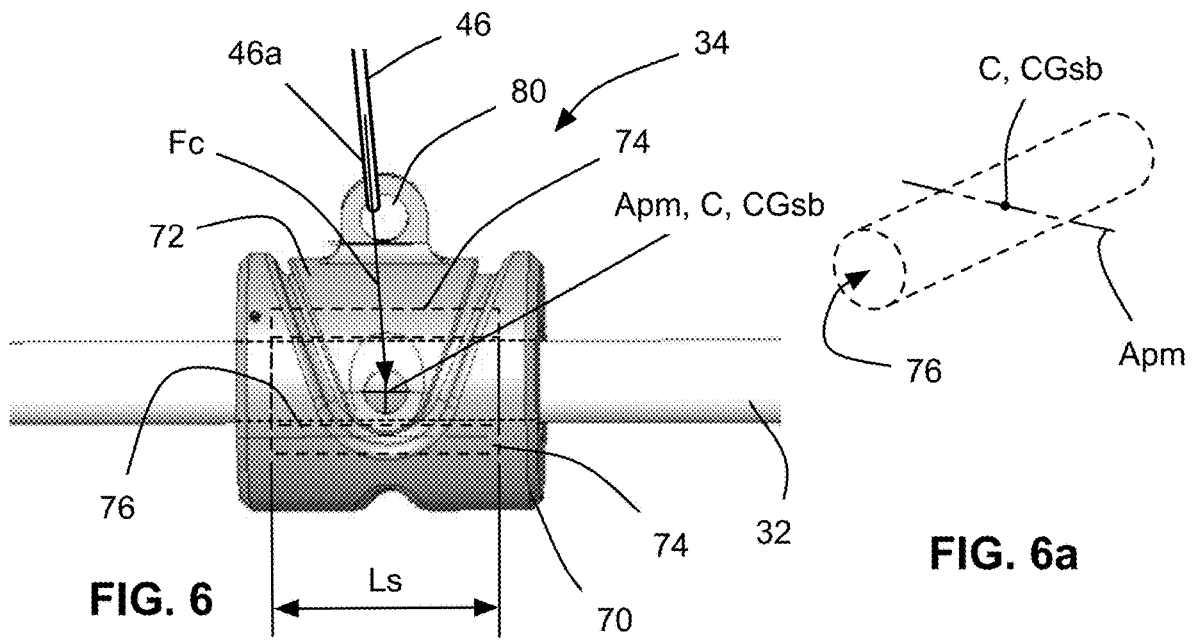

FIG. 6

FIG. 6a

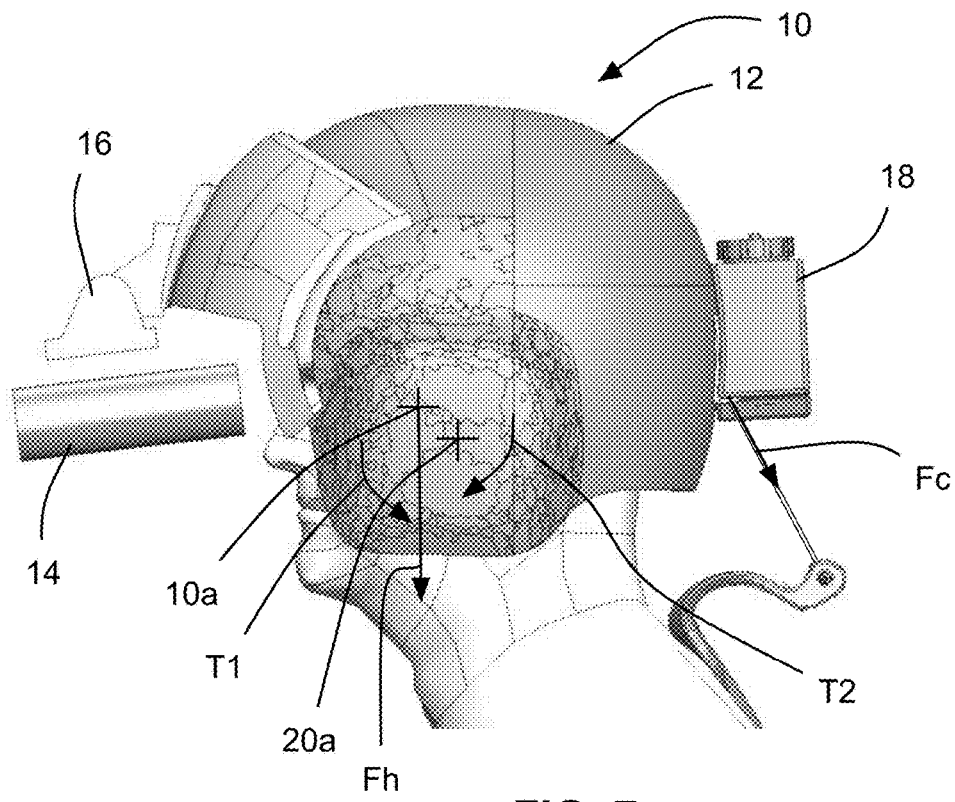

FIG. 7

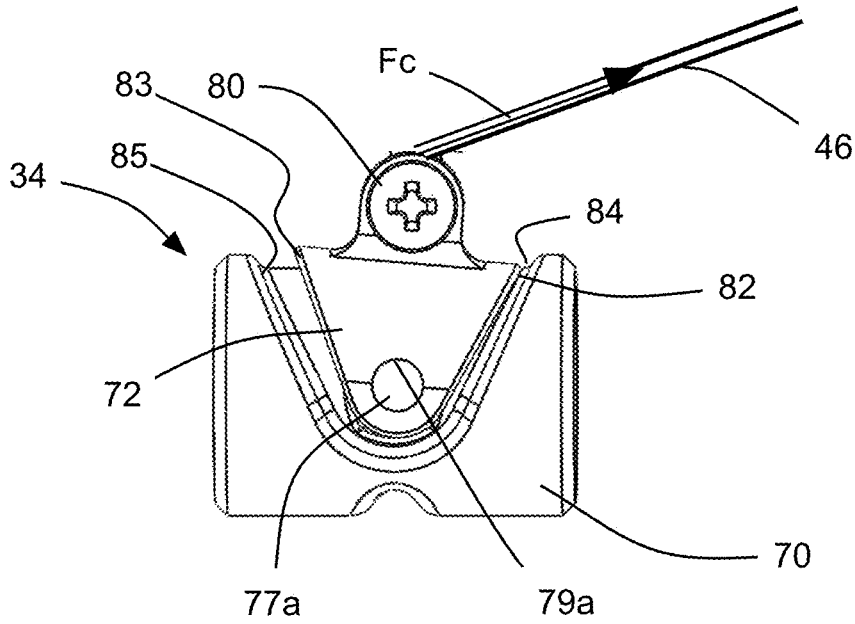

FIG. 8a

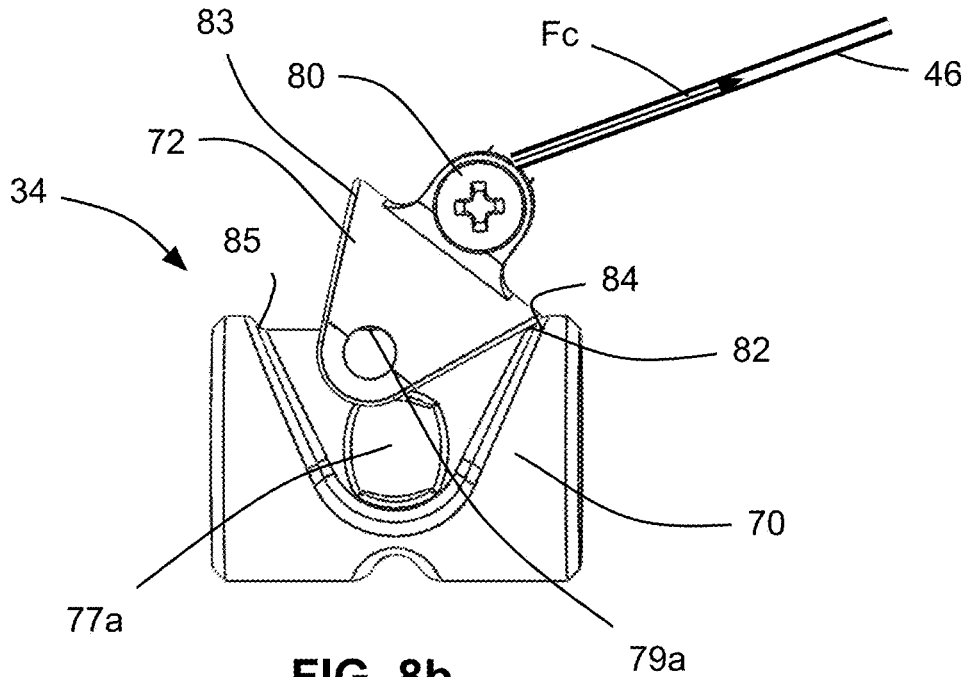
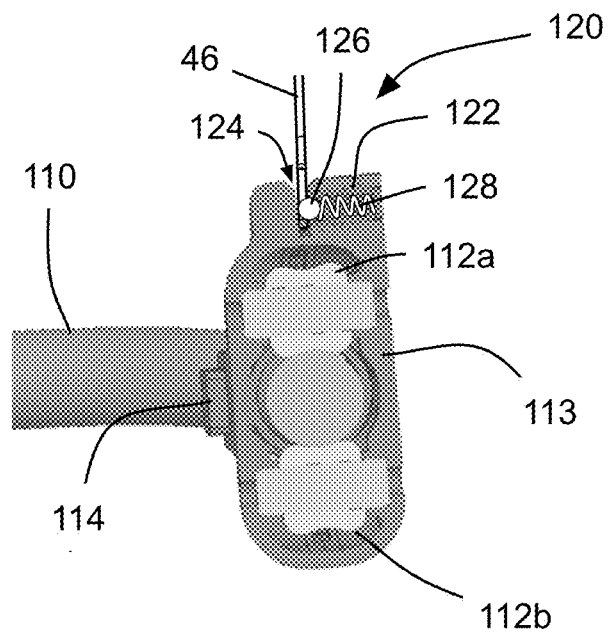
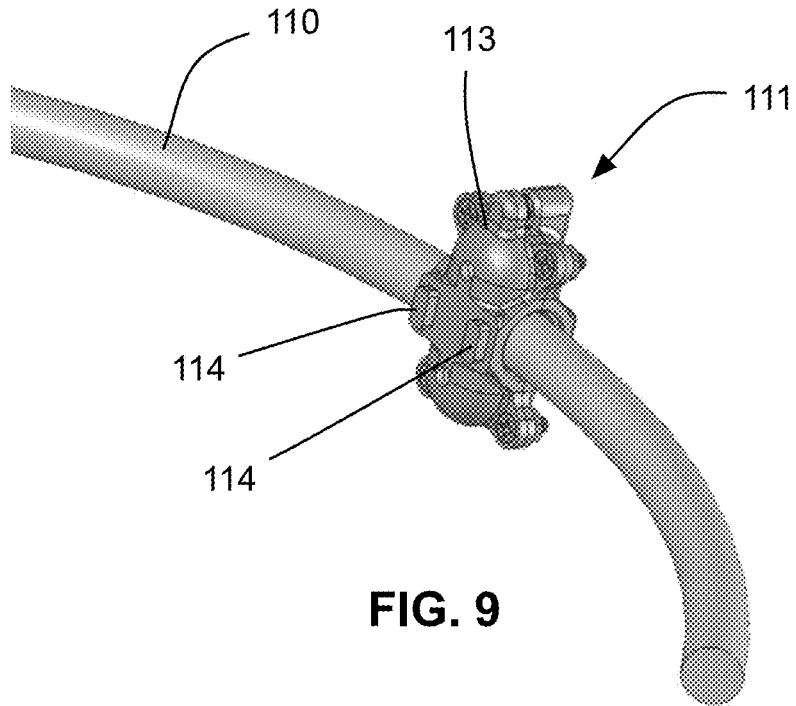

FIG. 8b



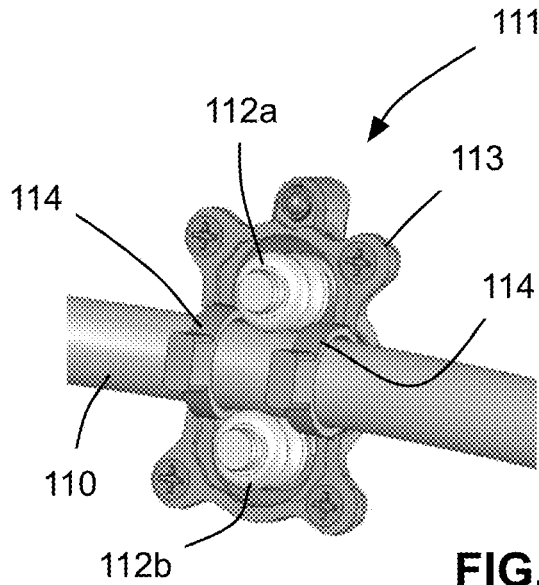

FIG. 10b

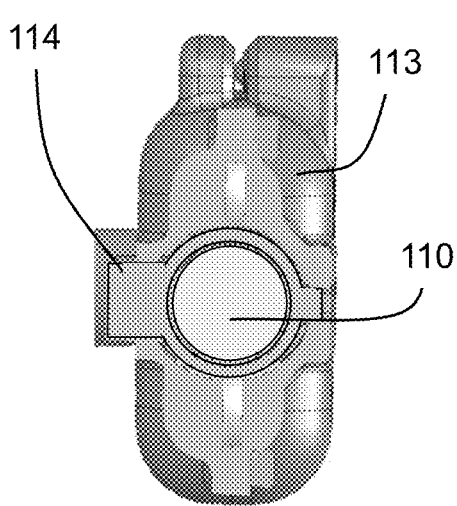

FIG. 10c

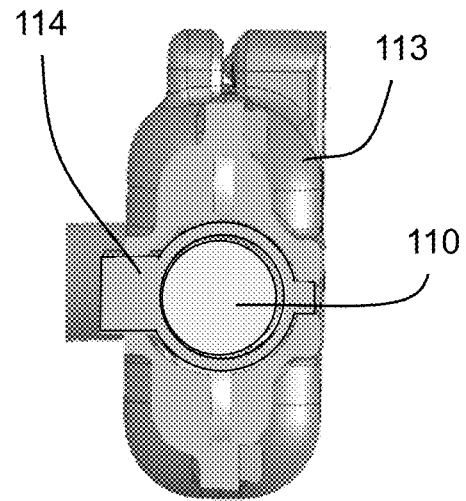

FIG. 10d

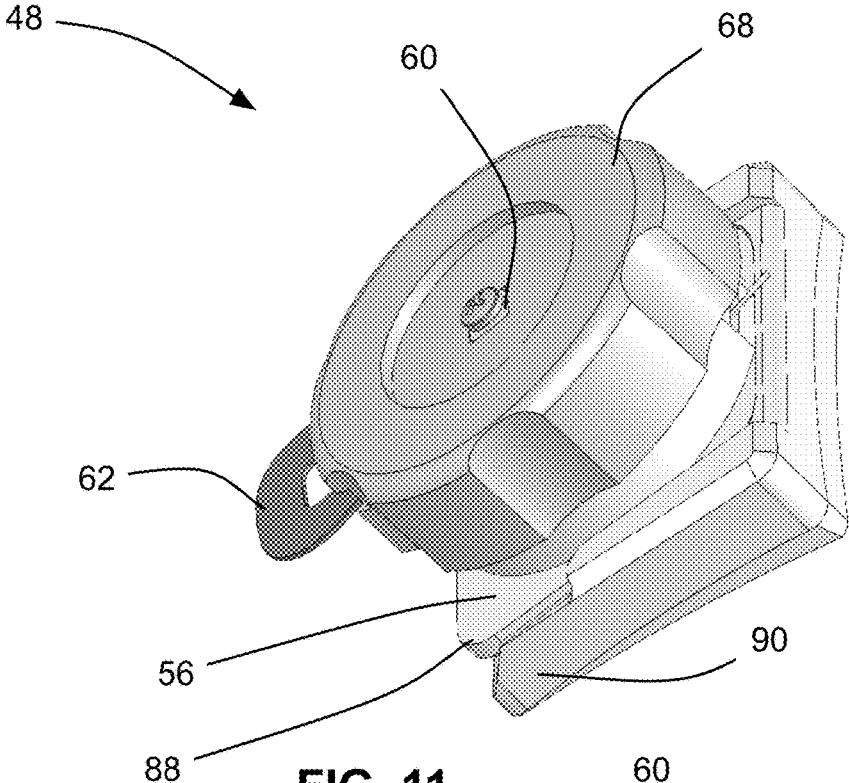

FIG. 11

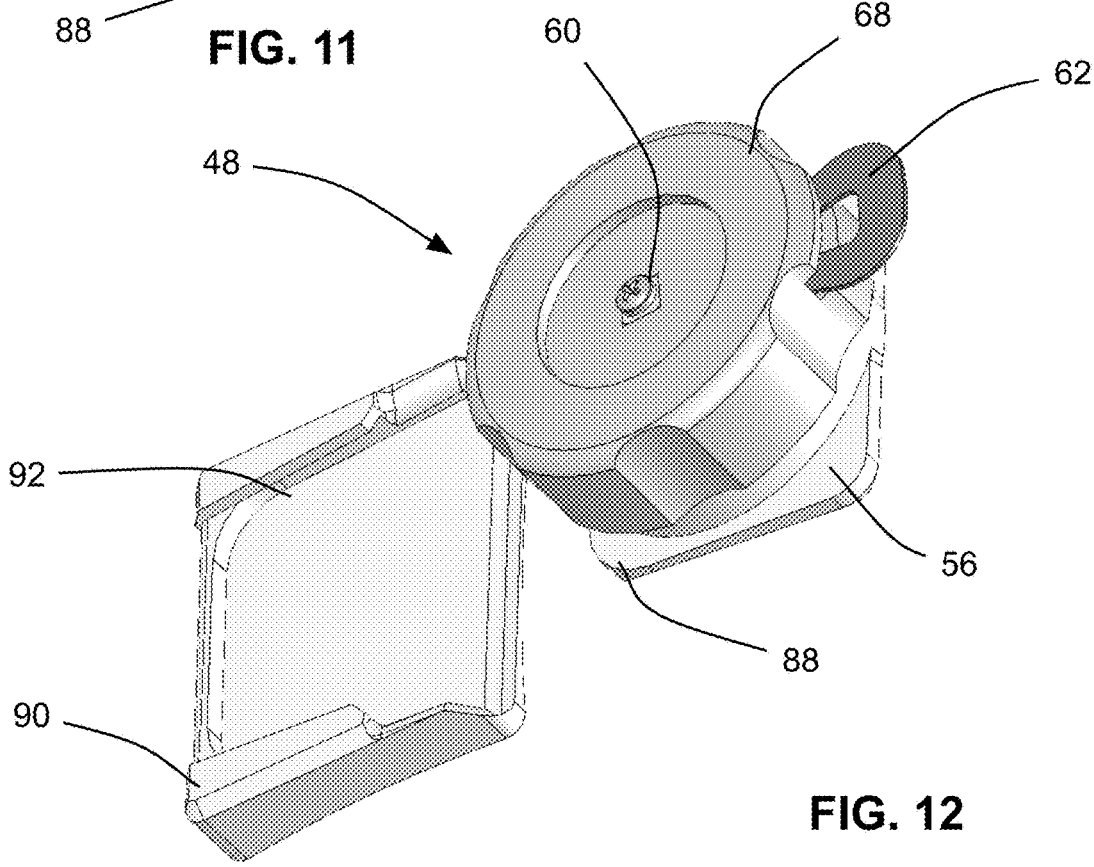
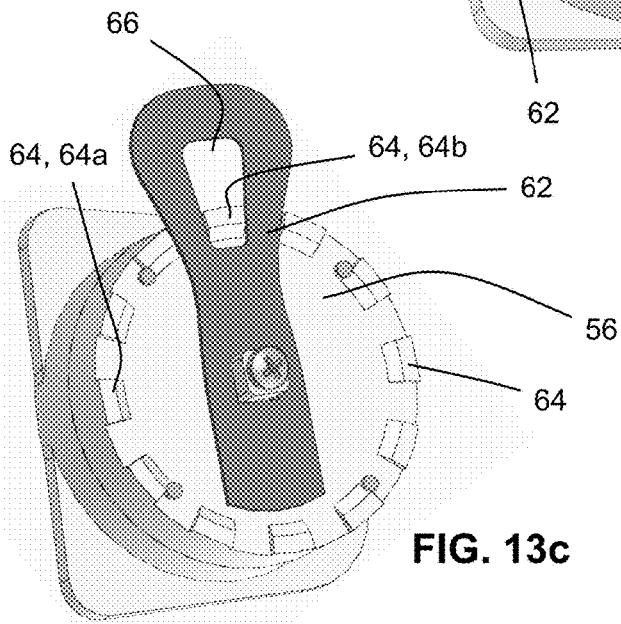
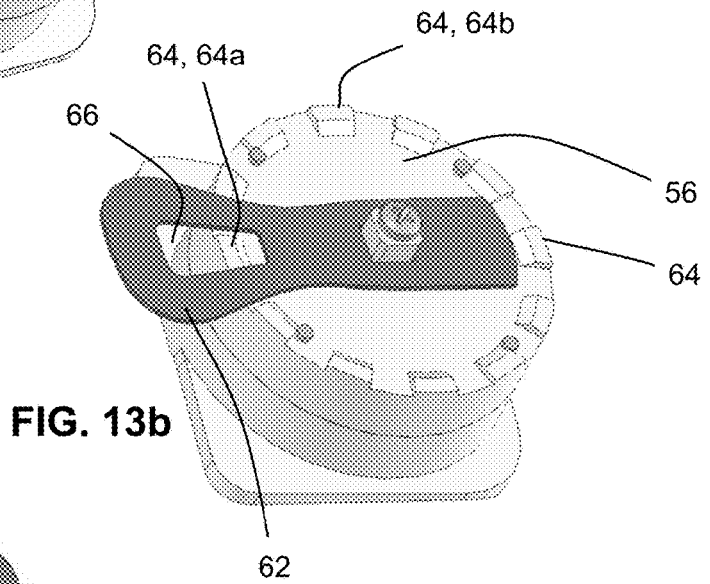
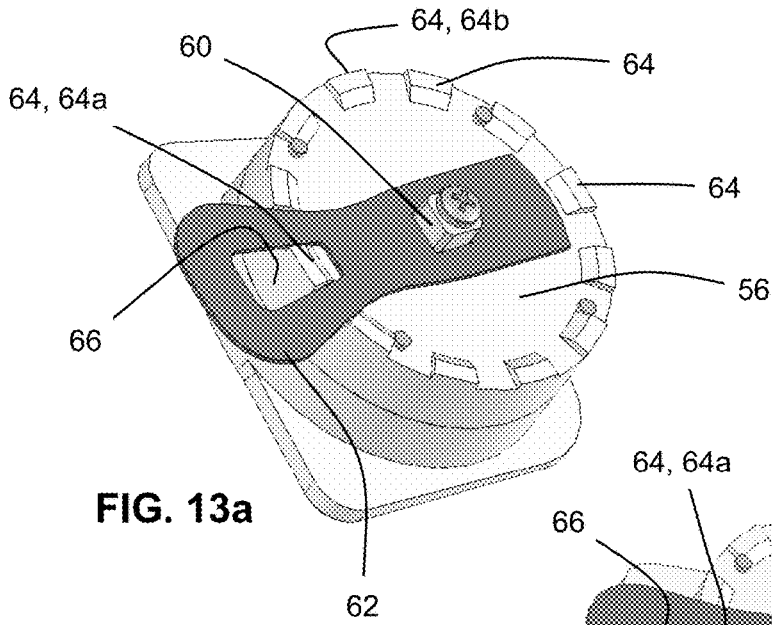

FIG. 12



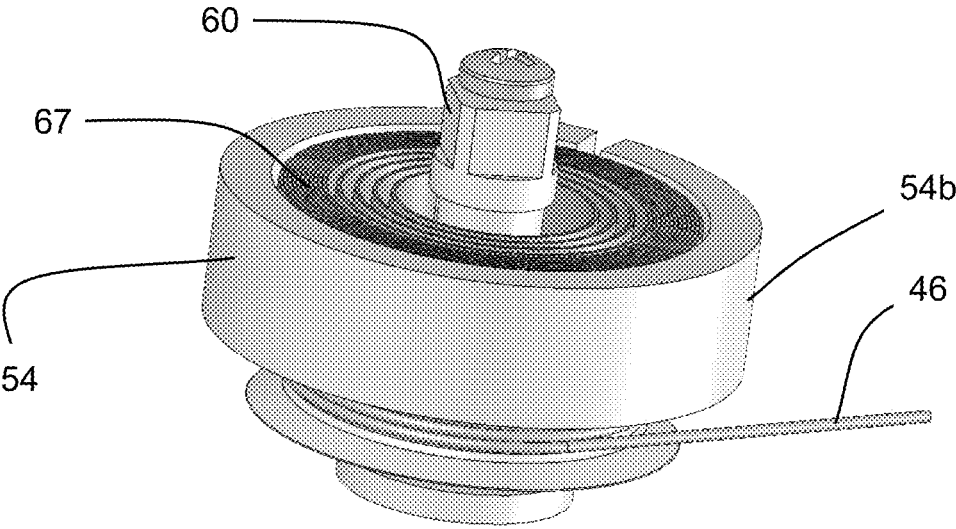

FIG. 14a

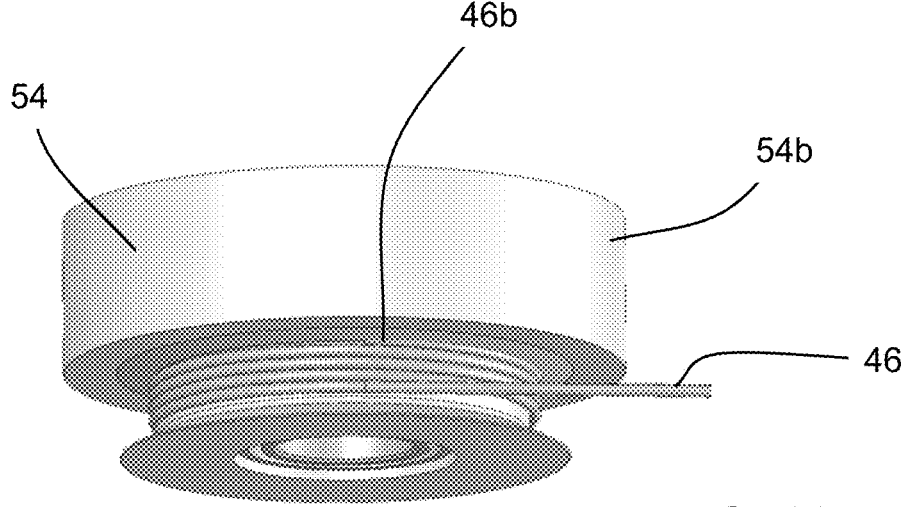

FIG. 14b

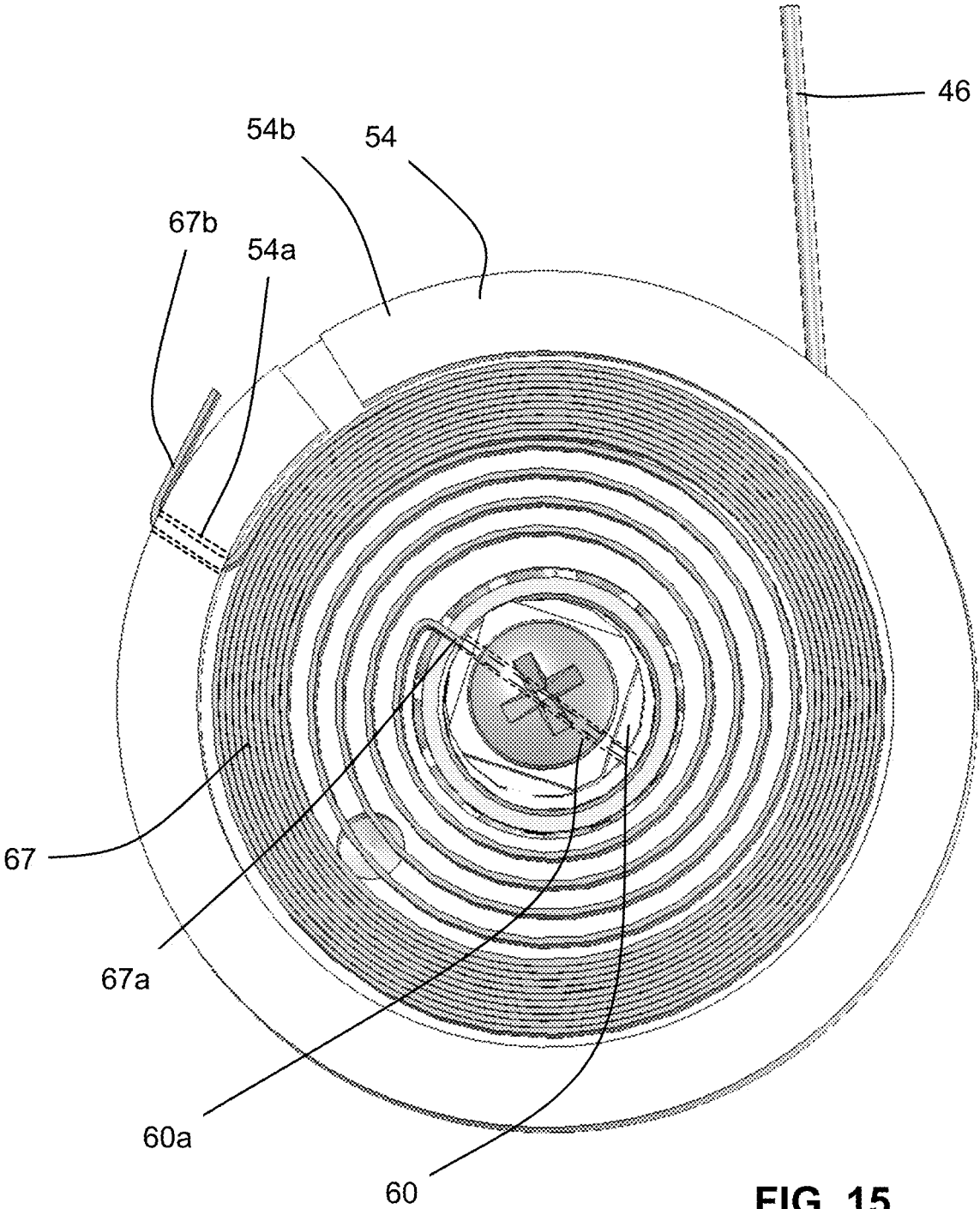

FIG. 15

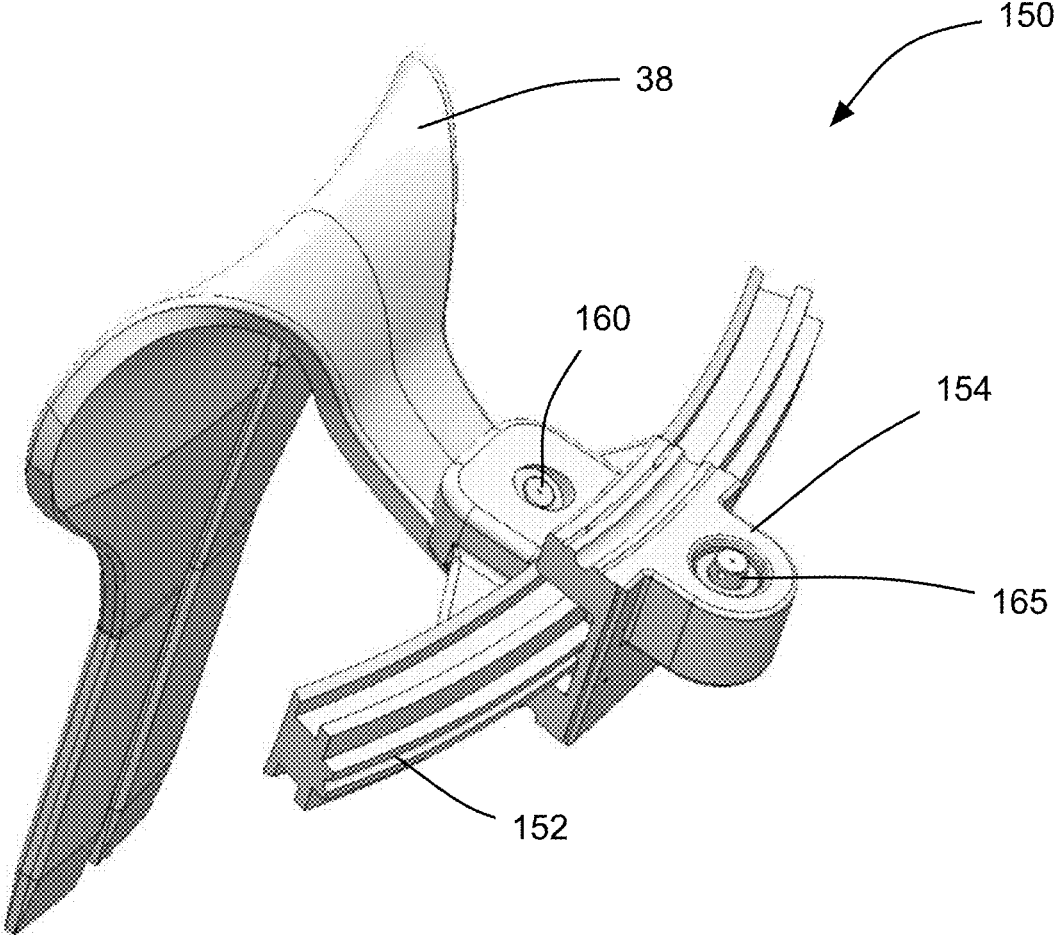

FIG. 16

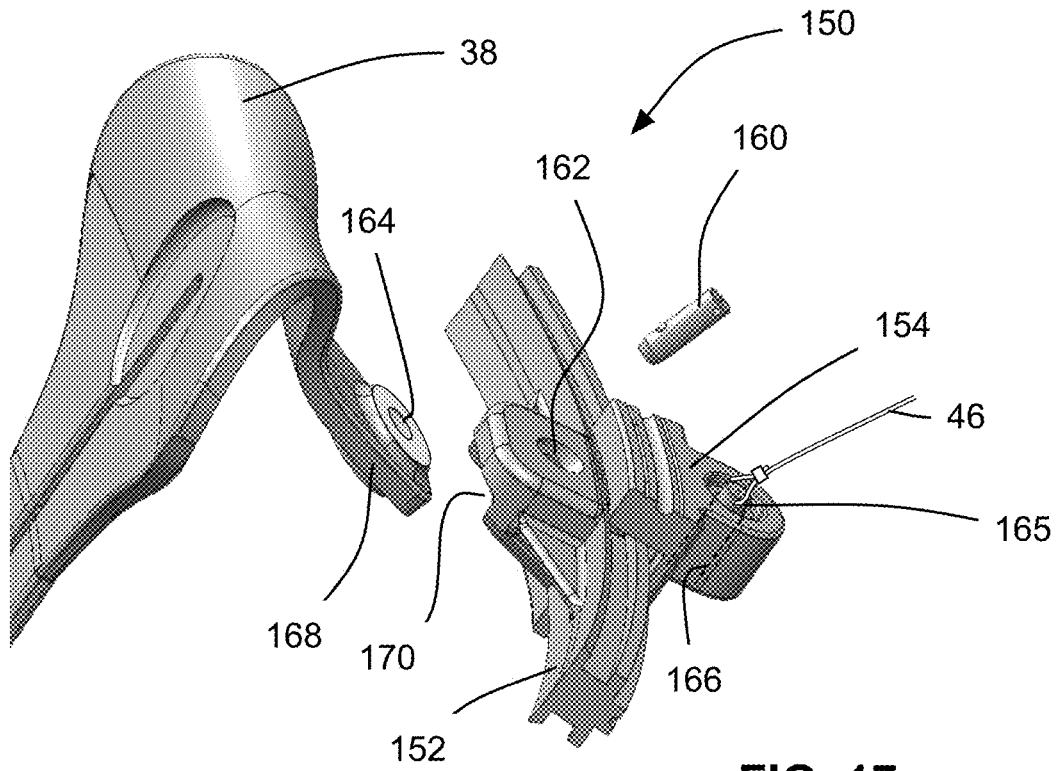

FIG. 17

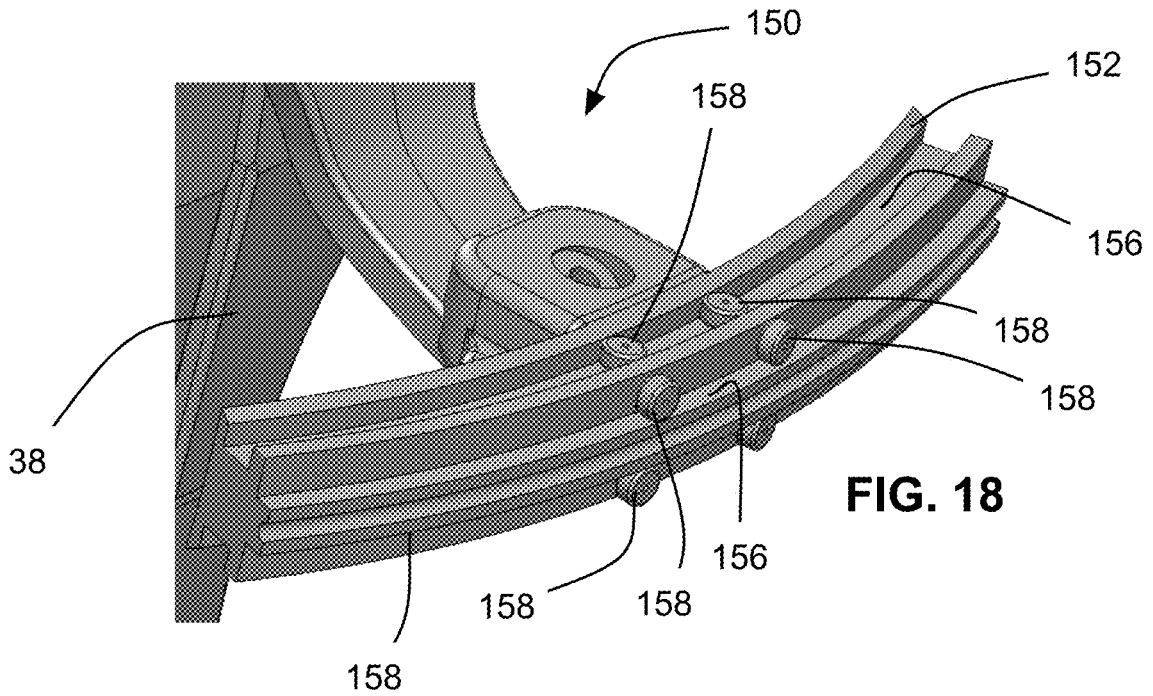

FIG. 18

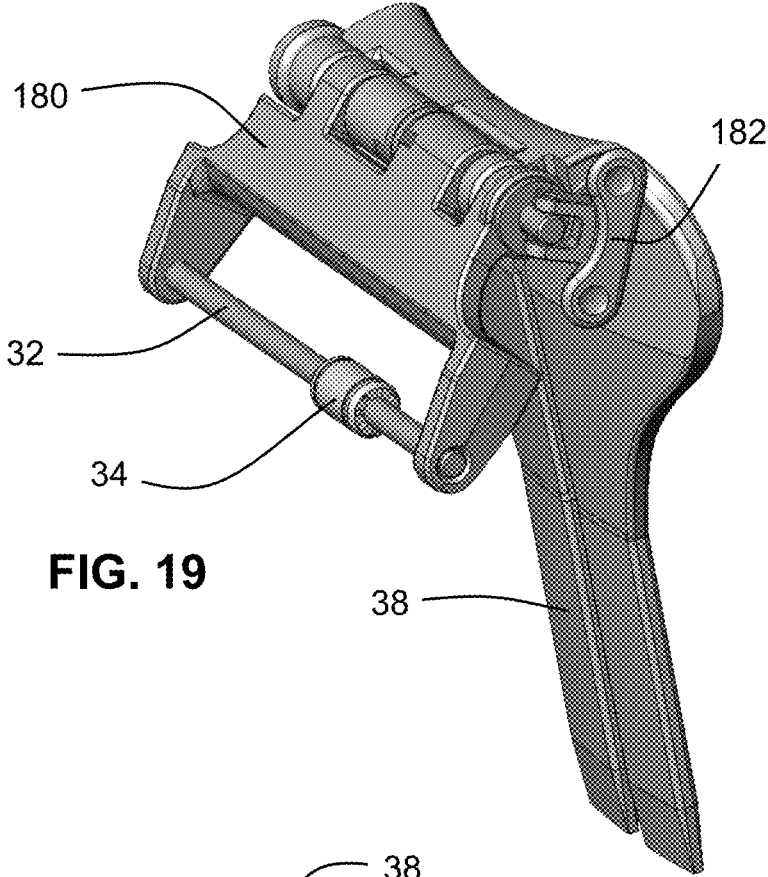

FIG. 19

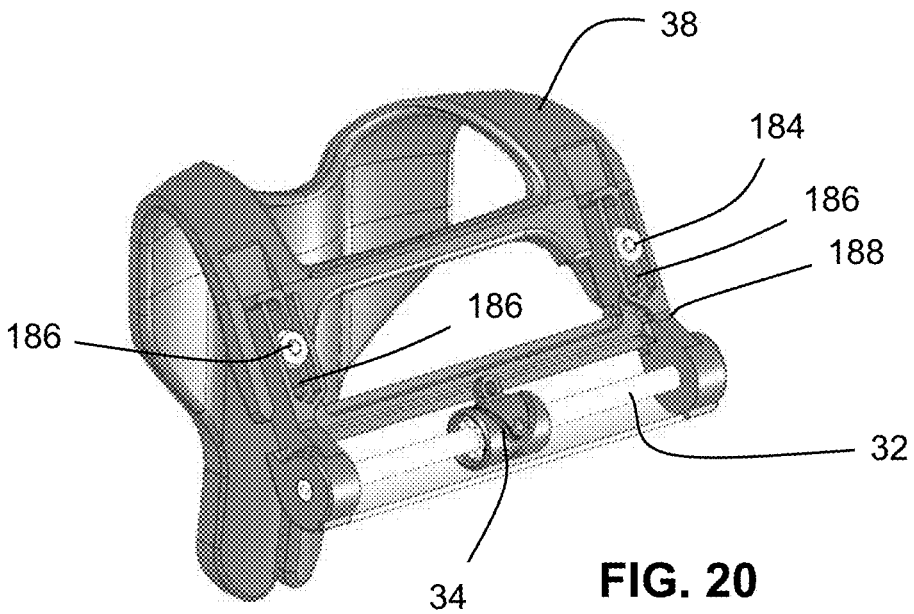

FIG. 20

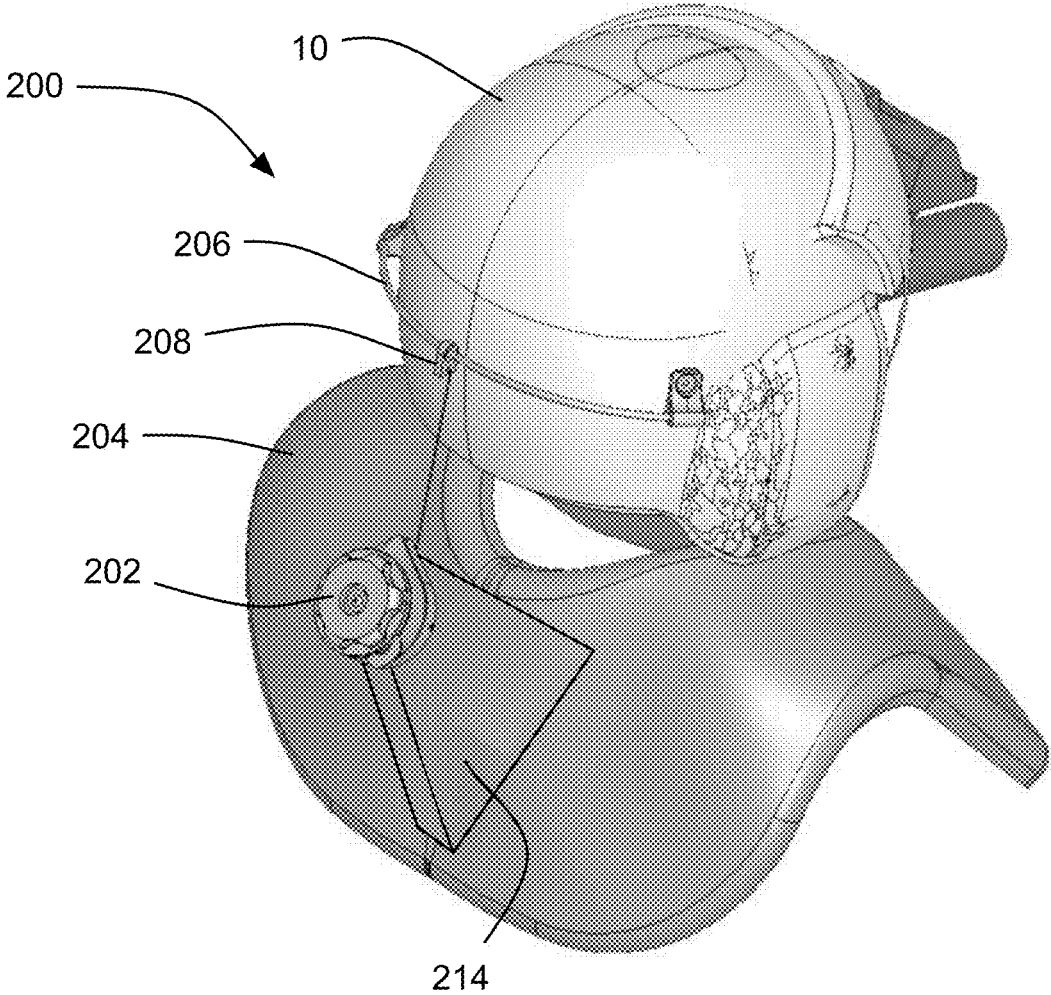

FIG. 21

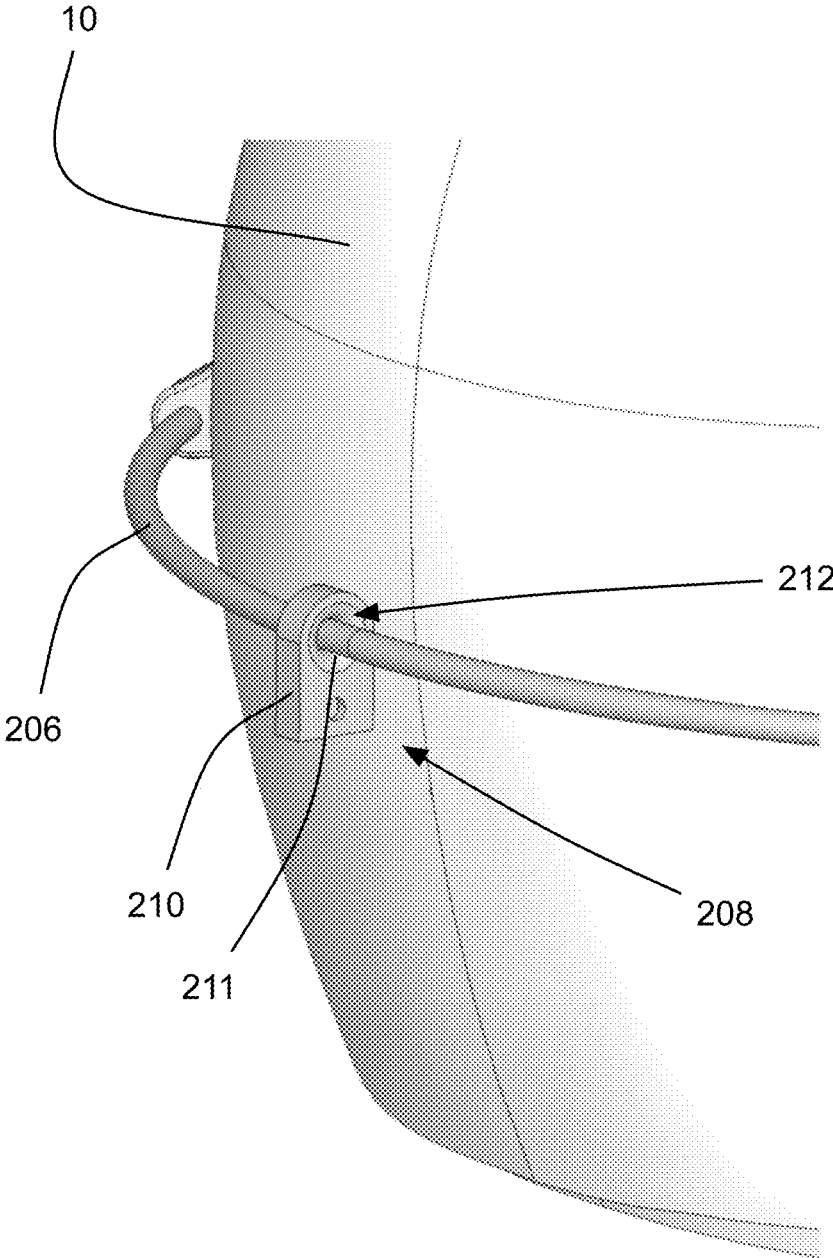
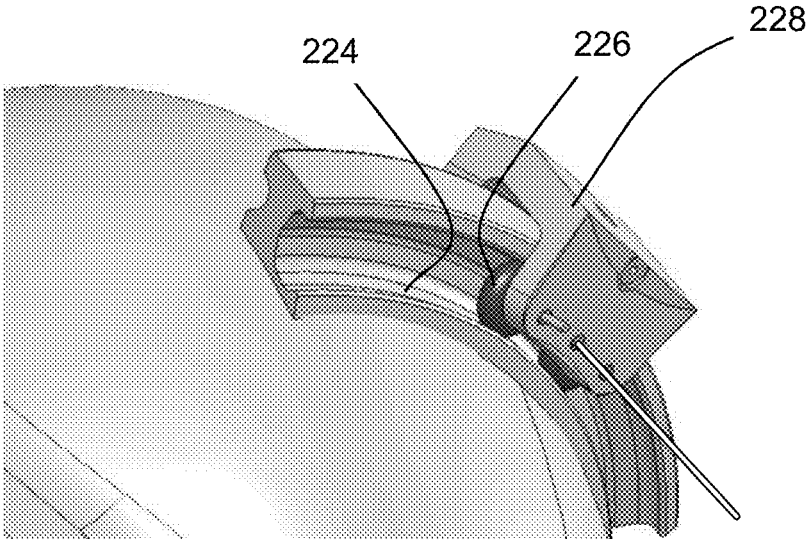
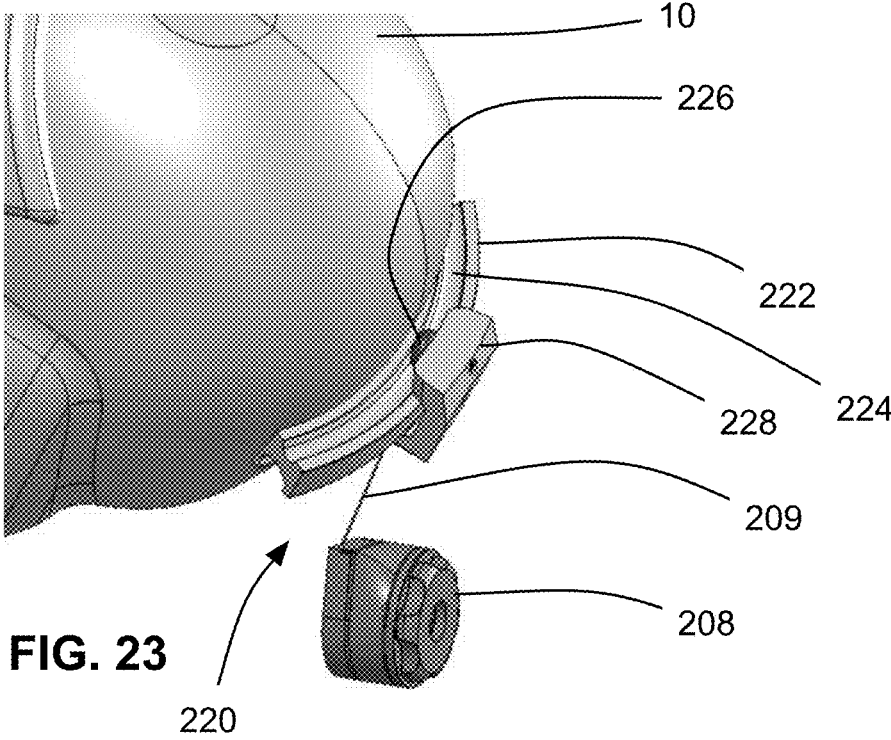
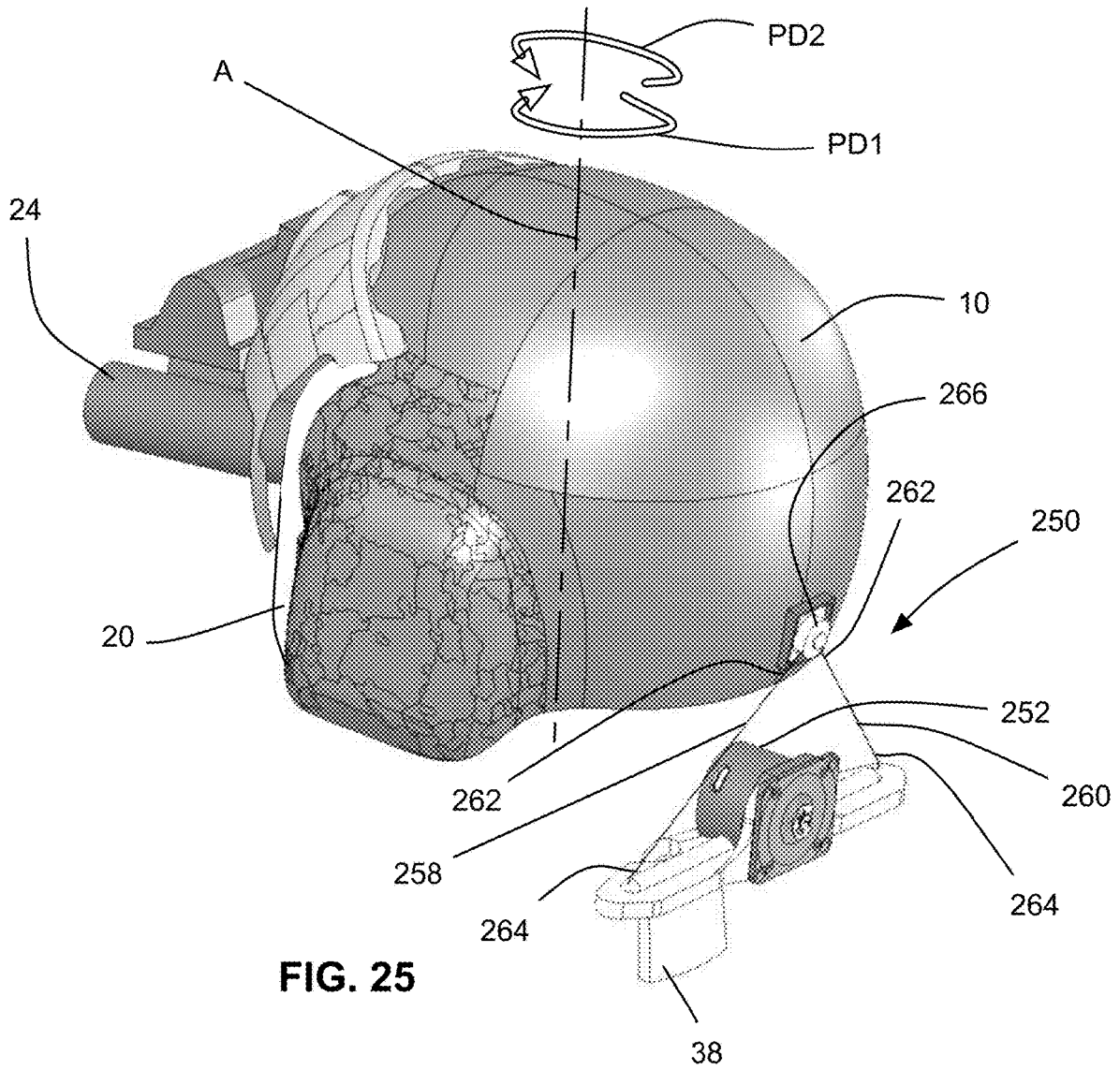

FIG. 22





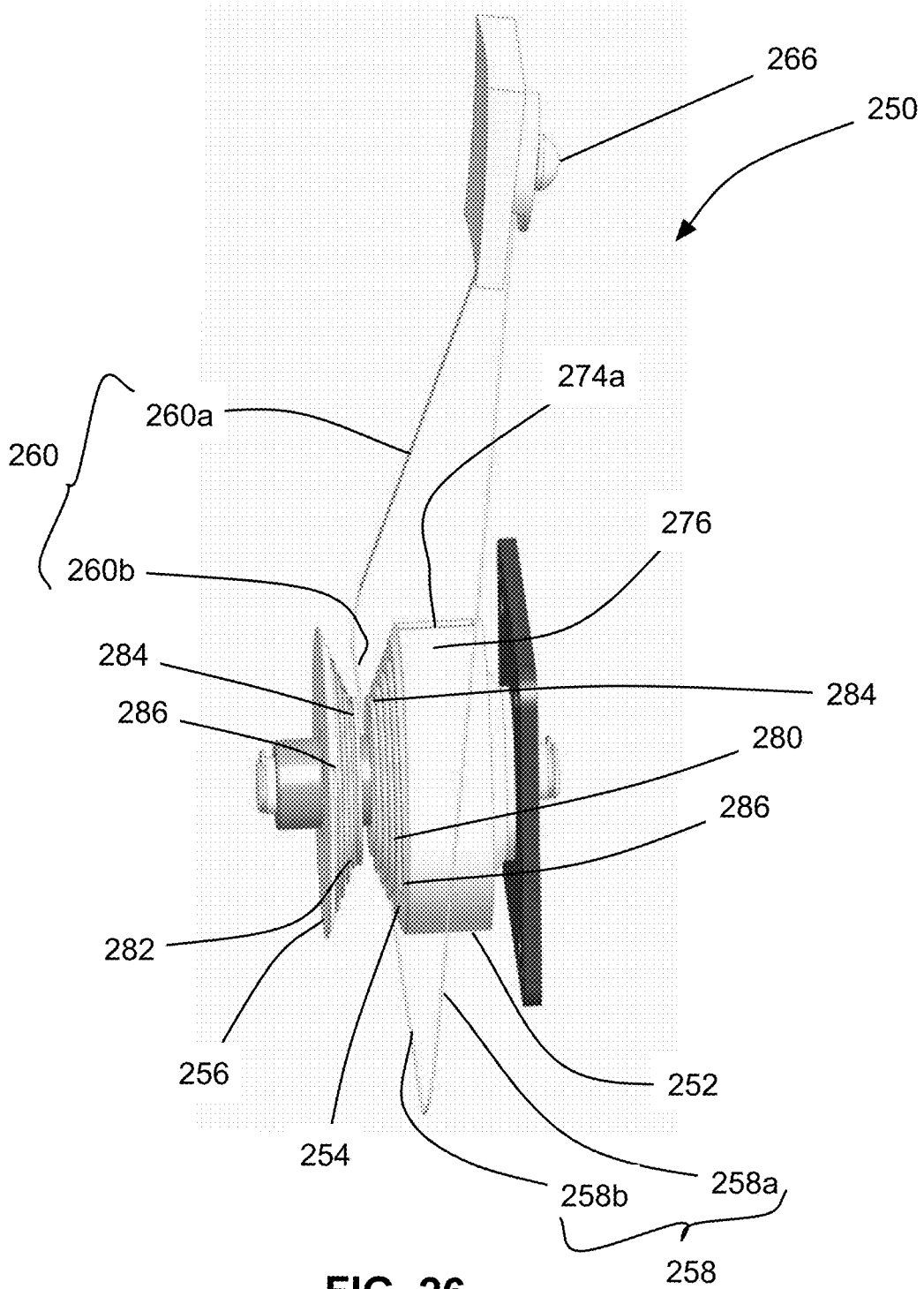
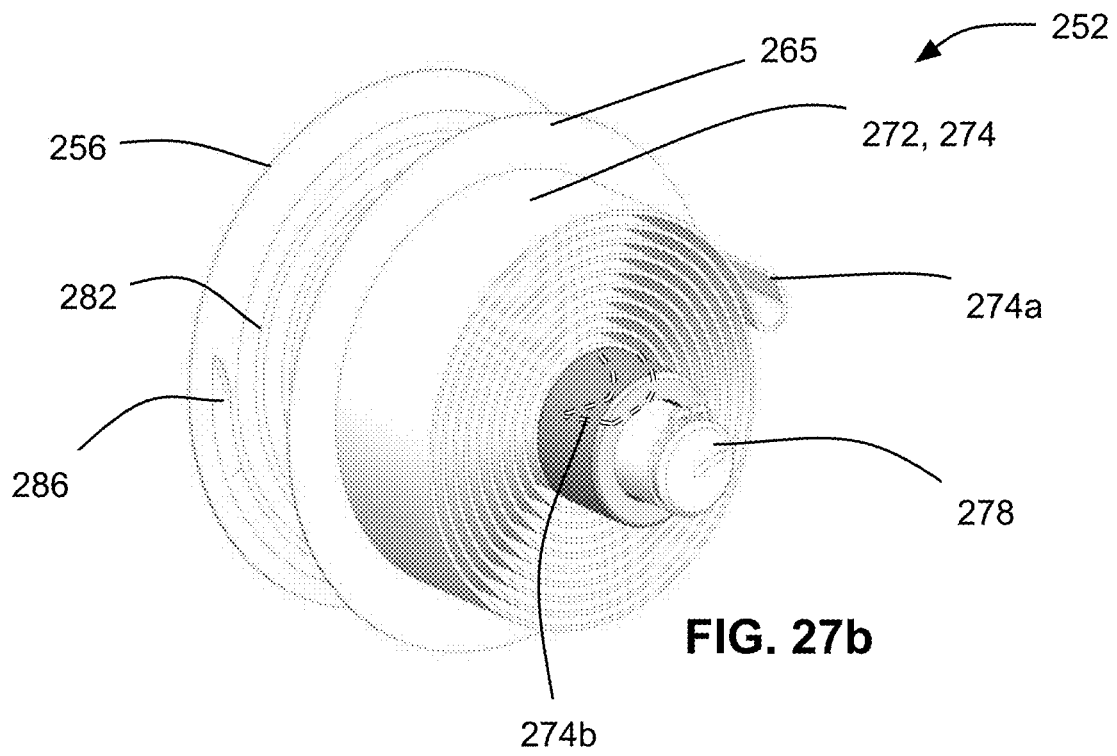
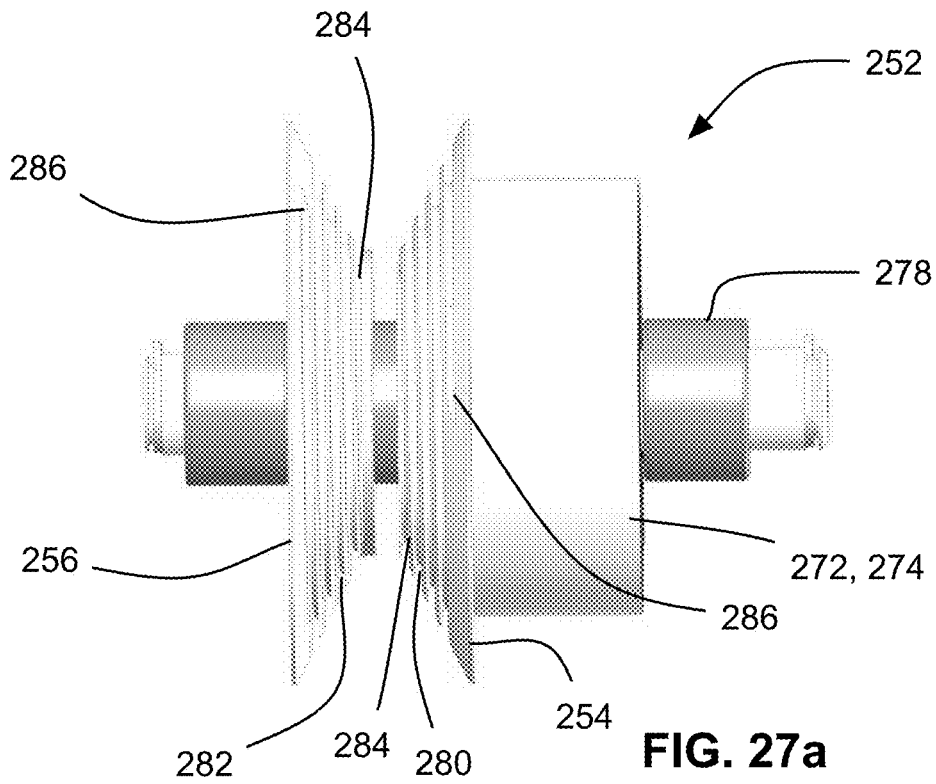

FIG. 26



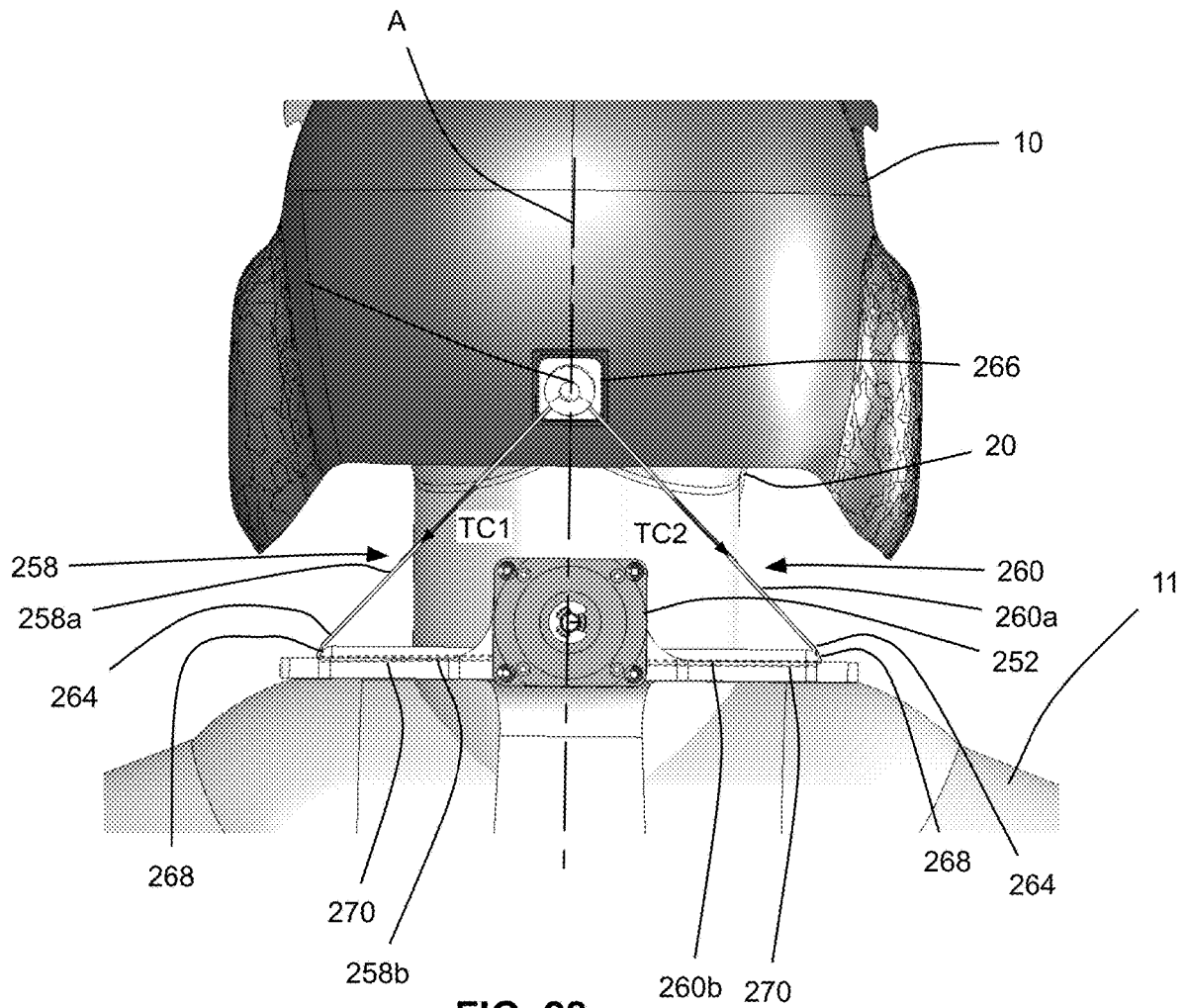

FIG. 28

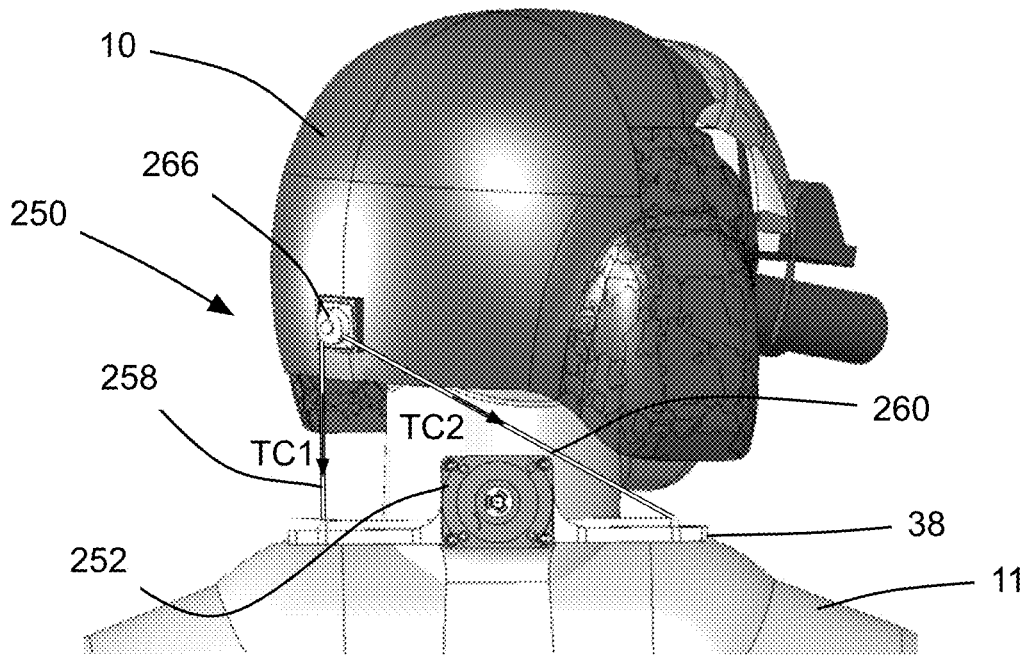

FIG. 29

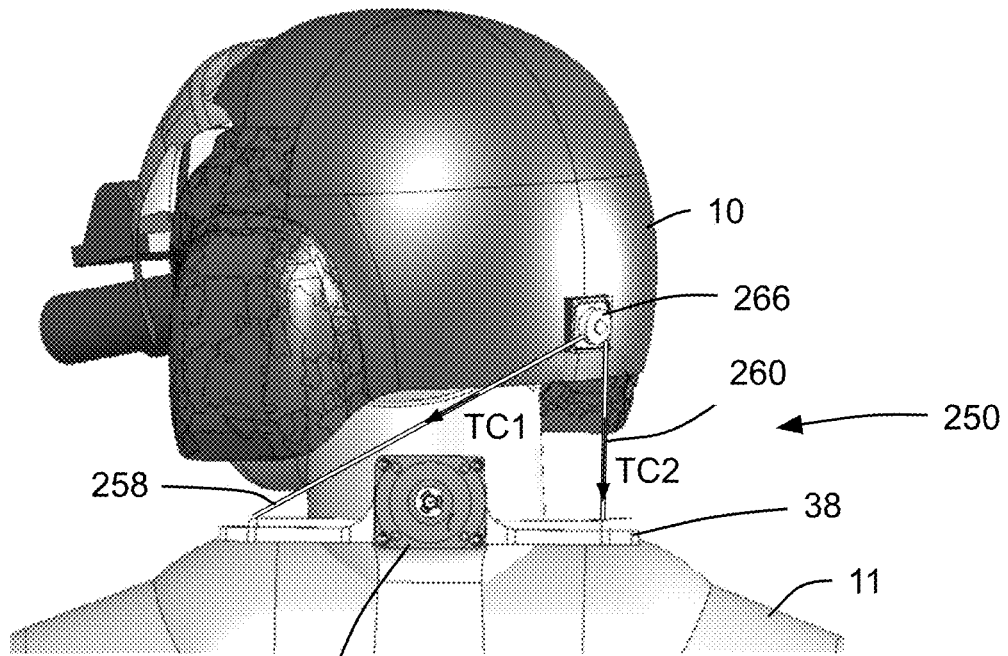

FIG. 30

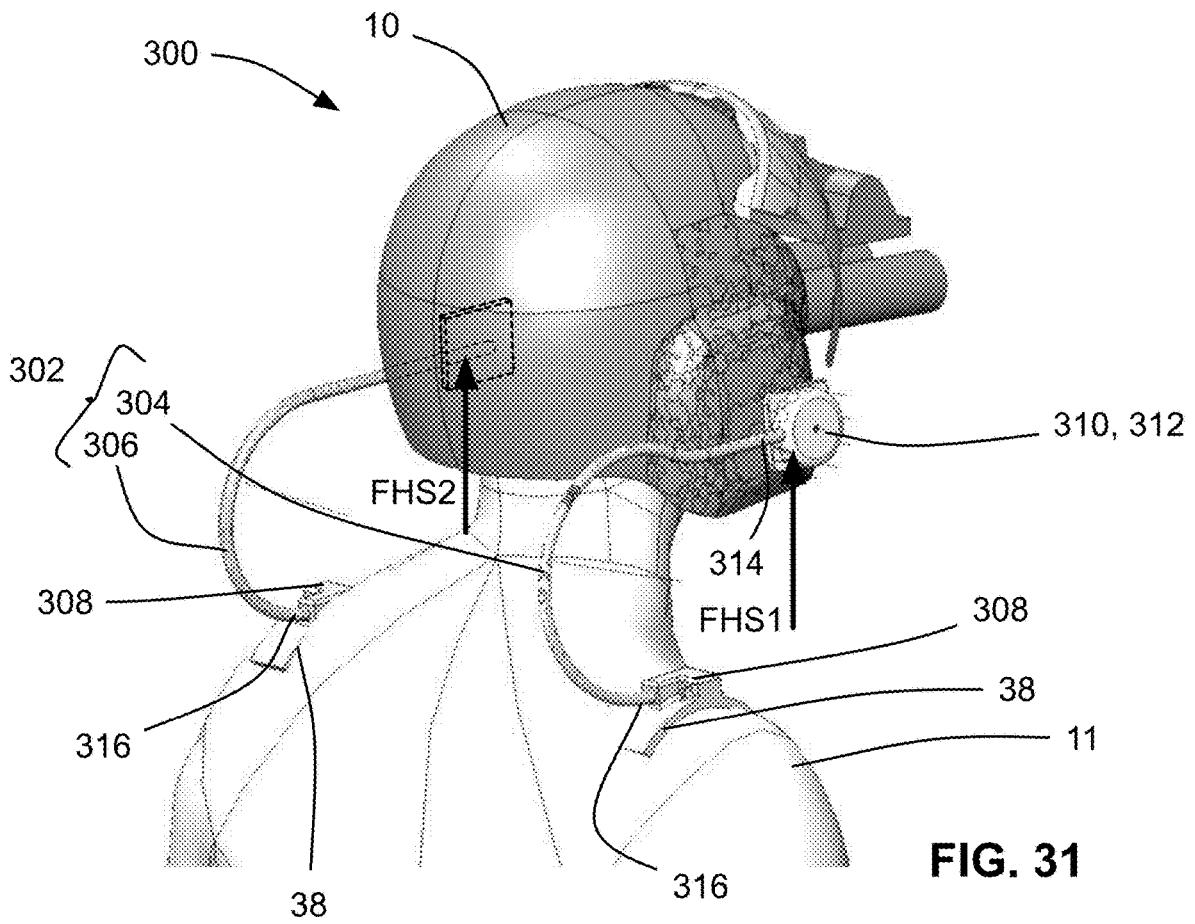

FIG. 31

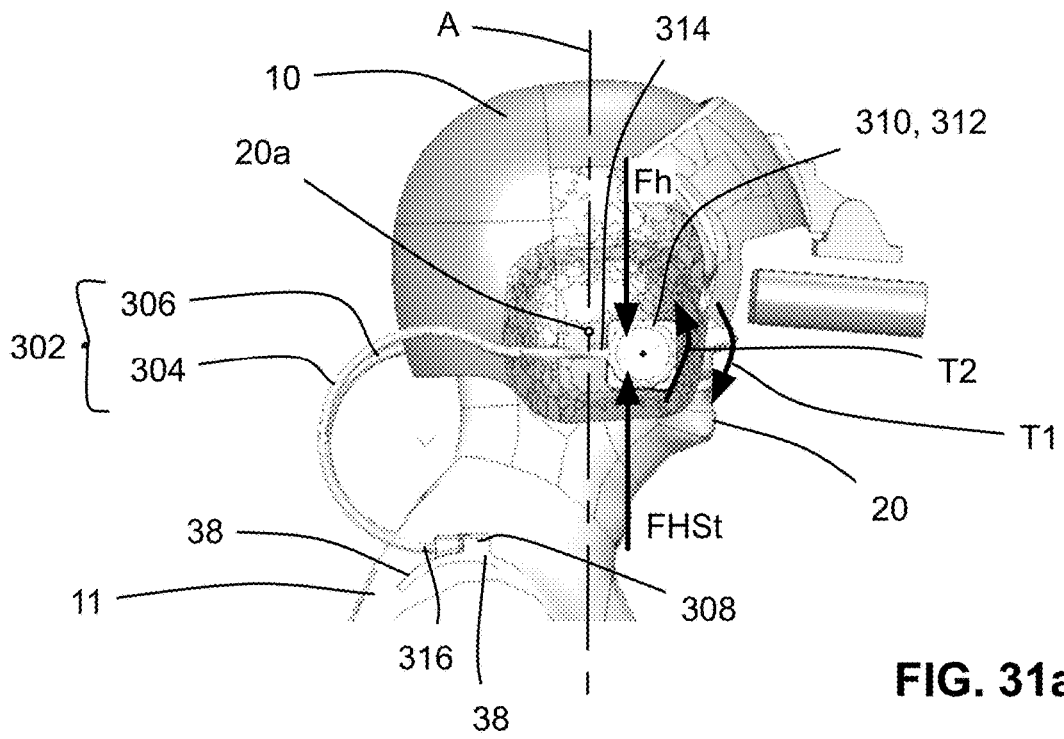

FIG. 31a

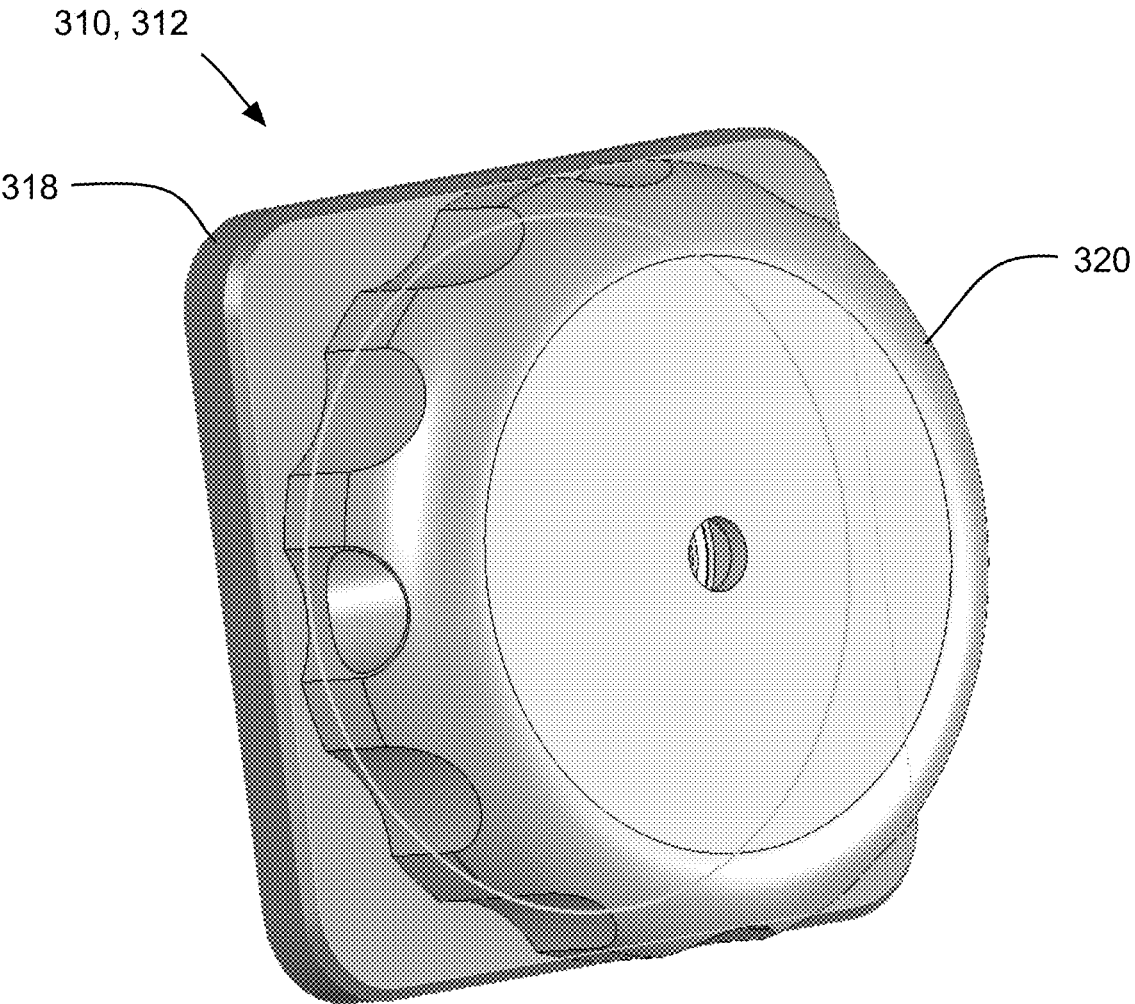

FIG. 32

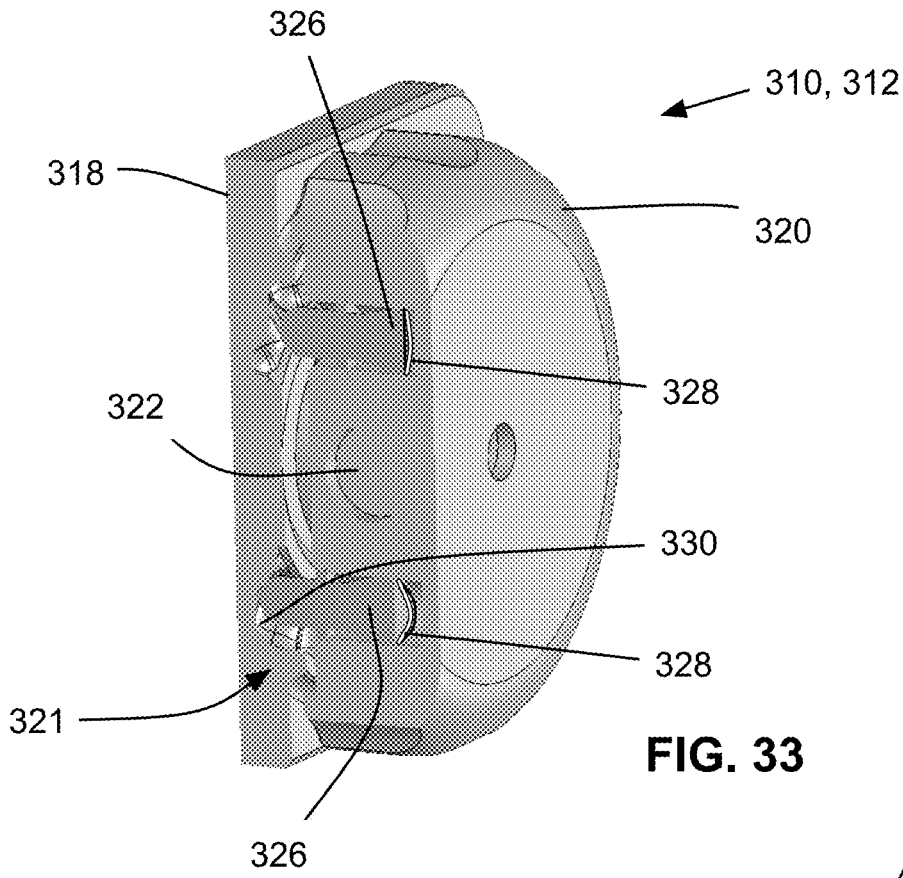

FIG. 33

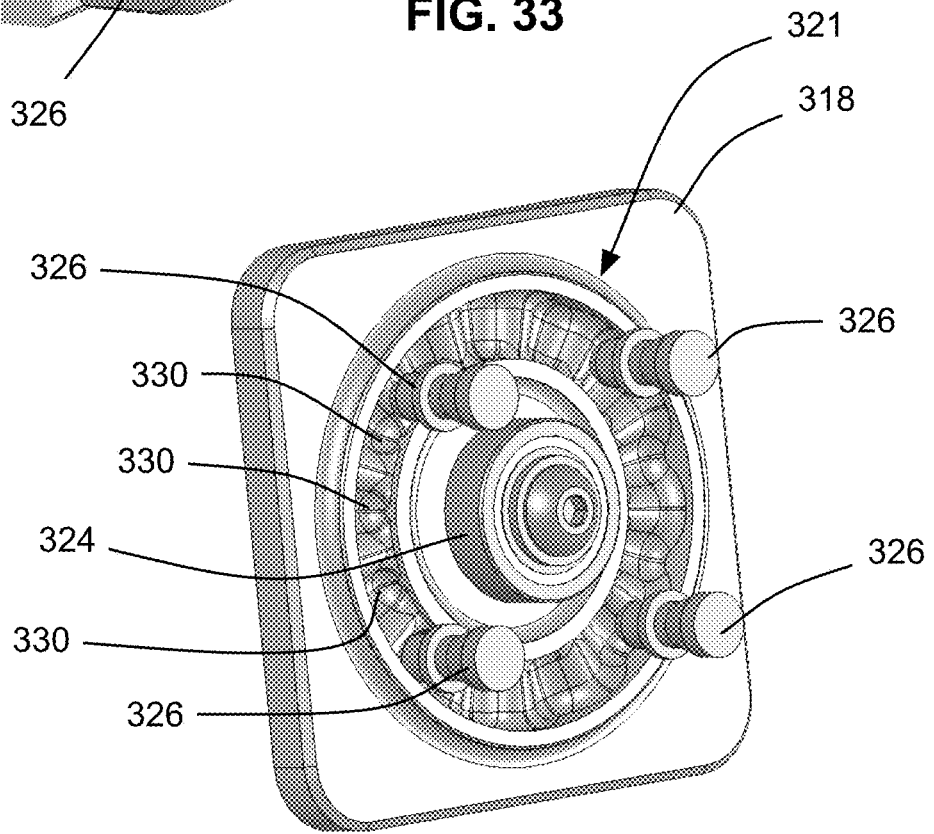

FIG. 34

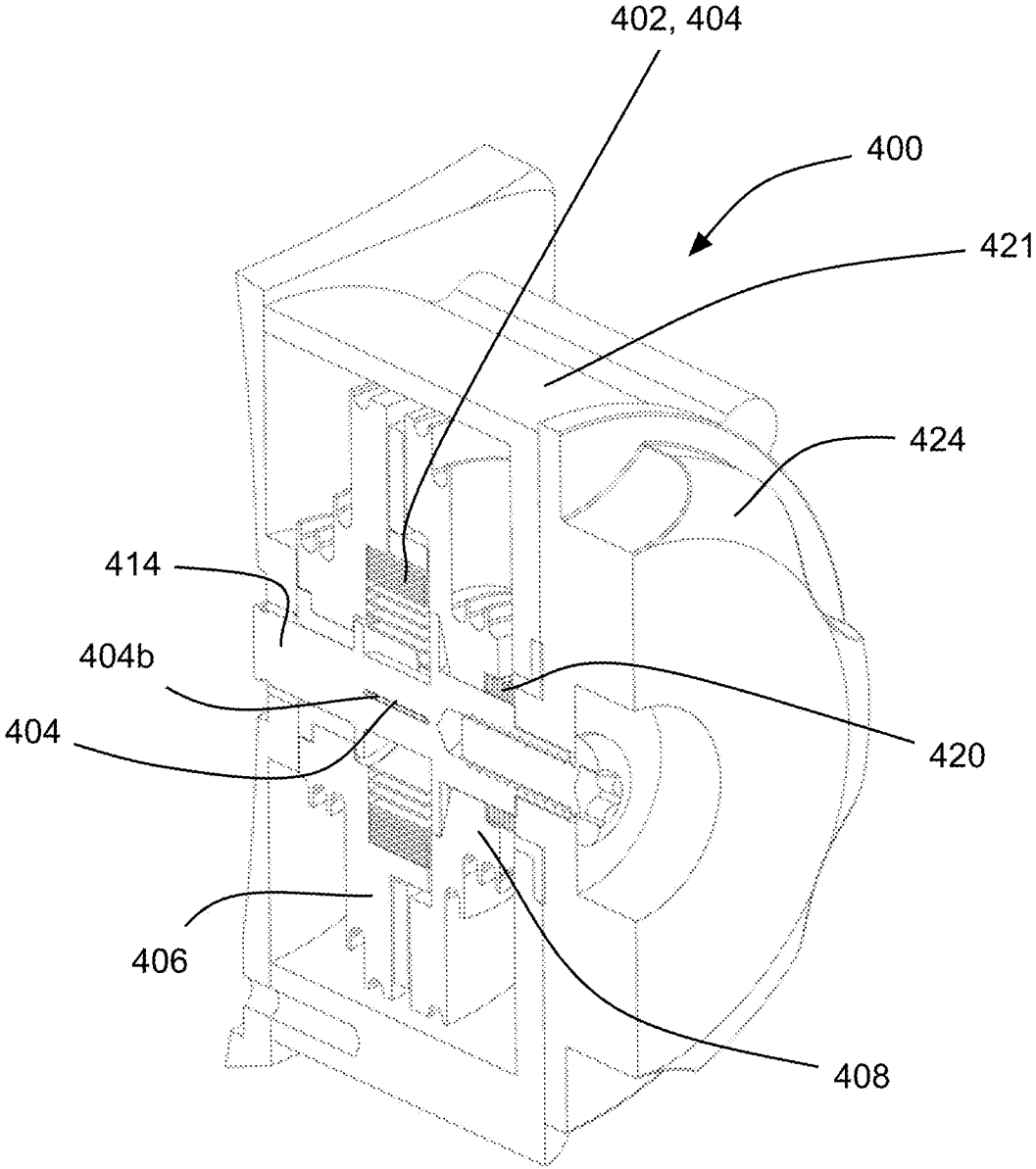

FIG. 35

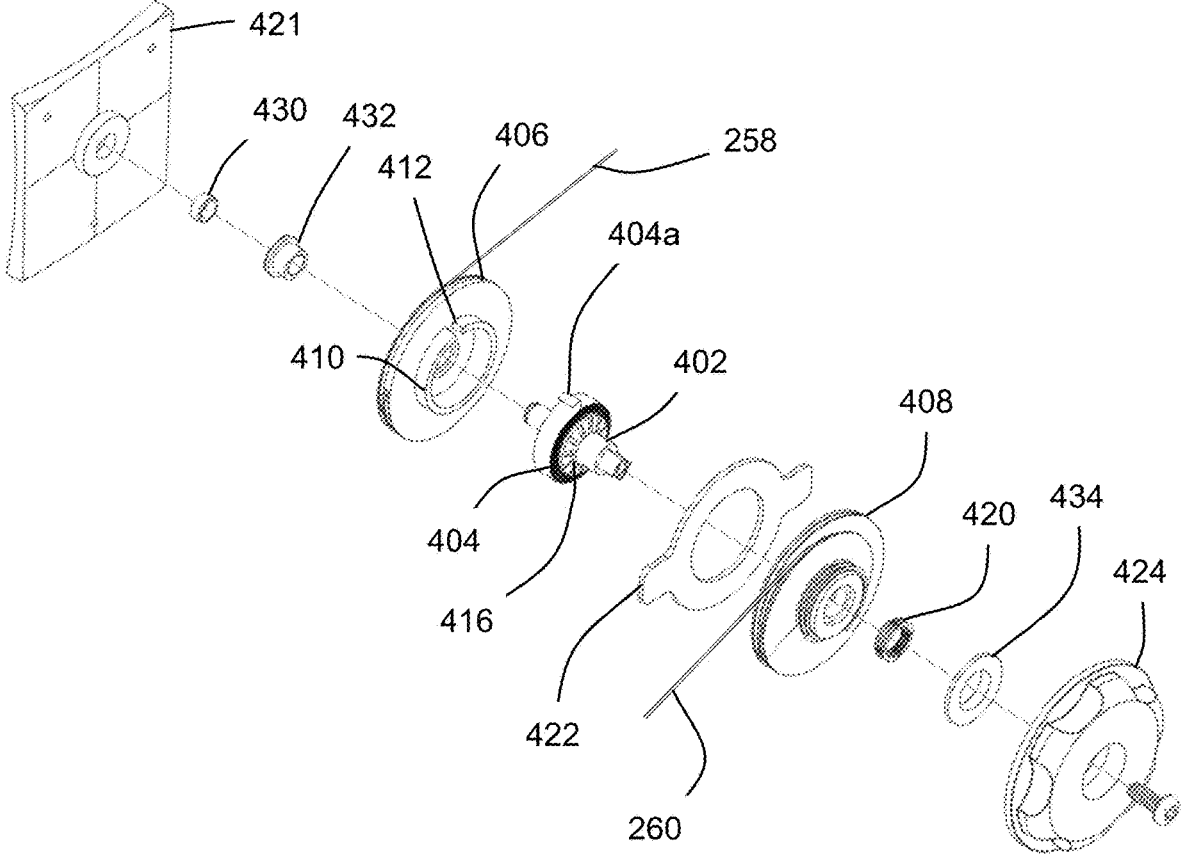

FIG. 36

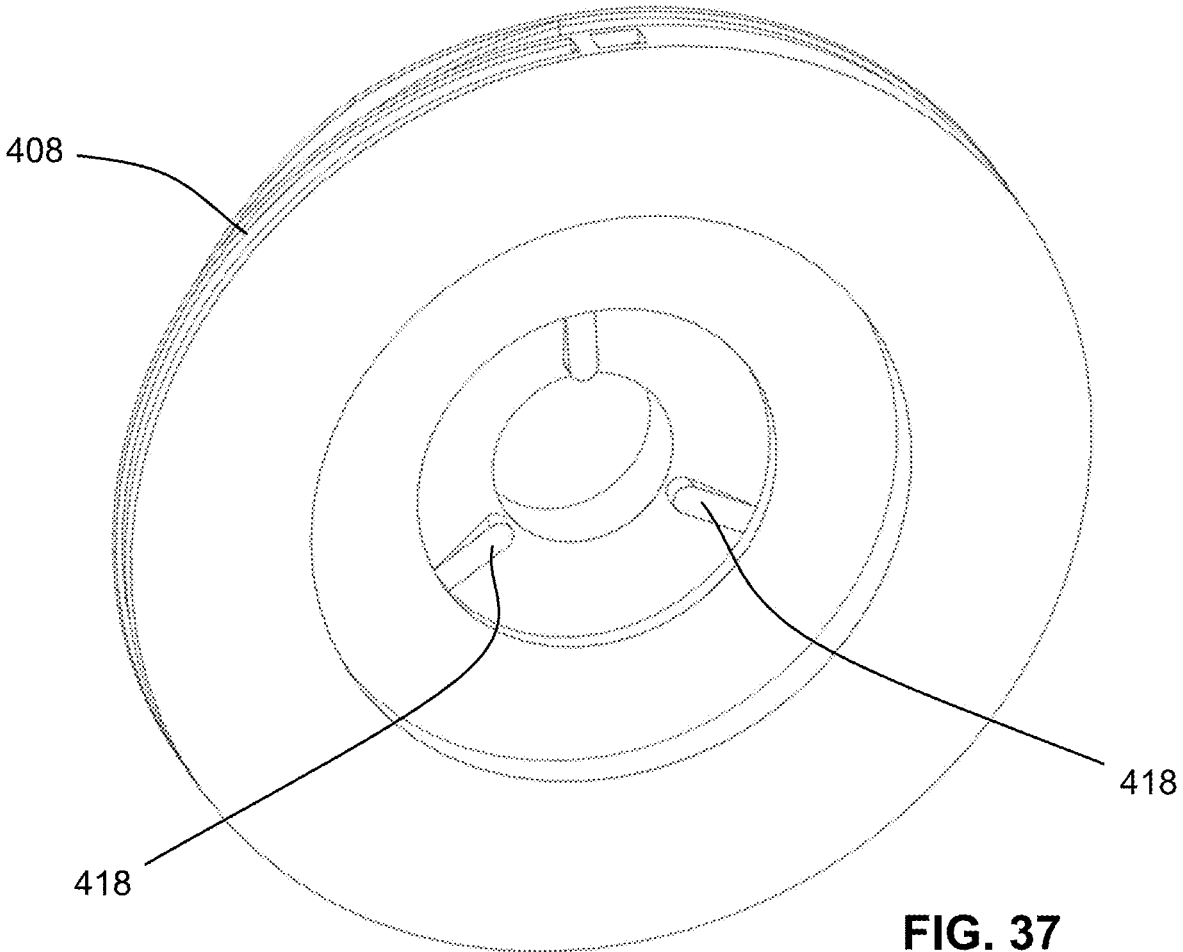

FIG. 37

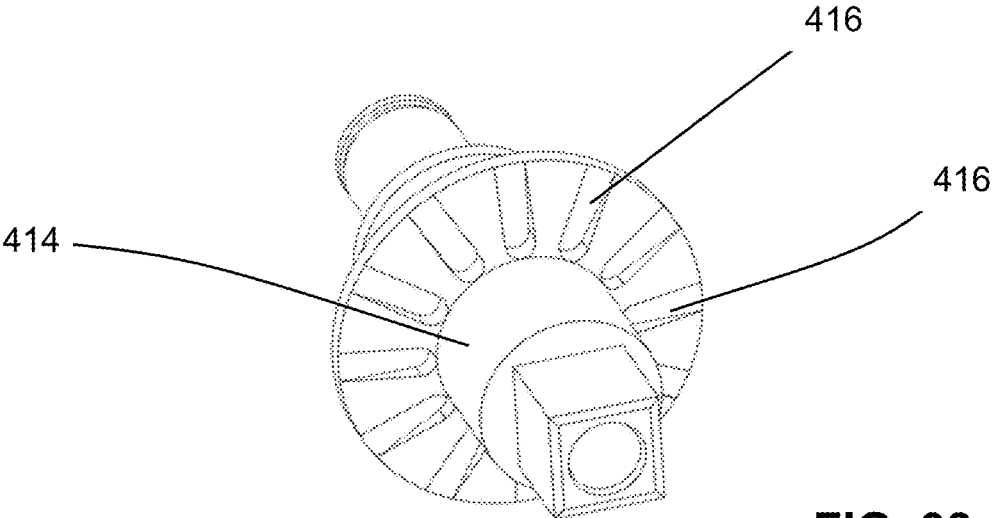

FIG. 38

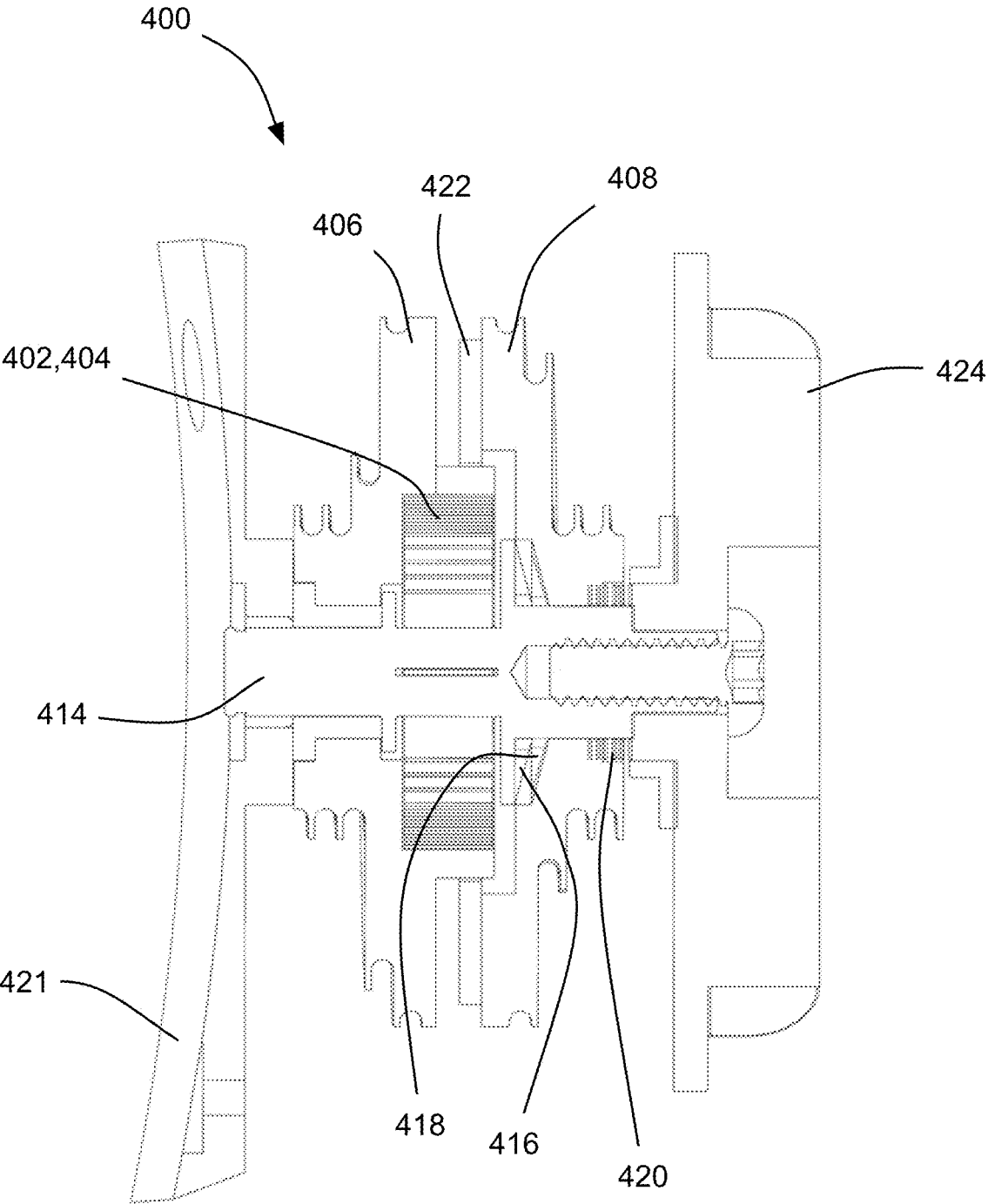

FIG. 39

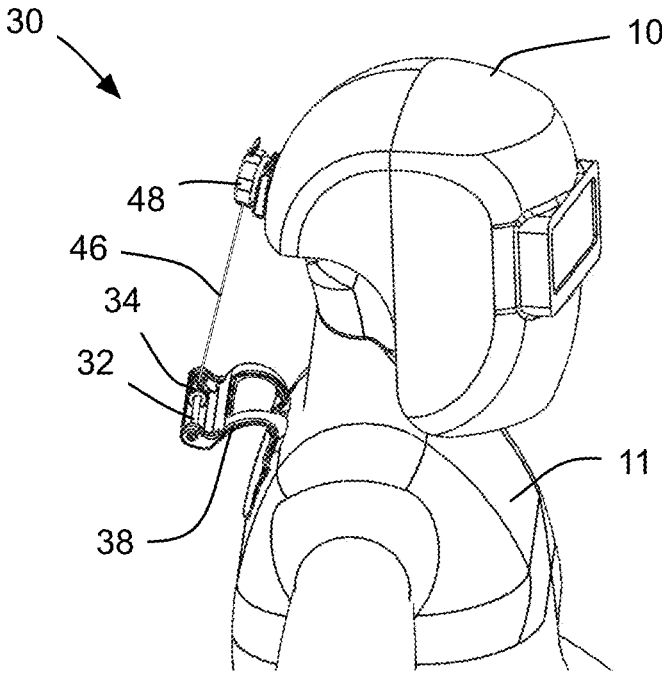

FIG. 40

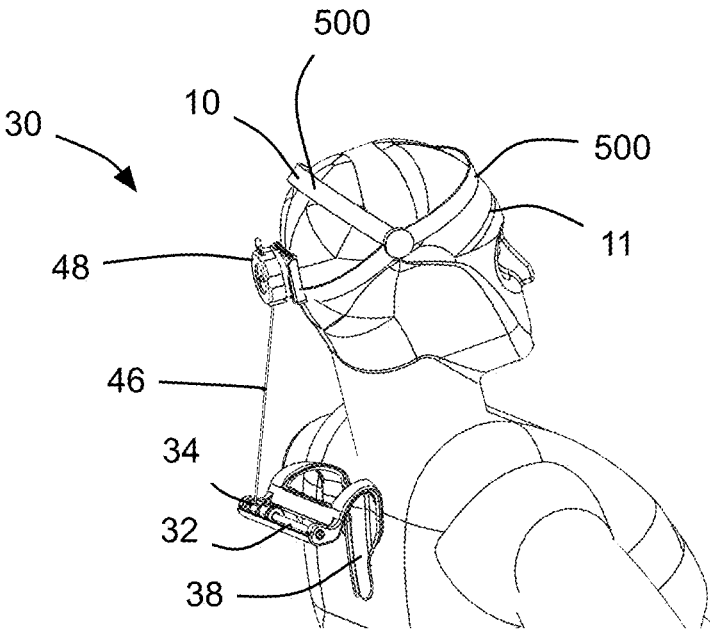

FIG. 41

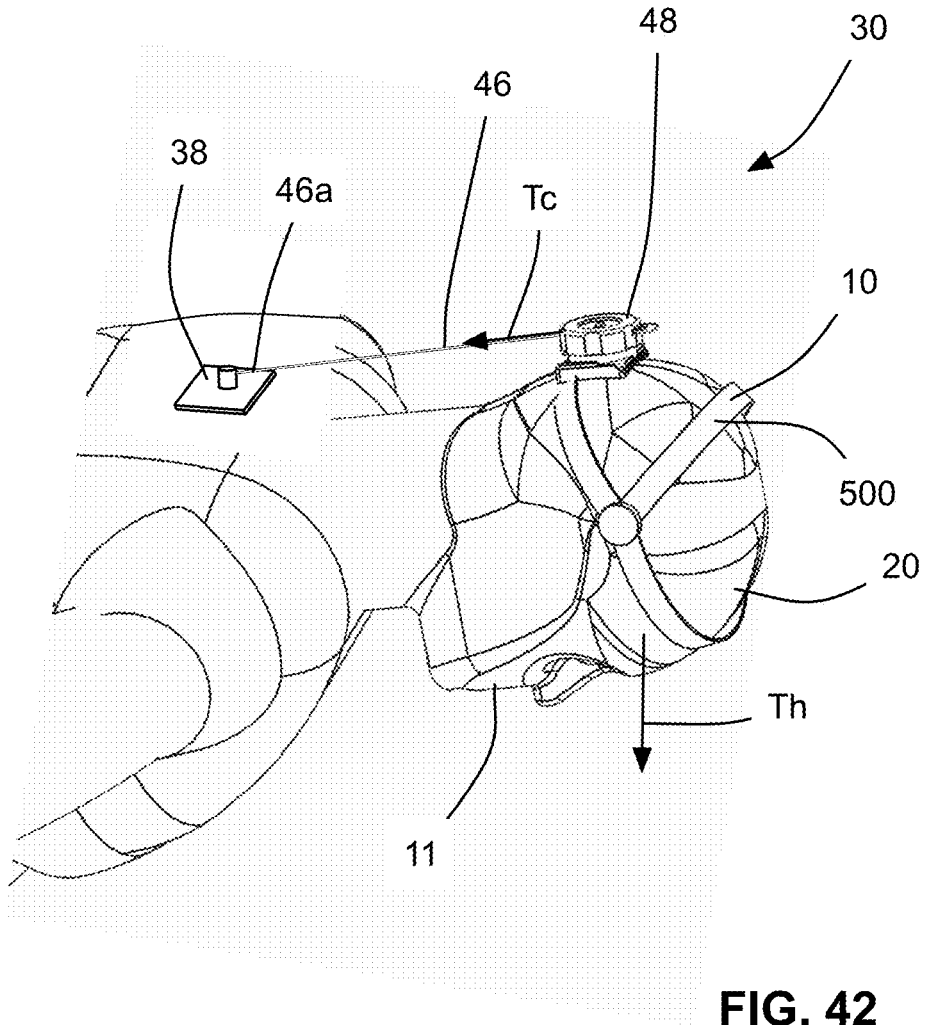

FIG. 42

**SYSTEM FOR MITIGATING
MUSCULOSKELETAL STRESSES FROM
HEAD-RELATED MOMENTS EXERTED ON
A PERSON**

CROSS-REFERENCE TO RELATED
APPLICATIONS

[0001] This application is a divisional of U.S. patent application Ser. No. 15/510,042, filed on Mar. 9, 2017, which is a national phase entry of PCT patent application PCT/CA2015/050877, filed Sep. 10, 2015, which claims the benefit of U.S. provisional application No. 62/048,650, filed Sep. 10, 2014, the contents of which are incorporated herein by reference in their entirety.

FIELD OF INVENTION

[0002] This disclosure relates generally to the field of mitigating stress on the neck muscles of a person, and more particularly to systems for mitigating stresses on wearers of headgear with weighted items that exert moments on the head of the wearer.

BACKGROUND OF INVENTION

[0003] It is generally known that certain activities involve postures or muscle control requirements that can result in stress in the neck muscles of a person. For example, occupations (or pastimes) such as gardening or baking can involve a head-down posture sometimes for a long period of time, which cause unbalanced forces on the neck of the person carrying out the activity. These unbalanced forces result in significant stresses in the neck muscles for the person.

[0004] Other activities entail the wearing of headgear in which one or more weighted items that form part of the headgear are offset from the center of gravity of the headgear and by extension, offset from the centre of gravity or optimal balance point of the head-neck complex of the person. For example, in the armed forces, soldiers regularly wear helmets with night vision goggles on them. When the wearer is standing upright, the weight of the night vision goggles causes a torque to be applied that urges the head of the wearer to tip forward. As a result, wearing a helmet with night vision goggles can result in significant short-duration as well as cumulative stresses on the neck muscles of the wearer. A common solution for this problem is to add a counterweight to the rear of the helmet to offset the torque applied by the night vision goggles.

[0005] There are several problems that result from the use of a counterweight, however. One problem is that, while the counterweight reduces the net torque that is applied to the wearer's head, the addition of the counterweight adds to the amount of weight that the wearer must bear. This adds to the stress on the neck muscles for a wearer who is standing upright. However, certain armed forces personnel, flight engineers on military helicopters for example, spend significant amounts of time lying down on the floor of the helicopter looking down towards the ground during flight. When the wearer is lying down, the added weight of the counterweight adds significantly to the net torque applied to the wearer's head, since both the counterweight and the goggles apply a torque urging the wearer's head downwards. Furthermore, the counterweight adds to the amount of inertia that is associated with the helmet. As a result, when

the wearer turns their head to look to one side or the other, the amount of inertia resisting the rotary head motion by the wearer is larger than it would be without the counterweight. Similar effects are noted with variations of perceived gravitational forces exerted on the system, such as the increase in apparent weight experienced when an aircraft in flight is in a steep coordinated turn. Thus, while the counterweight is helpful in one sense (to neutralize the torque applied by the goggles on an upright wearer), it can increase the stress on the wearer's neck muscles in several other situations.

[0006] It would be beneficial to provide a system for mitigating stresses on a wearer of headgear or that reduces the stresses in the neck muscles of a person, more generally.

SUMMARY

[0007] In an aspect, a stress mitigation system is provided for mitigating stresses in a wearer of a headgear. The headgear is configured to apply a load on the wearer that is offset from a center of gravity of a head of the wearer so as to apply a first torque in a first torque direction on the head of the wearer. The stress mitigation system includes a track, a shuttle, and a flexible elongate connector. The track is mounted to one of the headgear and a bodywear member configured for wearing on a body of the wearer. The track extends generally laterally. The shuttle is movable along the track. The flexible elongate connector is configured to connect between the shuttle and the other of the headgear and the bodywear member. When the wearer is upright, the flexible elongate connector is biased so as to apply a second torque on the headgear in a second torque direction that is generally opposite to the first torque direction. When the head of the wearer pivots about a generally vertical axis, the shuttle is movable laterally along the track so as to maintain the flexible elongate connector in a substantially vertical orientation.

[0008] In another aspect, a stress mitigation system is provided for mitigating stresses in a wearer of a headgear. The headgear is configured to apply a load on the wearer that is offset from a center of gravity of a head of the wearer so as to apply a first torque in a first torque direction on the head of the wearer. The stress mitigation system includes a flexible elongate connector arrangement that is connectable between the headgear and a bodywear member configured for wearing on a body of the wearer. When the wearer is upright, the flexible elongate connector arrangement is biased so as to exert a connector arrangement force in a connector arrangement force direction that is generally opposite to the load force direction on the headgear, and so as to exert a second torque in a second torque direction that is generally opposite to the first torque direction on the headgear. The flexible elongate connector arrangement is positioned on first and second lateral sides of the headgear only.

[0009] In another aspect, a stress mitigation system is provided for mitigating stresses in a wearer of a headgear. The headgear is configured to apply a load on the wearer that is offset from a center of gravity of a head of the wearer so as to apply a first torque in a first torque direction on the head of the wearer. The stress mitigation system includes a first force transfer connector segment and a second force transfer connector segment, and a tensioning device. Each force transfer connector segment has a first end and a second end. The first ends are mounted to one of the headgear and the bodywear member and the second ends are mounted to the

other of the headgear and the bodywear member. The first ends are laterally inboard from the second ends and are vertically spaced from the second ends such that, during pivoting movement of the head of the wearer in a first pivot direction about a vertical axis, the first force transfer connector segment changes orientation towards a vertical orientation and the second force transfer connector segment changes orientation towards a horizontal orientation, and during pivoting movement of the head of the wearer in a second pivot direction about the vertical axis, the first force transfer connector segment changes orientation towards the horizontal orientation and the second force transfer connector segment changes orientation towards the vertical orientation. The tensioning device is configured to reduce tension in any of the first and second force transfer connector segments that changes orientation towards the horizontal orientation and to increase tension in any of the first and second force transfer connector segments that changes orientation towards the vertical orientation.

[0010] In another aspect, a stress mitigation system is provided for mitigating stresses in a wearer of a headgear. The headgear is configured to apply a load on the wearer that is offset from a center of gravity of a head of the wearer so as to apply a first torque in a first torque direction on the head of the wearer. The stress mitigation system includes a flexible elongate connector and a take-up member that is configured for taking up and paying out the flexible elongate member. The flexible elongate connector is configured to connect between the headgear and the bodywear member. The take-up member is configured to take up and pay out the flexible elongate connector and is biased so as to apply tension to the flexible elongate connector. When the wearer is upright, the tension in the flexible elongate connector applies a second torque on the headgear in a second torque direction that is generally opposite to the first torque direction.

[0011] An example of a suitable take-up member is a spool. The spool is connected to receive one end of the flexible elongate connector thereon and is biased in a direction so as to apply tension to the flexible elongate connector.

[0012] In another aspect, a stress mitigation system is provided for mitigating stresses in neck muscles of a person, comprising: a headgear, a track, a shuttle, and a flexible elongate connector. The headgear is configured to mount to the head of the person. The track is mounted to one of the headgear and a bodywear member that is configured for wearing on a body of the person. The track extends generally laterally. The shuttle is movable along the track. The flexible elongate connector is configured to connect between the shuttle and the other of the headgear and the bodywear member. When the person is in a selected position, the flexible elongate connector is biased so as to apply a torque on the headgear in a selected torque direction. When the head of the person pivots about a generally longitudinal axis, the shuttle is movable laterally along the track so as to maintain the flexible elongate connector in a substantially longitudinal orientation.

[0013] In another aspect, a stress mitigation system is provided for mitigating stresses in neck muscles of a person, comprising: a headgear, a flexible elongate connector and a take-up member that is configured for taking up and paying out the flexible elongate member. The headgear is configured to mount to the head of the person. The flexible

elongate connector is configured to connect between the headgear and the bodywear member. The take-up member is connected to take up and pay out the flexible elongate connector and is biased so as to apply tension to the flexible elongate connector. When the person is in a selected position, the flexible elongate connector is biased so as to apply a torque on the headgear in a selected torque direction.

BRIEF DESCRIPTION OF THE DRAWINGS

[0014] The foregoing and other aspects of the disclosure will be more readily appreciated by reference to the accompanying drawings, wherein:

[0015] FIG. 1 is an elevation view of a typical headgear illustrating the centers of gravity of various elements that make up the headgear;

[0016] FIG. 2 is a perspective view of a wearer with a headgear and a stress mitigation system for mitigating stresses in the wearer in accordance with an embodiment of the present disclosure;

[0017] FIG. 3 is a magnified perspective view of the stress mitigation system shown in FIG. 2;

[0018] FIG. 4 is a highly magnified perspective view of a shuttle and track that form part of the stress mitigation system shown in FIG. 2;

[0019] FIG. 5 is an exploded perspective view of the shuttle shown in FIG. 4;

[0020] FIG. 5a is a sectional end view of the shuttle shown in FIG. 4;

[0021] FIG. 6 is an elevation view of the shuttle illustrating the forces acting on it when the wearer of the system turns his/her head;

[0022] FIG. 6a is a perspective view of an aperture through the shuttle shown in FIG. 6;

[0023] FIG. 7 is a side view of the forces acting on the wearer when using the system shown in FIG. 2;

[0024] FIGS. 8a and 8b illustrate release of part of the shuttle in the event that a cable extending from the shuttle snags during operation;

[0025] FIG. 9 is a perspective view of another variant of the shuttle for use on an arcuate track;

[0026] FIG. 10a is a sectional elevation view of the shuttle shown in FIG. 9;

[0027] FIG. 10b is a perspective view of the shuttle shown in FIG. 9, with a portion of the housing of the shuttle removed to show the elements within;

[0028] FIGS. 10c and 10d are additional sectional elevation views of the shuttle shown in FIG. 9;

[0029] FIG. 11 is a perspective view of a tension adjustment device that adjusts tension in a cable and which is part of the stress mitigation system shown in FIG. 3;

[0030] FIG. 12 is an exploded perspective view of the tension adjustment device and a holder for the tension adjustment device shown in FIG. 11;

[0031] FIGS. 13a-13c are perspective views of a portion of the tension adjustment device shown in FIG. 11 with some components removed, illustrating some steps involved in the adjustment of the tension adjustment device;

[0032] FIGS. 14a and 14b are perspective views of a portion of the tension adjustment device shown in FIG. 11 with further components removed to show a cable that is tensioned using the tension adjustment device;

[0033] FIG. 15 is a plan view of the portion of the tension adjustment device shown in FIG. 14;

[0034] FIG. 16 is a perspective view of another embodiment of a stress mitigation system for mitigating stresses in a wearer of a headgear, which includes a shuttle that incorporates rollers instead of a slide bushing;

[0035] FIG. 17 is a perspective view showing the track and rollers from the shuttle shown in FIG. 16;

[0036] FIG. 18 is a perspective view illustrating removal of the track and shuttle from the wearer;

[0037] FIG. 19 is a perspective view of a variant of the track member shown in FIG. 3, that shows adjustability;

[0038] FIG. 20 is a perspective view of another variant of the track member shown in FIG. 3, that shows adjustability;

[0039] FIG. 21 is a perspective view of another embodiment of a stress mitigation system for mitigating stresses in a wearer of a headgear, in which a track and shuttle are mounted to the headgear;

[0040] FIG. 22 is a magnified perspective view of the track and shuttle shown in FIG. 21;

[0041] FIG. 23 is a perspective view of a variant of the system for mitigating stresses shown in FIG. 21, in which the shuttle incorporates rollers instead of a slide bushing;

[0042] FIG. 24 is another perspective view of the variant shown in FIG. 23;

[0043] FIG. 25 is a perspective view of another embodiment of a stress mitigation system for mitigating stresses in a wearer of a headgear, in which there are first and second cable segments extending between the headgear and a cable take-up device;

[0044] FIG. 26 is another perspective view of the embodiment shown in FIG. 25;

[0045] FIG. 27a is an elevation view of the cable take-up device shown in FIG. 25, with certain components removed;

[0046] FIG. 27b is a perspective view of the cable take-up device shown in FIG. 27;

[0047] FIG. 28 is a rear elevation view of a wearer pointing his/her head directly forward to illustrate the forces exerted by the system on the head of the wearer

[0048] FIG. 29 is a rear elevation view of a wearer turning his/her head to one side to illustrate the forces exerted by the system on the head of the wearer;

[0049] FIG. 30 is an elevation view of a wearer turning his/her head to the other side to illustrate the forces exerted by the system on the head of the wearer;

[0050] FIG. 31 is a perspective view of another embodiment of a system for mitigating stresses, which incorporates first and second lifters;

[0051] FIG. 31a is a side elevation view of the embodiment shown in FIG. 31, to illustrate the forces acting on the head of the wearer;

[0052] FIG. 32 is a perspective view of a preload adjustment device that is part of the system shown in FIG. 31;

[0053] FIG. 33 is a sectional perspective view of the preload adjustment device shown in FIG. 32;

[0054] FIG. 34 is a perspective view of the preload adjustment device shown in FIG. 32 with a knob removed;

[0055] FIG. 35 is a sectional perspective view of an alternative tensioning device for use with the stress mitigation system shown in FIG. 25;

[0056] FIG. 36 is an exploded perspective view of the alternative tensioning device shown in FIG. 35;

[0057] FIG. 37 is a perspective view of a spool that is part of the tensioning device shown in FIG. 35;

[0058] FIG. 38 is a perspective view of a shaft that is part of the tensioning device shown in FIG. 35;

[0059] FIG. 39 is a sectional elevation view of the tensioning device shown in FIG. 35, with a second spool rotationally disconnected from a shaft;

[0060] FIG. 40 is a perspective view of a wearer with the stress mitigation system shown in FIG. 2 on a welder's helmet;

[0061] FIG. 41 is a perspective view of a person with the stress mitigation system shown in FIG. 2, with a headgear; and

[0062] FIG. 42 is a perspective view of a person with another embodiment of a stress mitigation system.

DETAILED DESCRIPTION OF EMBODIMENTS

[0063] Reference is made to FIG. 1, which shows a headgear 10 being worn by a wearer 11. The headgear 10 includes a helmet 12, having a helmet center of gravity 12a, a pair of night vision goggles 14, having a night vision goggles center of gravity 14a, a mounting structure 16 for the night vision goggles 14 having its own center of gravity 16a, and a battery pack 18 for providing power to the night vision goggles 14, having its own center of gravity 18a. The wearer 11 has a head 20, which has a center of gravity 20a. When all of the components are taken into account, it can be seen that the overall center of gravity of the headgear 10 (shown at 10a) is not coincident with the center of gravity 20a of the wearer's head 20. As a result, the headgear 10 is configured to apply a load F_h on the wearer 11 that is offset from (in this example, forward of) the center of gravity 20a of the head 20 of the wearer 11 so as to apply a first torque T_1 (which is equal to the load F_h times the offset distance L between the center of gravity 10a of the headgear 10 and the center of gravity 20a of the head 20) in a first torque direction (which is clockwise in the view shown in FIG. 1). The first torque T_1 urges the wearer's head 20 to tip forwards. Furthermore, several elements of the headgear 10, such as the battery pack 18, the night vision goggles 14 and the mounting 16, constitute significant masses that are positioned relatively far from the axis A about which the wearer's head 20 rotates when the wearer 11 turns his/her head in any direction (e.g. when the wearer looks to the left or to the right, or pivots his/her head up or down). Thus, these masses contribute significantly to the polar moment of inertia of the headgear 10.

[0064] Instead of adding a counterweight to the rear of the helmet 12 to adjust the center of gravity 10a of the headgear 10 towards the center of gravity 20a of the wearer's head 20, a system 30 for mitigating stresses on the wearer 11 in accordance with an embodiment of the present disclosure is shown in FIG. 2. The system 30 may be referred to as a stress mitigation system 30.

[0065] Referring to FIG. 3, the stress mitigation system 30 includes a track 32, a shuttle 34 and a flexible elongate connector arrangement 36. The track 32 is mounted to one of the headgear 10 and a bodywear member shown at 38, and the flexible elongate connector arrangement 36 includes a flexible elongate connector 46 that connects between the shuttle 34 and the other of the other of the headgear 10 and the bodywear member 38. In the example shown in FIG. 3, the track 32 with the shuttle 34 mounted thereon, is mounted to the bodywear member 38, and the flexible elongate connector 46 connects between the shuttle 34 and the headgear 10.

[0066] The track 32 may be made from any suitable material such as a metal such as aluminum, or it may be

made from a suitably strong and stiff, low friction polymeric material. The track 32 extends generally laterally. As can be seen in FIG. 4, the track 32 may have a circular cross-sectional shape and may extend directly laterally, with no curvature to its path. The shuttle 34 may also include suitable elements such as linear bearings with recirculating balls.

[0067] The bodywear member 38 is configured for wearing on the body of the wearer 11. For example, the bodywear member 38 may include a plate that fits into and projects from a pocket provided on the back of a garment for the upper torso of the wearer 11. Alternatively the bodywear member 38 may be mounted to the back of a garment for the upper torso by rivets, hook-and-loop material, stitching or the like. Alternatively any other suitable mounting for the bodywear member 38 may be provided.

[0068] The shuttle 34 is movable along the track 32. The shuttle 34 may be movable by any suitable means. For example, in the embodiment shown in FIG. 4, the shuttle 34 includes a shuttle body 70 that holds a bushing 74 with a circular pass-through aperture 76 for mounting the shuttle 34 to the track 32. By providing the track 32 with a circular cross-sectional shape, the shuttle 34 can freely rotate about the track axis as needed. The track axis is shown at A in FIG. 4.

[0069] The flexible elongate connector arrangement 36 is configured to connect the shuttle 34 to the other of the headgear 10 and the bodywear member 38. In the example shown in FIG. 3, the flexible elongate connector arrangement 36 connects the shuttle 34 to the headgear 10. Aside from the flexible elongate connector 46, in the example shown in FIG. 3, the flexible elongate connector arrangement 36 further includes a tensioning device 48 that maintains a selected tension on the flexible elongate connector 46. The flexible elongate connector 36 may be any suitable type of flexible elongate connector such as a cable, a string or a ribbon. In the examples shown herein, the flexible elongate connector 46 is a cable, and may be referred to as a cable for convenience and readability. It will be understood however, that any suitable flexible elongate connector could alternatively be used in embodiments where a cable is described.

[0070] The cable 46 has a first end 46a that is connected to the shuttle 34, and a second end 46b (FIG. 14b) that is connected to a take-up member 54 that is part of the tensioning device 48.

[0071] The tensioning device 48 further includes a tensioning device housing 56, and a flexible elongate connector biasing member 58. The tensioning device housing 56 is a fixed member that acts as a base for holding the other components of the tensioning device 48. A shaft 60 (FIGS. 13a and 14a) is rotatably movable relative to the housing 56 but is held in a selected position by an adjustable locking member 62 that extends from the shaft 60 is selectively engageable with a plurality of housing features 64 on the housing 56 that are arranged at regularly spaced positions about the perimeter of the housing 56. The housing features 64 may be, for example, projections that are each engageable with an aperture 66 on the locking member 62. In FIG. 13a, the locking member 62 holds the shaft 60 in a first angular position by mating with a first housing feature 64a. The locking member 62 is sufficiently flexible so as to be lifted off of the first housing feature 64a that it is engaged with (FIG. 13b), thereby permitting rotation of the locking

member 62 and the shaft 60 to a new, second angular position for locking with a second housing feature 64b (FIG. 13c), so as to lock the shaft 60 in that second angular position.

[0072] The take-up member 54 may be a spool and may be referred to in as spool 54 in reference to at least some of the examples shown in the figures. Any other suitable take-up member may be used alternatively, however.

[0073] The flexible elongate connector biasing member 58 may be any suitable type of biasing member, such as, for example, a clock spring 67, or some other spring or mechanism arrangement with a relatively low, and relatively constant effective force throughout the working range of the stress mitigation system. The clock spring 67 has a first end 67a that is connected to the shaft 60 (e.g. by engagement with a radial slot 60a in the shaft 60), and a second end 67b that engages an aperture 54a in a wall 54b of the spool 54. As a result, the clock spring 67 biases the spool 54 in a direction to wind up the cable 46 so as to apply a selected tension to the cable 46.

[0074] A hand-knob 68 (FIGS. 13a and 13b) may be connected to the shaft 60 (e.g. by virtue of a square or other polygonal aperture in the hand-knob 68 that fits a square or other polygonal profile on the shaft 60). The hand-knob 68 facilitates rotary movement of the shaft 60 and the locking member 62 by the wearer 11 when the locking member 62 is disengaged from the projections 64. As a result, the hand-knob 68 and the adjustable locking member 62 provide the ability for the wearer 11 to adjust the tension provided by the tensioning device 48. It will be understood that the hand-knob 68 is optional, however, and that the shaft 60 could be rotated by any suitable means such as by manually turning the locking member 62 once it is disengaged from the projections 64.

[0075] If it is desired to change the amount of tension present in the cable 46, the wearer 11 may lift the locking member 62 off the projection 64 that it is engaged with and can then turn the hand-knob 68, while keeping the locking member 62 raised, to a new position, thereby changing the amount of flex in the clock spring 67, which in turn changes the spring force applied by it to the spool 54 and thus to the cable 46. Once the selected tension is reached, the wearer can lower the locking member 62 onto a suitable projection 64 nearby so as to fix the rotational position of the shaft 60. In embodiments where the biasing member 58 is a clock spring 67, the tension in the cable 46 remains relatively constant over the range of angular movement that is incurred by the spool 54 during use of the system 30.

[0076] By using the tensioning device 48 to wind the cable 46 onto the spool 54 and to apply tension to the cable 46 (shown as F_c in FIG. 7), the cable 46 (and therefore the flexible elongate connector arrangement 36) applies a second torque T_2 on the headgear 10 that is in a second torque direction that is generally opposite to the first torque direction when the wearer 11 is standing upright, as can be seen in FIG. 7. As a result, the wearer 11 does not have to use their neck muscles to apply a torque to counteract the entirety of the first torque T_1 . Because the tensioning device 48 is capable of adjustment of the tension it applies, the wearer 11 can adjust it so that the torque T_2 substantially cancels the torque T_1 . In the event that the wearer 11 adds weight to the front of the headgear (e.g. if the wearer 11 replaces their night vision goggles with another set of night vision goggles that are weighted differently), the tensioning device 48 can

be adjusted to a different tension so that it again substantially cancels the torque applied by the headgear with the new goggles.

[0077] It will be noted that the stress mitigation system 30 counteracts the torque T1 without the use of a counterweight, as was proposed in the prior art. By avoiding the use of a counterweight, the system 30 reduces the amount of stress incurred by the wearer 11 in order to carry the weight of the headgear 10. Furthermore, by avoiding the use of a counterweight the system 30 reduces the amount of rotational inertia that exists as compared to a system that includes a counterweight.

[0078] By providing the track 32 and the shuttle 34, the system 30 can accommodate the turning of the wearer's head since the shuttle 34 is movable laterally along the track 32 so as to maintain the cable 46 in a substantially vertical orientation, which means that the force Fc in the cable 46 remains substantially vertical even when the wearer's head is turned, so as to counteract the torque T1 from the weighted items such as the night vision goggles, without applying a horizontal torque that urges the wearer's head back towards a center position or providing a rolling moment on the wearer's head. By contrast, if the cable were simply tethered to a fixed point on the back of the wearer, as the wearer would turn their head, the cable would become more and more angled horizontally at which point the tension in the cable would apply a progressively increasing horizontal torque on the wearer's head, resisting the turning of the wearer's head.

[0079] The terms 'horizontal' and 'vertical' as used herein are based on the assumption that the wearer 11 is standing upright and therefore turning his or her head about a vertical axis. It is understood that the device is nonetheless applicable in situations where the wearer 11 is lying down, such as when the wearer 11 is a flight engineer on a military helicopter as described above. In such situations, the term 'vertical' is intended to mean 'longitudinal' (i.e. generally parallel to a longitudinal axis of the wearer), and 'horizontal' is intended to mean 'lateral' (i.e. generally parallel to a lateral axis of the wearer). It will be understood that, some embodiments, the stress mitigation system is capable of at least partially counteracting moments that are applied to the wearer's head via the force exerted through the cable 46. It will be further understood that this force need not be exerted in a strictly vertical direction; the force may be exerted in a direction that is off of vertical while still being offset from the centre of gravity of the head of the wearer so as to provide a counterbalancing torque to the torque applied by the headgear on the wearer's head.

[0080] Referring to FIGS. 4-6a, the shuttle 34 includes a shuttle body 70 and optionally includes a shuttle pivot member 72 that is pivotably connected to the shuttle body 70. The shuttle body 70 may include any suitable means for permitting movement of the shuttle 34 along the track 32. For example, the shuttle body 70 may include a polymer bushing 74 that slidably supports the shuttle 34 on the track 32. The bushing 74 defines a pass-through aperture 76 for receiving the track 32. The pass-through aperture 76 has a length Ls (FIG. 6), a height Hs (FIG. 5) and a width Ws (FIG. 5), as shown in FIG. 5. It will be understood that in embodiments in which the track 32 is a cylindrical rod, as is the case in the example shown in FIGS. 4-6a, the height Hs and the width Ws are both the same and both represent the diameter of the aperture 76. A center of the aperture 76 (i.e.

a point that is positioned at the midpoint of the length Ls, the midpoint of the height Hs and the midpoint width Ws) is shown at C in FIG. 6a.

[0081] The shuttle body 70 further includes a center of gravity, which is shown in FIGS. 6 and 6a as CGsb. It will be noted that the geometric center C of the aperture 76 substantially coincides with the center of gravity CGsb of the shuttle body 70 in the example shown in the figures.

[0082] Referring to FIGS. 5 and 5a, the shuttle body 70 includes two bosses 77a and 77b that are positioned to engage mounting apertures 79a and 79b on the pivot member 72, so as to support the pivot member 72 for pivotal movement about a pivot member axis Apm, wherein the pivot member axis Apm passes through the center C of the pass-through aperture 76 (also shown in FIG. 6a). Furthermore, the connection between the first end 46a of the cable 46 and a cable-receiving feature 80 on the pivot member 72 is rotationally free (e.g. akin to a pin joint).

[0083] When the wearer 11 is standing upright and looking directly forward as shown in FIG. 2, the cable will be oriented directly normal to the track 32 as shown in FIGS. 2 and 3. When the wearer 11 turns their head to the left or right, the tensioning device 48 will become laterally offset from the shuttle 34 which will cause the cable 46 to become angled off of the normal to the track 32. FIG. 6 shows a situation where the wearer 11 has turned their head by some amount, which causes the cable 46 to take on an angled orientation relative to the normal to the track 32. Because of the angle of the cable 46, there is a small component of the force Fc that urges the shuttle 34 to move along the track 32.

[0084] During operation, because the force Fc exerted by the cable 46 on the shuttle 34 passes proximate to the geometric center C of the aperture 76 of the shuttle body 70 (and may also be proximate the centre of gravity CGsb of the shuttle body 70), the force Fc applies substantially no torque on the shuttle body 70 that would tend to cause the bushing 74 to bite into the surface of the track 32. By contrast, if there was no pivot member provided on the shuttle body 70, and the cable 46 instead connected directly to the outer surface of the shuttle body 70, when the wearer 11 turned their head, the force in the cable 46 would cause a certain torque to be applied to the shuttle 34, thereby raising the risk of causing the leading edge of the bushing 74 to bite onto the surface of the track 32 and jam the shuttle 34. Nonetheless, it is contemplated that some embodiments of the stress mitigation system 30 could be constructed in that manner, particularly if the amount of friction between the bushing 74 and the track 32 is sufficiently low, or if the bushing 74 were replaced by some means that was more resistant to jamming (an example of which is described below).

[0085] It will be noted that the bosses 77a and 77b on the shuttle body 70 cooperate with the apertures 79a and 79b on the pivot member 72 to provide two useful features for the shuttle 34 and for the flexible elongate connector arrangement 36 in general. One useful feature is that, with a sufficient amount of force, the pivot member 72 can be removed from the shuttle body 70 non-destructively. The amount of force required for such an act can be selected based on the stiffness provided to the pivot member and the amount of engagement that exists between the bosses 77a and 77b and the apertures 79a and 79b. By making the pivot member 72 removable in this way, a quick release mechanism is provided to separate the headgear 10 from the bodywear member 38 (FIG. 2) so that, if the cable 46

becomes snagged, or if the wearer needs for whatever reason to remove the bodywear member **38** or the headgear **10**, they can do so easily.

[0086] A second useful feature of the bosses **77a** and **77b** and the apertures **79a** and **79b** is illustrated in FIGS. **8a** and **8b**. FIG. **7a** shows a situation where the cable **46** has become snagged on something during use of the headgear **10**. As a result, the angle of the cable **46** causes the cable to pull the pivot member **72** all the way to one end of its travel. When the pivot member **72** reaches an end of its travel (as depicted in FIG. **8a**) a first limit surface **82** on the pivot member **72** engages a first limit surface **84** on the shuttle body **70**. Because of the position of the cable-receiving feature **80**, the tension F_c in the cable **46** applies a torque on the pivot member **72** using the point of engagement between the limit surfaces **82** and **84** as a fulcrum. If the tension F_c in the cable **46** exceeds a selected tension, the torque applied by the cable **46** on the pivot member **72** will overcome the engagement between the bosses **77a** and **77b** and the apertures **79a** and **79b** and the pivot member **72** will be wrenched free from the shuttle body **70**. This prevents damage to the shuttle **34** and to the other components of the stress mitigation system **30** in the event of snagging of the cable **46**. Thus, the bosses **77a** and **77b** and the apertures **79a** and **79b** (which may, more broadly be referred to as boss-receiving features **79a** and **79b**), and optionally the limit surfaces **82** and **84**, may together broadly be referred to as a snag-release system. The first limit surfaces **82** and **84** on the pivot member **72** and the shuttle body **70** respectively are shown on a first side of the pivot member **72** and the shuttle body **70** respectively. The first limit surfaces **82** and **84** cooperate to act as a fulcrum to permit automatic release of a snagged cable **46** for a selected cable tension through a first range of angles of the cable (e.g. a range of angles that is between 0 and about 90 degrees towards the right side of a longitudinal axis in the view shown in FIGS. **8a** and **8b**). The specific cable tension required to cause release of the pivot member **72** from the shuttle body **70** may depend on the specific angle of the cable **46** relative to the pivot member **72**. There is also provided a second limit surface **83** and a second limit surface **85** on an opposing second side of the pivot member **72** and the shuttle body **70** respectively. The second limit surfaces **83** and **85** operate in the same manner as the first limit surfaces **82** and **84**, but for a second range of angles of the cable **46** (e.g. a range of angle that is between 0 and about 90 degrees towards the left side of a longitudinal axis). The first limit surfaces **82** and **84** are described as acting as a fulcrum for a range of angles on the right side of a longitudinal axis (i.e. the axis passing between the head and feet of the wearer **11**), and the second limit surfaces **83** and **85** are described as acting as a fulcrum for a range of angles on the left side of the longitudinal axis. However, it is possible to provide an embodiment wherein for the first limit surfaces **82** and **84** to be repositioned to act as a fulcrum for the left side of the longitudinal axis and for the limit surfaces **83** and **85** to act as a fulcrum for the right side of the longitudinal axis.

[0087] With reference to FIGS. **11** and **12**, another optional way of providing a quick release mechanism to permit separating the headgear **10** from the bodywear member **38**, may be by providing a flange **88** on the tensioner device housing **56** and by providing a base **90** configured to releasably hold the flange **88**. For example, the base **90** may mount fixedly to the back of the helmet **12** and may have an

upwardly facing slot **92**, which is sized to hold the flange **88** on the device housing **56**. During operation the tension F_c in the cable **46** will apply a downward force on the tensioning device **48**, which will keep it held in the slot **92**. When the wearer **11** wishes to remove the tensioning device **48** he or she may lift the device **48** from the slot **92** in the base **90**.

[0088] In an alternative embodiment, the track may extend along a circular arc instead of extending along a straight path as it does in the embodiment in FIG. **3**. The circularly arced track may still be considered to extend laterally, however, even if not directly laterally. In such an embodiment, the other elements that make up the stress mitigation system **30** may be the same as those shown in FIGS. **2-8b** and **11-15**, but with the following difference. The shuttle may include a bushing that is formed to have an arcuately-extending aperture therethrough that matches the curvature of the arcuate arc that the track follows.

[0089] In another embodiment shown in FIGS. **9** and **10a-10d**, the track **110** may follow a circular arc, or it may be arcuate and follow a non-circular arc. In this embodiment, the shuttle, shown at **111** includes a plurality of rollers **112** including a single first roller **112a** and a single second roller **112b** that is positioned directly opposite to the first roller **112a** on the track **110**. The rollers **112** are held in a shuttle housing **113** and are configured to roll along the track **110**. As shown in FIG. **10a**, the rollers **112** have a shallow groove on their contact edge so as to cup the track **110** by some selected amount, so as to center the shuttle **111** on the track **110**. Because there is only a single pair of diametrically opposed rollers **112a** and **112b**, the track is not limited to follow a circular arc. In this embodiment, even though there is no pivot member, the use of rollers instead of a bushing eliminates the problem of digging in caused by a cable tension that does not pass through the center of the aperture through which the shuttle **111** receives the track **110**.

[0090] As shown in FIG. **10b**, the shuttle **111** may include optional brake members **114** that can be positioned in an unbraked position (FIG. **10c**) in which they are spaced from the track **110** and a braked position (FIG. **10d**) in which they are frictionally engaged with the track **110**. In the braked position, the shuttle **111** is inhibited by the brake members **114** from moving along the track **110**, particularly in the embodiment shown in FIG. **9** wherein the track **110** is arcuate. The brake members **114** may be held in their respective positions frictionally in the shuttle housing **113**.

[0091] The braked position may be useful when the wearer **11** wishes to keep their head in substantially one position for a long period of time without the need to turn their head.

[0092] The shuttle **111** includes a snag-release system **120** that differs from the snag-release system provided on the shuttle **34**. The snag-release mechanism **120** includes a ball plunger **122** mounted to the shuttle body **113**. The first end **46a** of the cable **46** is a loop that is captured in a slot **124** by the ball **126** from the ball plunger **122**. In the event that the cable **46** snags on something during operation, the first end **46a** pushes back the ball **126** against the urging of the spring **128** from the ball plunger **122** and releases from the slot **124**.

[0093] FIG. **16** shows an alternative embodiment of a stress mitigation system **150**, which includes a track **152** and a shuttle **154**. The track **152** differs from the track **110** in that the track **152** does not have a circular cross-sectional shape. Instead it has a shape that includes specific shoulders **156**

that are for the purpose of supporting wheels 158 on the shuttle 154. The wheels 158 are shown without the rest of the shuttle 154 in FIG. 18.

[0094] FIG. 17 depicts a feature of the system 150 that is advantageous. Specifically, the system 150 includes a quick release to permit release the track 152 from the bodywear member 38, and another quick release to permit release of the cable 46 from the shuttle 154. This permits the wearer 11 to change out the track and shuttle for another one, either as a replacement one if there is damage to the one they are wearing, or to utilize a different one that is more applicable for a specific activity they are carrying out.

[0095] The quick release is provided in part by a first lateral thrust ball plunger 160 that passes through aligned first and second apertures 162 and 164 in the track 152 and the bodywear member 38, and in part by a second lateral thrust ball plunger 165 that passes through an aperture 166 in the shuttle 154. The bodywear member 38 may include a flange 168 that is retained in a slot 170 in the track 152. The first ball plunger 160 releasably locks the bodywear member 38 and the track 152 together by preventing the withdrawal of the flange 168 from the slot 170. The second ball plunger 165 releasably holds the cable 46 to the shuttle 154. Either ball plunger 165 or 160 may be used to provide a quick release to permit the wearer 11 to disconnect the headgear 10 from the bodywear member 38.

[0096] FIG. 19 shows a variant of the bodywear member 38, which incorporates an adjustment mechanism to permit adjustment of the distance of the shuttle 34 and track 32 are from the center of gravity of the headgear 10, which permits the shuttle 34 and track 32 to be moved out of the way if there is an obstacle that would otherwise interfere with the user's activity. The adjustment mechanism includes a pivot connection between a track support 180 that supports the track 32 and the bodywear member 38, and an over-center cam lock member 182 that may be similar the quick-release structures on a typical bicycle that holds the front wheel releasably to a fork on a bicycle frame. When the cam lock member 182 is levered to a locked position, the elements that engage one another as part of the pivot connection are clamped so as to frictionally lock the position of the track support 180.

[0097] The adjustment mechanism shown in FIG. 19 permits adjustment of the position of the track 32 and shuttle 34 via a pivoting movement of a track support. FIG. 20 shows another variant of the bodywear member 38, which incorporates another adjustment mechanism, which permits adjustment of the position of the track 32 and shuttle 34 via linear movement. Each of a pair of fasteners 184 may extend through a slotted aperture 186 in the track support member shown at 188, and may further pass through another aperture (not shown) in the bodywear member 38. The other aperture that is not shown may be a threaded circular aperture and need not be slotted. When the fasteners 184 are tightened the track 32 is locked in position. When the fasteners are loosened the track support member 188 can be slid linearly to a new desired position at which point the fasteners 184 can be tightened to lock the position of the track 32.

[0098] Reference is made to FIG. 21, which shows another embodiment of a stress mitigation system 200. The stress mitigation system 200 may be similar to the stress mitigation system 30, but provides a tensioning device 202 that is mounted to a bodywear member 204, and a track 206 that is mounted to the headgear 10. The shuttle is shown at 208. A

cable 209 extends between the shuttle 208 and the tensioning device 202. The track 206 may be similar to the track 32 and may have a circular cross-sectional shape, but extends along an arcuate path. For example, the track 206 may extend along a circular arc. The shuttle 208 may be any suitable type of shuttle shown in the figures. In the example shown, the shuttle 208 comprises a plate 210 (FIG. 22) with a bushing 211 that has a rounded profile and defines a pass-through aperture 212 for the track 206. The cable 209 (FIG. 21) may be similar to the cable 46. The tensioning device 202 may be similar to the tensioning device 48 but is fixedly connected to a bodywear member, such as bodywear member 204. The tensioning device 202 is shown in FIG. 21 connected to the bodywear member 204 by large solid connector member 214; however, they may be connected by any suitable type of connection.

[0099] FIGS. 23 and 24 show an embodiment of a stress mitigation system 220 in which the track (shown at 222) includes specific shoulders 224 for supporting rollers 226 on a shuttle 228. The track 222 is mounted in this embodiment to the headgear 10. The tensioning device 202 and the cable 209 may be the same as they are in the embodiment in FIG. 21.

[0100] Reference is made to FIG. 25, which shows another embodiment of a stress mitigation system 250. The stress mitigation system 250 includes a tensioning device 252, a first spool 254 (FIG. 26), a second spool 256 (FIG. 27), a first cable 258 and a second cable 260. The first cable 258 has a first force transfer cable segment 258a and a first spool engagement cable segment 258b. Similarly, the second cable 260 has a second force transfer cable segment 260a and a second spool engagement cable segment 260b. Each force transfer cable segment 258a and 260a has a first end 262 and a second end 264. The first ends 262 of the force transfer cable segments 258a and 260a are mounted to one of the headgear 10 and the bodywear member 38. In the example shown in FIG. 25, the first ends 262 are mounted to the headgear 10, via a first end mount 266, which will be described in further detail below. The second ends 264 are mounted to the other of the headgear 10 and the bodywear member 38. In the example shown in FIG. 25, the second ends 264 are mounted to the bodywear member 38.

[0101] The first ends 262 are laterally inboard from the second ends 264 and are vertically spaced from the second ends 264 such that, during pivoting movement of the head 20 of the wearer 11 in a first pivot direction PD1 about the vertical axis A, the first force transfer cable segment 258a changes orientation towards a vertical orientation (FIG. 29) and the second force transfer cable segment 260a changes orientation towards a horizontal orientation, and during pivoting movement of the head 20 of the wearer 11 in a second pivot direction PD2 about the vertical axis A, the first force transfer cable segment 258a changes orientation towards the horizontal orientation (FIG. 30) and the second force transfer cable segment 260a changes orientation towards the vertical orientation.

[0102] Referring to FIGS. 26 and 28, the second ends 264 of the first and second force transfer cable segments 258a and 260a engage a guide feature 268 (FIG. 28) at each lateral end of the bodywear member 38 and connect to the spool engaging cable segments 258b and 260b, which extend through pass-through apertures 270 (FIG. 28) in the bodywear member 38 and are received on the first and second spools 254 and 256 respectively (FIG. 26).

[0103] The tensioning device 252 maintains tension in the first and second cables 258 and 260 by means of a biasing member 272 that may be referred to as a cable segment biasing member 272. The biasing member 272 may be, for example, a clock spring 274 that has a first end 274a and a second end 274b. The first end 274a may be engaged with a wall 276 (by passing through a radial slot in the wall 276 as shown in FIG. 26) wherein the wall 276 is part of the first spool 254. The second end 274b may be engaged with a shaft 278 (e.g. may be received in a slot in the shaft 278 as shown in FIG. 27b) that is part of the second spool 256. The first spool 254 may be rotatably supported on the shaft 278 (e.g. via a bushing), so that the first and second spools 254 and 256 are rotatable relative to one another. By connecting the ends 274a and 274b of the clock spring 274 to the two spools 254 and 256, the spools 254 and 256 are biased in selected rotational directions that are opposite to one another and which maintain tension in the first and second cables 258 and 260.

[0104] The tensions in the two cables 258 and 260 are shown at TC1 and TC2 respectively in FIGS. 28-30. FIG. 28 represents a situation where the head 20 of the wearer 11 is pointing directly forward. In such an instance, the cable segments 258 and 260 each have respective tensions TC1 and TC2. Because the angles of the force transfer cable segments 258a and 260a are substantially equal and opposite, it will be appreciated that the lateral components of the tensions TC1 and TC2 are substantially equal and opposite and therefore substantially cancel each other out so that there is substantially no net torque acting on the wearer's head 20 urging it about the vertical axis A. The vertical components of the tensions TC1 and TC2 add to one another and cooperate to apply a torque to the head 20 of the wearer 11 to counteract the torque applied by the weighted elements such as the night vision goggles 14 shown in FIG. 25.

[0105] When the wearer 11 turns his/her head 20 in the first pivot direction PD1 (FIG. 25), the angles of the force transfer cable segments 258a and 260a change such that the first cable segment 258a moves towards a vertical orientation and the second cable segment 260a moves towards a horizontal orientation. If the tensions TC1 and TC2 in the two cable segments 258a and 260a remained the same magnitude, then the tension TC2 in the cable segment 260a would apply a significant lateral torque on the head 20 of the wearer 11 that would be substantially unopposed by the tension TC1 in the first cable segment 258a. Similarly, when the wearer 11 turns his/her head 20 in the second pivot direction PD2 (FIG. 25), if the tensions TC1 and TC2 remained the same magnitude, then the tension TC1 in the cable segment 258a would apply a significant lateral torque that would be substantially unopposed by the tension TC2. These resultant lateral torques would be experienced by the wearer 11 as a resistance to turning of his/her head 20, which would be undesirable, and so to address this, the tensioning device 252 is configured to reduce tension in any of the first and second force transfer connector segments 258a and 260a that changes orientation towards the horizontal orientation and to increase tension in any of the first and second force transfer connector segments 258a and 260a that changes orientation towards the vertical orientation.

[0106] To accomplish this, the first and second spools 254 and 256 each have a groove (shown at 280 and 282 respectively in FIGS. 26 and 27a) for retaining the associated one of the first and second spool engaging connector segments

258b and 260b, wherein the groove 280 or 282 on each spool 254 or 256 has a progressively increasing diameter from a first groove end 284 to a second groove end 286, such that when the spool 254 or 256 pays out the associated spool engaging connector segment 258b or 260b, the associated spool engaging connector segment 258b or 260b leaves the groove 280 or 282 at a progressively increasing diameter and when the spool 254 or 256 reels in the associated spool engaging connector segment 258b or 260b, the associated spool engaging connector segment leaves the groove 280 or 282 at a progressively decreasing diameter. By changing the diameter at which the first and second spool engaging cable segments 258b and 260b leave the spools 254 and 256, the spring force from the biasing member 272 results in a changing tension TC1 and TC2 in the cable segments 258b and 260b and therefore in the cable segments 258a and 260a. In other words, the tension in either cable 258 or 260 depends on the diameter at which that cable 258 or 260 leaves the associated groove 280 or 282 on the associated spool 254 or 256. In this way, as the wearer 11 turns his/her head 20, the tension drops in the cable segment 258a or 260a that reorients towards a more horizontal orientation thereby reducing any lateral torque applied to the wearer's head 11, and the tension increases in the cable segment 258a or 260a that reorients towards a more vertical orientation to ensure that a sufficient torque is applied to the wearer's head 11 to counteract the torque applied by elements such as the night vision goggles 14.

[0107] Reference is made to FIG. 31, which shows another embodiment of a stress mitigation system 300. The stress mitigation system 300 differs from the other systems described herein in the sense that the stress mitigation system 300 applies a force that lifts the head 20 of the wearer 11 to counteract the torque applied by the loads such as the night vision goggles and also to counteract the forces applied by the loads such as the night vision goggles 14.

[0108] The system 300 includes a flexible elongate connector arrangement 302 that is connectable between the headgear 10 and a bodywear member 38 configured for wearing on a body of the wearer 11. In the example shown in FIG. 31, the flexible elongate connector arrangement 302 includes first and second flexible elongate connectors 304 and 306, each of which extends between a body mount member 308 on a bodywear member 38, and a headgear mount member 310 on the headgear 10. At least one of the body mount member 308 and the headgear mount member 310, there is provided a lifting force adjustment device 312.

[0109] Each flexible elongate connector 304 and 306 may be an elongate semi-rigid member that is bendable but that has a restoring force associated with bending flexure. An example of a suitable connector 304 or 306 is an elongate helical spring that extends along a generally C-shaped path between a first end 314 at the headgear mount member 310 and a second end 316 at the bodywear mount member 308. The connectors 304 and 306 apply lifting forces FHS1 and FHS2 at the headgear mount members 310 that are generated from the restoring force in the connectors 304 and 306 which urge the connectors 304 and 306 towards a straight (i.e. non-C-shaped) configuration. Another example of a connector 304 or 306 would be a semi-rigid elastomeric member, or a metallic ribbon member.

[0110] The lifting force adjustment device 312 includes a base 318, an end connector 320 that is configured to receive the first end 314 of the associated elongate flexible semi-

rigid connector **304** or **306**, and a position adjustment mechanism **321** that permits adjustment of the position of the end connector **320** relative to the base **318** so as to adjust the amount of flexure (and therefore restoring force, and therefore lifting force) is generated by the connector **304** or **306**. The amount of flexure, in the embodiment shown in FIG. **31**, may be directly related to the overall bend angle that is present in the connector **304** or **306**.

[0111] As shown in FIG. **31**, the base **318** may mount fixedly or removably to the headgear **10**, by way of adhesive, fasteners or any other suitable way. The end connector **318** may include an end receiving aperture **322** (FIGS. **32** and **33**) that is sized to snugly receive the first end **314** of the associated connector **304** or **306**. The end connector **320** is rotatable about a shaft **324** on the base **318**. A plurality of spring biased ball plungers **326** (e.g. spring biased by Belleville washers **328**) extend from the end connector **320** into detents **330** provided on the base **318** to releasably hold the end connector **318** at a selected orientation on the base **318**, so as to cause a selected amount of angular flexure of the associated connector **304** or **306**. Alternatively any other suitable position adjustment mechanism may be used.

[0112] It will be noted that the headgear **10** described above are but an example of the type of headgear that could benefit from any of the stress mitigation systems described herein. For example, other types of headgear that could benefit from such systems include virtual reality headgear, surgical headgear that include an eyepiece for magnifying an image and illuminating an area of a patient for the surgeon, or a safety helmet with a video camera mounted on it, such as those used by mountain bikers, or motorcyclists.

[0113] In the embodiment shown in FIGS. **31-34**, the connectors **304** and **306** are configured to apply a force at a point forward of the center of gravity of the headgear so as to apply a torque that is opposite to the torque applied by the offset load urging the head of the wearer **11** to tilt forward and downwards. It will, however, be appreciated that the offset load could be positioned in some embodiments, in a position in which they apply a torque urging the wearer's head **11** to pivot upwards. In such cases, the connectors **304** and **306** may be configured to exert a lifting force rearward of the center of gravity of the headgear **10** so that the lifting force applies a torque that opposes the torque generated by the offset load.

[0114] Reference is made to FIGS. **35-39**, which show a tensioning device **400** that could be used as part of the stress mitigation system **250** instead of the tensioning device **252** (FIG. **25**). The tensioning device **400** may be similar to the tensioning device **252** shown in FIG. **25**, but includes a tension adjustment mechanism that permits adjustment of the tension in the first and second cables **258** and **260**.

[0115] The tensioning device **400** maintains tension in the first and second cables **258** and **260** by means of a biasing member **402** that may be similar to the biasing member **272** (and which may be a clock spring **404**). Two spools are shown in FIG. **35** at **406** and **408**, and may be similar to the spools **254** and **256** in FIG. **26**. The spools **406** and **408** are shown to face away from one another in FIG. **35**, however it is possible in some embodiments for the spools **406** and **408** to face towards one another, while still keeping the clock spring **404** between them.

[0116] The clock spring **404** in the embodiment in FIGS. **35-39** is connected at its first end **404a** to a wall **410** (by passing through a radial slot **412** (FIG. **36**) in the wall **410**)

which is part of the first spool **406**, and is connected at its second end **404b** to a shaft **414** (e.g. via a slot **416** (FIG. **35**) in the shaft **414**). The shaft **414**, in the embodiment shown in FIGS. **35-39** is separate from the second spool **408** but is releasably connectable to the second spool **408**. A plurality of depressions **416** that are on one of the shaft **414** and the second spool **408** mesh with at least one tooth **418** (FIG. **37**) on the other of the shaft **414** and the second spool **408** to lock the shaft **414** and the second spool **408** rotationally with one another. In the embodiment shown the depressions **416** are on the shaft **414** and there are a plurality of teeth **418** on the second spool **408**.

[0117] A spool locking biasing member, shown at **420** in FIG. **35**, biases the second spool **408** and the shaft **414** into engagement with one another such that the depressions and teeth **416** and **418** mesh with one another. The biasing member **420** may be any suitable type of biasing member such as a helical compression spring that has a first end that abuts a tensioning device housing **421** and a second end that abuts the second spool **408**.

[0118] When it is desired to adjust the tension in the cables **258** and **260**, the wearer **11** can move a separator plate **422** to remove the second spool **408** from rotational engagement with the shaft **414** (FIG. **39**). When the second spool **408** is rotationally disconnected from the shaft **414**, the shaft **414** is now free to be rotated relative to the second spool **408**. Thus, the wearer (not shown in FIG. **35**) can rotate the shaft **414** using a handle **424** that is connected thereto, so as to change the amount of preload in the clock spring **404**, since the shaft **414** has the second end **404b** of the clock spring **404** connected thereto. Once the desired amount of preload exists in the clock spring **404**, the wearer can release the separator plate **422**, thereby permitting the biasing member **420** to bring the second spool **408** back into engagement with the shaft **414** to lock them together rotationally.

[0119] Put another way, the second spool **408** is positionable in a first position (FIG. **35**) in which it is rotationally locked with the shaft **414** and therefore with the second end **404b** of the clock spring **404**, and a second position (FIG. **39**) in which it is rotationally disconnected with the shaft **414** and therefore with the second end **404b** of the clock spring **404**.

[0120] While a shaft **414** is provided as the element that is engaged with the second end **404b** of the clock spring **404** and that is the intermediate member between the clock spring **404** and the second spool **408**, it will be understood that any other suitable member may act as an intermediate member between the clock spring **404** and the second spool **408** and may receive the second end **404b** of the clock spring **404**.

[0121] As can be seen in FIG. **36**, bushings **430** and **432** and a thrust member **434** are provided to support the shaft **414** for rotation relative to the housing **421**, the first spool **406** relative to the shaft, and support the end of the biasing member **420**

[0122] Reference is made to FIGS. **40** and **41**, which show other applications for stress mitigation systems described herein. For example, in FIG. **40**, the stress mitigation system **30** is shown being used to control stresses incurred when wearing a welder's helmet (i.e. when the headgear **10** is a welder's helmet). In FIG. **41**, the stress mitigation system **30** is shown being used with a headgear **10** that includes straps and the like but where there is no helmet. An example of such a headgear **10** could be used in conjunction with virtual

reality goggles, where a helmet is not necessary. Another example would be when a welder's mask is used instead of a welder's helmet. Yet another example would be a surgeon who is wearing lead-lined glasses during certain types of surgery to protect against radiation exposure. It will be understood that many other applications exist for the stress mitigation systems shown herein.

[0123] Also, in relation to FIG. 41, there are situations in which a person may incur stress in their neck muscles even when they are not wearing a headgear with offset-weighted items on it. For example, in situations where a person spends long periods of time with their head facing downwards, their head itself is essentially held in cantilever to their body and stresses the neck muscles of the person. Some examples of such situations include: a bicycle rider whose body posture can be tilted forward for long periods, a gardener who is generally looking downwardly for long periods to carry out his/her work, a person who is lying on their front and either looking forward or looking downward (such as the aforementioned helicopter engineer, regardless of whether or not they are wearing a helmet or goggles or any other head-mounted device), or a disabled or sick person who may spend long periods sitting with their head tilted forward because they are too weak or otherwise unable to hold their head upright. In such situations it may be advantageous to provide a headgear, such as the headgear 10 shown in FIG. 41 (and which may comprise simple straps shown at 500) which permits the mounting of the end 46b of the flexible elongate connector 46 to the wearer's head 11, (indirectly via the tensioning device 48) or which permits the mounting of any of the other embodiments described herein to the wearer's head, as appropriate. Thus, in an embodiment, a stress mitigation system is provided for mitigating stresses in neck muscles of a person, comprising: a headgear (e.g. headgear 10 shown in FIG. 41), a track (e.g. track 32 shown in FIG. 41), a shuttle (e.g. shuttle 34 shown in FIG. 41), and a flexible elongate connector (e.g. cable 46 shown in FIG. 41). The headgear is configured to mount to the head 11 of the person. The track is mounted to one of the headgear and a bodywear member (e.g. bodywear member 38 shown in FIG. 41) that is configured for wearing on a body of the person. The track extends generally laterally. The shuttle is movable along the track. The flexible elongate connector is configured to connect between the shuttle and the other of the headgear and the bodywear member. In a selected position, the flexible elongate connector is biased so as to apply a torque on the headgear in a selected torque direction. When the head of the wearer pivots about a generally longitudinal axis, the shuttle is movable laterally along the track so as to maintain the flexible elongate connector in a substantially longitudinal orientation.

[0124] In any of the embodiments described above, it is possible that some form of headgear could be provided as part of the stress mitigation system, that connects to, or that may be separate from, any headgear that a person may be wearing that has an offset-weighted item on it.

[0125] For example, in an embodiment, a stress mitigation system could be provided for mitigating stresses in neck muscles of a person, that is similar to the embodiment shown in FIG. 41, but wherein the track 32 and shuttle 34 are omitted, and the first end 46a of the cable 46 is mounted directly to the bodywear member 38 such that the first end of the cable 46 is fixed in position laterally. An example of such an embodiment is shown in FIG. 42. In the embodiment

in FIG. 42, the stress mitigation system includes: the headgear 10, the flexible elongate connector 46 and a tensioning device 48 that includes a take-up member (e.g. the spool 54 shown in FIGS. 14a and 14b) that is configured for taking up and paying out the flexible elongate member 46 and is biased so as to apply tension to the flexible elongate connector 46. The headgear 10 is configured to mount to the head of the person. The flexible elongate connector 46 is configured to connect between the headgear 10 and the bodywear member 38. When the person is in a selected position, the flexible elongate connector 46 is biased so as to apply a selected torque on the headgear 10 in a selected torque direction. In the example shown in FIG. 42, the person's body is generally horizontal and the weight of their head 20 applies a torque T_h on their head 11. The selected torque T_c from the flexible elongate connector 46 is applied in a selected direction that is opposed to the torque T_h from the weight of the head 20 of the wearer 11 so as to counteract (partially or fully) the torque T_h .

[0126] Throughout this disclosure, the use of a spool has been described as being used to take up and pay out some of the length of the cable 46 so that the effective length of the cable 46 could adjust as needed based on the position of the person's head. It will be understood, however, that the spool is but one example of a take-up member that could be used to take up and pay out some length of the cable 46. Any other suitable take-up member could alternatively be used. For example, a block-and-tackle (not shown) that includes at least two pulleys, wherein one of the pulleys is biased by a compression spring away from the other pulley could be used to take up and pay out some length of the cable 46 as needed. The compression spring would act as a biasing member to maintain tension in the cable 46.

[0127] Those skilled in the art will understand that a variety of modifications may be effected to the embodiments described herein without departing from the scope of the appended claims.

1. A stress mitigation system for mitigating stresses in a wearer of a headgear, wherein the headgear is configured to apply a load on the wearer that is offset from a center of gravity of a head of the wearer so as to apply a first torque in a first torque direction on the head of the wearer, the stress mitigation system comprising:

a flexible elongate connector arrangement that is connectable between the headgear and a bodywear member configured for wearing on a body of the wearer;

wherein, when the wearer is upright, the flexible elongate connector arrangement is biased under flexure so as to exert a connector arrangement force in a connector arrangement force direction that is generally opposite to the load force direction on the headgear, and so as to exert a second torque in a second torque direction that is generally opposite to the first torque direction on the headgear, wherein the flexible elongate connector arrangement is positioned on first and second lateral sides of the headgear only.

2. A stress mitigation system as claimed in claim 1, wherein the flexible elongate connector arrangement includes a first elongate semi-rigid connector that extends along a generally C-shaped path between the headgear and the bodywear member on a first lateral side of the headgear, and a second elongate semi-rigid connector that extends

along a generally C-shaped path between the headgear and the bodywear member on a second lateral side of the headgear.

3. A stress mitigation system as claimed in claim 2, wherein each elongate semi-rigid connector is an elongate helical spring.

4. A stress mitigation system as claimed in claim 2, wherein each elongate semi-rigid connector is oriented to flex in a substantially vertical plane.

5. A stress mitigation system as claimed in claim 2, wherein each elongate semi-rigid connector is oriented to flex in a substantially vertical plane that extends substantially sagittally.

6. A stress mitigation system as claimed in claim 2, wherein, for each elongate semi-rigid member there is a lifting force adjustment device that is configured to control the amount of flexure is present in the elongate semi-rigid member.

7. A stress mitigation system as claimed in claim 6, wherein the lifting force adjustment device includes a base, an end connector that is shaped to receive a first end of the elongate semi-rigid member, and wherein the end connector is movably mounted to the base, wherein movement of the end connector relative to the base adjusts an amount of flexure that is present the elongate semi-rigid member, thereby adjusting a restoring force of the elongate semi-rigid member.

8. A stress mitigation system for mitigating stresses in a wearer of a headgear, wherein the headgear is configured to apply a load on the wearer that is offset from a center of gravity of a head of the wearer so as to apply a first torque in a first torque direction on the head of the wearer, the stress mitigation system comprising:

a first force transfer cable segment and a second force transfer cable segment, wherein each force transfer cable segment has a first end and a second end, wherein the first ends are mounted to one of the headgear and the bodywear member and the second ends are mounted to the other of the headgear and the bodywear member, wherein the first ends are laterally inboard from the second ends and are vertically spaced from the second ends such that, during pivoting movement of the head of the wearer in a first pivot direction about a vertical axis, the first force transfer cable segment changes orientation towards a vertical orientation and the second force transfer cable segment changes orientation towards a horizontal orientation, and during pivoting movement of the head of the wearer in a second pivot direction about the vertical axis, the first force transfer cable segment changes orientation towards the horizontal orientation and the second force transfer cable segment changes orientation towards the vertical orientation; and

a tensioning device including a cable segment biasing member is biased under flexure so as to apply a restoring force that increases tension in any of the first

and second force transfer cable segments that changes orientation towards the vertical orientation, and reduces tension in any of the first and second force transfer cable segments that changes orientation towards the horizontal orientation.

9. A stress mitigation system as claimed in claim 8, wherein the tensioning device includes a first spool and a second spool, wherein the cable segment biasing member that extends between the first and second spools,

and wherein the first force transfer cable segment connects to a first spool engaging cable segment which is received on the first spool and wherein the second force transfer cable segment connects to a second spool engaging cable segment which is received on the second spool.

10. A stress mitigation system as claimed in claim 9, wherein the first and second spools each have a groove for retaining the associated one of the first and second spool engaging connector segments, wherein the groove on each of the first and second spools has a progressively increasing diameter from a first groove end to a second groove end, such that when one of the first and second spools pays out the associated one of the first and second spool engaging cable segments, the associated one of the first and second spool engaging cable segments leaves the groove at a progressively increasing diameter and when said one of the first and second spools reels in the associated one of the first and second spool engaging connector segments, the associated one of the first and second spool engaging cable segments leaves the groove at a progressively decreasing diameter.

11. A stress mitigation system as claimed in claim 9, wherein the tensioning device is configured to permit adjustment of the tension in the first and second force transfer cable segments.

12. A stress mitigation system as claimed in claim 11, wherein the cable segment biasing member that has a first end that is connected to the first spool, and a second end that is connected to an intermediate member that is removably connectable to the second spool over a range of angular positions.

13. A stress mitigation system as claimed in claim 12, wherein the tensioning device includes a spool locking biasing member that urges the second spool to a first position in which the second spool is locked rotationally with the intermediate member at a first selected position in the range of angular positions, and wherein the second spool is movable to a second position in which the second spool is rotationally disconnected from the intermediate member and movable to as second selected position in the range of angular positions.

14. A stress mitigation system as claimed in claim 8, wherein the cable segment biasing member is a clock spring.

* * * * *