



(11) **EP 1 972 537 B1**

(12) **EUROPEAN PATENT SPECIFICATION**

(45) Date of publication and mention of the grant of the patent:  
**09.12.2009 Bulletin 2009/50**

(51) Int Cl.:  
**B62K 23/06<sup>(2006.01)</sup> B62L 3/02<sup>(2006.01)</sup>**

(21) Application number: **08004471.2**

(22) Date of filing: **11.03.2008**

(54) **Reach adjust for a handlebar-mounted lever assembly**

Griffweiteneinstellung für eine an einem Lenker montierte Hebelanordnung

Ajustement en hauteur pour ensemble de levier assemblé sur un guidon

(84) Designated Contracting States:  
**DE FR NL**

(30) Priority: **21.03.2007 US 689461**

(43) Date of publication of application:  
**24.09.2008 Bulletin 2008/39**

(73) Proprietor: **SRAM, LLC.**  
**Chicago, IL 60642 (US)**

(72) Inventors:  
• **Orrico, James**  
**Chicago,**  
**IL 60614 (US)**  
• **Morris, Matt**  
**Chicago,**  
**IL 60647 (US)**

• **Feurstein, Paul**  
**Chicago,**  
**IL 60647 (US)**

(74) Representative: **Thum, Bernhard**  
**Wuesthoff & Wuesthoff**  
**Patent- und Rechtsanwälte**  
**Schweigerstrasse 2**  
**81541 München (DE)**

(56) References cited:  
**EP-A- 1 342 655 EP-A- 1 759 979**  
**WO-A-2007/026383 DE-U1- 9 415 887**  
**JP-A- 10 129 293 JP-A- 2003 261 085**  
**US-A- 4 348 916**

**EP 1 972 537 B1**

Note: Within nine months of the publication of the mention of the grant of the European patent in the European Patent Bulletin, any person may give notice to the European Patent Office of opposition to that patent, in accordance with the Implementing Regulations. Notice of opposition shall not be deemed to have been filed until the opposition fee has been paid. (Art. 99(1) European Patent Convention).

## Description

### Background of the Invention

[0001] The present invention relates to handlebar-mounted lever assemblies, and more particularly, to a lever assembly that includes a reach adjust mechanism.

[0002] Typically, a lever assembly may be a brake lever assembly or a shift lever assembly. These assemblies are mountable to a handlebar for use on a bicycle, and the like, to actuate a control cable extending between the lever assembly and a brake or gear-change device. Alternatively, the lever assembly may be used in a hydraulic brake system or the like. Typically, the distance between the lever and the handlebar, known as the reach, is fixed and set to accommodate an average-sized hand. Accordingly, a fixed-reach lever may be positioned too far from the handlebar for a rider with smaller hands to comfortably reach.

[0003] To solve this problem, the lever assembly may include a reach adjust mechanism. One example of a reach adjust mechanism is a removable spacer insertable between the housing and the lever. One disadvantage of the spacers is that they provide only one increment of reach adjust. Another disadvantage is that the discrete spacer may be lost. Another example of a reach adjust mechanism is a screw or bolt threaded directly into the housing and engageable with the lever to position the lever relative to the handlebar. However, when the threads on the housing become worn or stripped, the entire housing has to be replaced. A further example of a reach adjust mechanism is disclosed in JP 10 129293 A. JP 10 129293 A describes an easily adjustable operation lever device for a motorcycle, having a support member, a lever with a stopper, and a reach adjust mechanism comprising a cam and a cam seat. The cam has six cam surfaces each differently spaced from an axis of the cam and defining one of six user-selectable positions. In a rest position of the lever, the stopper abuts on the one of the cam surfaces selected by a user by turning the cam. However, when turning the cam, the edges between adjacent cam surfaces become worn, and thus, precisely selecting one of the initially defined six user-selectable positions is no longer possible. Therefore, there is a need for a lever reach adjust mechanism that overcomes these disadvantages.

### Summary of the Invention

[0004] The present invention provides a reach-adjustable lever assembly mountable to a handlebar for actuating one of a gear-change and braking device. The reach-adjustable lever assembly generally includes a support member, a lever and a reach adjust mechanism. The lever is pivotably connected to the support member. The reach adjust mechanism includes a follower, a cam and a cam seat. The follower is fixedly supported on one of the support member and the lever. The cam is rotatably

supported on the other of the support member and the lever and has a plurality of user-selectable positions. The cam seat retains the cam in a current user-selectable position. The lever is pivotably biased toward a rest position to position the cam against the follower. The cam and the follower are configured to provide a different lever rest position for each of the user-selectable positions. The cam seat includes a post supported either on the support member or on the lever and having an engaging portion and a non-engaging portion. The cam is positionable on the post between the engaging and non-engaging portions. The engaging portion retains the cam in the current user-selectable position and the non-engaging portion permits rotation of the cam between the user-selectable positions.

[0005] In one embodiment of the present invention, to prevent rotation between the engaging portion and the cam, the cam includes a non-circular inner surface matingly engageable with a complimentary-shaped non-circular outer surface of the engaging portion. Further, a spring biases the cam toward the engaging portion, while a retaining ring maintains the cam on the post.

[0006] These and other features and advantages of the present invention will be more fully understood from the following description of one or more embodiments of the invention, taken together with the accompanying drawings.

### Brief Description of the Drawings

[0007] In the drawings:

[0008] FIG. 1 is a side view of a bicycle control apparatus including a shift lever assembly having a reach adjust mechanism according to one embodiment of the present invention with a housing partially cut away and showing two rest positions of the shift lever relative to a handlebar;

[0009] FIG. 2 is a cross-sectional view of the shift lever assembly of FIG. 1;

[0010] FIG. 3a and 3b are side views of a shift lever and the reach adjust mechanism of FIG. 1 showing two rest positions of the shift lever;

[0011] FIG. 4 is a cross-sectional view of the shift lever of FIG. 1 showing a cam rotatably supported by a cam seat supported on the lever;

[0012] FIG. 5 is a cross-sectional view of the cam engaged with an engaging portion of a post of the reach adjust mechanism taken along line 5-5 of FIG. 4;

[0013] FIG. 6 is a cross-sectional view of the cam engaged with a non-engaging portion of the post of the reach adjust mechanism taken along line 6-6 of FIG. 4; and

[0014] FIG. 7a and 7b are side views of a shift lever having a reach adjust mechanism according to another embodiment of the present invention showing two rest positions of the shift lever.

## Detailed Description

**[0015]** FIGS. 1 and 2 illustrate a bicycle control apparatus 10 including a brake lever assembly 12 and a shift lever assembly 14. The shift lever assembly 14 includes a reach adjust mechanism 16 according to one embodiment of the present invention. Alternatively, the brake lever assembly 12 may also be configured to include the reach adjust mechanism 16. In this embodiment, the brake lever assembly 12 is integrated with the shift lever assembly 14. Alternatively, the brake lever assembly 12 may be separate from the shift lever assembly 14. The bicycle control apparatus 10 includes a housing 18 that is mountable to a handlebar 20, typically a drop-style handlebar found on a road bike, by a clamp 22. The brake lever assembly 12 includes a brake lever 24 pivotable about a shaft or pivot axis 26 and biased toward a rest position by a preloaded return spring. The brake lever 24 includes a finger grip 28 and a cable seat 30 for receiving one end of a brake cable 32. The other end of the brake cable 32 is connected to a brake device (not shown). The brake lever 24 is pivotable toward the handlebar 20, pulling the brake cable 32 to slow the bicycle.

**[0016]** The shift lever assembly 14 generally includes a shifter lever 34, the reach adjust mechanism 16 and a cable spool 36 for pulling and releasing a control cable 38 connected to a gear change mechanism (not shown) to shift between various gear positions. The gear change mechanism may be a derailleur or other external or internal gear change devices. The shift lever 34 is biased toward a rest position by a preloaded shift lever return spring 40 and preferably tucked behind the brake lever 24. The shift lever 34 includes a first portion 42 rotatably mounted to a shaft or first axis 44, and a second portion 46 preferably paddle-shaped for easy reach by the rider's fingers. The first portion 42 is operatively connected to the cable spool 36 to rotate the spool 36 to shift between gear positions. The second portion 46 of the shift lever 34 is configured to rotate about the shaft 44 along with the first portion 42, the first portion 42 functioning as a support member for the second portion 46. Separately, the second portion rotates about a lever shaft or second axis 48 mounted to the first portion 44 of the shift lever 34. The second axis 48 may lie in a plane substantially perpendicular to the first axis 44. Alternatively, the second axis need not lie in a plane substantially perpendicular to the first axis, for example, it may be parallel to the brake axis 26. The second portion 46 of the shift lever 34 is biased by a preloaded return spring 50 mounted coaxially with the lever shaft 48. In this embodiment, second portion 46 of the shift lever 34 moves with the brake lever 24 when the brake lever 24 is pivoted toward the handlebar 20. Further, the second portion 46 of the shift lever 34 is pivotable toward the handlebar 20 independently of the brake lever 24.

**[0017]** The cable spool 36 is rotatably mounted on the shaft 44 and includes a groove 52 along its periphery, for receiving the control cable 38. The cable spool 36 is

biased in the cable-release direction by tension in the control cable 38 and, preferably, by a cable spool return spring 54. The cable spool return spring 54 is disposed between the cable spool 38 and the housing 18.

**[0018]** Looking to FIGS. 3a, 3b and 4, the reach adjust mechanism 16 includes a follower 56, a cam 58 and a cam seat 60 for maintaining the cam 58 in a current user-selectable position. The follower 56, in this embodiment a bracket, is fixedly supported on the first portion 42 of the shift lever 34 at one end, and engages the cam 58 at the other end. The cam 58 has a variable diameter, a different diameter corresponding to each of the user-selectable position. The cam 58 is rotatable to change the user-selectable position of the cam 58, resulting in a different rest position of the shift lever 34 for each user-selectable position.

**[0019]** The cam seat 60 further includes a post 62 that is connected to the shift lever 34. The post 62 includes an engaging portion 61 and a non-engaging portion 63 (see FIGS. 5 and 6). The cam includes a bore for receiving the post 62 therethrough. The cam 58 is user-positionable on the post 62 between the engaging and non-engaging portions 61, 63. The engaging portion 61 maintains the cam 58 in a current user-selectable position and the non-engaging portion 63 permits the rotation of the cam 58 between the user-selectable positions. To prevent rotation between the engaging portion 61 of the post 62 and the cam 58, the engaging portion 61 has a hexagonal outer surface 64 engageable with a mating inner hexagonal surface 66 on the cam 58 (see FIG. 5). Alternatively, the engaging portion 61 and cam 58 may have any non-circular shape that prevents the cam 58 from rotating but allows axial movement of the cam 58 along the post 62. A spring 68, in this embodiment a compression spring, biases the cam 58 toward the engaging portion 61 of the post 62. A retaining ring 69 retains the cam 58 on the post 62.

**[0020]** In this embodiment, the user may adjust the distance between the shift lever 34 and the handlebar 20 by first positioning the cam 58 at the non-engaging portion 63 of the post 62. The user then rotates the cam 58 to a next user-selectable position to position the shift lever 34 closer or further away from the handlebar 20. Counterclockwise rotation of the cam 58 incrementally positions the shift lever 34 closer to the handlebar 20 until the largest cam diameter is reached; further counterclockwise rotation of the cam 58 then drops the shift lever 34 to its farthest position from the handlebar 20. In FIG. 1, the dashed lines show the shift lever 34 in a reduced-reach rest position, a distance A from the handlebar 20. The solid lines show the shift lever 34 in an extended-reach rest position, a distance B from the handlebar 20. FIGS. 3a and 3b also show the shift lever 34 in two rest positions.

**[0021]** FIGS. 7a and 7b illustrates another embodiment of a reach adjust mechanism 70 for the shift lever 34, similar to the reach adjust mechanism 16 shown in FIG. 1-6, except that a follower 72 is fixedly supported

on the shift lever 34 and a cam 74 is rotatably supported on the support member, in this embodiment the first portion 42 of the shift lever 34. The cam seat 76 is supported on the first portion 42 of the shift lever 34. The cam 74 has a variable diameter, a different diameter corresponding to each of the user-selectable position. The cam 74 is rotatable to change the user-selectable position of the cam 74, resulting in a different rest position of the shift lever 34 for each user-selectable position. FIGS. 7a and 7b show the shift lever 34 in two rest positions.

**[0022]** While this invention has been described by reference to one or more preferred embodiments, it should be understood that numerous changes could be made within the scope of the inventive concepts described. Accordingly, it is intended that the invention not be limited to the disclosed embodiments, but that it have the full scope permitted by the following claims.

## Claims

1. A reach-adjustable lever assembly (14) mountable to a handlebar (20) for actuating one of a gear-change and braking device, the reach-adjustable lever assembly (14) comprising:

a support member (42);  
a lever (34) pivotably connected to the support member (42); and  
a reach adjust mechanism (16; 70) including:

a follower (56; 72) fixedly supported on one of the support member (42) and the lever (34);  
a cam (58; 74) rotatably supported on the other of the support member (42) and the lever (34), the cam (58; 74) having a plurality user-selectable positions; and  
a cam seat (60; 76) for retaining the cam (58; 74) in a current user-selectable position,

the lever (34) rotatably biased toward a rest position to position the cam (58; 74) against the follower (56; 72), the cam (58; 74) and the follower (56; 72) configured to provide a different rest position of the lever (34) for each of the user-selectable positions,

### characterized in that

the cam seat (60; 76) includes a post (62) supported either on the support member (42) or on the lever (34) and having an engaging portion (61) and a non-engaging portion (63), wherein the cam (58; 74) is positionable on the post (62) between the engaging and non-engaging portions (61, 63), wherein the engaging portion (61) retains the cam (58; 74) in the current user-selectable position, wherein the non-

engaging portion (63) permits rotation of the cam (58; 74) between the user-selectable positions, and wherein the cam (58; 74) is biased toward the engaging portion (61).

2. A reach-adjustable lever assembly (14) according to claim 1, wherein the follower (56) is fixedly supported on the support member (42) and the cam (58) is rotatably supported on the lever (34).
3. A reach-adjustable lever assembly (14) according to claim 2, wherein the cam (58) includes a non-circular inner surface (66) matingly engageable with a complimentary-shaped non-circular outer surface (64) of the engaging portion (61) of the post (62) to prevent relative rotation between the cam (58) and the post (62).
4. A reach-adjustable lever assembly (14) according to claim 3, wherein a spring (68) biases the cam (58) toward the engaging portion (61) of the post (62).
5. A reach-adjustable lever assembly (14) according to claim 4, wherein a retaining ring (69) retains the cam (58) on the post (62).
6. A reach-adjustable lever assembly (14) according to claim 1, wherein the follower (72) is fixedly supported on the lever (34) and the cam (74) is rotatably supported on the support member (42).
7. A reach-adjustable lever assembly (14) according to claim 6, wherein the cam (74) includes a non-circular inner surface matingly engageable with a complimentary-shaped non-circular outer surface of the engaging portion of the post to prevent relative rotation between the cam (74) and the post.
8. A reach-adjustable lever assembly (14) according to claim 7, wherein a spring biases the cam (74) toward the engaging portion of the post.
9. A reach-adjustable lever assembly (14) according to claim 8, wherein a retaining ring retains the cam (74) on the post.

## Patentansprüche

1. An einem Fahrradlenker (20) montierbare Hebelanordnung (14) mit einstellbarer Griffweite zum Betätigen einer Gangschaltungs- oder Bremseneinrichtung, umfassend:
- ein Halteelement (42);  
einen drehbar an dem Halteelement (42) befestigten Hebel (34); und  
einen Griffweiteneinstellmechanismus (16; 70),

der

einen fest an einem von Halteelement (42) oder Hebel (34) befestigten Folger (56; 72); einen drehbar an dem anderen von Halteelement (42) oder Hebel (34) gelagerten Nocken (58; 74), der eine Vielzahl von seitens eines Benutzers wählbaren Positionen aufweist; und einen Nockensitz (60; 76) zum Halten des Nockens (58; 74) in einer aktuell vom Benutzer zu wählenden Position aufweist,

wobei der Hebel (34) drehbar in Richtung einer Ruhelage vorgespannt ist, um den Nocken (58; 74) mit dem Folger (56; 72) in Anlage zu bringen, und wobei der Nocken (58; 74) und der Folger (56; 72) dazu ausgebildet sind, für jede der seitens des Benutzers wählbaren Positionen eine andere Ruhelage des Hebels (34) bereitzustellen,

**dadurch gekennzeichnet, dass**

der Nockensitz (60; 76) einen Stift (62) aufweist, der entweder an dem Halteelement (42) oder an dem Hebel (34) gelagert ist, und der einen Angriffsabschnitt (61) und einen Nicht-Angriffsabschnitt (63) aufweist, wobei der Nocken (58; 74) an dem Stift (62) zwischen dem Angriffsabschnitt (61), der den Nocken (58; 74) in der aktuell vom Benutzer zu wählenden Position hält, und dem Nicht-Angriffsabschnitt (63) positionierbar ist, der eine Drehung des Nockens (58; 74) zwischen den seitens des Benutzers wählbaren Positionen gestattet, und wobei der Nocken (58; 74) in Richtung des Angriffsabschnitts (61) vorgespannt ist.

2. Hebelanordnung (14) mit einstellbarer Griffweite nach Anspruch 1, wobei der Folger (56) fest an dem Halteelement (42) gelagert ist und der Nocken (58) drehbar an dem Hebel (34) gelagert ist.
3. Hebelanordnung (14) mit einstellbarer Griffweite nach Anspruch 2, wobei der Nocken (58) eine nicht kreisförmige Innenfläche (66) aufweist, die mit einer komplementär geformten, nicht kreisförmigen Außenfläche (64) des Angriffsabschnitts (61) des Stifts (62) passend in Eingriff bringbar ist, um eine relative Drehung zwischen dem Nocken (58) und dem Stift (62) zu verhindern.
4. Hebelanordnung (14) mit einstellbarer Griffweite nach Anspruch 3, wobei eine Feder (68) den Nocken (58) in Richtung des Angriffsabschnitts (61) des Stifts (62) vorspannt.
5. Hebelanordnung (14) mit einstellbarer Griffweite nach Anspruch 4,

wobei ein Sicherungsring (69) den Nocken (58) an dem Stift (62) hält.

- 5 6. Hebelanordnung (14) mit einstellbarer Griffweite nach Anspruch 1, wobei der Folger (72) fest an dem Hebel (34) gelagert ist und der Nocken (74) drehbar an dem Halteelement (42) gelagert ist.
- 10 7. Hebelanordnung (14) mit einstellbarer Griffweite nach Anspruch 6, wobei der Nocken (74) eine nicht kreisförmige Innenfläche aufweist, die mit einer komplementär geformten, nicht kreisförmigen Außenfläche des Angriffsabschnitts des Stifts passend in Eingriff bringbar ist, um eine relative Drehung zwischen dem Nocken (74) und dem Stift zu verhindern.
- 15 8. Hebelanordnung (14) mit einstellbarer Griffweite nach Anspruch 7, wobei eine Feder den Nocken (74) in Richtung des Angriffsabschnitts des Stifts vorspannt.
- 20 9. Hebelanordnung (14) mit einstellbarer Griffweite nach Anspruch 8, wobei ein Sicherungsring den Nocken (74) an dem Stift hält.

30 **Revendications**

- 35 1. Ensemble de levier réglable en distance (14) pouvant être monté sur un guidon (20) pour actionner l'un d'un dispositif de changement de vitesse et de freinage, l'ensemble de levier réglable en distance (14) comprenant :

un élément support (42) ;  
un levier (34) connecté en pivotement à l'élément support (42) ; et  
un mécanisme de réglage de distance (16 ; 70) incluant :

un poussoir (56 ; 72) supporté de façon fixe sur l'un de l'élément support (42) et du levier (34) ;  
une came (58 ; 74) supportée de façon rotative sur l'autre de l'élément support (42) et du levier (34), la came (58 ; 74) ayant une pluralité de positions sélectionnables par l'utilisateur ; et  
un siège de came (60 ; 76) pour maintenir la came (58 ; 74) dans une position sélectionnable par l'utilisateur actuelle,

le levier (34) poussé en rotation vers une position de repos pour positionner la came (58 ; 74) contre le poussoir (56 ; 72), la came (58 ; 74) et

le poussoir (56 ; 72) configurés pour donner une position de repos différente au levier (34) pour chacune des positions sélectionnables par l'utilisateur,

**caractérisé en ce que**

le siège de came (60 ; 76) inclut un montant (62) supporté soit sur l'élément support (42), soit sur le levier (34) et ayant une partie d'engagement (61) et une partie de non engagement (63), dans lequel la came (58 ; 74) est positionnable sur le montant (62) entre les parties d'engagement et de non engagement (61, 63), dans lequel la partie d'engagement (61) maintient la came (58 ; 74) dans la position sélectionnable par l'utilisateur actuelle, dans lequel la partie de non engagement (63) permet la rotation de la came (58 ; 74) entre les positions sélectionnables par l'utilisateur, et dans lequel la came (58 ; 74) est poussée vers la partie d'engagement (61).

2. Ensemble de levier réglable en distance (14) selon la revendication 1, dans lequel le poussoir (56) est supporté de façon fixe sur l'élément support (42) et la came (58) est supportée de façon rotative sur le levier (34).

3. Ensemble de levier réglable en distance (14) selon la revendication 2, dans lequel la came (58) inclut une surface intérieure non circulaire (66) engageable en ajustement avec une surface extérieure non circulaire (64) de forme complémentaire de la partie d'engagement (61) du montant (62) pour empêcher une rotation relative entre la came (58) et le montant (62).

4. Ensemble de levier réglable en distance (14) selon la revendication 3, dans lequel un ressort (68) pousse la came (58) vers la partie d'engagement (61) du montant (62).

5. Ensemble de levier réglable en distance (14) selon la revendication 4, dans lequel une bague de retenue (69) maintient la came (58) sur le montant (62).

6. Ensemble de levier réglable en distance (14) selon la revendication 1, dans lequel le poussoir (72) est supporté de façon fixe sur le levier (34) et la came (74) est supportée de façon rotative sur l'élément support (42).

7. Ensemble de levier réglable en distance (14) selon la revendication 6, dans lequel la came (74) inclut une surface intérieure non circulaire engageable en ajustement avec une surface extérieure non circulaire de forme complémentaire de la partie d'engagement du montant pour empêcher une rotation relative entre la came (74) et le montant.

8. Ensemble de levier réglable en distance (14) selon la revendication 7, dans lequel un ressort pousse la came (74) vers la partie d'engagement du montant.

9. Ensemble de levier réglable en distance (14) selon la revendication 8, dans lequel une bague de retenue maintient la came (74) sur le montant.

10

15

20

25

30

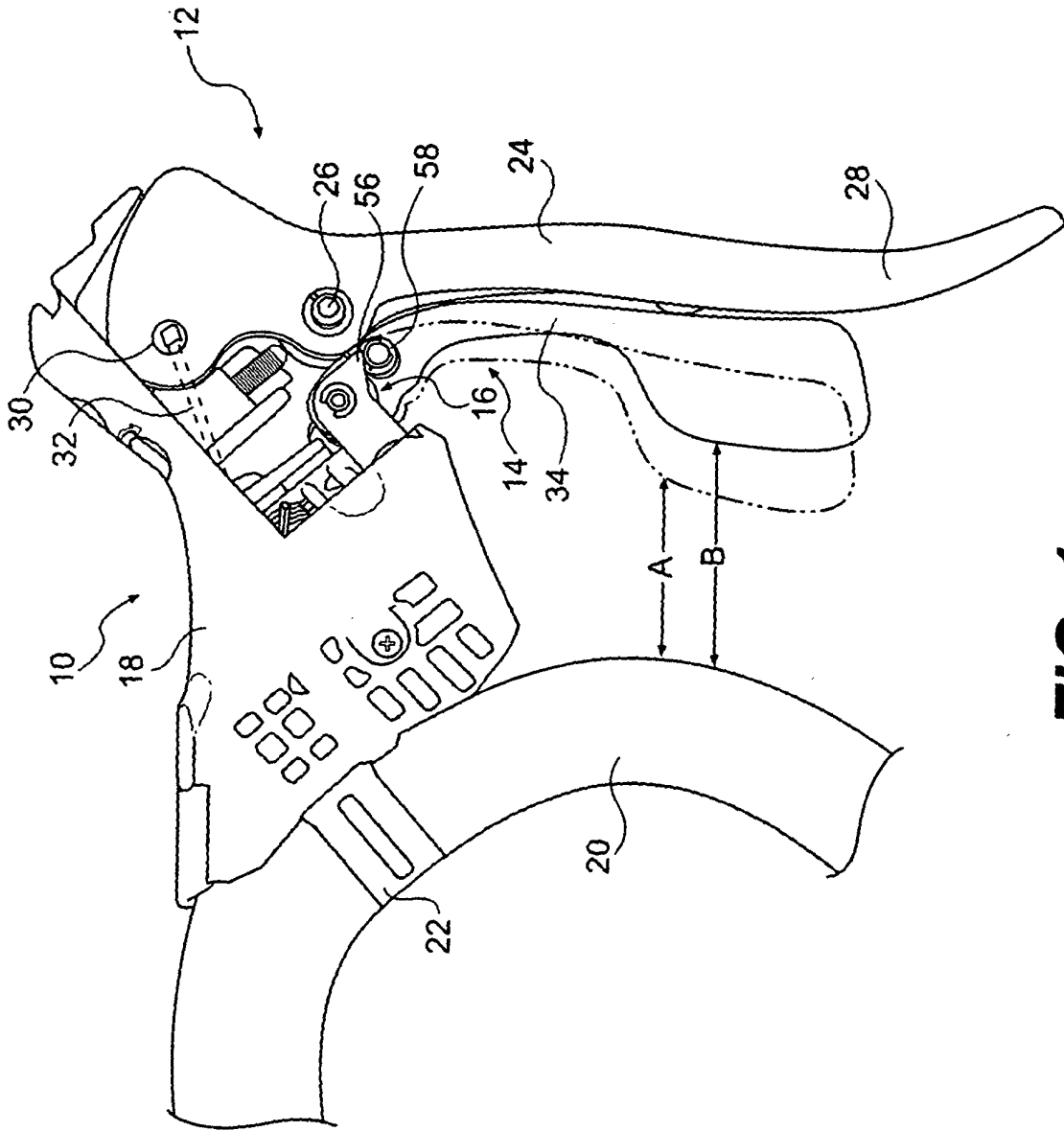
35

40

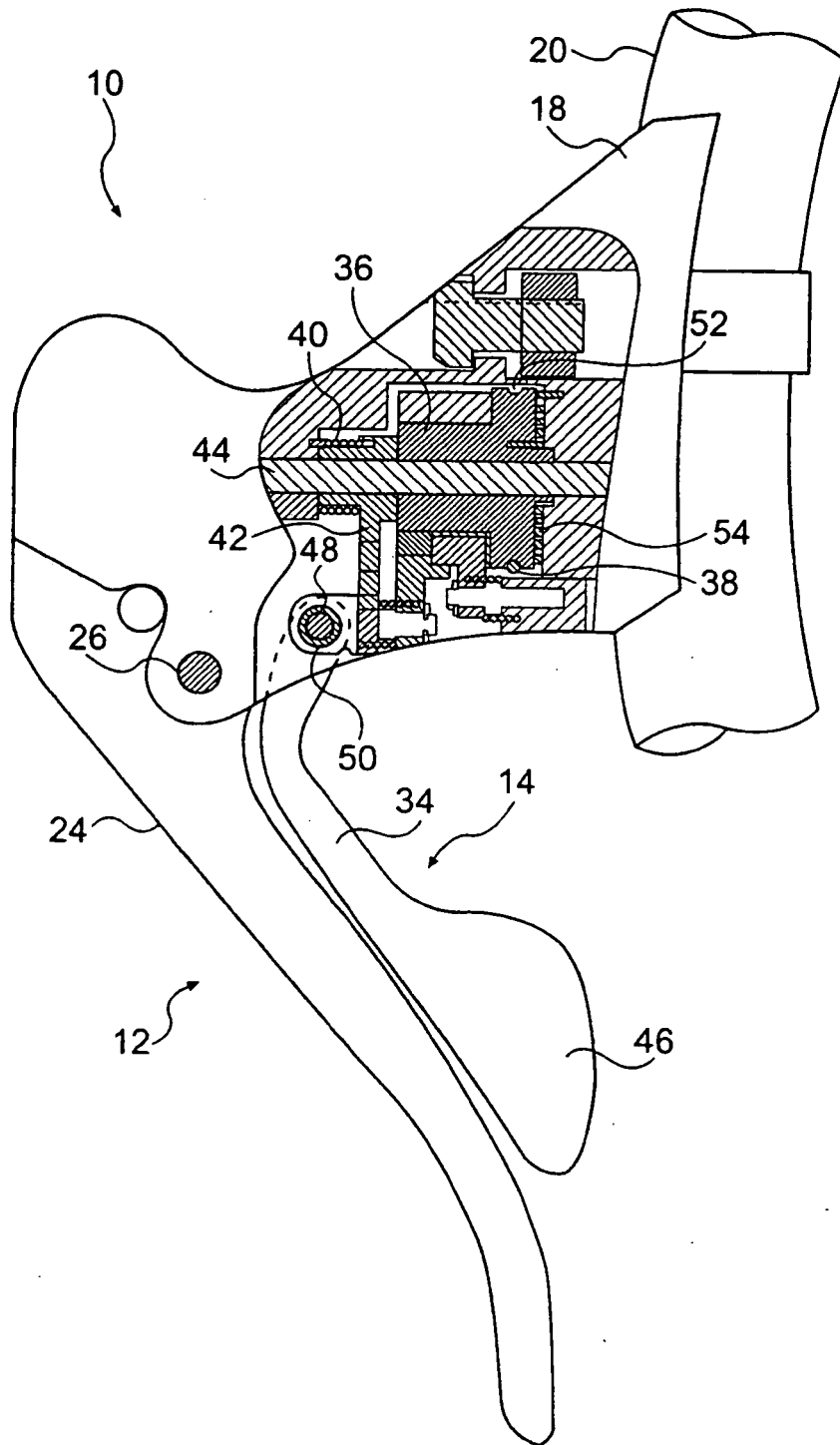
45

50

55

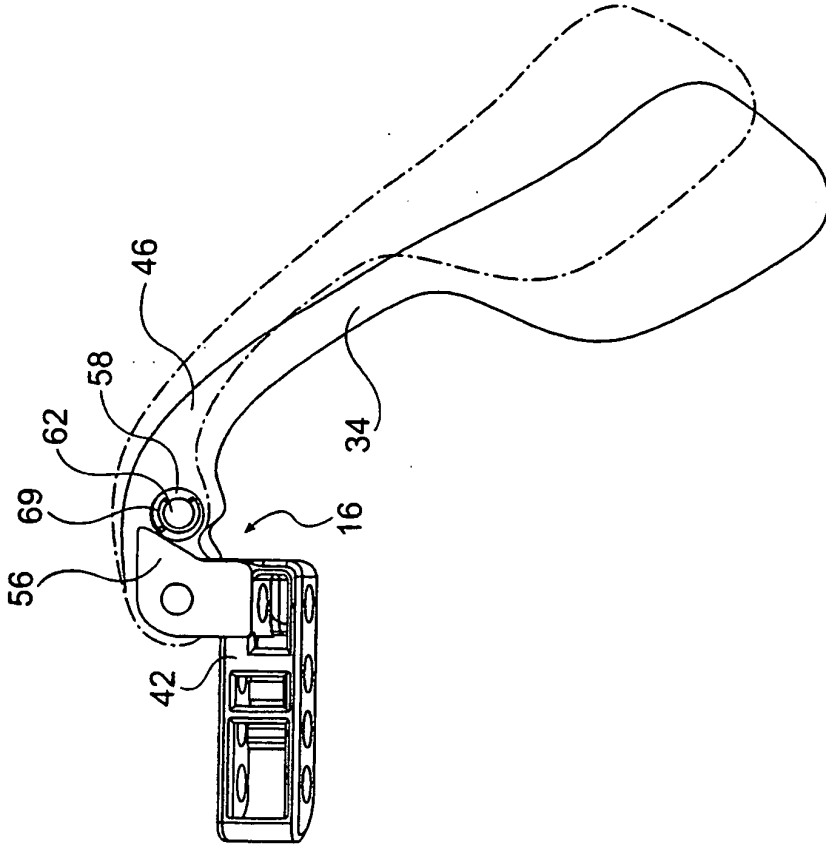


**FIG. 1**

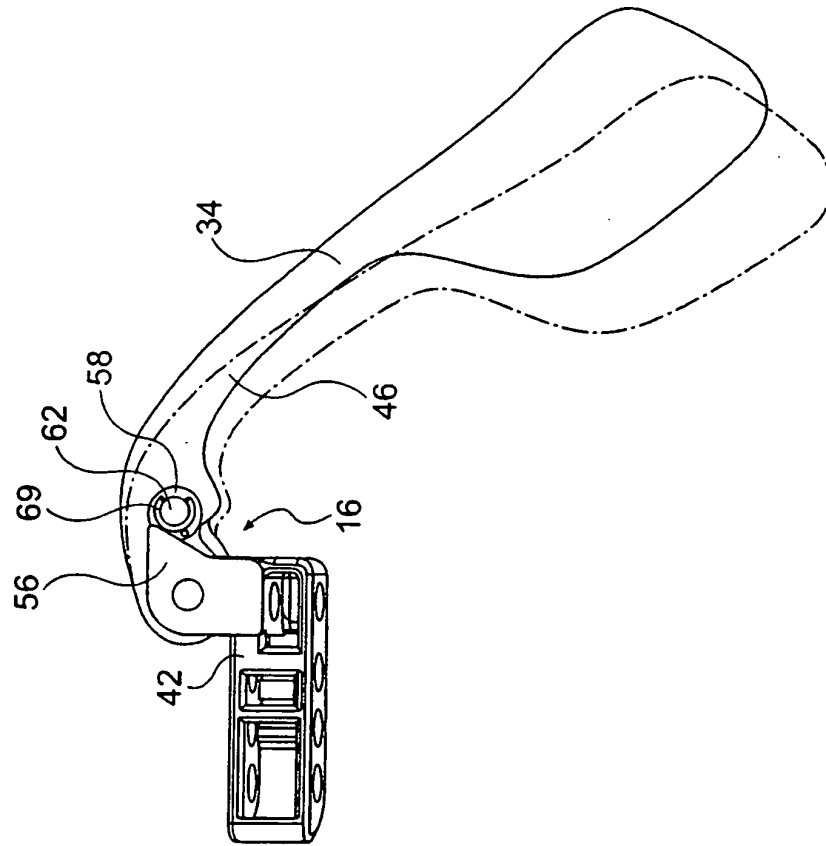


**FIG. 2**

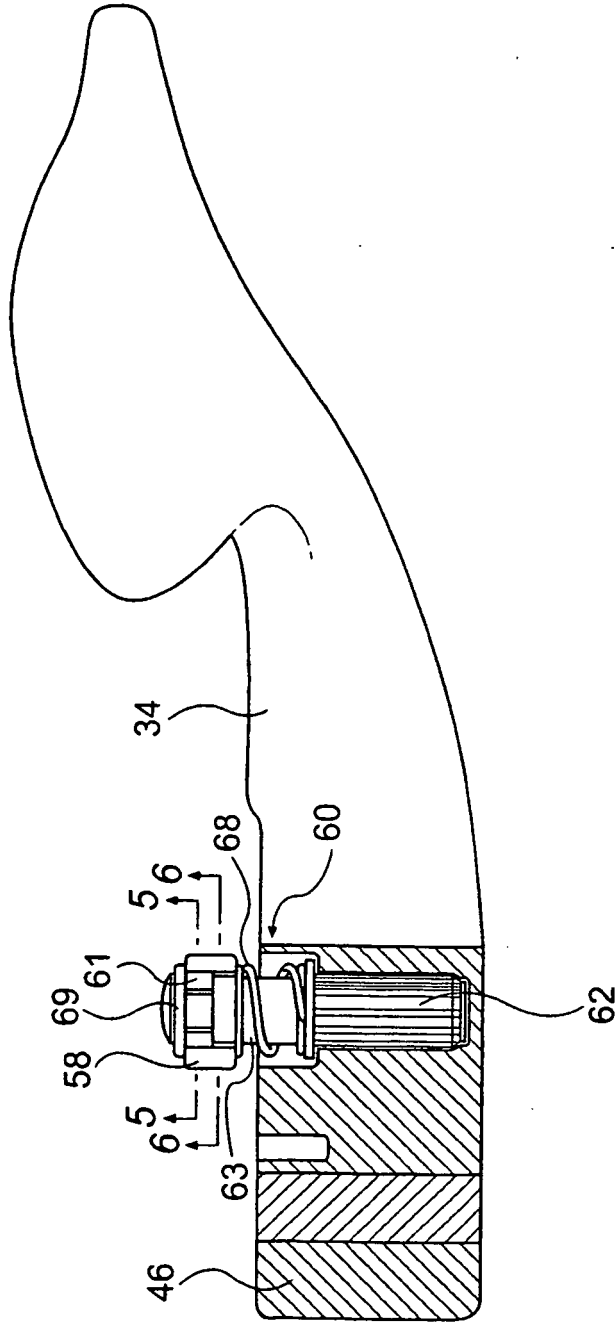


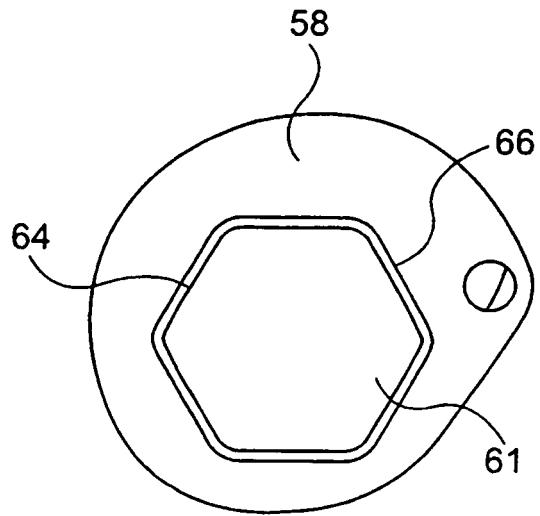


**FIG. 3a**

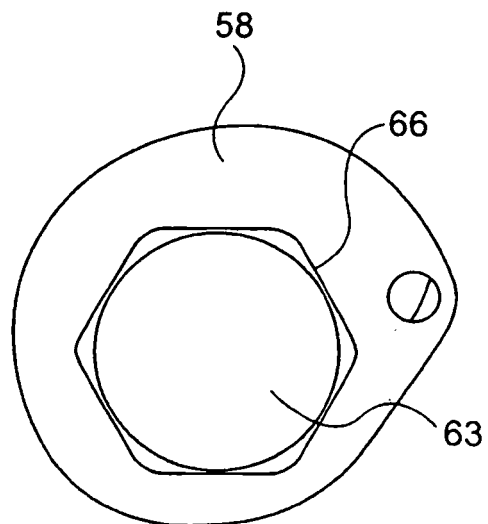


**FIG. 3b**

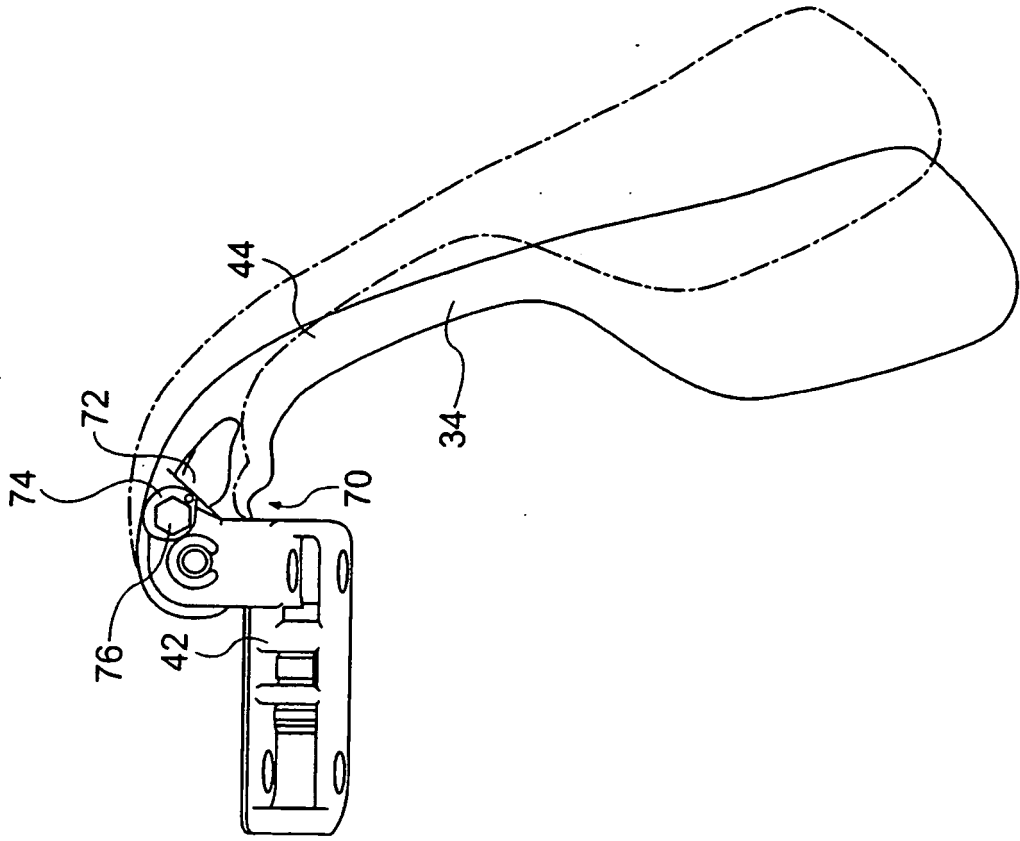




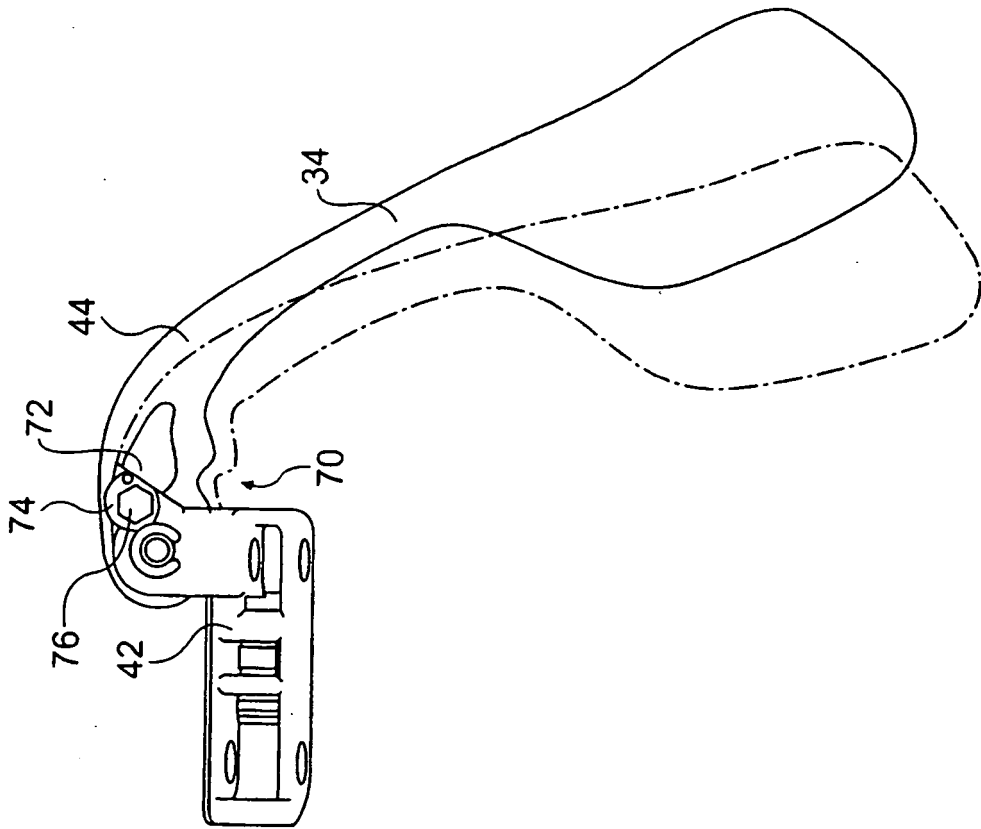
**FIG. 5**



**FIG. 6**



**FIG. 7a**



**FIG. 7b**

**REFERENCES CITED IN THE DESCRIPTION**

*This list of references cited by the applicant is for the reader's convenience only. It does not form part of the European patent document. Even though great care has been taken in compiling the references, errors or omissions cannot be excluded and the EPO disclaims all liability in this regard.*

**Patent documents cited in the description**

- JP 10129293 A [0003]