

No. 756,775.

PATENTED APR. 5, 1904.

W. P. BRETT.

WINDMILL PITMAN AND MEANS FOR ITS AUTOMATIC LUBRICATION.

APPLICATION FILED FEB. 13, 1902.

NO MODEL.

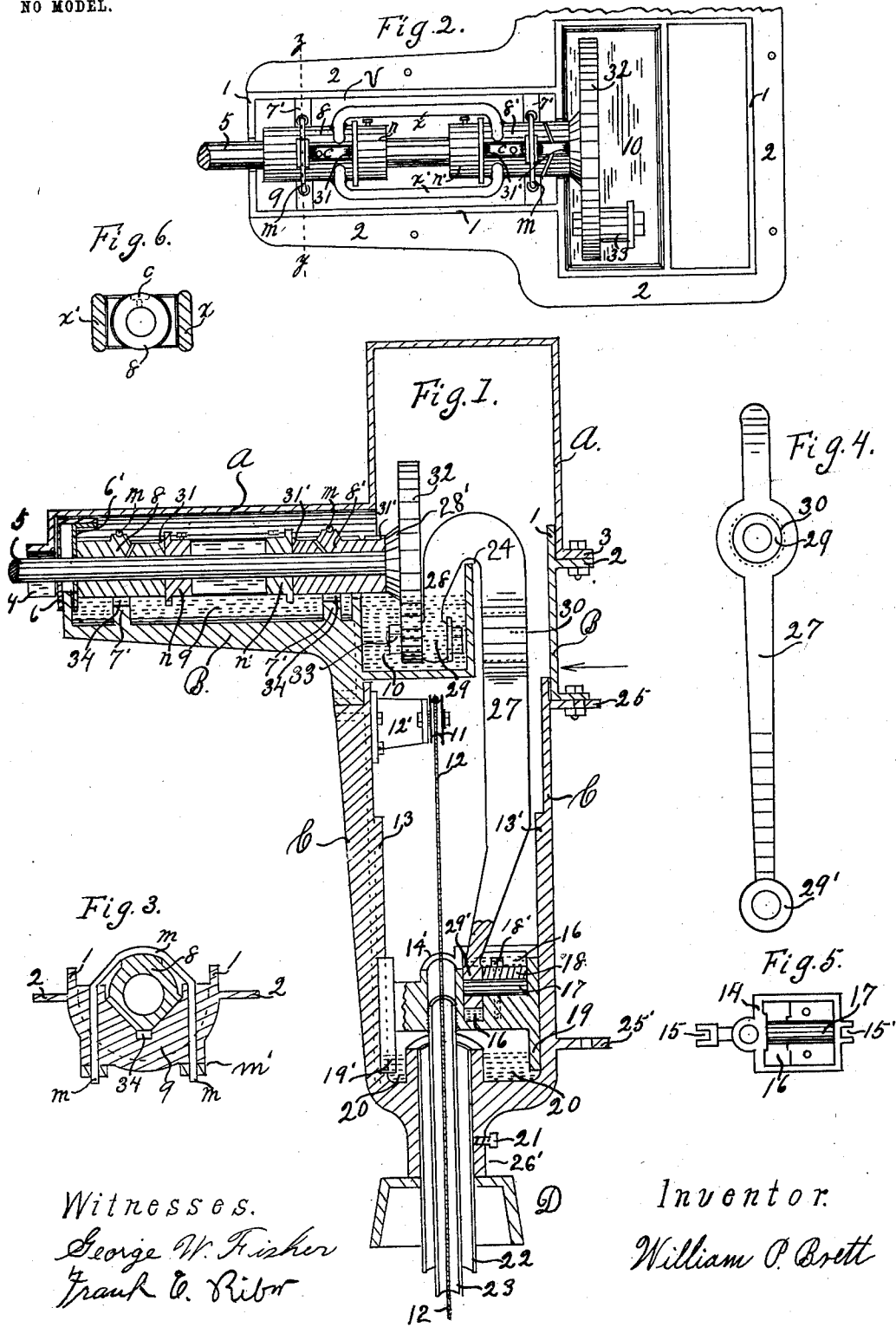

Witnesses.
 George W. Fisher
 Frank C. Ribor

Inventor
 William P. Brett

UNITED STATES PATENT OFFICE.

WILLIAM P. BRETT, OF DECATUR, ILLINOIS.

WINDMILL-PITMAN AND MEANS FOR ITS AUTOMATIC LUBRICATION.

SPECIFICATION forming part of Letters Patent No. 756,775, dated April 5, 1904.

Application filed February 13, 1902. Serial No. 93,910. (No model.)

To all whom it may concern:

Be it known that I, WILLIAM P. BRETT, a citizen of the United States, residing at Decatur, in the county of Macon and State of Illinois, have invented a new and useful Windmill, of which the following is a specification.

My invention relates to that class of windmills known as the "upright" or "vertical" wheel windmill; and the objects of my invention are, first, to provide a windmill-head in compact form in which all of the bearings of the power-transmitting parts mounted therein are automatically lubricated during the operation of the windmill; second, to provide an incasement or protecting inclosure for said bearings and the reservoirs from which they are lubricated, which in itself constitutes the main frame of the windmill-head; third, to produce a windmill in which the separate parts may be cheaply manufactured in convenient interchangeable form, and, fourth, to provide a windmill that is extra strong and durable and in which the different parts are in form to facilitate their assemblage. I attain these objects by the mechanism illustrated in the accompanying drawings, in which—

Figure 1 is a substantially central vertical section through the windmill-head in line with the wheel-shaft. Fig. 2 is a top view of a part of the windmill-head as seen when the cover portion A is removed. Fig. 3 is a vertical section through Fig. 2 on line $z y$. Fig. 4 is a view of the pitman as seen when looking in the direction indicated by the arrow in Fig. 1. Fig. 5 is a top view of the cross-head 14 with the cap 18 removed; and Fig. 6 is a vertical section through the connecting-bars x and x' of the wheel-shaft bearings on line $v w$, Fig. 2.

Similar letters and figures refer to similar parts throughout the several views.

The incasement comprising the three sections A, B, and C constitutes the main frame or turn-table of the windmill and is provided with the vertically-apertured pivot portion 26 and 26' at its lower part, which is adapted to be rotatably mounted upon the tower-cap D as the supporting-bearing for the turn-table. It is preferable to have this pivot portion encompass and be rigidly secured to the upper part of a tubular shaft, as 22, which is adapted

to pass through and rotate in the tower-cap D with its lower end rotatably secured at a lower position within the tower. The upwardly-projecting annular part 26, in connection with the adjacent portion of the incasement-section C, constitutes the oil-reservoir 20 in the lower part of the incasement or windmill-head, into which the downwardly-projecting parts of the cross-head slides 19 and 19' are adapted to project and contact with the lubricant contained therein when the cross-head is at the lower limit of its stroke. The intermediate section of the main frame or incasement portion of the windmill-head B is provided with a lateral extension having an oil-reservoir, as 9, and suitable supports therein, as 7', for the wheel-shaft bearings and adjacent to and extending some distance below said lateral extension another oil-reservoir 10, which opens upwardly within the main or body portion of the incasement and having the inner wall 24 stand in a position so as to leave an open space within the incasement which extends from the bottom to the top thereof. The upper section A of the incasement is simply a cap or cover made to conform in size and shape to the section next below and is provided with the laterally-extending flange 3, which is adapted to be firmly bolted to the flange 2 of section B. Each section is made to telescope or fit over an upwardly-projecting portion of the section next below and to rest upon and be rigidly secured to a laterally-projecting flange thereof, thus making water and dust proof joints between the sections. The pitman 27 is arranged to operate with its main or body part in the open space within the incasement outside of the wall 24 of reservoir 10, the wall 24 occupying a position between the body part of the pitman and the lower part of the crank-disk, and the space between the crank-disk 32 and the wall 24 is ample to admit the wrist-pin 33 and pitman-bearing 29 in connection therewith when the pitman stands at the lower limit of its stroke, the downwardly-projecting part 28 of the pitman being of such length and at such distance from the body part of the pitman as to operate clear of the wall 24 at all parts of its range of motion.

The cross-head 14 is provided with the slide

portions 19 and 19', having grooves 15 and 15', which are adapted to a slidable engagement with the vertical bars or flanges 13 and 13', which may be either integral parts of section C or separate parts rigidly secured thereto. The cross-head is also provided with the vertical aperture 14', which when the cross-head is mounted, as shown in Fig. 1, stands centrally above the vertical aperture of the tubular shaft 22, and the tubular reciprocating shaft 23 is adapted to be rigidly secured in the aperture 14', preferably threaded and screwed therein, as shown, and extend downwardly centrally through the tubular shaft 22, thus providing a central vertical opening through the pivot portion of the windmill-head for the pull-out cord 12, which is made to extend from the foot of the tower upwardly through said central opening and over the guide-pulley 11 just below the reservoir 10, from which it may in any convenient way be made to extend around other guide sheaves or pulleys and connect to the steering-vane of the windmill in the usual manner for the purpose of throwing the wind-wheel in or out of the wind.

16 (shown in Figs. 1 and 5) is an oil-receptacle carried by the cross-head 14 and is preferably an integral part thereof, and the wrist-pin 17, on which the lower end of the pitman 27 is journaled, is anchored within it at a position below the level of the lubricant, so that this end of the pitman is continuously lubricated thereby. The pitman 27 extends upwardly from the wrist-pin 17 to a position above the wall 24 of reservoir 10, at which position it turns laterally so as to overhang said reservoir and is provided with the dependent or downwardly-projecting part 28, having formed at its lower extremity the wrist-pin or pivot-bearing 29, which is journaled on the wrist-pin 33 of the crank-disk 32.

5 is a crank or wheel shaft journaled in bearings 8 and 8', with a portion of it overhanging reservoir 10 and carrying the crank portion of the windmill in such manner that it is made to contact with the lubricant therein as it rotates, and thereby lubricate the crank wrist-pin and at the same time carry a portion of the lubricant up as it revolves, so that it will flow down upon the incline portion 31'' on the end of the bearing 8', which is made to abut against the hub portion 28' of the crank-disk. The incline 31'' leads to suitable oil ducts or channels, which conduct it partially to the shaft inside of said bearing and partially through oilways on the outside thereof, which lead into the oil-reservoir 9 below said bearing, from which the surplus therefrom flows back into reservoir 10, from which it may be repeatedly used. The bearings 8 and 8' are made rigid with the side bars x and x' , which are preferably integral parts of said bearings and are for the purpose of holding the bearings in perfect alinement. These bearings are held in position

by the bolts m , which are made in a U or staple form and are drawn tight by the nuts m' , as shown in section in Fig. 3. The adjacent ends of the bearings 8 and 8' are faced true with the shaft, and the collars n and n' are machined to a true fit to the shaft and the end faces of the bearings, against which they are carefully adjusted and secured upon the shaft, preferably by set-screws, as shown. It is desirable also to provide these collars with flanges that are larger in diameter than the end portion of the bearing abutting thereagainst, so that as they rotate the lower part contacts with the oil in reservoir 9 and by adhesion carries a quantity of it over with them in such manner that a portion of it will flow down upon the incline 31 and 31', which lead into channels c , which lead to the portion of the shaft within the bearings, thus lubricating the shaft during the operation of the windmill. The bearing 8' may be amply lubricated direct from the crank portion; but as the collar n' is necessary in order to maintain the shaft in position and as it can be made to deliver oil in channel c without extra cost it is preferred to have oil delivered upon both ends of this bearing, so that there is at all times during the operation of the windmill a copious flow of oil onto and through the bearing. The shaft-bearing supports 7' in the reservoir 9 are made to conform to the shape of the bearings as shown in cross-section in Fig. 3, so that when bound firmly therein by the bolts m the bearings are so firmly fixed in rigid and perfect alinement that the shaft 5 is provided with bearings that are as perfect as if it were in bearings babbitted in an integral part of the mill-head. Thus it is readily seen that any of the working parts of the windmill-head that is subject to excessive strain or wear can at any time be easily removed and replaced by a new and like part without having to change any part of the main frame of the windmill-head.

In Fig. 6 is shown an end view of the bearing between the side bars x and x' , which are here shown in section, and in broken lines at the top is outlined a cross-section of the oil-channel c and the oil-hole therein leading to the interior of the bearing.

The pitman 27 is preferably provided with an aperture or opening 30, which extends through the body part opposite to the wrist-pin bearing 29, as shown in Figs. 1 and 4, so that the wrist-pin 33 may be readily inserted or removed. In order to do this, the crank must be turned so that the wrist-pin stands at a position above the top edge of the reservoir-wall 24.

In Fig. 5 the cross-head 14 is shown with the cap or binding plate 18 (see Fig. 1) removed, so as to expose the wrist-pin 17, showing the manner in which it is secured therein by means of the plate 18 and the cap-screws 18', which bind it firmly in place, the wrist-pin being first placed in the pitman-bearing,

then with the pitman end placed in position in the cross-head and secured there, as above described.

What I claim as my invention is—

1. In combination, an incasement constituting the main frame or turn-table of the windmill, a vertically and substantially centrally-apertured pivotal anchorage portion arranged at the lower part of said incasement, an oil-receptacle adjacent to the top end of said anchorage portion, space for the operative mounting of reciprocating mechanism within the lower portion of said incasement, an oil-receptacle arranged at one side within said incasement above the operative range of said reciprocating mechanism, means, above said last-named receptacle, for the operative mounting of a rotatable member, and space at the side of said last-named receptacle within said incasement for the operative range of a pitman that is adapted to be operatively connected at one end to said member and at the other end to said reciprocating part.

2. In combination a vertically-elongated incasement constituting the main frame or turntable of the windmill, a vertically-arranged and substantially centrally-apertured pivotal anchorage portion arranged at the lower part of said incasement, an oil-reservoir surrounding the upper end of said anchorage portion, a reciprocating part operatively mounted within the lower part of said incasement, an oil-receptacle arranged at one side within said incasement above the operative range of said reciprocating part, a rotatable shaft mounted above said receptacle, a wrist-pin anchored eccentrically to said shaft, and a pitman adapted to be operatively journaled on said wrist-pin near its upper end and extend downwardly past said receptacle and be operatively connected to said reciprocating part near its lower end.

3. In combination an incasement constituting the main frame or turn-table of the windmill, an opening through the bottom portion of said incasement, an oil-receptacle arranged within said incasement near the upper portion thereof, a rotatable member mounted mainly above and arranged to operate partially within said receptacle, a reciprocating part arranged to extend operatively through the opening in said bottom portion, a pitman adapted to be eccentrically pivoted near its upper end to said rotatable member and to extend downwardly past said oil-receptacle and impart reciprocating motion to said reciprocating part upon the rotation of said member, and means whereby the bearings of said rotatable member may be automatically lubricated with oil taken from said receptacle during the operation of the windmill.

4. In combination a vertically-elongated incasement constituting the main frame or turntable of the windmill, and provided with a substantially vertical centrally-apertured

pivot portion at the lower part of the incasement, an oil-reservoir within the incasement adjacent to said pivot portion, a rotatable shaft mounted horizontally at the upper portion of said incasement and projecting into the main or body part thereof, another oil-reservoir arranged within said incasement upon the side adjacent to and below said shaft, a crank made rigid with the part of said shaft that is directly above the reservoir, reciprocating power-transmitting mechanism operatively connected to said crank and adapted to extend operatively downwardly within said incasement past said reservoirs and through said centrally-apertured pivot portion, means whereby the bearings of said shaft, crank, and reciprocating mechanism within said incasement are automatically lubricated during the operation of the windmill, and means for automatically returning the surplus lubricant dripping from said bearings into reservoirs where it is available for repeated automatic use.

5. In combination a vertically-elongated incasement constituting the main frame or turntable of the windmill and provided with a substantially vertical centrally-apertured pivot portion at and projecting partially upwardly within the lower portion of the incasement, a rotatable shaft mounted mainly to one side at the upper portion of said incasement and projecting partially into the main or body part thereof, an oil-reservoir arranged within said incasement upon the side adjacent to and below said shaft, a crank made rigid with the part of said shaft that is directly above said reservoir, reciprocating power-transmitting mechanism operatively connected with said crank and adapted to extend operatively downwardly within said incasement past said reservoir and through said vertically-apertured pivot portion, and means whereby the operative bearings of said shaft, crank, and reciprocating mechanism are automatically lubricated during the operation of the windmill.

6. In windmills in combination a vertically-elongated incasement comprising three sections detachably secured together one above the other, a vertically-apertured pivotal anchorage portion, an oil-receptacle adjacent to said portion and rigid guide-bars extending upwardly from said receptacle at the lower part of the lowermost of said sections, and crank and shaft oil-receptacles made integral with the intermediate of said sections.

7. In combination a vertically-elongated incasement constituting the main frame or turntable of the windmill and provided at its lower part with a substantially vertically-apertured pivot portion, an oil-reservoir within said incasement adjacent to the upper part of said pivot portion, vertical guide-bars made rigid with and extending upwardly within said incasement from opposite sides of said oil-reservoir, a vertically-movable element adapted to a sliding engagement with said guide-bars and

adapted to contact with the lubricant in said reservoir upon its reciprocation, a vertical aperture through said element vertically above the vertical aperture of said pivot portion, and

5 a tubular shaft rigidly secured in the aperture of said element and adapted to reciprocate through the aperture of said pivot portion.

8. In windmills, in combination a rotatable member and a reciprocating part, mounted

10 one above the other, a pitman eccentrically pivoted to said member near one end and pivotally connected to said reciprocating part near the other end, a laterally-extending part near the upper end of said pitman having a

15 dependent portion and provided near the extremity of said portion with one of said pivot-bearings, and an oil-receptacle so mounted that said extremity is made to intermittently contact with the lubricant contained therein

20 upon the rotation of said member.

9. In windmills, in combination a vertically-elongated incasement constituting the main frame or turn-table, a rotatable member and a reciprocating part operatively mounted with-

25 in said incasement one above the other, a pitman eccentrically pivoted near one end to said member and pivotally connected, near the other end, in an oil-receptacle carried by said reciprocating part, a downward projection near the upper end of said pitman provided

30 near its extremity with one of said pivot-bearings, and another oil-receptacle so mounted within said incasement that said downward projection is caused to intermittently contact with the lubricant contained therein upon the

35 rotation of said member.

10. In windmills, in combination a vertically-elongated incasement constituting the main frame or turn-table and provided with

40 an oil-receptacle arranged therein upon one side toward its upper portion and another within the bottom portion thereof, a reciprocating part having downwardly-projecting guide portions, and a rotatable member,

45 mounted one above the other and mainly within said incasement, a pitman eccentrically pivoted to said member near one end and pivotally connected to said reciprocating part near the other end, and a downward projection near

50 the upper end of said pitman provided near its extremity with one of said pivot-bearings, whereby said downwardly-projecting portions of said pitman and reciprocating part are adapted to intermittently contact with the lubricant in said receptacles upon the rotation

55 of said member.

11. In windmills, in combination a vertically-elongated incasement constituting the main frame or turn-table and provided with

60 oil-receptacles one arranged within upon one side toward the upper portion and another within the lower portion of said incasement, a reciprocating part, having downwardly-projecting guide portions, and a rotatable member,

65 mounted one above the other and mainly

within said incasement, a pitman eccentrically pivoted to said member near one end and near the other end pivoted within an oil-receptacle carried by said reciprocating part, and a downward projection near the upper end of said pitman provided near its extremity with one of said pivot-bearings, whereby the bearings of said member, pitman, and reciprocating part are adapted to be automatically lubricated during the operation of the windmill, and be protected from the destructive elements of the weather by said incasement.

12. In windmills, in combination a main frame or turn-table provided with a laterally-projecting part, spaced bearings united and made rigid with longitudinal side bars and adapted to be removably secured to said laterally-projecting part, a rotatable shaft journaled in said bearings, an oil-receptacle within said laterally-projecting part below said shaft, and collars arranged upon said shaft abutting against the adjacent ends of said bearings and adapted to rotate with their lower portion in contact with the lubricant in said receptacle whereby a quantity of said lubricant, upon the rotation of said shaft, is elevated and delivered into channels upon said bearings which lead to the shaft-journals therein, substantially as and for the purpose set forth.

13. In windmills, in combination spaced bearings carried by the main frame or turn-table, rigid side bars made integral with and uniting said bearings, a rotatable shaft journaled in said bearings, collars secured upon

10 said shaft and adapted to rotatably abut against the adjacent ends of said bearings, and means whereby said bearings are rigidly and detachably secured to said main frame or turn-table.

14. In windmills, in combination spaced

10 bearings carried by the main frame or turn-table of the windmill, rigid side bars made integral with and uniting said bearings their points of union therewith being upon opposite sides and intermediate the end portions of the bearings, a rotatable shaft journaled in said bearings, collars upon said shaft abutting against the adjacent ends of the bearings, and means whereby said bearings are removably secured to said main frame.

15. In windmills, in combination spaced bearings carried within an incasement portion of the main frame or turn-table, rigid side bars made integral with and uniting said bearings, a rotatable shaft journaled in said bearings, and means within said incasement portion whereby the journals in said bearings are automatically lubricated upon the rotation of said shaft.

16. In windmills, in combination spaced

12 bearings carried by the main frame or turn-table of the windmill, rigid side bars made integral with and uniting said bearings, a rotatable shaft journaled in said bearings, an oil-receptacle below said shaft, oil-elevating disk-

13

surfaces carried by said shaft and arranged to rotate against the adjacent end surfaces of said bearings and contacting at their lower portion with the lubricant contained in said receptacle, and oil-conducting channels beginning with acute edge portions bearing against said disk-surfaces and leading to the portion of the shaft within said bearings.

17. The combination, in the main frame or turn-table of a windmill-head, of a vertically-elongated incasement adapted to inclose the reciprocating mechanism of the said head, a part made integral with the said incasement at its upper portion and adapted to carry a horizontally-arranged rotatable shaft, a vertically-apertured pivot portion constituting the lower part of the said incasement, and an oil-reservoir arranged upon one side within the said incasement and having its lower extremity above the upper part of the said pivot portion.

18. The combination, in the main frame or turn-table of a windmill-head, of a vertically-elongated incasement constituting a protecting-inclosure for the main power-transmitting elements of the reciprocating mechanism of the said head, a shaft-supporting part at the upper portion of the said incasement, a vertically-apertured pivot portion, an oil-storage reservoir so arranged that its bottom portion is below the upper limits of the apertured part of the said pivot portion, another oil-storage reservoir upon one side within the central portion of the said incasement, and a cross-head guide extending from near the bottom upwardly within the said incasement.

19. In a windmill, in combination a vertically-elongated incasement constituting the main frame or turn-table of the windmill-head and a protecting-incasement for the wheel-shaft journals and the main power-transmitting elements of the reciprocating mechanism of the said head, a wheel-shaft-supporting part at the upper portion of the said incasement, a vertically-apertured pivot portion so arranged that the upper end of the said aperture opens into the said incasement, an oil-storage reservoir so arranged that its bottom portion is below the upper limits of the apertured part of the said pivot portion, and cross-head guides extending from said reservoir upwardly within the said incasement.

20. In a windmill, in combination a vertically-elongated incasement constituting the main frame or turn-table of the windmill-head and a protecting-inclosure for the journal and sliding portions of the main power transmitting and lubricating devices carried by the said head, a shaft-supporting part constituting a portion of the upper structure of the said main frame, a vertically-apertured pivot portion made integral with the lower part of the said turn-table, and an oil-storage reservoir opening upwardly within and constituting an integral part of the central portion of the said incasement.

21. In windmills, in combination a vertically-elongated incasement constituting the main frame of the windmill-head, a vertical aperture through the bottom portion of said incasement, an oil-receptacle arranged within the incasement approximately midway between the bottom and top portions thereof, a rotatable shaft mounted above the level of said receptacle, a wrist-pin anchored eccentrically to said shaft, a reciprocating part extending operatively through said vertical aperture, and a pitman adapted to be operatively pivoted, to said wrist-pin, near its upper end and to extend downwardly within said incasement beyond said oil-receptacle and impart reciprocating motion to said reciprocating part upon the rotation of said shaft.

22. In windmills, in combination a rotatable member and a reciprocating part, mounted with said member above said part, an oil-receptacle mainly below said member and above said reciprocating part, and a pitman pivoted near its lower end to said part and provided near its upper end with a downward projection, the extremity of which is eccentrically pivoted to said member and adapted to intermittently contact with the lubricant contained in said receptacle upon the rotation of said member.

23. In windmills, in combination a rotatable member and a reciprocating part, mounted one above the other, a pitman eccentrically pivoted near one end to said member and pivotally connected to said part near the other end, a downward projection near the upper end of said pitman provided near its extremity with one of said pivot-bearings, and an oil-receptacle so mounted that said extremity is adapted to intermittently contact with the lubricant contained therein upon the rotation of said member.

24. In windmills, in combination a rotatable member and a reciprocating part mounted with said member above said part, a pitman eccentrically pivoted to said member near its upper end and pivotally connected near its lower end in an oil-receptacle which is mounted to move in connection with said part, a downward projection near the upper end of said pitman comprising near its extremity said upper pivot-bearing, and another oil-receptacle so mounted that said upper pivot-bearing is adapted to intermittently contact with the lubricant contained therein upon the rotation of said member.

25. In a windmill, in combination a main frame or turn-table, a rigid bracket constituting a part of the said turn-table, spaced bearings rigidly but detachably secured to the said bracket, and rigid side bars made integral with and uniting the said bearings.

WILLIAM P. BRETT.

Witnesses:

S. R. GHER,
FRANK EWING.