

- (21) Application No 8210584
- (22) Date of filing 8 Apr 1982
- (30) Priority data
- (31) 8111420
- (32) 10 Apr 1981
- (33) United Kingdom (GB)
- (43) Application published 20 Oct 1982
- (51) INT CL³
H01H 85/00
- (52) Domestic classification
H2G BB
- (56) Documents cited.
GB 1479243
GB 1449648
GB 1242824
GB 0878533
GB 0336270
- (58) Field of search
H2G
- (71) Applicants
Kenneth E. Beswick
Limited,
Alert Works, Frome,
Somerset BA11 1PP
- (72) Inventor
David Watson
- (74) Agents
Baron and Warren,
18 South End,
Kensington, London
W8 5BU

(54) Electrical fuse

(57) A time delay electrical fuse has a fuse element comprising a conductive wire 5, a spiral spring 7 and a fusible solder connection 6 connecting the wire and spring in series. The fuse element is mounted between two conductive posts 3, 4 with the spring under tension. Surrounding the wire

adjacent the fusible connection 6 is a resistor 8 which is connected in series with the fuse element via the post 3. In addition to its current limiting function, the resistor also serves as a heat source for heating the fusible connection and assisting fusing of the latter upon sustained overload currents, whilst improving the fuse's ability to withstand surge and transient currents.

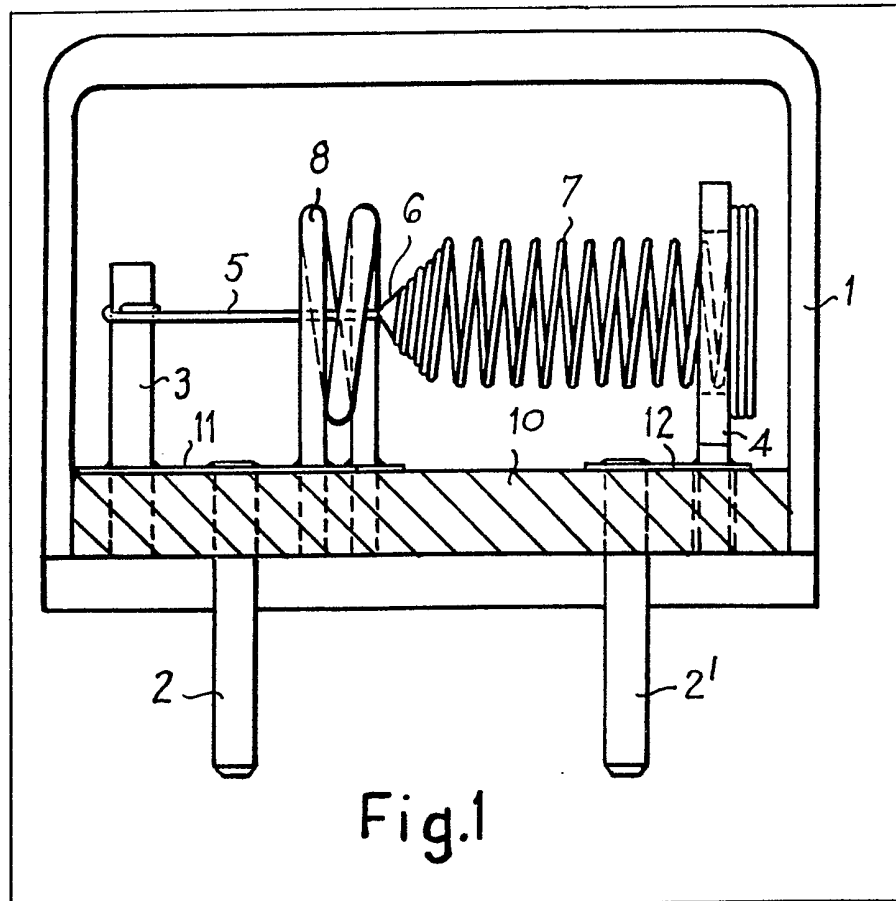

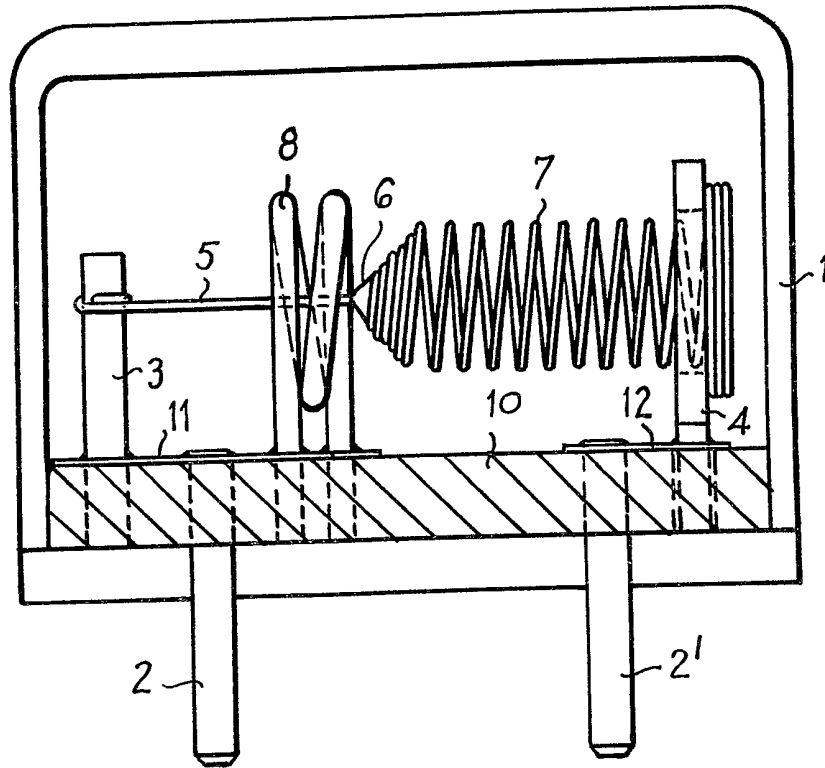

Fig. 1

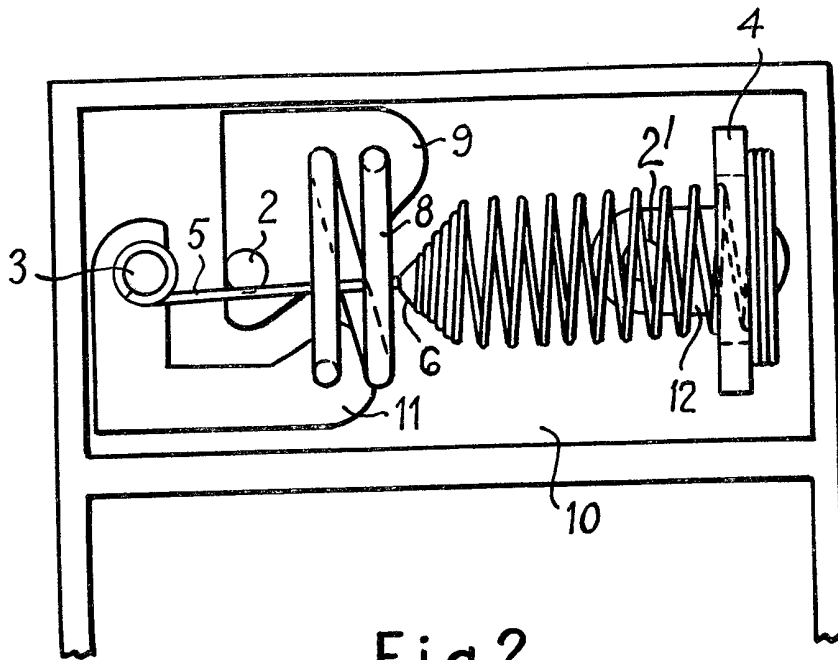

Fig. 2

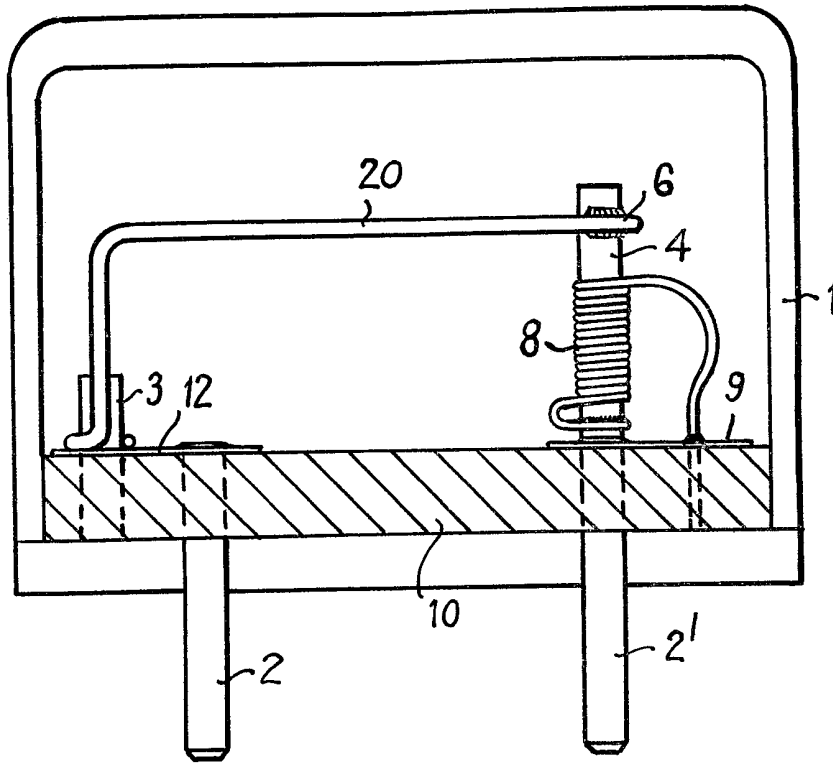

Fig. 3

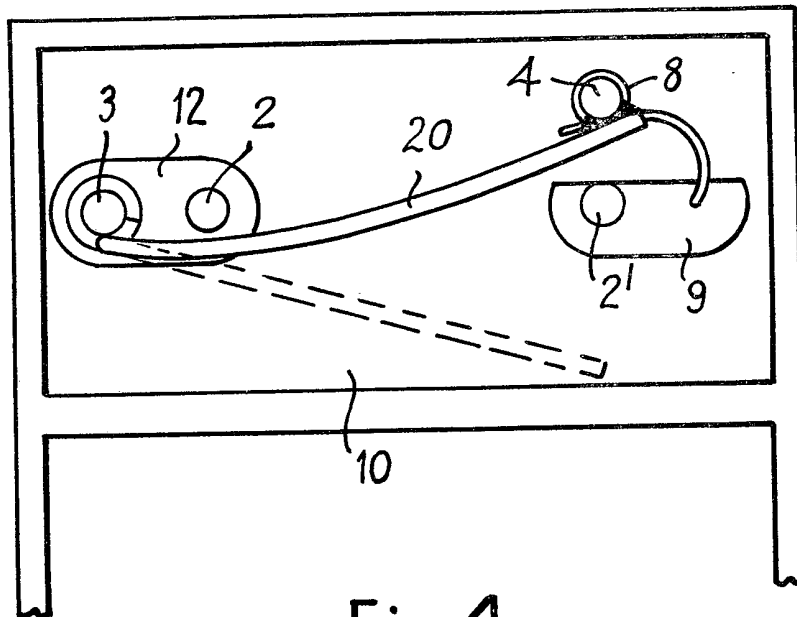

Fig. 4

3/3

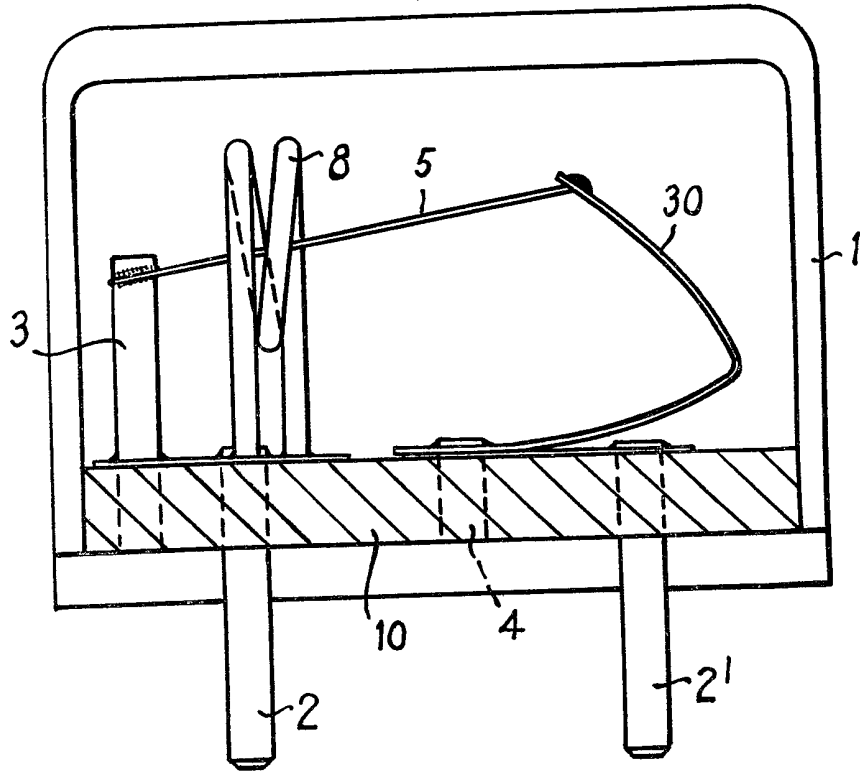

Fig. 5

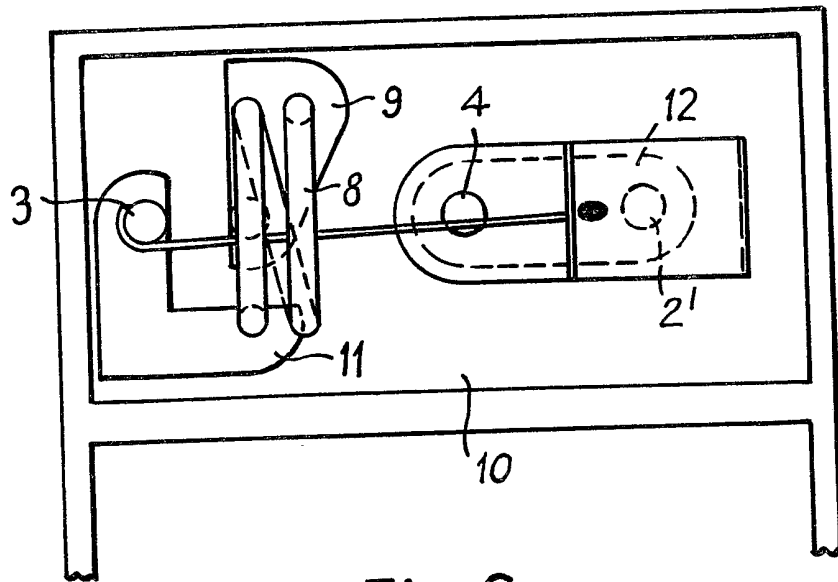

Fig. 6

SPECIFICATION

Electrical fuse

The present invention relates to electrical fuses and, more particularly, to time lag or time delay fuses.

It is known to manufacture miniature time delay cartridge fuses using spring-type or spirally wound fuse elements. With either type of fuse element it is possible to achieve sufficiently long operating periods at ten times rated current to withstand switching surges and transients which occur in many circuits. However, when very high energy electrical pulses occur, both these known constructions will operate unless the circuit is "overfused". An "overfused" circuit is one which incorporates a fuse having a rating very much higher than the rating of the circuit to be protected.

An object of the present invention is to mitigate the need to "overfuse". To this end, the invention consists in a time delay electrical fuse in which a fuse element and a resistor or other electrical circuit component are connected in series and the electrical circuit component serves as a heat source arranged to heat the fuse element.

When the heat source is a resistor, the latter also provides the fuse with a current limiting function. The resistor, which may comprise a resistance wire, such as, a copper-nickel or nickel-chromium wire, spirally wound in a multiplicity of turns about an insulating core, typically, a glass fiber core, may be arranged in one or more turns about the fuse element. Alternatively, the resistor may comprise a resistance wire wound upon a support member which may, in turn, enclose the entire fuse element. Instead of a resistor, any other electrical circuit component which produces heat may be used and be so disposed as to heat and assist in the operation of the fuse element. Such other component may comprise a semi-conducting device, for example, a diode, diac thyristor, transistor or metal oxide varistor.

The resistor or other electrical circuit component is arranged so that convected, radiated and/or conducted heat from the circuit component assists in the operation of the fuse element. This results in a minimum fusing current lower than that which would otherwise be obtained from the fuse element alone. When very high surge or transient overloads occur, the fuse element behaves in exactly the same manner as would a similar fuse element without the series-connected resistor or other circuit component because the operation is so fast that there is insufficient time for the circuit component to respond. In order to achieve such an overload, however, sufficient voltage must exist to over-ride the current limiting effect of any resistance.

The fuse element may comprise a spring member secured in a stressed position by a fusible link or connection. Alternatively, it may comprise a thin fuse wire spirally wound in a multiplicity of turns about an insulating core. The end sections of the fuse wire winding may be shorted out to leave

only a minimum of active, fusible turns at its centre or a similarly wound fuse element may have an eutectic blob affixed to the central active turns.

Conveniently, the fuse is mounted in an insulating flame retardant box with contact pins projecting from the box for connecting the fuse to a printed circuit board. The fuse may, alternatively, be mounted within a cylindrical housing suited to mounting in fuse clips or holders or may be mounted in any manner enabling it to conform with known external fuse parameters.

In order that the present invention may be more readily understood, various embodiments thereof will now be described by way of example, and with reference to the accompanying drawings, in which:—

Figure 1 is a part-sectional side view of one embodiment of a time delay fuse constructed in accordance with the present invention,

Figure 2 is a view from above of the fuse of Figure 1,

Figure 3 is a side view of another embodiment

Figure 4 is a view from above of the embodiment of Figure 3,

Figure 5 is a side view of a still further embodiment, and

Figure 6 is a view from above of the embodiment of Figure 5.

Referring to the drawings, Figures 1 and 2 illustrate an electrical fuse including an insulating flame retardant housing or box 1 having contact pins 2, 2' for mounting the fuse on a printed circuit board. The pins are secured to an insulating base board 10 clipped inside the bottom of the housing and project through the housing bottom. Mounted on the base board within the housing are two conductive posts 3,4 having a fuse element secured between the posts. The fuse element comprises a conductive wire 5 having one end secured to the post 3 and its opposite end soldered at 6 to one end of a spiral spring 7 having its opposite end secured to the post 4. In this embodiment, the solder 6 provides the fusible link or connection which melts when an overload current flows through the fuse element. The spring 7 is held under tension by the wire 5 so that melting of the solder connection 6 is followed by rapid separation between the wire and spring to make a clean break in the circuit, thereby avoiding arcing.

Surrounding the wire 5 in a number of turns adjacent the solder connection 6 is a current limiting resistor 8. The latter may typically comprise a resistance wire, for example, a copper-nickel or nickel-chromium wire, spirally wound in a multiplicity of turns about an insulating core, which may be of glass-fibre. One end of the resistance wire is connected to a conductive layer 9 photo-etched onto the insulating base board 10, this conductive layer providing an electrical connection between the pin 2 and the resistor. The other end of the resistance wire is connected to the post 3 by a photo-etched conductive layer 11 and the post 4 is connected to the pin 2' by a

photo-etched conductive layer 12.

It will thus be seen that the resistor 8 is connected in series with the fuse element, which is formed by the wire 5, fusible connection 6 and spring 7, between the contact pins 2, 2'. In addition to its current limiting function, the resistor 8 acts as a heat source which is arranged to heat the fuse element. As the resistor is located close to the fusible connection 6, convected and radiated heat from the resistor assists in the operation of this fusible connection. As a result, the fuse is responsive to a minimum fusing current lower than would otherwise be required to fuse the fusible connection 6, alone. However, when the fuse is subjected to very high surge or transient overloads, the fusible connection 6 behaves in exactly the same manner as would a similar fusible element not provided with the current limiting resistor because the operation is so fast that there is insufficient time for the resistor 8 to respond. In order to achieve such overloads, sufficient voltage must exist to override the current limiting effect of the resistor.

Figures 3 and 4 illustrate a second embodiment in which integers common to the previously described embodiment have also been given the same reference numerals. In this second embodiment, the fuse element comprises a torsion spring wire 20 arranged in canti-lever fashion and extending from a short post 3. The spring 20 is turned from its unstressed position (shown in broken lines in Figure 4) and is soldered to the post 2' and 6. The current limiting resistor 8 comprises an insulated resistance wire wound about the post 4 and having one end electrically connected to the post 4. The resistor 8 is thus connected in series with the fuse element, with the connections between the pins 2, 2' and the post 3 and other end of the fuse wire being provided by photo-etched conductive layers 9, 12.

Figures 5 and 6 illustrate a third embodiment in which the current limiting resistor 8 is constructed and arranged similarly to that of the first embodiment whilst the fuse element comprises a leaf spring member 30 connected in series with a conductive wire 5 by a fusible solder connection 6. The leaf spring is secured to a short conductive post 4 and is held under tension by the conductive wire 5 which is secured at its end remote from the fusible connection to the post 3. As in the previous embodiments, the various connections between the pins 2, 2', the resistor 8 and the posts 3, 4 are provided by means of photo-etched conductive layers 9, 11, 12 formed on the base board 10 in the fuse housing.

Whilst particular embodiments have been described, it will be understood that modifications can be made without departing from the scope of the invention as defined by the appended claims. For example, similar results may be achieved by

utilising, in place of the various spring type elements, a fuse element comprising a spirally wound fuse wire having its end sections shorted out to leave only a minimum of active fusible turns at the centre, this element being wound around a flexible support of non-conductive material. Such a fuse element is fully described in the specification of our British Patent No. 1545205. The fuse element may have a eutectic blob affixed to the central active turns.

CLAIMS

1. A time delay electrical fuse comprising a fuse element and a resistor or other electrical circuit component connected in series, and the electrical circuit component serving as a heat source arranged to heat the fuse element.

2. A fuse as claimed in claim 1, in which a resistor is arranged in one or more turns about the fuse element.

3. A fuse as claimed in claim 1, in which the fuse element is electrically connected to a conductive support for the element, and the resistor is wound about the conductive support and has its turns insulated from the support.

4. A fuse as claimed in claim 1, 2 or 3, in which the resistor comprises a resistance wire wound in a multiplicity of turns about an insulating core.

5. A fuse as claimed in any one of the preceding claims, in which the fuse element comprises a spring member secured in a stressed position via a fusible link or connection.

6. A fuse as claimed in claim 5, in which the fuse element comprises a spiral spring member and a conductive wire connected in series by the fusible link or connection and mounted under tension.

7. A fuse as claimed in claim 5, in which the fuse element comprises a torsion spring member secured in a stressed position to a conductive support by the fusible link or connection.

8. A fuse as claimed in claim 5, in which the fuse element comprises a leaf spring member and a conductive wire connected in series by the fusible link or connection, said fuse element being mounted with the wire retaining the spring member in a stressed position.

9. A fuse as claimed in any one of the preceding claims 1 to 4, in which the fuse element comprises a fusible wire spirally wound in a multiplicity of turns about an insulating core.

10. A fuse as claimed in any one of the preceding claims, in which the fuse element and resistor are disposed in an insulating housing having terminal means for connecting the fuse element and resistor to an external circuit.

11. A time delay electrical fuse constructed substantially as hereinbefore described with reference to Figures 1 and 2 of the accompanying drawings.

12. A time delay electrical fuse constructed substantially as hereinbefore described with reference to Figures 3 and 4 of the accompanying drawings.

5 13. A time delay electrical fuse constructed substantially as hereinbefore described with reference to Figures 5 and 6 of the accompanying drawings.