



US009050468B2

(12) **United States Patent**
Greenberg et al.

(10) **Patent No.:** **US 9,050,468 B2**
(45) **Date of Patent:** ***Jun. 9, 2015**

(54) **FIELD OF VIEW MATCHING IN A VISUAL PROSTHESIS**

(71) Applicant: **Second Sight Medical Products, Inc.**,
San Fernando, CA (US)

(72) Inventors: **Robert J Greenberg**, Los Angeles, CA (US); **Arup Roy**, Santa Clarita, CA (US); **Avraham I Caspi**, Rehovot (IL); **Matthew J McMahon**, Washington, DC (US)

(73) Assignee: **Second Sight Medical Products, Inc.**,
Sylmar, CA (US)

(*) Notice: Subject to any disclaimer, the term of this patent is extended or adjusted under 35 U.S.C. 154(b) by 0 days.
This patent is subject to a terminal disclaimer.

(21) Appl. No.: **14/214,181**

(22) Filed: **Mar. 14, 2014**

(65) **Prior Publication Data**

US 2014/0200629 A1 Jul. 17, 2014

Related U.S. Application Data

(62) Division of application No. 14/050,003, filed on Oct. 9, 2013, now Pat. No. 8,712,537, which is a division of application No. 12/023,907, filed on Jan. 31, 2008, now Pat. No. 8,583,241.

(60) Provisional application No. 60/898,777, filed on Jan. 31, 2007.

(51) **Int. Cl.**
A61N 1/18 (2006.01)
A61N 1/36 (2006.01)

(Continued)

(52) **U.S. Cl.**
CPC **A61N 1/36046** (2013.01); **A61N 1/0543** (2013.01); **A61B 3/1005** (2013.01); **A61B 5/4836** (2013.01)

(58) **Field of Classification Search**
USPC 607/53, 54, 116
See application file for complete search history.

(56) **References Cited**

U.S. PATENT DOCUMENTS

4,573,481 A 3/1986 Bullara
4,628,933 A 12/1986 Michelson

(Continued)

FOREIGN PATENT DOCUMENTS

EP 1 637 923 A 3/2006
EP 1 721 633 A 11/2006

OTHER PUBLICATIONS

Hayes, et al., Visually Guided Performance of Simple Tasks Using Simulated Prosthetic . . . ; Jul. 2003, pp. 1016-1028, Int. Society for Artificial Organs; Blackwell Publishing.

(Continued)

Primary Examiner — Allen Porter, Jr.

(74) *Attorney, Agent, or Firm* — Scott B. Dunbar; Alessandro Steinfl

(57) **ABSTRACT**

A visual prosthesis apparatus including a video capture device for capturing a video image, a video processing unit associated with the video capture device, the video processing unit configured to convert the video image to stimulation patterns, and a stimulation system configured to stimulate subject's neural tissue based on the stimulation patterns, wherein the stimulation system provides a span of visual angle matched to the subject's neural tissue being stimulated.

7 Claims, 28 Drawing Sheets

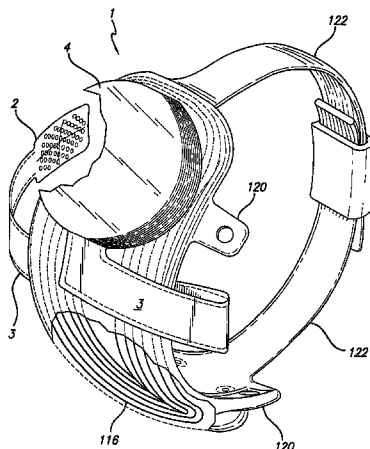

(51) **Int. Cl.**
A61B 3/10 (2006.01)
A61B 5/00 (2006.01)
A61N 1/05 (2006.01)

6,400,989 B1 6/2002 Eckmiller
6,458,157 B1 10/2002 Suaning
7,027,874 B1 * 4/2006 Sawan et al. 607/116
2002/0193845 A1 * 12/2002 Greenberg et al. 607/54
2003/0158588 A1 8/2003 Rizzo et al.
2004/0236389 A1 11/2004 Fink et al.

(56) **References Cited**

U.S. PATENT DOCUMENTS

4,837,049 A 6/1989 Byers et al.
5,109,844 A 5/1992 de Juan, Jr. et al.
5,215,088 A 6/1993 Normann et al.
5,935,155 A 8/1999 Humayun et al.

OTHER PUBLICATIONS

Cha, et al., Simulation of a Phosphene-Based Visual Field: . . . ;
Annals of Biomedical Engineering, 1992, pp. 439-449, vol. 20,
Pergamon Press Ltd.

* cited by examiner

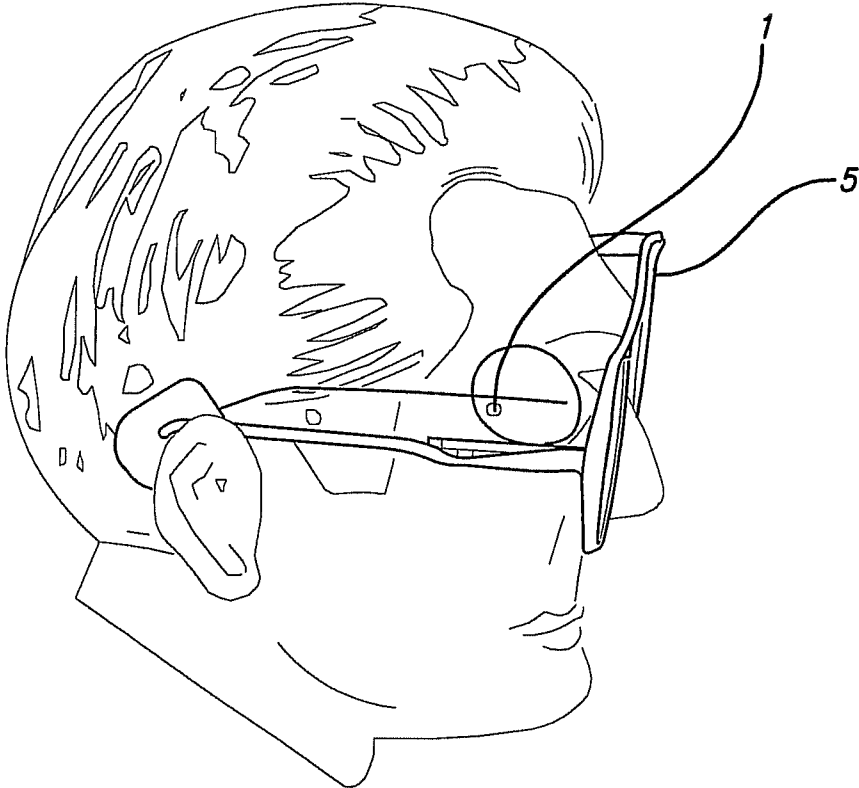

FIG. 1

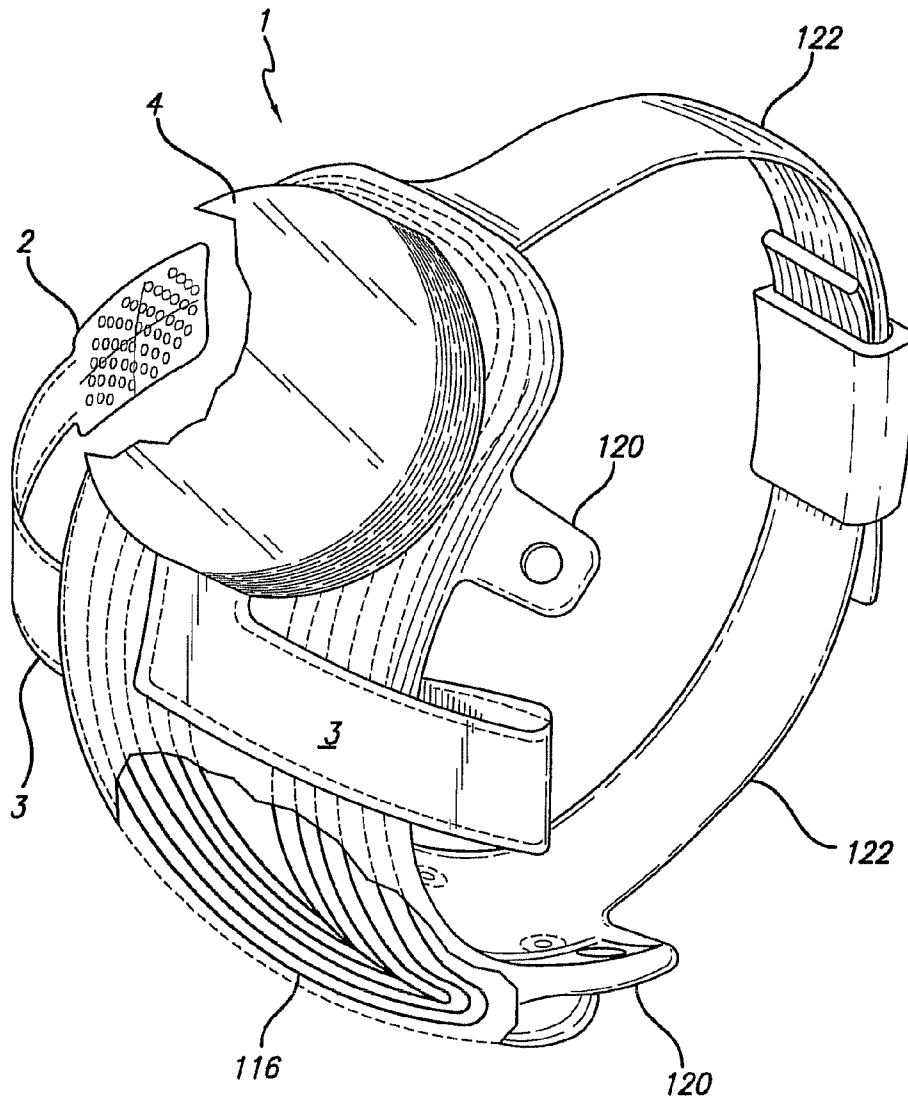

FIG. 2

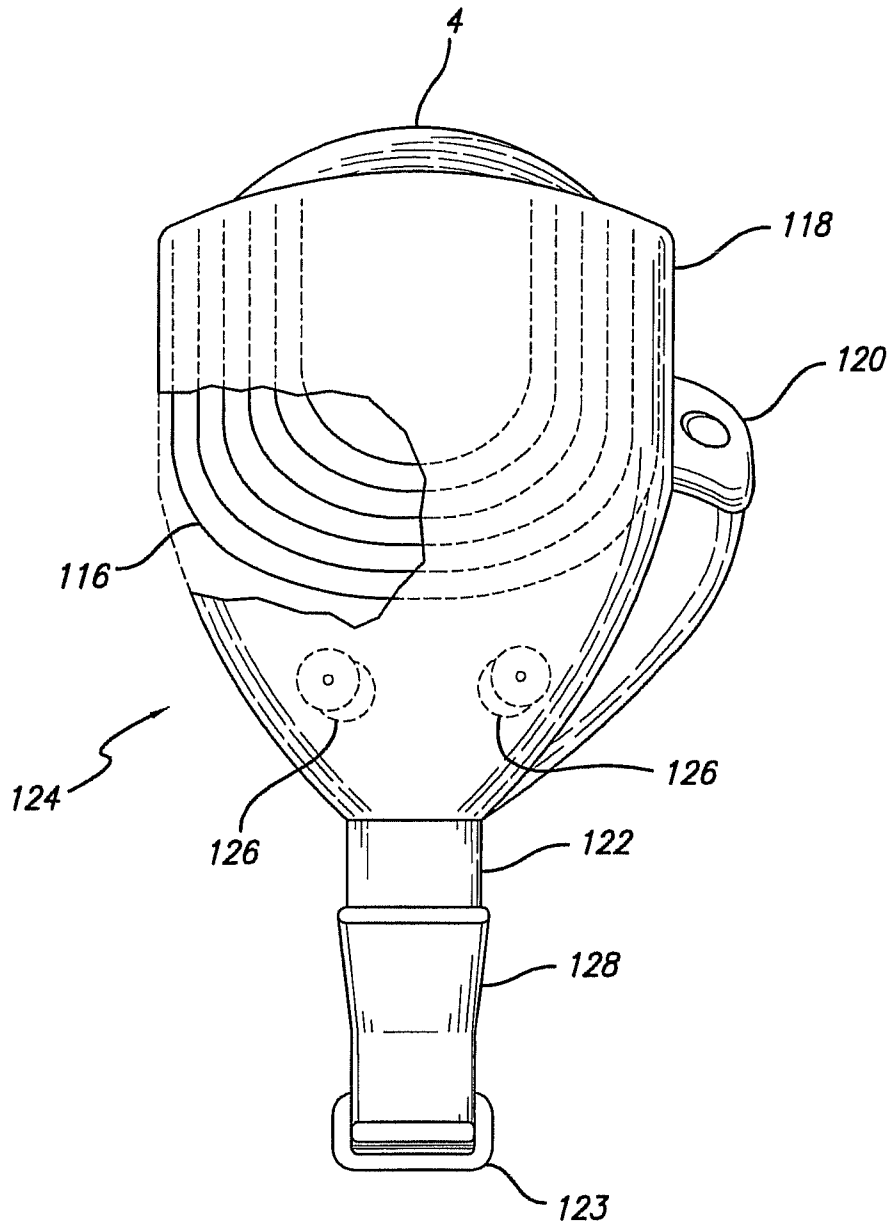

FIG. 3

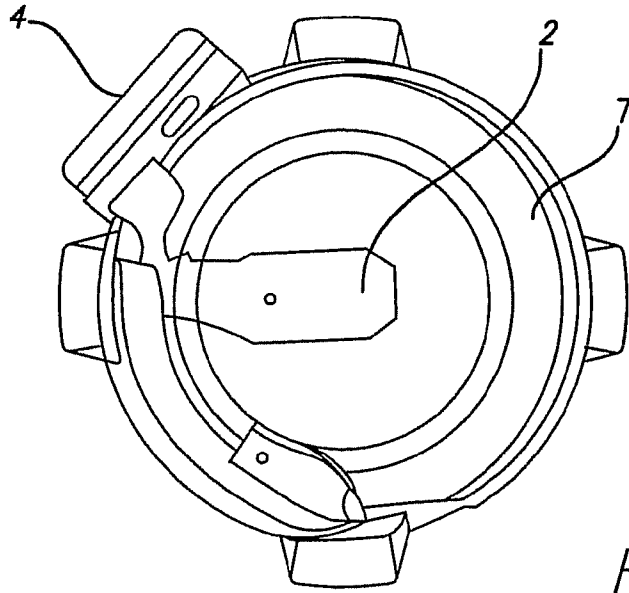

FIG. 4

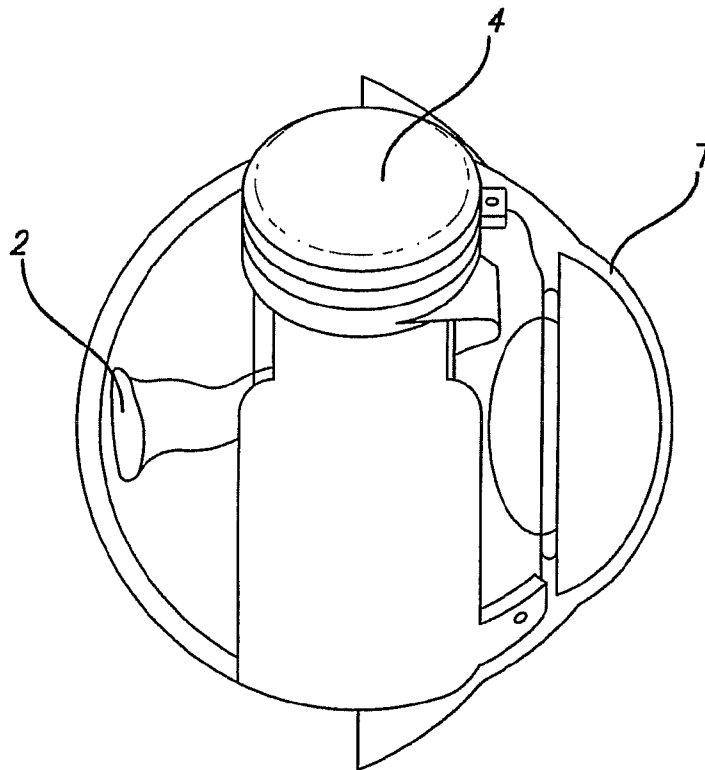

FIG. 5

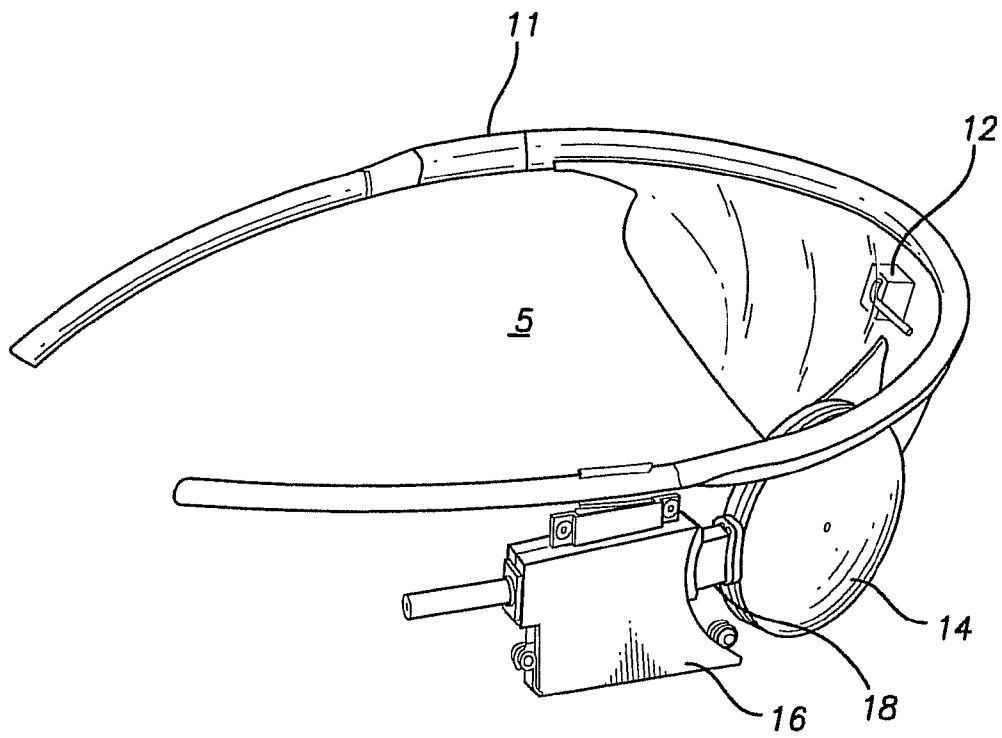

FIG. 6A

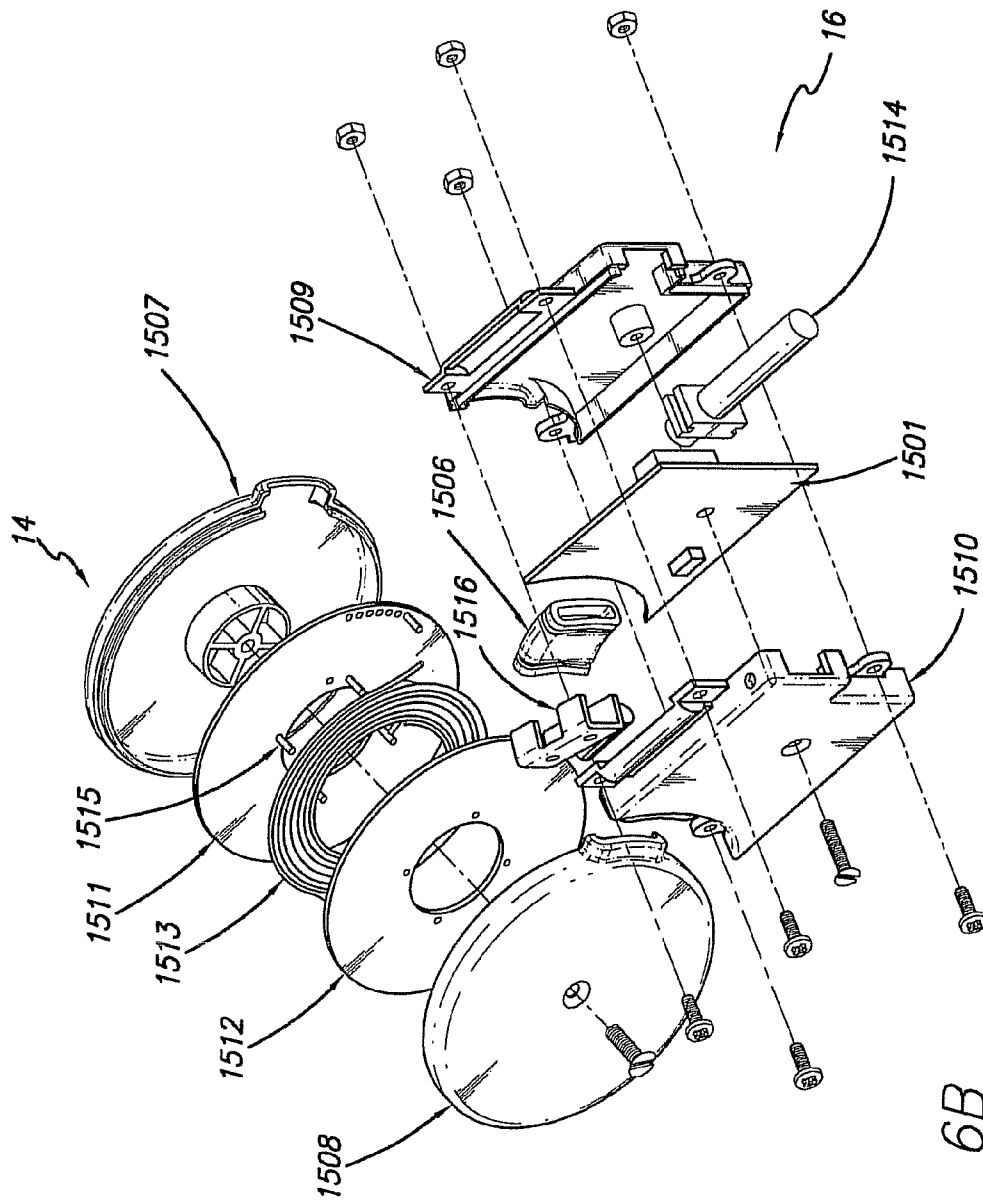

FIG. 6B

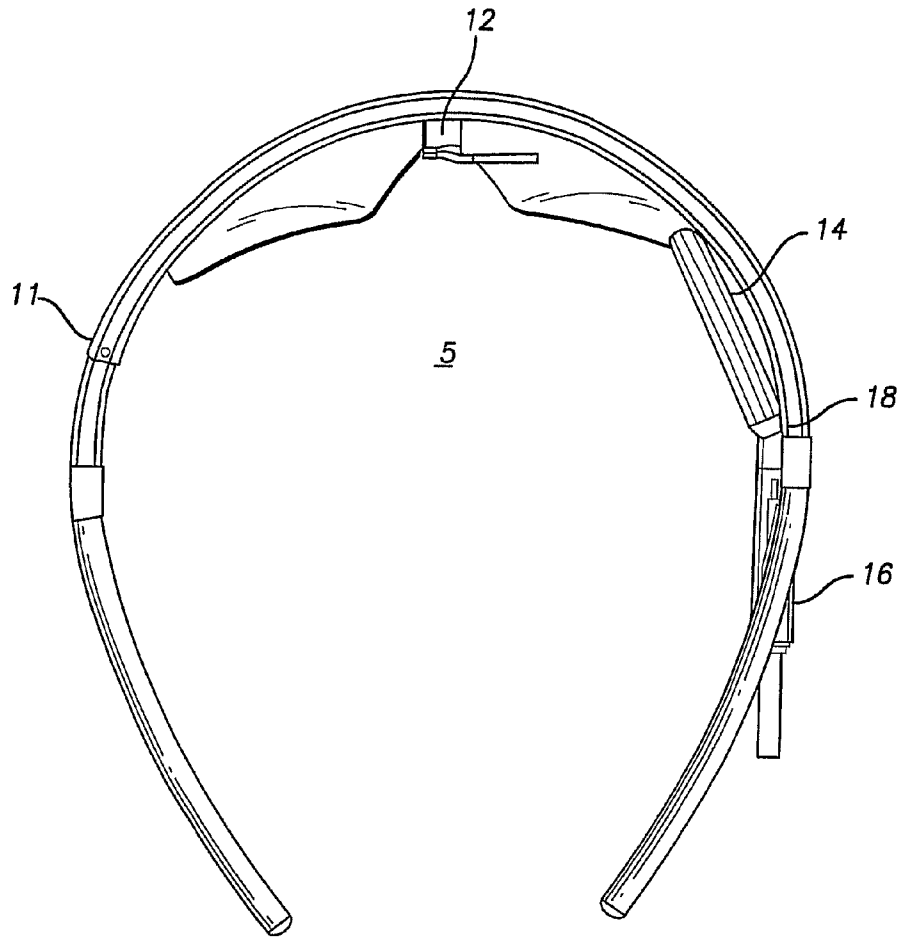

FIG. 7

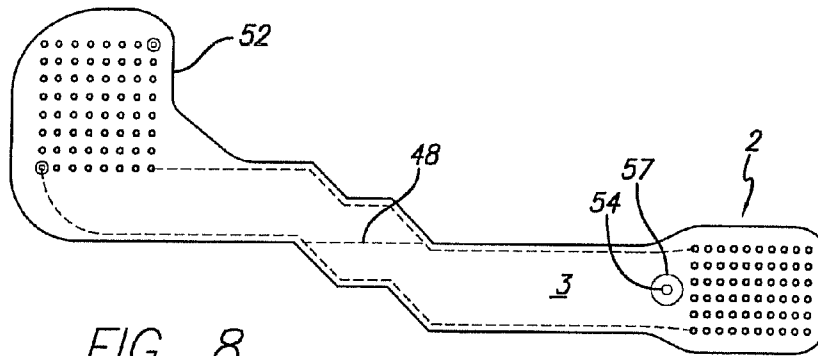

FIG. 8

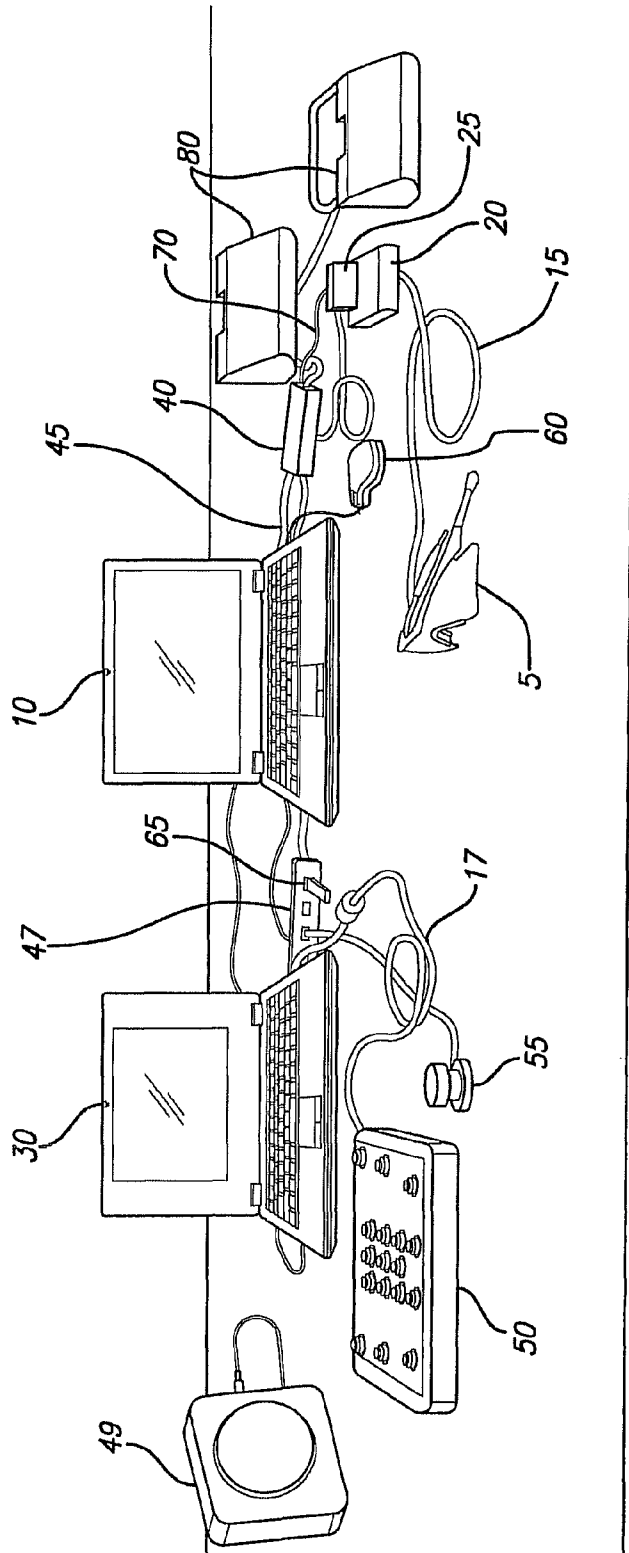

FIG. 9

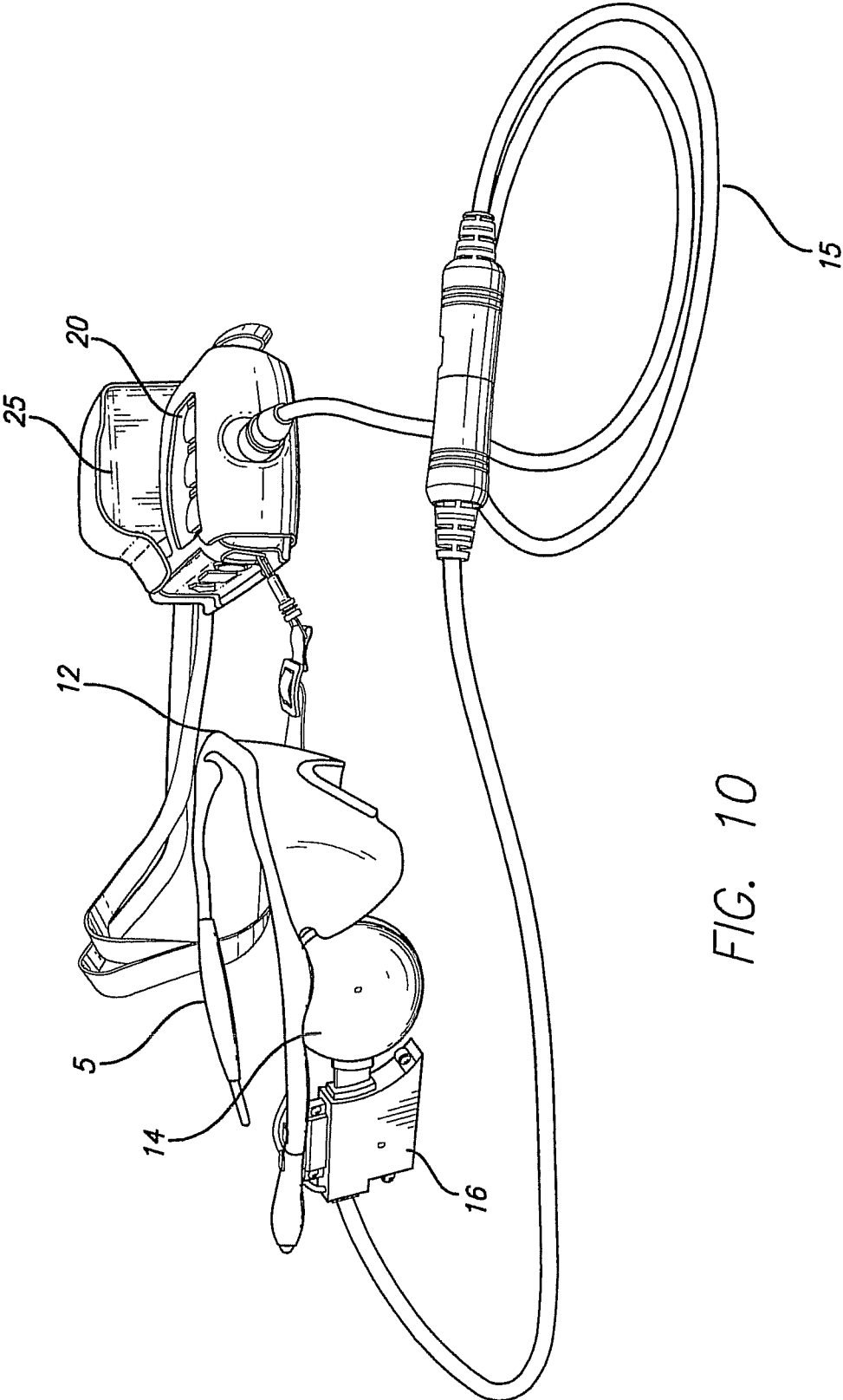

FIG. 10

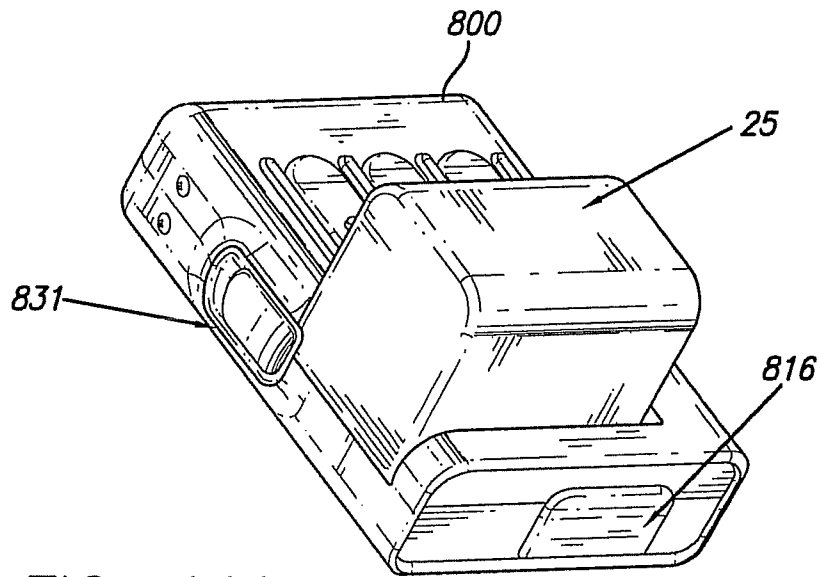

FIG. 11A

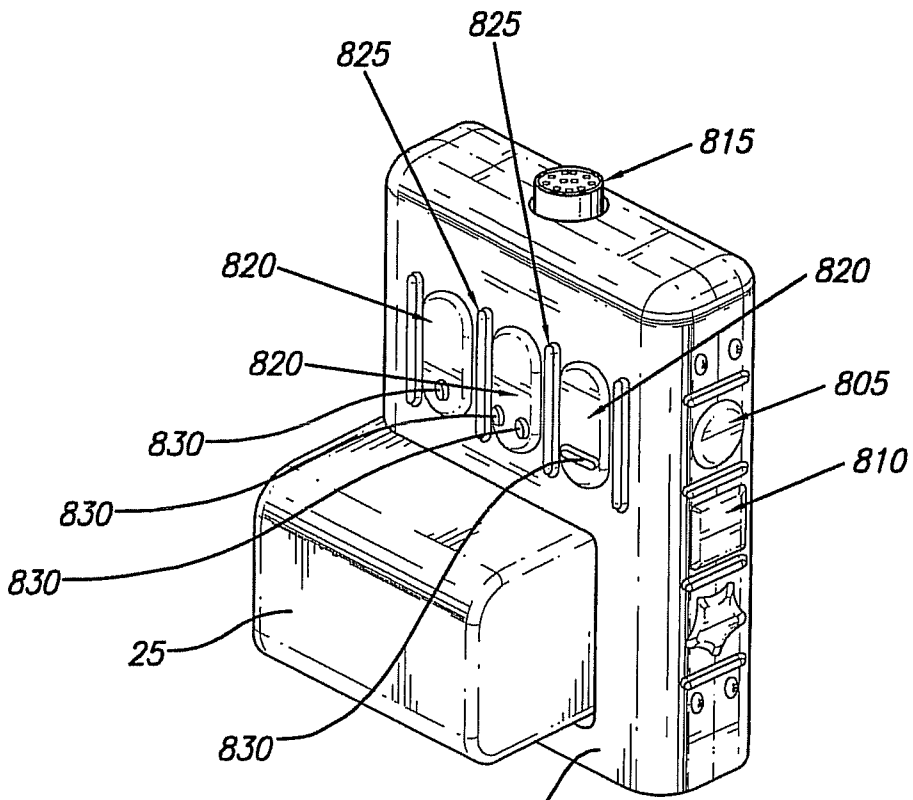

FIG. 12

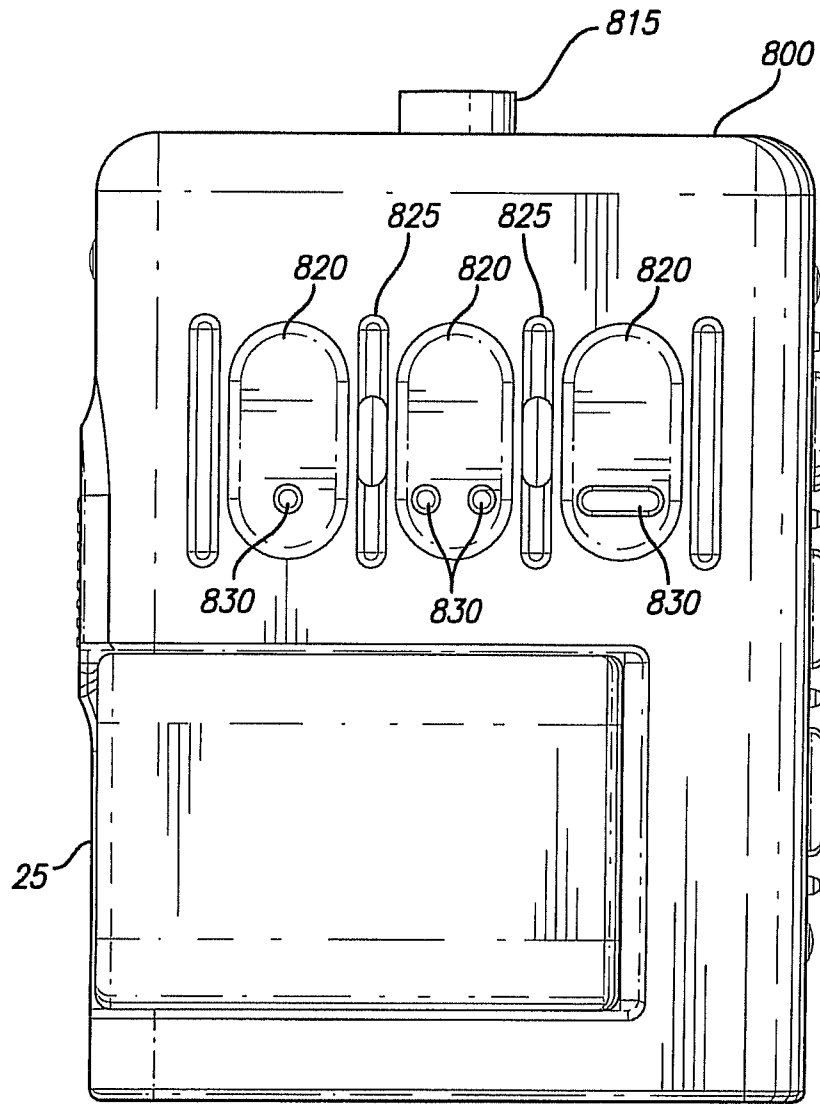

FIG. 11B

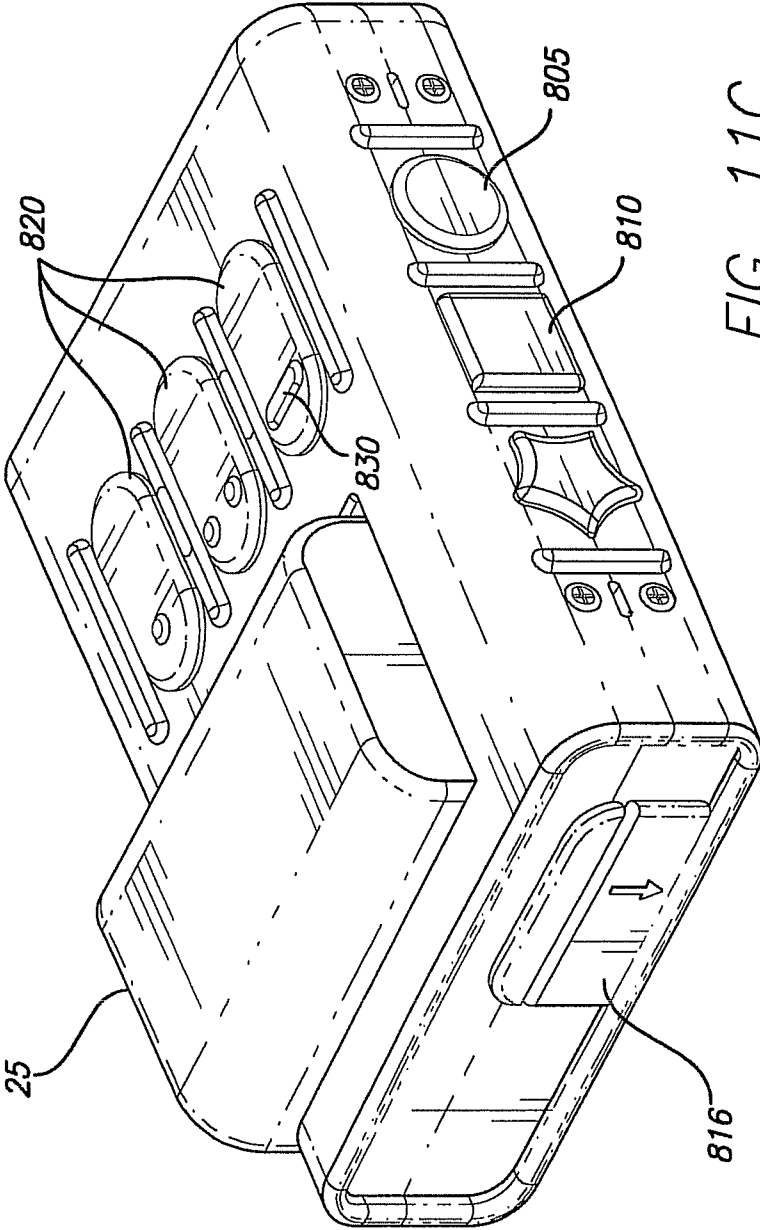

FIG. 11C

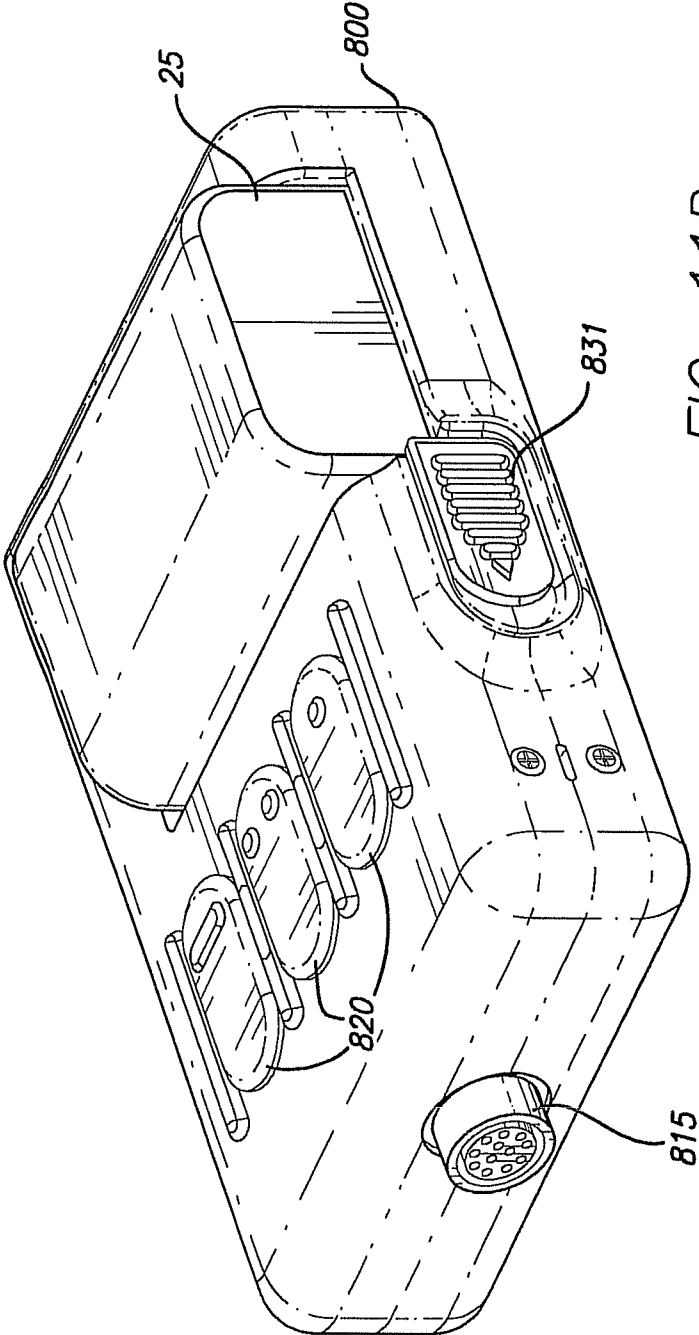

FIG. 11D

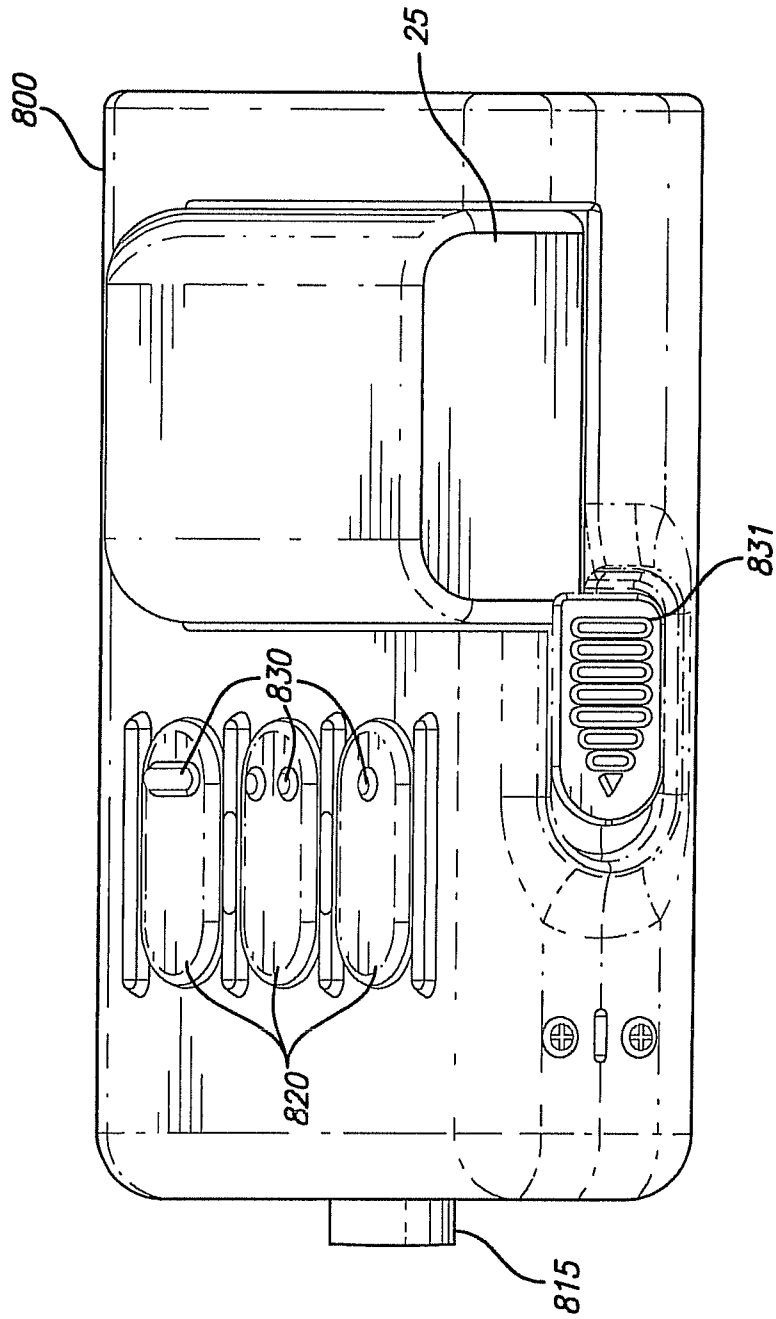

FIG. 11E

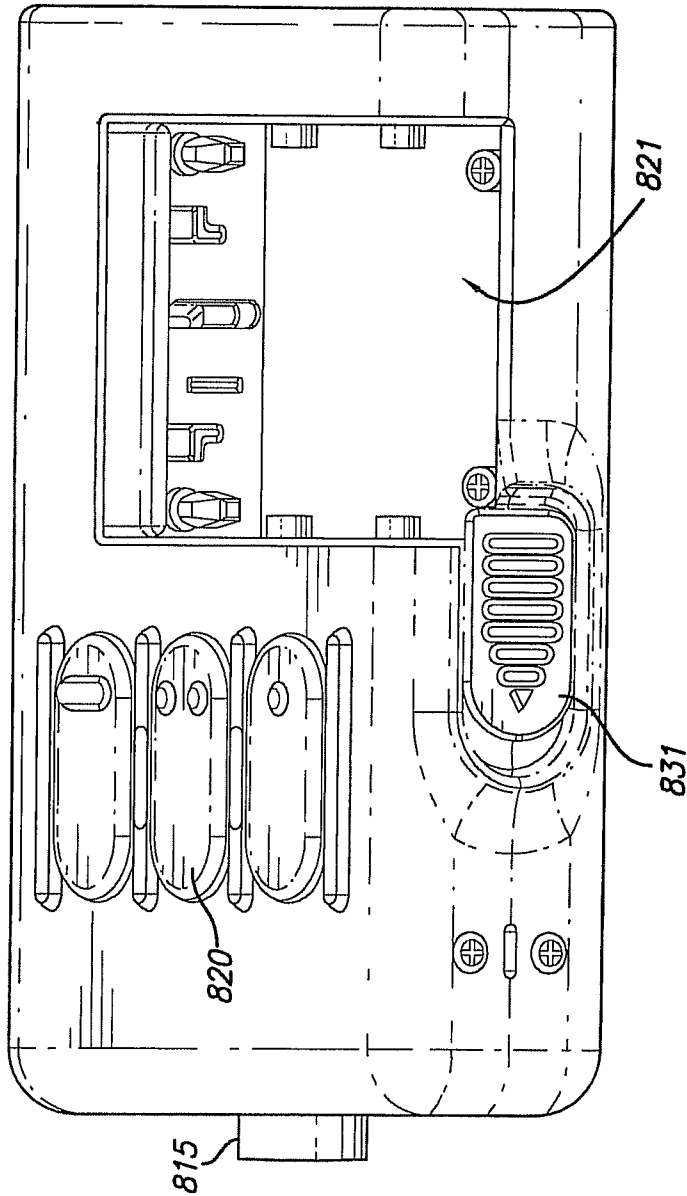

FIG. 11F

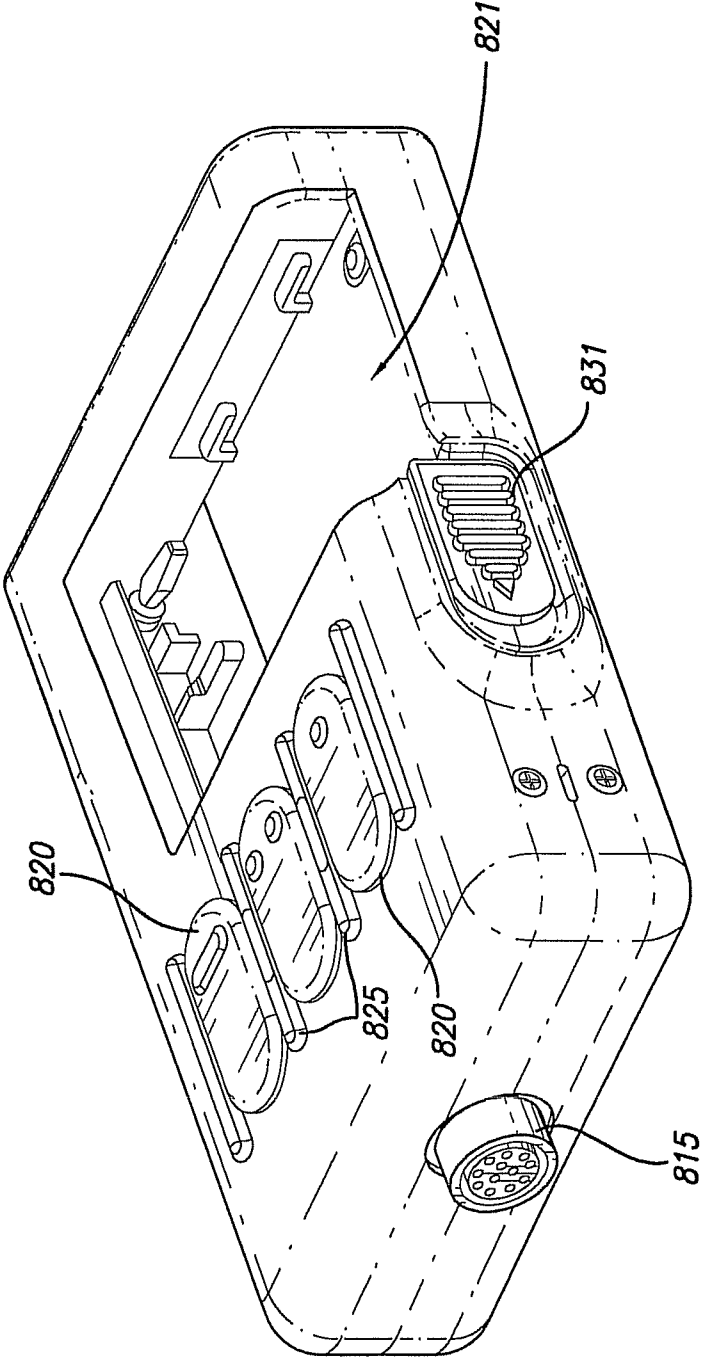

FIG. 11G

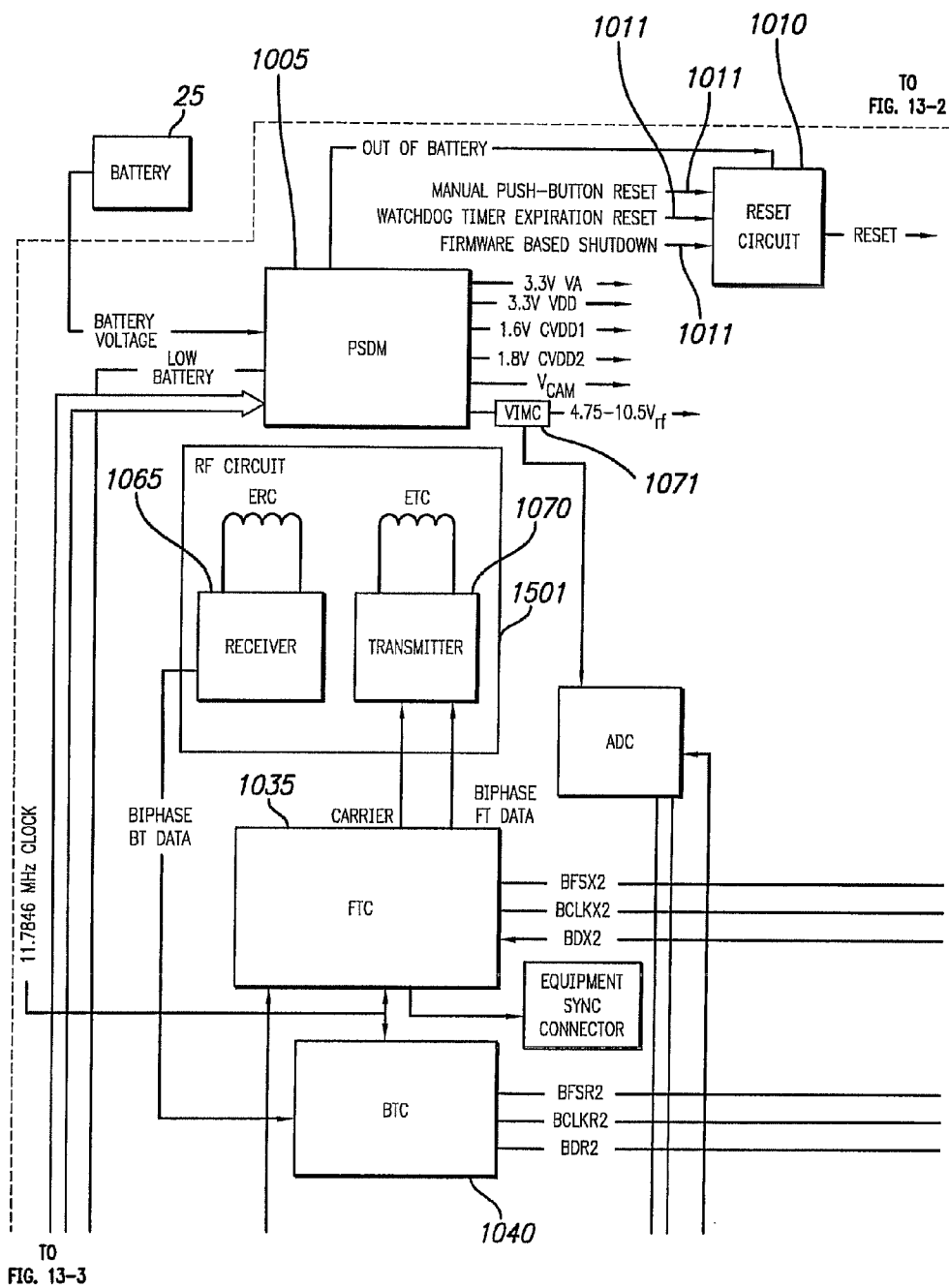

FIG. 13-1

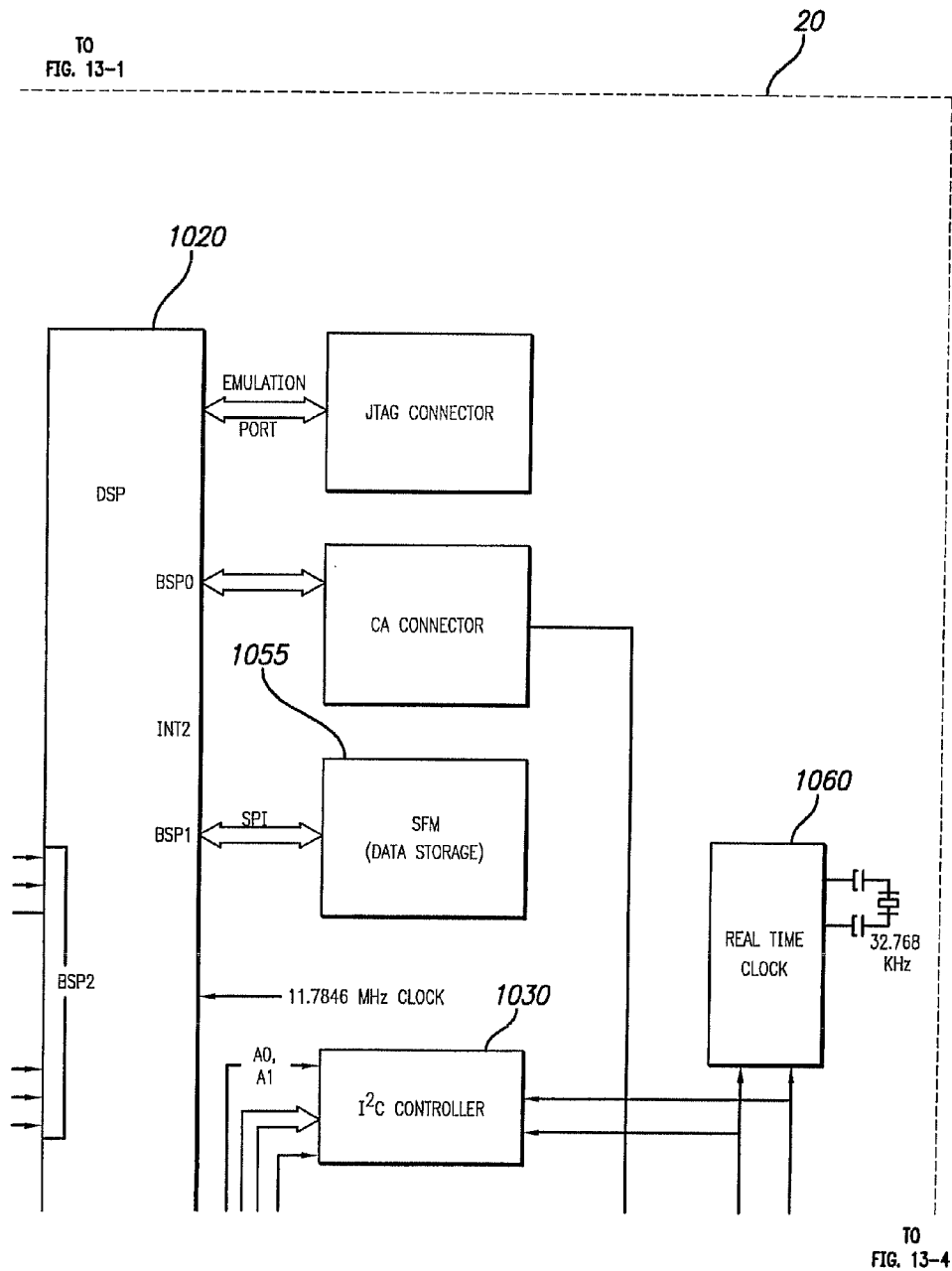

FIG. 13-2

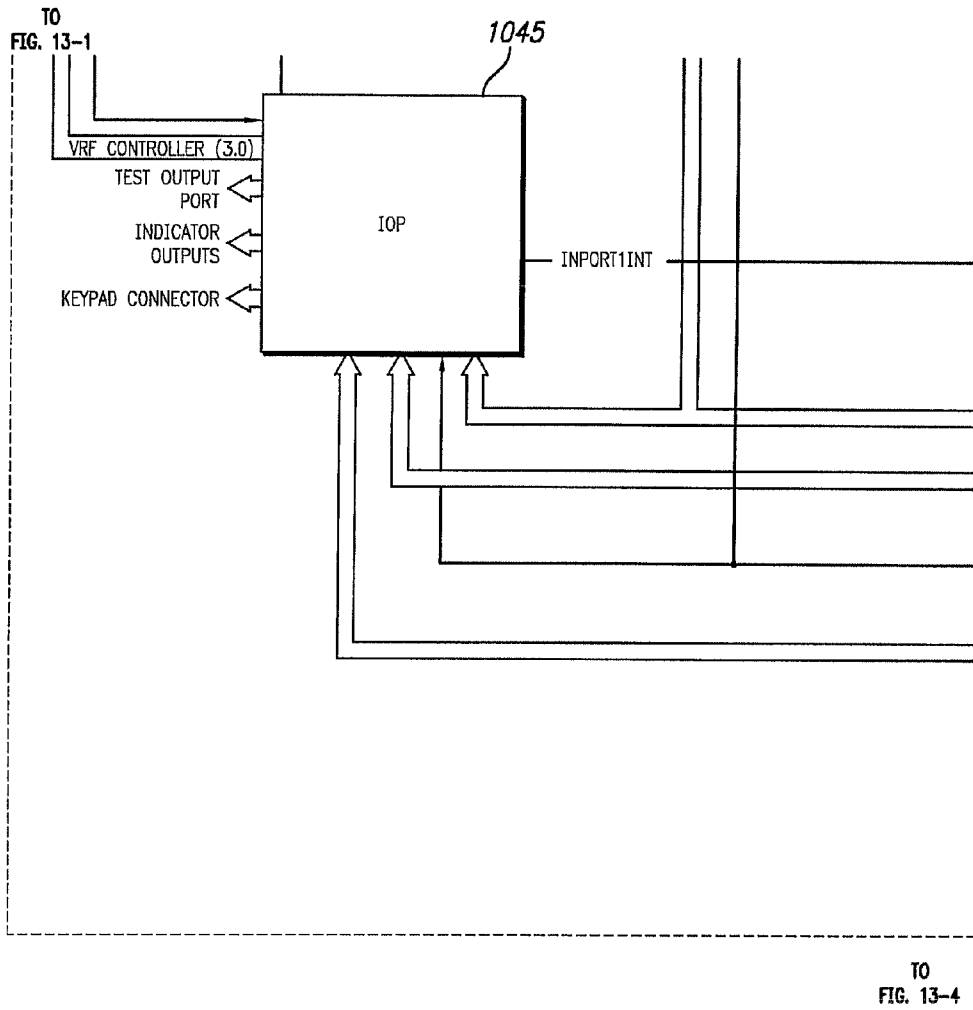

FIG. 13-3

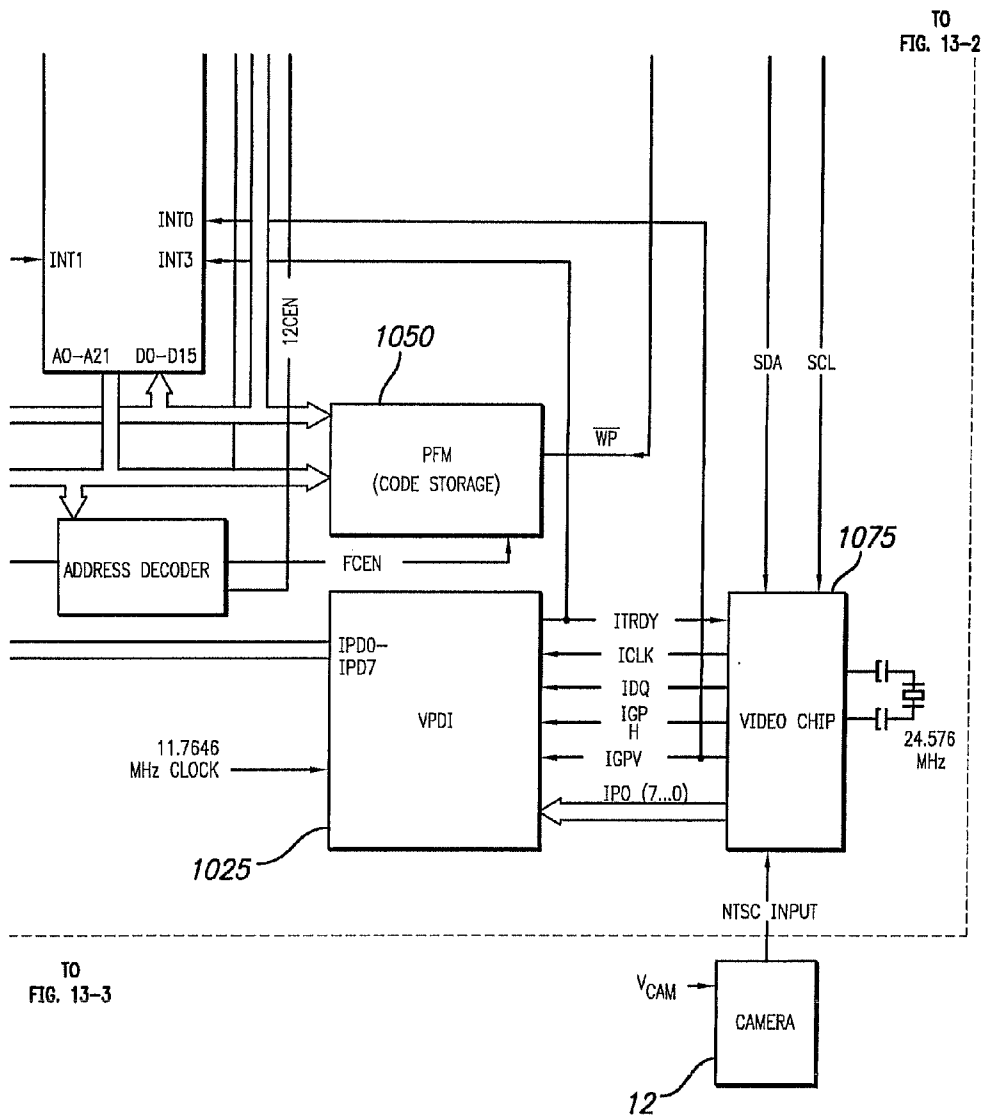

FIG. 13-4

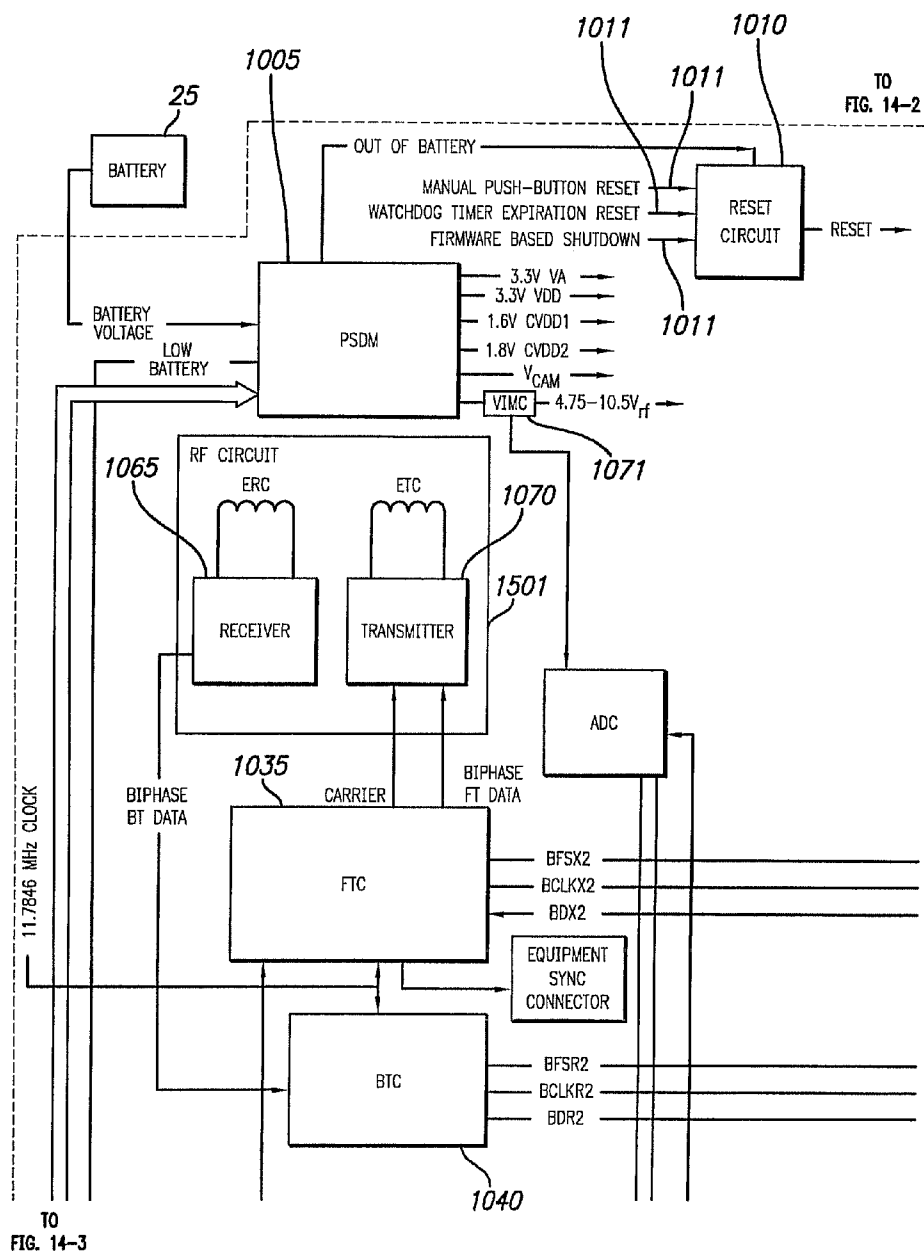

FIG. 14-1

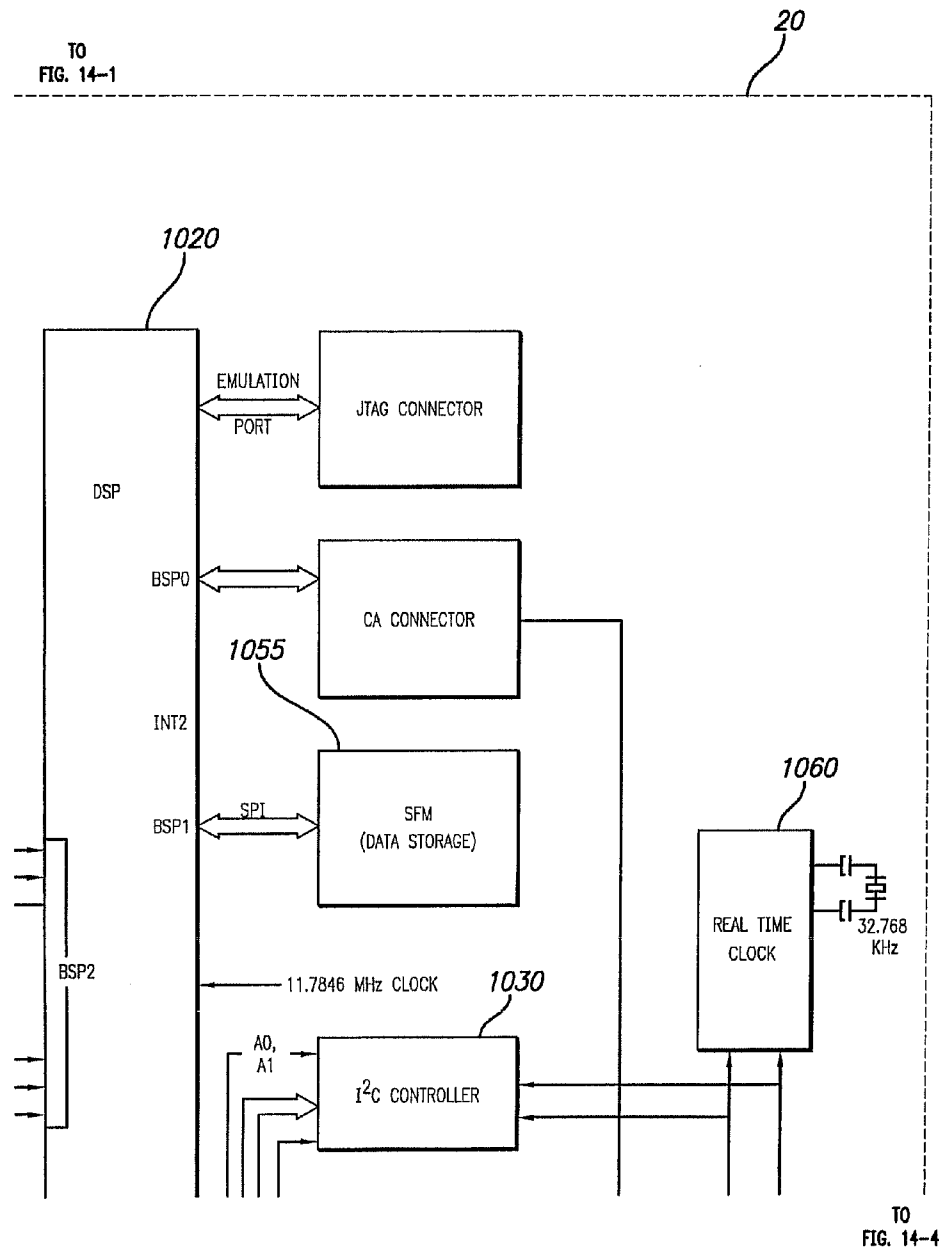

FIG. 14-2

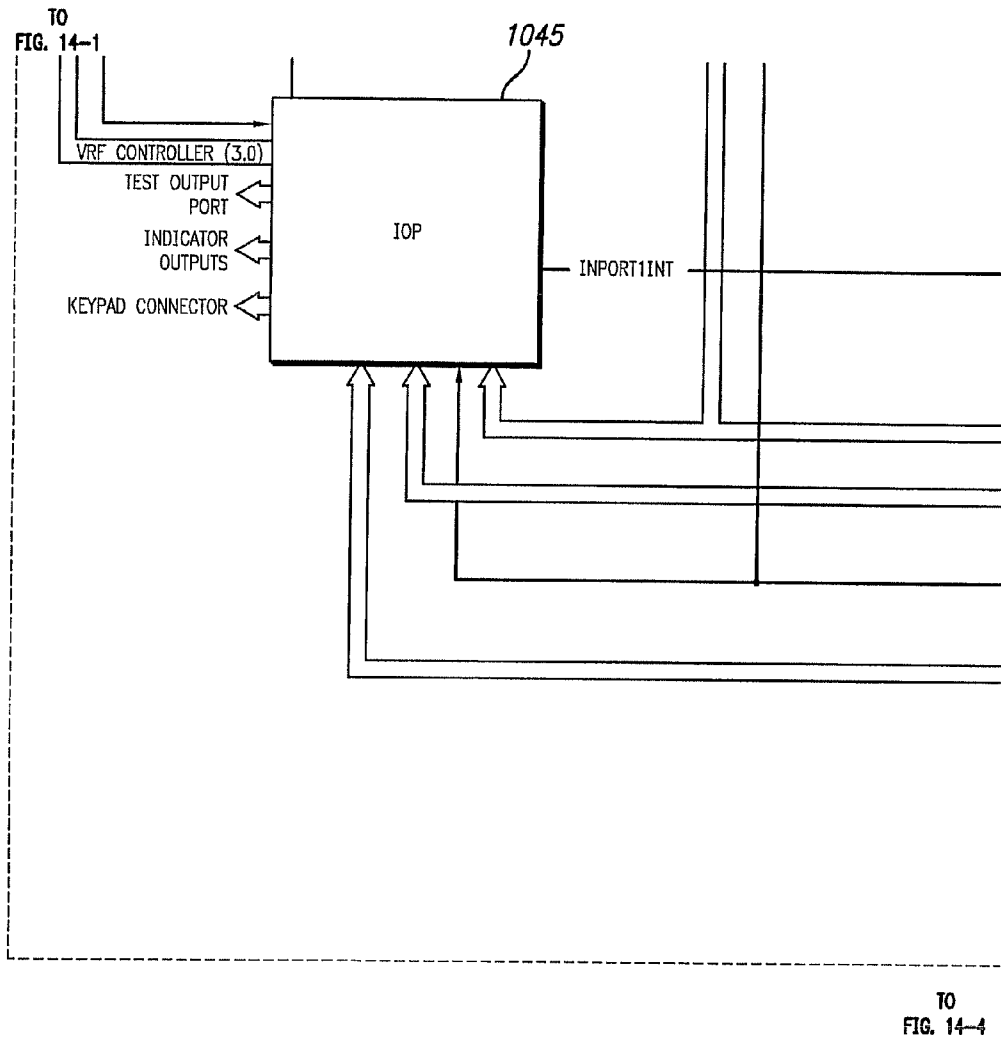

FIG. 14-3

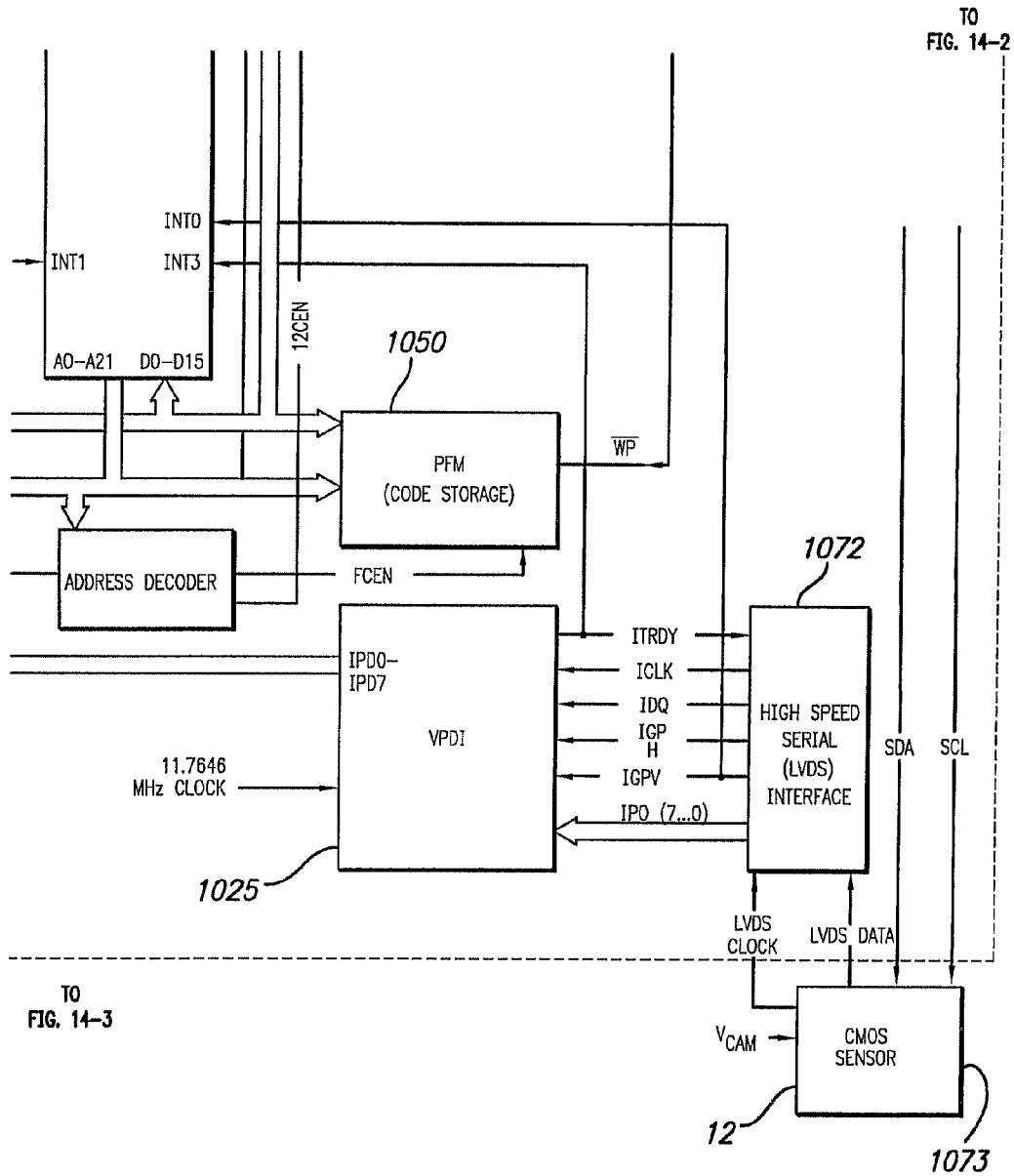

FIG. 14-4

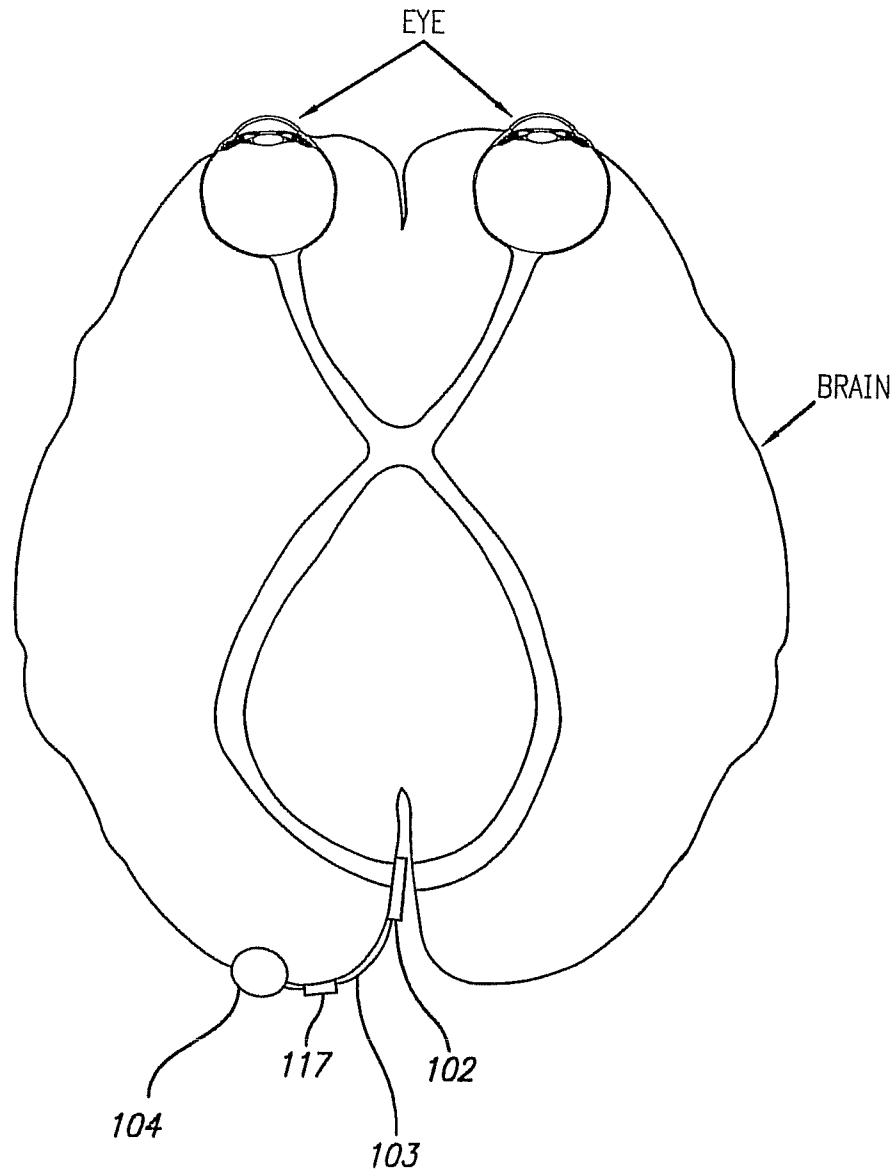

FIG. 15

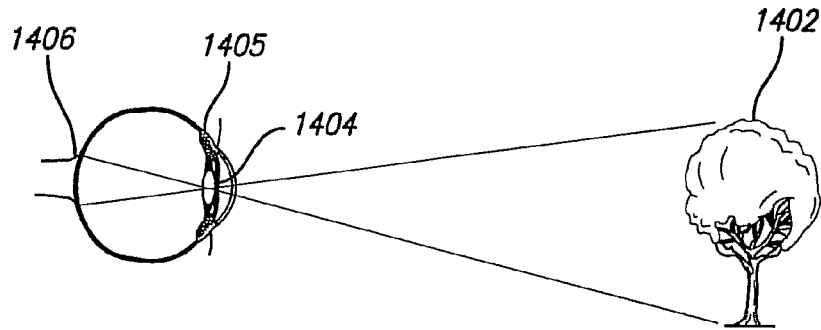

FIG. 16

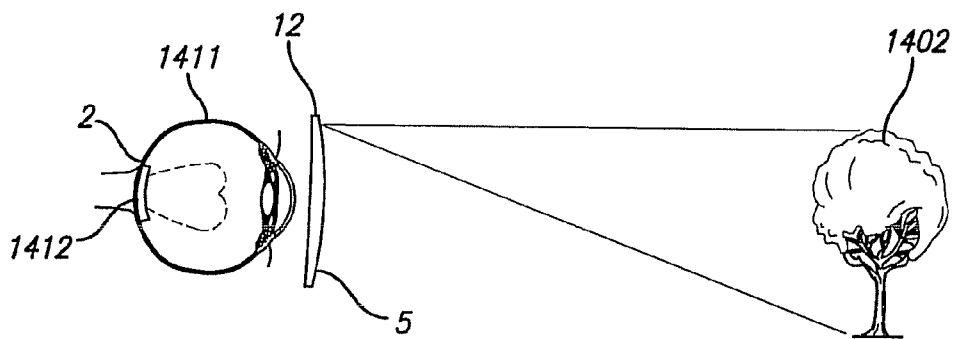

FIG. 17



FIG. 18

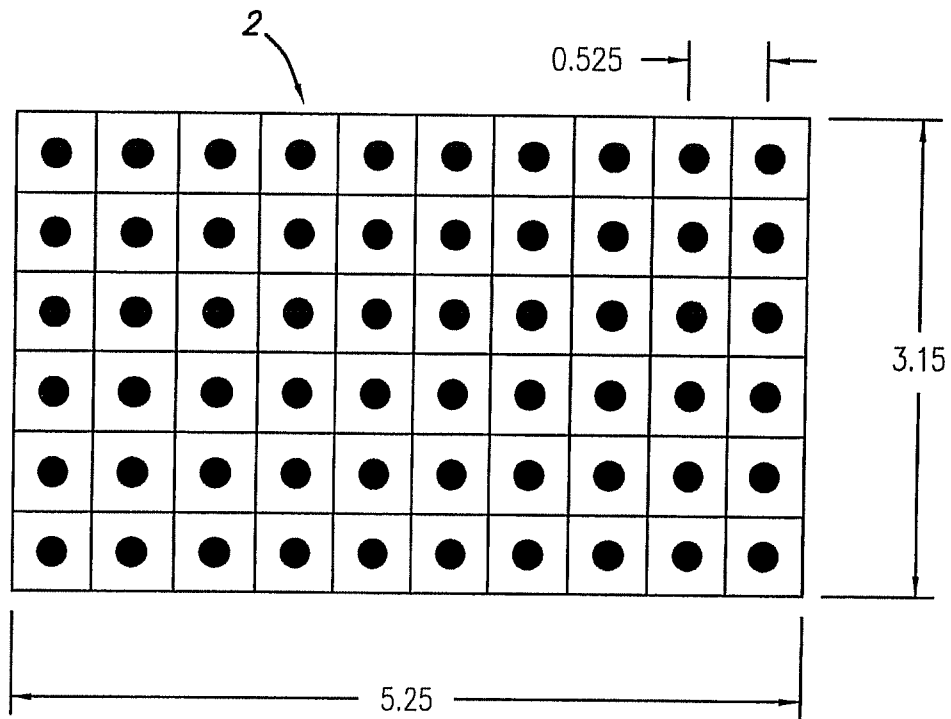

FIG. 19

FIELD OF VIEW MATCHING IN A VISUAL PROSTHESIS

CROSS REFERENCE TO RELATED APPLICATIONS

This application is a divisional application of U.S. patent application Ser. No. 14/050,003, filed Oct. 9, 2013, for Field of View Matching in a Visual Prosthesis, which is a divisional application of U.S. patent application Ser. No. 12/023,907, filed Jan. 31, 2008, now U.S. Pat. No. 8,583,241, for Field of View Matching in a Visual Prosthesis, which claims the benefit of to U.S. Provisional Application Ser. No. 60/898,777, filed Jan. 31, 2007 for Field of View Matching in a Visual Prosthesis, the disclosure of which is incorporated herein by reference in its entirety.

FEDERALLY SPONSORED RESEARCH OR DEVELOPMENT

The present invention was made with support from the United States Government under Grant number R24EY12893-01, awarded by the National Institutes of Health. The United States Government has certain rights in the invention.

FIELD

The present invention is generally directed to neural stimulation and more specifically to an improved method of communication information to users and clinicians while fitting a visual prosthesis.

BACKGROUND

In 1755 LeRoy passed the discharge of a Leyden jar through the orbit of a man who was blind from cataract and the patient saw "flames passing rapidly downwards." Ever since, there has been a fascination with electrically elicited visual perception. The general concept of electrical stimulation of retinal cells to produce these flashes of light or phosphenes has been known for quite some time. Based on these general principles, some early attempts at devising a prosthesis for aiding the visually impaired have included attaching electrodes to the head or eyelids of patients. While some of these early attempts met with some limited success, these early prosthetic devices were large, bulky and could not produce adequate simulated vision to truly aid the visually impaired.

In the early 1930's, Foerster investigated the effect of electrically stimulating the exposed occipital pole of one cerebral hemisphere. He found that, when a point at the extreme occipital pole was stimulated, the patient perceived a small spot of light directly in front and motionless (a phosphene). Subsequently, Brindley and Lewin (1968) thoroughly studied electrical stimulation of the human occipital (visual) cortex. By varying the stimulation parameters, these investigators described in detail the location of the phosphenes produced relative to the specific region of the occipital cortex stimulated. These experiments demonstrated: (1) the consistent shape and position of phosphenes; (2) that increased stimulation pulse duration made phosphenes brighter; and (3) that there was no detectable interaction between neighboring electrodes which were as close as 2.4 mm apart.

As intraocular surgical techniques have advanced, it has become possible to apply stimulation on small groups and even on individual retinal cells to generate focused phosph-

phenes through devices implanted within the eye itself. This has sparked renewed interest in developing methods and apparatuses to aid the visually impaired. Specifically, great effort has been expended in the area of intraocular visual prosthesis devices in an effort to restore vision in cases where blindness is caused by photoreceptor degenerative retinal diseases such as retinitis pigmentosa and age related macular degeneration which affect millions of people worldwide.

Neural tissue can be artificially stimulated and activated by prosthetic devices that pass pulses of electrical current through electrodes on such a device. The passage of current causes changes in electrical potentials across visual neuronal membranes, which can initiate visual neuron action potentials, which are the means of information transfer in the nervous system.

Based on this mechanism, it is possible to input information into the nervous system by coding the information as a sequence of electrical pulses which are relayed to the nervous system via the prosthetic device. In this way, it is possible to provide artificial sensations including vision.

One typical application of neural tissue stimulation is in the rehabilitation of the blind. Some forms of blindness involve selective loss of the light sensitive transducers of the retina. Other retinal neurons remain viable, however, and may be activated in the manner described above by placement of a prosthetic electrode device on the inner (toward the vitreous) retinal surface (epiretinal). This placement must be mechanically stable, minimize the distance between the device electrodes and the visual neurons, and avoid undue compression of the visual neurons.

In 1986, Bullara (U.S. Pat. No. 4,573,481) patented an electrode assembly for surgical implantation on a nerve. The matrix was silicone with embedded iridium electrodes. The assembly fit around a nerve to stimulate it.

Dawson and Radtke stimulated cat's retina by direct electrical stimulation of the retinal ganglion cell layer. These experimenters placed nine and then fourteen electrodes upon the inner retinal layer (i.e., primarily the ganglion cell layer) of two cats. Their experiments suggested that electrical stimulation of the retina with 30 to 100 uA current resulted in visual cortical responses. These experiments were carried out with needle-shaped electrodes that penetrated the surface of the retina (see also U.S. Pat. No. 4,628,933 to Michelson).

The Michelson '933 apparatus includes an array of photosensitive devices on its surface that are connected to a plurality of electrodes positioned on the opposite surface of the device to stimulate the retina. These electrodes are disposed to form an array similar to a "bed of nails" having conductors which impinge directly on the retina to stimulate the retinal cells. U.S. Pat. No. 4,837,049 to Byers describes spike electrodes for neural stimulation. Each spike electrode pierces neural tissue for better electrical contact. U.S. Pat. No. 5,215,088 to Norman describes an array of spike electrodes for cortical stimulation. Each spike pierces cortical tissue for better electrical contact.

The art of implanting an intraocular prosthetic device to electrically stimulate the retina was advanced with the introduction of retinal tacks in retinal surgery. De Juan, et al. at Duke University Eye Center inserted retinal tacks into retinas in an effort to reattach retinas that had detached from the underlying choroid, which is the source of blood supply for the outer retina and thus the photoreceptors. See, e.g., E. de Juan, et al., 99 Am. J. Ophthalmol. 272 (1985). These retinal tacks have proved to be biocompatible and remain embedded in the retina, and choroid/sclera, effectively pinning the retina against the choroid and the posterior aspects of the globe. Retinal tacks are one way to attach a retinal array to the retina.

U.S. Pat. No. 5,109,844 to de Juan describes a flat electrode array placed against the retina for visual stimulation. U.S. Pat. No. 5,935,155 to Humayun describes a visual prosthesis for use with the flat retinal array described in de Juan.

SUMMARY

According to a first aspect, a visual prosthesis apparatus is disclosed, the visual prosthesis apparatus comprising: a video capture device for capturing a video image; a video processing unit associated with the video capture device, the video processing unit configured to convert the video image to stimulation patterns; and a stimulation system configured to stimulate subject's neural tissue based on the stimulation patterns, wherein the stimulation system provides a span of visual angle matched to the subject's neural tissue being stimulated.

According to a second aspect, a method for determining for determining a field of view of an electrode array implanted on a subject's retina is disclosed, the method comprising: determining physical dimensions of a subject's eye; providing an electrode array; and calculating a field of view of the area of the retina stimulated by the electrode array based on the physical dimensions of the subject's eye and dimensions of the electrode array.

According to a third aspect, a method for stimulating a subject's eye is disclosed, the method comprising: capturing a video image; converting the video image to stimulation patterns; and stimulating subject's neural tissue based on the stimulation patterns, wherein the stimulation patterns provide a span of about 10.8 degrees by about 17.9 degrees of visual angle to the subject's stimulated neural tissue.

According to a fourth aspect, a method for determining a field of view of an electrode array implanted on a subject's retina is disclosed, the method comprising: determining a vertical length and a horizontal length of the subject's neural tissue being stimulated by stimulation patterns; determining a vertical visual angle of an electrode array by multiplying the vertical length by (1 degree/0.293 mm); and determining a horizontal visual angle of the electrode array by multiplying the horizontal length by (1 degree/0.293 mm).

According to a fifth aspect, a video processing unit is disclosed, the video processing unit comprising: a zoom-in button; a zoom-out button; and a default zoom button, wherein a video capture device associated with the video processing unit provides a default zoom when the default zoom button is activated, wherein the video capture device doubles the size of the default zoom when the zoom-in button is activated, and wherein the video capture device provides half the default zoom when the zoom-out button is activated.

Further embodiments are shown in the specification, drawings and claims of the present application.

BRIEF DESCRIPTION OF THE FIGURES

FIG. 1 shows a visual prosthesis apparatus according to the present disclosure.

FIGS. 2 and 3 show a retinal stimulation system adapted to be implanted into a subject.

FIG. 4 shows a front view of the implanted retinal stimulation system.

FIG. 5 shows a side view of the implanted system of FIG. 9.

FIGS. 6A and 7 show a video capture/transmission apparatus or visor adapted to be used in combination with the retinal stimulation system of FIGS. 2-5.

FIG. 6B shows exploded view of the external coil arrangement and mounting system shown in FIGS. 6A and 7.

FIG. 8 shows a flexible circuit electrode array, also shown in FIG. 2.

FIG. 9 shows components of a fitting system according to the present disclosure, the system also comprising the visor shown in FIGS. 6A-6B and 7.

FIG. 10 shows the visual prosthesis apparatus in a stand-alone mode, i.e. comprising the visor connected to a video processing unit.

FIGS. 11A-G and 12 show the video processing unit already briefly shown with reference to FIGS. 9 and 10.

FIGS. 13-1, 13-2, 13-3 and 13-4 show an exemplary embodiment of a video processing unit.

FIG. 13-1 should be viewed at the left of FIG. 13-2. FIG. 13-3 should be viewed at the left of FIG. 13-4. FIGS. 13-1 and 13-2 should be viewed on top of FIGS. 13-3 and 13-4.

FIGS. 14-1, 14-2, 14-3 and 14-4 show another exemplary embodiment of a video processing unit. FIG. 14-1 should be viewed at the left of FIG. 14-2. FIG. 14-3 should be viewed at the left of FIG. 14-4. FIGS. 14-1 and 14-2 should be viewed on top of FIGS. 14-3 and 14-4.

FIG. 15 shows an exemplary embodiment of using an implantable visual prosthesis to stimulate the visual cortex of the brain according to the present application.

FIG. 16 shows natural field of view of a view.

FIG. 17 shows a field of view as seen by a camera.

FIG. 18 shows a field of view as seen by an eye with an electrode array.

FIG. 19 shows an exemplary embodiment of an electrode array according to the present application.

Appendix A showing a photocopy of page 96 from The Human Eye, Structure and Function Clyde W. Oyster; Sinauer Associates, Sunderland, Mass., 1999, ISBN 0-87893-645-9.

In the following description, like reference numbers are used to identify like elements. Furthermore, the drawings are intended to illustrate major features of exemplary embodiments in a diagrammatic manner. The drawings are not intended to depict every feature of every implementation nor relative dimensions of the depicted elements, and are not drawn to scale.

DETAILED DESCRIPTION

The present disclosure is concerned with a visual apparatus and a method for creation of artificial vision. In particular, the present disclosure provides an interface and method for controlling a visual prosthesis (i.e. device) implanted in an individual patient (i.e. subject) to create artificial vision.

FIG. 1 shows a visual prosthesis apparatus. The visual apparatus comprises, in combination, an implantable retinal stimulation system 1 and a video capture/transmission apparatus or visor embodied in visor/Glasses 5. An exemplary retinal stimulation system 1 is shown in more detail in FIGS. 2-5 and an exemplary visor 5 is shown in more detail in FIGS. 6 and 7.

The retinal stimulation system 1 is further disclosed in U.S. application Ser. No. 11/207,644, filed Aug. 19, 2005 for "Flexible Circuit Electrode Array" by Robert J. Greenberg, et. al. incorporated herein by reference, and is intended for use in subjects with retinitis pigmentosa. The visor 5 is further disclosed in International Patent Application No. PCT/US07/13918, filed on Jun. 14, 2007 and entitled "APPARATUS AND METHOD FOR ELECTRICAL STIMULATION OF HUMAN RETINA," also incorporated herein by reference.

5

The exemplary retinal stimulation system **1**, shown in FIGS. **2** and **3**, is an implantable electronic device containing an inductive coil **116** and an electrode array **2** that is electrically coupled by a cable **3** that pierces sclera of the subject's eye to an electronics package **4**, external to the sclera. The retinal stimulation system **1** is designed, for example, to elicit visual percepts in blind subjects with retinitis pigmentosa.

Human vision provides a field of view that is wider than it is high. This is partially due to fact that we have two eyes, but even a single eye provides a field of view that is approximately 90° high and 140° to 160° degrees wide. It is therefore, advantageous to mimic the visual systems emphasis on the horizontal visual field by providing a flexible circuit electrode array **2** that is wider than it is tall. This is equally applicable to a cortical visual array. In which case, the wider dimension on the cortical surface would correspond to horizontal in the visual scene.

FIG. **8** shows the flexible circuit electrode array **2** prior to folding and attaching to the electronics package **4** of FIG. **2**. At one end of the flexible circuit cable **3** is an interconnection pad **52** for connection to the electronics package **4**. At the other end of the flexible circuit cable **3** is the flexible circuit electrode array **2**. Further, an attachment point **54** may be provided near the flexible circuit electrode array **2**. A retina tack (not shown) is placed through the attachment point **54** to hold the flexible circuit electrode array **2** to the retina. A stress relief **57** may be provided surrounding the attachment point **54**. The stress relief **57** may be made of a softer polymer than the flexible circuit, or it may include cutouts or thinning of the polymer to reduce the stress transmitted from the retina tack to the flexible circuit electrode array **2**. The flexible circuit cable **3** may be formed in a dog leg pattern so than when it is folded at fold **48** it effectively forms a straight flexible circuit cable **3** with a narrower portion at the fold **48** for passing through the sclerotomy. The electrode array **2** may comprise a polyimide cable that houses wire conductors and an array of exposed platinum electrodes in a grid. In one embodiment, there are sixty electrodes arranged in a 6×10 grid.

The electronics package **4** of FIGS. **2** and **3** can be electrically coupled to the inductive coil **116**. In one aspect, the inductive coil **116** contains a receiver and transmitter antennae made from wound wire. Alternatively, the inductive coil **116** may be made from a thin film polymer sandwich with wire traces deposited between layers of thin film polymer. The electronics package **4** may contain components and an Application Specific Integrated Circuit (ASIC) for processing the received data and using the received power to generate the required stimulation output. The electronics package **4** and the inductive coil **116** may be held together by a molded body **118** shown in FIG. **3**. As also shown in FIG. **3**, the molded body **118** may also include suture tabs **120** shown in FIG. **3**. The molded body narrows to form a strap **122** which surrounds the sclera and holds the molded body **118**, inductive coil **116**, and electronics package **4** in place. The molded body **118**, suture tabs **120** and strap **122** are preferably an integrated unit made of silicone elastomer. Silicone elastomer can be formed in a pre-curved shape to match the curvature of a typical sclera. Furthermore, silicone remains flexible enough to accommodate implantation and to adapt to variations in the curvature of an individual sclera. In one aspect, the inductive coil **116** and molded body **118** are oval shaped, and in this way, a strap **122** can better support the oval shaped coil.

The eye moves constantly. In one embodiment of the present disclosure, the entire retinal stimulation system **1** of the prosthesis is attached to and supported by the sclera of a subject. By placing the device under the rectus muscles with the electronics package in an area of fatty tissue between the

6

rectus muscles, eye motion does not cause any flexing which might fatigue, and eventually damage, the device.

FIG. **3** shows a side view of the retinal stimulation system **1**, in particular, emphasizing the fan tail **124**. When the retinal prosthesis is implanted, the strap **122** is passed under the eye muscles to surround the sclera. The inductive coil **116** and molded body **118** should also follow the strap under the lateral rectus muscle on the side of the sclera. The retinal stimulation system **1** of the visual prosthesis apparatus is very delicate. It is easy to tear the molded body **118** or break wires in the inductive coil **116**. In order to allow the molded body **118** to slide smoothly under the lateral rectus muscle, the molded body is shaped in the form of a fan tail **124** on the end opposite the electronics package **4**. Element **123** shows a retention sleeve, while elements **126** and **128** show holes for surgical positioning and a ramp for surgical positioning, respectively.

FIGS. **4** and **5** show front and side views of the Retinal stimulation system **1** implanted with respect to the subject's eye **7**. As shown in FIGS. **4** and **5**, the electrode array **2** enters the eye through a pars plana incision and is placed on the retina over the fovea using a retinal tack. The remaining Retinal stimulation system **1** is secured to the eye by means of a scleral band held in place by a Watzke sleeve (typical of scleral procedures), and also by suture tabs. Additionally, another suture may be placed around the scleral band in the inferior medical quadrant of the eye.

Referring to FIGS. **6A** and **7**, the glasses **5** may comprise, for example, a frame **11** holding a camera **12**, an external coil **14** and a mounting system **16** for the external coil **14**. The mounting system **16** may also enclose the RF circuitry. In this configuration, the video camera **12** captures live video. The video signal is sent to an external Video Processing Unit (VPU) **20** (shown in FIGS. **9-12** and discussed below), which processes the video signal and subsequently transforms the processed video signal into electrical stimulation patterns or data. The electrical stimulation data are then sent to the external coil **14** that sends both data and power via radio-frequency (RF) telemetry to the coil **116** of the retinal stimulation system **1**, shown in FIGS. **2** and **3**. The coil **116** receives the RF commands which control the application specific integrated circuit (ASIC) which in turn delivers stimulation to the retina of the subject via a thin film electrode array (TFEA). In one aspect of an embodiment, the video level corresponding to the image brightness is used to determine the stimulation values. The VPU **20** may use a logarithmic encoding scheme to convert the incoming light amplitudes into the electrical stimulation patterns or data. These electrical stimulation patterns or data may then be passed on to the Retinal Stimulation System **1**, which results in the retinal cells being stimulated via the electrodes in the electrode array **2** (shown in FIGS. **2**, **3** and **8**). In one exemplary embodiment, the electrical stimulation patterns or data being transmitted by the external coil **14** is binary data. The external coil **14** may contain a receiver and transmitter antennae and a radio-frequency (RF) electronics card for communicating with the internal coil **116**.

FIG. **6B** shows an exploded view of the external coil arrangement **14** and mounting system **16**. As also shown in FIGS. **6A** and **7**, the external coil arrangement **14** and mounting system **16** are connected by a flexible connector **1506**. In particular, the flexible connector **1506** is attached to RF coil enclosure halves **1507** and **1508** on the coil side and to enclosure case halves **1509** and **1510** on the mounting system side. The external coil arrangement **14** comprises coil enclosure halves **1507** and **1508**, enclosing printed circuit boards (PCB) **1511** and **1512** surrounding an RF transmitting coil **1513**. The PCBs **1511** and **1512** may further include telemetry receiving

coils. The mounting system **16** comprises case halves **1509** and **1510** enclosing an RF visor cable assembly **1514**. Other mechanical components shown in FIG. 6B include: wires **1515** connecting PCBs **1511** and **1512**; a mounting bracket **1516**; and RF circuitry **1501** located between case halves **1509** and **1510**. While video image processing is done in a VPU **20** (shown in FIGS. 11-12), the RF circuitry **1501** is incorporated into the mounting system **16** to reduce losses in the cable connecting the VPU **20** to the Glasses **5**. PCBs **1511** and **1512** can be made of glass base epoxy and laminated with copper. An exemplary circuit diagram of RF circuitry **1501** is shown in FIGS. 13-1 to 13-4.

Referring to FIG. 9, a Fitting System (FS) may be used to configure and optimize the visual prosthesis apparatus shown in FIG. 1. The Fitting System is fully described in the related application U.S. application Ser. No. 11/796,425, filed on Apr. 27, 2007, which is incorporated herein by reference in its entirety.

The Fitting System may comprise custom software with a graphical user interface running on a dedicated laptop computer **10**. Within the Fitting System are modules for performing diagnostic checks of the implant, loading and executing video configuration files, viewing electrode voltage waveforms, and aiding in conducting psychophysical experiments. A video module can be used to download a video configuration file to the Video Processing Unit (VPU) **20** discussed above and store it in non-volatile memory to control various aspects of video configuration, e.g. the spatial relationship between the video input and the electrodes. The software can also load a previously used video configuration file from the VPU **20** for adjustment.

The Fitting System can be connected to the Psychophysical Test System (PTS), located for example on a dedicated laptop **30**, in order to run psychophysical experiments. In psychophysics mode, the Fitting System enables individual electrode control, permitting clinicians to construct test stimuli with control over current amplitude, pulse-width, and frequency of the stimulation. In addition, the psychophysics module allows the clinician to record subject responses. The PTS may include a collection of standard psychophysics experiments and customized psychophysics experiments developed using external software tools like, for example, MATLAB (MathWorks) software and other tools to allow the clinicians to develop customized psychophysics experiment scripts.

Using the psychophysics module, important perceptual parameters such as perceptual threshold, maximum comfort level, and spatial location of percepts may be reliably measured. Based on these perceptual parameters, the fitting software enables custom configuration of the transformation between video image and spatio-temporal electrode stimulation parameters in an effort to optimize the effectiveness of the retinal prosthesis for each subject.

The Fitting System laptop **10** of FIG. 9 may be connected to the VPU **20** using an optically isolated serial connection adapter **40**. Because it is optically isolated, the serial connection adapter **40** assures that no electric leakage current can flow from the Fitting System laptop **10** in the even of a fault condition.

As shown in FIG. 9, the following components may be used with the Fitting System according to the present disclosure. The Video Processing Unit (VPU) **20** for the subject being tested, a Charged Battery **25** for VPU **20**, the Glasses **5**, a Fitting System (FS) Laptop **10**, a Psychophysical Test System (PTS) Laptop **30**, a PTS CD (not shown), a Communication Adapter (CA) **40**, a USB Drive (Security) (not shown), a USB Drive (Transfer) **47**, a USB Drive (Video Settings) (not

shown), a Patient Input Device (RF Tablet) **50**, a further Patient Input Device (Jog Dial) **55**, Glasses Cable **15**, CA-VPU Cable **70**, FS-CA Cable **45**, FS-PTS Cable **46**, Four (4) Port USB Hub **47**, Mouse **60**, Test Array system **80**, Archival USB Drive **49**, an Isolation Transformer (not shown), adapter cables (not shown), and an External Monitor (not shown).

With continued reference to FIG. 9, the external components of the Fitting System may be configured as follows. The battery **25** is connected with the VPU **20**. The PTS Laptop **30** is connected to FS Laptop **10** using the FS-PTS Cable **46**. The PTS Laptop **30** and FS Laptop **10** are plugged into the Isolation Transformer (not shown) using the Adapter Cables (not shown). The Isolation Transformer is plugged into the wall outlet. The four (4) Port USB Hub **47** is connected to the FS laptop **10** at the USB port. The mouse **60** and the two Patient Input Devices **50** and **55** are connected to four (4) Port USB Hubs **47**. The FS laptop **10** is connected to the Communication Adapter (CA) **40** using the FS-CA Cable **45**. The CA **40** is connected to the VPU **20** using the CA-VPU Cable **70**. The Glasses **5** are connected to the VPU **20** using the Glasses Cable **15**.

In one exemplary embodiment, the Fitting System shown in FIG. 9 may be used to configure system stimulation parameters and video processing strategies for each subject outfitted with the visual prosthesis apparatus of FIG. 1. The fitting application, operating system, laptops **10** and **30**, isolation unit and VPU **20** may be tested and configuration controlled as a system. The software provides modules for electrode control, allowing an interactive construction of test stimuli with control over amplitude, pulse width, and frequency of the stimulation waveform of each electrode in the Retinal stimulation system **1**. These parameters are checked to ensure that maximum charge per phase limits, charge balance, and power limitations are met before the test stimuli are presented to the subject. Additionally, these parameters may be checked a second time by the VPU **20**'s firmware. The Fitting System shown in FIG. 7 may also provide a psychophysics module for administering a series of previously determined test stimuli to record subject's responses. These responses may be indicated by a keypad **50** and or verbally. The psychophysics module may also be used to reliably measure perceptual parameters such as perceptual threshold, maximum comfort level, and spatial location of percepts. These perceptual parameters may be used to custom configure the transformation between the video image and spatio-temporal electrode stimulation parameters thereby optimizing the effectiveness of the visual prosthesis for each subject. The Fitting System is fully described in the related application U.S. application Ser. No. 11/796,425, filed on Apr. 27, 2007, which is incorporated herein by reference in its entirety.

The visual prosthesis apparatus of FIG. 1 may operate in two modes: i) stand-alone mode and ii) communication mode Stand-Alone Mode

Referring to FIGS. 1, 2 and 10, in the stand-alone mode, the video camera **12**, on the glasses **5**, captures a video image that is sent to the VPU **20**. The VPU **20** processes the image from the camera **12** and transforms it into electrical stimulation patterns that are transmitted to the external coil **14**. The external coil **14** sends the electrical stimulation patterns and power via radio-frequency (RF) telemetry to the implanted retinal stimulation system **1** (FIGS. 2 and 3). The internal coil **116** of the retinal stimulation system **1** receives the RF commands from the external coil **14** and transmits them to the electronics package **4** that in turn delivers stimulation to the retina via the electrode array **2**. Additionally, the retinal stimulation system **1** may communicate safety and operational status back to the VPU **20** by transmitting RF telemetry from the internal coil

116 to the external coil 14. The visual prosthesis apparatus of FIG. 1 may be configured to electrically activate the retinal stimulation system 1 only when it is powered by the VPU 20 through the external coil 14. The stand-alone mode may be used for clinical testing and/or at-home use by the subject. Communication Mode

The communication mode may be used for diagnostic testing, psychophysical testing, patient fitting and downloading of stimulation settings to the VPU 20 before transmitting data from the VPU 20 to the retinal stimulation system 1 as is done for example in the stand-alone mode described above. Referring to FIG. 9, in the communication mode, the VPU 20 is connected to the Fitting System laptop 10 using cables 70, 45 and the optically isolated serial connection adapter 40. In this mode, laptop 10 generated stimuli may be presented to the subject and programming parameters may be adjusted and downloaded to the VPU 20. The Psychophysical Test System (PTS) laptop 30 connected to the Fitting System laptop 10 may also be utilized to perform more sophisticated testing and analysis as fully described in the related application U.S. application Ser. No. 11/796,425, filed on Apr. 27, 2007, which is incorporated herein by reference in its entirety.

In one embodiment, the functionality of the retinal stimulation system 1 can also be tested pre-operatively and intra-operatively (i.e. before operation and during operation) by using an external coil 14, without the glasses 5, placed in close proximity to the retinal stimulation system 1. The coil 14 may communicate the status of the retinal stimulation system 1 to the VPU 20 that is connected to the Fitting System laptop 10 as shown in FIG. 9.

As discussed above, the VPU 20 processes the image from the camera 12 and transforms the image into electrical stimulation patterns for the retinal stimulation system 1. Filters such as edge detection filters may be applied to the electrical stimulation patterns for example by the VPU 20 to generate, for example, a stimulation pattern based on filtered video data that the VPU 20 turns into stimulation data for the retinal stimulation system 1. The images may then be reduced in resolution using a downscaling filter. In one exemplary embodiment, the resolution of the image may be reduced to match the number of electrodes in the electrode array 2 of the retinal stimulation system 1. That is, if the electrode array has, for example, sixty electrodes, the image may be reduced to a sixty channel resolution. After the reduction in resolution, the image is mapped to stimulation intensity using for example a look-up table that has been derived from testing of individual subjects. Then, the VPU 20 transmits the stimulation parameters via forward telemetry to the retinal stimulation system 1 in frames that may employ a cyclic redundancy check (CRC) error detection scheme.

In one exemplary embodiment, the VPU 20 may be configured to allow the subject/patient i) to turn the visual prosthesis apparatus on and off, ii) to manually adjust settings, and iii) to provide power and data to the retinal stimulation system 1. Referring to FIGS. 11 and 12, the VPU 20 may comprise a case 800, power button 805 for turning the VPU 20 on and off, setting button 810, zoom buttons 820 for controlling the camera 12, connector port 815 for connecting to the Glasses 5, a connector port 816 for connecting to the laptop 10 through the connection adapter 40, indicator lights 825 to give visual indication of operating status of the system, the rechargeable battery 25 for powering the VPU 20, battery latch 831 for locking the battery 25 in the case 800, digital circuit boards (not shown), and a speaker (not shown) to provide audible alerts to indicate various operational conditions of the system. Because the VPU 20 is used and operated by a person with minimal or no vision, the buttons on the VPU 20 may be

differently shaped and/or have special markings as shown in FIG. 12 to help the user identify the functionality of the button without having to look at it. As shown in FIG. 12, the power button 805 may be a circular shape while the settings button 820 may be square shape and the zoom buttons 820 may have special raised markings 830 to also identify each buttons functionality. One skilled in the art would appreciate that other shapes and markings can be used to identify the buttons without departing from the spirit and scope of the invention. For example, the markings can be recessed instead of raised.

In one embodiment, the indicator lights 825 may indicate that the VPU 20 is going through system start-up diagnostic testing when the one or more indicator lights 825 are blinking fast (more than once per second) and are green in color. The indicator lights 825 may indicate that the VPU 20 is operating normally when the one or more indicator lights 825 are blinking once per second and are green in color. The indicator lights 825 may indicate that the retinal stimulation system 1 has a problem that was detected by the VPU 20 at start-up diagnostic when the one or more indicator lights 825 are blinking for example once per five second and are green in color. The indicator lights 825 may indicate that the video signal from camera 12 is not being received by the VPU 20 when the one or more indicator lights 825 are always on and are amber color. The indicator lights 825 may indicate that there is a loss of communication between the retinal stimulation system 1 and the external coil 14 due to the movement or removal of Glasses 5 while the system is operational or if the VPU 20 detects a problem with the retinal stimulation system 1 and shuts off power to the retinal stimulation system 1 when the one or more indicator lights 825 are always on and are orange color. One skilled in the art would appreciate that other colors and blinking patterns can be used to give visual indication of operating status of the system without departing from the spirit and scope of the invention.

In one embodiment, a single short beep from the speaker (not shown) may be used to indicate that one of the buttons 825, 805 or 810 have been pressed. A single beep followed by two more beeps from the speaker (not shown) may be used to indicate that VPU 20 is turned off. Two beeps from the speaker (not shown) may be used to indicate that VPU 20 is starting up. Three beeps from the speaker (not shown) may be used to indicate that an error has occurred and the VPU 20 is about to shut down automatically. As would be clear to one skilled in the art different periodic beeping may also be used to indicate a low battery voltage warning, that there is a problem with the video signal, and/or there is a loss of communication between the retinal stimulation system 1 and the external coil 14. One skilled in the art would appreciate that other sounds can be used to give audio indication of operating status of the system without departing from the spirit and scope of the invention. For example, the beeps may be replaced by an actual prerecorded voice indicating operating status of the system.

In one exemplary embodiment, the VPU 20 is in constant communication with the retinal stimulation system 1 through forward and backward telemetry. In this document, the forward telemetry refers to transmission from VPU 20 to the retinal stimulation system 1 and the backward telemetry refers to transmissions from the Retinal stimulation system 1 to the VPU 20. During the initial setup, the VPU 20 may transmit null frames (containing no stimulation information) until the VPU 20 synchronizes with the Retinal stimulation system 1 via the back telemetry. In one embodiment, an audio alarm may be used to indicate whenever the synchronization has been lost.

In order to supply power and data to the Retinal stimulation system **1**, the VPU **20** may drive the external coil **14** with a 3 MHz signal. To protect the subject, the retinal stimulation system **1** may comprise a failure detection circuit to detect direct current leakage and to notify the VPU **20** through back telemetry so that the visual prosthesis apparatus can be shut down.

One exemplary embodiment of the VPU **20** is shown in FIGS. **13-1**, **13-2**, **13-3** and **13-4**. As shown in FIGS. **13-1**, **13-2**, **13-3** and **13-4**, the VPU **20** may comprise: a Power Supply, a Distribution and Monitoring Circuit (PSDM) **1005**, a Reset Circuit **1010**, a System Main Clock (SMC) source (not shown), a Video Preprocessor Clock (VPC) source (not shown), a Digital Signal Processor (DSP) **1020**, Video Preprocessor Data Interface **1025**, a Video Preprocessor **1075**, an I²C Protocol Controller **1030**, a Complex Programmable Logic device (CPLD) (not shown), a Forward Telemetry Controller (FTC) **1035**, a Back Telemetry Controller (BTC) **1040**, Input/Output Ports **1045**, Memory Devices like a Parallel Flash Memory (PFM) **1050** and a Serial Flash Memory (SFM) **1055**, a Real Time Clock **1060**, an RF Voltage and Current Monitoring Circuit (VIMC) **1071**, a speaker and/or a buzzer (not shown), an RF receiver **1065**, and an RF transmitter **1070**.

In one exemplary embodiment, the VPU **20** is a battery **25** powered micro-controller-based video processing and radio-frequency (RF) transceiver system. The VPU **20** may be comprised of a digital circuit for processing video from camera **12** (see FIG. **10**) and an RF circuit **1501**, shown in FIG. **13-1**, to facilitate 2-way communication with the retinal stimulation system **1**. In one exemplary embodiment, the RF circuit **1501** may be mounted in the enclosure **1510** on the visor/Classes **5** in close proximity to the retinal stimulation system **1** while the digital circuit of the VPU **20** can be remotely located in a case **800** shown in FIGS. **11A-E** and described below. The mechanical design, shown in FIG. **10**, may include a multiple-conductor cable **15** linking the VPU **20** and RF circuits **1501** disposed in the mounting system **16** as shown in FIGS. **6A** and **6B**. In another exemplary embodiment, the RF circuits **1501** may further comprise all the elements shown in FIGS. **13-1** to **13-4** that are disposed on the visor/Classes **5** in the mounting system **16**.

In an exemplary embodiment, the digital circuit of the VPU **20** accepts an incoming analog video stream from a small camera **12** mounted on the Glasses **5**, which may have the appearance of a pair of sunglasses. The analog video stream from the camera **12** is converted to a digital video stream by the Video Preprocessor **1075** of the VPU **20**. The digital video stream is then stored into memory as individual video frames typically by means of a direct memory access (DMA) circuit specifically designed to accept digital video, called the video preprocessor data interface (VDPI) **1025** shown in FIG. **13-4**. The VDPI **1025** of the VPU **20** processes the video frames stored in its memory into packets of stimulation information. The stimulation information is passed to the RF circuit **1501** via a serial port and an encoder circuit within the forward telemetry controller (FTC) **1035**. The RF transmitter circuit **1070** receives the stimulation information and transmits it to the retinal stimulation system **1** via a magnetically coupled coil **14**. The RF signal within the coil **14** has sufficient strength to power the retinal stimulation system **1**. The RF circuit **1501** is also capable of receiving back-telemetry information (containing status and safety related data) from the retinal stimulation system **1** via a coil connected to a receiver circuit **1065**. The received data is passed to a decoder circuit within the back telemetry controller (BTC) **1040** and then to a serial port, which allows the VDPI **1025** to examine the

received data. The power supply, distribution and monitoring circuit (PSDM) **1005** generates all of the appropriate voltages and contains a programmable power supply for the RF circuit **1501** to allow adjustment of the power level to the retinal stimulation system **1**.

The Power Supply, Distribution and Monitoring Circuit (PSDM) **1005** may regulate a variable battery voltage to several stable voltages that apply to components of the VPU **20**. The Power Supply, Distribution and Monitoring Circuit (PSDM) **1005** may also provide low battery monitoring and depleted battery system cutoff. The PSDM **1005** may be configured to provide Digital Circuit Voltage (VDD) $3.3\pm 0.1V@300\text{ mA}$; 300 mV ripple. The PSDM **1005** may be configured to provide DSP Core Voltage (CVDD1) $1.6\pm 0.1V@100\text{ mA}$; 200 mV ripple. The PSDM **1005** may be configured to provide CPLD Core Voltage (CVDD2) $1.8\pm 0.1V@50\text{ mA}$; 200 mV ripple. The PSDM **1005** may be configured to provide Analog Voltage (VA) $3.3\pm 0.1V@100\text{ mA}$; 300 mV ripple. The PSDM **1005** may be configured to provide Camera Voltage (V_{CAM}) $5.0\pm 0.25V@100\text{ mA}$; 300 mV ripple. The PSDM **1005** may be configured to provide RF Voltage 185 mV/step (V_{rf}) $4.75V-10.5V+0.3V@75\text{ mA}$; 300 mV ripple. The PSDM **1005** may be configured to provide Fixed Voltage (FV) $3.3\pm 0.1V@25\text{ mA}$; 100 mV ripple. In one exemplary embodiment, the RF voltage (V_{rf}) may be fused on the RF circuit as a failsafe mechanism to protect against excessive current in case of a malfunction.

In one exemplary embodiment, the VPU **20** stops providing power/data to the retinal stimulation system **1** and/or turns itself off when the PSDM **1005** detects that the battery **25**'s (FIG. **10**) voltage decreases to a predetermined voltage. The predetermined voltage may, for example, be 6.75 ± 0.4 volts. In one exemplary embodiment, the battery **25**'s voltage may be fused at the battery connector (not shown) as a fail-safe mechanism to protect against excessive current in case of malfunction. In another exemplary embodiment, the battery **25**'s drain current may be less than 1 mA when VPU **20** is turned off.

The Reset Circuit **1010** may have reset inputs **1011** that are able to invoke a system level reset. For example, the reset inputs **1011** may be from a manual push-button reset, a watchdog timer expiration, and/or firmware based shutdown. The manual push-button reset may be, for example, low active when pulse width is >1 ms. The watchdog timer reset may be activated when the watchdog timer is not reset within a predetermined expiration time, wherein the watchdog timer should be reset every 1.0 seconds or less if the expiration time ranges, for example, from 1.0 to 2.25 seconds. The firmware-based shutdown may be activated when the firmware evokes, for example, a falling edge signal.

The System Main Clock (SMC) source is a clock source for DSP **1020** and CPLD. The SMC may be, for example, $11.7846\text{ MHz}\pm 50\text{ ppm}$. The Video Preprocessor Clock (VPC) source is a clock source for the Video Processor and the VPC may be, for example, $24.576\text{ MHz}\pm 50\text{ ppm}$.

The DSP **1020** may act as the central processing unit of the VPU **20**. In one exemplary embodiment, the DSP **1020** is a Texas Instruments (TI) TMS 320VC5416PGE160. "TMS320VC5416PGE160 Fixed-Point Digital Signal Processor Data Manual" from TI is incorporated herein by reference. The DSP **1020** may communicate with the rest of the components of the VPU **20** through parallel and serial interfaces. The parallel interface of the DSP **1020** may create a Program Space (PS), a Data Space (DS) and Input/Output Space (IOS), wherein the executable code is allocated to PS, the data is allocated to the DS and I/O devices are allocated to IOS. The serial interface DSP **1020** may contain three Multi-

channel Buffered Serial Ports (McBSPs), wherein McBSP0 is configured in continuous clock mode for PC communication, McBSP1 is configured in non-continuous clock Serial Port Interface (SPI) mode for interface to the serial flash memory, and McBSP2 is configured in continuous clock mode for the RF transceiver.

The Video Processor **1075** may convert the NTSC signal from the camera **12** into a down-scaled resolution digital image format. In one exemplary embodiment, the Video Processor **1075** is a Philips Semiconductor SAA7114H. The Video Processor **1075** may comprise a video decoder (not shown) for converting the NTSC signal into high-resolution digitized image and a video scaler (not shown) for scaling down the high-resolution digitized image from the video decoder to an intermediate digitized image resolution. The video decoder of the Video Processor **1075** may be composed of an Analog Input Processing, Chrominance and Luminance Processing and Brightness Contrast and Saturation (BSC) Control circuits. The video scaler may be composed of Acquisition control, Pre-scaler, BSC-control, Line Buffer and Output Interface.

The I²C Protocol Controller **1030** may serve as a link between the DSP **1020** and the I²C bus. In one exemplary embodiment, the I²C Protocol Controller **1030** is a Philips Semiconductor PCA9564. The I²C Protocol Controller **1030** may be able to convert the parallel bus interface of the DSP **1020** to the I²C protocol bus or vice versa. The I²C Protocol Controller **1030** may also be connected to the Video Processor **1075** having, for example, a Read Address 43H and a Write Address 42H and the I²C Protocol Controller **1030** may be connected to the Real Time Clock **1060** wherein the clock control registers use, for example, read address ODFH and write address ODEH and wherein the EEPROM array uses, for example, read address OAFH and a write address OAEH.

The Complex Programmable Logic Device (CPLD) (not shown) furnishes the physical device for the multiple digital logic circuits. Memory space allocation: the executable code may be mapped to parallel flash memory device that is located at off-DSP space (PS 00000H~7FFFFH). The peripheral devices may be mapped to IOS as follows: Status/Timeport Port of the I²C communication device may be mapped to 2000H; Data Port of the I²C communication device may be mapped to 2001H; Own Address Port of the I²C communication device may be mapped to 2002H; and Control Port of the I²C communication device may be mapped to 2003H; Input port1 of the CPLD device may be mapped to 4000H; Inputport2 of the CPLD device may be mapped to 4001H; VideoDataInput of the CPLD device may be mapped to 4002H; CPLDVersion of the CPLD device may be mapped to 4003H; VideoLineCount of the CPLD device may be mapped to 4004H; OutputPort1 of the CPLD device may be mapped to 4008H; OutputPort2 of the CPLD device may be mapped to 400AH; OutputPort3 of the CPLD device may be mapped to 400BH; ADconvst of the CPLD device may be mapped to 6000H; ADCeN[1 . . . 0] of the CPLD device may be mapped to 8000~8003H; and KeypadInput of the CPLD device may be mapped to A000H.

The VPDI **1025** may contain a tri-state machine to shift video data from Video Preprocessor **1075** to the DSP **1020**. Signal ITRDY of the VPDI **1025** may be connected to Video Chip **1075** and DSP **1020** and may be used to indicate the status of shifting and to facilitate rapid response in transferring video data. In one exemplary embodiment, a high level signal ITRDY indicates to VPU **20** that VPDI **1025** is empty and ready to accept next data, and a low level signal ITRDY indicates to the VPU **20** that VPDI **1025** is full and the Video Preprocessor **1075** should hold in the Video Preprocessor

1075's internal FIFO (not shown). In one exemplary embodiment, the VPDI **1025** may have a coupling signal FreeVideo that enables or disables the VPDI **1025**'s functionality.

The Forward Telemetry Controller (FTC) **1035** of FIG. **13-1** may pack 1024 bits of forward telemetry data into a forward telemetry frame. The FTC **1035** retrieves the forward telemetry data from the DSP **1020**'s McBSP2 port and converts the data from logic level to biphase marked data. The FTC **1035** may generate BCLKX2 and BFSX2 signals to the DSP **1020**'s McBSP2 port. In one exemplary embodiment, the BCLKX2 signal may be a serial data clock for forward telemetry data and the BFSX2 signal may be an FX frame synchronization signal that may indicate that a first bit of each 16-bit word is generated by the serial part (McBSP2). To improve reliability of data transmission, the FTC **1035** may also convert a logic '1' to a double bit frequency signal and a logic '0' to a single bit frequency signal. In one exemplary embodiment, logic '1' may be converted to two (2) logic level transitions between the data clock signal (double frequency) and logic '0' may be converted to one (1) transition (single frequency). The word data in the DSP **1020** may be synchronized with the FTC **1035**'s counter through Frame Counter Starter (FCS) (not shown). The FTC **1035** may also have logic circuit for decoding a specific pattern of 1's and zeros (for example, 0100 1110 1010 0011) that indicate the beginning of a forward telemetry frame. As soon as the FTC **1035** receives a predefined word, FTC **1035**'s line counter begins to count down and is ready to accept the forward telemetry data. In one exemplary embodiment, the FTC **1035** may have an FTC reset functionality that causes the FTC **1035** to reset upon VPU **20**'s start up.

The Back Telemetry Controller (BTC) **1040** retrieves the biphase marked data from the RF receiver **1065**, decodes it, and generates the BFSR and bit clock (BCLKR) for the DSP **1020**'s McBSP2 interface. The BCLKR may be generated based on a decoded biphase marked data. In one exemplary embodiment, the biphase marked data may be received from the retinal stimulation system **1** and may be converted similarly to FTC **1035**. The Back Telemetry Controller (BTC) **1040** may also have a header detector (not shown) that monitors decoded data for predefined word header, for example, "1111111111111110." Upon detection of the predefined word header, a back telemetry word frame BFSR signal may be pulsed. If the BFSR signal occurs greater than 32 bits apart, an error bit may be set. The BFSR and BCLKR signal DSP **1020**'s McBSP2 port to receive data on the BDR2 input. The data rate on the BDR2 input may be 3.84±0.2 Kbps. Error bits may be set if the rate of modulation state change too fast or too slow.

The Input/Output Ports **1045** provide expanded JO functions to access the CPLD on-chip and off-chip devices. An InputPort1 (see Table 1) of the Input/Output Ports **1045** may have an address IOS 4000h and may provide off chip input access. An InputPort2 (see Table 2) of the Input/Output Ports **1045** may have an address IOS 4001h and may provide off chip input access. A VideoDataInput (see Table 3) of the Input/Output Ports **1045** may have an address IOS 4002h and may provide on chip input access. A CPLDVersion (see Table 4) of the Input/Output Ports **1045** may have an address IOS 4003h and may provide on chip input access. A VideoLineCount (see Table 5) of the Input/Output Ports **1045** may have an address IOS 4004h and may provide on chip input access. An OutputPort1 (see Table 6) of the Input/Output Ports **1045** may have an address IOS 4008h and may provide on chip and off chip output access. The initial value of the OutputPort1 may be 0000h at system reset. An OutputPort2 (see Table 7) of the Input/Output Ports **1045** may have an

15

address IOS 400Ah and may provide on chip output access. The initial value OutputPort2 may be 0001h at system reset. An ADconvst (see Table 8) of the Input/Output Ports 1045 may have an address IOS 6000h and may provide off chip output access. An ADCeN (see Table 9) of the Input/Output Ports 1045 may have an address IOS 8000H~8003H and may provide off-chip input access. An OutputPort3 (see Table 10) of the Input/Output Ports 1045 may have an address IOS 400Bh and may provide off-chip output access. The initial value of the OutputPort3 may be 0000h at system reset. A KeypadInput (see Table 11) of the Input/Output Ports 1045 may have an address IOS A000h and may provide off chip input access.

TABLE 1

InputPort1 Definition	
Bit	Function
0	Reserved
1	Frame Sync Slow Detect 1. 1 = Slow Frame Sync Detected (greater than 32 bits apart), 0 = Slow Frame Sync not detected. Write a zero to this bit or system reset to clear it.
2	Slow Modulation rate detect (greater than 348 usec per state). 1 = Slow modulation rate detected, 0 = Slow modulation rate not detected. Write a zero to bit 2 or bit 3 at this address or system reset to clear this bit.
3	Fast Modulation rate detect (between 43.5 and 87 usec per state). 1 = Fast modulation rate detected, 0 = Fast modulation rate not detected. Write a zero to bit 2 or bit 3 at this address or system reset to clear this bit.
4	Watchdog status. 1 = Watchdog timer has not expired. 0 = Watchdog timer has expired. This bit is set to the 1 state when the watchdog timer is subsequently reset.
5	0
6	0
7	0

TABLE 2

InputPort2 Definition	
Bit	Function
0	CA detection. 1 = CA connection is detected, 0 = CA connection is not detected.
1	Low Battery Detection. 1 = Normal battery voltage, 0 = Low Battery is detected.
2	Reserved
3	Connect Verify. 1 = Camera/RF connector not connected, 0 = Camera/RF connector connected.
4	Utility Key 8. 0 = Key not depressed, 1 = Key depressed
5	Program/Run Switch Position. 1 = Switch in Program position, 0 = Switch in Run position.
6	Reserved
7	Reserved

TABLE 3

VideoDataInput Definition	
Bit	Function
0~7	Video data input port

16

TABLE 4

CPLD_Version Definition	
Bit	Function
0~7	CPLD Version number, 8 bits

TABLE 5

VideoLine Count Definition	
Bit	Function
0~7	NTSC line counter. An 8-bit counter to count the NTSC line

TABLE 6

OutputPort1 Definition	
Bit	Function
0~4	RF power control. 00000 = 4.75 +/- 0.3 V, 11111 = 10.5 +/- 0.3 V
5	System Running LED Indicator. 1 = turn the System Running LED on, 0 = turn the System Running LED off.
6	RF Link LED Indicator. 1 = turn the RF Link LED on, 0 = turn the RF Link off.
7	Camera Disconnect LED Indicator. 1 = turn the LED on, 0 = turn the LED off

TABLE 7

OutputPort2 Definition	
Bit	Function
0	freeVideo, the VPDI coupling signal. 1 = VPDI is disabled, 0 = VPDI is enabled
1~2	Reserved
3	Shutdown, normally 0, set to 1 for at least 1 msec and then back to 0 to force a system shutdown
4	Reserved
5~6	Forward Telemetry BFSX signal start signal, 11 = command the BFSX to generate the word frame signal, 00 = no BFSX word frame signal. May be changed from 00 to 11 within one system bus cycle
7	Carrier enable. 1 = enable the carrier clock to the RF circuit and the BCLK to McBSP2, 0 = disable carrier clock and BCLK which are forced to output a low signal state

TABLE 8

ADconvst Definition	
Bit	Function
0~7	AD converter sampling start trigger signal. Access of this port does not cause any data transfer between DSP, CPLD and AD converter. A low-active 50-300 nsec pulse from a dummy read access is used to trigger the AD converter to sample the signal

TABLE 9

ADCeN Definition		
Address	Bit	Function
8000H	0~7	Read present A/D data and select Channel 1 (the Vrf current) for the subsequent A/D sample. Each count for channel 1 data may represent 2.35 mA; the range may be 0 to 602 mA

TABLE 9-continued

ADCeN Definition		
Address	Bit	Function
8001H	0~7	Read present A/D data and select Channel 2 (the Vrf voltage) for the subsequent A/D sample. Each count for channel 2 data may represent 43.32 mV; the range may be 0 to 11.05 V
8002H	0~7	Reserved
8003H	0~7	Reserved

TABLE 10

OutputPort3 Definition	
Bit	Function
0	A/D converter power up/down, 0 = power down, 1 = power up
1	Vrf control, 0 = Vrf powered off, 1 = Vrf powered on
2	Watchdog counter reset signal. The watchdog counter is reset when the state of this bit is changed
3~5	Reserved
6	Buzzer control, 1 = turn the buzzer on, 0 = turn the buzzer off
7	Reserved

TABLE 11

KeypadInput Definition	
Bit	Function
0	Utility Key 0. 1 = Key not depressed, 0 = Key depressed
1	Utility Key 1. 1 = Key not depressed, 0 = Key depressed
2	Utility Key 2. 1 = Key not depressed, 0 = Key depressed
3	Utility Key 3. 1 = Key not depressed, 0 = Key depressed
4	Utility Key 4. 1 = Key not depressed, 0 = Key depressed
5	Utility Key 5. 1 = Key not depressed, 0 = Key depressed
6	Utility Key 6. 1 = Key not depressed, 0 = Key depressed
7	Utility Key 7. 1 = Key not depressed, 0 = Key depressed

In one exemplary embodiment, the buzzer (Table 10) may be from Soberton Inc. part number ST-03BL audio buzzer that operates at 2.3 KHz. The buzzer may provide a sound pressure level of 68-82 dB at 5 cm distance without an enclosure.

The VPU 20 shown in FIGS. 11-12 and 13-1-13-4 may have attachable/detachable ports 815-816 shown in FIGS. 11-12 to connect several peripheral units. The connectors are classified as functional connectors, e.g. port 815 and development connectors. The functional connectors link the functional peripheral devices, for example, Glasses 5 of FIG. 6 to the VPU 20 to furnish a production level function for the system. The development connectors may be used when the system is under development phase.

The Power Connector 821 shown in FIGS. 11F-11G (connector under the battery 25 in FIG. 11A) is a functional connector that connects the battery 25 to the VPU 20.

Port 815 is a functional Camera/RF Connector. Port 815 may contain 12 pins (identified in Table 12 below) to provide connection for the camera 12 and external coil 14 on the Glasses 5. The port 815 may be protected such that port 815 will withstand an indefinite short to the camera 12's power. The power connector and the port 815 may be mechanically keyed to prevent improper installation.

TABLE 12

Camera/RF Connector Pin Definition			
Pin	Name	Type	Function
5	1 Vrf	Power	RF voltage source
	2 RF_GND	Power	Ground return for RF voltage source
	3 BK_TEL	Input	Back Telemetry Data from RF Board
	4 Carrier	Output	Carrier signal to RF Board
	5 Data	Output	Forward Telemetry data to RF Board
10	6 Connect	Input	Status pin for verification of Camera/RF connection
	7 DGND	Power	Ground return for signals on pin 3 through 6 and pin 8
	8 Equip Sync	Output	
15	9 Camera	Power	Power for the camera. Equal to the battery voltage, and is switched off when the system power supplies are shut down
	10 AGND	Power	Ground return for camera power
	11 Video In	Input	Video input from the camera
	12 AGND	Power	Ground return for the camera video
20			

The Parallel Flash Memory (PFM) 1050 may be used to store executable code and the Serial Flash Memory (SFM) 1055 may provide Serial Port Interface SPI for data storage. The PFM 1050 may be implemented using, for example, Intel TE28F160B3TD70. The PFM 1050 is connected to the address and data bus. The PFM may contain 512K words to map to an executable code space (PS) of the DSP 1020. A user-selectable switch (not shown) may be provided to enable or disable writing to the PFM 1050. The SFM 1055 may be implemented using, for example, STMicroelectronics M25P80. The SFM 1055 may contain 16 independently erasable sectors, with each sector containing, for example, 64K bytes.

The Real Time Clock 1060 may be battery backed up real time clock that is connected to the I2C bus. The Real Time Clock 1060 may be implemented using, for example, Xicor X1226 that uses a 32.768 KHz crystal and draws 600 nA from a 48 mAH primary lithium cell to keep the clock running when the VPU 20 is powered off. The Real Time Clock 1060 may contain 512 bytes of flash EEPROM which may be programmed or read via the I2C bus.

The VIMC 1071 may be used to monitor the integrity status of the retinal stimulation system 1 by sampling and monitoring RF transmitter 1070's current and voltage. The RF transmitter 1070's current may be converted to voltage through a current sensitive resistor (not shown) of 100 mohm+/-2%. The voltage drop across the sensitive resistor is amplified by a current shunt monitor to 0~2.0V of dynamic range. The voltage is buffered for AD converting. Vrf may also be sent through a resistor divider for AD converting. The AD converter may have resolution of 8 bits with a signal input range of 0~2V. The conversion accuracy of the AD converter for measuring RF transmitter current and Vrf may be, for example, ±3.6%.

Four external interrupt signals INT0 through INT3 may be input to the DSP 1020. The INT0 may have the highest priority and INT3 may have the lowest. The INT0 may be connected to the vertical sync output of the Video Preprocessor 1075 to signal the start of a new video frame. The INT1 may be connected to the Keypad interface of the IOP 1045 to signal when a key is depressed or released. The INT2 may be optional. The INT3 may be connected to signal ITRDY of the VPDI 1025.

Port 816 of FIGS. 11A-E is an Omnetics Connector that is used to connect the VPU 20 to the laptop 10 though the

Communication Adapter (CA) **40** of FIG. **9**. The Omnetics Connector may have 10 pins (identified in Table 13 below).

TABLE 13

Omnetics Connector Pin Definition			
Pin	Name	Type	Function
1	Transmit Data	Output	Transmit data to CA 40
2	Vcc	Input	+3.3 V for power to VPU side of CA opto-isolators
3	Ground	Power	Ground connection to CA
4	DataCLK	Output	Data clock from CA
5	Receive Data	Output	Received data from CA
6	N/C	Input	No connection
7	FSR	Input	Frame Sync for receive data from CA
8	Connect Verify		Line to verify connection of the CA (low = connected, float = not connected)
9	N/C		No connection
10	N/C		No connection

Keypad Connector is a 14-conductor flat connector for in-system keypad and LED connection.

The following are examples of Development Connectors according to one exemplary embodiment of the present application. □A Programmable Logic Download Connector is a development connector for downloading the .jed file from Xilinx WebPack to on-board CPLD. The Programmable Logic Download Connector is compliant to JTAG, which is the commonly used acronym for the Boundary Scan Test (BST) feature defined for integrated circuits by IEEE Standard 1149.1. This standard defines input/output pins, logic control functions, and commands that facilitate both board and device level testing without the use of specialized test equipment. A DSP JTAG Connector is a development connector for linking the digital board to the DSP **1020** development system—Code Composer Studio. The DSP JTAG Connector is compliant to IEEE standard 1149.1. A Equipment Sync is a signal that is available through the Camera/RF connector port **815**. The Equipment Sync provides a pulse (width 1 ms, positive going and 3.3V amplitude) to indicate that the first 16-bit word of a 1024 bit packet is being output by the forward telemetry logic.

The power button **805** of FIG. **12** may be used for turning the VPU **20** on/off. In one exemplary embodiment, the power button **805** may be depressed for a predetermined amount of time (for example 1.6±0.2 seconds) before the VPU **20** actually powers up. In another exemplary embodiment, the power button **805** may be depressed for another predetermined amount of time (for example 1.6±0.2 seconds) before the VPU **20** actually powers down.

In one exemplary embodiment, a CMOS sensor **1073** that provides digital output may be used instead of the camera **12** as shown in FIGS. **14-1** to **14-4**. The CMOS sensor **1073** may have within it, or be connected to a high-speed digital serial transmitter circuit such as one using the Low Voltage Differential Signal (LVDS) protocol. This serial data may be passed through the multi-conductor cable to an LVDS receiver **1072**, which would be used in place of the video decoder circuit **1075**. The receiver **1072** may perform serial-to-parallel conversion of the video data and thus provide the digital video stream to the VDPI circuit **1025**. This embodiment may allow for elimination of the video decoder and may allow better control of the CMOS sensor **1073** via the programmable registers available within CMOS sensor **1073**.

Due to the nature of the video data being processed, it may be advantageous to use a digital signal processor (DSP) **1020** for micro-controller. DSPs **1020** are more adept at applying digital filtering algorithms to the incoming video frames. For functions such as real-time control of the voltage to the RF circuit **1501** or handling the user interface, however, it is easier to program a general-purpose micro-controller (such as the ARM). It may be possible to use a so-called “dual core” device containing both an ARM (or other general purpose micro-controller) and a DSP. Each processor may be assigned to handle the functions they best serve. To save space, it may be possible to select a micro-controller that has the VDPI **1025** circuit built into it.

In an alternate embodiment, instead of implanting a retinal stimulation system **1** into the subject's eye as shown in FIGS. **2-5** and described above, an implantable visual prosthesis may be used to directly stimulate the visual cortex of the brain as shown in FIG. **15**. For example, an electrode array **102** may be placed in the calcarine fissure of the primary visual cortex. The central 20 degrees of primary visual cortex falls near the calcarine cortex, but the location and shape of the calcarine varies considerably, extending significantly onto the ventral and lateral surface of some subjects and less so in others. The cortical representation in the left hemisphere maps to the right visual field (i.e. to the right side of the vertical meridian), and vice versa. □The implantable visual prosthesis contains an inductive coil **117**, that is similar to the coil **116** described above, and an electrode array **102**, that is electrically coupled by a cable **103** that is similar to cable **3** described above, to an electronics package **104**, that is similar to the electronics package **4** described above. The Electronics package **104** and inductive coil **117** may be disposed on the outer surface of the brain within a tunneled portion of the skull. This allows the inductive coil **117** to receive data and power from a coil (not shown) external to the body.

FIG. **16** shows the projection of an object in the external world onto the surface of the retina. An image **1402** in FIG. **16** is focused and inverted by the eye **1405** and projected on the retina **1406**. Each area of the retina **1406** is mapped to a direction in the field vision. A section of the retina can be mapped to the corresponding field of view in the external world. The field of view is an angle because a given area on a retina relates to a small object up close or a very large object, far away.

Human vision provides a field of view that is wider than it is high. This is partially due to fact that people have two eyes, but even a single eye provides a field of view that is approximately 90° high and 140° to 160° degrees wide. Although a single degree of the field of view relates to approximately 0.29 mm to 0.33 mm area of the retina **1406**, the actual size of the area of the retina **1406** that relates to a single degree of the field of view depends on the physical size of the subject's eye. The details of how to calculate a visual angle are further disclosed on page 96 from The Human Eye, Structure and Function Clyde W. Oyster; Sinauer Associates, Sunderland, Mass., 1999, ISBN 0-87893-645-9 reproduced herein in Appendix A.

In a visual prosthesis, as shown in FIGS. **17-18**, an electrode array **2** implanted in the eye **1411** covers a portion of the retina **1412**. The camera **12** mounted in glasses **5**, shown in FIGS. **6A** and **7**, collects the image **1402** as shown in FIG. **17-18**. Since the camera **12** may have a different focal length than the eye **1411**, the camera **12** presents a different view than the eye **1411** naturally sees. It is advantageous to, as much as possible, match the stimulation of the retina **1412** by the electrode array **2** to the part of the image that would normally be projected onto this part of the retina. Since, the

resolution of the camera **12** is greater than with the exemplary electrode array **2**, the field of view matching may be accomplished either optically or electronically as shown below.

Matching the field of view of the input video image to the field of view subtended by an implant is important for maintaining the spatial relationship between where the camera is pointed and where the electrically stimulated phosphenes appear in the world. For example, if the subject turns their head (and therefore the head-mounted camera) 45 degrees left, it is important to know that an object coming into view is 45 degrees to the left from where the subject was originally pointed. If the field of view of the camera is not matched to the field of view of the implant, there will be a change in system magnification that will shift the position of objects in the world such that their perceived location (generated by retinal stimulation) is not aligned with their actual position in the external world. Another reason for matching the field of view is to reduce the tendency for motion sickness. Motion sickness is caused by a mismatch between sensory input from different modalities, such as the vestibular system and the visual system. If the field of view of the implant is not matched to the camera, movements of the camera will produce image motion that is either faster or slower than it would be under natural conditions. Users of video systems for the visually impaired, such as the JORDY and LVES, have reported that this unpleasant sensation is minimized when the fields of view of the camera and the display device are matched.

In one exemplary embodiment, the electrode array **2** may comprise an array of sixty exposed platinum electrodes arranged in a 6x10 grid as shown in FIG. **18**. The electrodes in the electrode array **2** may have a diameter of about 200 μm to about 210 μm . In this exemplary embodiment, the electrode array **2** may be about 3.15 mm high and about 5.25 mm wide, wherein a distance of about 525 μm (center to center) may separate the electrodes of the electrode array **2**. If a single degree of the field of view in a healthy eye **1405** relates to approximately about 0.293 mm area of the retina **1406**, the electrode array **2**, in the present exemplary embodiment, implanted in the eye **1411** may provide a span of about (3.15 mm)*(1 degree/0.293 mm)=10.8 degrees of visual angle in the vertical direction and a span of about (5.25 mm)*(1 degree/0.293 mm)=17.9 degrees of visual angle in the horizontal direction. Because the actual size of the area of the retina **1411** that relates to a single degree of the field of view depends on the actual physical dimensions of the eye **1411**, in one exemplary embodiment, the electrode array **2** implanted in the eye **1411** may be adjusted to provide a visual angle that corresponds to the actual physical dimensions of the eye **1411**. Furthermore, as can be seen from the above, the visual angle of the eye **1411** will increase as the electrode array **2** increases in size and the number of electrodes.

As disclosed above and shown in FIGS. **12** and **11B**, the three zoom buttons **820** of the VPU **20** may be used to control the camera **12**. In an exemplary embodiment, two of the buttons **820** may be used as a zoom-in and zoom-out buttons to change the visual angle of the camera **12**, while the third button **820** may be used to automatically adjust the zoom of the camera **12** to a default zoom so as to provide a default span of about 10.8 degrees by about 17.9 degrees of visual angle to the eye **1411**. As can be seen from the above, the default zoom of the camera **12** depends on the size of the electrode array **2** and will increase as the electrode array **2** increases in size and the number of electrodes.

In one exemplary embodiment, the two zoom buttons **820**, that are used as zoom-in and zoom-out buttons, are configured to zoom-in and zoom-out in fixed step increments. For

example, by activating one of the zoom button **820**, a user may activate a reading mode wherein the camera **12** automatically doubles the size of the image presented to the subject by capturing an area half the size in the video image and stretching it to cover the stimulating array **12**. In another example, by activating another zoom button **820**, a user may activate a wide field of view mode wherein the camera **12** automatically doubles the size of the image being captured by the camera **12** and presenting this squeezed image to the stimulating array. The user may, for example, use the wide field of view mode to monitor for traffic in his or her peripheral vision before crossing the road.

As described above, the Video Processor **1075**, shown in FIG. **13-4**, of the VPU **20** may convert the NTSC signal from the camera **12** into a digital scaled-down resolution image. The Video Processor **1075** may be configured to down-scale the image from camera **12** to provide a span of about 10.8 degrees by about 17.9 degrees of visual angle once the third button **820** is activated to the default setting by a subject and/or a clinician. The VPU **20** and the electrode array **2** may provide a span of about 10.8 degrees by about 17.9 degrees of visual angle as a default setting upon activation of the VPU **20**. As can be seen from the above, the default setting depends on the size of the electrode array **2** and will increase as the electrode array **2** increases in size and the number of electrodes.

It should be noted that the present disclosure is not limited to a retinal electrode array. Other methods of stimulating visual neurons, such as stimulating the visual cortex operate on the same principle. An electrode array on the visual cortex still relates to a given field of view that can be matched by the visual prosthesis.

The following concepts are supported by the present application:

Concept 1. A visual prosthesis apparatus comprising:

- a video capture device for capturing a video image;
- a video processing unit associated with the video capture device, the video processing unit configured to convert the video image to stimulation patterns; and
- a stimulation system configured to stimulate subject's neural tissue based on the stimulation patterns,

wherein the stimulation system provides a span of visual angle matched to the subject's neural tissue being stimulated.

Concept 2. The visual prosthesis apparatus of Concept 1, wherein the stimulation system is a retinal stimulation system.

Concept 3. The visual prosthesis apparatus of Concept 1, wherein the stimulation system is a visual cortex stimulation system.

Concept 4. The visual prosthesis apparatus of Concept 1, wherein the video processing unit comprises a video processor configured to convert the video image into a digital scaled-down resolution image format before the video processing unit generates the stimulation patterns.

Concept 5. The visual prosthesis apparatus of Concept 1, wherein the field of view is wider than it is high.

Concept 6. The visual prosthesis apparatus of Concept 1, wherein the span of the visual angle is about 10.8 degrees by about 17.9 degrees.

Concept 7. The visual prosthesis apparatus of Concept 1, wherein the retinal stimulation system provides for alternate spans of visual angle and returns to a span of visual angle matched to the subject's stimulated neural tissue once a button associated with the video processing unit is activated.

Concept 8. The visual prosthesis apparatus of Concept 7, wherein the alternate spans of visual angle are continuously

controllable, and a single action returns the apparatus to span of visual angle matched to the neural tissue stimulated in the subject's eye.

Concept 9. The visual prosthesis apparatus of Concept 1, wherein the retinal stimulation system provides the span of visual angle matched to the subject's stimulated neural tissue once the video processing unit and/or the video capture device are activated.

Concept 10. A method for determining a field of view of an electrode array implanted on a subject's retina, the method comprising:

- determining physical dimensions of a subject's eye;
- providing an electrode array; and
- calculating a field of view of the area of the retina stimulated by the electrode array based on the physical dimensions of the subject's eye and dimensions of the electrode array

Concept 11. The method of Concept 6, wherein the field of view of the electrode array is about 10.8 degrees by about 17.9 degrees when the size of the area of the retina stimulated by the electrode array is about 3.15 mm high and about 5.25 mm wide.

Concept 12. A method for stimulating a subject's eye, the method comprising:

- capturing a video image;
- converting the video image to stimulation patterns; and
- stimulating subject's neural tissue based on the stimulation patterns,

wherein the stimulation patterns provide a span of about 10.8 degrees by about 17.9 degrees of visual angle to the subject's stimulated neural tissue.

Concept 13. A method for determining a field of view of an electrode array implanted on a subject's retina, the method comprising:

- determining a vertical length and a horizontal length of the subject's neural tissue being stimulated by stimulation patterns;
- determining a vertical visual angle of an electrode array by multiplying the vertical length by (1 degree/0.293 mm); and
- determining a horizontal visual angle of the electrode array by multiplying the horizontal length by (1 degree/0.293 mm).

Concept 14. A video processing unit comprising:

- a zoom-in button;
- a zoom-out button; and
- a default zoom button,

wherein a video capture device associated with the video processing unit provides a default zoom when the default zoom button is activated, wherein the video capture device doubles the size of the default zoom when the zoom-in button is activated, and wherein the video capture device provides half the default zoom when the zoom-out button is activated.

As used in this specification and the appended claims, the singular forms "a," "an," and "the" include plural referents unless the content clearly dictates otherwise. The term "plu-

rality" includes two or more referents unless the content clearly dictates otherwise. Unless defined otherwise, all technical and scientific terms used herein have the same meaning as commonly understood by one of ordinary skill in the art to which the disclosure pertains.

Accordingly, what has been shown is an improved visual prosthesis, improved method of stimulating neural tissue and an improved method for controlling a visual prosthesis. While the invention has been described by means of specific embodiments and applications thereof, it is understood that numerous modifications and variations could be made thereto by those skilled in the art without departing from the spirit and scope of the invention. It is therefore to be understood that within the scope of the claims, the invention may be practiced otherwise than as specifically described herein.

What is claimed is:

1. A visual prosthesis comprising:

- a neural stimulation system adapted to contact and stimulate a subject's visual neural tissue and subtending a portion of the subject's visual neural tissue;
- a video capture device providing a video image; and
- a video processing unit receiving the video image from the video capture device, selecting a portion of the video image having a field of view matching a field of view of the subject's neural tissue subtended by the neural stimulation system, converting the portion of the video image to stimulation patterns and transmitting the stimulation patterns to the neural stimulation system.

2. The visual prosthesis according to claim 1, further comprising means for adjusting the field of view of the stimulation patterns with an indication of a default zoom when the field of view matches the field of view subtended by the neural stimulation system.

3. The visual prosthesis according to claim 2, wherein the field of view of the stimulation patterns is continuously controllable, and a single action returns the field of view of the stimulation patterns to the field of view matched to the visual neural tissue subtended by the neural stimulation system.

4. The visual prosthesis according to claim 1, wherein the field of view is an angle between 10 and 12 degrees by between 17 and 19 degrees.

5. The visual prosthesis according to claim 4, wherein the field of view is about 10.8 degrees by about 17.9 degrees of visual angle to the subject's stimulated visual neural tissue.

6. The visual prosthesis according to claim 1, wherein the visual neural tissue is a retina.

7. The visual prosthesis apparatus of claim 2, wherein the field of view of the stimulation patterns matches the field of view subtended by the neural stimulation system once the video processing unit and/or the video capture device are activated.

* * * * *