



US 20170124756A1

(19) **United States**

(12) **Patent Application Publication**
DAZÉ

(10) **Pub. No.: US 2017/0124756 A1**

(43) **Pub. Date: May 4, 2017**

(54) **METHODS AND SYSTEMS FOR GENERATING DYNAMIC USER INTERFACE EFFECTS**

(71) Applicant: **FARADAY&FUTURE INC.**, Gardena, CA (US)

(72) Inventor: **Nicholas William DAZÉ**, Los Angeles, CA (US)

(73) Assignee: **FARADAY&FUTURE INC.**, Gardena, CA (US)

(21) Appl. No.: **15/336,853**

(22) Filed: **Oct. 28, 2016**

Related U.S. Application Data

(60) Provisional application No. 62/248,485, filed on Oct. 30, 2015.

Publication Classification

(51) **Int. Cl.**
G06T 15/60 (2006.01)
G06F 3/0346 (2006.01)
G06F 3/0488 (2006.01)
G06T 15/50 (2006.01)
G06F 3/03 (2006.01)

(52) **U.S. Cl.**
 CPC *G06T 15/60* (2013.01); *G06T 15/506* (2013.01); *G06F 3/0325* (2013.01); *G06T 15/503* (2013.01); *G06F 3/04883* (2013.01); *G06F 3/0346* (2013.01); *G06T 2200/24* (2013.01)

(57) **ABSTRACT**

A method of generating dynamic user interface effects may include receiving positioning data indicative of a location of the user interface and receiving orientation data indicative of an orientation of the user interface. The method may also include determining a location of a light source relative to the user interface based on the positioning data and the orientation data, and modifying an image on the user interface based on the location of the light source.

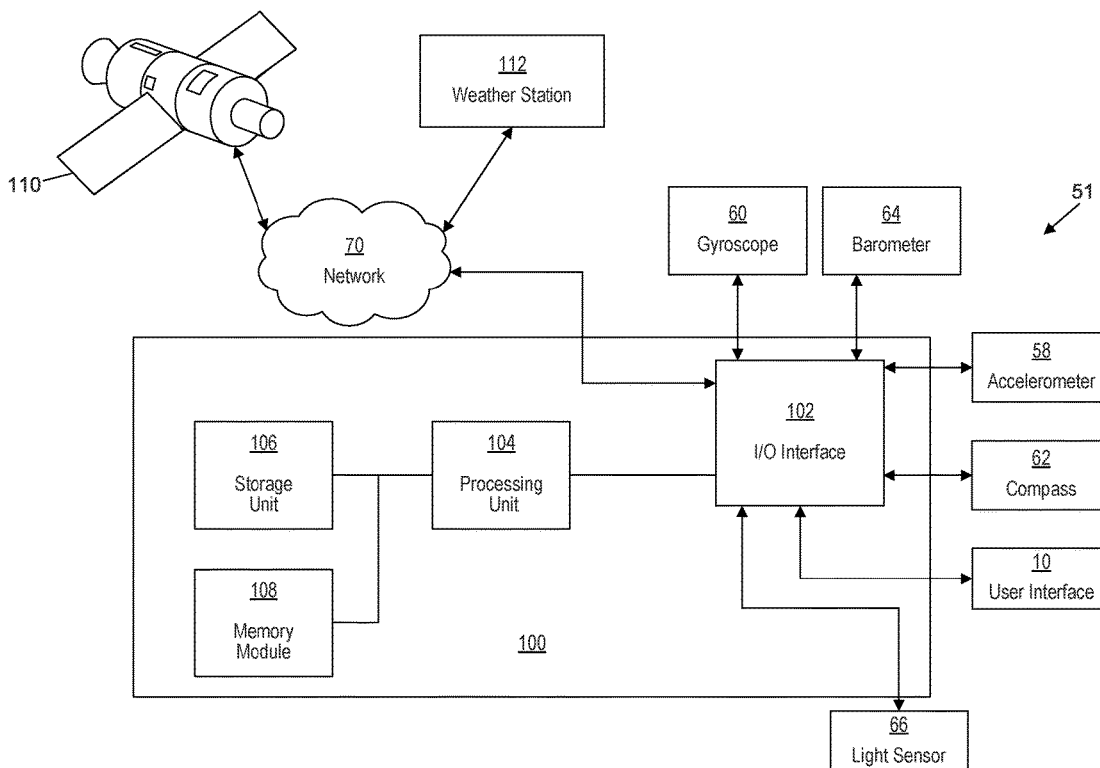

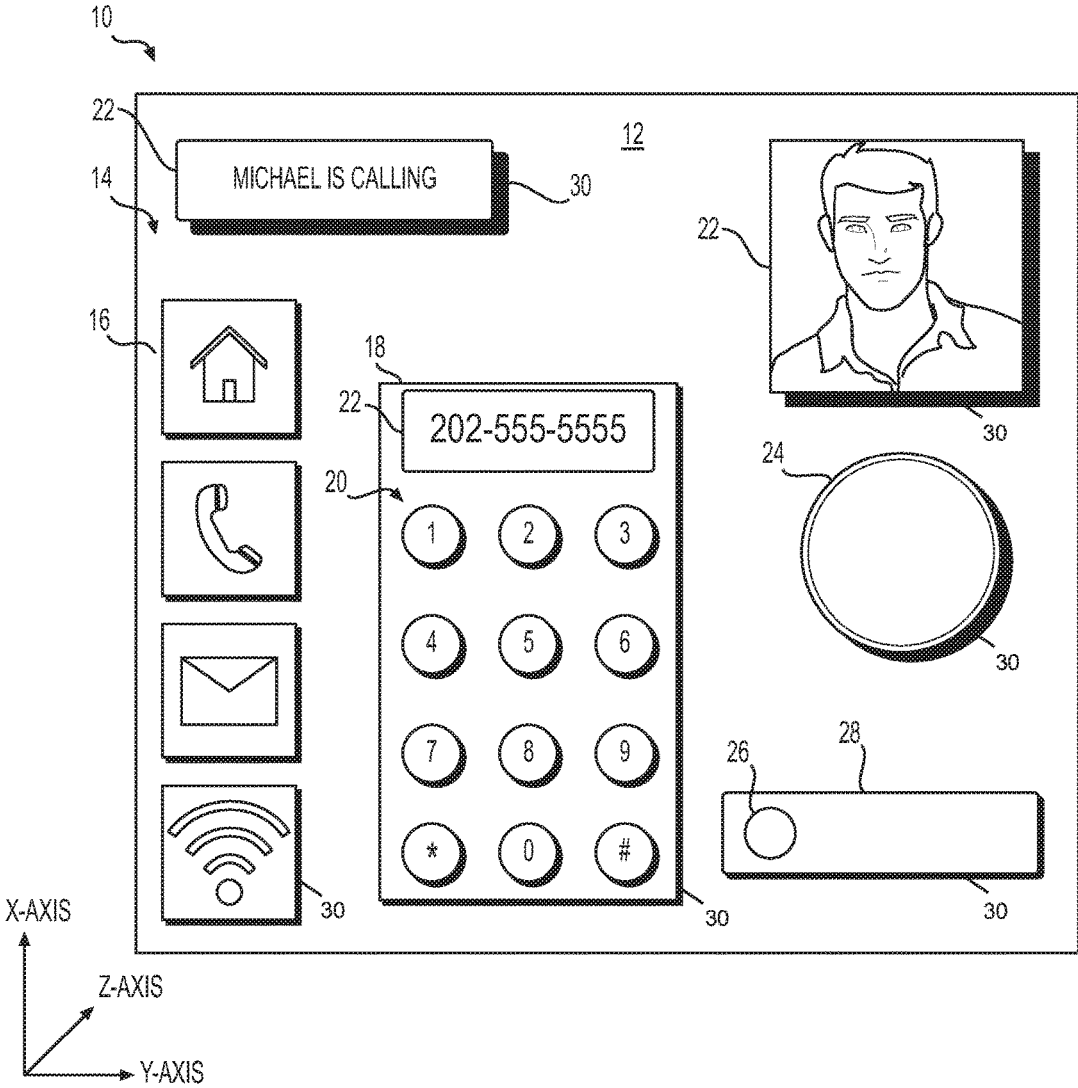

FIG. 1

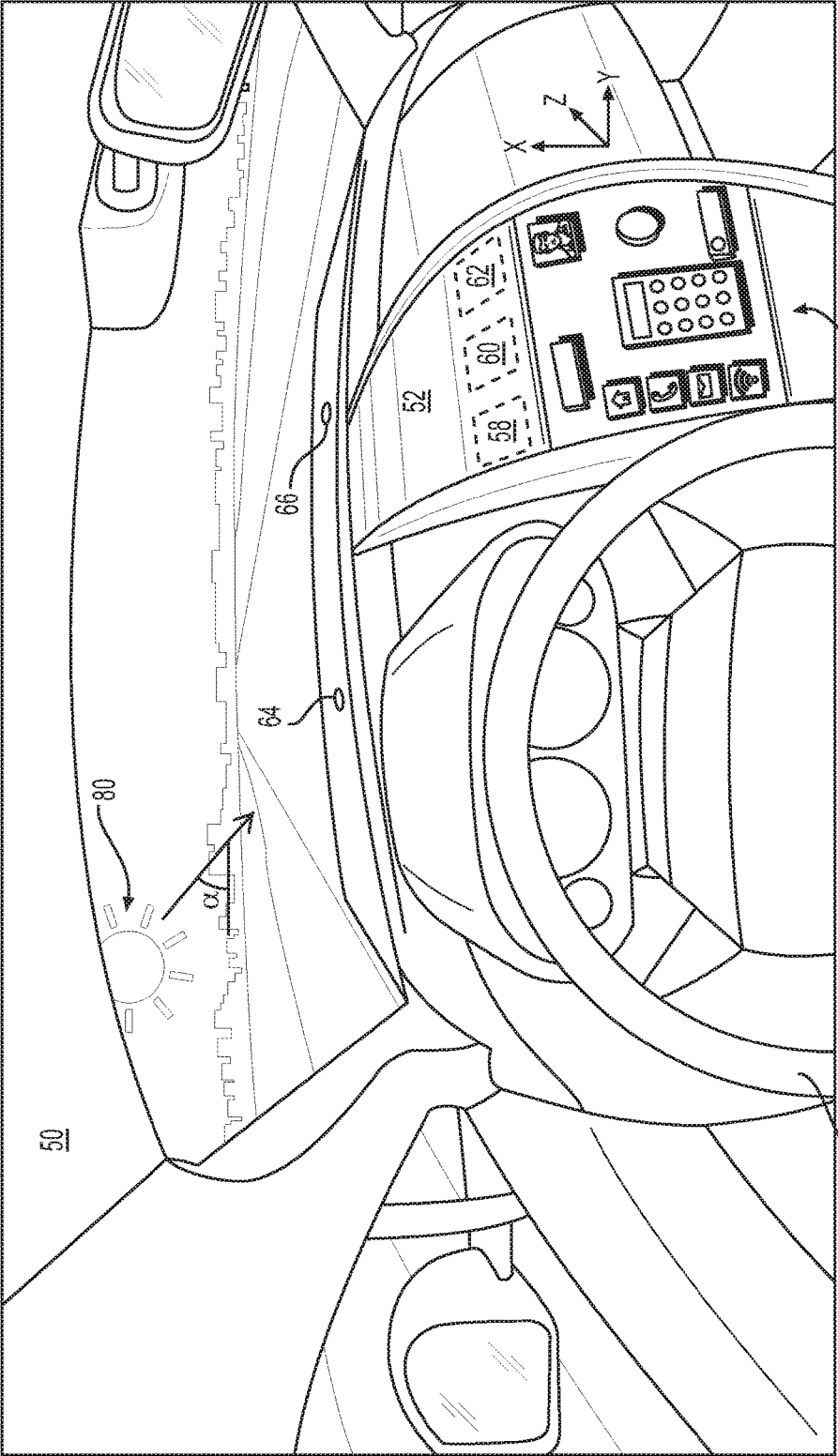

FIG. 2

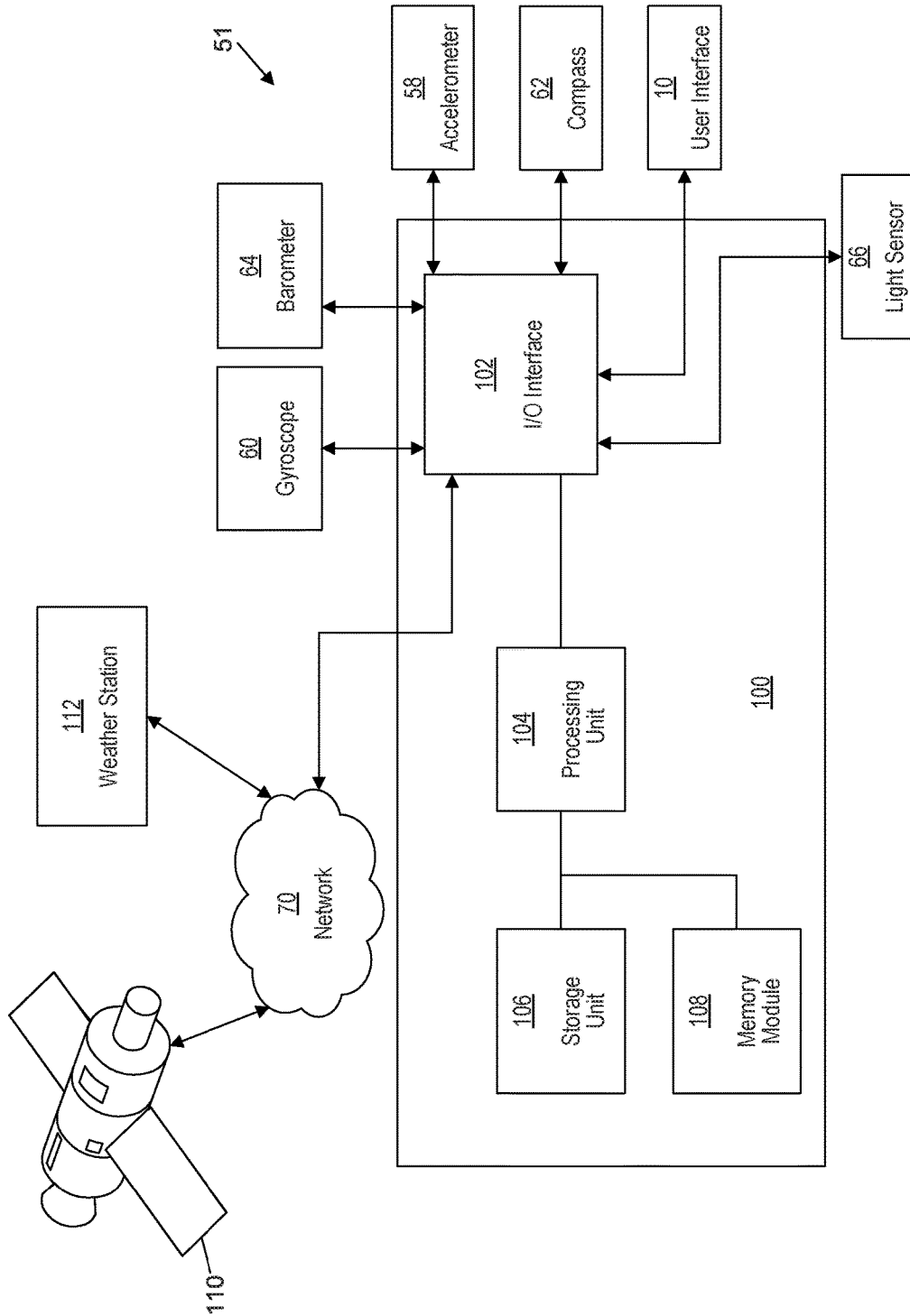

FIG. 3

1000

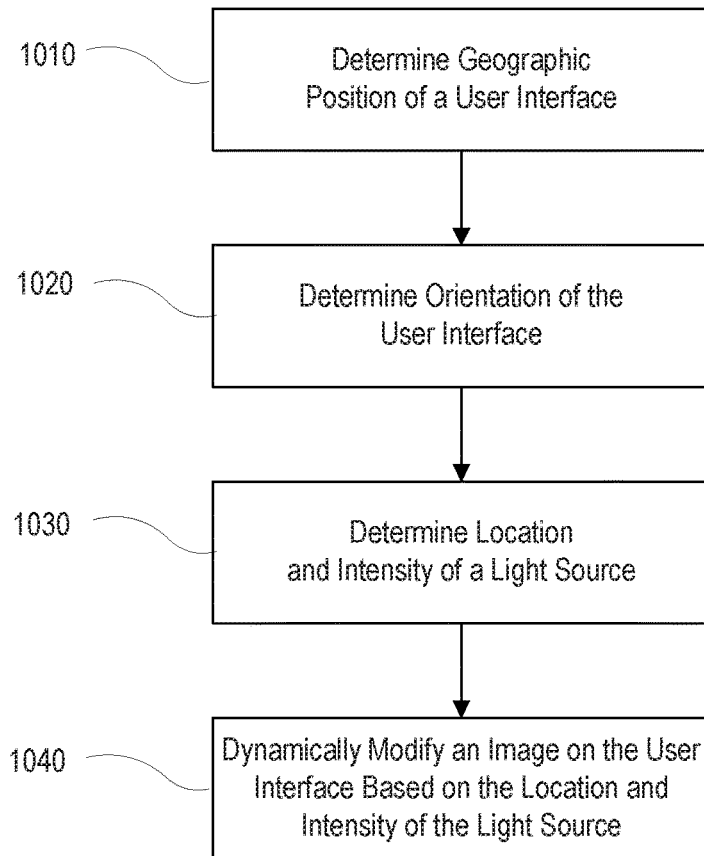

FIG. 4

METHODS AND SYSTEMS FOR GENERATING DYNAMIC USER INTERFACE EFFECTS

CROSS REFERENCE TO RELATED APPLICATIONS

[0001] This application claims the benefit of priority from U.S. Provisional Patent Application No. 62/248,485 filed on Oct. 30, 2015, the entire disclosures of which is incorporated by reference.

TECHNICAL FIELD

[0002] The present disclosure relates generally to methods and systems for generating user interface effects, and more particularly, to methods and systems for dynamically generating user interface effects based on real world lighting conditions.

BACKGROUND

[0003] User interfaces display information and provide images to facilitate input from the user to transmit data or initiate certain actions. Designers attempt to display the user interfaces in a manner that creates an intuitive interaction with the user. In some instances, designers have attempted to incorporate optical effects to provide structure, order, and visual hierarchy to the user. In some instances, user interface design has attempted to incorporate effects designed to simulate three-dimensional objects in two dimensions.

[0004] For example, drop shadows are generated on user interfaces by defining a fixed angle and fixed opacity to simulate a shadow. For instance, a designer might specify that a shadow is 20% opaque, at a 90° angle below a simulated button, and offset by 2 pixels on a y-axis. However, these values are hard-coded and exported as a static image asset to be included in the user interface. The static nature of the image asset prevents the interface element from reacting dynamically to changing light conditions and/or orientations.

[0005] The disclosed methods and systems may be directed to mitigating or overcoming one or more of the problems set forth above and/or other problems in the prior art.

SUMMARY

[0006] One aspect of the present disclosure is directed to a method for generating dynamic user interface effects. The method may include receiving positioning data indicative of a location of the user interface and receiving orientation data indicative of the orientation of the user interface. The method may also include determining a location of a light source relative to the user interface based on the positioning data and the orientation data, and dynamically modifying an image on the user interface based on the location of the light source.

[0007] Another aspect of the present disclosure is directed to a system for generating dynamic user interface effects. The system may include an interface configured to receive positioning data indicative of a location of the user interface and orientation data indicative of an orientation of the user interface. The system may also include a processing unit configured to determine a location of a light source relative to the user interface based on the positioning data and the

orientation data, and modify an image on the user interface based on the location of the light source.

[0008] Yet another aspect of the present disclosure is directed to a vehicle. The vehicle may include a user interface and a system. The system may include an interface configured to receive positioning data indicative of a location of the user interface and orientation data indicative of an orientation of the user interface. The control interface may also include a processing unit configured to determine a position of a light source relative to the user interface based on the positioning data and the orientation data, and modify an image on the user interface based on the relative position of the light source.

BRIEF DESCRIPTION OF THE DRAWINGS

[0009] FIG. 1 is a diagrammatic illustration of an exemplary user interface according to an exemplary embodiment.

[0010] FIG. 2 is a diagrammatic illustration of an exemplary embodiment of an interior of an exemplary vehicle that may house the exemplary user interface of FIG. 1 according to an exemplary embodiment.

[0011] FIG. 3 is a block diagram of an exemplary system that may be used with the exemplary vehicle of FIG. 2 according to an exemplary embodiment.

[0012] FIG. 4 is a flowchart illustrating an exemplary method that may be performed by the exemplary system of FIG. 3 according to an exemplary embodiment.

DETAILED DESCRIPTION

[0013] The disclosure is generally directed to methods and systems configured to dynamically adjust visual effects on a user interface based on changing real world conditions. In some embodiments, the disclosure is directed to estimating the geographic location and orientation of the user interface and determining the relative location and intensity of a light source (e.g., the sun or the moon). Used herein, intensity of a light source refers to the intensity of the light emitted, reflected, or otherwise provided by the light source. The disclosure may be applied to many different applications, such as a user interface in a moving vehicle.

[0014] FIG. 1 is a diagrammatic illustration of a user interface 10. User interface 10 may be configured to receive input from the user and transmit data. For example, user interface 10 may include a display such as an LCD, an LED, a plasma display, or any other type of display, and provide a Graphical User Interface (GUI) presented on the display for user input and data display. The display may include a number of different types of materials, such as plastic or glass, and may be touch-sensitive to receive commands from the user. For example, the display may include a touch-sensitive material that is substantially rigid, such as Gorilla Glass™, or substantially pliable, such as Willow Glass™. User interface 10 may be included in a vehicle, a smart phone, a tablet, and/or wearable technology, such as a smart watch or smart glasses.

[0015] As illustrated in FIG. 1, exemplary user interface 10 may include an array of pixels configured to depict a background 12 on which a number of features 14 are displayed. For example, in some embodiments, user interface 10 may include a number of icons 16 that may provide the user with shortcuts to a number of programs, such as a home icon, a phone icon, an email icon, and a network icon. When selecting the phone icon, for example, a window 18

may open that provides a keyboard **20** and a data field **22** which may, for example, allow operation of a cellular network. Icons **16** and keyboard **20** may be actuated by pressing the respective portion of the display. When selecting the network icon, user interface **10** may provide access to web browser. User interface **10** may also include a simulated knob **24**, which may be actuated by a rotational movement of the user. User interface **10** may further include a simulated slider switch **26**, which may be dragged along a groove **28** depicted on the display. User interface **10** may include other data fields to receive data, for example, from an incoming phone call. User interface **10** may define Cartesian coordinates, such as x-, y-, and z-coordinates.

[0016] As illustrated in FIG. 1, features **14** of user interface **10** may have a variety of different shapes and sizes in order to improve ease of differentiation and/or operation. Features **14** may have an image shape and size along the x/y coordinates that is depicted on the plane of user interface **10**. For example, simulated knob **24** may appear as a large round shape to encourage rotation by a finger of the user. On the other hand, icons **16** may be relatively smaller and square shaped because icons **16** relate to activating or de-activating a program rather than adjusting an adjustable feature such as volume. In order to enhance the simulation of three-dimensional characteristics of the icons, features **14** may also be configured to have an apparent height extending in the z-axis away from background **12**.

[0017] The apparent height of features **14** may be depicted with design features, such as modifying the contrast of images on and/or around feature **14**. For example, if feature **14** was designed with an arcuate surface extending in the z-plane, at least a portion of the periphery of feature **14** may be provided a gradient of shading to simulate an apparent light source hitting an elevated portion of the surface prior to the periphery. Depending on its shape, feature **14** may also cast a shadow **30** onto other components of user interface **10**, such as adjacent portion of background **12** and/or proximate features **14**. Shadow **30** may be determined by the relative size of features **14**. For example, features **14** that have a larger dimension (or that are elevated) in at least one of the x-, y-, and z-axes may produce a larger shadow **30**. Depending on the size of shadow **30**, larger features **14** may block the apparent light source from smaller features **14**. It is also contemplated that the size of features **14** may change in order to highlight aspects of user interface **10**. For example, when user interface **10** is receiving an incoming phone call, data fields **22** having data pertaining to the phone call may enlarge or be raised along the z-axis to become more prominent, casting a larger shadow **30** compared to other features **14**.

[0018] Shadow **30** extending from features **14** may also be simulated based on a location and/or intensity of an apparent light source. In some embodiments, the angle of shadow **30** may be calculated based on an angle of the apparent light source relative to the x-, y-, and z-axes of user interface **10**. For example, shadow **30** may be simulated according to tangential lines extending from the apparent light source to the edges of feature **14**, and extending the lines further to intersect with the x/y plane of background **12** and/or an adjacent feature **14**. The outline of shadow **30** may then be simulated by the accumulation of the intersecting points of background **12** and/or adjacent features **14**. Therefore, the number of pixels of shadow **30** may be geometrically calculated based on an angle of the apparent light source and

dimensions of features **14**. For example, smaller angles of the apparent light source (e.g., smaller z-axis coordinate) and larger sizes of feature **14** may increase the number of pixels in simulated shadow **30**.

[0019] The image of shadow **30** may also be simulated based on the intensity of the apparent light source, such that an increased intensity may create darker and more defined shadows **30**. For example, apparent light sources with a low intensity may generate shadows **30** having opacity of about 20%, while apparent light sources with a higher intensity may generate shadows **30** having opacity of about 80%. The relationship of the intensity of the apparent light source with the opacity of shadow **30** may be determined by, for example, a look-up table. Furthermore, each feature **14** may provide different shadows **30** depending on the location of the apparent light source. For example, if the apparent light source is located overhead user interface **10** between first and second features **14** along the x-axis, shadows **30** for first and second features **14** may extend in opposite directions along the x-axis. In some embodiments, the apparent light source may be designed to simulate real world lighting conditions.

[0020] FIG. 2 is an exemplary embodiment of an exemplary vehicle **50**. Vehicle **50** may have any body style, such as a sports car, a coupe, a sedan, a pick-up truck, a station wagon, a sports utility vehicle (SUV), a minivan, or a conversion van. Vehicle **50** may be an electric vehicle, a fuel cell vehicle, a hybrid vehicle, or a conventional internal combustion engine vehicle. Vehicle **50** may be configured to be operated by a driver occupying vehicle **50**, remotely controlled, and/or autonomous. Vehicle **50** may be subject to a light source (e.g., the sun or the moon) **80** emitting light at an elevation angle, α , relative to the horizon, and at an azimuth angle, β (not shown), relative to an azimuth direction (e.g., due north). As further illustrated in FIG. 2, vehicle **50** may have a dashboard **52** from which a steering wheel **54** may project, and user interface **10**. Vehicle **50** may also include a number of sensors, such as an accelerometer **58**, a gyroscope **60**, a barometer **64**, and a light sensor **66**.

[0021] Accelerometer **58** may be configured to determine static acceleration (e.g., gravity) and/or dynamic acceleration (e.g., sudden starts/stops) of user interface **10**. For example, if user interface **10** is stationary, accelerometer **58** may be configured to sense orientation data related to an orientation of user interface **10** by sensing gravity. In some embodiments, accelerometer **58** may include a sensor configured to measure the acceleration of a mass relative to a reference point. The sensor may include piezoelectric, piezoresistive, and/or capacitive elements configured to convert a mechanical force generated by the motion of the mass into an electric signal indicative of accelerations of user interface **10**.

[0022] Gyroscope **60** may be configured to determine an angular velocity of user interface **10** relative to the x-, y-, and z-axes. In some embodiments, gyroscope **60** may include an off-center mass that is shifted radially as the orientation and angular velocity of user interface **10** changes. The sensor may include piezoelectric, piezoresistive, and/or capacitive elements configured to convert a mechanical force from the motion of the mass into an electric signal indicative of the angular velocity of user interface **10**. In some embodiments, accelerometer **58** and gyroscope **60** may be positioned on the same circuit board. For example, accelerometer **58** and gyroscope **60** may be

positioned in circuitry of either user interface **10** and/or an onboard computer of vehicle **50**. The signal of accelerometer **58** and the signal of gyroscope **60** may be used in combination to improve the accuracy and detail of the orientation data. For example, circuitry may include a filter that receives both the signal of accelerometer **58** and the signal of gyroscope to generate a signal indicative of the orientation data.

[0023] Compass **62** may, additionally or alternatively, be used to determine the orientation of user interface **10** according to at least one axis. For example, compass **62** may include magnets that interact with the planetary magnetic field to detect the azimuth direction and determine orientation data indicative of the relative orientation of x-, y-, and z-axis of user interface **10**. Compass **62** may also be configured to generate a signal according to the orientation data.

[0024] Barometer **64** may be configured to measure the local air pressure of user interface **10**. In some embodiments, barometer **64** may include a piezoelectric, piezoresistive, and/or capacitive elements that expands (as the pressure falls) or contracts (as the pressure rises) and generates corresponding electric signals indicative of the local air pressure of user interface **10**. The altitude of user interface **10** may then be determined based on the air pressure measured by barometer **64** according to look-up tables and/or calculations. Barometer **64** may be positioned anywhere relative to user interface **10**. Barometer **64** may be positioned on an exterior surface of vehicle **50** (e.g., on a hood or roof) or interior of vehicle **50** (e.g., in housing of user interface **10**).

[0025] Light sensor **66** may include a number of different mechanisms configured to measure the light received from light source **80**. In some embodiments, light sensor **66** may include one or more of photocells, phototransistors, photovoltaic cells, light emitting diodes (LEDs), and/or active-pixel sensors (APSs). For example, light sensor **66** may include APSs consisting of an integrated circuit containing an array of pixel sensors. The light from light sensor **66** may generate a voltage across the APSs which may be measured to determine the intensity of light source **80**. The array of sensors may also be configured to detect an angle of light source **80** relative to the array of sensors. Light sensor **66** may also be configured to generate an electric signal indicative of the intensity and/or angle of light source **80** relative to user interface **10**. Light sensor **66** may be positioned on an exterior surface, such as, on a hood or roof of vehicle **50**. Light sensor **66** may advantageously be configured to determine instantaneous changes in light source **80**, such as when light source **80** moves from a relatively obstructed location (e.g., behind clouds) to a relatively unobstructed location, and vice versa. Furthermore, since the accuracy of light source **64** may be compromised because of other obstructions (e.g., dirt, dust, and/or paint), the signal generated by light sensor **66** may be adjusted (e.g., normalized) relative to recorded weather data.

[0026] FIG. 3 provides a block diagram of an exemplary system **51** that may be used in accordance with a method of controlling operation of user interface **10**. As illustrated in FIG. 3, system **51** may include a controller **100** having, among other things, an I/O interface **102**, a processing unit **104**, a storage unit **106**, and a memory module **108**. One or more of the components of controller **100** may be installed in user interface **10** and/or in an on-board computer of

vehicle **50**. These units may be configured to transfer data and send or receive instructions between or among each other.

[0027] I/O interface **102** may be configured for two-way communication between controller **100** and various components of system **51**, such as user interface **10**, accelerometer **58**, gyroscope **60**, compass **62**, barometer **64**, and/or light sensor **66**. I/O interface **102** may also be configured to send and receive operating signals to and from satellite **110** and weather station **112**. I/O interface **102** may send and receive the data between each of the devices via communication cables, wireless networks, or other communication mediums. For example, satellite **110** and weather station **112** may be configured to send and receive signals to I/O interface **102** via a network **70**. Network **70** may be any type of wired or wireless network that may allow transmitting and receiving data. For example, network **70** may include radio waves, a nationwide cellular network, a local wireless network (e.g., Bluetooth™ or WiFi), and/or a wired network. Processing unit **104** may be configured to receive signals and process the signals to determine real world lighting conditions. Processing unit **104** may also be configured to generate and transmit command signals, via I/O interface **102**, in order to actuate the devices in communication.

[0028] In some embodiments, processing unit **104** may be configured to determine a geographic position of user interface **10**. For example, processing unit **104** may be configured to lock onto a plurality of satellites **110** in order to triangulate the current latitude, longitude, and/or altitude, for example, with a global positioning system (GPS). Processing unit **104** may also be configured to compare the determined position to locations of natural and man-made structures that may affect the lighting of user interface **10** and/or vehicle **50**. For example, processing unit **104** may be configured to determine position of user interface **10** relative to elevated regions (e.g., mountains), tunnels, large buildings, and landscape (e.g., trees). In some embodiments, processing unit **104** may, additionally or alternatively, be configured to determine the altitude of user interface **10** based on a signal generated by barometer **64**. Barometer **64** may provide more accurate data regarding the altitude of user interface **10** according to local air pressure measurements.

[0029] Processing unit **104** may also be configured to determine orientation data pertaining to the orientation of the x-, y-, and z-axes of user interface **10**, for example, relative to the azimuth direction. In some embodiments, processing unit **104** may be configured to determine the orientation based on the GPS data. For example, when user interface **50** is moving at a rate of speed, processing unit **104** may be configured to analyze the current and previous positions of user interface **10** to determine current orientation data of user interface **10**. However, orientation data extracted from the GPS data may not be accurate, especially at low rates of speed; therefore processing unit **104** may be configured to determine the orientation data, additionally or alternatively, through signals generated by local sensors, such as accelerometer **58**, gyroscope **60**, and/or compass **62**. For example, processing unit **104** may be configured to use one or more of local sensors **58**, **60**, **62** to determine orientation of the x-, y-, and z-axes of user interface **10** based on the acceleration of gravity and/or the planetary magnetic field.

[0030] Processing unit **104** may be configured to query weather station **112** to determine local atmospheric condi-

tions. For example, processing unit **104** may be configured to acquire data from weather station **112** pertaining to the position of light source **80**, such as the elevation angle, α , and azimuth angle, β . Processing unit **104** may, additionally or alternatively, be configured to determine the location of light source **80** based on solar charts and/or lunar charts stored as look-up tables in storage unit **106** and/or memory module **108**. For example, processing unit **104** may be configured to calculate the exact position of light source **80** according to the specific date, time, and/or geographic position based on the solar charts and/or lunar charts. Processor **104** may be further configured to query weather station **112** to determine other local atmospheric conditions, such as the local solar intensity and conditions that may reduce the solar intensity, such as cloud coverage and/or air quality (e.g., pollution). In certain circumstances, processing unit **104** may be configured to determine the local atmospheric conditions based on other mechanisms, such as local sensors. For example, when it is determined that the weather conditions are “partly cloudy” such that the received intensity of light source **80** may change instantaneously, processing unit **104** may be configured to determine the instantaneous light intensity based on signals generated by light sensor **66**.

[0031] Processing unit **104** may be configured to dynamically modify an image on user interface **10** based on the location of light source **80**. In some embodiments, processing unit **104** may be configured to project elevation angle, α , and azimuth angle, β , of light source **80** onto x-, y-, and z-axes of user interface **10**. For example, processing unit **104** may be configured to geometrically convert the elevation angle, α , and azimuth angle, β , of light source **80** to determine a location of an apparent light source according to the x-, y-, and z-axes of user interface **10**. Processing unit **104** may be configured to generate an outline of shadow **30** projecting from at least one feature **14** according to the apparent light source. For example, processing unit **104** may be configured to simulate lines extending from the apparent light source to the edges of features **14**, and extending the simulated lines further to intersect with the x/y plane of background **12** and/or an adjacent feature **14**.

[0032] Processing unit **104** may also be configured to determine the opacity of shadow **30** based on an apparent intensity of light source **80**. For example, processing unit **104** may be configured to determine an intensity of light source **80** based on at least one of acquired data from weather station **112**, signals generated by light sensor **64**, and/or a calculated distance of light source **80** based on, for example, the time of year, latitude, longitude, and/or altitude. Based on the determined intensity of light source **80**, processing unit **104** may be configured to correlate the opacity of shadow **30** according to look-up tables stored in storage unit **106** and/or memory module **108**. Processing unit **104** may then be configured to provide shading of shadow **30** based on the determined opacity.

[0033] At times when light source **80** is physically located behind user interface **10**, system **51** may perform a number of different functions. In some embodiments, processing unit **104** may be configured to overlay shadow **30** on top of feature **14** to provide a realistic effect of light source **80**. However, in some embodiments, processing unit **104** may be configured to project shadow **30** behind features **14** onto background **12** even when light source **80** is behind background **12**, in order to ensure visibility of features **14**.

[0034] Storage unit **106** and/or memory module **108** may be configured to store one or more computer programs that may be executed by controller **100** to perform functions of system **11**. For example, storage unit **106** and/or memory module **108** may be configured to store GPS software configured to determine geographic positioning based on communication with satellites **110**. Storage unit **106** and/or memory module **108** may also be configured to store data and/or look-up tables used by the processing unit. For example, storage unit **106** and/or memory module **108** may be configured to store data pertaining to the size and location of features **14** on user interface **10**. Storage unit **106** and/or memory module **108** may also be configured to store look-up tables correlating the intensity of light source **80** to opacity of shadow **30**.

[0035] FIG. **4** is a flowchart illustrating an exemplary process **1000** that may be performed by exemplary system **51** of FIG. **3**.

[0036] In Step **1010**, one or components of system **51** may determine the geographic position of user interface **10**. For example, processing unit **104** may execute GPS software to determine global positioning data of user interface **10**, for example, user interface **10** may be currently located at 35.8334° N, 120.2824° W at 4:50 PM PST on Oct. 31, 2015. Based on the GPS data, processing unit **104** may also determine that user interface **10** is in an urban area proximate to large buildings. In some embodiments, processing unit **104** may determine locations and heights of specific buildings that may block light source **80** relative to user interface **10**. In another example, processing unit **104** may be configured to determine when user interface **10** is positioned in a wooded area where light source **80** may be blocked, or in an open area where light source **80** may be more direct. Processing unit **104** may also be configured to determine that user interface **10** is positioned, for example, **233** feet above sea level according to either GPS data and/or barometer **64**.

[0037] In Step **1020**, one or more components of system **51** may determine the orientation of user interface **10**. In some embodiments, processing unit **104** may execute GPS software to determine orientation data of user interface **10**. For example, user interface **10** may be traveling east, such that the z-axis of user interface is currently directed west at an angle of 30° relative to the horizon. Processing unit **104** may, additionally or alternatively, determine the orientation data based on signals generated by at least one of accelerometer **58**, gyroscope **60**, and compass **62**.

[0038] In Step **1030**, one or more components of system **51** may determine the location and intensity of light source **80**. Processing unit **104** may also determine other local atmospheric conditions. For example, processing unit **104** may query weather station **112** to determine elevation angle, α , of light source **80** is about 40° relative to the horizon, and the azimuth angle, β , is about 31 30° relative to the azimuth direction. Processing unit **104** may also determine that it is full sun with a solar intensity of 1370 W/m². Processing unit **104** may also determine that it is an urban area, such that buildings may create obstructions of light source **80** at pre-determined locations of user interface **10**.

[0039] In Step **1040**, one or more components of system **51** may dynamically modify an image on user interface **10** based on the location and intensity of light source **80**. In some embodiments, processing unit **104** may be configured to simulate an apparent light source onto user interface **10**.

For example, processing unit **104** may determine the location and intensity of the apparent light source according to the x-, y-, and z-axes of user interface **10**. Processing unit **104** may geometrically convert the elevation angle, α , and azimuth angle, β , of light source **80** to determine a location of an apparent light source according to the x-, y-, and z-axes of user interface **10**. Processing unit **104** may simulate lines from the direction of the light source **80** to the edges of features **14**, and determine the points that the simulated lines intersect the x/y plane of background **12** and/or another feature **14**. Processing unit **104** may then connect the intersecting points to create an outline of shadow **30**. Processing unit **104** may also retrieve an opacity of shadow **30** from a look-up table according to the determined apparent intensity of 1370 W/m^2 . Processing unit **104** may reduce the opacity of shadow **30** based on when light source **80** is relatively obstructed, for example, when a building is positioned between user interface **10** and light source **80**.

[0040] Another aspect of the disclosure is directed to a non-transitory computer-readable medium storing instructions which, when executed, cause one or more processors to perform methods of the disclosure. The computer-readable medium may include volatile or non-volatile, magnetic, semiconductor, tape, optical, removable, non-removable, or other types of computer-readable medium or computer-readable storage devices. For example, the computer-readable medium may be the storage unit or the memory module having the computer instructions stored thereon, as disclosed. In some embodiments, the computer-readable medium may be a disc or a flash drive having the computer instructions stored thereon.

[0041] It will be apparent to those skilled in the art that various modifications and variations can be made to the disclosed system and related methods. Other embodiments will be apparent to those skilled in the art from consideration of the specification and practice of the disclosed system and related methods. It is intended that the specification and examples be considered as exemplary only, with a true scope being indicated by the following claims and their equivalents.

What is claimed is:

1. A method for generating dynamic user interface effects, the method comprising:

receiving positioning data indicative of a location of the user interface;

receiving orientation data indicative of an orientation of the user interface;

determining a location of a light source relative to the user interface based on the positioning data and the orientation data; and

dynamically modifying an image on the user interface based on the location of the light source.

2. The method of claim **1**, wherein dynamically modifying the image comprises simulating a shadow on the user interface based on the location of the light source.

3. The method of claim **2**, wherein the simulated shadow extends from a feature depicted on the user interface.

4. The method of claim **3**, wherein dynamically modifying the image comprises simulating the shadow based on a predetermined apparent dimension of the feature.

5. The method of claim **4**, wherein dynamically modifying the image comprises simulating the shadow based on a predetermined apparent height of the feature.

6. The method of claim **1**, further comprising receiving data related to an intensity of the light source and modifying an opacity of the image based on the intensity of the light source.

7. The method of claim **6**, further comprising modifying the opacity of the image based on at least one estimated obstruction of the light source.

8. The method of claim **1**, further comprising generating the orientation data using at least one of a gyroscope, an accelerometer, or a barometer.

9. The method of claim **1**, further comprising determining the location of the light source relative to the user interface with a light sensor.

10. The method of claim **1**, wherein modifying the image includes determining a plurality of pixels to be modified based on the location of the light source.

11. A system for generating dynamic user interface effects, the system comprising:

an interface configured to:

receive positioning data indicative of a location of the user interface; and

receive orientation data indicative of an orientation of the user interface;

a processing unit configured to:

determine a location of a light source relative to the user interface based on the positioning data and the orientation data; and

dynamically modify an image on the user interface based on the location of the light source.

12. The system of claim **11**, wherein the processing unit is configured to simulate a shadow on the user interface based on the location of the light source.

13. The system of claim **12**, wherein the simulated shadow extends from a feature depicted on the user interface.

14. The system of claim **13**, wherein the processing unit is configured to simulate the shadow based on a predetermined apparent dimension of the feature.

15. The system of claim **11**, wherein the processing unit is configured to receive data pertaining to an intensity of the light source and modify an opacity of the image based on the intensity of the light source.

16. The system of claim **15**, wherein the processing unit is configured to modify the opacity based on at least one estimated obstruction of the light source.

17. The system of claim **11**, further comprising at least one of a gyroscope, an accelerometer, or a barometer configured to generate the orientation data.

18. The system of claim **11**, wherein the processing unit is configured to determine the location of the light source relative to the user interface with a light sensor.

19. The system of claim **11**, wherein the processing unit is configured to determine a plurality of pixels to be modified based on the location of the light source.

20. A vehicle comprising:

a user interface;

a system comprising:

an interface configured to:

receive positioning data indicative of a location of the user interface; and

receive orientation data indicative of an orientation of the user interface;

a processing unit configured to:

determine a location of a light source relative to the user interface based on the positioning data and the orientation data; and

dynamically modify an image on the user interface based on the location of the light source.

* * * * *