



US008460212B2

(12) **United States Patent**  
**Nakamura et al.**

(10) **Patent No.:** **US 8,460,212 B2**  
(45) **Date of Patent:** **\*Jun. 11, 2013**

(54) **BODY FLUID SAMPLING UNIT**

(75) Inventors: **Toshihisa Nakamura**,  
Ashigarakami-gun (JP); **Daisuke**  
**Nishiuchi**, Ashigarakami-gun (JP)

(73) Assignee: **Terumo Kabushiki Kaisha**, Sibuya-Ku,  
Tokyo (JP)

(\* ) Notice: Subject to any disclaimer, the term of this  
patent is extended or adjusted under 35  
U.S.C. 154(b) by 0 days.

This patent is subject to a terminal dis-  
claimer.

(21) Appl. No.: **12/909,275**

(22) Filed: **Oct. 21, 2010**

(65) **Prior Publication Data**

US 2011/0034830 A1 Feb. 10, 2011

**Related U.S. Application Data**

(62) Division of application No. 11/905,053, filed on Sep.  
27, 2007, now Pat. No. 7,867,175.

(30) **Foreign Application Priority Data**

Sep. 27, 2006 (JP) ..... 2006-263547

(51) **Int. Cl.**  
**A61B 5/00** (2006.01)  
**A61F 2/02** (2006.01)  
**B65D 81/00** (2006.01)

(52) **U.S. Cl.**  
USPC ..... **600/584**; 600/583; 606/181; 606/182

(58) **Field of Classification Search**  
USPC ..... 600/583, 584; 606/4, 5, 181, 182,  
606/185

See application file for complete search history.

(56) **References Cited**

U.S. PATENT DOCUMENTS

4,627,445	A	12/1986	Garcia et al.	
4,637,403	A	1/1987	Garcia et al.	
5,100,620	A *	3/1992	Brenneman	422/417
5,114,862	A *	5/1992	Brenneman	436/169
5,196,025	A *	3/1993	Ranalletta et al.	606/182
5,279,294	A	1/1994	Anderson et al.	
5,736,103	A *	4/1998	Pugh	422/68.1
5,753,429	A *	5/1998	Pugh	435/4

(Continued)

FOREIGN PATENT DOCUMENTS

JP	61-286738	A	12/1986
JP	6-339473	A	12/1994

(Continued)

*Primary Examiner* — Sean Dougherty

(74) *Attorney, Agent, or Firm* — Buchanan Ingersoll &  
Rooney PC

(57) **ABSTRACT**

A body fluid sampling unit includes a puncture device including a needle having a sharp needle point and a drive mechanism for operating the needle to puncture a living body surface with the needle point, a tip including an introducing section for introducing a body fluid flowing out from a puncture portion of the living body surface punctured with the needle point, a test paper for detecting a predetermined component in the body fluid, and a tip body mounted to a component measuring device for measuring the quantity and/or property of the predetermined component detected by the test paper; and a case including a mechanism containing section for containing the puncture mechanism so that the needle point of the puncture mechanism can be moved by the drive means, and a sampling implement containing section for containing the body fluid sampling implement so that the tip can be taken out.

**20 Claims, 22 Drawing Sheets**

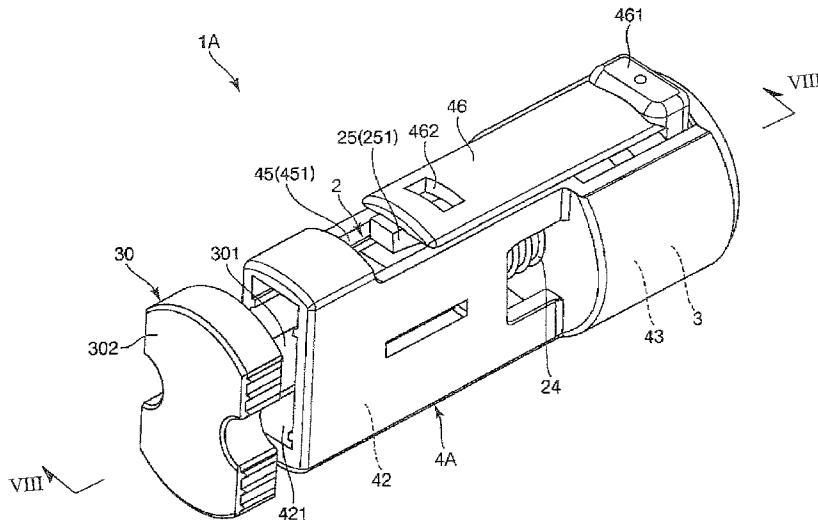

# US 8,460,212 B2

Page 2

## U.S. PATENT DOCUMENTS

5,872,713 A \* 2/1999 Douglas et al. .... 702/85  
6,083,460 A \* 7/2000 Morikawa et al. .... 422/404  
6,338,720 B1 1/2002 Morikawa et al.  
6,379,317 B1 \* 4/2002 Kintzig et al. .... 600/573  
6,840,912 B2 \* 1/2005 Kloepfer et al. .... 600/583  
7,264,627 B2 9/2007 Perez  
7,378,007 B2 5/2008 Moerman et al.  
7,586,610 B2 \* 9/2009 Nagasawa ..... 356/402  
7,695,676 B2 \* 4/2010 Kloepfer et al. .... 422/547  
7,901,364 B2 \* 3/2011 Kloepfer et al. .... 600/583  
2002/0188223 A1 12/2002 Perez et al.  
2003/0050573 A1 3/2003 Kuhr et al.  
2003/0144608 A1 7/2003 Kojima et al.  
2005/0277849 A1 12/2005 Wong et al.  
2006/0047220 A1 3/2006 Sakata et al.

2006/0222567 A1 \* 10/2006 Kloepfer et al. .... 422/68.1  
2008/0119760 A1 \* 5/2008 Lok et al. .... 600/583  
2009/0036915 A1 2/2009 Karbowniczek et al.  
2009/0118752 A1 5/2009 Perez et al.  
2009/0124931 A1 5/2009 Sakata et al.

## FOREIGN PATENT DOCUMENTS

JP 2003-502088 A 1/2003  
JP 2003-527920 A 9/2003  
JP 2005-122551 A 5/2005  
JP 2005-185852 A 7/2005  
WO WO 00/78203 A2 12/2000  
WO WO 01/72225 A1 10/2001  
WO WO 02/056769 A1 7/2002

\* cited by examiner

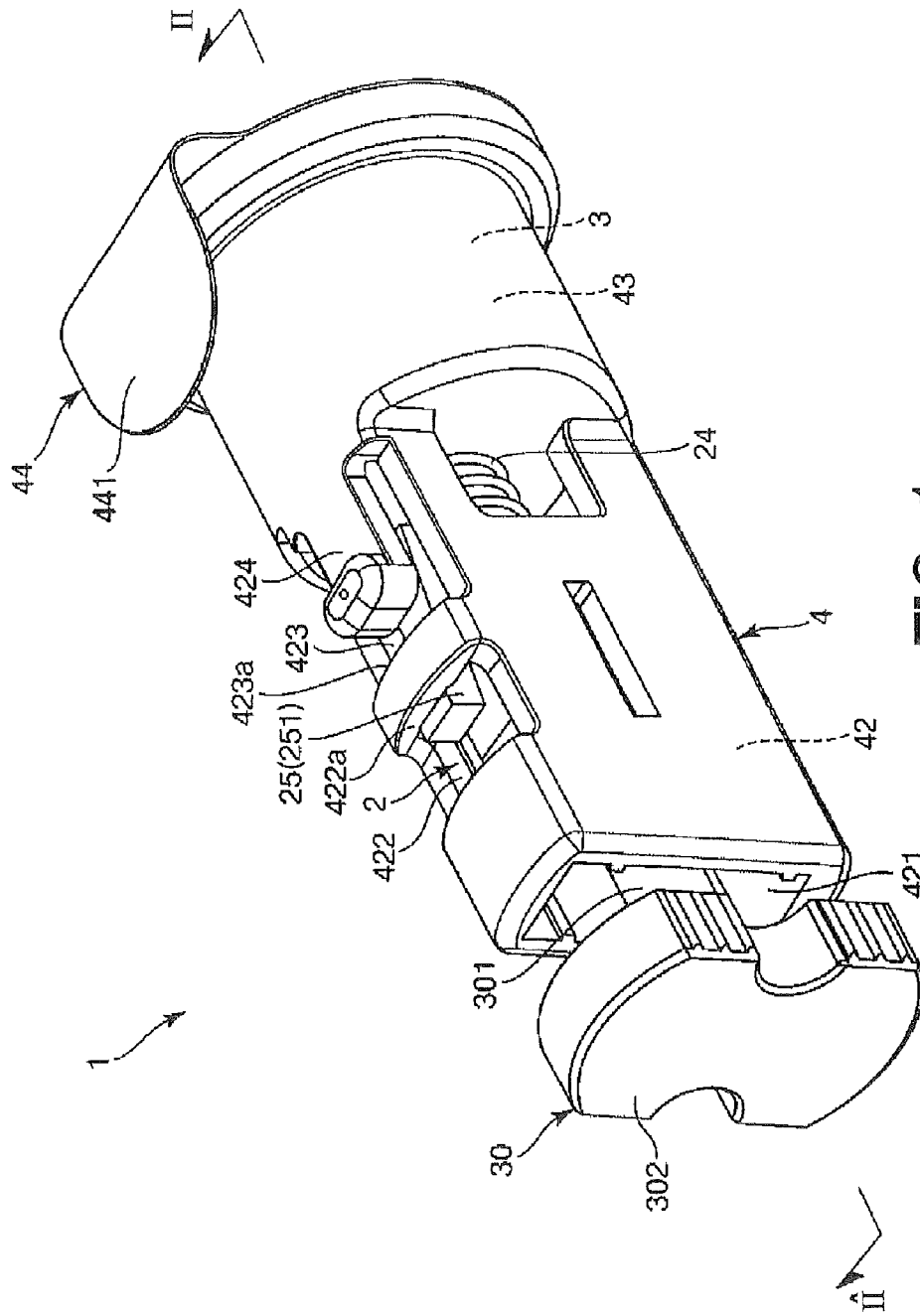

FIG. 1

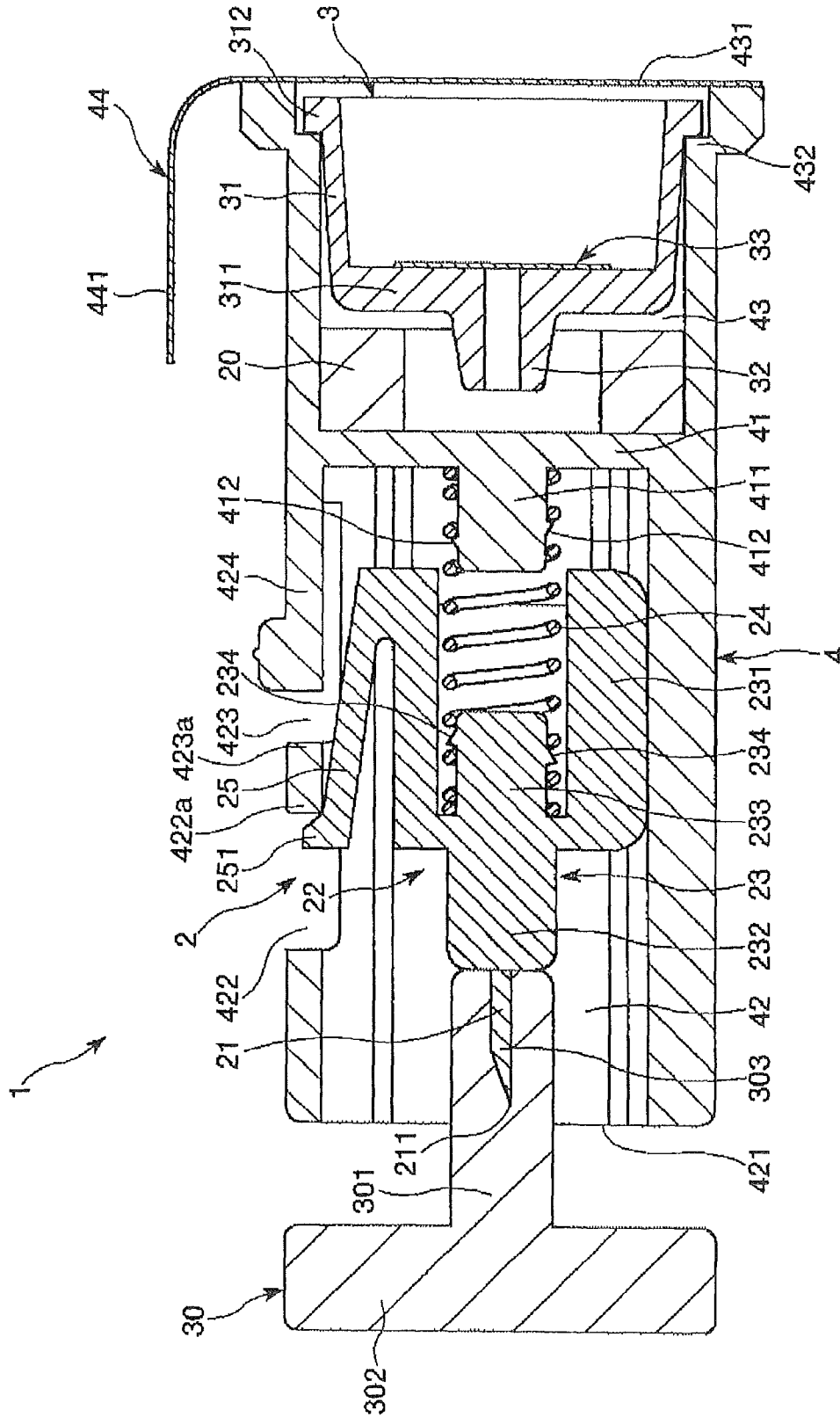

FIG. 2

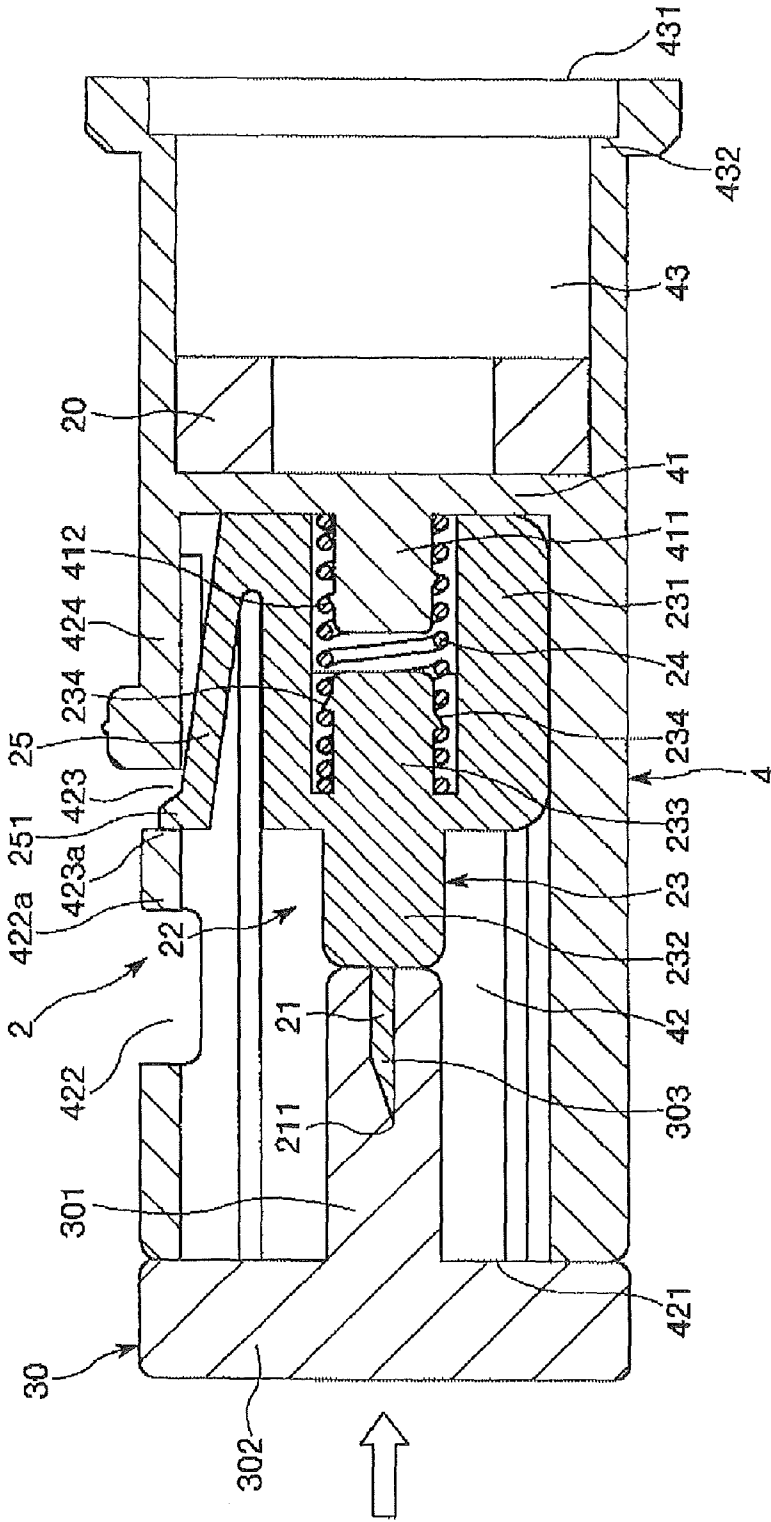

FIG. 3

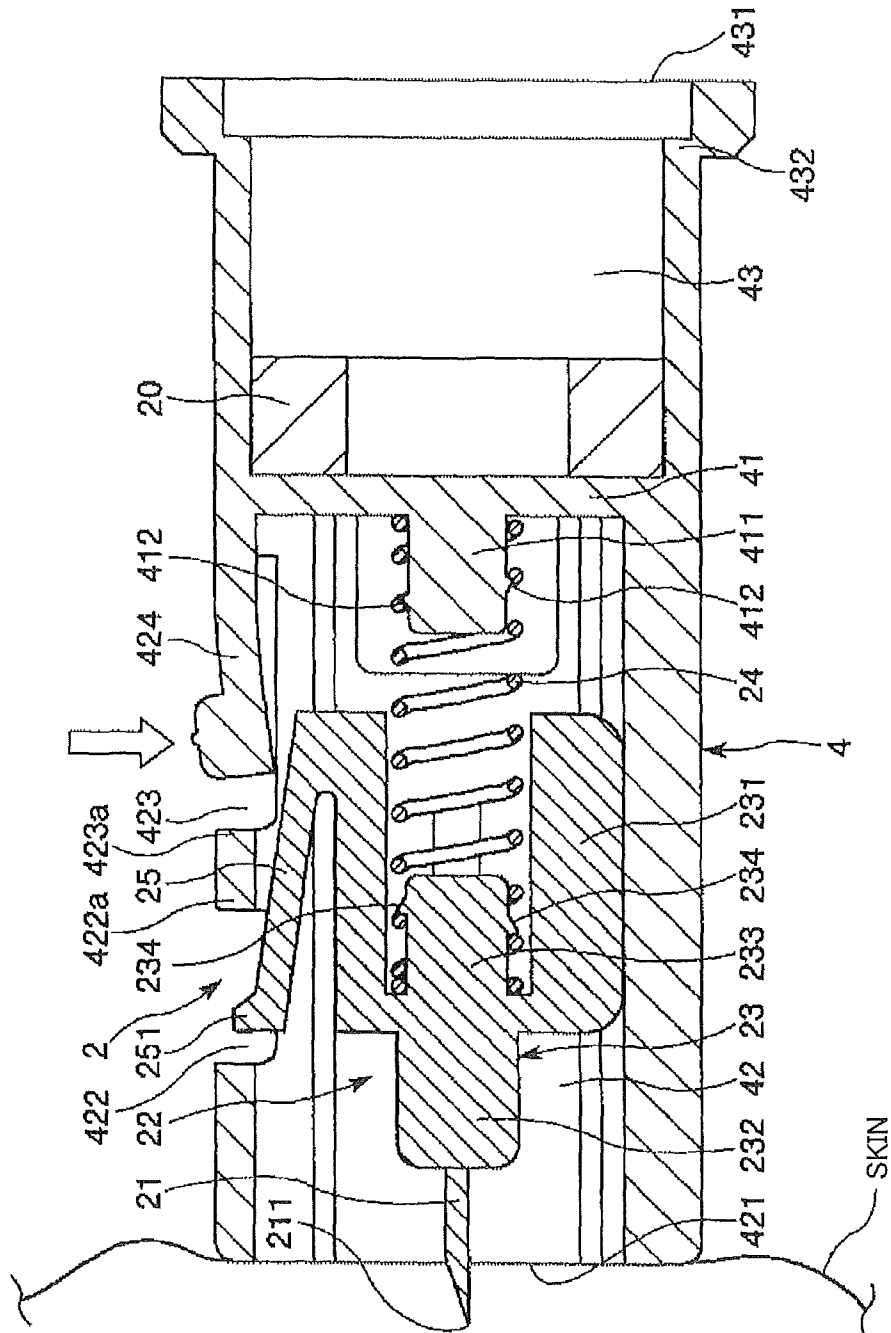
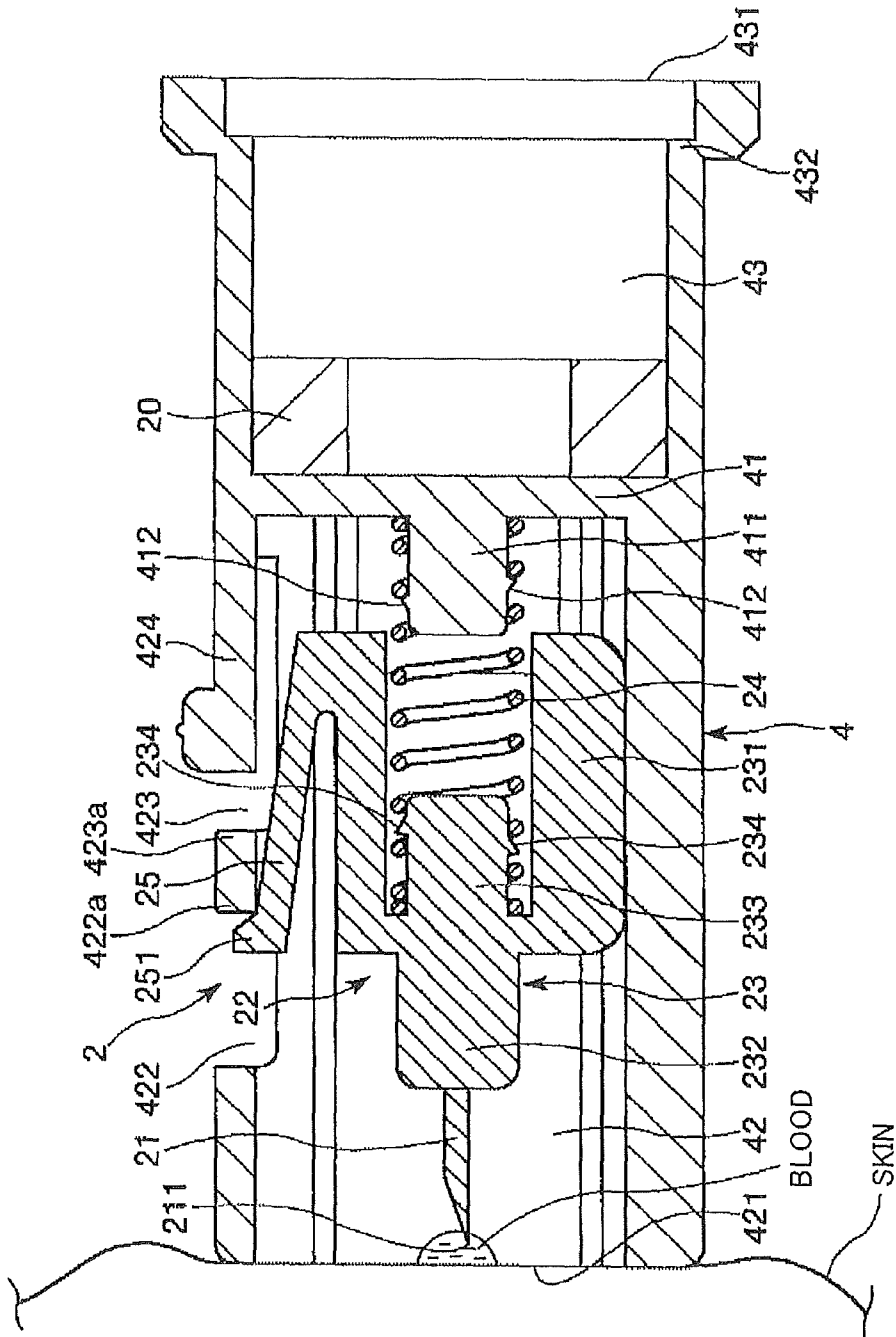

FIG. 4



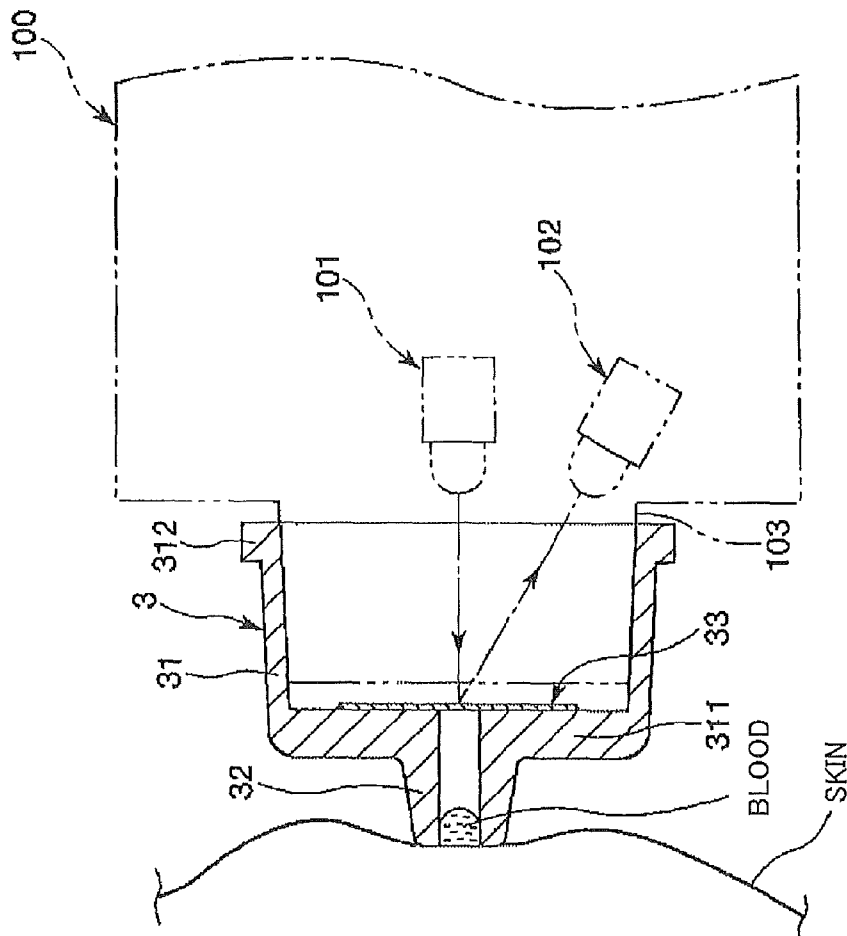

FIG. 6



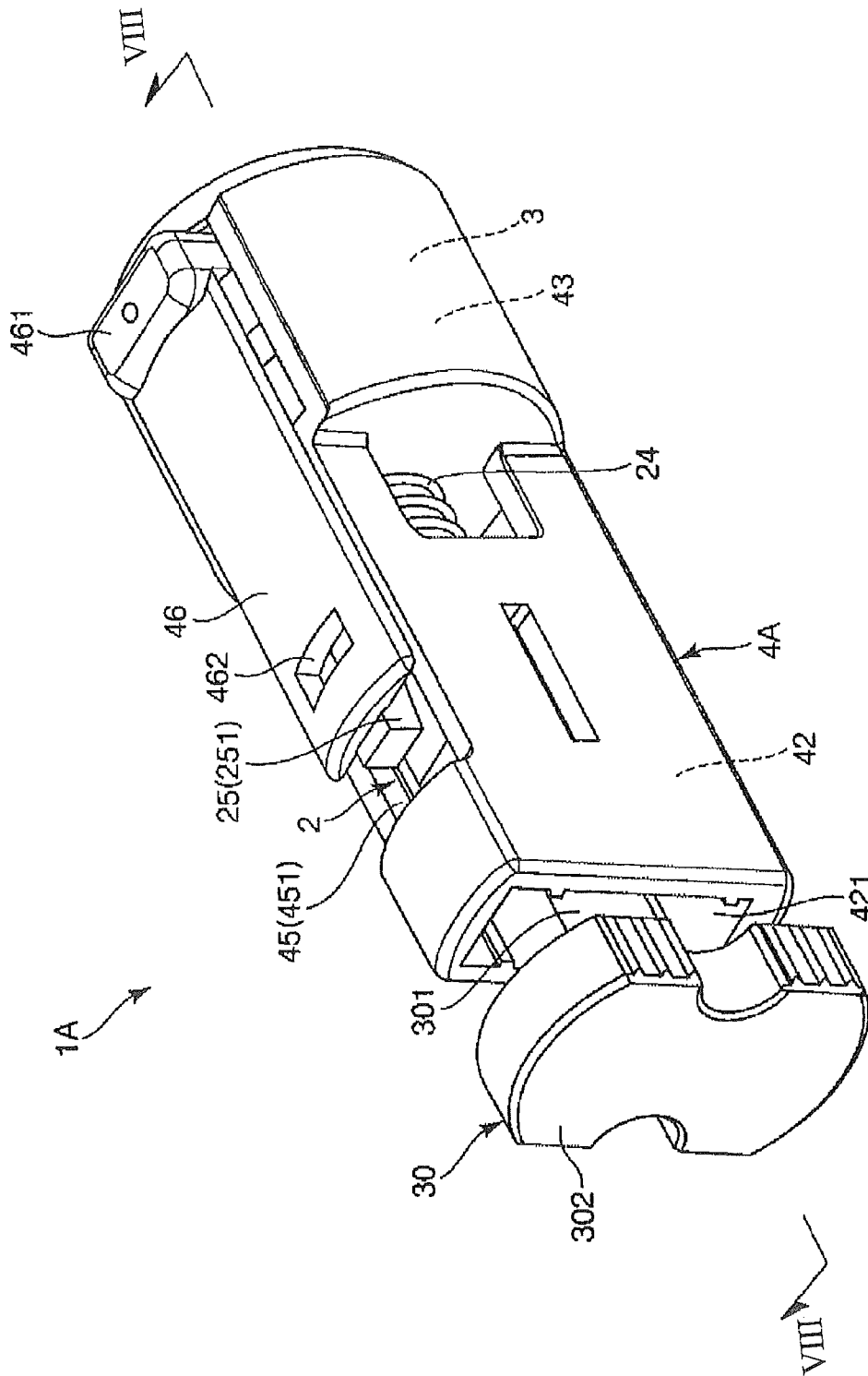

FIG. 7

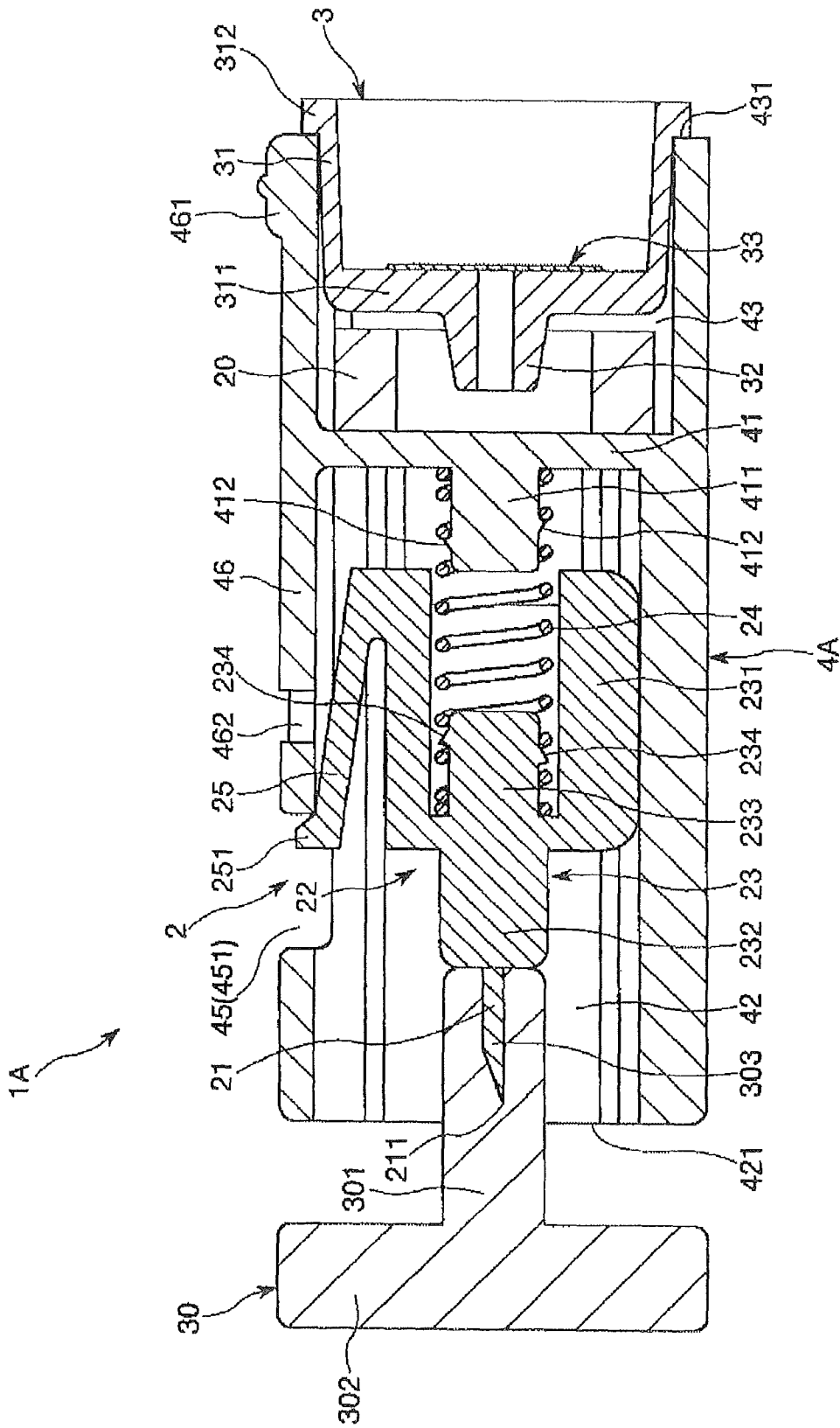

FIG. 8

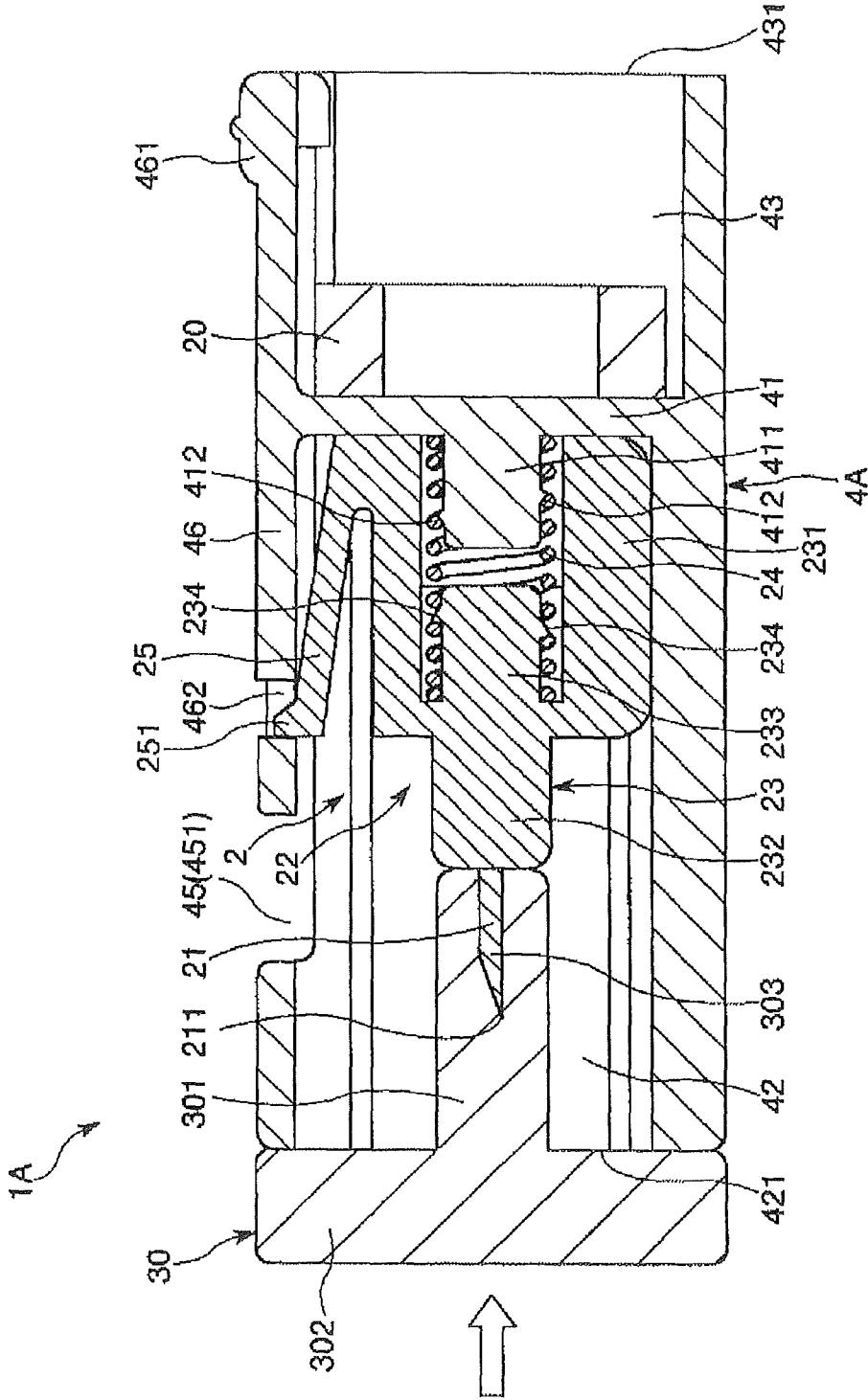

FIG. 9

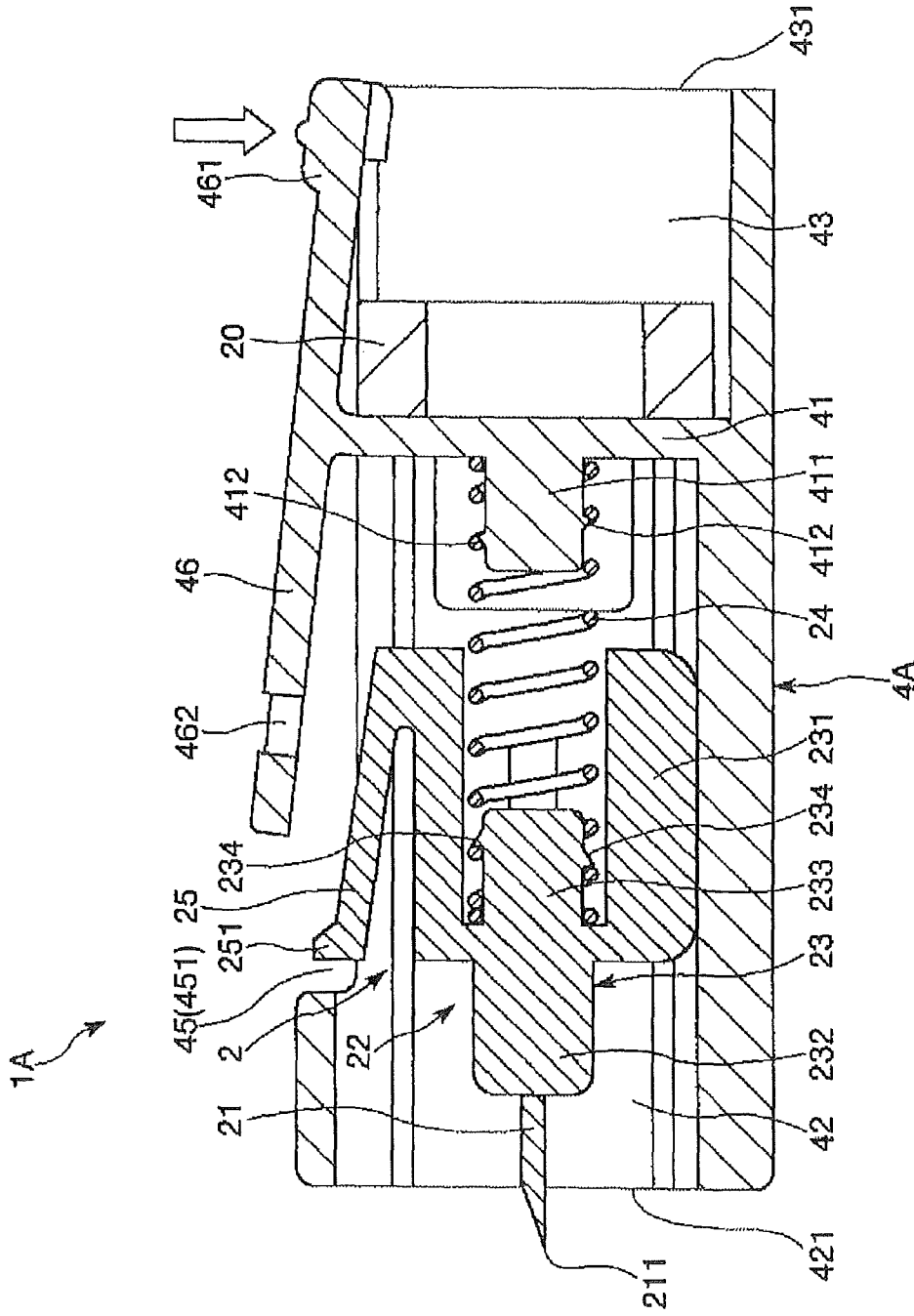

FIG. 10

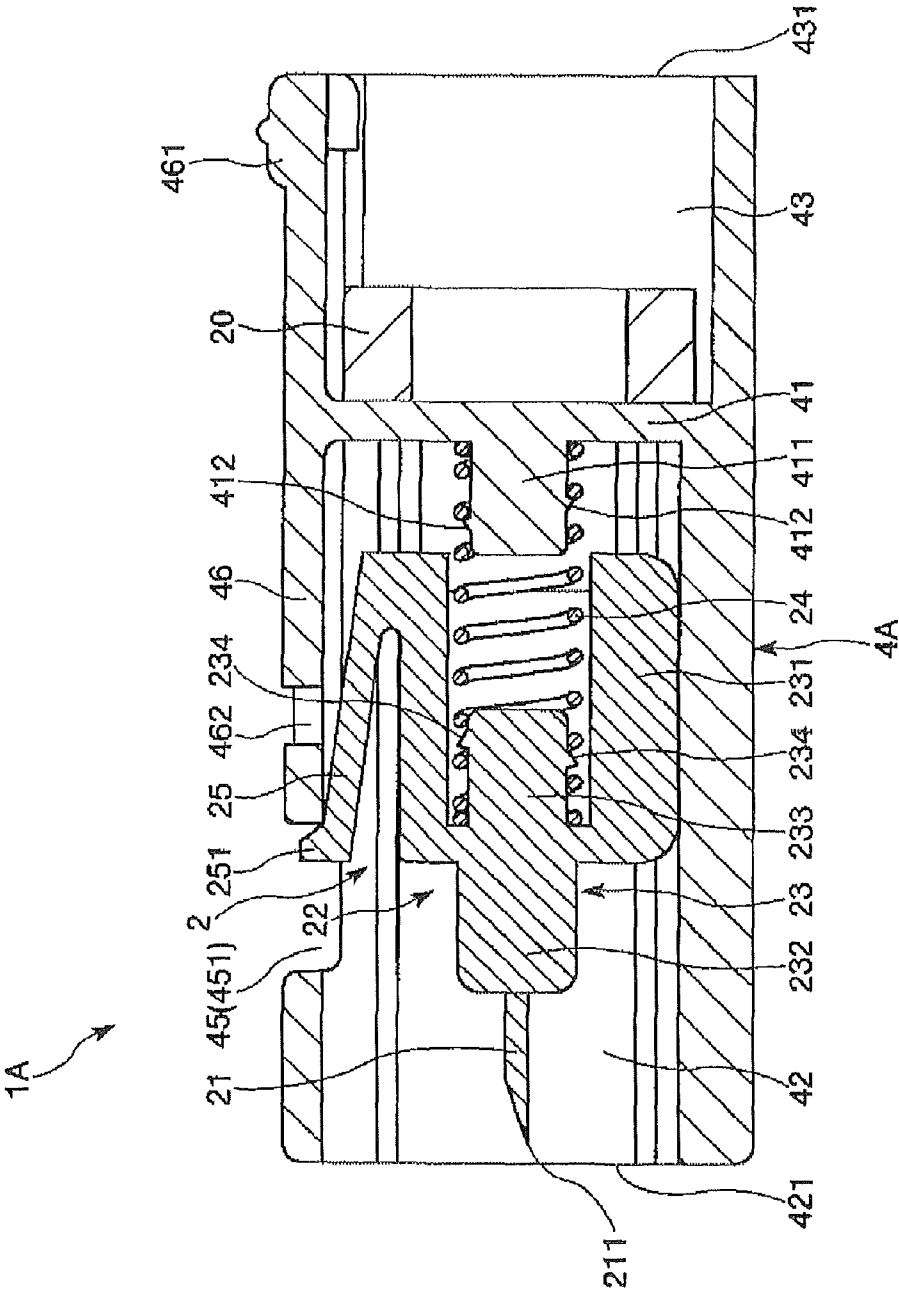

FIG. 11

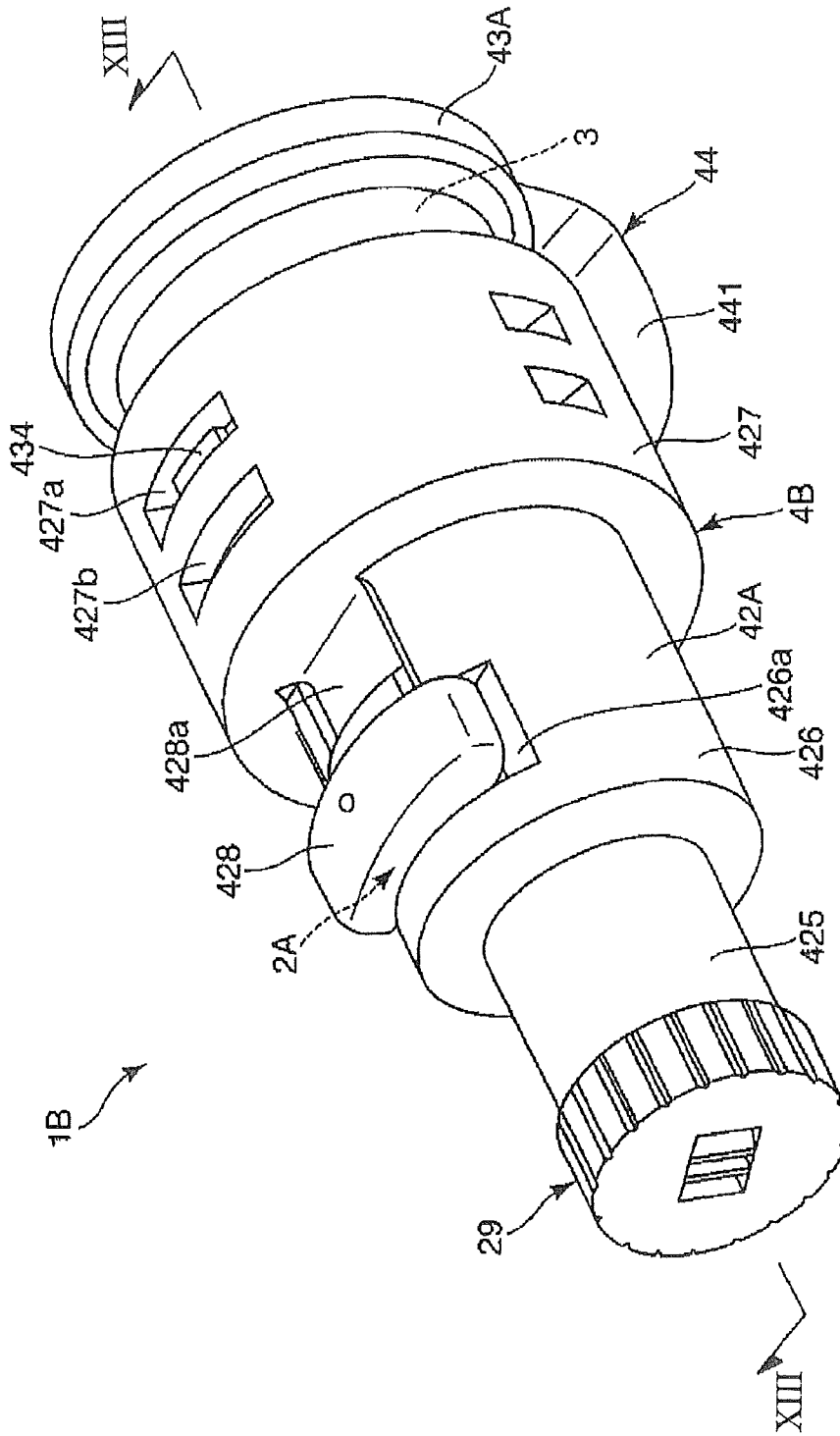

FIG. 12

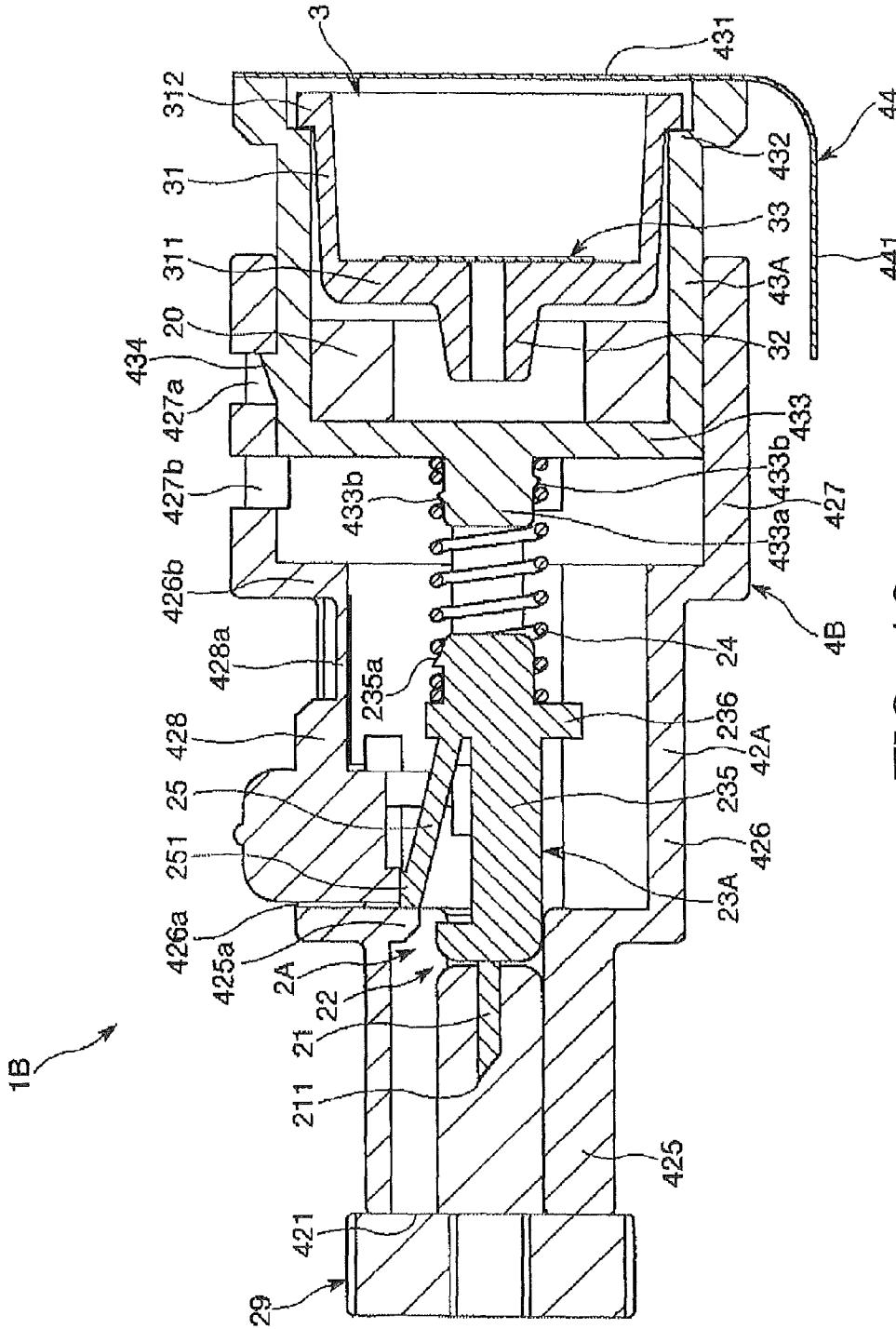

FIG. 13

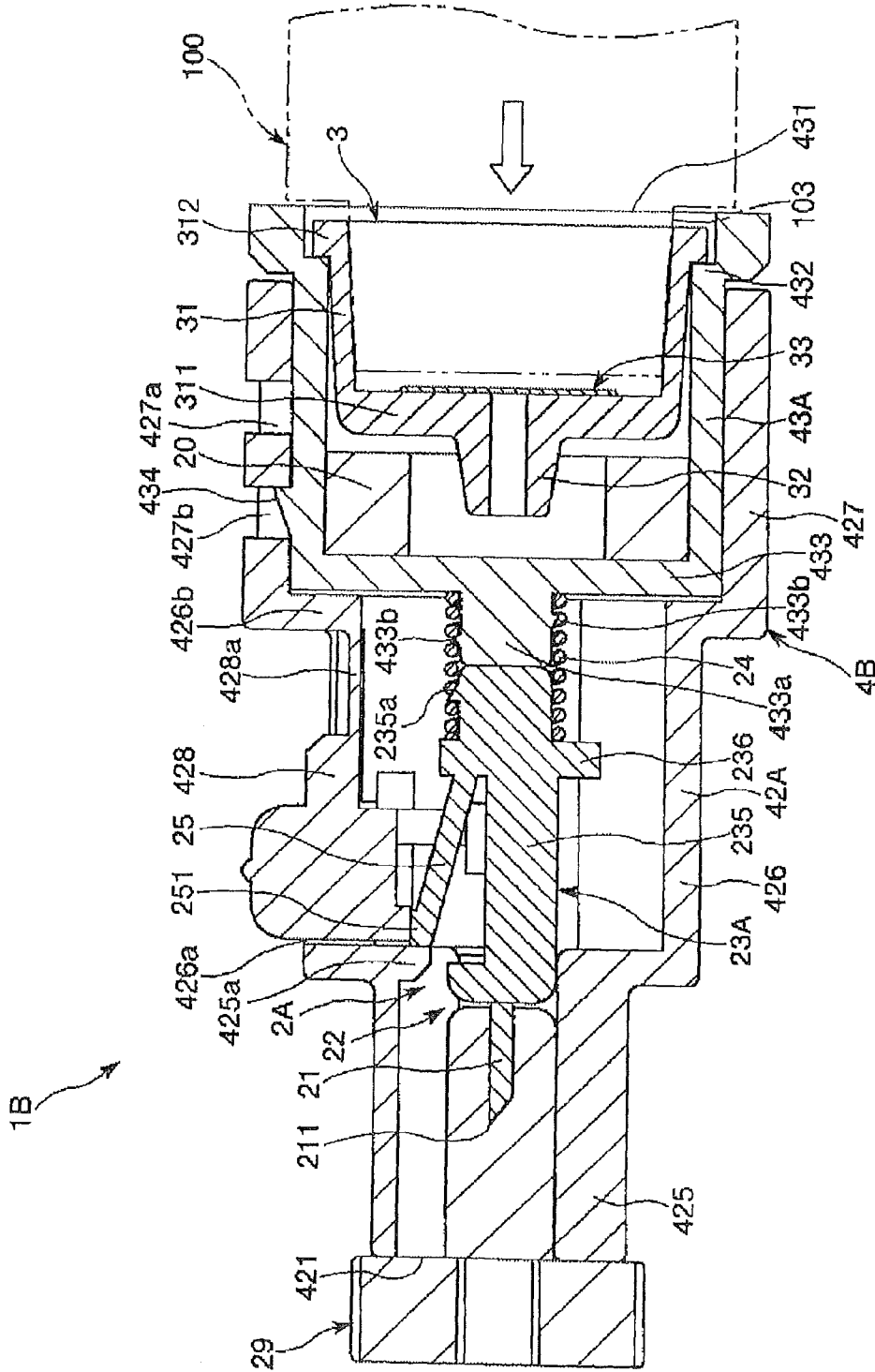

FIG. 14



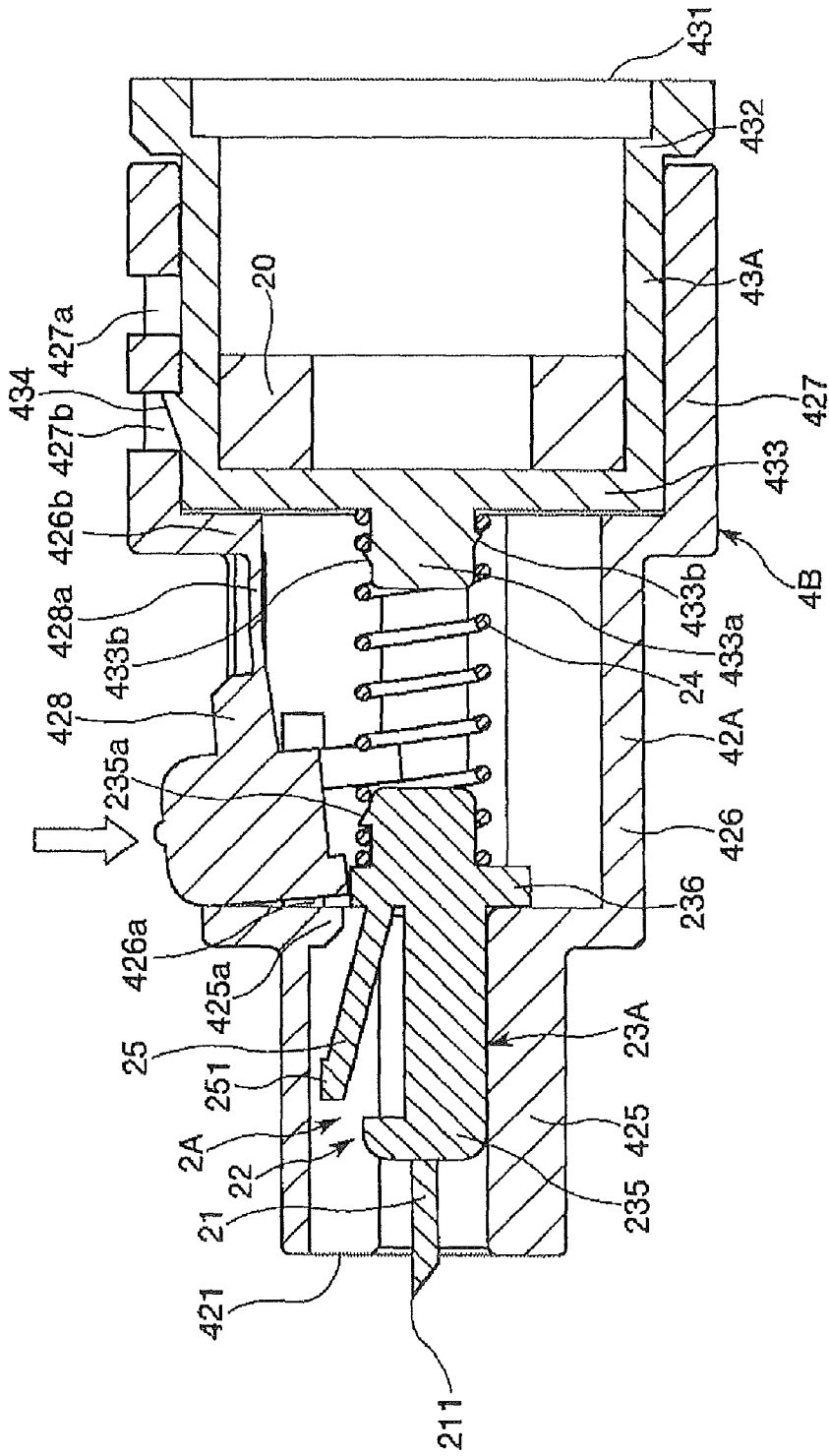

FIG. 15

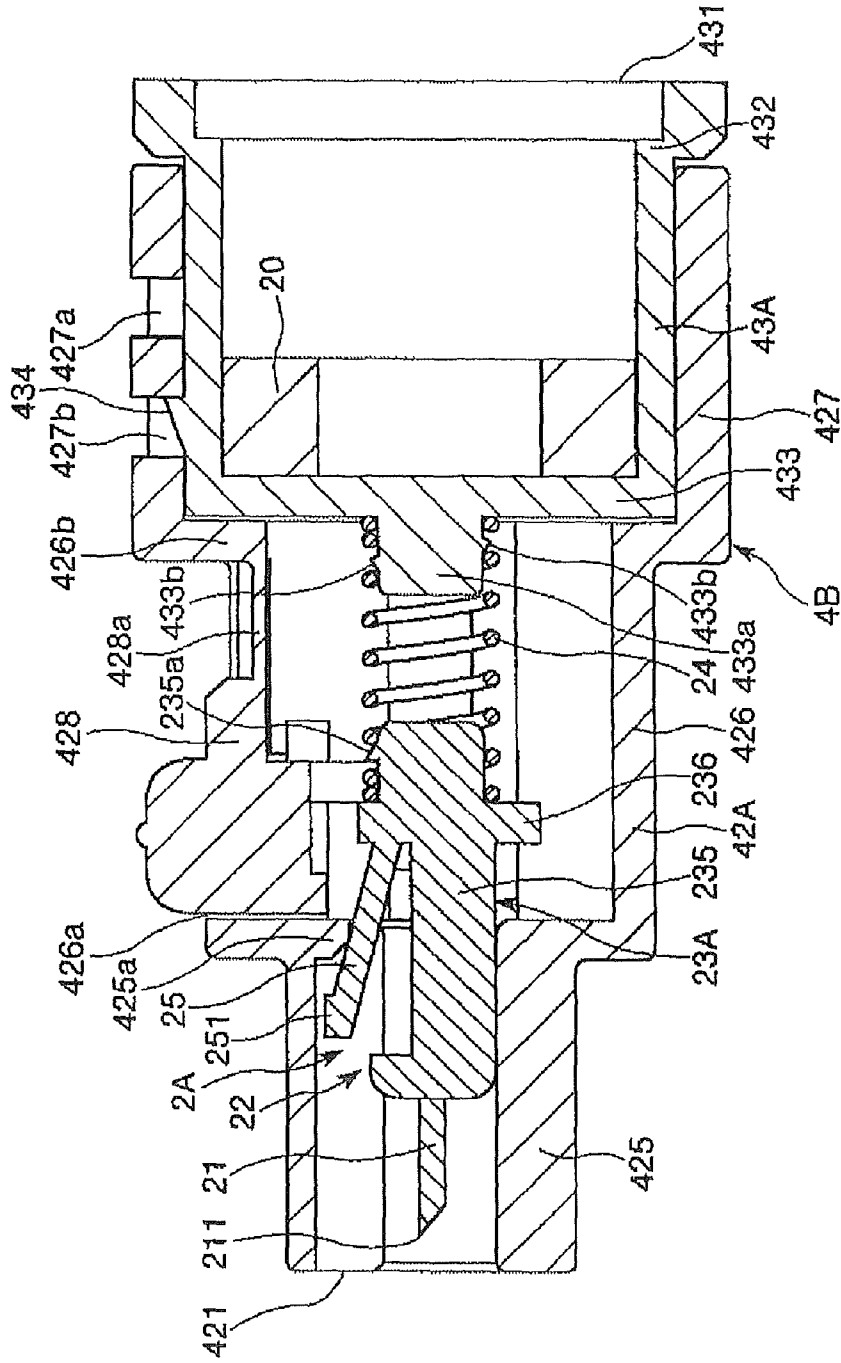

FIG. 16

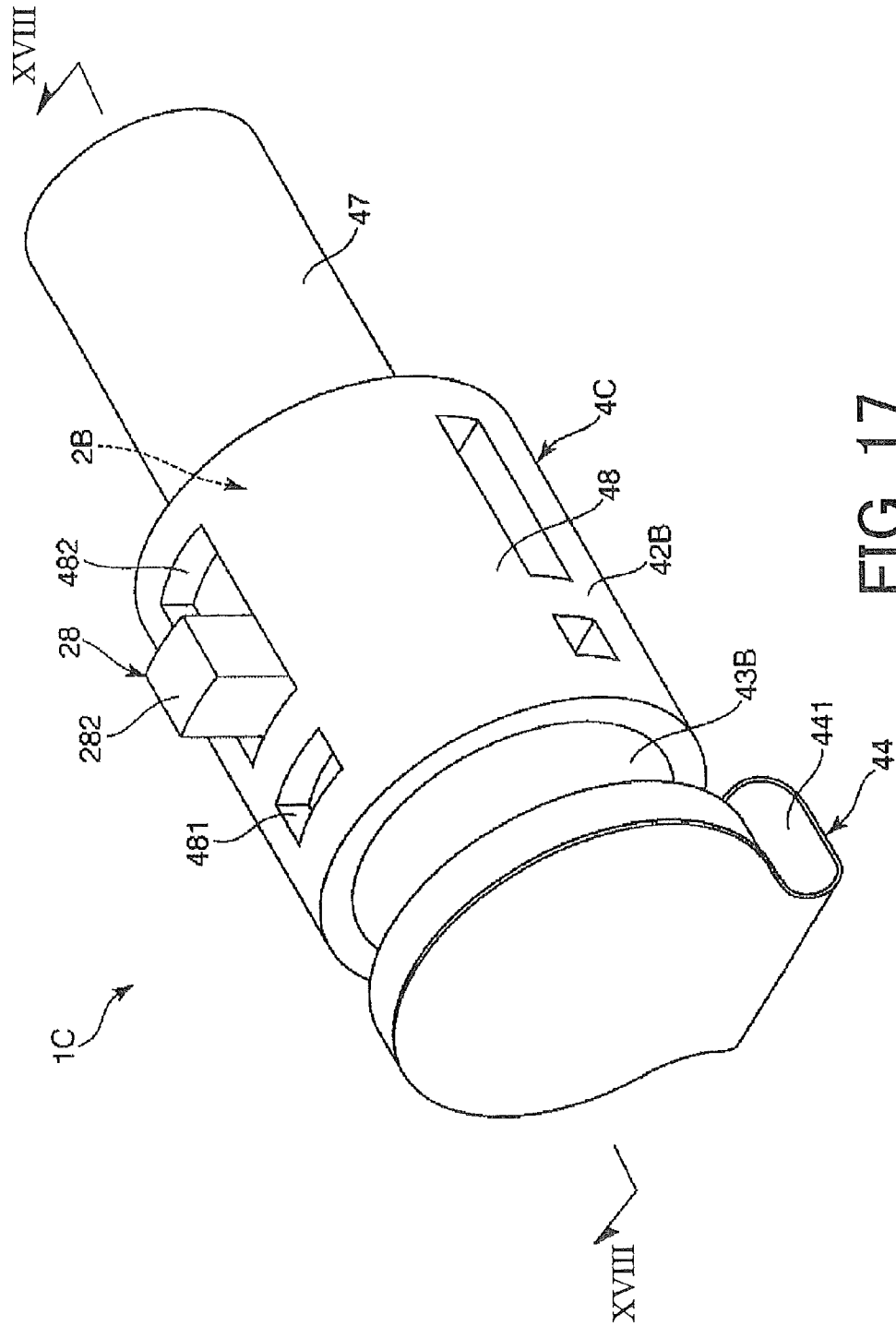

FIG. 17

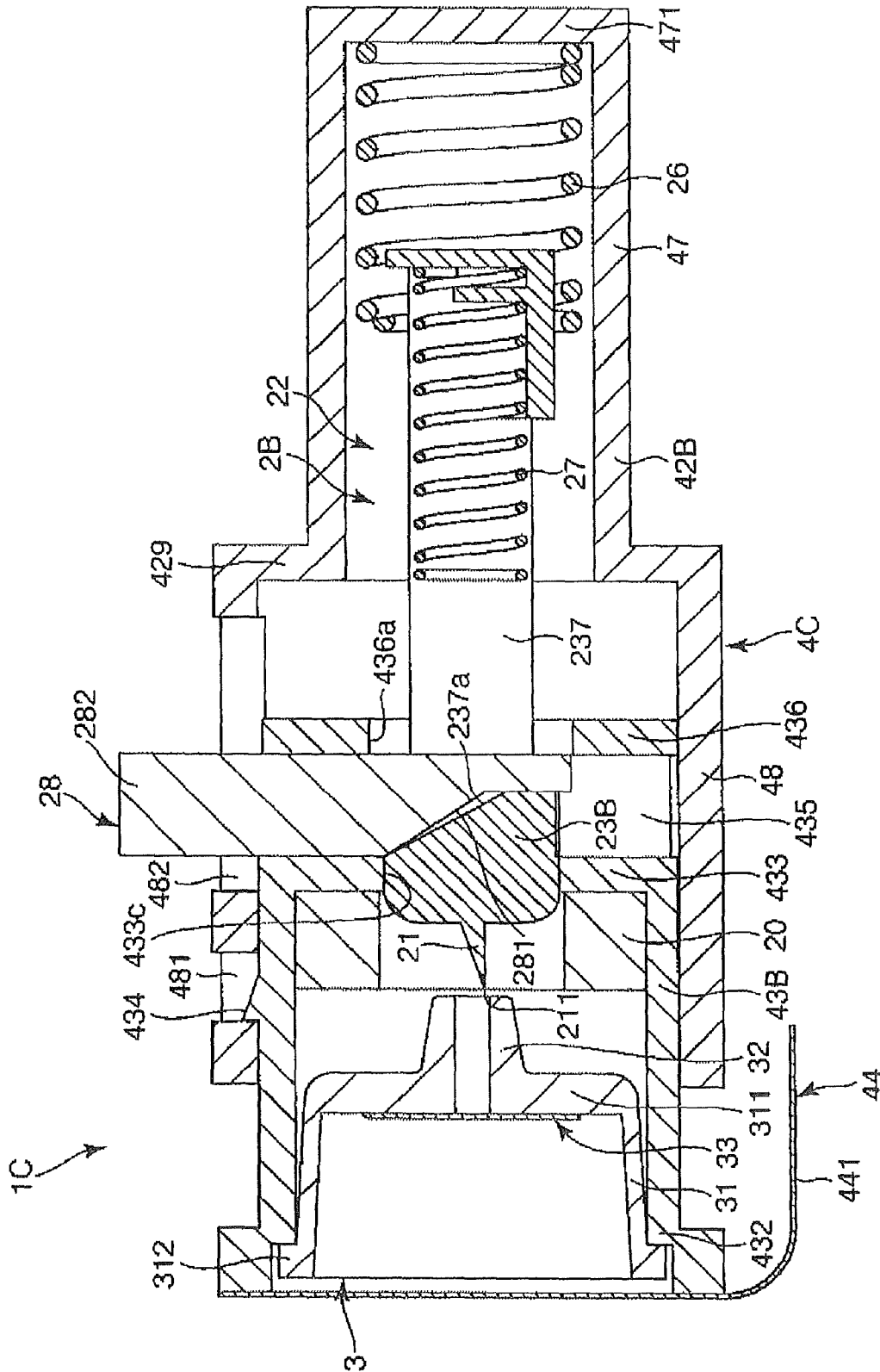

FIG. 18

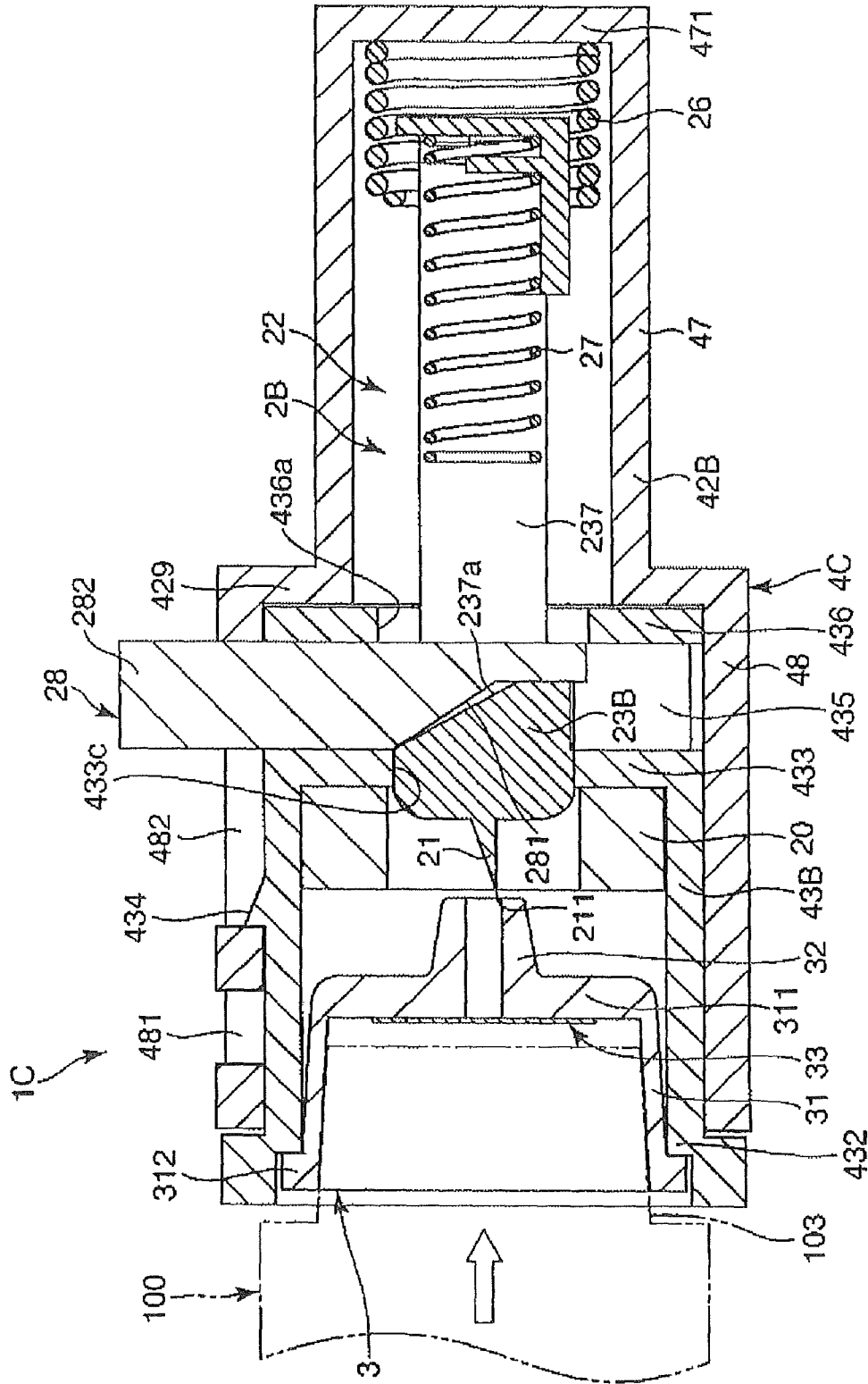

FIG. 19

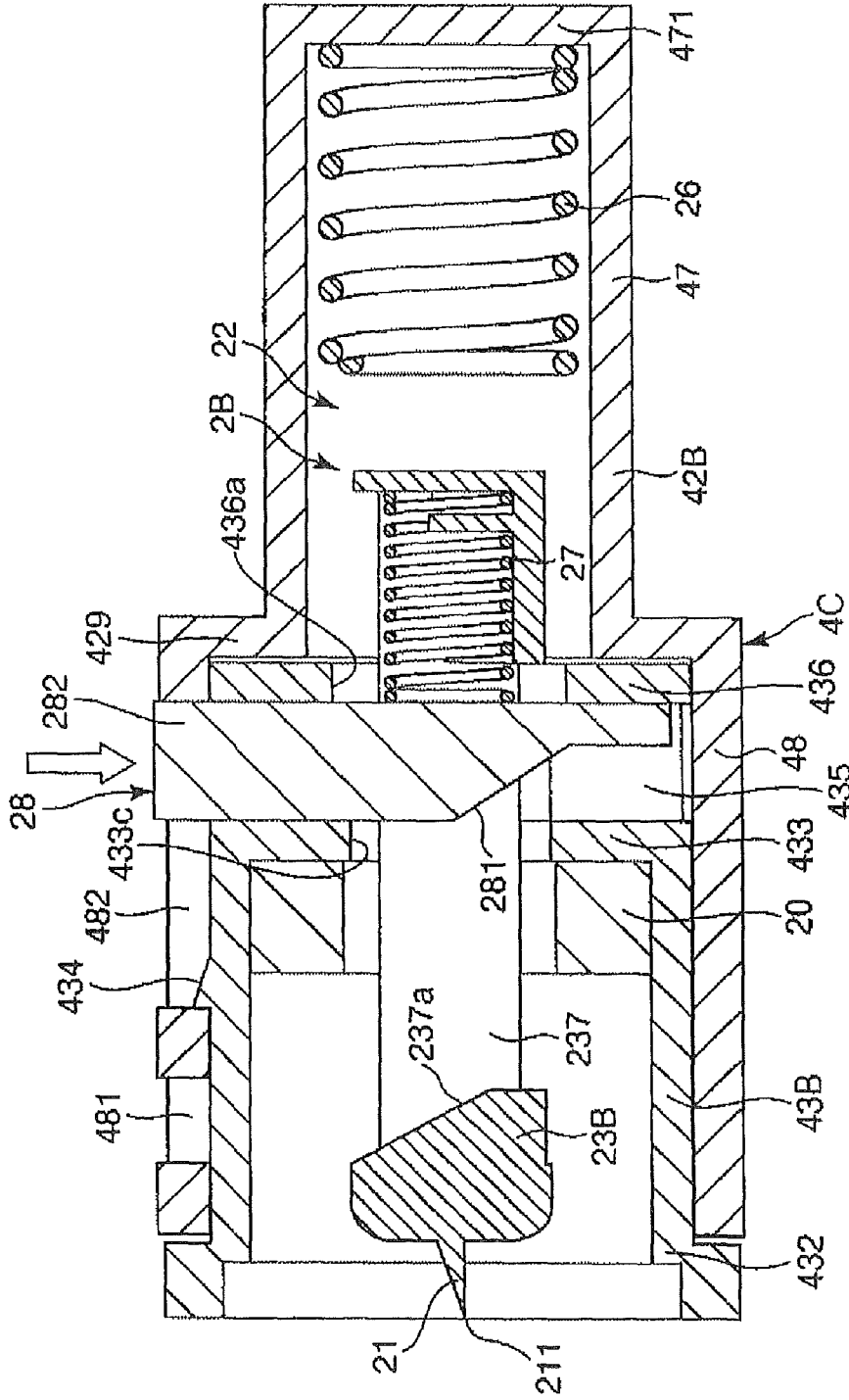

FIG. 20

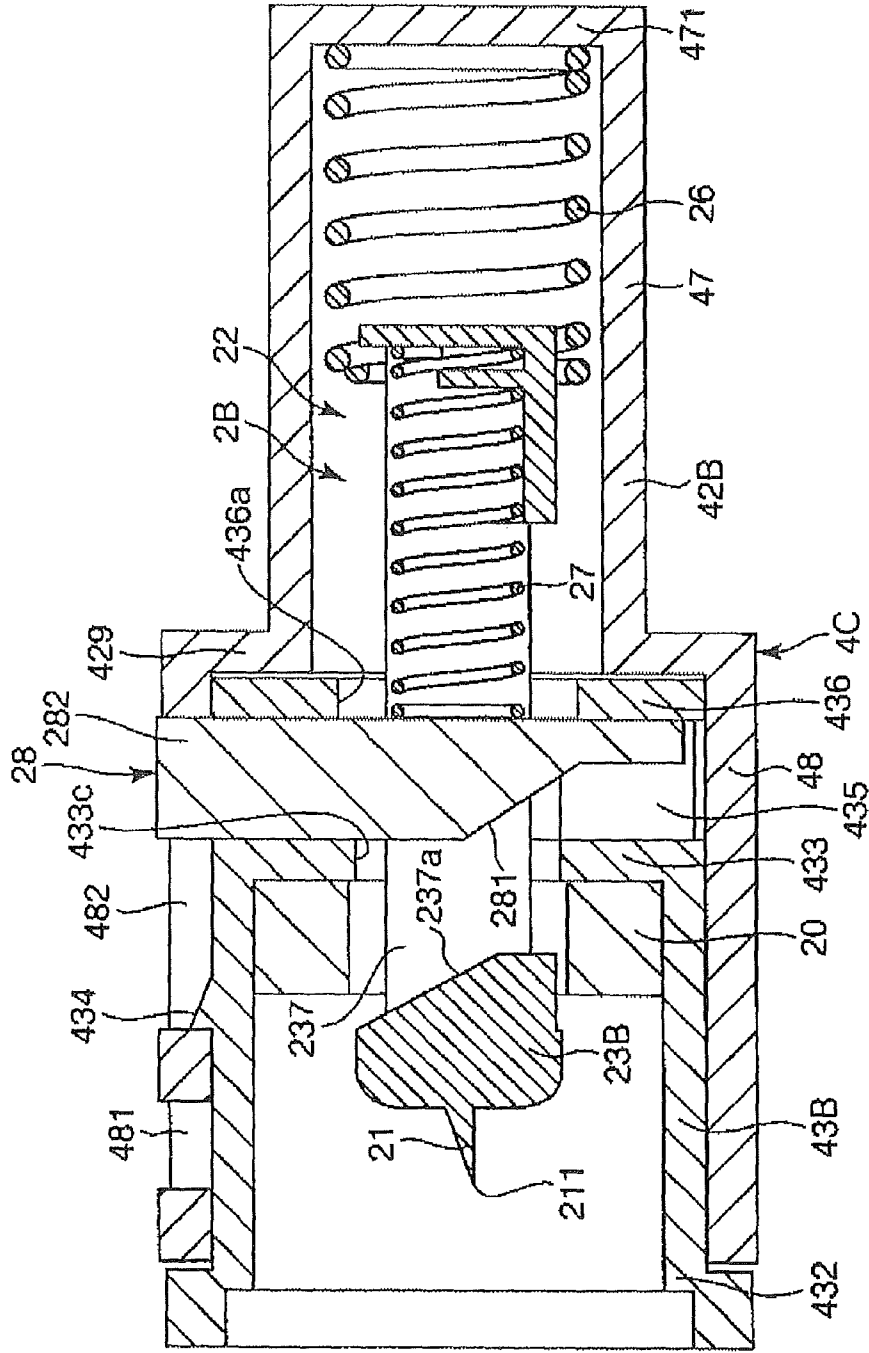

FIG. 21

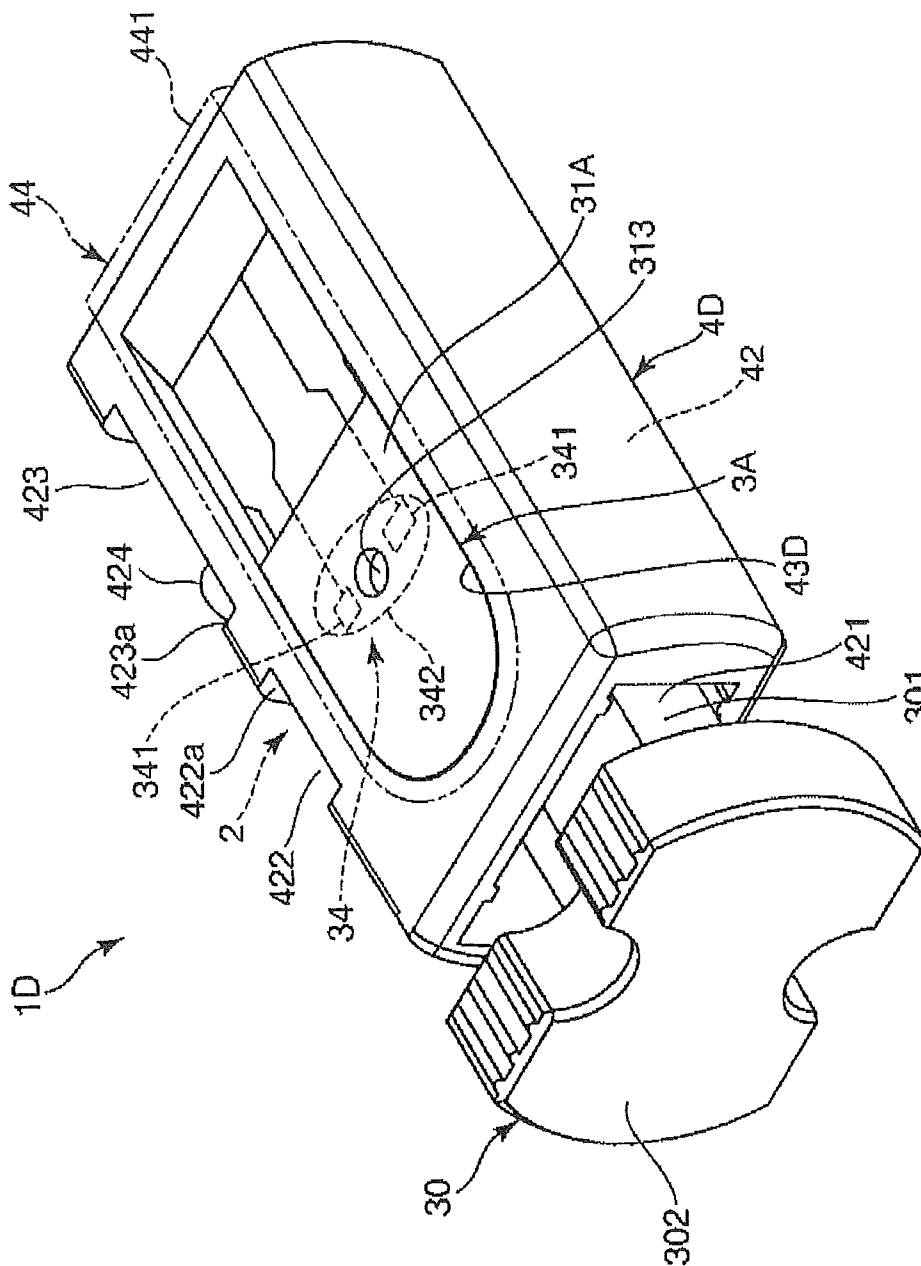

FIG. 22



**BODY FLUID SAMPLING UNIT**

This application is a divisional of U.S. application Ser. No. 11/905,053 filed on Sep. 27, 2007, and claims priority to Japanese Application No. 2006-263547 filed on Sep. 27, 2006, the entire content of both of which is incorporated herein by reference.

**TECHNOLOGICAL FIELD**

The subject matter disclosed herein generally relates to a body fluid sampling unit, and more specifically pertains to a device for obtaining a sample of body fluid such as blood for purposes of detecting a component in the sample.

**BACKGROUND DISCUSSION**

As the population of diabetics has increased, recent recommendations have called for self-monitoring of blood glucose in which daily variations in the blood glucose level of the patient is monitored by the patient himself/herself. Generally speaking, performing blood glucose measurement involves a puncture implement for puncturing skin and a measuring device for sampling the blood flowing out from the skin punctured by the puncture implement and measuring the blood glucose level in the blood.

An example of the puncture implement is disclosed in Japanese Laid-Open Patent Publication No. 2003-502088 and includes a needle, a case in which to movably contain the needle, and a drive mechanism contained in the case together with the needle and operative to move the needle. The puncture implement of this type is discarded after used once.

In addition, the measuring device is ordinarily used in the condition where a sampling implement which has a reagent capable of reaction with glucose and which functions to receive the spot-like deposition of blood (to sample the blood) is mounted thereto. The sampling implement is detachably mounted to the measuring device, and is discarded after one use, like the puncture implement.

In the past, in performing blood glucose measurement (in sampling blood), the puncture implement and the sampling implement have been prepared individually (separately from each other). Therefore, the preparation for blood glucose measurement is troublesome, and it has been difficult to achieve speedy measurement. In short, the operational aspects associated with performing blood glucose measurement have been poor.

**SUMMARY**

According to one aspect, a body fluid sampling unit includes: a puncture mechanism comprising a needle possessing a sharp needle point at a distal end of the needle, and drive means for operating the needle to puncture a living body surface with the needle point; a body fluid sampling implement comprising an introducing section for introducing a body fluid flowing out from a puncture portion of the living body surface punctured with the needle point, a detecting section for detecting a predetermined component in the body fluid introduced through the introducing section, and a mounted section configured to be mounted to a component measuring device for measuring the quantity and/or property of the predetermined component detected by the detecting section; and a container comprising a mechanism containing section containing the puncture mechanism so that the needle point of the puncture mechanism is movable by the drive means, and a sampling implement containing section con-

taining the body fluid sampling implement in a manner allowing the body fluid sampling implement to be removed from the sampling implement containing section. The puncture mechanism is put into a state of being prepared to perform an operation of puncturing the living body surface by removal of the body fluid sampling implement from the sampling implement containing section.

According to another aspect, a body fluid sampling unit comprises: a case on which is supported a movable plate piece; a needle positioned inside the case, the needle possessing a sharp needle point at its distal end for puncturing living body tissue to obtain body fluid; a body fluid sampling implement configured to be mounted on a component measuring device which is adapted to measure a quantity and/or property of a predetermined component of a sample of the body fluid obtained by the puncturing of the living body tissue, the body fluid sampling implement comprising a reagent containing part that includes a reagent adapted to interact with the predetermined component of the sample of the body fluid; a spring positioned to apply a biasing force to the needle urging the needle from a housed position in which the sharp needle point is housed inside the case to a puncturing position in which the sharp needle point is exposed outside the case to puncture the living body tissue; and an engaging piece connected to the needle, the engaging piece being shiftable from an engaged position in which the engaging piece engages the plate piece so that the needle remains in the housed position and the biasing force applied to the needle does not move the needle toward the puncturing position to a released position in which the engaging piece moves out of engagement with the plate piece so that the biasing force applied to the needle moves the needle toward the puncturing position, the engaging piece being movable from the engaged position to the released position in response to movement of the plate piece. The body fluid sampling implement is positioned in the case in contact with the plate piece so that the contact between the plate piece and the body fluid sampling implement prevents a force applied to the plate piece from resulting in the movement of the plate piece which causes the engaging piece to shift from the engaged position to the released position, and the body fluid sampling implement being removable from the case so that the force applied to the plate piece results in the movement of the plate piece which causes the engaging piece to shift from the engaged position to the released position to permit the needle to move toward the puncturing position under the biasing force of the spring.

In accordance with a further aspect, a body fluid sampling unit comprises: a case possessing an interior and an opening at a distal end of the case; a needle positioned in the interior of the case, the needle possessing a sharp needle point at its distal end for puncturing living body tissue to obtain body fluid; a body fluid sampling implement configured to be mounted on a component measuring device which is adapted to measure a quantity and/or property of a predetermined component of a sample of the body fluid obtained by the puncturing of the living body tissue, the body fluid sampling implement comprising a test paper containing a reagent adapted to interact with the predetermined component of the sample of the body fluid; and a spring applying a biasing force to the needle urging the needle from a housed position in which the sharp needle point is housed in the interior of the case to a puncturing position in which the sharp needle point extends distally beyond the opening at the distal end of the case. The body fluid sampling implement is positioned in the case in contact with a portion of the case and being removable from the case so that the body fluid sampling implement is not in contact with the portion of the case, and the needle is

prevented from moving to the puncturing position from the housed position under the biasing force of the spring whenever the body fluid sampling implement is positioned in the case in contact with a portion of the case. The needle is permitted to move from the housed position to the puncturing position under the biasing force of the spring when the body fluid sampling implement is removed from the case so that the body fluid sampling implement is not in contact with the portion of the case.

The body fluid sampling implement is used by being taken out from the sampling implement containing section and being mounted to the component measuring device. The body fluid sampling implement is once mounted to the component measuring device in the state of being contained in the sampling implement containing section, and is thereafter released from the sampling implement containing section and mounted to the component measuring device by spacing the container away from the component measuring device.

The body fluid sampling implement is preferably tentatively fixed to the sampling implement containing section, and a force with which the sampling implement containing section fixes the body fluid sampling implement is smaller than a force of connection between the body fluid sampling implement and the component measuring device.

The puncture mechanism is preferably put into the state of being capable of an operation of puncturing the living body surface, by release of the body fluid sampling implement. The drive means includes a support section for supporting the needle, and a biasing section for biasing the support section, and a biasing force is accumulated in the biasing section by an operation of pressing the body fluid sampling implement against the component measuring device at the time of mounting the body fluid sampling implement to the component measuring device. In addition, the mechanism containing section includes an outer tube, the sampling implement containing section includes an inner tube which is slid inside the outer tube in its longitudinal direction and connected to the outer tube through the puncture mechanism, the body fluid sampling implement is mounted into the component measuring device by pushing, and when the operation of pushing the body fluid sampling implement into the component measuring device is conducted, the inner tube is pushed together with the body fluid sampling implement to move inside the outer tube, whereby a biasing force of the biasing section is accumulated.

The drive means includes a support section for supporting the needle, a biasing section for biasing the support section, and an operating member for displacing the support section so as to bias the biasing section.

The operating member can function as a cap for covering the needle point of the needle and maintaining a sterile state of the needle point. The mounted section has a bottomed tube shape, the introducing section protrudes in a tubular form to the outside from a bottom part of the mounted section, and the detecting section is disposed at the bottom part.

The detecting section includes a test paper carrying a reagent capable of a color reaction with the predetermined component in the body fluid. The detecting section includes at least two electrodes, and a reagent coated part coated with a reagent capable of reacting with the predetermined component in the body fluid to thereby generate a current between the electrodes. The sampling implement containing section has an opening permitting the body fluid sampling implement to be moved in and out therethrough, and has a seal member for sealing the opening in a gas-tight manner in the condition where the body fluid sampling implement is contained in the sampling implement containing section.

According to the disclosure here, the puncture mechanism and the body fluid sampling implement necessary for sampling a body fluid are contained in one case, so that the preparation for the sampling operation can be easily carried out, i.e., excellent operability is attained in sampling a body fluid.

In the body fluid sampling unit described here, the body fluid sampling implement is contained in the case (container) including the puncture mechanism for sampling a body fluid. Therefore, preparation for body fluid sampling and body fluid component measurement can be easily carried out, i.e., the body fluid sampling unit is excellent in operability in performing body fluid sampling and body fluid component measurement.

In addition, the body fluid sampling unit can be mounted to the component measuring device while keeping the body fluid sampling implement contained in the case. Therefore, it is unnecessary to take out the body fluid sampling implement from the case each time of use; thus, the body fluid sampling unit is excellent in operability.

Also, the body fluid sampling unit is labor-saving in operation, since the puncture mechanism is charged and a stand-by condition for puncture is attained simultaneously with the mounting of the body fluid sampling implement to the component measuring device. After the puncture, the body fluid sampling (component measuring) operation can be speedily carried out, since the body fluid sampling implement has already been put into the state of being usable.

In addition, in the body fluid sampling unit, the puncture mechanism cannot be put into the stand-by state for puncture until the body fluid sampling implement is mounted to the component measuring device, i.e., until the body fluid sampling implement is separated from the body fluid sampling unit. Therefore, the sequence of operations such that puncture of a living body surface is conducted after the body fluid sampling implement is mounted to the component measuring device and the preparation for measurement is completed can be easily grasped.

#### BRIEF DESCRIPTION OF THE DRAWING FIGURES

Additional features and aspects of the body fluid sampling unit disclosed here will become more apparent from the following detailed description considered with reference to the accompanying drawing figures briefly described below in which like elements are designated by like reference numerals.

FIG. 1 is a perspective view of a first embodiment of the body fluid sampling unit disclosed herein.

FIG. 2 is a longitudinal cross-sectional view of the body fluid sampling unit shown in FIG. 1 taken along the section line II-II in FIG. 1.

FIG. 3 is a longitudinal cross-sectional view of the body fluid sampling unit showing an operating condition of the body fluid sampling unit during use.

FIG. 4 is a longitudinal cross-sectional view of the body fluid sampling unit showing another operating condition of the body fluid sampling unit during use.

FIG. 5 is a longitudinal cross-sectional view of the body fluid sampling unit showing another operating condition of the body fluid sampling unit during use.

FIG. 6 is a longitudinal cross-sectional view of the body fluid sampling unit showing another operating condition of the body fluid sampling unit during use.

FIG. 7 is a perspective view of a second embodiment of the body fluid sampling unit.

FIG. 8 is a longitudinal cross-sectional view of the body fluid sampling unit shown in FIG. 7 taken along the section line VIII-VIII in FIG. 7.

FIG. 9 is a longitudinal cross-sectional view of the body fluid sampling unit of FIG. 7 showing one operating condition of the body fluid sampling unit during use.

FIG. 10 is a longitudinal cross-sectional view of the body fluid sampling unit showing another operating condition of the second embodiment of the body fluid sampling unit during use.

FIG. 11 is a longitudinal cross-sectional view of the body fluid sampling unit showing another operating condition of the second embodiment of the body fluid sampling unit during use.

FIG. 12 is a perspective view of a third embodiment of the body fluid sampling unit.

FIG. 13 is a longitudinal cross-sectional view of the body fluid sampling unit shown in FIG. 12 taken along the section line XIII-XIII in FIG. 12.

FIG. 14 is a longitudinal cross-sectional view of the body fluid sampling unit of FIG. 12 showing an operating condition of the body fluid sampling unit during use.

FIG. 15 is a longitudinal cross-sectional view of the body fluid sampling unit showing another operating condition of the third embodiment of the body fluid sampling unit during use.

FIG. 16 is a longitudinal cross-sectional view of the body fluid sampling unit showing another operating condition of the third embodiment of the body fluid sampling unit during use.

FIG. 17 is a perspective view of a fourth embodiment of the body fluid sampling unit.

FIG. 18 is a longitudinal cross-sectional view of the body fluid sampling unit shown in FIG. 17 taken along the section line XVIII-XVIII in FIG. 17.

FIG. 19 is a longitudinal cross-sectional view of the body fluid sampling unit of FIG. 17 showing an operating condition of the body fluid sampling unit during use.

FIG. 20 is a longitudinal cross-sectional view of the body fluid sampling unit showing another operating condition of the fourth embodiment of the body fluid sampling unit during use.

FIG. 21 is a longitudinal cross-sectional view of the body fluid sampling unit showing another operating condition of the fourth embodiment of the body fluid sampling unit during use.

FIG. 22 is a perspective view showing a fifth embodiment of the body fluid sampling unit.

#### DETAILED DESCRIPTION

FIGS. 1-6 illustrate one embodiment of the body fluid sampling unit disclosed herein. In the description which follows, for purposes of convenience, the right side in FIGS. 1-6 (and in FIGS. 7-22 also) is referred to as "the proximal end", the left side is referred to as "the distal end", the upper side is referred to as "the upper side" or "upwards", and the lower side is referred to as "the lower side" or "downwards".

The body fluid sampling unit 1 shown in FIG. 1 and FIG. 2 includes a puncture mechanism 2, a tip (body fluid sampling implement) 3, and a case (casing or container) 4 containing the puncture mechanism 2 and the tip 3 collectively therein. The puncture mechanism 2 is configured to puncture a living body surface (skin). In addition, the tip 3 is configured to sample body fluid obtained from a puncture portion of the living body surface punctured by the puncture mechanism 2. The tip 3 is used in the state of being mounted to a component

measuring device 100 for measuring the quantity and/or property of a predetermined component in the body fluid.

The body fluid sampling portion of the living body surface (skin) from which a body fluid sample is obtained is preferably a finger, but may be other portions, for example a hand (the palm, the back of a hand, the side portion of a hand), an arm, a thigh, an earlobe, or the like. The following description describes, as an example, blood as the body fluid, blood glucose as the predetermined component, and a fingertip (finger) as the body fluid sampling portion of the living body.

As shown in FIGS. 2-5, the case 4 is composed of a tubular body. The case 4 is provided with a partition wall 41 partitioning the inner cavity or interior (hollow section) of the case 4 into a mechanism containing section 42 located on the distal end side, and a sampling implement containing section 43 located on the proximal end side.

The case 4 can be said to include the mechanism containing section 42 possessing a bottomed tube shape, and the sampling implement containing section 43 (extension section) extending (projecting in a tubular form) from the bottom part of the mechanism containing section 42 toward the proximal end side.

In the illustrated embodiment, the case 4 is configured so that the mechanism containing section 42 and the sampling implement containing section 43 are positioned coaxially. This helps ensure that, at the time of using the body fluid sampling unit 1, the operator can easily recognize or understand the position at which the needle point 211 protrudes and the position where blood is spotted, which is advantageous in that a puncture at a unintended position and/or a failure in realizing the spot-like deposition of blood can be inhibited or prevented.

One puncture mechanism 2 is contained in the mechanism containing section 42 of the case 4, and one tip 3 is contained in the sampling implement containing section 43 of the case 4. The body fluid sampling unit 1 is thus relatively small in size and suitable, for example, for carrying the body fluid sampling unit 1. In addition, compared to needing to prepare four articles or parts as in known devices, only two articles need to be prepared. This helps facilitate handling and allows relatively easy measurement in a limited space, thus advantageously lessening the burden on the operator.

The mechanism containing section 42 has a distal end opening 421 which opens at the distal end of the mechanism containing section 42 (the case 4) on the side opposite the partition wall 41. As shown in FIG. 4, the distal end opening 421 functions as a protrusion opening through which the needle point 211 of the puncture mechanism 2 protrudes at the time of puncture of a fingertip.

In addition, the mechanism containing section 42 has a first opening (first engaging part) 422 and a second opening (second engaging part) 423 where upper-side parts of the wall of the case 4 are provided with through openings. The second opening 423 is disposed on the proximal end side of the first opening 422.

The first opening 422 is roughly quadrangular in shape when viewed from the upper side. In addition, the second opening 423 is U-shaped when viewed from the upper side. As shown in FIGS. 2, 3 and 4, an engaging piece 25 associated with the puncture mechanism 2 engages either the first opening 422 or the second opening 423 according to the operating condition of the puncture mechanism 2.

A plate piece (tongue piece) 424 supported at its proximal end is formed on the inside of the second opening 421. The plate piece 424 ensures that the engaging piece 25 can be disengaged from the second opening 423 by depressing downward a distal end part of the plate piece 424 in the

condition where the engaging piece **25** is in engagement with the second opening **423** (see FIGS. **3** and **4**). Therefore, the plate piece **424** serves as an operating section for disengaging the engaging piece **25** from the second opening **423**.

As shown in FIG. **2**, the sampling implement containing section **43** which is adapted to contain the tip **3** is located on the proximal end side (on the side opposite to the protrusion direction of the needle point **211**) of the mechanism containing section **42**.

The sampling implement containing section **43** has a proximal end opening **431** opening at the proximal end of the sampling implement containing section **43** (the case **4**). Through the proximal end opening **431**, the tip **3** can be contained (inserted) into the sampling implement containing section **43**, and the tip **3** contained in the sampling implement containing section **43** can be taken out.

In addition, a membrane member (seal member) **44** for covering the proximal end opening **431** is fixed to the proximal end opening **431** preliminarily (in the unused state of the body fluid sampling unit **1**). The method of fixing in this case is not particularly limited; for example, the fixation may be made by adhesion (adhesion with an adhesive or by use of a solvent).

The membrane member **44** is for sealing the proximal end opening **431** in a gas-tight manner. This makes it possible to maintain the cleanliness of the tip **3** contained in the sampling implement containing section **43**. Therefore, the membrane member **44** has the function as a state maintaining means for maintaining the clean state of the tip **3**. In addition, the membrane member **44** can prevent the tip **3** contained in the sampling implement containing section **43** from deteriorating with time due to moisture absorption. Therefore, the membrane member **44** has also the function as a moisture proofing means for the tip **3**.

The membrane member **44** is peeled (released) from the proximal end opening **431** at the time of taking out the tip **3** contained in the sampling implement containing section **43**. At the time of peeling the membrane member **44**, the operation (peeling operation) can be easily carried out by gripping (pinching) a tab (edge part) **441** of the membrane member **44**.

In addition, the sampling implement containing section **43** has a stepped part **432** varied in inside diameter (enlarged in diameter), on the distal end side and in the vicinity of the proximal end opening **431**. As shown in FIG. **2**, the tip **3** contained in the sampling implement containing section **43** has a part (flange part **312**) thereof in abutment on the stepped part **432**. This makes it possible to prevent the tip **3** from being inserted excessively into the sampling implement containing section **43** and, therefore, to easily take out the tip **3** contained in the sampling implement containing section **43**.

The material constituting the case **4** as above is not particularly limited, and, for example, a resin material can be used. Examples of the resin material which can be used include thermoplastic resins ordinarily used in injection molding, such as ABS resin, AS resin, polyethylene, polypropylene, polystyrene, polyvinyl chloride, polyvinylidene chloride resin, polyphenylene oxide, thermoplastic polyurethane, polymethylene methacrylate, polyoxyethylene, fluoro-resin, polycarbonate, polyamide, acetal resin, acrylic resin, polyethylene terephthalate, etc.; and thermosetting resins such as phenolic resin, epoxy resin, silicone resin, unsaturated polyester, etc.

Besides, a desiccant agent **20** is contained in the sampling implement containing section **43**, together with the tip **3**. The drying agent **20** has the function of preventing moisture

absorption of the tip **3** in the sampling implement containing section **43**, i.e., the function of maintaining the dry state of a test paper **33**.

The drying agent **20** is ring-like in outer shape, and is disposed concentrically with the sampling implement containing section **43**. In addition, the drying agent **20** may be fixed to or may not be fixed to the sampling implement containing section **43**.

As the drying agent **20**, various drying agents can be used. A preferable example of the drying agent **20** is composed of at least one selected from the group consisting of silica, alumina, synthetic zeolites such as Molecular Sieves, etc., natural zeolites such as mordenite, erionite, etc., chlorides of alkaline earth metals such as calcium chloride, magnesium chloride, etc., and clay minerals such as pearlite, activated white clay, etc.

As above-mentioned, one puncture mechanism **2** is contained in the mechanism containing section **42**. The puncture mechanism **2** includes a needle **21**, and a drive means (drive mechanism) **22** for moving the needle **21**.

The needle **21** is composed, for example, of a long solid member (or hollow member) formed of a metallic material such as stainless steel, aluminum, aluminum alloy, titanium, titanium alloy, etc., and is provided at its distal end with a sharp needle point (blade edge) **211**. The needle point **211** is used to puncture the surface (skin) of a fingertip.

The drive means **22** includes a support section **23** for supporting the needle **21**, a coil spring (biasing section) **24** for biasing the support section **23**, and the engaging piece **25** capable of engaging with the first opening **422** and the second opening **423** of the case **4**.

The support section **23** can be displaced into any of an initial position (the state shown in FIGS. **2** and **5**), a stand-by position (the state shown in FIG. **3**), and a puncture position (the state shown in FIG. **4**). The "initial position" means a position where a biasing force of the coil spring **24** does not act on the support section **23**. In addition, the "stand-by position" means a position where the biasing force is accumulated in the coil spring **24** and preparation for puncture of a fingertip by the needle **21** is made. Further, the "puncture position" means a position where puncture by the needle **21** (needle point **211**) is conducted.

The support section **23** includes a body part **231** angular U shaped in longitudinal sectional shape, a distal end projected part **232** projectingly formed at the distal end of the body part **231**, and a proximal end projected part **233** projectingly formed on the inside of the body part **231**.

The body part **231** is disposed in the mechanism containing section **42** so that the opening (opened) side (the opening side of the angular U shape) thereof is disposed on the proximal end side. In addition, the body part **231** can be slid inside the mechanism containing section **42** along the longitudinal direction thereof, by the biasing force of the coil spring **24**.

The distal end projected part **232** projected in the direction of the distal end is provided on the side, opposite to the angular U-shaped opening side, of the body part **231**. The distal end projected part **232** is cylindrical in outer shape. The needle **21** is supported by (fixed to) the distal end projected part **232**, concentrically with the distal end projected part **232**.

In addition, the body part **231** is provided, on the opposite side of the distal end projected part **232**, with the proximal end projected part **233** projected in the direction of the proximal end. The proximal end projected part **233** is cylindrical in outer shape. A distal end section of the coil spring **24** is fitted over the proximal end projected part **233**.

The proximal end projected part **233** is provided at its outer peripheral part with a plurality of pawl parts **234** projecting in

the outer radial direction. Each of the pawl parts **234** is wedge-shaped so that its height gradually increases as one goes toward the distal end. Each of the pawl parts **234** is engagement with the distal end section of the coil spring **24**. This prevents the proximal end projected part **233** from slipping off the distal end section of the coil spring **24**, i.e., this makes it possible to support and fix the distal end section of the coil spring **24**.

In addition, a proximal end section of the coil spring **24** is supported by a projected part **411** projectingly formed at the partition wall **41** of the case **4**. The projected part **411** is opposed to the proximal end projected part **233**, and is formed at the partition wall **41** of the case in the form of projecting in the direction of the distal end. The projected part **411** is cylindrical in outer shape. A proximal end section of the coil spring **24** is fitted over the projected part **411**.

The projected part **411** is provided at its outer peripheral part with a plurality of pawl parts **412** projecting in the outer radial direction. Each of the pawl parts **412** is wedge-shaped so that its height gradually increases as one goes toward the proximal end. Each of the pawl parts **412** is in engagement with the proximal end section of the coil spring **24**. This prevents the projected part **411** from slipping off the proximal end section of the coil spring **24**, i.e., this makes it possible to support and fix the proximal end section of the coil spring **24**.

At a proximal end part of the body part **231**, the engaging piece **25** cantilever supported by the proximal end part is formed as one body with the body part **231**. Of the engaging piece **25**, the proximal end is a fixed end supported by the body part **231**, and the distal end is a free end. The engaging piece **25** is an elastic piece having elasticity.

The engaging piece **25** is provided with a lock part (engaging part) **251** on the free end side. The lock part **251** is a portion having an upwardly projecting block-like shape.

The material constituting the support section **23** (inclusive of the engaging piece **25**) is not particularly limited. For example, materials similar to those which can be used to form the case **4** can be used to fabricate the support section **23**.

In addition, the material constituting the coil spring **24** is not limited to a specific material. Examples of materials which can be used individually or in combination include various metallic materials, various plastics and the like.

The operation of the puncture mechanism **2** configured in the manner described above is as follows.

As shown in FIG. 2, when the support section **23** is in its initial position, i.e., when the puncture mechanism **2** is in an unused state, the coil spring **24** has a natural length. This prevents the needle **21** (support section **23**) from unintended movement so that accidental sticking by the needle point **211** due to movement of the needle **21** can be relatively reliably prevented.

In addition, the needle **21** is covered by an operating member (cap) **30** which will be described later. This cap **30** can help prevent accidental sticking by the needle point **211** from occurring.

The engaging piece **25** has its lock part **251** locked to a proximal end part **422a** of the first opening **422**. This maintains the support section **23** in the stand-by position, i.e., this can prevent the support section **23** from unintended movement (e.g., toward the proximal end side).

When the support section **23** is pushed in the direction of the proximal end starting from the condition shown in FIG. 2, the lock part **251** of the engaging piece **25** comes over the proximal end part **422a** of the first opening **422**, against the elastic force (biasing force) of the engaging piece **25**. Attendant on the pushing operation applied to the support section **23**, the lock part **251** is moved further in the direction of the

proximal end, is brought into the second opening **423**, and is engaged with a distal end part **423a** of the second opening **423** (see FIG. 3). In addition, an upper surface of the engaging piece **25** comes into contact with the distal end of the plate piece **424**.

At this time, the proximal end of the body part **231** of the support section **23** abuts on the partition wall **41**. As a result, the movement of the support section **23** in the proximal end direction end is stopped.

In addition, the coil spring **24** is compressed (contracts) since the spacing between the body part **231** of the support section **23** and the partition wall **41** is reduced. As a result, a biasing force is accumulated in the coil spring **24**.

With the operation described above starting from the initial position, the support section **23** is displaced into the stand-by position, i.e., the puncture mechanism **2** (body fluid sampling unit **1**) is put into the state shown in FIG. 3. When the puncture mechanism **2** is brought into the state shown in FIG. 3, the operating member **30** is detached from the puncture mechanism **2**.

When the plate piece **424** is depressed downward against the biasing force of the engaging piece **25** starting from the condition shown in FIG. 3, the lock part **251** of the engaging piece **25** and the distal end part **423a** of the second opening **423** are disengaged from each other. At this time, the compressed state of the coil spring **24** is cleared, and the coil spring **24** extends in the direction of the distal end. This displaces the support section **23** into the puncture position so that the needle point **211** protrudes from the distal end opening **421**, i.e., the puncture of a fingertip is enabled as shown in FIG. 4.

Thereafter, the coil spring **24** returns to the natural length, so that the support section **23** is returned to the initial position as seen in FIG. 5.

At this time, the needle point **211** of the needle **21** is not protruding from the distal end opening **421**. That is, upon returning to the initial position shown in FIG. 5, the needle point **211** is located inside the mechanism containing section **42**. By virtue of this, accidental sticking by the needle point **211** can be prevented.

With the operation of the puncture mechanism **2** described above, the needle **21** (support section **23**) is relatively reliably displaced to be located in the initial position, the stand-by position, the puncture position and the initial position, in this order. The puncture of the fingertip can thus be carried out relatively assuredly. In addition, the position of the needle **21** can be grasped (recognized) according to the position of the engaging piece **25** relative to the case **4**, so that it is possible to perform a safe puncture operation, namely, to prevent accidental sticking.

Thus, the body fluid sampling unit **1** possesses excellent operational characteristics in sampling blood by puncture of a fingertip.

As shown in FIGS. 1-3, the operating member or cap **30** is detachably mounted to the puncture mechanism **2** (support section **23**). The operating member **30** is so configured that in the condition where it is mounted to the support section **23**, the support section **23** can be displaced from the initial position into the stand-by position, i.e., the support section **23** can be operated, by use of the operating member **30**.

The operating member **30** includes a connection section **301** to be connected to the support section **23**, and a grip section **302** formed at a distal end part of the connection section **301**.

The grip section **302** is a portion which is gripped at the time of operating the operating member **30**. The grip section **302** is plate-like in shape.

## 11

The connection section **301** is a portion which is cylindrical in outer shape. The connection section **301** is formed at the proximal end face of the grip section **302** so that the connection section **301** and the grip section **302** are integrally formed as a unitary one-piece body.

By pushing the operating member **30** in the proximal direction, the support section **23** can be displaced or moved from the initial position to the stand-by position relatively easily and assuredly.

In addition, the operating member **30** is detached (released) from the support section **23** when its operation is completed, i.e., when the support section **23** is displaced from the initial position into the stand-by position. This makes it possible to prevent the operating member **30** from obstructing the subsequent operation of the body fluid sampling unit **1**, i.e., the puncture operation applied to the fingertip.

In addition, the connection section **301** is provided with a needle containing section **303** composed of a hollow section opening at the proximal end. In the condition where the operating member **30** is mounted to the support section **23**, the needle **21** as a whole is contained in (covered by) the needle containing section **303**. This helps maintain the sterile state of the needle **21**. Therefore, the operating member **30** (needle containing section **303**) functions also as a state maintaining means (cap) for maintaining the sterile state of the needle **21**. In addition, since the needle **21** is entirely contained, accidental sticking by the needle point **211** can be prevented securely.

Examples of the material constituting the operating member **30** include, for example, materials similar to those which can be used to form the case **4** as mentioned above.

As shown in FIG. 2, where the body fluid sampling unit **1** is in the unused state, the tip **3** is contained in the sampling implement containing section **43**. At the time of sampling blood by use of the tip **3**, the tip **3** is taken out of the sampling implement containing section **43** and mounted to the component measuring device **100** as shown in FIG. 6.

As shown in FIGS. 2 and 6, the tip **3** includes a tip body (mounted section) **31**, an introducing section **32** projectingly formed at the tip body **31**, and a test paper **33** as a detecting section disposed in the tip body **31**.

The tip body **31** is a portion to be mounted to the component measuring device **100** (see FIG. 6). The tip body **31** has a bottomed cylindrical shape. In the condition where the tip body **31** (tip **3**) is mounted to the component measuring device **100**, the inner peripheral part of the tip body **31** and the outer peripheral part of a tip mounting section **103** of the component measuring device **100** to be described later are fitted to or engaged with each other as shown in FIG. 6.

In addition, the outer peripheral part of the tip body **31** is provided near its proximal end part with a flange part **312** steeply enlarged in outside diameter. As mentioned previously, in the condition where the tip **3** is contained in the sampling implement containing section **43**, the flange part **312** abuts on the stepped part **432** of the sampling implement containing section **43**.

The introducing section **32** is a portion for introducing to the test paper **33** the blood flowing out from the puncture portion of a skin punctured by the needle point **211**. The introducing section **32** is provided at a bottom part **311** of the tip body **31**, and is composed of a tubular body projecting in the direction of the distal end (outwards). Blood passes through a hollow section or through hole of the tubular body.

The test paper **33** is disposed on the proximal end side of the bottom part **311** of the tip body **31**. The test paper **33** is a reagent carrying part of the tip **3** which carries a reagent

## 12

capable of a color reaction with glucose in blood. By this, the glucose in the blood introduced through the introducing section **32** is detected.

The test paper **33** has the reagent (coloring reagent) carried by (impregnating) a carrier capable of absorbing blood. The carrier is preferably composed of a porous sheet.

The use of the carrier composed of a porous sheet helps ensure that, in the case where the reagent with which to impregnate the carrier is a reagent system involving a process of using oxygen such as an oxidase reaction, sufficient supply of oxygen from the atmospheric air is secured after blood is spread on the test paper **33** so that the reaction can be made to proceed swiftly. Therefore, the coloring condition can be detected without removal of the blood or a filtered component thereof (red blood cell, etc.).

Examples of the carrier composed of a porous sheet include non-woven fabric, woven fabric, stretched sheet, membrane filter, and filter paper. Examples of the material constituting the carrier include polyesters, polyamides, polyolefins, polysulfones, celluloses, silicates, and fluororesins. Specific examples of the material include polyethylene terephthalate, polybutylene terephthalate, polyether-sulfone, nitrocellulose, cellulose, glass, and polytetrafluoroethylene (Teflon (registered trademark)).

The material constituting the carrier is preferably a material produced in the state of being impregnated with an aqueous solution with the reagent dissolved therein, or is a hydrophilic material or a material treated to be hydrophilic so as to ensure speedy absorption and spreading of blood.

In the case of measurement of blood glucose level, examples of the reagent carried by the test paper **33** include glucose oxidase (GOD), peroxidase (POD), and chromogenic agents (coloring reagents) such as 4-aminoantipyrine, N-ethyl-N-(2-hydroxy-3-sulfopropyl)-m-toluidine. Other than these, examples of the reagent include those capable of reacting with blood component, such as ascorbic acid oxidase, alcohol oxidase, cholesterol oxidase, etc. and the same chromogenic agents (coloring reagents) as above, according to the component to be measured. Further, a buffer such as a phosphoric acid buffer may be contained in the reagent. Incidentally, the kinds and components of the reagent are naturally not limited to these.

By way of example, the tip **3** can be made of materials similar to those which can be used to form the case **4** as discussed above.

As described above, the tip **3** is used by being taken out from the sampling implement containing section **43** and mounted to the component measuring device **100**. The component measuring device **100** to which the tip **3** is mounted is described below.

As shown in FIG. 6, the component measuring device **100** has a tubular tip mounting section **103** to which the tip **3** is detachably mounted. A light emitting element (light emitting diode) **101** and a light receiving element (photo-diode) **102** are provided in the vicinity of the proximal end of the tip mounting section **103**. The light emitting element **101** emits pulsed light at a predetermined time interval, for example.

In addition, the component measuring device **100** has a control means (not shown) composed of a micro-computer. The control means incorporates an arithmetic unit for computing the glucose content based on a signal from the light receiving element **102**.

The component measuring device **100** is configured to perform measurement after the tip **3** is mounted to the tip mounting section **103** and blood is supplied to the test paper **33** in the tip **3**.

13

In other words, first, with the light emitting element **101** in the component measuring device **100** turned ON, light emitted from the light emitting element **101** is radiated onto the test paper **33** in the tip **3**, whereby reflected light is obtained. The intensity of the reflected light corresponds to the intensity of coloring of the test paper **33**, i.e., to the quantity (concentration) of glucose in the blood. The reflected light is received by the light receiving element **102** where it undergoes photoelectric conversion. An analog signal corresponding to the quantity of light received is outputted from the light receiving element **102**, the analog signal is converted into a digital signal, which is inputted to the control means where desired arithmetic processing, correction processing and the like are conducted, and the quantity of glucose in the blood is quantized (blood glucose level is determined).

The tip **3** is contained in the sampling implement containing section **43** when the body fluid sampling unit **1** is in the unused state. The tip **3** in this instance is tentatively fixed to, or contained in, the sampling implement containing section **43**. Here, the expression "tentatively fixed" means the condition where the tip **3** is prevented from being involuntarily released from the sampling implement containing section **43** and where the tip **3** can be taken out as required.

With the tip **3** thus tentatively fixed and contained in the sampling implement containing section **43**, an outer peripheral part of the tip **3** and an inner peripheral part of the sampling implement containing section **43** are fitted to each other as shown in FIG. 2. The fitting force (fixing force) exerted on the tip **3** from the sampling implement containing section **43** is set to be smaller than the fitting force (connecting force) exerted on the tip **3** by the component measuring device **100** (the tip mounting section **103**).

In addition, in order to take out the tip **3** thus tentatively fixed, the tip mounting section **103** of the component measuring device **100** is pushed into the tip body **31** to once fit (connect) them to each other, and thereafter the case **4** is pulled (spaced away) in the direction of the distal end relative to the component measuring device **100**. The tip **3** is thus securely taken out (released) in the direction of the proximal end from the sampling implement containing section **43**, and is assuredly mounted to the component measuring device **100**.

Thus, in the body fluid sampling unit **1**, the operation in which the tip **3** is mounted to the component measuring device **100** is utilized also as the operation in which the tip **3** is taken out from the sampling implement containing section **43**. The unit thus possesses excellent operational aspects.

The tip body **31** is tubular (bottomed cylindrical) in shape. Therefore, when the dimensional tolerance associated with fitting the tip body **31** and the sampling implement containing section **43** is appropriately set, the fitting force therebetween can be easily modified to a desired magnitude. In addition, when the dimensional tolerance in fitting the tip body **31** and the tip mounting section **103** is appropriately set, the fitting force therebetween can be relatively easily modified to a desired magnitude.

By virtue of this, the relationship in magnitude between the former fitting force (fitting force between the tip body **31** and the sampling implement containing section **43**) and the latter fitting force (fitting force between the tip body **31** and the tip mounting section **103**) can be assuredly set so as to satisfy the relationship of [the former fitting force] < [the latter fitting force]. Therefore, the tip **3** can be taken out from the sampling implement containing section **43** more securely and reliably, and can be mounted to the component measuring device **100** more assuredly.

14

A method of using the body fluid sampling unit **1** (i.e., the method of sampling blood and measuring the blood glucose level of the blood by use of the body fluid sampling unit **1**) is as follows.

First, the body fluid sampling unit **1** is prepared in the manner shown in FIGS. 1 and 2. The body fluid sampling unit **1** contains one puncture mechanism **2** for puncturing a fingertip and one tip **3** for sampling blood from the puncture portion which are necessary for measurement of blood glucose level. Therefore, preparation for measurement of blood glucose level is relatively easy to carry out.

Next, the tab **441** of the membrane member **44** is gripped and the membrane member **44** is peeled off. Then, as mentioned above, the tip **3** contained in the sampling implement containing section **43** is pushed into the component measuring device **100** to connect them, whereby the tip **3** is mounted to the component measuring device **100**. The operation of mounting the tip **3** is thus relatively easy to carry out.

Subsequently, the operating member **30** is pushed relative to the body fluid sampling unit **1** from which the tip **3** has been taken out, whereby the support section **23** of the puncture mechanism **2** is displaced from the initial position into the stand-by position (see FIG. 3).

Next, the operating member **30** in which the needle point **21** is sealed is taken off (e.g., by twisting), and the distal end opening **421** of the case **4** is brought into contact with the fingertip. In this condition, the plate piece **424** is depressed downward. This displaces the support section **23** from the stand-by position into the puncture position, whereby puncture of the fingertip is effected as shown in FIG. 4. By this, puncture of the fingertip by the puncture implement **3** is achieved, and a minute amount (for example, 1  $\mu$ L or less) of blood flows out (is discharged) from the puncture portion onto the skin. The support section **23** thereafter returns to the initial position as indicated in FIG. 5.

Subsequently, the body fluid sampling unit **1** from which the tip **3** has been taken out is spaced away from the puncture portion (fingertip), and the introducing section **32** of the tip **3** mounted to the component measuring device **100** is brought into contact with the puncture portion (blood). The blood at the fingertip passes through the introducing section **32** by capillary action and is supplied to the test paper **33**, for example so that the blood spreads on the test paper **33**.

Attendant on the supply of the blood onto the test paper **33**, glucose in the blood and the reagent carried by the test paper **33** react with each other, resulting in coloring of the test paper **33** according to the quantity of glucose.

The intensity of coloring of the test paper **33** is optically measured by the component measuring device **100** as above-mentioned, whereby the quantity of glucose in the blood (blood glucose level) is determined.

After the measurement is finished, the tip **3** is detached from the tip mounting section **103**. The used tip **3** thus detached is discarded. In discarding the used tip **3**, the tip **3** may be again contained into the sample implement containing section **43** and discarded together with the puncture mechanism **2**. This makes it possible to prevent contamination with the blood adhering to (remaining in or on) the tip **3**.

Thus, in the body fluid sampling unit **1**, the puncture mechanism **2** is brought into puncture of the fingertip in the condition where the tip **3** is released. This makes it possible to recognize the use of the tip **3** after the puncturing operation, and to relatively easily grasp (understand) the sequence of operations of the body fluid sampling unit **1**. This is extremely effective, for example, for a beginner with respect to the use of the body fluid sampling unit **1**. In other words, the beginner



who uses the body fluid sampling unit **1** for the first time can correctly operate (use) the body fluid sampling unit **1**.

In addition, the body fluid sampling unit **1** is used in relation to the puncture portion punctured by the puncture mechanism **2** so that the blood discharged from the (same) puncture portion is sampled by the tip **3**. With the body fluid sampling unit **1** used in this manner, the sequence of operations of the body fluid sampling unit **1** can be easily grasped. Therefore, the body fluid sampling unit **1** is excellent in operability.

In addition, after the puncture, the blood sampling operation (blood glucose level measuring operation) can be relatively speedily carried out since the tip **3** has already been put into a usable state, i.e., the tip **3** has already been mounted to the component measuring device **100**.

In addition, in the body fluid sampling unit **1**, the direction in which the tip **3** is taken out and the direction of puncture by (the moving direction of) the needle **21** are opposite to each other.

Also, the tip **3** is contained in the case **4** in which the puncture mechanism **2** is contained, together with the puncture mechanism **2**. This helps ensure that preparation of a member for containing the tip **3** separately from the case **4** can be omitted, and so the body fluid sampling unit **1** is relatively simple in configuration.

FIGS. 7-11 illustrate a second embodiment of the body fluid sampling unit. The following description of the second embodiment primarily discusses aspects or features of this embodiment that differ from the embodiment described above. Features and aspects of the second embodiment that are the same as the earlier embodiment are designated by the same reference numeral and a detailed description of such features is not repeated.

This second embodiment is the same as the first embodiment, except for the configuration of the case. The case **4A** of the body fluid sampling unit **1A** shown in FIGS. 7-10 includes a first opening **45** formed by opening an upper-side part of a tube wall ranging from the mechanism containing section **42** to the sampling implement containing section **43**. The first opening **45** is roughly rectangular in shape when viewed from the upper side.

In addition, the first opening **45** is provided with a plate piece **46** covering the first opening **45**. The plate piece **46** is smaller than the first opening **45**, when viewed from the upper side. This ensures that a distal end side part (hereinafter referred to as "small opening **451**") of the first opening **45** is left open.

As shown in FIGS. 8-10, the plate piece **46** is supported by a partition wall **41** at an intermediate part thereof. This ensures that a proximal end part **461** of the plate piece **46** can be depressed downward (see FIG. 10). With the proximal end part **461** of the plate piece **46** depressed downward, a distal end part of the plate piece **46** is displaced upward.

In addition, the plate piece **46** is provided in its distal end part with a second opening **462** penetrating the plate piece **46** in its thickness direction.

In the case **4A** configured as above, an engaging piece **25** of the puncture mechanism **2** is engaged with either of the small opening **451** and the second opening **462** according to the operating condition of the puncture mechanism **2**.

The operation of the puncture mechanism **2** in the body fluid sampling unit **1A** is as follows.

As shown in FIG. 8, when the support section **23** of the puncture mechanism **2** is in its initial position, a coil spring **24** has a natural length. In this instance, the engaging piece **25** has the lock part **251** located at the small opening **451** and in contact with (locked to) the distal end of the plate piece **46**. The locating of the support section **23** in a stand-by position

is thus maintained, i.e., the support section **23** is inhibited or prevented from unintended movement toward the proximal end side.

With an operating member **30** (support section **23**) pushed in the direction of the proximal end starting from the condition shown in FIG. 8, the lock part **251** of the engaging piece **25** moves over the portion between the distal end of the engaging piece **25** and the second opening **462**, against an elastic force of the engaging piece **25**. Thereafter, the lock part **251** enters into the second opening **462**, and is engaged with the second opening **462** as shown in FIG. 9.

The body part **231** of the support section **23** has its proximal end in abutment on the partition wall **41** in the same manner as in the first embodiment. By virtue of this, movement of the support section **23** in the direction of the proximal end is stopped.

In addition, the coil spring **24** is compressed in the same manner as in the first embodiment. As a result, a biasing force is accumulated in the coil spring **24**.

With the proximal end part **461** of the plate piece **46** depressed downward starting from the condition shown in FIG. 9, the second opening **462** is raised. This disengages the second opening **462** and the lock part **251** of the engaging piece **25** from each other. The compressed state of the coil spring **24** is thus cleared, and the coil spring **24** expands in the direction of the distal end. As a result, the support section **23** is displaced into a puncture position so that the needle point **211** protrudes from the distal end opening **421**. That is, puncture of a fingertip is enabled (see FIG. 10).

Thereafter, the coil spring **24** returns to the natural length so that the support section **23** is displaced into the initial position as illustrated in FIG. 11.

Thus, in the body fluid sampling unit **1A**, a disengaging section (the proximal end part **461** of the plate piece **46**) for disengaging the lock part **251** of the engaging piece **25** and the second opening **462** from each other is located at a proximal end part of the body fluid sampling unit **1A**. This helps ensure that the proximal end part **461** cannot be depressed downward until the tip **3** is mounted to a component measuring device **100** and released from a sampling implement containing section **43** and that accidental sticking can be advantageously inhibited or prevented from occurring at an unintended timing, such as at the time of mounting the tip **3** or at the time of detaching the operating member **30**.

In addition, the body fluid sampling unit **1A** may be entirely contained in a packaging material in a gas-tight manner. This makes it possible to maintain a sterile state of the needle **21** and the tip **3** or to maintain a dry state of the tip **3**.

FIGS. 12-16 illustrate a third embodiment of the body fluid sampling unit. The following description of the third embodiment primarily discusses aspects or features of this embodiment that differ from the embodiments described above. Features and aspects of the third embodiment that are the same as the earlier embodiments are designated by the same reference numeral and a detailed description of such features is not repeated.

This third embodiment is the same as the first embodiment above, except for the configurations of the case and the puncture mechanism.

The case **4B** of a body fluid sampling unit **1B** shown in FIGS. 12-16 includes a mechanism containing section **42A** composed of an outer tube, and a sampling implement containing section **43A** composed of an inner tube slid or positioned inside the mechanism containing section **42A** (outer tube) along its longitudinal direction.

The mechanism containing section **42A** is composed of a distal end part **425**, an intermediate part **426** and a proximal



end part **427** which differ in inside diameter. The inside diameter of the distal end part **425** is smaller than the inside diameter of the intermediate part **426**. In addition, the inside diameter of the intermediate part **426** is smaller than the inside diameter of the proximal end part **427**. Thus, the mechanism containing section **42A** increases in inside diameter in a stepwise manner in the direction of the proximal end.

The intermediate part **426** is provided with an opening **426a** that opens in (penetrates) an upper-side part of a tube wall of the intermediate part **426**. A cantilever-supported pushing piece **428** is formed at the opening **426a**. The proximal end of the pushing piece **428** is supported by a boundary part (stepped part) **426b** between the intermediate part **426** and the proximal end part **427**.

A portion of the pushing piece **428** in the vicinity of the boundary part **426b** is composed of a thin wall part **428a** having elasticity. This enables the pushing piece **428** to be easily depressed downward as shown in FIG. 15.

The proximal end part **427** includes a first opening (first engaging part) **427a** and a second opening (second engaging part) **427b** which both open in (penetrate) the upper-side parts of the tube wall thereof. The second opening **427b** is disposed on the distal end side of the first opening **427a**. In addition, the first opening **427a** and the second opening **427b** are each roughly rectangular in shape when viewed from the upper side. A pawl part **434** possessed by a sampling implement containing section **43A** is engaged with either of the first opening **427a** and the second opening **427b**, according to the operating condition of the puncture mechanism **2A**.

The sampling implement containing section **43A** is movably disposed at the proximal end part **427** of the mechanism containing section **42A**. The sampling implement containing section **43A** has a wall part **433** at the proximal end thereof, and, as a whole, has a bottomed tube shape.

A projected part **433a** is formed at the wall part **433** of the sampling implement containing section **43A** and projects in the direction of the distal end. The projected part **433a** is cylindrical in outer shape. A proximal end section of a coil spring **24** is fitted over the projected part **433a**.

The projected part **433a** is provided at its outer peripheral part with a plurality of pawl parts **433b** projecting in the outer radial direction. Each of the pawl parts **433b** is wedge-shaped so that its height gradually increases in the direction of the proximal end. Each of the pawl parts **433b** is in engagement with the proximal end section of the coil spring **24**. This prevents the projected part **433a** from being slipped from the proximal end section of the coil spring **24**, i.e., this makes it possible to support and fix the proximal end section of the coil spring **24**.

In addition, the sampling implement containing section **43A** is provided with a pawl part **434** at an outer peripheral part thereof. The pawl part **434** is wedge-shaped so that its height gradually increases in the direction of the proximal end. As has been above-mentioned, the pawl part **434** is engaged with either of the first opening **427a** and the second opening **427b**.

A support section **23A** of the puncture mechanism **2A** in this embodiment includes a cylindrically shaped body part **235** and a contact part **236** formed as a projection at the outer peripheral part of the body part **235**.

A proximal end part of the body part **235** is provided at its outer peripheral part with a pawl part **235a** projecting in the radial direction. The pawl part **235a** is wedge-shaped so that its height gradually increases in the direction of the distal end. The pawl part **235a** is in engagement with a distal end section of the coil spring **24**. This prevents the proximal end part of the body part **235** from being drawn off from the distal end

section of the coil spring **24**, i.e., this makes it possible to support and fix the distal end section of the coil spring **24**.

An engaging piece **25** is cantilever-supported at an intermediate part of the body part **235**.

The contact part **236** is provided at a lower part of the body part **235**, in the state of projecting downward. The contact part **236** is a portion which is block-like in shape.

In addition, a needle **21** is fitted (covered) with a cap **29** configured in substantially the same manner as the operating member **30** mentioned above. The cap **29** is detached from the needle **21** at the time of performing a puncturing operation.

The operation of the body fluid sampling unit **1B** configured as above is as follows. As shown in FIG. 13 (and in FIG. 12 also), when the body fluid sampling unit **1B** is in an unused state, the sampling implement containing section **43A** has its pawl part **434** in engagement with the first opening **427a** of the mechanism containing section **42A**.

In this situation, the support section **23A** in the puncture mechanism **2A** is in its initial position; namely, the coil spring **24** is in the state having its natural length. In addition, the engaging piece **25** has its lock part **251** in engagement with (in abutment on) a boundary part (stepped part) **425a** between the distal end part **425** and an intermediate part **426** of the case **4B**.

This prevents the needle **21** (support section **23A**) from unintended movement so that accidental sticking by a needle point **211** due to movement of the needle **21** can be relatively reliably prevented.

When a tip mounting section **103** of a component measuring device **100** is pushed from the proximal end side into the tip **3** in the condition shown in FIG. 13, the sampling implement containing section **43A** moves (slides) in the direction of the distal end relative to the mechanism containing section **42A**, together with the tip **3**. As a result, the pawl part **434** of the sampling implement containing section **43A** is disengaged from the first opening **427a** in the mechanism containing section **42A**, and the pawl part **434** becomes engaged with the second opening **427b** of the mechanism containing section **42A**. In addition, due to the engagement of the pawl part **434** with the second opening **427b**, movement of the sampling implement containing section **43A** relative to the mechanism containing section **42A** is stopped, i.e., the position of the sampling implement containing section **43A** relative to the mechanism containing section **42A** is fixed.

In addition, in the puncture mechanism **2A**, the mechanism containing section **42A** is brought closer to the support section **23A** so that the coil spring **24** is compressed between the mechanism containing section **42A** and the support section **23A**. As a result, a biasing force is accumulated in the coil spring **24**.

By such an operation starting from the initial position, the support section **23A** is displaced into a stand-by position, i.e., the puncture mechanism **2A** (body fluid sampling unit **1B**) is put into the condition shown in FIG. 14.

With the pushing piece **428** depressed downward starting from the condition shown in FIG. 14, the lock part **251** of the engaging piece **25** and the boundary part **425a** are disengaged from each other. In this instance, the compressed state of the coil spring **24** is cleared, and the coil spring **24** expands in the direction of the distal end. This displaces the support section **23A** into a puncture position so that the needle point **211** protrudes from a distal end opening **421** as shown in FIG. 15, i.e., puncture of a fingertip is enabled.

When the support section **23A** is located in the puncture position, a contact part **236** of the support section **23A** abuts

on the boundary part **425a**. This prevents the needle point **211** from excessively protruding through the distal end opening **421**.

Thereafter, the coil spring **24** returns to the condition of its natural length so that the support section **23A** is displaced into its initial position (as depicted in FIG. **16**).

After the position of the sampling implement containing section **43A** relative to the mechanism containing section **42A** is fixed, the tip **3** naturally is spaced away from the sampling implement containing section **43A**, together with a component measuring device **100**.

Thus, in the body fluid sampling unit **1B**, the puncture mechanism **2A** (support section **23A**) is displaced into a stand-by position (this operation will hereinafter be referred to as "charging operation") simultaneously (inclusive of substantially simultaneously) with the mounting operation of mounting the tip **3** to the component measuring device **100**. In other words, in the body fluid sampling unit **1B**, the mounting operation is utilized also as the charging operation.

This makes it unnecessary to perform the charging operation separately from the mounting operation as in the first embodiment. Therefore, operational aspects of the body fluid sampling unit **1B** in sampling blood is further enhanced.

FIGS. **17-21** illustrate a fourth embodiment of the body fluid sampling unit. The following description of the fourth embodiment primarily discusses aspects or features of this embodiment that differ from the embodiments described above. Features and aspects of the fourth embodiment that are the same as the earlier embodiments are designated by the same reference numeral and a detailed description of such features is not repeated.

This fourth embodiment is the same as the third embodiment above, except for the configurations of the case and the puncture mechanism. The case **4C** of the body fluid sampling unit **1C** shown in FIGS. **17-21** includes a mechanism containing section **42B** composed of an outer tube, and a sampling implement containing section **43B** composed of an inner tube slid or positioned inside the mechanism containing section **42B** (outer tube) along its longitudinal direction.

The mechanism containing section **42B** is changed (enlarged) in inside diameter at an intermediate part thereof, and is divided at the part of the change (boundary part or stepped part **429**) into a small diameter part (reduced diameter part) **47** and an enlarged diameter part **48** whose inside diameter is enlarged as compared with the small diameter part **47**.

The small diameter part **47** has a wall part **471** at the proximal end thereof and, as a whole, has a bottomed tube shape.

The enlarged diameter part **48** has a first opening (first engaging part) **481** and a second opening (second engaging part) **482** which open in (penetrate) upper-side parts of the tube wall thereof. The second opening **482** is disposed on the proximal end side of the first opening **481**.

The first opening **481** and the second opening **482** are roughly rectangular in shape as viewed from the upper side. In addition, the second opening **482** is larger (longer) than the first opening **481** in size in the longitudinal direction of the enlarged diameter part **48**.

A pawl part **434** possessed by a sampling implement containing section **43B** is engaged with either of the first opening **481** or the second opening **482** according to the operating condition of a puncture mechanism **2B**.

The sampling implement containing section **43B** having a bottomed tube shape is movably disposed in the enlarged diameter part **48** of the mechanism containing section **42B**.

The sampling implement containing section **43B** has a guide part **436** provided on the proximal end side of a wall

part **433**, with a clearance **435** between the guide part **436** and the wall part **433**. The guide part **436** is plate-shaped (inclusive of plate-like shaped), and is disposed parallel (inclusive of substantially parallel) to the wall part **433**.

In addition, the wall part **433** and the guide part **436** are provided respectively with through-holes **433c**, **436a** that pierce or penetrate the wall part **433** and the guide part **436** respectively. The through-holes **433c**, **436a** are disposed coaxially with each other. The through-hole **436a** is larger than the through-hole **433c**.

The puncture mechanism **2B** contained in the mechanism containing section **42B** includes a support section **23B**, a first coil spring **26**, a second coil spring **27**, and an operating member (pushing member) **28**.

The support section **23B** is cylindrical in outer shape. When the body fluid sampling unit **1C** is in an unused state, a distal end part of the support section **23B** is fitted (is in frictional engagement with) the through-hole **433c** in the wall part **433** of the sampling implement containing section **43B** as seen in FIGS. **18** and **19**.

In addition, the support section **23B** has a hollow part **237** opening in the vertical directions. The hollow part **237** is provided at its distal end part with an inclined surface **237a** inclined relative to the longitudinal direction of the hollow part **237**. The second coil spring **27** and the operating member **28** are disposed in the hollow part **237**.

A proximal end part of the second coil spring **27** is supported on and is fixed to a proximal end part of the hollow part **237** (support section **23B**). The distal end of the second coil spring **27** is a free end (i.e., not in engagement with another part) when the body fluid sampling unit **1C** is in the unused state.

The operating member **28** is disposed to be vertically movable inside the clearance **435** in the sampling implement containing section **43B** along the guide part **436** (wall part **433**). In addition, the operating member **28** penetrates the hollow part **237** in the support section **23B**.

The operating member **28** possesses a quadrangular prism shape. The operating member **28** is provided at a lower part thereof with an inclined surface **281** opposed to the inclined surface **237a** of the support section **23B**. In addition, an upper part **282** of the operating member **28** protrudes through the second opening **482**.

The first coil spring **26** has its proximal end supported on and fixed to the wall part **471** of the small diameter part **47**. The distal end of the first coil spring **26** is in abutment on a projection (not shown) provided at a proximal end part of the support section **23B** when the body fluid sampling unit **1C** is in the unused state.

The operation of the body fluid sampling unit **1C** configured as above is as follows.

As shown in FIG. **18** (and in FIG. **17** also), when the body fluid sampling unit **1C** is in the unused state, the pawl part **434** of the sampling implement containing section **43B** is in engagement with the first opening **481** of the mechanism containing section **42B**.

In this instance, in the puncture mechanism **2B**, the support section **23B** is in its initial position, i.e., the first coil spring **26** and the second coil spring **27** are in the condition having their natural lengths. In addition, a distal end part of the support section **23B** is fitted in the through-hole **433c** of the sampling implement containing section **43B**, and the inclined surface **281** of the operating member **28** is in contact with the inclined surface **237a** of the support section **23B**.

When a tip mounting section **103** of a component measuring device **100** is pushed from the distal end side into the tip **3** in the condition shown in FIG. **18**, the sampling implement

## 21

containing section 43B is moved (slid) in the direction of the proximal end relative to the mechanism containing section 42B, together with the tip 3. This disengages the pawl part 434 of the sampling implement containing section 43B from the first opening 481 of the mechanism containing section 42B, and the pawl part 434 is engaged with the second opening 482 of the mechanism containing section 42B. In addition, due to the engagement of the pawl part 434 with the second opening 482, the position of the sampling implement containing section 43B relative to the mechanism containing section 42B is fixed.

In the puncture mechanism 2B, the support section 23B is moved in the direction of the proximal end, together with the sampling implement containing section 43B. This brings the support section 23B and the wall part 471 of the mechanism containing section 42B closer to each other, so that the first coil spring 26 is compressed between them. As a result, a biasing force is accumulated in the first coil spring 26.

In addition, the operating member 28 also is moved in the direction of the proximal end, together with the sampling implement containing section 43B (support section 23B). By this movement, the upper part 282 of the operating member 28 is moved inside the second opening 482 in its longitudinal direction.

By such an operation from the initial position, the support section 23B is displaced into a stand-by position, i.e., the puncture mechanism 2B (body fluid sampling unit 1C) is put into the condition shown in FIG. 19.

With the operating member 28 depressed downward starting from the condition shown in FIG. 19, the inclined surface 281 of the operating member 28 pushes the inclined surface 237a of the support section 23B in the direction of the distal end. By virtue of this, the frictional engagement between the support section 23B and the through-hole 433c of the sampling implement containing section 43B is released. In this instance, the compressed state of the first coil spring 26 is cleared, and the first coil spring 26 expands in the direction of the distal end. As a result, the support section 23B is displaced into a puncture position, and puncture of a fingertip is enabled (see FIG. 20).

In addition, associated with the displacement of the support section 23B to the puncture position, the second coil spring 27 is also moved in the direction of the distal end. As the second coil spring 27 thus moves, the distal end abuts on the operating member 28, whereby the second coil spring 27 is further compressed between the operating member 28 and a proximal end part of the hollow part 237. The second coil spring 27 thus compressed in this way tends to return to its natural length. This displaces the support section 23B from the puncture position to the initial position as seen in FIG. 21.

Thus, in the body fluid sampling unit 1C, the charging operation can be performed simultaneously (inclusive of substantially simultaneously) with the mounting operation of mounting the tip 3 to a component measuring device 100. This makes it unnecessary to perform the charging operation separately from the mounting operation as in the first embodiment. Therefore, operational aspects of the body fluid sampling unit 1C in sampling blood is enhanced. In addition, cleanliness of a needle point 211 is maintained to an extent comparable to the cleanliness of the tip 3 so that a needle point protective member can be omitted if desired, and an operation of removing such a protective member can be advantageously omitted.

This illustrated embodiment of the body fluid sampling unit 1C has two coil springs, i.e., the first coil spring 26 for displacing the support section 23B to the puncture position (protruding a needle 21) and the second coil spring 27 for

## 22

returning the support section 23B to the initial position. However, this embodiment is not limited in this regard. For example, a configuration may be adopted in which the support section 23B is displaced to each position by a single coil spring.

FIG. 22 is a perspective view showing a fifth embodiment of the body fluid sampling unit according to the present invention. The following description of the fifth embodiment primarily discusses aspects or features of this embodiment that differ from the embodiments described above. Features and aspects of the fifth embodiment that are the same as the earlier embodiments are designated by the same reference numeral and a detailed description of such features is not repeated.

This embodiment is the same as the first embodiment above, except for the configuration of the tip. The case 4D of the body fluid sampling unit 1D shown in FIG. 22 includes the sampling implement containing section 43D which is provided or located at an outer peripheral section (side section) of the case 4D. The sampling implement containing section 43D has a concave portion obtained by concaving an outer peripheral section of the case 4D.

A tip 3A is contained in the sampling implement containing section 43. The tip 3A includes a tip body 31A having a hollow plate-like shape, and a sensor section 34 contained (disposed) in the tip body 31A as a detecting section for detecting the quantity of glucose in blood.

A surface on one side of the tip body 31A is provided with an opening 313 communicating with the inside of the tip body 31A. The opening 313 is a portion which functions as an introducing section for introducing blood into the sensor section 34.

The sensor section 34 includes a pair of electrodes 341, and a reagent coated part or reagent carrying part 342 coated with a reagent.

The two electrodes 341 are provided, with a spacing therebetween, by coating or printing in the tip body 31A. The electrodes 341 are electrically connected to a component measuring device 100 (not shown) in the condition where the tip 3A is mounted to the component measuring device 100.

The reagent coated part 342 is so provided as to make contact with the two electrodes 341 and include an area of the electrodes 341. In the condition where the tip 3A is mounted to the component measuring device, the reagent coated part 342 (reagent) reacts with glucose in the blood flowed in through the opening 313, generating a current between the two electrodes 341. The quantity of glucose in the blood can be detected according to the current.

The reagent contained in the reagent coated part 342 is not particularly limited. For example, an appropriate combination of a glucose oxidase, which is an oxidoreductase, with an electron acceptor such as potassium ferricyanide and ferrocene derivatives is used. Incidentally, while the two electrodes 341 function as a working electrode and a counter electrode, a three-electrode system may be adopted which includes a third electrode as a reference electrode in addition to the two electrodes.

The body fluid sampling unit described above is intended to be discarded after mounting the body fluid sampling implement to the component measuring device, performing puncture of a living body surface and measuring a predetermined component in the body fluid let flow out. Namely, the body fluid sampling unit is discarded after being used one time. In view of this, the body fluid sampling unit inclusive of the puncture mechanism is configured to be simple in structure.

While the embodiments of the body fluid sampling unit shown in the drawings have been described above, the invention is not limited to these specific embodiments. The com-

23

ponent parts of the body fluid sampling unit can be replaced by those of arbitrary configurations which function in a manner that is the same, similar or equivalent to the functional attributes of the component parts in the embodiments described above. Additional components or structures may be added to the different embodiments.

In addition, the body fluid sampling unit may be a combination of two or more configurations (features) of the above embodiments.

For example, the detecting section in the second to fourth embodiments is not limited to the one composed of the test paper but may be composed of a sensor section in the same manner as in the fifth embodiment.

Also, each of the body fluid sampling units in the first embodiment and the third to fifth embodiments may be contained in a packaging material, in the same manner as in the body fluid sampling unit in the second embodiment.

The principles, embodiments and modes of operation have been described in the foregoing specification, but the invention which is intended to be protected is not to be construed as limited to the particular embodiments disclosed. The embodiments described herein are to be regarded as illustrative rather than restrictive. Variations and changes may be made by others, and equivalents employed, without departing from the spirit of the present invention. Accordingly, it is expressly intended that all such variations, changes and equivalents which fall within the spirit and scope of the present invention as defined in the claims, be embraced thereby.

What is claimed is:

1. A body fluid sampling unit comprising:

a puncture mechanism comprising a needle possessing a sharp needle point at a distal end of the needle, and drive means for operating the needle to puncture a living body surface with the needle point;

a body fluid sampling implement comprising an introducing section for introducing a body fluid flowing out from a puncture portion of the living body surface punctured with the needle point, a detecting section for detecting a predetermined component in the body fluid introduced through the introducing section, and a mounted section configured to be mounted to a component measuring device for measuring at least one of a quantity and a property of the predetermined component detected by the detecting section;

a container comprising a mechanism containing section containing the puncture mechanism so that the needle point of the puncture mechanism is movable by the drive means, and a sampling implement containing section containing the body fluid sampling implement in a manner allowing the body fluid sampling implement to be removed from the sampling implement containing section; and

the puncture mechanism is put into a state of being prepared to perform an operation of puncturing the living body surface by removal of the body fluid sampling implement from the sampling implement containing section.

2. The body fluid sampling unit according to claim 1, wherein the drive mean comprises a support section positioned inside the mechanism containing section and an engaging piece forming a part of the support section and engaging an inner periphery of an opening in the container, the needle possessing a proximal end fitted in the support section so that the needle and the support section move together.

24

3. The body fluid sampling unit according to claim 2, wherein the drive means comprises a spring which contacts the support section and applies a biasing force to the support section.

4. The body fluid sampling unit according to claim 2, further comprising a plate piece comprising a proximal end portion possessing an inner periphery contacted by an outer periphery of the body fluid sampling implement, the plate piece also comprising a distal end portion at which is located the opening.

5. The body fluid sampling unit according to claim 4, wherein plate piece is supported by a wall positioned intermediate the proximal end portion and the distal end portion so that a force applied in one direction to the proximal end portion of the plate piece causes movement of the distal end portion of the plate piece in an opposite direction, the contact between the outer periphery of the body fluid sampling implement and the inner periphery of the proximal end portion of the plate piece preventing the distal end portion of the plate piece from moving in a manner causing the engaging piece to become disengaged from the opening when a force is applied to the proximal end portion of the plate piece.

6. The body fluid sampling unit according to claim 1, further comprising an operating member, the operating member including a needle containing section in which the sharp needle point is positioned so that the operating member covers the sharp needle point of the needle.

7. A body fluid sampling unit comprising:

a case on which is supported a movable plate piece;

a needle positioned inside the case, the needle possessing a sharp needle point at a distal end of the needle for puncturing living body tissue to obtain body fluid;

a body fluid sampling implement configured to be mounted on a component measuring device which is adapted to measure at least one of a quantity and a property of a predetermined component of a sample of the body fluid obtained by the puncturing of the living body tissue, the body fluid sampling implement comprising a reagent containing part that includes a reagent adapted to interact with the predetermined component of the sample of the body fluid;

a spring positioned to apply a biasing force to the needle urging the needle from a housed position in which the sharp needle point is housed inside the case to a puncturing position in which the sharp needle point is exposed outside the case to puncture the living body tissue;

an engaging piece connected to the needle, the engaging piece being shiftable from an engaged position in which the engaging piece engages the plate piece so that the needle remains in the housed position and the biasing force applied to the needle does not move the needle toward the puncturing position to a released position in which the engaging piece moves out of engagement with the plate piece so that the biasing force applied to the needle moves the needle toward the puncturing position, the engaging piece being movable from the engaged position to the released position in response to movement of the plate piece;

the body fluid sampling implement being positioned in the case in contact with the plate piece so that the contact between the plate piece and the body fluid sampling implement prevents a force applied to the plate piece from resulting in the movement of the plate piece which causes the engaging piece to shift from the engaged position to the released position; and

25

the body fluid sampling implement being removable from the case so that the biasing force applied to the plate piece results in the movement of the plate piece which causes the engaging piece to shift from the engaged position to the released position to permit the needle to move toward the puncturing position under the biasing force of the spring.

8. The body fluid sampling unit according to claim 7, wherein the body fluid sampling implement comprises a tip body possessing a recessed portion which receives a portion of the component measuring device when the body fluid sampling implement is mounted on the component measuring device.

9. The body fluid sampling unit according to claim 8, wherein the body fluid sampling implement comprises an introducing section extending from the tip body, the introducing section including a through passage communicating a distal end of the introducing section with the recessed portion so that the sample of the body fluid is flowable from the distal end of the introducing section to the recessed portion.

10. The body fluid sampling unit according to claim 9, wherein the reagent containing part that includes the reagent adapted to interact with the predetermined component of the sample of the body fluid is a test paper in the recessed portion of the body fluid sampling implement.

11. The body fluid sampling unit according to claim 7, wherein the needle possesses a proximal end mounted in a supporting section so that the needle is supported in the supporting section, wherein the engaging piece is connected to the supporting section.

12. The body fluid sampling unit according to claim 7, wherein the plate piece overlies an opening in the case, the plate piece being smaller in size than the opening so that a distal portion of the opening in the case is uncovered by the plate, the plate piece being supported on the case by a partition wall, the partition wall being connected to the plate piece at an intermediate portion of the plate piece between distal and proximal ends of the plate piece so that when the force applied to the plate piece is a downward force applied to the proximal end of the plate piece, the distal end of the plate piece moves upwardly in an opposite direction.

13. The body fluid sampling unit according to claim 7, wherein the engaging piece, when in the engaged position, engages a hole in the plate piece.

14. The body fluid sampling unit according to claim 13, wherein the hole engaged by the engaging piece in the engaged position is a through hole in the plate piece.

15. A body fluid sampling unit comprising:

a case possessing an interior and an opening at a distal end of the case;

a needle positioned in the interior of the case, the needle possessing a sharp needle point at a distal end of the needle for puncturing living body tissue to obtain body fluid;

a body fluid sampling implement configured to be mounted on a component measuring device which is adapted to measure at least one of a quantity and a property of a predetermined component of a sample of the body fluid obtained by the puncturing of the living body tissue, the

26

body fluid sampling implement comprising a test paper containing a reagent adapted to interact with the predetermined component of the sample of the body fluid;

a spring applying a biasing force to the needle urging the needle from a housed position in which the sharp needle point is housed in the interior of the case to a puncturing position in which the sharp needle point extends distally beyond the opening at the distal end of the case;

the body fluid sampling implement being positioned in the case in contact with a portion of the case and being removable from the case so that the body fluid sampling implement is not in contact with the portion of the case; the needle being prevented from moving to the puncturing position from the housed position under the biasing force of the spring whenever the body fluid sampling implement is positioned in the case in contact with a portion of the case; and

the needle being permitted to move from the housed position to the puncturing position under the biasing force of the spring when the body fluid sampling implement is removed from the case so that the body fluid sampling implement is not in contact with the portion of the case.

16. The body fluid sampling unit according to claim 15, wherein the needle is connected to, and movable together as a unit with, an engaging piece which engages a part of the case, the engaging piece being prevented from moving out of engagement with the part of the case whenever the body fluid sampling implement is positioned in the case in contact with the portion of the case, the engaging piece being movable out of engagement with the part of the case when the body fluid sampling implement is removed from the case so that the body fluid sampling implement is not in contact with the portion of the case.

17. The body fluid sampling unit according to claim 16, wherein the part of the case engaged by the engaging piece is a hole.

18. The body fluid sampling unit according to claim 16, wherein the part of the case engaged by the engaging piece is a part of a plate piece supported on the case by a partition wall, the partition wall being connected to the plate piece at an intermediate portion of the plate piece between distal and proximal end portions of the plate piece so that a downward force applied to the proximal end portion of the plate piece causes the distal end portion of the plate piece to move upwardly in an opposite direction.

19. The body fluid sampling unit according to claim 18, wherein the part of the case engaged by the engaging piece is a hole in the distal end portion of the plate piece, the downward force applied to the proximal end portion of the plate piece causing the distal end portion of the plate piece to move and release engagement between the engaging piece and the hole in the distal end portion of the plate piece.

20. The body fluid sampling unit according to claim 16, wherein the needle possesses a proximal end portion supported in a supporting section, the engaging piece being connected to the supporting section, and the supporting section being positioned in the interior of the case and acted on by the spring.

\* \* \* \* \*