



US 20200119080A1

(19) **United States**

(12) **Patent Application Publication**  
**CAO et al.**

(10) **Pub. No.: US 2020/0119080 A1**

(43) **Pub. Date: Apr. 16, 2020**

(54) **METHODS OF MAKING SEMICONDUCTOR X-RAY DETECTOR**

*A61B 6/03* (2006.01)

*G01T 3/08* (2006.01)

*G01T 1/17* (2006.01)

(71) Applicant: **SHENZHEN XPECTVISION TECHNOLOGY CO., LTD.**, Shenzhen (CN)

(52) **U.S. Cl.**

CPC .. *H01L 27/14658* (2013.01); *H01L 27/14661*

(2013.01); *H04N 5/32* (2013.01); *H01L*

*27/14689* (2013.01); *H01L 27/14678*

(2013.01); *G01T 1/2964* (2013.01); *G01T*

*1/247* (2013.01); *G01T 1/246* (2013.01); *G01T*

*1/2018* (2013.01); *A61B 6/032* (2013.01);

*G01T 1/244* (2013.01); *G01T 1/24* (2013.01);

*G01T 3/08* (2013.01); *G01T 1/17* (2013.01);

*H04N 5/367* (2013.01)

(72) Inventors: **Peiyan CAO**, Shenzhen (CN);  
**Chongshen SONG**, Shenzhen (CN);  
**Yurun LIU**, Shenzhen (CN)

(21) Appl. No.: **16/709,723**

(22) Filed: **Dec. 10, 2019**

**Related U.S. Application Data**

(63) Continuation of application No. 16/185,370, filed on Nov. 9, 2018, now Pat. No. 10,535,703, which is a continuation of application No. PCT/CN2017/072184, filed on Jan. 23, 2017.

**Publication Classification**

(51) **Int. Cl.**

*H01L 27/146* (2006.01)

*H04N 5/367* (2006.01)

*H04N 5/32* (2006.01)

*G01T 1/29* (2006.01)

*G01T 1/24* (2006.01)

*G01T 1/20* (2006.01)

(57)

**ABSTRACT**

Disclosed herein is an image sensor and a method of making the image sensor. The image sensor may comprise one or more packages of semiconductor radiation detectors. Each of the one or more packages may comprise a radiation detector that comprises a radiation absorption layer on a first strip of semiconductor wafer and an electronics layer on a second strip of semiconductor wafer. The radiation absorption layer may be continuous along the first strip of semiconductor wafer with no coverage gap. The first strip and the second strip may be longitudinally aligned and bonded together. The radiation detector may be mounted on a printed circuit board (PCB) and electrically connected to the PCB close to an edge of the radiation detector.

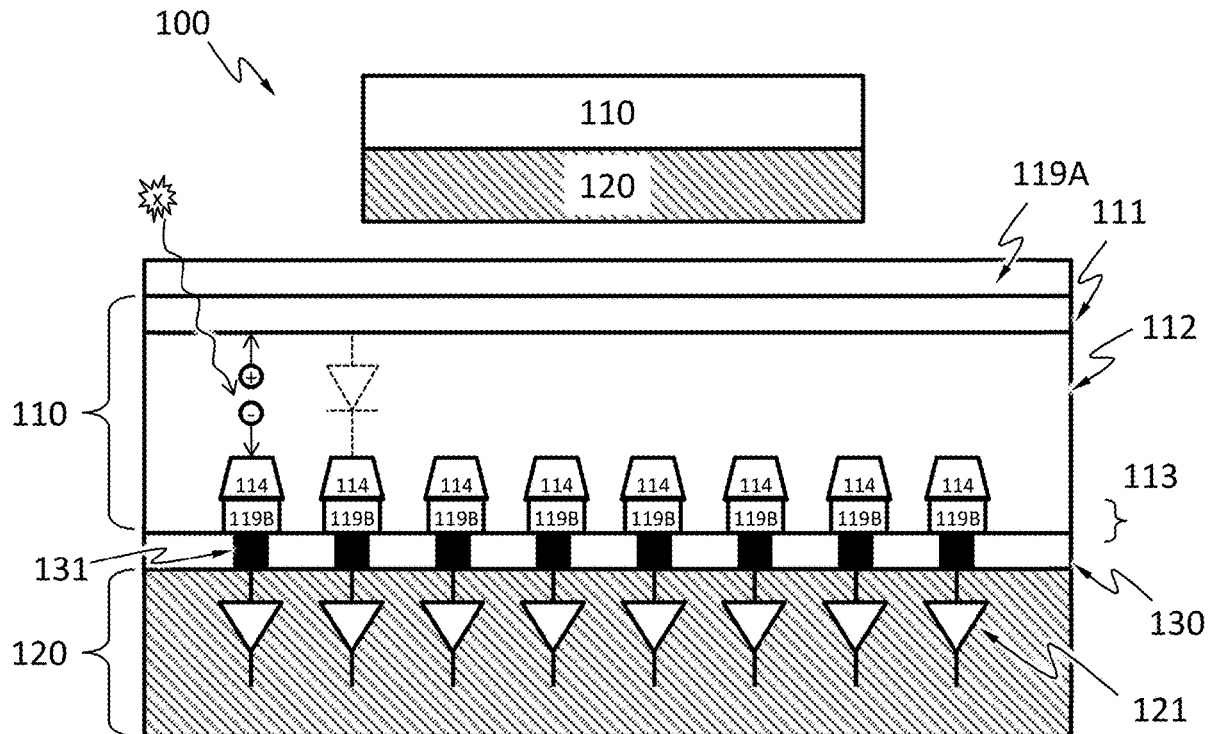

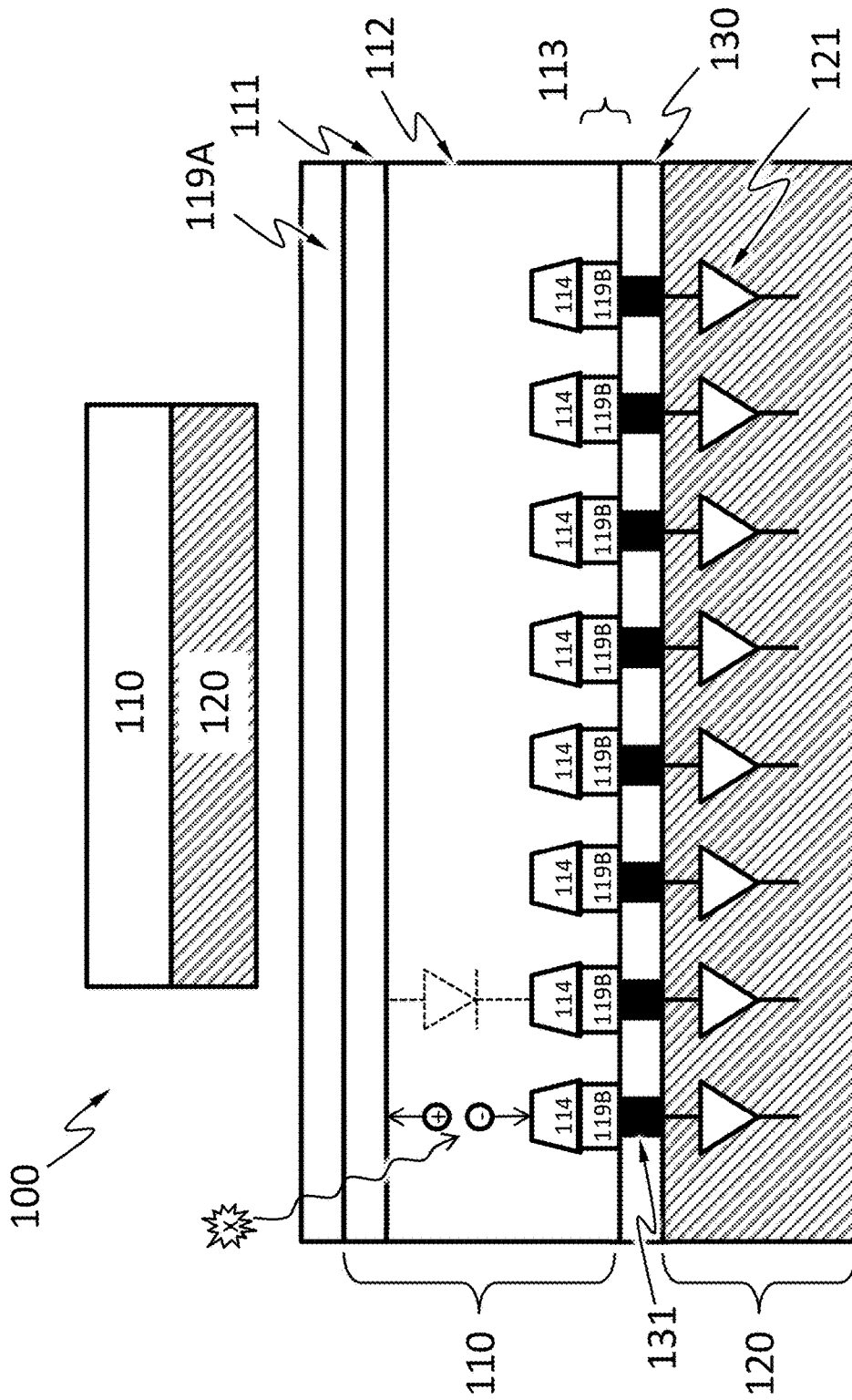

Fig. 1A

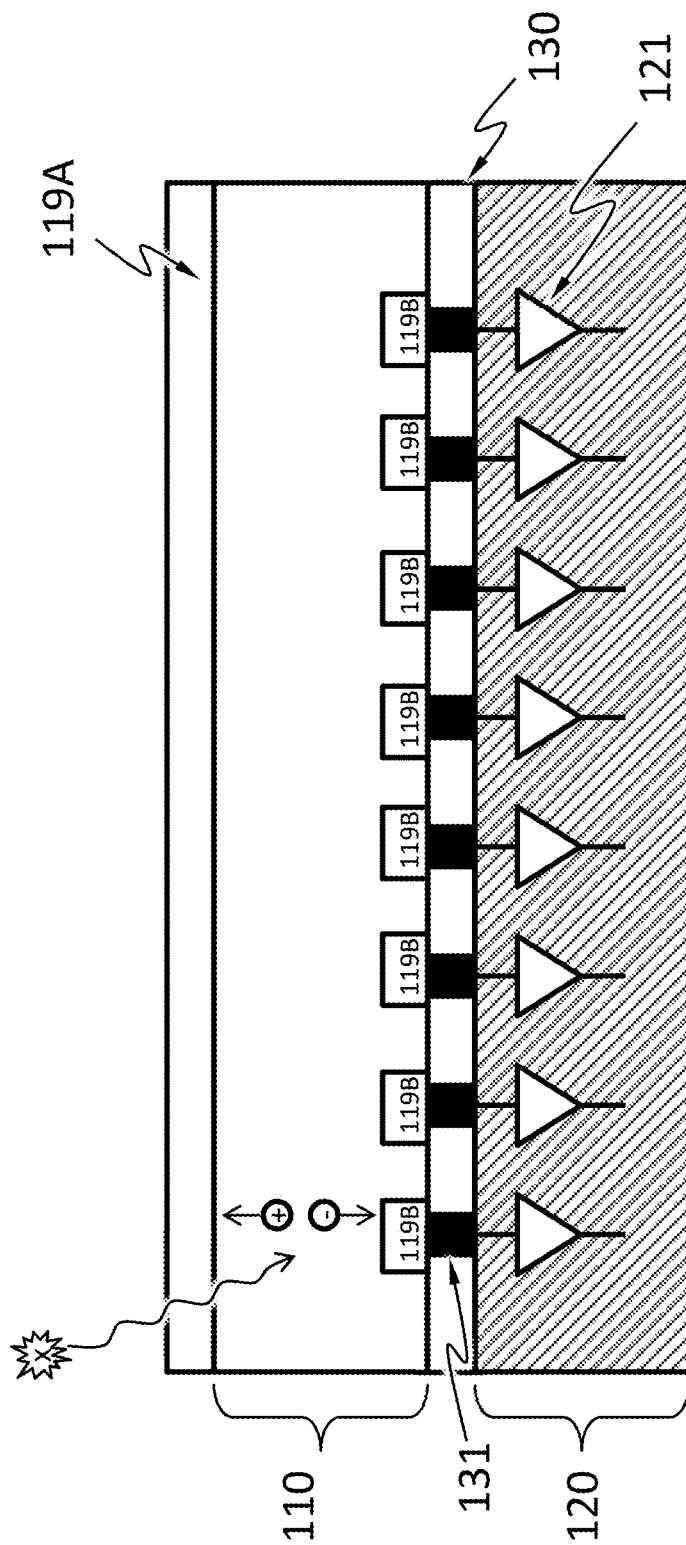

Fig. 1B

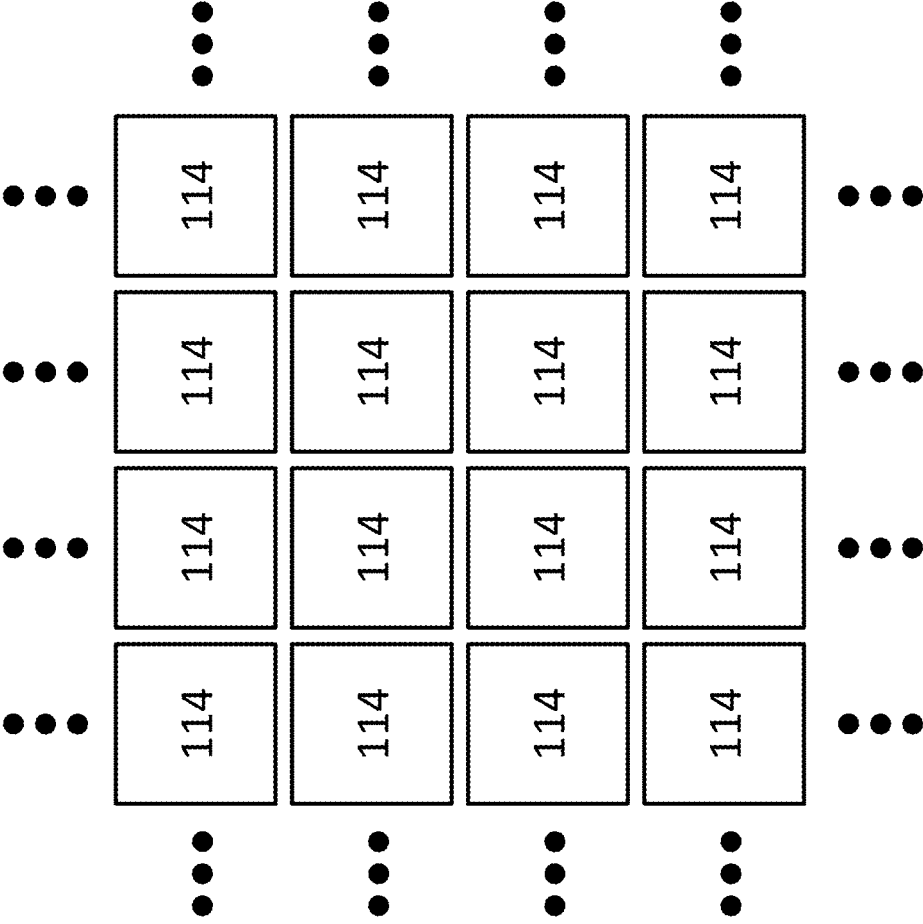

Fig. 2

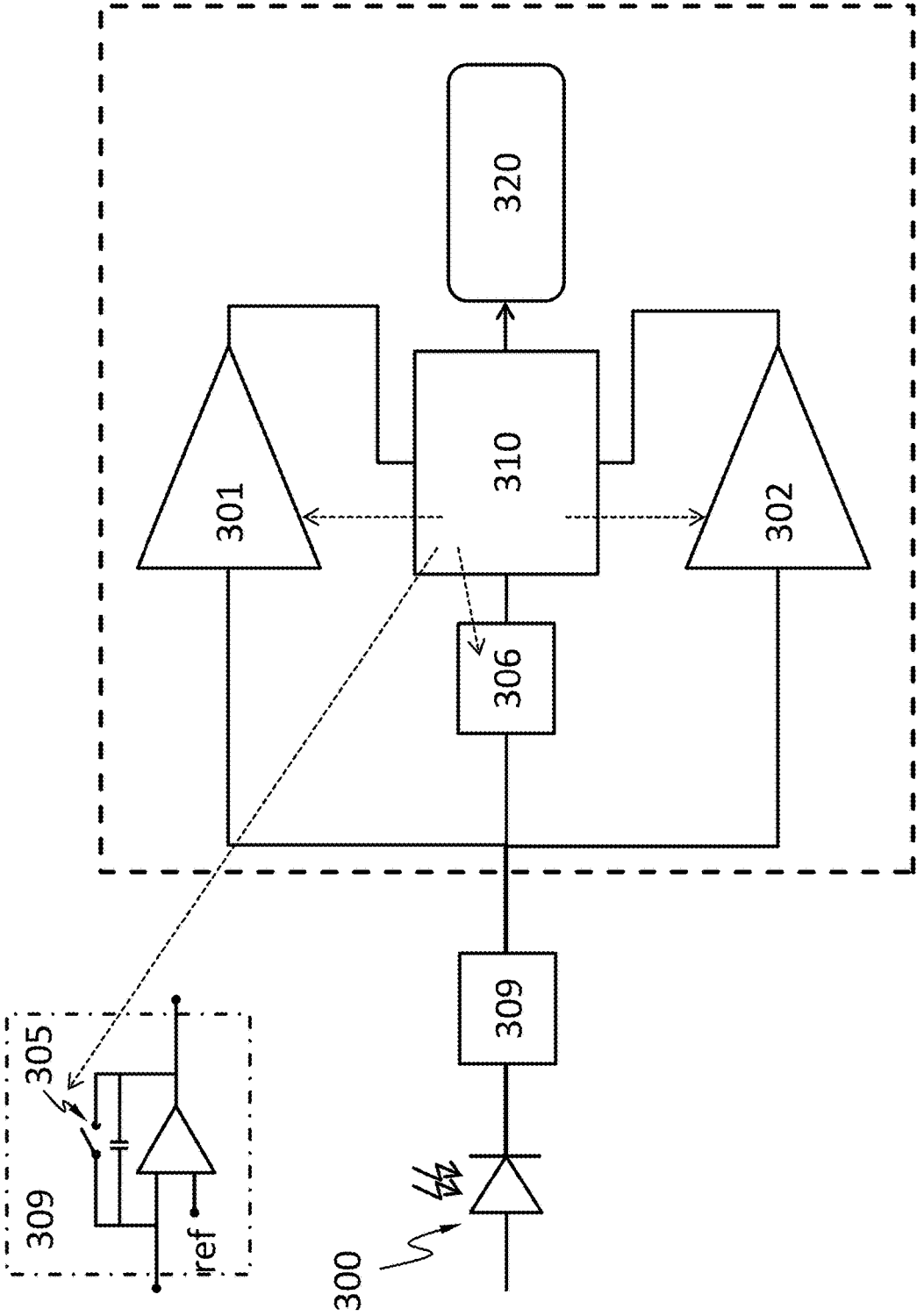

Fig. 3A

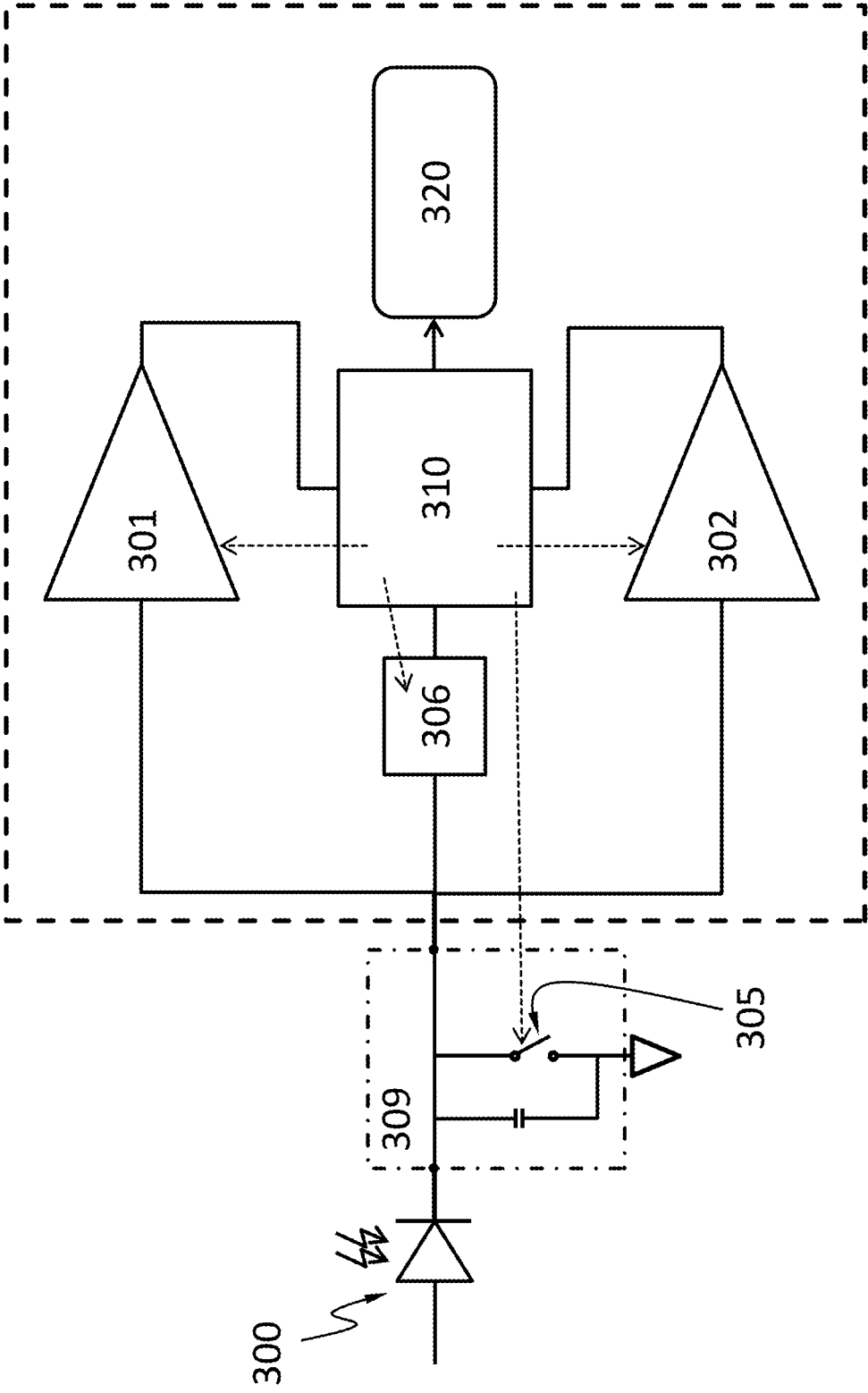

Fig. 3B

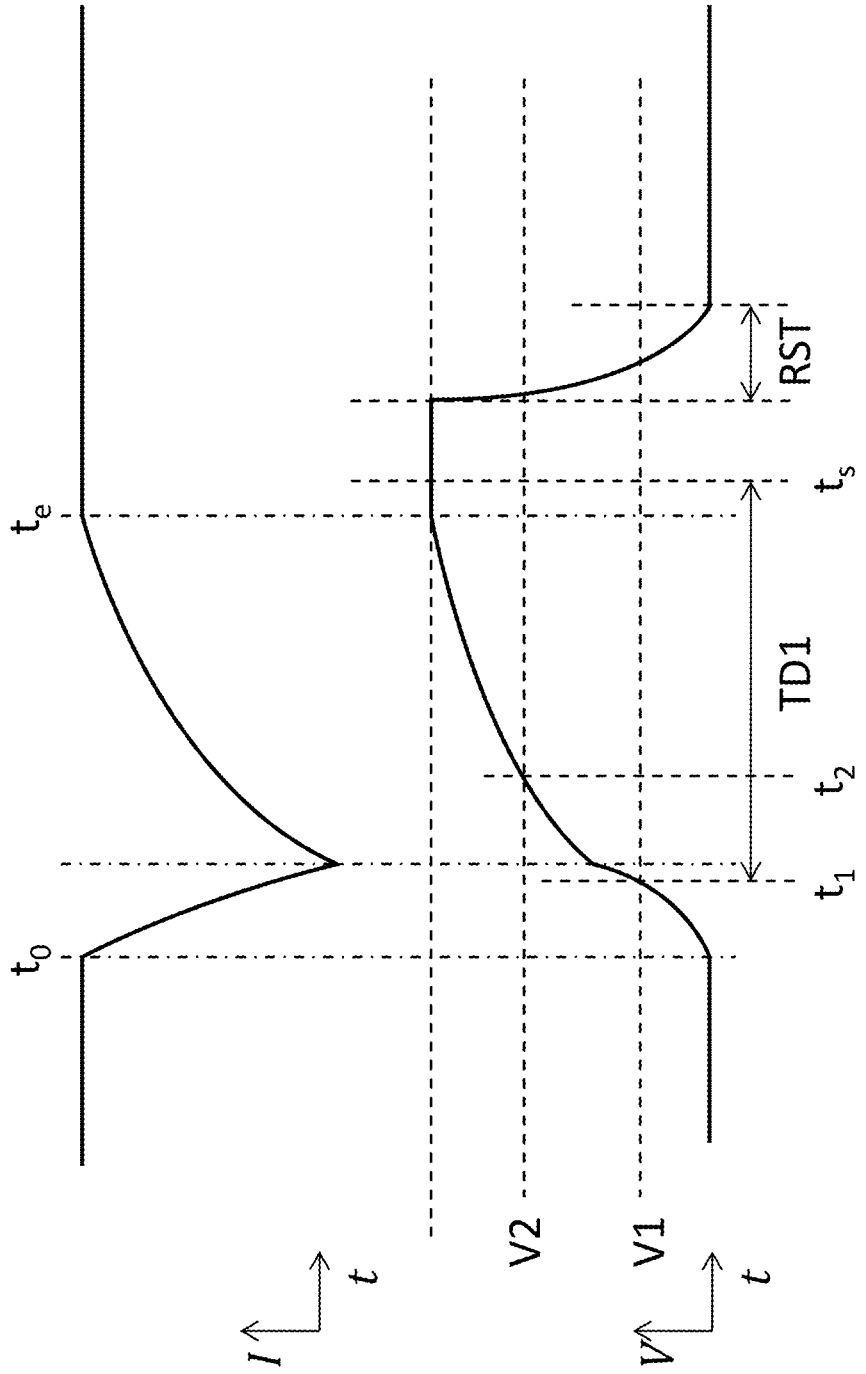

Fig. 4

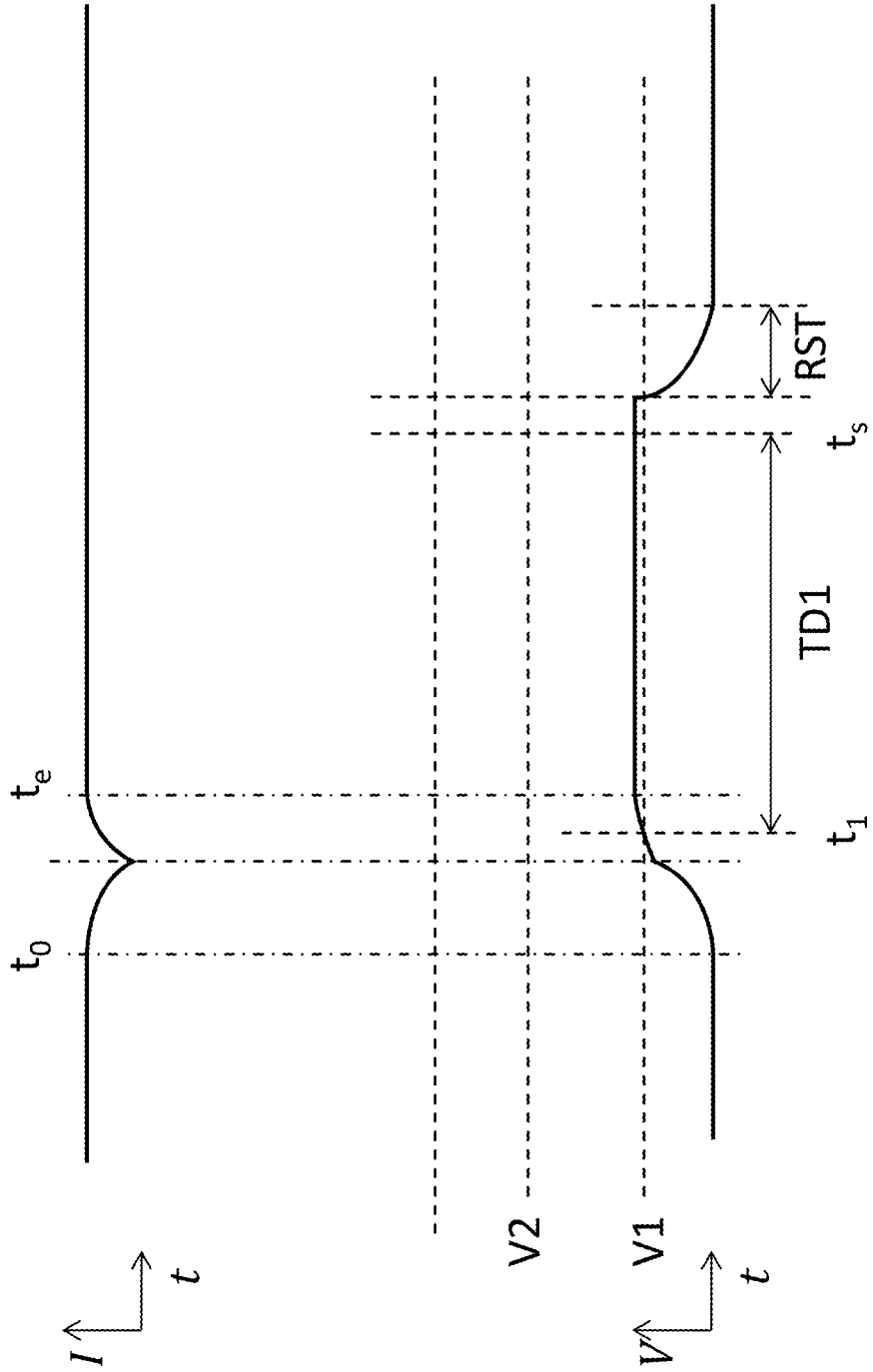

Fig. 5



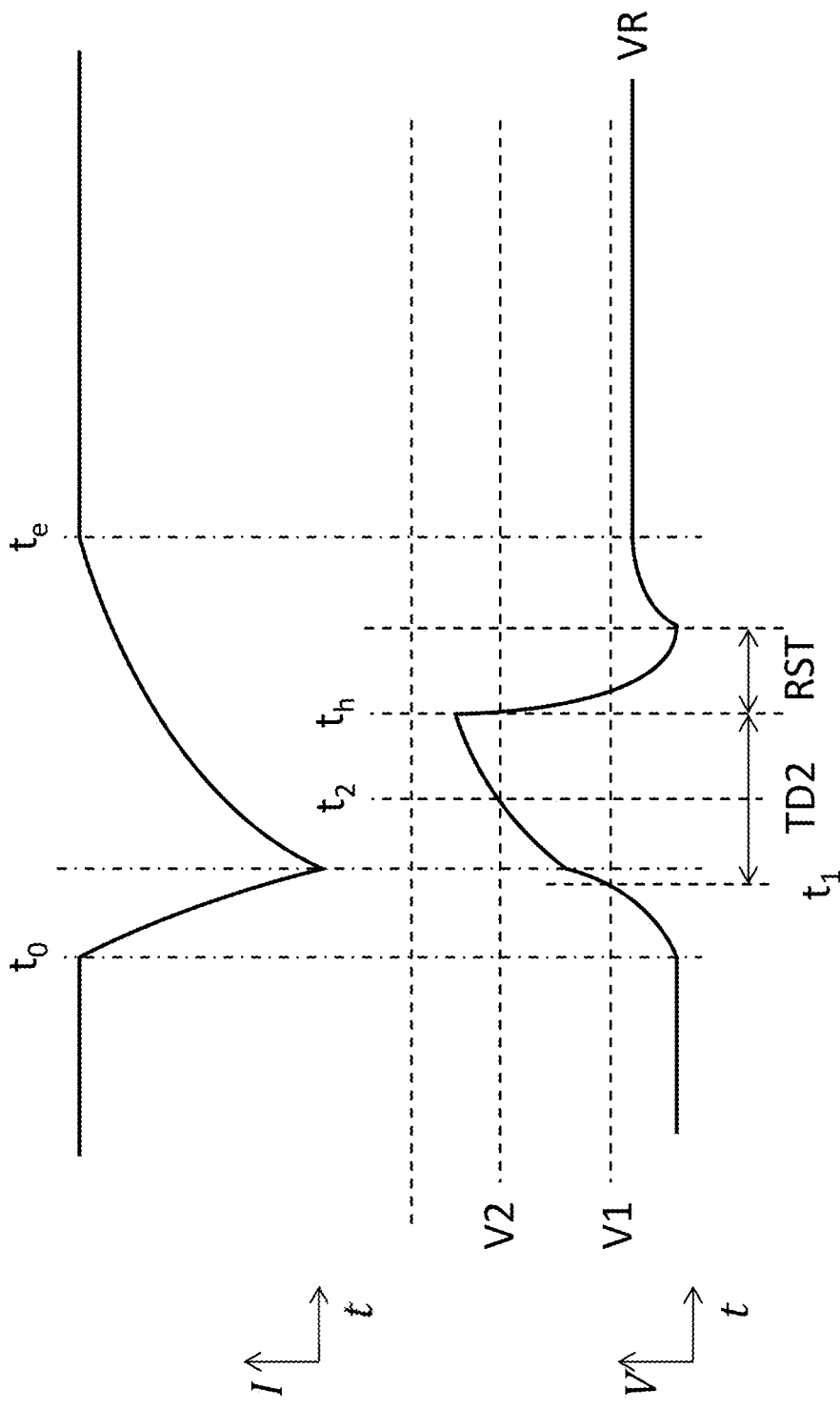

Fig. 6

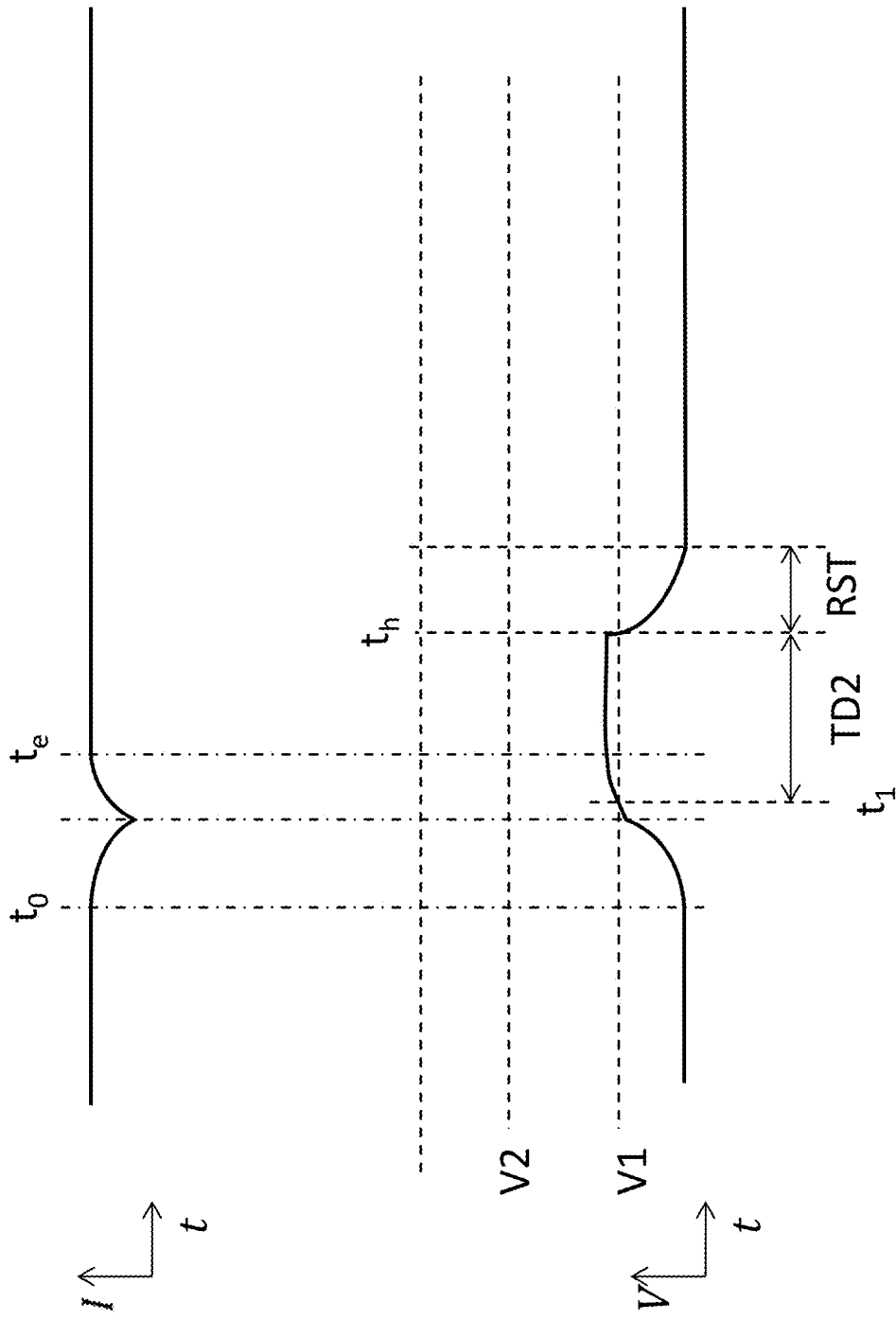

Fig. 7

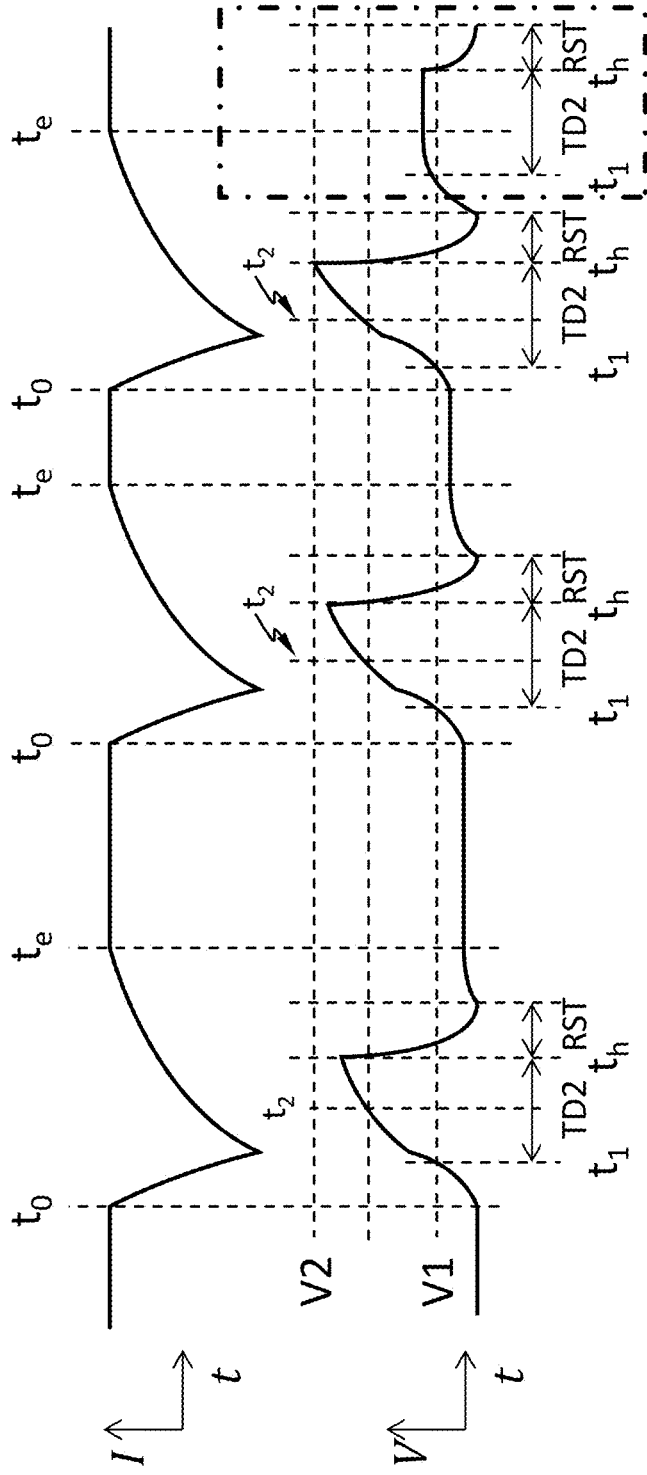

Fig. 8

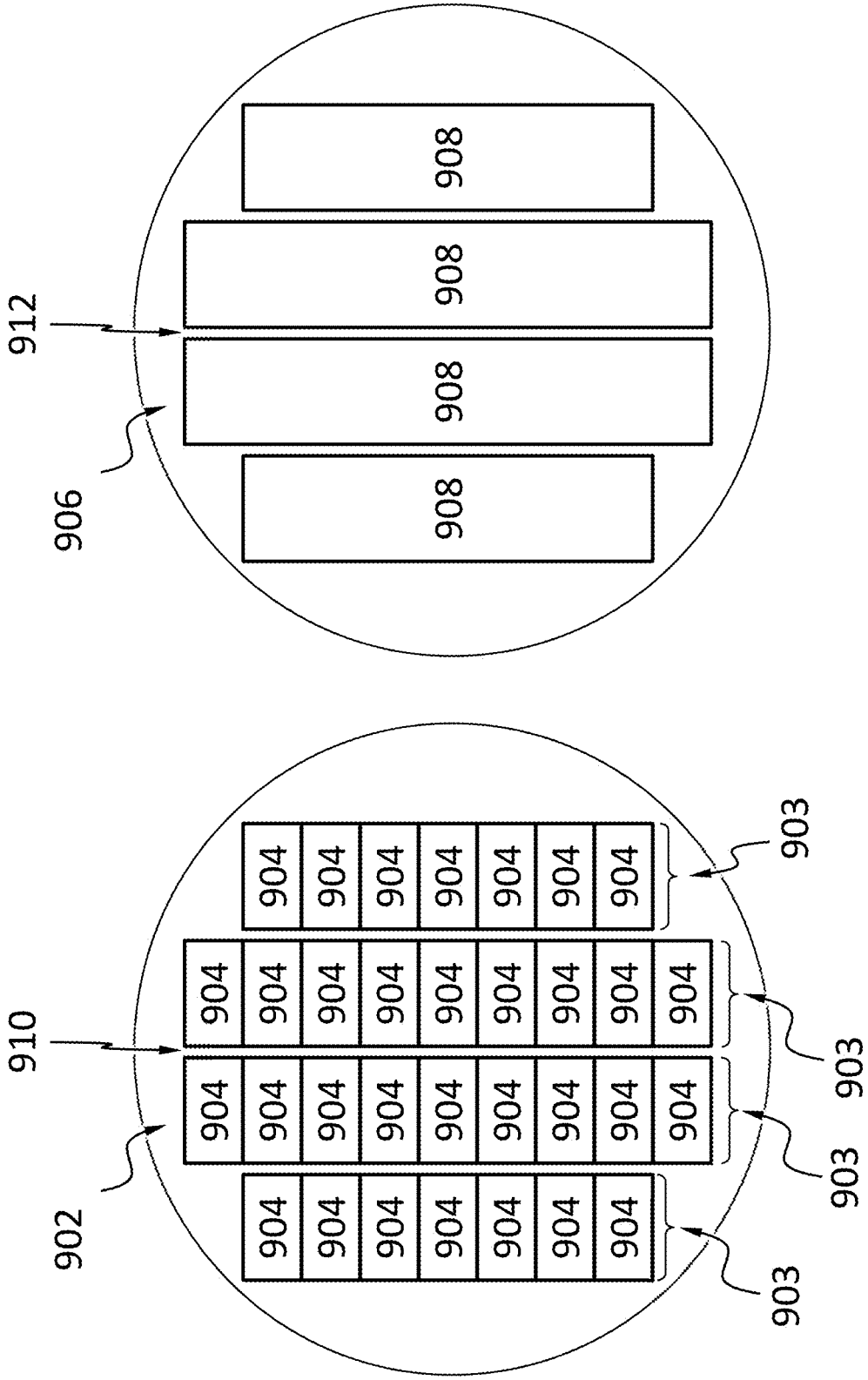

Fig. 9

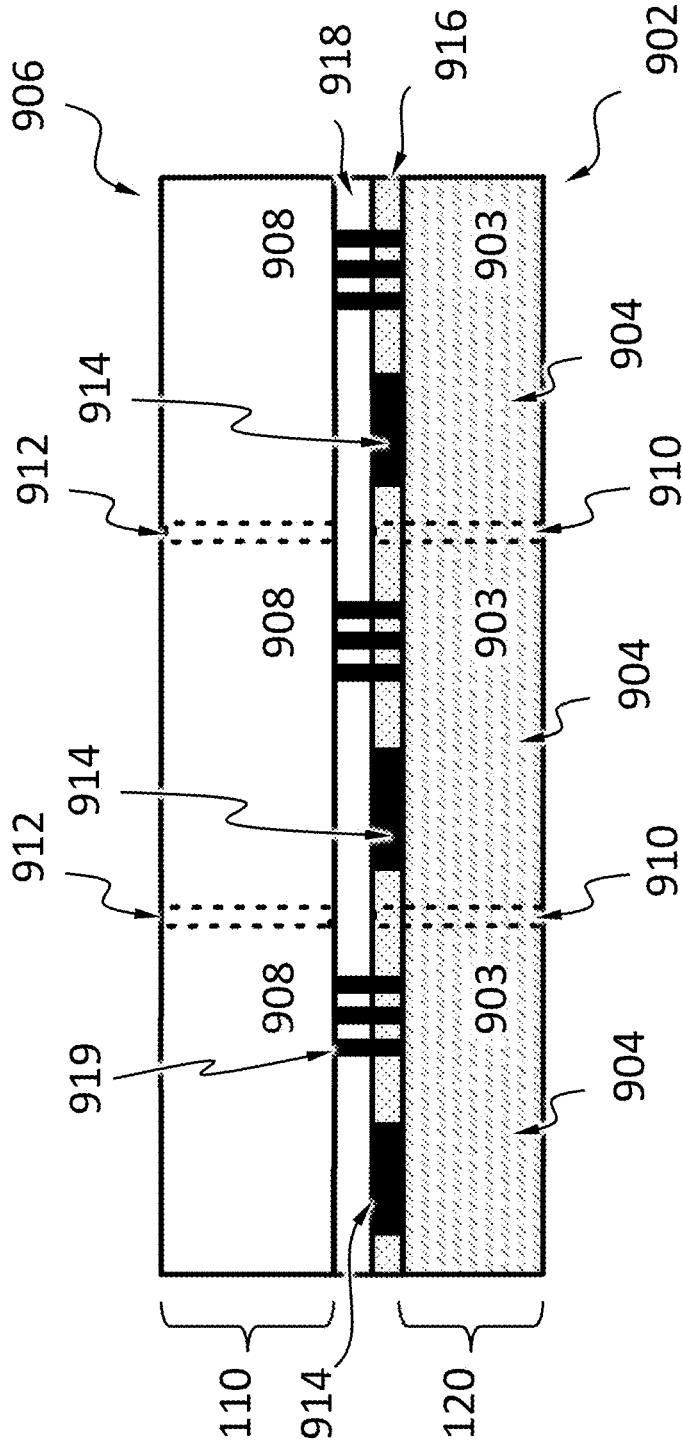

Fig. 10A

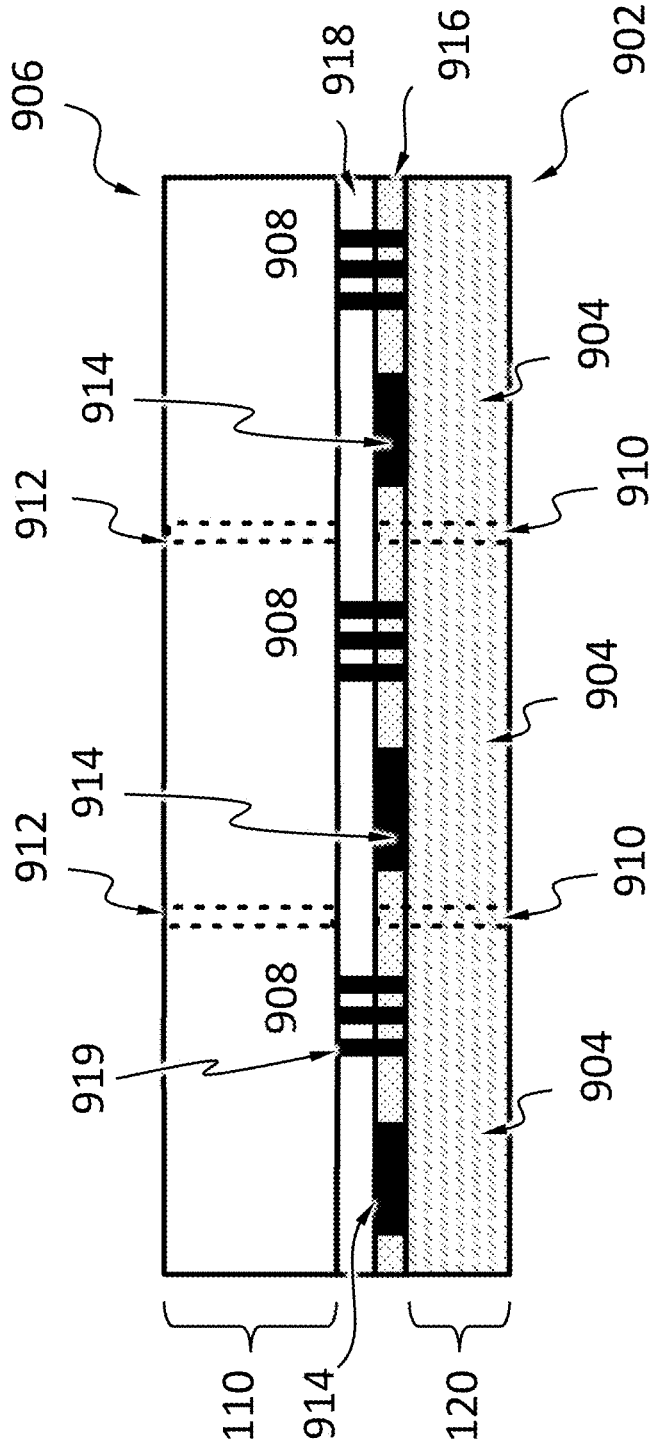

Fig. 10B

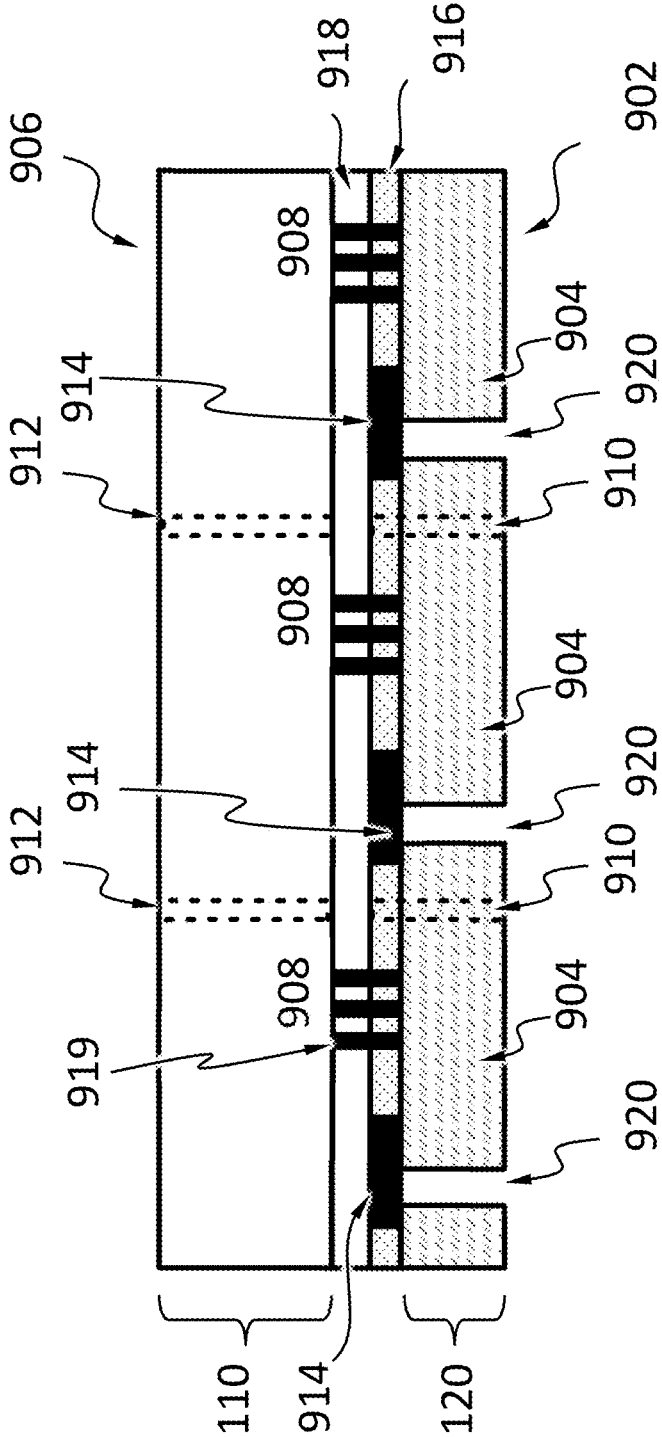

Fig. 10C

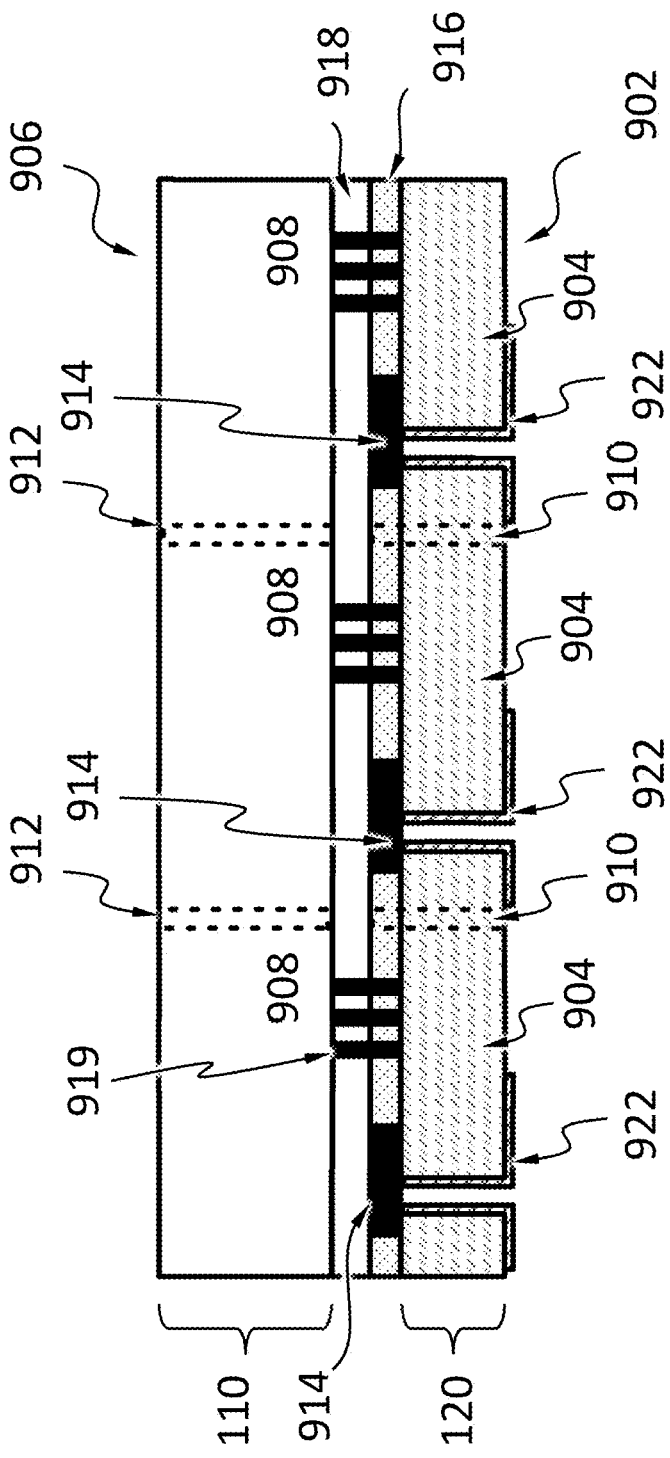

Fig. 10D



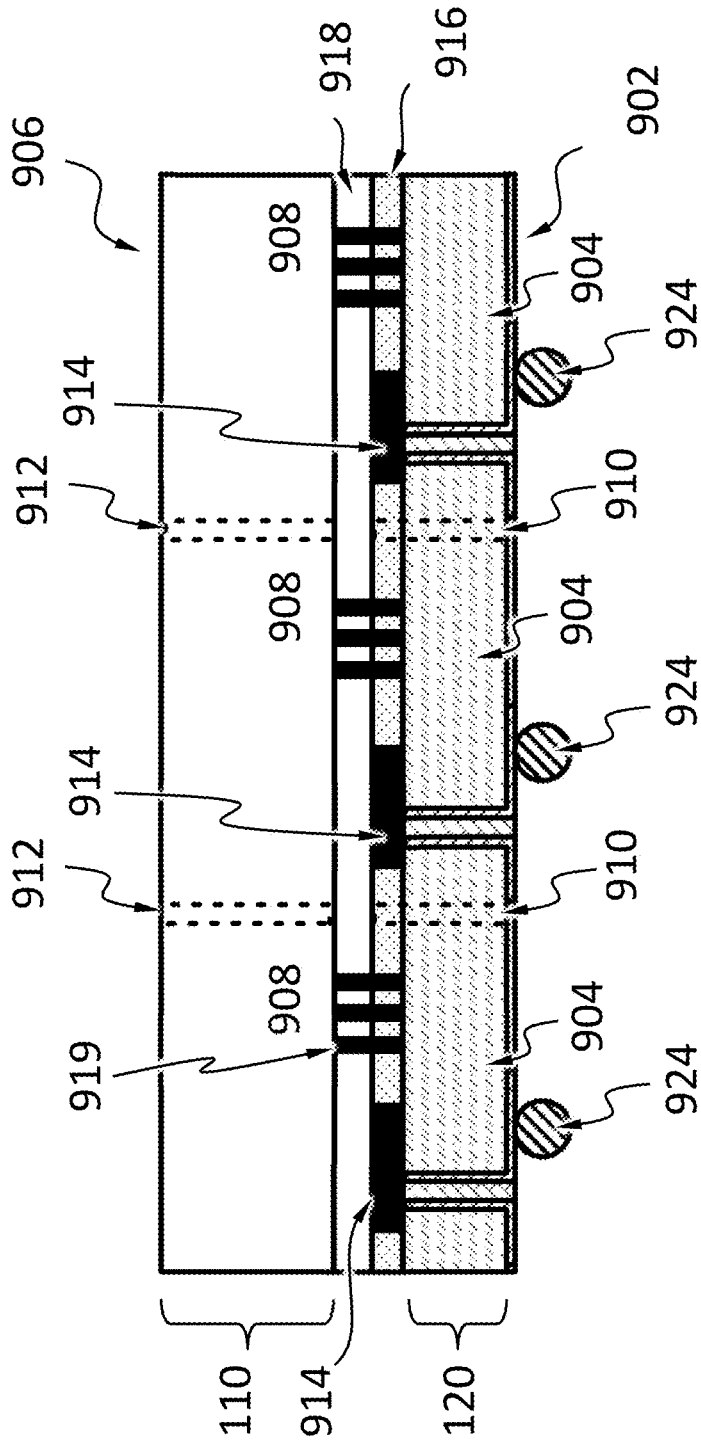

Fig. 10E

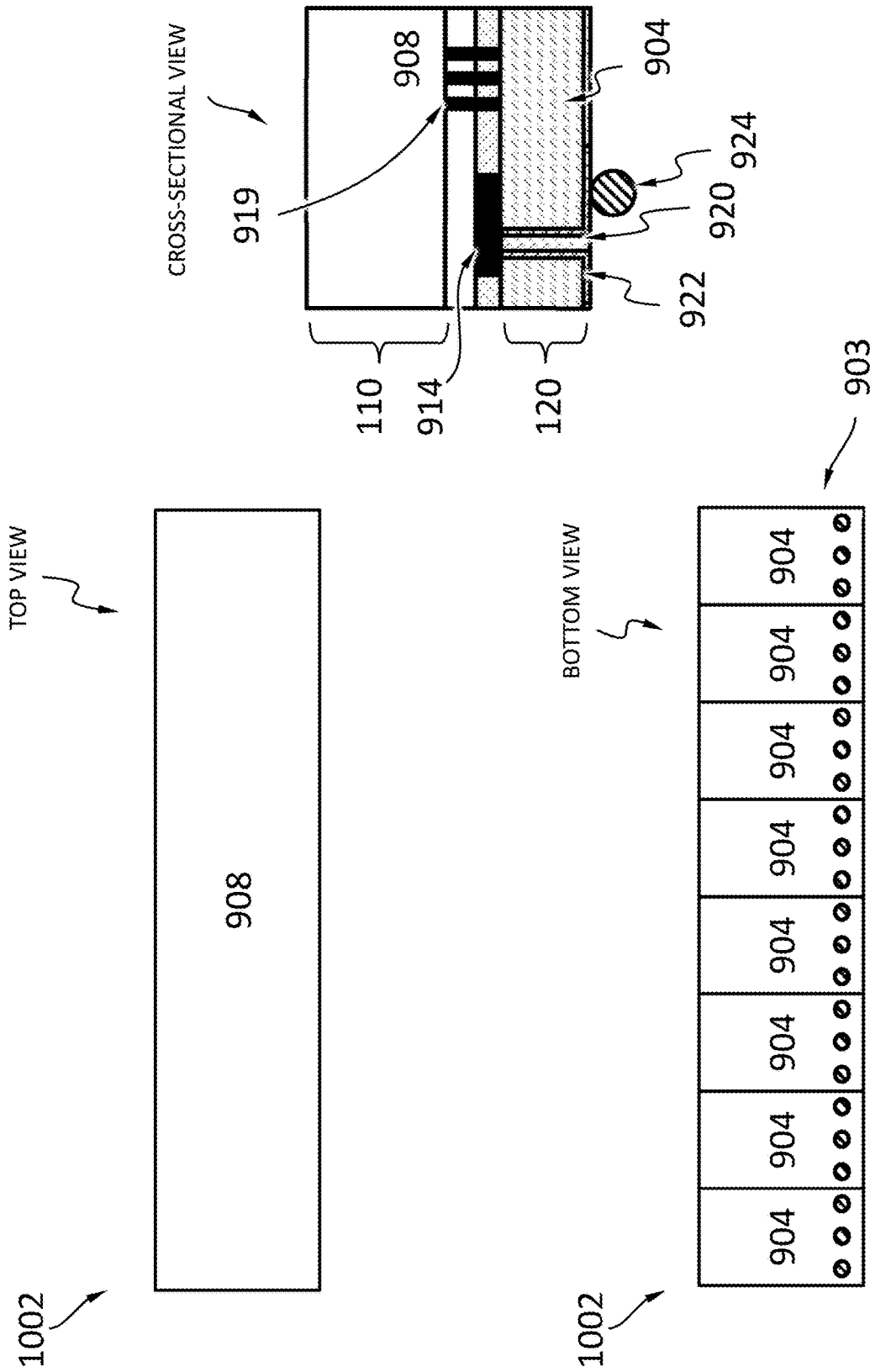

Fig. 10F

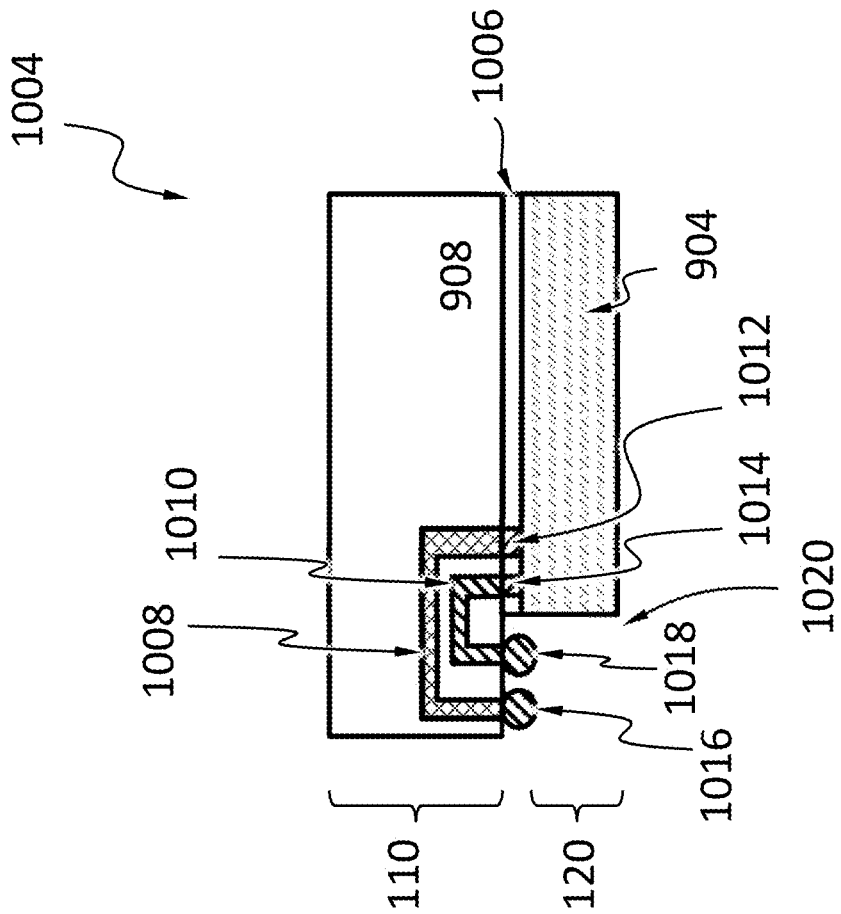

Fig. 10G

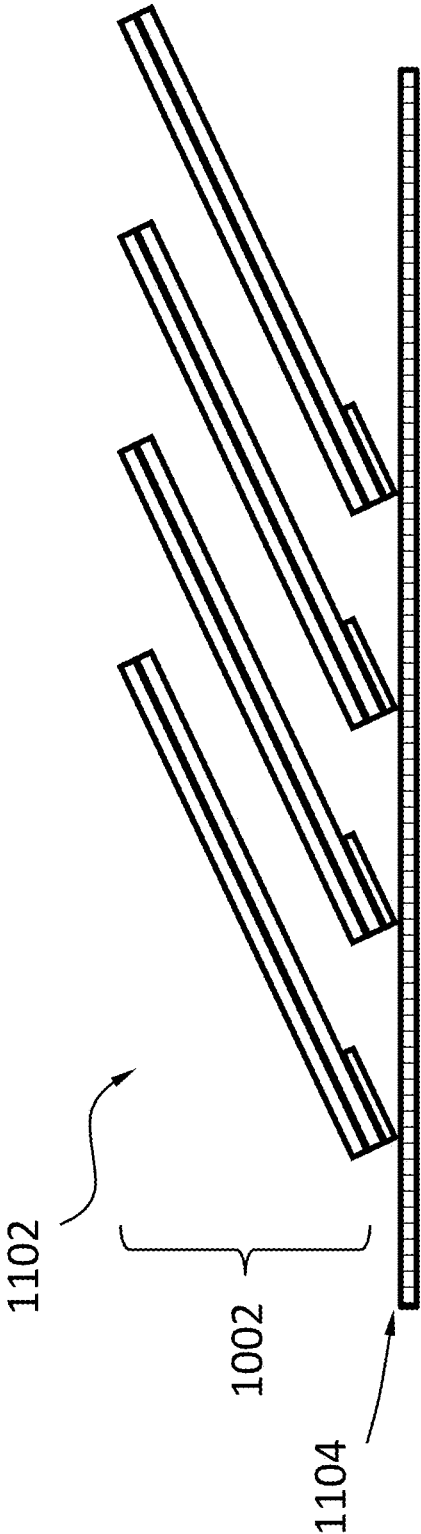

Fig. 11A

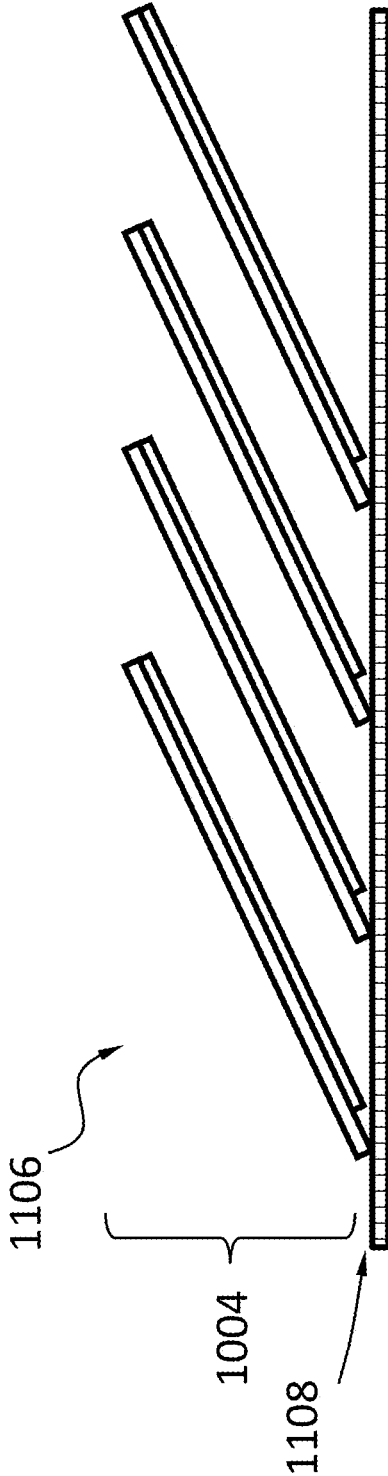

Fig. 11B

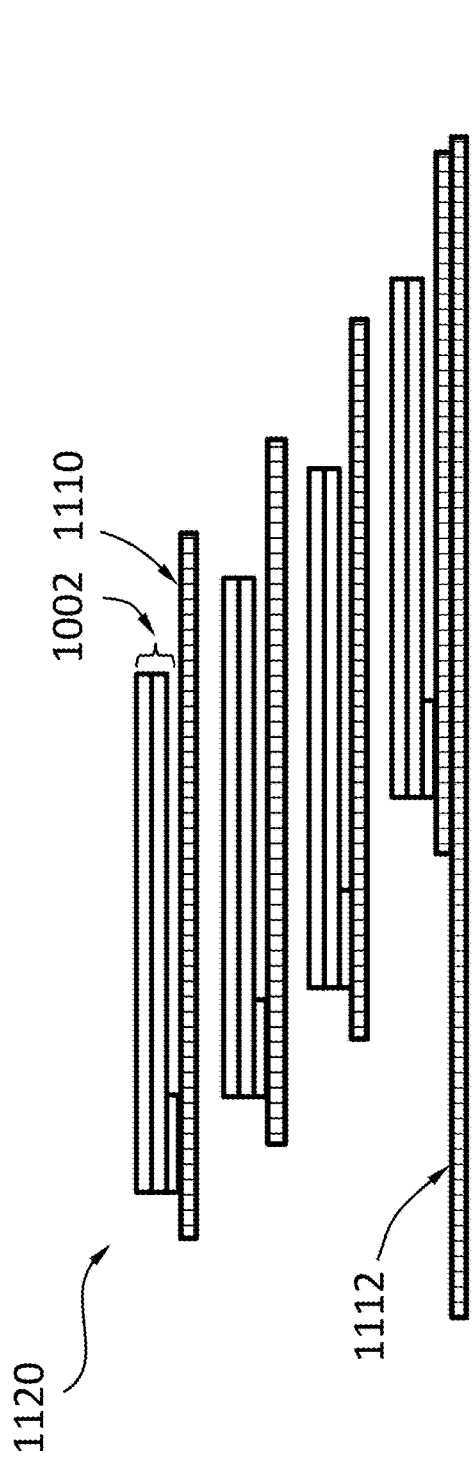

Fig. 11C

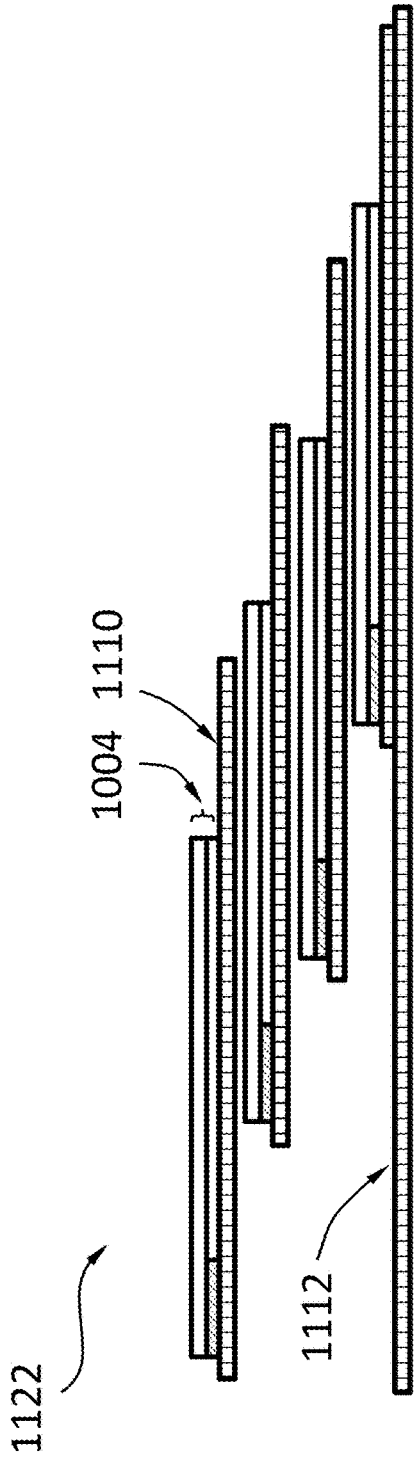

Fig. 11D

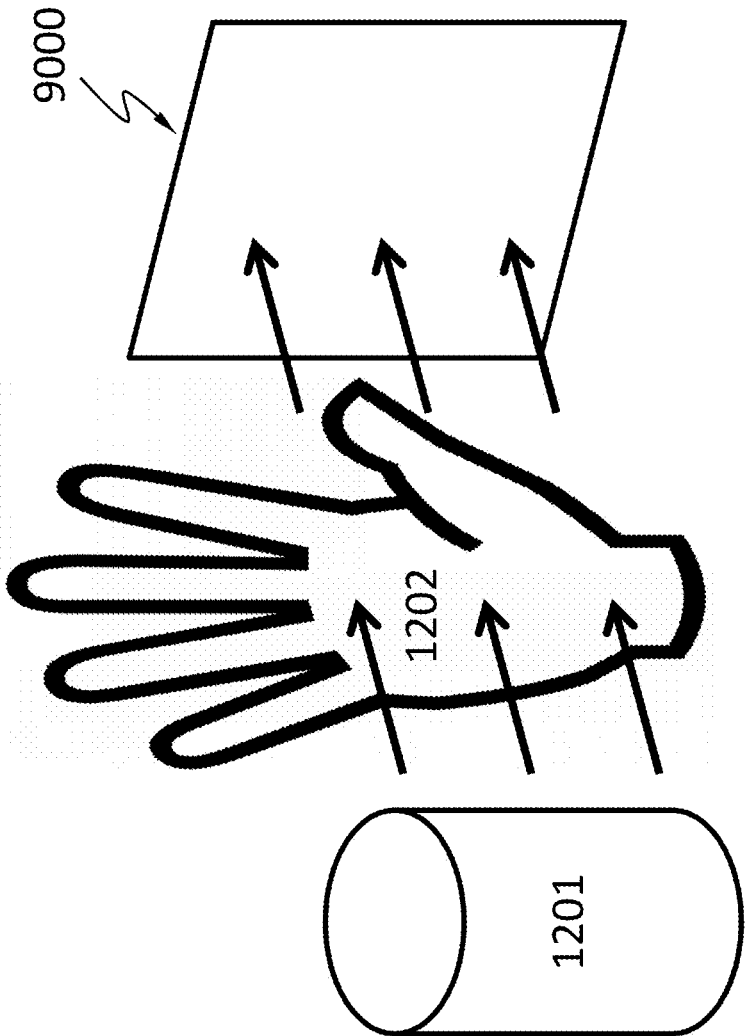

Fig. 12

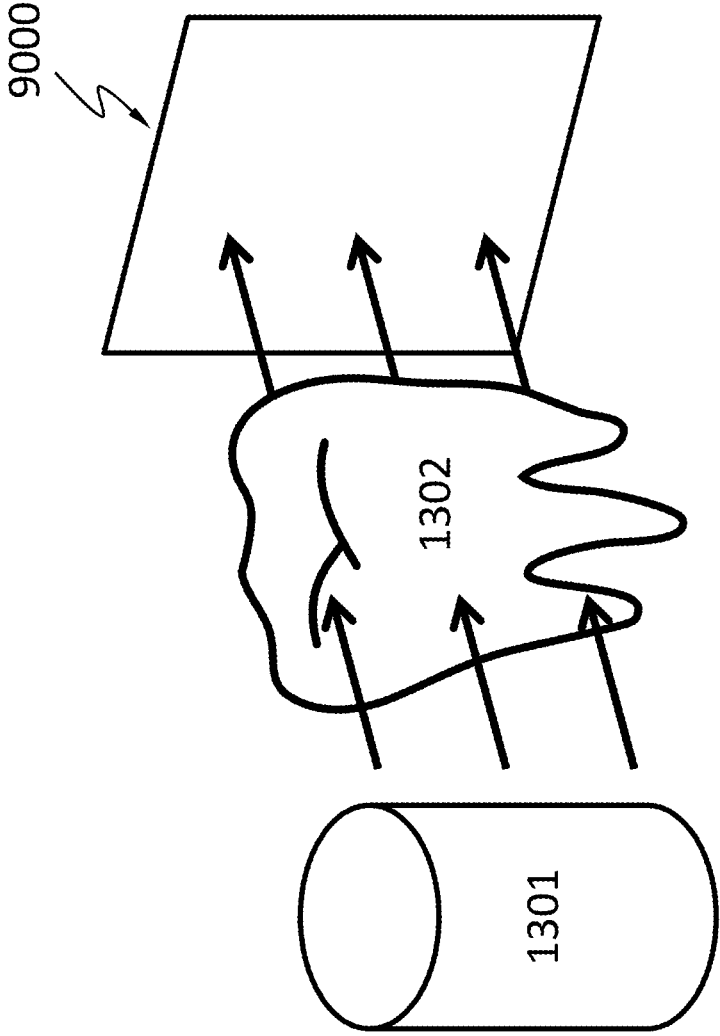

Fig. 13

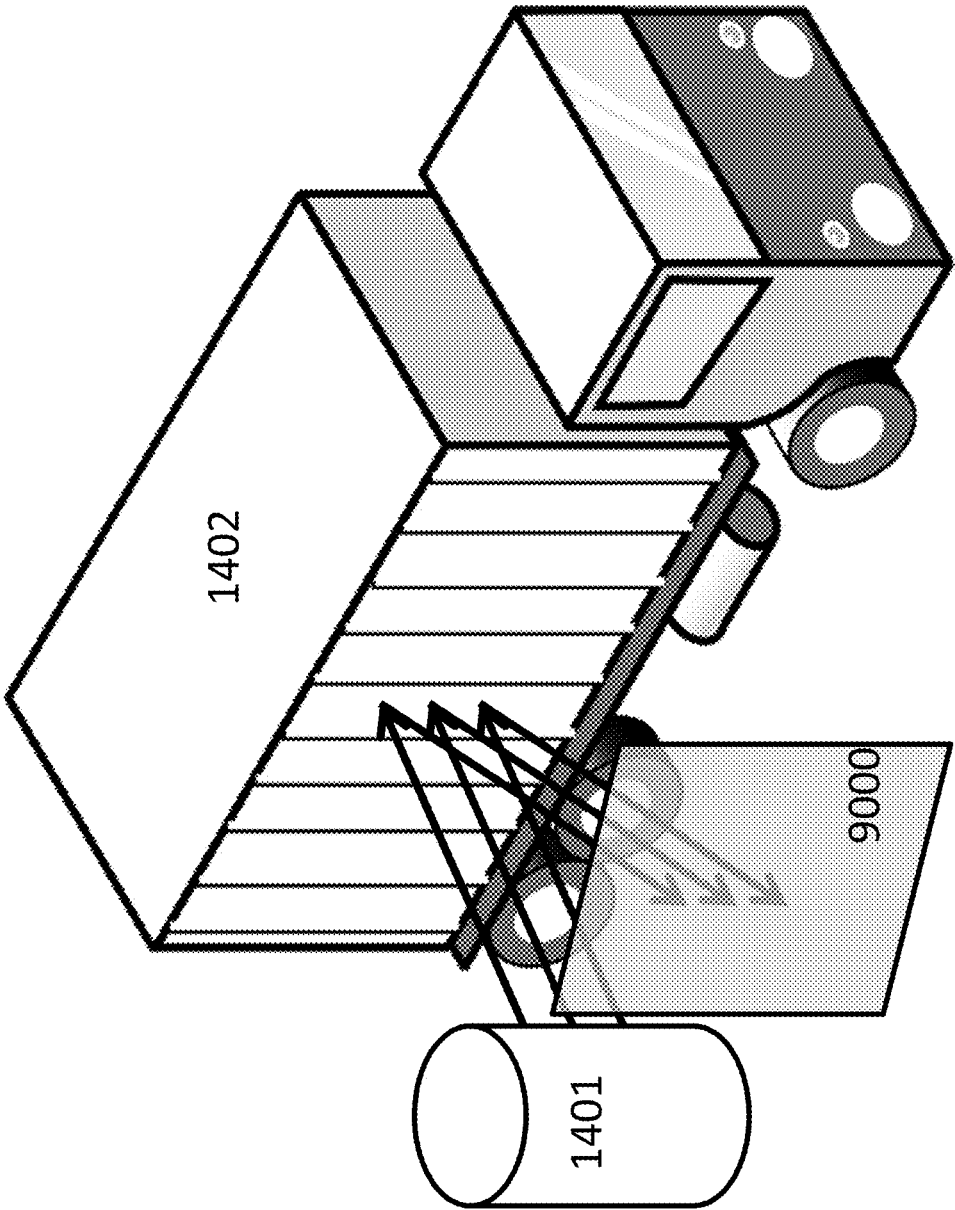

Fig. 14



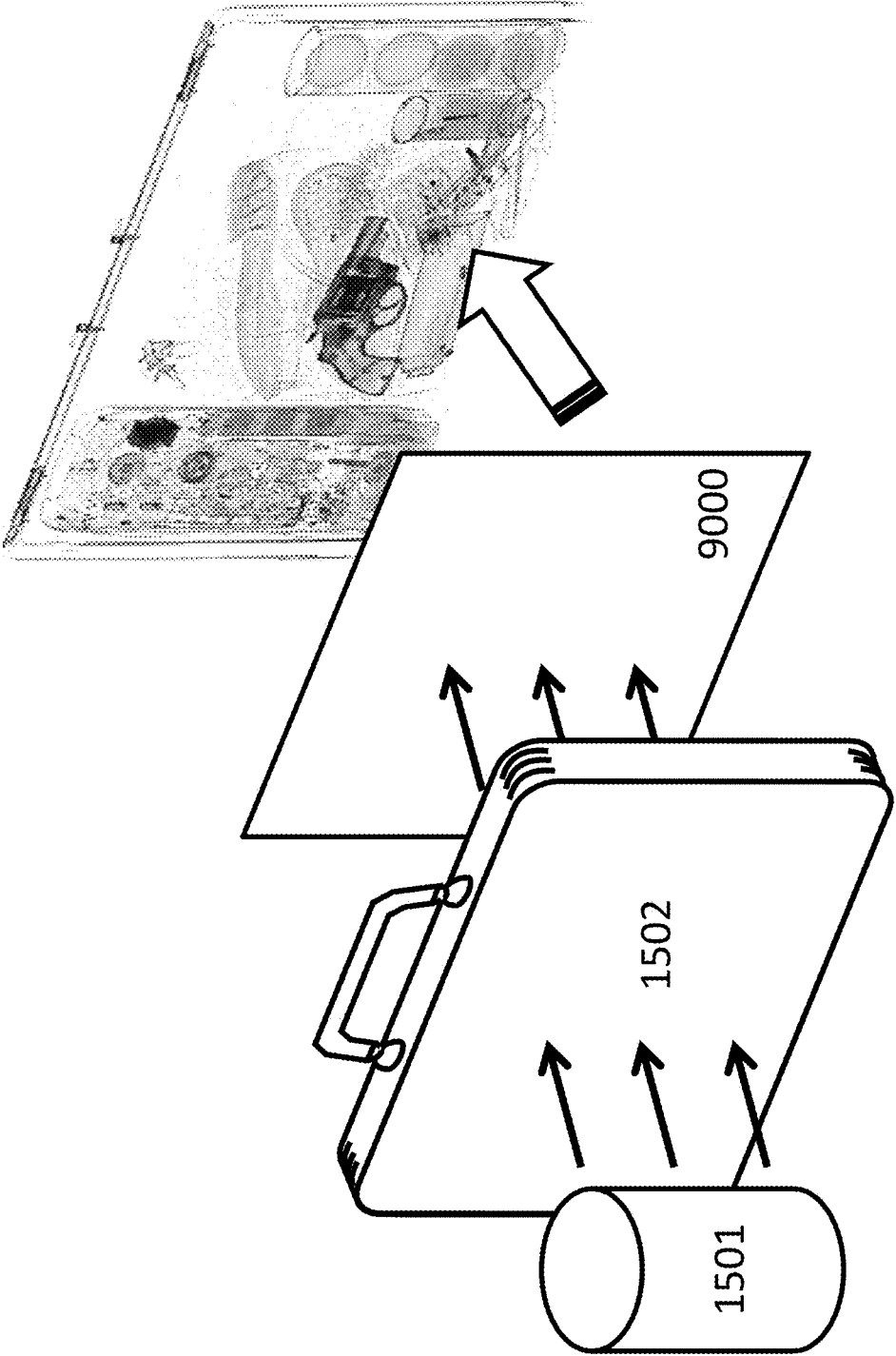

Fig. 15

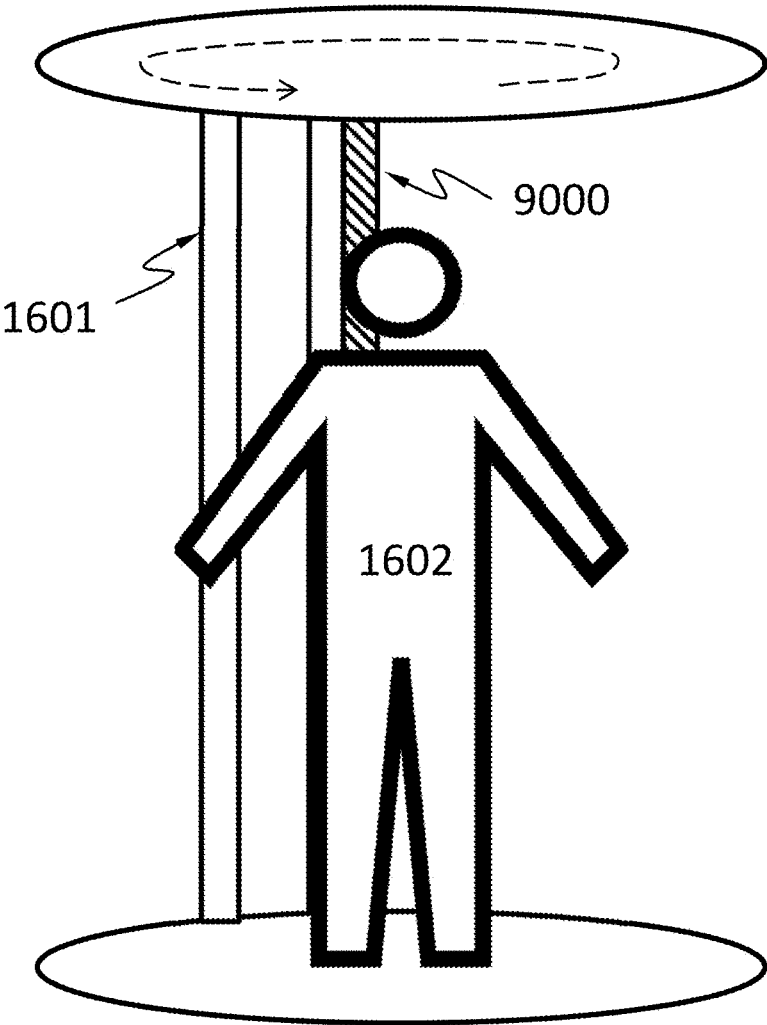

Fig. 16

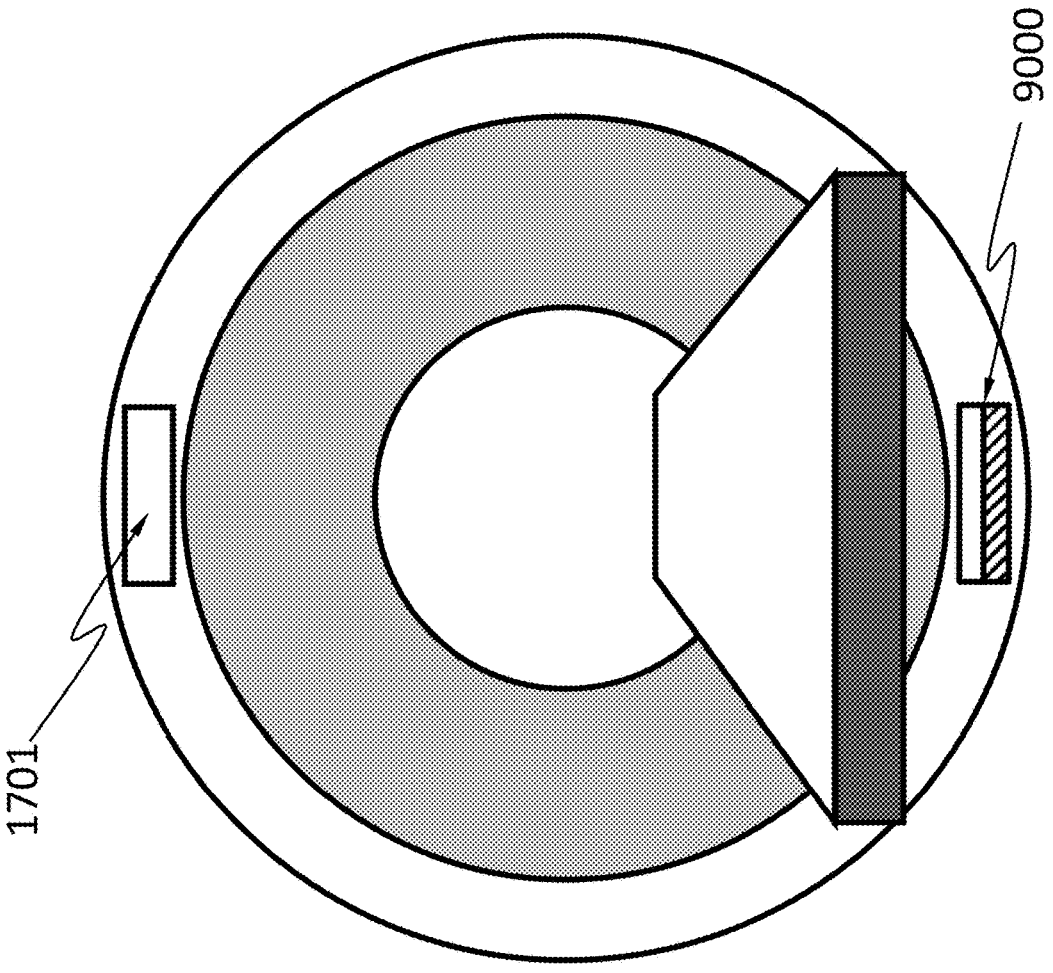

Fig. 17

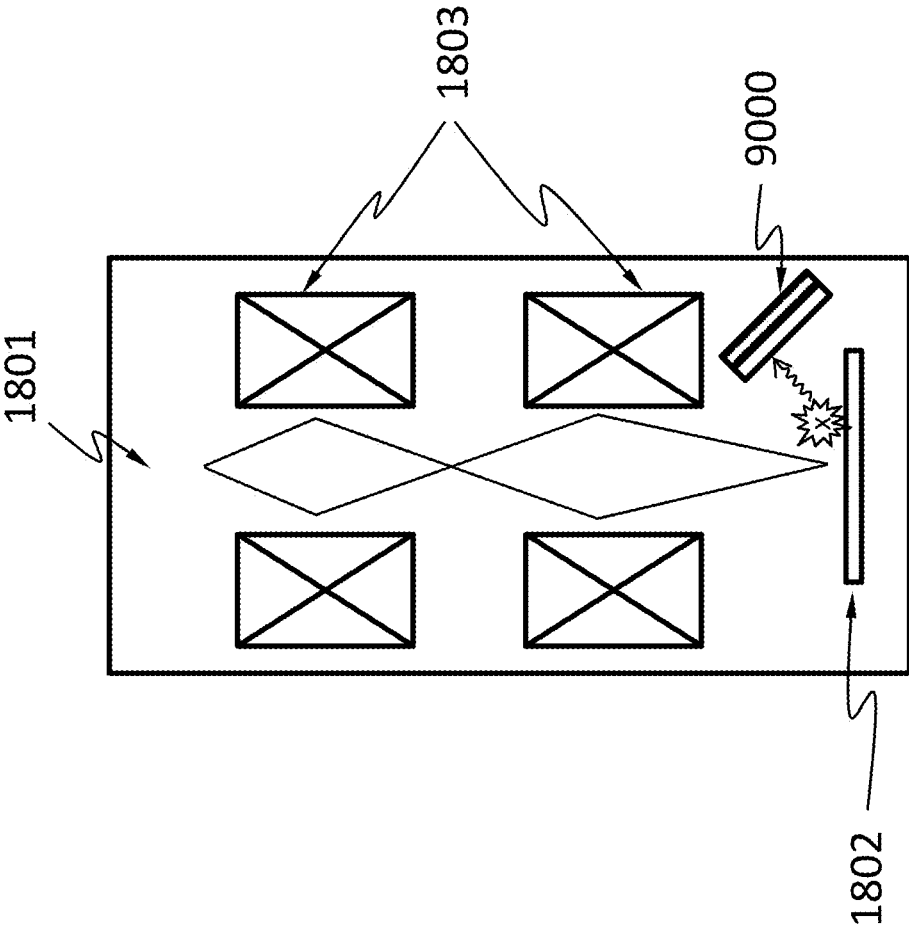

Fig. 18

## METHODS OF MAKING SEMICONDUCTOR X-RAY DETECTOR

### TECHNICAL FIELD

[0001] The disclosure herein relates to X-ray detectors, particularly relates to methods of making semiconductor X-ray detectors.

### BACKGROUND

[0002] X-ray detectors may be devices used to measure the flux, spatial distribution, spectrum or other properties of X-rays.

[0003] X-ray detectors may be used for many applications. One important application is imaging. X-ray imaging is a radiography technique and can be used to reveal the internal structure of a non-uniformly composed and opaque object such as the human body.

[0004] Early X-ray detectors for imaging include photographic plates and photographic films. A photographic plate may be a glass plate with a coating of light-sensitive emulsion. Although photographic plates were replaced by photographic films, they may still be used in special situations due to the superior quality they offer and their extreme stability. A photographic film may be a plastic film (e.g., a strip or sheet) with a coating of light-sensitive emulsion.

[0005] In the 1980s, photostimulable phosphor plates (PSP plates) became available. A PSP plate may contain a phosphor material with color centers in its lattice. When the PSP plate is exposed to X-ray, electrons excited by X-ray are trapped in the color centers until they are stimulated by a laser beam scanning over the plate surface. As the plate is scanned by laser, trapped excited electrons give off light, which is collected by a photomultiplier tube. The collected light is converted into a digital image. In contrast to photographic plates and photographic films, PSP plates can be reused.

[0006] Another kind of X-ray detectors are X-ray image intensifiers. Components of an X-ray image intensifier are usually sealed in a vacuum. In contrast to photographic plates, photographic films, and PSP plates, X-ray image intensifiers may produce real-time images, i.e., do not require post-exposure processing to produce images. X-ray first hits an input phosphor (e.g., cesium iodide) and is converted to visible light. The visible light then hits a photocathode (e.g., a thin metal layer containing cesium and antimony compounds) and causes emission of electrons. The number of emitted electrons is proportional to the intensity of the incident X-ray. The emitted electrons are projected, through electron optics, onto an output phosphor and cause the output phosphor to produce a visible-light image.

[0007] Scintillators operate somewhat similarly to X-ray image intensifiers in that scintillators (e.g., sodium iodide) absorb X-ray and emit visible light, which can then be detected by a suitable image sensor for visible light. In scintillators, the visible light spreads and scatters in all directions and thus reduces spatial resolution. Reducing the scintillator thickness helps to improve the spatial resolution but also reduces absorption of X-ray. A scintillator thus has to strike a compromise between absorption efficiency and resolution.

[0008] Semiconductor X-ray detectors largely overcome this problem by direct conversion of X-ray into electric signals. A semiconductor X-ray detector may include a

semiconductor layer that absorbs X-ray in wavelengths of interest. When an X-ray photon is absorbed in the semiconductor layer, multiple charge carriers (e.g., electrons and holes) are generated and swept under an electric field towards electrical contacts on the semiconductor layer. Cumbersome heat management required in currently available semiconductor X-ray detectors (e.g., Medipix) can make a detector with a large area and a large number of pixels difficult or impossible to produce.

### SUMMARY

[0009] Disclosed herein is an image sensor comprising: one or more packages of semiconductor radiation detectors; wherein each of the one or more packages comprises a radiation detector, wherein the radiation detector comprises a radiation absorption layer on a first strip of semiconductor wafer and an electronics layer on a second strip of semiconductor wafer, wherein the radiation absorption layer is continuous along the first strip of semiconductor wafer with no coverage gap, wherein the first strip and the second strip are longitudinally aligned and bonded together.

[0010] According to an embodiment, at least one of the one or more packages comprises a plurality of radiation detectors mounted on a printed circuit board (PCB), each of the plurality of radiation detectors is tilted relative to the PCB and electrically connected to the PCB.

[0011] According to an embodiment, at least one of the plurality of radiation detectors partially overlap with another one of the plurality of radiation detectors.

[0012] According to an embodiment, the plurality of radiation detectors are arranged such that light incident in an area of the at least one package is detectable by at least one of the radiation detector.

[0013] According to an embodiment, the plurality of radiation detectors are arranged such that light incident in an area of the at least one package is detectable by at least two of the radiation detectors.

[0014] According to an embodiment, the electronics layer comprises transmission lines at a first surface of the second strip of semiconductor wafer bonded to the first strip of semiconductor wafer.

[0015] According to an embodiment, the electronics layer comprises vias electrically connected to the transmission lines.

[0016] According to an embodiment, the second strip of semiconductor wafer comprise a redistribution layer (RDL) electrically connected to the vias.

[0017] According to an embodiment, the radiation absorption layer comprises electrical connections electrically connected to the electrical contacts of the electronics layer.

[0018] According to an embodiment, the electrical connections comprise doped regions in the first strip of semiconductor wafer.

[0019] According to an embodiment, the one or more packages comprise a first group of radiation detectors bonded and electrically connected to a first PCB and a second group of the radiation detectors bonded and electrically connected to a second PCB, the first PCB and the second PCB are bonded and electrically connected to a system PCB.

[0020] According to an embodiment, the first group of radiation detectors at least partially overlap with the second group of radiation detectors.

[0021] According to an embodiment, the radiation absorption layer is configured to detect one of electromagnetic radiation including ultraviolet (UV), X-ray, gamma ray.

[0022] According to an embodiment, the radiation absorption layer is configured to detect one of particle radiation including alpha particles, beta particles and neutron particles.

[0023] According to an embodiment, the radiation absorption layer comprises an electrode and the electronics layer comprises an electronics system, the electronics system comprises: a first voltage comparator configured to compare a voltage of the electrode to a first threshold; a second voltage comparator configured to compare the voltage to a second threshold; a counter configured to register a number of radiation photons or particles reaching the radiation absorption layer; a controller; wherein the controller is configured to start a time delay from a time at which the first voltage comparator determines that an absolute value of the voltage equals or exceeds an absolute value of the first threshold; wherein the controller is configured to activate the second voltage comparator during the time delay; wherein the controller is configured to cause the number registered by the counter to increase by one, if the second voltage comparator determines that an absolute value of the voltage equals or exceeds an absolute value of the second threshold.

[0024] According to an embodiment, the electronics system further comprises a capacitor module electrically connected to the electrode, and the capacitor module is configured to collect charge carriers from the electrode.

[0025] According to an embodiment, the controller is configured to activate the second voltage comparator at a beginning or expiration of the time delay.

[0026] According to an embodiment, wherein the electronics system further comprises a voltmeter, wherein the controller is configured to cause the voltmeter to measure the voltage upon expiration of the time delay.

[0027] According to an embodiment, the controller is configured to determine an X-ray photon energy based on a value of the voltage measured upon expiration of the time delay.

[0028] According to an embodiment, the controller is configured to connect the electrode to an electrical ground.

[0029] According to an embodiment, a rate of change of the voltage is substantially zero at expiration of the time delay.

[0030] According to an embodiment, a rate of change of the voltage is substantially non-zero at expiration of the time delay.

[0031] Disclosed herein is a system comprising the image sensor disclosed herein and an X-ray source, wherein the system is configured to perform X-ray radiography on human chest or abdomen.

[0032] Disclosed herein is a system comprising the image sensor disclosed herein and an X-ray source, wherein the system is configured to perform X-ray radiography on human mouth.

[0033] Disclosed herein is a cargo scanning or non-intrusive inspection (NII) system, comprising the image sensor disclosed herein and an X-ray source, wherein the cargo scanning or non-intrusive inspection (NII) system is configured to form an image using backscattered X-ray.

[0034] Disclosed herein is a cargo scanning or non-intrusive inspection (NII) system, comprising the image sensor disclosed herein and an X-ray source, wherein the cargo

scanning or non-intrusive inspection (NII) system is configured to form an image using X-ray transmitted through an object inspected.

[0035] Disclosed herein is a full-body scanner system comprising the image sensor disclosed herein and an X-ray source.

[0036] Disclosed herein is an X-ray computed tomography (X-ray CT) system comprising the image sensor disclosed herein and an X-ray source.

[0037] Disclosed herein is an electron microscope comprising the image sensor disclosed herein, an electron source and an electronic optical system.

[0038] Disclosed herein is a system comprising the image sensor disclosed herein, wherein the system is an X-ray telescope, or an X-ray microscopy, or wherein the system is configured to perform mammography, industrial defect detection, microradiography, casting inspection, weld inspection, or digital subtraction angiography.

[0039] Disclosed herein is a method of making the image sensor disclosed herein, wherein the method comprises: making the semiconductor radiation detector, comprising: obtaining the first strip of semiconductor wafer comprising the radiation absorption layer; obtaining the second strip of semiconductor wafer comprising the electronics layer; bonding the first strip and the second strip along a longitudinal direction; thinning the second strip; forming vias through the second semiconductor wafer; forming redistribution layer (RDL) metalization; covering the surface of the semiconductor wafers by passivation; and forming electrical contacts to the semiconductor radiation detector.

[0040] According to an embodiment, the electrical contacts added to the semiconductor radiation detectors are solder balls, plugs, pads, or receptacles.

#### BRIEF DESCRIPTION OF FIGURES

[0041] FIG. 1A schematically shows a semiconductor X-ray detector, according to an embodiment.

[0042] FIG. 1B shows a semiconductor X-ray detector 100, according an embodiment.

[0043] FIG. 2 shows an exemplary top view of a portion of the detector in FIG. 1A, according to an embodiment.

[0044] FIG. 3A and FIG. 3B each show a component diagram of an electronics system of the detector in FIG. 1A of FIG. 1B, according to an embodiment.

[0045] FIG. 4 schematically shows a temporal change of the electric current flowing through an electrode (upper curve) of a diode or an electrical contact of a resistor of an X-ray absorption layer exposed to X-ray, the electric current caused by charge carriers generated by an X-ray photon incident on the X-ray absorption layer, and a corresponding temporal change of the voltage of the electrode (lower curve), according to an embodiment.

[0046] FIG. 5 schematically shows a temporal change of the electric current flowing through the electrode (upper curve) caused by noise (e.g., dark current), and a corresponding temporal change of the voltage of the electrode (lower curve), in the electronics system operating in the way shown in FIG. 4, according to an embodiment.

[0047] FIG. 6 schematically shows a temporal change of the electric current flowing through an electrode (upper curve) of the X-ray absorption layer exposed to X-ray, the electric current caused by charge carriers generated by an X-ray photon incident on the X-ray absorption layer, and a corresponding temporal change of the voltage of the elec-

trode (lower curve), when the electronics system operates to detect incident X-ray photons at a higher rate, according to an embodiment.

**[0048]** FIG. 7 schematically shows a temporal change of the electric current flowing through the electrode (upper curve) caused by noise (e.g., dark current), and a corresponding temporal change of the voltage of the electrode (lower curve), in the electronics system operating in the way shown in FIG. 6, according to an embodiment.

**[0049]** FIG. 8 schematically shows a temporal change of the electric current flowing through the electrode (upper curve) caused by charge carriers generated by a series of X-ray photons incident on the X-ray absorption layer, and a corresponding temporal change of the voltage of the electrode, in the electronics system operating in the way shown in FIG. 6 with RST expires before  $t_e$ , according to an embodiment.

**[0050]** FIG. 9 schematically shows a first semiconductor wafer with strips of X-ray absorption layer and a second semiconductor wafer with strips of electronics layer, according to an embodiment.

**[0051]** FIG. 10A schematically shows the semiconductor wafers with strips of X-ray absorption layer and electronics layer of FIG. 9 are aligned and bonded together, according to an embodiment.

**[0052]** FIG. 10B schematically shows the semiconductor wafer with strips of electronics layer in FIG. 10A is thinned, according to an embodiment.

**[0053]** FIG. 10C schematically shows vias are etched and sidewall insulation are added on the semiconductor wafer with strips of electronics layer in FIG. 10B, according to an embodiment.

**[0054]** FIG. 10D schematically shows via and redistribution layer (RDL) metalization on the semiconductor wafer with strips of electronics layer in FIG. 10C, according to an embodiment.

**[0055]** FIG. 10E schematically shows passivation and addition of solder balls of the semiconductor wafer with strips of electronics layer in FIG. 10D, according to an embodiment.

**[0056]** FIG. 10F schematically shows a top view, a bottom view and a cross-sectional view of a semiconductor X-ray detector according to an embodiment.

**[0057]** FIG. 10G schematically shows a cross-sectional view of another semiconductor X-ray detector according to an embodiment.

**[0058]** FIG. 11A schematically shows a package of a plurality of semiconductor X-ray detectors according to an embodiment.

**[0059]** FIG. 11B schematically shows another package of a plurality of semiconductor X-ray detectors according to an embodiment.

**[0060]** FIG. 11C schematically shows yet another package of a plurality of semiconductor X-ray detectors according to an embodiment.

**[0061]** FIG. 11D schematically shows still another package of a plurality of semiconductor X-ray detectors according to an embodiment.

**[0062]** FIG. 12 schematically shows a system comprising the semiconductor X-ray detector described herein, suitable for medical imaging such as chest X-ray radiography, abdominal X-ray radiography, etc., according to an embodiment

**[0063]** FIG. 13 schematically shows a system comprising the semiconductor X-ray detector described herein suitable for dental X-ray radiography, according to an embodiment.

**[0064]** FIG. 14 schematically shows a cargo scanning or non-intrusive inspection (NII) system comprising the semiconductor X-ray detector described herein, according to an embodiment.

**[0065]** FIG. 15 schematically shows another cargo scanning or non-intrusive inspection (NII) system comprising the semiconductor X-ray detector described herein, according to an embodiment.

**[0066]** FIG. 16 schematically shows a full-body scanner system comprising the semiconductor X-ray detector described herein, according to an embodiment.

**[0067]** FIG. 17 schematically shows an X-ray computed tomography (X-ray CT) system comprising the semiconductor X-ray detector described herein, according to an embodiment.

**[0068]** FIG. 18 schematically shows an electron microscope comprising the semiconductor X-ray detector described herein, according to an embodiment.

#### DETAILED DESCRIPTION

**[0069]** FIG. 1A schematically shows a semiconductor X-ray detector **100**, according an embodiment. The semiconductor X-ray detector **100** may include an X-ray absorption layer **110** and an electronics layer **120** (e.g., an ASIC) for processing or analyzing electrical signals incident X-ray generates in the X-ray absorption layer **110**. In an embodiment, the semiconductor X-ray detector **100** does not comprise a scintillator. The X-ray absorption layer **110** may include a semiconductor material such as, silicon, germanium, GaAs, CdTe, CdZnTe, or a combination thereof. The semiconductor may have a high mass attenuation coefficient for the X-ray energy of interest. The X-ray absorption layer **110** may include one or more diodes (e.g., p-i-n or p-n) formed by a first doped region **111**, one or more discrete regions **114** of a second doped region **113**. The second doped region **113** may be separated from the first doped region **111** by an optional the intrinsic region **112**. The discrete portions **114** are separated from one another by the first doped region **111** or the intrinsic region **112**. The first doped region **111** and the second doped region **113** have opposite types of doping (e.g., region **111** is p-type and region **113** is n-type, or region **111** is n-type and region **113** is p-type). In the example in FIG. 1A, each of the discrete regions **114** of the second doped region **113** forms a diode with the first doped region **111** and the optional intrinsic region **112**. Namely, in the example in FIG. 1A, the X-ray absorption layer **110** has a plurality of diodes having the first doped region **111** as a shared electrode. The first doped region **111** may also have discrete portions.

**[0070]** FIG. 1B shows a semiconductor X-ray detector **100**, according an embodiment. The semiconductor X-ray detector **100** may include an X-ray absorption layer **110** and an electronics layer **120** (e.g., an ASIC) for processing or analyzing electrical signals incident X-ray generates in the X-ray absorption layer **110**. In an embodiment, the semiconductor X-ray detector **100** does not comprise a scintillator. The X-ray absorption layer **110** may include a semiconductor material such as, silicon, germanium, GaAs, CdTe, CdZnTe, or a combination thereof. The semiconductor may have a high mass attenuation coefficient for the

X-ray energy of interest. The X-ray absorption layer **110** may not include a diode but includes a resistor.

[0071] When an X-ray photon hits the X-ray absorption layer **110** including diodes, it may be absorbed and generate one or more charge carriers by a number of mechanisms. An X-ray photon may generate **10** to **100000** charge carriers. The charge carriers may drift to the electrodes of one of the diodes under an electric field. The field may be an external electric field. The electrical contact **119B** may include discrete portions each of which is in electrical contact with the discrete regions **114**. In an embodiment, the charge carriers may drift in directions such that the charge carriers generated by a single X-ray photon are not substantially shared by two different discrete regions **114** (“not substantially shared” here means less than 5%, less than 2% or less than 1% of these charge carriers flow to a different one of the discrete regions **114** than the rest of the charge carriers). In an embodiment, the charge carriers generated by a single X-ray photon can be shared by two different discrete regions **114**. FIG. 2 shows an exemplary top view of a portion of the device **100** with a 4-by-4 array of discrete regions **114**. Charge carriers generated by an X-ray photon incident around the footprint of one of these discrete regions **114** are not substantially shared with another of these discrete regions **114**. The area around a discrete region **114** in which substantially all (more than 95%, more than 98% or more than 99% of) charge carriers generated by an X-ray photon incident therein flow to the discrete region **114** is called a pixel associated with the discrete region **114**. Namely, less than 5%, less than 2% or less than 1% of these charge carriers flow beyond the pixel. By measuring the drift current flowing into each of the discrete regions **114**, or the rate of change of the voltage of each of the discrete regions **114**, the number of X-ray photons absorbed (which relates to the incident X-ray intensity) and/or the energies thereof in the pixels associated with the discrete regions **114** may be determined. Thus, the spatial distribution (e.g., an image) of incident X-ray intensity may be determined by individually measuring the drift current into each one of an array of discrete regions **114** or measuring the rate of change of the voltage of each one of an array of discrete regions **114**. The pixels may be organized in any suitable array, such as, a square array, a triangular array and a honeycomb array. The pixels may have any suitable shape, such as, circular, triangular, square, rectangular, and hexangular. The pixels may be individually addressable.

[0072] When an X-ray photon hits the X-ray absorption layer **110** including a resistor but not diodes, it may be absorbed and generate one or more charge carriers by a number of mechanisms. An X-ray photon may generate **10** to **100000** charge carriers. The charge carriers may drift to the electrical contacts **119A** and **119B** under an electric field. The field may be an external electric field. The electrical contact **119B** includes discrete portions. In an embodiment, the charge carriers may drift in directions such that the charge carriers generated by a single X-ray photon are not substantially shared by two different discrete portions of the electrical contact **119B** (“not substantially shared” here means less than 5%, less than 2% or less than 1% of these charge carriers flow to a different one of the discrete portions than the rest of the charge carriers). In an embodiment, the charge carriers generated by a single X-ray photon can be shared by two different discrete portions of the electrical contact **119B**. Charge carriers generated by an X-ray photon

incident around the footprint of one of these discrete portions of the electrical contact **119B** are not substantially shared with another of these discrete portions of the electrical contact **119B**. The area around a discrete portion of the electrical contact **119B** in which substantially all (more than 95%, more than 98% or more than 99% of) charge carriers generated by an X-ray photon incident therein flow to the discrete portion of the electrical contact **119B** is called a pixel associated with the discrete portion of the electrical contact **119B**. Namely, less than 5%, less than 2% or less than 1% of these charge carriers flow beyond the pixel associated with the one discrete portion of the electrical contact **119B**. By measuring the drift current flowing into each of the discrete portion of the electrical contact **119B**, or the rate of change of the voltage of each of the discrete portions of the electrical contact **119B**, the number of X-ray photons absorbed (which relates to the incident X-ray intensity) and/or the energies thereof in the pixels associated with the discrete portions of the electrical contact **119B** may be determined. Thus, the spatial distribution (e.g., an image) of incident X-ray intensity may be determined by individually measuring the drift current into each one of an array of discrete portions of the electrical contact **119B** or measuring the rate of change of the voltage of each one of an array of discrete portions of the electrical contact **119B**. The pixels may be organized in any suitable array, such as, a square array, a triangular array and a honeycomb array. The pixels may have any suitable shape, such as, circular, triangular, square, rectangular, and hexangular. The pixels may be individually addressable.

[0073] The electronics layer **120** may include an electronics system **121** suitable for processing or interpreting signals generated by X-ray photons incident on the X-ray absorption layer **110**. The electronics system **121** may include an analog circuitry such as a filter network, amplifiers, integrators, and comparators, or a digital circuitry such as a microprocessors, and memory. The electronics system **121** may include components shared by the pixels or components dedicated to a single pixel. For example, the electronics system **121** may include an amplifier dedicated to each pixel and a microprocessor shared among all the pixels.

[0074] In some embodiments, the absorption layer **110** may be fabricated on one wafer and the electronics layer **120** may be fabricated on a separate wafer. The two wafers may be bonded together. In one embodiment, the electronics system **121** may be electrically connected to the pixels by vias **131**. Space among the vias may be filled with a filler material **130**, which may increase the mechanical stability of the connection of the electronics layer **120** to the X-ray absorption layer **110**. Other bonding techniques are possible to connect the electronics system **121** to the pixels without using vias.

[0075] FIG. 3A and FIG. 3B each show a component diagram of the electronics system **121**, according to an embodiment. The electronics system **121** may include a first voltage comparator **301**, a second voltage comparator **302**, a counter **320**, a switch **305**, a voltmeter **306** and a controller **310**.

[0076] The first voltage comparator **301** is configured to compare the voltage of an electrode of a diode **300** to a first threshold. The diode may be a diode formed by the first doped region **111**, one of the discrete regions **114** of the second doped region **113**, and the optional intrinsic region **112**. Alternatively, the first voltage comparator **301** is con-



figured to compare the voltage of an electrical contact (e.g., a discrete portion of electrical contact 119B) to a first threshold. The first voltage comparator 301 may be configured to monitor the voltage directly, or calculate the voltage by integrating an electric current flowing through the diode or electrical contact over a period of time. The first voltage comparator 301 may be controllably activated or deactivated by the controller 310. The first voltage comparator 301 may be a continuous comparator. Namely, the first voltage comparator 301 may be configured to be activated continuously, and monitor the voltage continuously. The first voltage comparator 301 configured as a continuous comparator reduces the chance that the system 121 misses signals generated by an incident X-ray photon. The first voltage comparator 301 configured as a continuous comparator is especially suitable when the incident X-ray intensity is relatively high. The first voltage comparator 301 may be a clocked comparator, which has the benefit of lower power consumption. The first voltage comparator 301 configured as a clocked comparator may cause the system 121 to miss signals generated by some incident X-ray photons. When the incident X-ray intensity is low, the chance of missing an incident X-ray photon is low because the time interval between two successive photons is relatively long. Therefore, the first voltage comparator 301 configured as a clocked comparator is especially suitable when the incident X-ray intensity is relatively low. The first threshold may be 5-10%, 10%-20%, 20-30%, 30-40% or 40-50% of the maximum voltage one incident X-ray photon may generate in the diode or the resistor. The maximum voltage may depend on the energy of the incident X-ray photon (i.e., the wavelength of the incident X-ray), the material of the X-ray absorption layer 110, and other factors. For example, the first threshold may be 50 mV, 100 mV, 150 mV, or 200 mV.

[0077] The second voltage comparator 302 is configured to compare the voltage to a second threshold. The second voltage comparator 302 may be configured to monitor the voltage directly, or calculate the voltage by integrating an electric current flowing through the diode or the electrical contact over a period of time. The second voltage comparator 302 may be a continuous comparator. The second voltage comparator 302 may be controllably activate or deactivated by the controller 310. When the second voltage comparator 302 is deactivated, the power consumption of the second voltage comparator 302 may be less than 1%, less than 5%, less than 10% or less than 20% of the power consumption when the second voltage comparator 302 is activated. The absolute value of the second threshold is greater than the absolute value of the first threshold. As used herein, the term “absolute value” or “modulus”  $xv$  of a real number  $x$  is the non-negative value of  $x$  without regard to its sign. Namely,

$$xv = \begin{cases} x, & \text{if } x \geq 0 \\ -x, & \text{if } x < 0 \end{cases}$$

The second threshold may be 200%-300% of the first threshold. The second threshold may be at least 50% of the maximum voltage one incident X-ray photon may generate in the diode or resistor. For example, the second threshold may be 100 mV, 150 mV, 200 mV, 250 mV or 300 mV. The second voltage comparator 302 and the first voltage comparator 310 may be the same component. Namely, the

system 121 may have one voltage comparator that can compare a voltage with two different thresholds at different times.

[0078] The first voltage comparator 301 or the second voltage comparator 302 may include one or more op-amps or any other suitable circuitry. The first voltage comparator 301 or the second voltage comparator 302 may have a high speed to allow the system 121 to operate under a high flux of incident X-ray. However, having a high speed is often at the cost of power consumption.

[0079] The counter 320 is configured to register a number of X-ray photons reaching the diode or resistor. The counter 320 may be a software component (e.g., a number stored in a computer memory) or a hardware component (e.g., a 4017 IC and a 7490 IC).

[0080] The controller 310 may be a hardware component such as a microcontroller and a microprocessor. The controller 310 is configured to start a time delay from a time at which the first voltage comparator 301 determines that the absolute value of the voltage equals or exceeds the absolute value of the first threshold (e.g., the absolute value of the voltage increases from below the absolute value of the first threshold to a value equal to or above the absolute value of the first threshold). The absolute value is used here because the voltage may be negative or positive, depending on whether the voltage of the cathode or the anode of the diode or which electrical contact is used. The controller 310 may be configured to keep deactivated the second voltage comparator 302, the counter 320 and any other circuits the operation of the first voltage comparator 301 does not require, before the time at which the first voltage comparator 301 determines that the absolute value of the voltage equals or exceeds the absolute value of the first threshold. The time delay may expire before or after the voltage becomes stable, i.e., the rate of change of the voltage is substantially zero. The phrase “the rate of change of the voltage is substantially zero” means that temporal change of the voltage is less than 0.1%/ns. The phrase “the rate of change of the voltage is substantially non-zero” means that temporal change of the voltage is at least 0.1%/ns.

[0081] The controller 310 may be configured to activate the second voltage comparator during (including the beginning and the expiration) the time delay. In an embodiment, the controller 310 is configured to activate the second voltage comparator at the beginning of the time delay. The term “activate” means causing the component to enter an operational state (e.g., by sending a signal such as a voltage pulse or a logic level, by providing power, etc.). The term “deactivate” means causing the component to enter a non-operational state (e.g., by sending a signal such as a voltage pulse or a logic level, by cut off power, etc.). The operational state may have higher power consumption (e.g., 10 times higher, 100 times higher, 1000 times higher) than the non-operational state. The controller 310 itself may be deactivated until the output of the first voltage comparator 301 activates the controller 310 when the absolute value of the voltage equals or exceeds the absolute value of the first threshold.

[0082] The controller 310 may be configured to cause the number registered by the counter 320 to increase by one, if, during the time delay, the second voltage comparator 302 determines that the absolute value of the voltage equals or exceeds the absolute value of the second threshold.

**[0083]** The controller 310 may be configured to cause the voltmeter 306 to measure the voltage upon expiration of the time delay. The controller 310 may be configured to connect the electrode to an electrical ground, so as to reset the voltage and discharge any charge carriers accumulated on the electrode. In an embodiment, the electrode is connected to an electrical ground after the expiration of the time delay. In an embodiment, the electrode is connected to an electrical ground for a finite reset time period. The controller 310 may connect the electrode to the electrical ground by controlling the switch 305. The switch may be a transistor such as a field-effect transistor (FET).

**[0084]** In an embodiment, the system 121 has no analog filter network (e.g., a RC network). In an embodiment, the system 121 has no analog circuitry.

**[0085]** The voltmeter 306 may feed the voltage it measures to the controller 310 as an analog or digital signal.

**[0086]** The system 121 may include a capacitor module 309 electrically connected to the electrode of the diode 300 or the electrical contact, wherein the capacitor module is configured to collect charge carriers from the electrode. The capacitor module can include a capacitor in the feedback path of an amplifier. The amplifier configured as such is called a capacitive transimpedance amplifier (CTIA). CTIA has high dynamic range by keeping the amplifier from saturating and improves the signal-to-noise ratio by limiting the bandwidth in the signal path. Charge carriers from the electrode accumulate on the capacitor over a period of time (“integration period”) (e.g., as shown in FIG. 4, between  $t_0$  to  $t_1$ , or  $t_1$ - $t_2$ ). After the integration period has expired, the capacitor voltage is sampled and then reset by a reset switch. The capacitor module can include a capacitor directly connected to the electrode.

**[0087]** FIG. 4 schematically shows a temporal change of the electric current flowing through the electrode (upper curve) caused by charge carriers generated by an X-ray photon incident on the diode or the resistor, and a corresponding temporal change of the voltage of the electrode (lower curve). The voltage may be an integral of the electric current with respect to time. At time  $t_0$ , the X-ray photon hits the diode or the resistor, charge carriers start being generated in the diode or the resistor, electric current starts to flow through the electrode of the diode or the resistor, and the absolute value of the voltage of the electrode or electrical contact starts to increase. At time  $t_1$ , the first voltage comparator 301 determines that the absolute value of the voltage equals or exceeds the absolute value of the first threshold  $V_1$ , and the controller 310 starts the time delay TD1 and the controller 310 may deactivate the first voltage comparator 301 at the beginning of TD1. If the controller 310 is deactivated before  $t_1$ , the controller 310 is activated at  $t_1$ . During TD1, the controller 310 activates the second voltage comparator 302. The term “during” a time delay as used here means the beginning and the expiration (i.e., the end) and any time in between. For example, the controller 310 may activate the second voltage comparator 302 at the expiration of TD1. If during TD1, the second voltage comparator 302 determines that the absolute value of the voltage equals or exceeds the absolute value of the second threshold at time  $t_2$ , the controller 310 causes the number registered by the counter 320 to increase by one. At time  $t_e$ , all charge carriers generated by the X-ray photon drift out of the X-ray absorption layer 110. At time  $t_s$ , the time delay TD1 expires. In the example of FIG. 4, time  $t_s$  is after time

$t_e$ ; namely TD1 expires after all charge carriers generated by the X-ray photon drift out of the X-ray absorption layer 110. The rate of change of the voltage is thus substantially zero at  $t_s$ . The controller 310 may be configured to deactivate the second voltage comparator 302 at expiration of TD1 or at  $t_2$ , or any time in between.

**[0088]** The controller 310 may be configured to cause the voltmeter 306 to measure the voltage upon expiration of the time delay TD1. In an embodiment, the controller 310 causes the voltmeter 306 to measure the voltage after the rate of change of the voltage becomes substantially zero after the expiration of the time delay TD1. The voltage at this moment is proportional to the amount of charge carriers generated by an X-ray photon, which relates to the energy of the X-ray photon. The controller 310 may be configured to determine the energy of the X-ray photon based on voltage the voltmeter 306 measures. One way to determine the energy is by binning the voltage. The counter 320 may have a sub-counter for each bin. When the controller 310 determines that the energy of the X-ray photon falls in a bin, the controller 310 may cause the number registered in the sub-counter for that bin to increase by one. Therefore, the system 121 may be able to detect an X-ray image and may be able to resolve X-ray photon energies of each X-ray photon.

**[0089]** After TD1 expires, the controller 310 connects the electrode to an electric ground for a reset period RST to allow charge carriers accumulated on the electrode to flow to the ground and reset the voltage. After RST, the system 121 is ready to detect another incident X-ray photon. Implicitly, the rate of incident X-ray photons the system 121 can handle in the example of FIG. 4 is limited by  $1/(TD1+RST)$ . If the first voltage comparator 301 has been deactivated, the controller 310 can activate it at any time before RST expires. If the controller 310 has been deactivated, it may be activated before RST expires.

**[0090]** FIG. 5 schematically shows a temporal change of the electric current flowing through the electrode (upper curve) caused by noise (e.g., dark current, background radiation, scattered X-rays, fluorescent X-rays, shared charges from adjacent pixels), and a corresponding temporal change of the voltage of the electrode (lower curve), in the system 121 operating in the way shown in FIG. 4. At time  $t_0$ , the noise begins. If the noise is not large enough to cause the absolute value of the voltage to exceed the absolute value of  $V_1$ , the controller 310 does not activate the second voltage comparator 302. If the noise is large enough to cause the absolute value of the voltage to exceed the absolute value of  $V_1$  at time  $t_1$  as determined by the first voltage comparator 301, the controller 310 starts the time delay TD1 and the controller 310 may deactivate the first voltage comparator 301 at the beginning of TD1. During TD1 (e.g., at expiration of TD1), the controller 310 activates the second voltage comparator 302. The noise is very unlikely large enough to cause the absolute value of the voltage to exceed the absolute value of  $V_2$  during TD1. Therefore, the controller 310 does not cause the number registered by the counter 320 to increase. At time  $t_e$ , the noise ends. At time  $t_s$ , the time delay TD1 expires. The controller 310 may be configured to deactivate the second voltage comparator 302 at expiration of TD1. The controller 310 may be configured not to cause the voltmeter 306 to measure the voltage if the absolute value of the voltage does not exceed the absolute value of  $V_2$  during TD1. After TD1 expires, the controller 310 connects

the electrode to an electric ground for a reset period RST to allow charge carriers accumulated on the electrode as a result of the noise to flow to the ground and reset the voltage. Therefore, the system 121 may be very effective in noise rejection.

**[0091]** FIG. 6 schematically shows a temporal change of the electric current flowing through the electrode (upper curve) caused by charge carriers generated by an X-ray photon incident on the diode or the resistor, and a corresponding temporal change of the voltage of the electrode (lower curve), when the system 121 operates to detect incident X-ray photons at a rate higher than  $1/(TD1+RST)$ . The voltage may be an integral of the electric current with respect to time. At time  $t_0$ , the X-ray photon hits the diode or the resistor, charge carriers start being generated in the diode or the resistor, electric current starts to flow through the electrode of the diode or the electrical contact of resistor, and the absolute value of the voltage of the electrode or the electrical contact starts to increase. At time  $t_1$ , the first voltage comparator 301 determines that the absolute value of the voltage equals or exceeds the absolute value of the first threshold V1, and the controller 310 starts a time delay TD2 shorter than TD1, and the controller 310 may deactivate the first voltage comparator 301 at the beginning of TD2. If the controller 310 is deactivated before  $t_1$ , the controller 310 is activated at  $t_1$ . During TD2 (e.g., at expiration of TD2), the controller 310 activates the second voltage comparator 302. If during TD2, the second voltage comparator 302 determines that the absolute value of the voltage equals or exceeds the absolute value of the second threshold at time  $t_2$ , the controller 310 causes the number registered by the counter 320 to increase by one. At time  $t_e$ , all charge carriers generated by the X-ray photon drift out of the X-ray absorption layer 110. At time  $t_r$ , the time delay TD2 expires. In the example of FIG. 6, time  $t_r$  is before time  $t_e$ ; namely TD2 expires before all charge carriers generated by the X-ray photon drift out of the X-ray absorption layer 110. The rate of change of the voltage is thus substantially non-zero at  $t_r$ . The controller 310 may be configured to deactivate the second voltage comparator 302 at expiration of TD2 or at  $t_2$ , or any time in between.

**[0092]** The controller 310 may be configured to extrapolate the voltage at  $t_e$  from the voltage as a function of time during TD2 and use the extrapolated voltage to determine the energy of the X-ray photon.

**[0093]** After TD2 expires, the controller 310 connects the electrode to an electric ground for a reset period RST to allow charge carriers accumulated on the electrode to flow to the ground and reset the voltage. In an embodiment, RST expires before  $t_e$ . The rate of change of the voltage after RST may be substantially non-zero because all charge carriers generated by the X-ray photon have not drifted out of the X-ray absorption layer 110 upon expiration of RST before  $t_e$ . The rate of change of the voltage becomes substantially zero after  $t_e$  and the voltage stabilized to a residue voltage VR after  $t_e$ . In an embodiment, RST expires at or after  $t_e$ , and the rate of change of the voltage after RST may be substantially zero because all charge carriers generated by the X-ray photon drift out of the X-ray absorption layer 110 at  $t_e$ . After RST, the system 121 is ready to detect another incident X-ray photon. If the first voltage comparator 301 has been deactivated, the controller 310 can activate it at any time before RST expires. If the controller 310 has been deactivated, it may be activated before RST expires.

**[0094]** FIG. 7 schematically shows a temporal change of the electric current flowing through the electrode (upper curve) caused by noise (e.g., dark current, background radiation, scattered X-rays, fluorescent X-rays, shared charges from adjacent pixels), and a corresponding temporal change of the voltage of the electrode (lower curve), in the system 121 operating in the way shown in FIG. 6. At time  $t_0$ , the noise begins. If the noise is not large enough to cause the absolute value of the voltage to exceed the absolute value of V1, the controller 310 does not activate the second voltage comparator 302. If the noise is large enough to cause the absolute value of the voltage to exceed the absolute value of V1 at time  $t_1$  as determined by the first voltage comparator 301, the controller 310 starts the time delay TD2 and the controller 310 may deactivate the first voltage comparator 301 at the beginning of TD2. During TD2 (e.g., at expiration of TD2), the controller 310 activates the second voltage comparator 302. The noise is very unlikely large enough to cause the absolute value of the voltage to exceed the absolute value of V2 during TD2. Therefore, the controller 310 does not cause the number registered by the counter 320 to increase. At time  $t_e$ , the noise ends. At time  $t_r$ , the time delay TD2 expires. The controller 310 may be configured to deactivate the second voltage comparator 302 at expiration of TD2. After TD2 expires, the controller 310 connects the electrode to an electric ground for a reset period RST to allow charge carriers accumulated on the electrode as a result of the noise to flow to the ground and reset the voltage. Therefore, the system 121 may be very effective in noise rejection.

**[0095]** FIG. 8 schematically shows a temporal change of the electric current flowing through the electrode (upper curve) caused by charge carriers generated by a series of X-ray photons incident on the diode or the resistor, and a corresponding temporal change of the voltage of the electrode (lower curve), in the system 121 operating in the way shown in FIG. 6 with RST expires before  $t_e$ . The voltage curve caused by charge carriers generated by each incident X-ray photon is offset by the residue voltage before that photon. The absolute value of the residue voltage successively increases with each incident photon. When the absolute value of the residue voltage exceeds V1 (see the dotted rectangle in FIG. 8), the controller starts the time delay TD2 and the controller 310 may deactivate the first voltage comparator 301 at the beginning of TD2. If no other X-ray photon incidence on the diode or the resistor during TD2, the controller connects the electrode to the electrical ground during the reset time period RST at the end of TD2, thereby resetting the residue voltage. The residue voltage thus does not cause an increase of the number registered by the counter 320.

**[0096]** FIG. 9 schematically shows a first semiconductor wafer 902 with strips 903 of the electronics layer 120 and a second semiconductor wafer 906 with strips 908 of X-ray absorption layer 110. According to one embodiment, the X-ray absorption layer 110 on a strip 908 may be continuous and there may be no gap of absorption coverage within a strip 908 of X-ray absorption layer 110 along a longitudinal direction. Each strip 903 of the electronics layer 120 may comprise a plurality of electronics systems 904. The strips 903 of the electronics layer 120 may be separated by a small gap, e.g., with a width of tens of microns, or hundreds of microns. A strip 903 of the electronics layer 120 may also be referred to as a column of electronics systems. Within a

column, the electronics systems **904** may be kept close to one another with no or little gap. In one embodiment, a column of the electronics systems **904** may be kept intact (i.e. not diced) for making a semiconductor X-ray detector. In another embodiment, each electronics system **904** may be diced into a separate ASIC chip. It should be noted that the number and size for the strips **903** and **908**, and the electronics systems **904** are for illustration only, and may be different in different embodiments. Moreover, in one embodiment, the strips **903** may be diced from the substrate **902** and may be bonded to the semiconductor wafer **906**. Further, in one embodiment, the vias through the semiconductor wafer **902** may be made before or after the dicing.

[0097] FIGS. 10A-10E show a process of making a semiconductor X-ray detector **1002** in FIG. 10F. FIG. 10A schematically shows the semiconductor wafer **906** with strips **908** of X-ray absorption layer **110** and the semiconductor wafer **902** with strips **903** of electronics layer **120** of FIG. 9 are aligned and bonded together by a bonding layer **918**. The semiconductor wafer **902** may comprise a passivation layer **916** at the surface to be bonded with the wafer **906**. A “surface” as used herein is not necessarily exposed, but can be buried wholly or partially. The semiconductor wafer **902** may comprise one or more electrical contacts **919**, which may provide input/output (I/O) contacts for the electronics systems **904** within the electronics layer **120**. The one or more electric contacts **919** may be a layer of metal or doped semiconductor. For example, the electric contacts **919** may be gold, copper, platinum, palladium, doped silicon, etc. In one embodiment, the semiconductor wafer **902** may comprise transmission lines **914** configured to redistribute electric connection to the electronics systems **904** to locations close to an edge of each strip **903** of electronics layer **120**. Gaps **910** (shown as dashed boxes) are the gaps between the strips **903** of electronics layer **120** on the wafer **902**. FIG. 10A is a cross-sectional view where the gaps **910** are shown to be between the electronics systems **904** in neighboring strips **903** of electronics layer **120** and the transmission lines **914** are shown to be close to a side of the electronics system **904**. Gaps **912** (shown as dashed boxes) are the corresponding gaps between the strips **908** of X-ray absorption layer **110** on the wafer **906**.

[0098] FIG. 10B schematically shows the semiconductor wafer **906** with strips **908** of X-ray absorption layer **110** and the semiconductor wafer **902** with strips of electronics layer **120** are aligned and bonded together as shown in FIG. 10A, and further with the semiconductor wafer **902** thinned. For example, the substrate of the semiconductor wafer **902** may have a thickness of 750 microns or less, 200 microns or less, 100 microns or less, 50 microns or less, 20 microns or less, or 5 microns or less. The substrate of the semiconductor wafer **902** may be a silicon substrate or a substrate of other suitable semiconductor or insulator. The thinned substrate may be produced by grinding a thicker substrate to a desired thickness.

[0099] FIG. 10C schematically shows the bonded semiconductor wafer **906** and the semiconductor wafer **902** as shown in FIG. 10B, and further with vias **920** formed in the semiconductor wafer **902** through the electronics layer **120**. The vias **920** are sometimes referred to as “through-silicon vias” although they may be fabricated in substrates of materials other than silicon. In one embodiment, sidewall insulation may be added to the vias **920**.

[0100] FIG. 10D schematically shows the bonded semiconductor wafer **906** and the semiconductor wafer **902** as shown in FIG. 10C, further with vias **920** and redistribution layer (RDL) metalization on the semiconductor wafer **902**. The via **920** and RDL metalization may create an electrical contact layer **922**. The electrical contact layer **922** may cover the sidewalls of the vias **920** and an area on the bottom surface of the semiconductor wafer **902**. The electrical contact layer **922** may comprise one or more transmission lines.

[0101] FIG. 10E schematically shows the bonded semiconductor wafer **906** and the semiconductor wafer **902** as shown in FIG. 10D, further with passivation of the semiconductor wafer **902** and addition of solder balls **924** on the electrical contact layer **922** at the bottom surface. In one embodiment, the solder balls **924** may be applied close to an edge of the electronics system **904**. The electrical contact layer **922** may comprise one or more transmission lines. The electronics system **904** may be electrically connected to the solder balls **924** by the transmission lines **914** and the electrical contact layer **922** through one or more vias **920**. In another embodiment, other type of electrical contacts instead of solder balls may be provided, such as but not limited to, plugs, pads, receptacles.

[0102] In one embodiment, the bonded wafers **902** and **906** may be diced along the gaps **910** and **912** to create one or more radiation detectors. Each radiation detector may include a radiation absorption layer manufactured on a first strip of semiconductor wafer and an electronics layer manufactured on a second strip of semiconductor wafer, and the first strip and the second strip are longitudinally aligned and bonded together.

[0103] FIG. 10F schematically shows a top view, a bottom view and a cross-sectional view of such a semiconductor X-ray detector **1002**. The top view shows a strip **908** from the semiconductor wafer **906** that may comprise the radiation absorption layer (e.g., the X-ray absorption layer **110**). The bottom view shows a strip **903** from the semiconductor wafer **902** that may comprise the electronics layer **120** with the solder balls **924** close to an edge of the strip **903**. The cross-sectional view shows one strip **908** of X-ray absorption layer **110** and the electronics system **904** with the electronics layer **120** bonded, which is just one section of the bonded wafers **902** and **906** shown in FIGS. 10A-10E.

[0104] FIG. 10G schematically shows a cross-sectional view of another semiconductor X-ray detector **1004** according to an embodiment. The semiconductor X-ray detector **1004** may comprise an X-ray absorption layer **110** and an electronics layer **120** as shown and described herein. The X-ray absorption layer **110** may be a strip **908** of the semiconductor wafer **906** and the electronics layer **120** may be a strip **903** of electronics systems **904** from the semiconductor wafer **902** as shown and described herein. In the semiconductor X-ray detector **1004**, the semiconductor wafers **902** and **906** may be bonded by a bonding layer **1006** and the X-ray absorption layer **110** may comprise one or more electrical connections (e.g., the electrical connections **1008** and **1010**). The bonding layer **1006** may comprise one or more vias **1012** and **1014**. The electronics layer **120** may comprise one or more cut offs **1020** on the semiconductor wafer **902** to expose electrical contact pads on the semiconductor wafer **906** for the absorption layer **110**. A cut off **1020** may be a slot through the semiconductor wafer **906**.

[0105] The semiconductor X-ray detector **1004** may further comprise one or more solder balls **1016** and **1018** as electrical contacts for the semiconductor X-ray detector **1004**. The one or more solder balls **1016** and **1018** may be aligned close to a longitudinal edge of the strip **908**. The electronics system **904** may be electrically connected to the solder balls **1016** and **1018** through the vias **1012** and **1014**, and through the electrical connections **1008** and **1010**. Therefore, the electrical signals from the electronics system **904** may go through the absorption layer **110**. In one embodiment, the electrical connections **1008** and **1010** may be doped regions in the X-ray absorption layer **110**. Moreover, in one embodiment, other type of electrical contacts instead of solder balls may be provided, such as but not limited to, plugs, pads, receptacles.

[0106] Bonding of the semiconductor wafer **902** and the semiconductor wafer **906** may be a direct bonding or flip chip bonding. In one embodiment, the bonding (e.g., the layer **918** and layer **1006**) may be a microbump based bonding layer. In another embodiment, another bonding technique may be used to electrically connect the electronics system **904** to the absorption layer **110** without using vias. Moreover, in one embodiment, the semiconductor wafer **906** has no RDL layer and high density interconnect wafer to wafer bonding may be achieved. For example, in microbump based bonding, pitch may be about tens of microns (e.g., 50-70  $\mu\text{m}$ ), hundreds of microns.

[0107] FIG. 11A schematically shows a package **1102** of a plurality of semiconductor X-ray detectors **1002** in an image sensor, according to an embodiment. The plurality of semiconductor X-ray detectors **1002** may be mounted on a printed circuit board (PCB) **1104**, and may be tilted relative to the PCB **1104** such that the solder balls close to the longitudinal edge of the strip **908** of semiconductor wafer may be electrically connected to the PCB **1104**. FIG. 11B schematically shows another package **1106** of a plurality of semiconductor X-ray detectors **1004** in an image sensor, according to an embodiment. The plurality of semiconductor X-ray detectors **1004** may be mounted on a PCB **1108**, and may be tilted relative to the PCB **1108** such that the solder balls close to the longitudinal edge of the strip **903** of semiconductor wafer may be electrically connected to a PCB **1108**. According to another embodiment, the package **1102** may comprise one or more semiconductor X-ray detectors **1004** in addition to one or more semiconductor detectors **1002**, and the package **1106** may comprise one or more semiconductor X-ray detectors **1002** in addition to one or more semiconductor detectors **1004**.

[0108] FIG. 11C schematically shows yet another package **1120** of a plurality of semiconductor X-ray detectors **1002** in an image sensor, according to an embodiment. Each of the plurality of semiconductor X-ray detectors **1002** may be mounted on and electrically connected to a PCB **1110** and the PCBs **1110** may be mounted on and electrically connected to a system PCB **1112**.

[0109] FIG. 11D schematically shows still another package **1122** of a plurality of semiconductor X-ray detectors **1004** in an image sensor, according to an embodiment. Each of the plurality of semiconductors **1004** may be mounted on and electrically connected to a PCB **1110** and the PCBs **1110** may be mounted on and electrically connected to a system PCB **1112**. According to another embodiment, the package **1120** may comprise one or more semiconductor X-ray detectors **1004** in addition to one or more semiconductor

detectors **1002**, and the package **1122** may comprise one or more semiconductor X-ray detectors **1002** in addition to one or more semiconductor detectors **1004**.

[0110] In one or more embodiments, the plurality of semiconductor X-ray detectors (e.g., **1002** and **1004**) in an image sensor may be arranged in parallel and at least partially overlap to cover gaps between the X-ray absorption layers in different strips **908**. Moreover, in one or more embodiments, a plurality of packages of semiconductor X-ray detectors (e.g., **1002** and **1004**) in an image sensor may be stacked and staggered, and the semiconductor X-ray detectors (e.g., **1002** and **1004**) in different packages may be arranged to at least overlap to cover gaps between different semiconductor X-ray detectors such that light incident in an area is detectable by at least one of the packages. Further, in one or more embodiments, a plurality of packages of semiconductor X-ray detectors (e.g., **1002** and **1004**) in an image sensor may be stacked and staggered, and the semiconductor X-ray detectors (e.g., **1002** and **1004**) in different packages may be arranged to overlap such that light incident in an area is detectable by at least two of the packages. The multiple packages stacked and staggered in an image sensor do not have to be the same. For example, a package **1102** and a package **1120** may be stacked and staggered. Moreover, the multiple semiconductor X-ray detectors in a package or stack of an image sensor do not have to be identical. For example, the multiple semiconductor X-ray detectors may differ in thickness, structure, or material.

[0111] According to an embodiment, a semiconductor radiation detector may be obtained using a method including: obtaining a first semiconductor wafer comprising a strip of radiation absorption layer; obtaining a second semiconductor wafer comprising a strip of electronics layer; bonding the first semiconductor and the second semiconductor with the strip of radiation absorption layer and the strip of electronics layer longitudinally aligned; thinning the second semiconductor wafer; obtaining vias through the second semiconductor wafer, wherein the sidewalls of the vias may be insulated; obtaining electrical connections through the vias; and covering the surface of the semiconductor wafers by passivation and adding solder balls to the second semiconductor wafer. In one embodiment, the solder balls may be added close to an edge of the strip of electronics layer. Moreover, in one embodiment, the electrical connections may be obtained by via and RDL metalization.

[0112] FIGS. 12-18 schematically show various systems each comprising an image sensor **9000**. The image sensor **9000** may be an embodiment of an image sensor comprising one or more packages of semiconductor radiation detectors described herein. It should be noted a radiation detector according to an embodiment may be used to detect one or more types of radiation and X-ray is just one example. For example, the radiation may be an electromagnetic radiation such as infrared light, visible light, ultraviolet light, X-ray or  $\gamma$ -ray. The radiation may be of other types such as  $\alpha$ -rays and  $\beta$ -rays.

[0113] FIG. 12 schematically shows a system comprising the image sensor **9000** described herein. The system may be used for medical imaging such as chest X-ray radiography, abdominal X-ray radiography, etc. The system comprises an X-ray source **1201**. X-ray emitted from the X-ray source **1201** penetrates an object **1202** (e.g., a human body part such as chest, limb, abdomen), is attenuated by different degrees by the internal structures of the object **1202** (e.g.,

bones, muscle, fat and organs, etc.), and is projected to the image sensor **9000**. The image sensor **9000** forms an image by detecting the intensity distribution of the X-ray.

**[0114]** FIG. **13** schematically shows a system comprising the image sensor **9000** described herein. The system may be used for medical imaging such as dental X-ray radiography. The system comprises an X-ray source **1301**. X-ray emitted from the X-ray source **1301** penetrates an object **1302** that is part of a mammal (e.g., human) mouth. The object **1302** may include a maxilla bone, a palate bone, a tooth, the mandible, or the tongue. The X-ray is attenuated by different degrees by the different structures of the object **1302** and is projected to the image sensor **9000**. The image sensor **9000** forms an image by detecting the intensity distribution of the X-ray. Teeth absorb X-ray more than dental caries, infections, periodontal ligament. The dosage of X-ray radiation received by a dental patient is typically small (around 0.150 mSv for a full mouth series).

**[0115]** FIG. **14** schematically shows a cargo scanning or non-intrusive inspection (NII) system comprising the image sensor **9000** described herein. The system may be used for inspecting and identifying goods in transportation systems such as shipping containers, vehicles, ships, luggage, etc. The system comprises an X-ray source **1401**. X-ray emitted from the X-ray source **1401** may backscatter from an object **1402** (e.g., shipping containers, vehicles, ships, etc.) and be projected to the image sensor **9000**. Different internal structures of the object **1402** may backscatter X-ray differently. The image sensor **9000** forms an image by detecting the intensity distribution of the backscattered X-ray and/or energies of the backscattered X-ray photons.

**[0116]** FIG. **15** schematically shows another cargo scanning or non-intrusive inspection (NIII) system comprising the image sensor **9000** described herein. The system may be used for luggage screening at public transportation stations and airports. The system comprises an X-ray source **1501**. X-ray emitted from the X-ray source **1501** may penetrate a piece of luggage **1502**, be differently attenuated by the contents of the luggage, and projected to the image sensor **9000**. The image sensor **9000** forms an image by detecting the intensity distribution of the transmitted X-ray. The system may reveal contents of luggage and identify items forbidden on public transportation, such as firearms, narcotics, edged weapons, flammables.

**[0117]** FIG. **16** schematically shows a full-body scanner system comprising the image sensor **9000** described herein. The full-body scanner system may detect objects on a person's body for security screening purposes, without physically removing clothes or making physical contact. The full-body scanner system may be able to detect non-metal objects. The full-body scanner system comprises an X-ray source **1601**. X-ray emitted from the X-ray source **1601** may backscatter from a human **1602** being screened and objects thereon, and be projected to the image sensor **9000**. The objects and the human body may backscatter X-ray differently. The image sensor **9000** forms an image by detecting the intensity distribution of the backscattered X-ray. The image sensor **9000** and the X-ray source **1601** may be configured to scan the human in a linear or rotational direction.

**[0118]** FIG. **17** schematically shows an X-ray computed tomography (X-ray CT) system. The X-ray CT system uses computer-processed X-rays to produce tomographic images (virtual "slices") of specific areas of a scanned object. The

tomographic images may be used for diagnostic and therapeutic purposes in various medical disciplines, or for flaw detection, failure analysis, metrology, assembly analysis and reverse engineering. The X-ray CT system comprises the image sensor **9000** described herein and an X-ray source **1701**. The image sensor **9000** and the X-ray source **1701** may be configured to rotate synchronously along one or more circular or spiral paths.

**[0119]** FIG. **18** schematically shows an electron microscope. The electron microscope comprises an electron source **1801** (also called an electron gun) that is configured to emit electrons. The electron source **1801** may have various emission mechanisms such as thermionic, photocathode, cold emission, or plasmas source. The emitted electrons pass through an electronic optical system **1803**, which may be configured to shape, accelerate, or focus the electrons. The electrons then reach a sample **1802** and an image detector may form an image therefrom. The electron microscope may comprise the image sensor **9000** described herein, for performing energy-dispersive X-ray spectroscopy (EDS). EDS is an analytical technique used for the elemental analysis or chemical characterization of a sample. When the electrons incident on a sample, they cause emission of characteristic X-rays from the sample. The incident electrons may excite an electron in an inner shell of an atom in the sample, ejecting it from the shell while creating an electron hole where the electron was. An electron from an outer, higher-energy shell then fills the hole, and the difference in energy between the higher-energy shell and the lower energy shell may be released in the form of an X-ray. The number and energy of the X-rays emitted from the sample can be measured by the image sensor **9000**.

**[0120]** The image sensor **9000** described here may have other applications such as in an X-ray telescope, X-ray mammography, industrial X-ray defect detection, X-ray microscopy or microradiography, X-ray casting inspection, X-ray non-destructive testing, X-ray weld inspection, X-ray digital subtraction angiography, etc. It may be suitable to use this image sensor **9000** in place of a photographic plate, a photographic film, a PSP plate, an X-ray image intensifier, a scintillator, or another semiconductor X-ray detector.

**[0121]** While various aspects and embodiments have been disclosed herein, other aspects and embodiments will be apparent to those skilled in the art. The various aspects and embodiments disclosed herein are for purposes of illustration and are not intended to be limiting, with the true scope and spirit being indicated by the following claims.

What is claimed is:

1. An image sensor comprising:
  - one or more packages of semiconductor radiation detectors;
  - wherein each of the one or more packages comprises a radiation detector,
  - wherein the radiation detector comprises a radiation absorption layer on a first strip of semiconductor wafer and an electronics layer on a second strip of semiconductor wafer,
  - wherein the radiation absorption layer is continuous along the first strip of semiconductor wafer with no coverage gap,
  - wherein the first strip and the second strip are longitudinally aligned and bonded together;
  - wherein the one or more packages comprise a first group of radiation detectors bonded and electrically con-

nected to a first PCB and a second group of the radiation detectors bonded and electrically connected to a second PCB, wherein the first PCB and the second PCB are bonded and electrically connected to a system PCB.

2. The image sensor of claim 1, wherein the electronics layer comprises transmission lines at a first surface of the second strip of semiconductor wafer bonded to the first strip of semiconductor wafer.

3. The image sensor of claim 2, wherein the electronics layer comprises vias electrically connected to the transmission lines.

4. The image sensor of claim 3, wherein the second strip of semiconductor wafer comprise a redistribution layer (RDL) electrically connected to the vias.

5. The image sensor of claim 2, wherein the radiation absorption layer comprises electrical connections electrically connected to the electrical contacts of the electronics layer.

6. The image sensor of claim 5, wherein the electrical connections comprise doped regions in the first strip of semiconductor wafer.

7. The image sensor of claim 1, wherein the first group of radiation detectors at least partially overlap with the second group of radiation detectors.

8. The image sensor of claim 1, wherein the radiation absorption layer is configured to detect one of electromagnetic radiation including ultraviolet (UV), X-ray, gamma ray.

9. An image sensor comprising:  
 one or more packages of semiconductor radiation detectors;  
 wherein each of the one or more packages comprises a radiation detector,  
 wherein the radiation detector comprises a radiation absorption layer on a first strip of semiconductor wafer and an electronics layer on a second strip of semiconductor wafer,  
 wherein the radiation absorption layer is continuous along the first strip of semiconductor wafer with no coverage gap,  
 wherein the first strip and the second strip are longitudinally aligned and bonded together;  
 wherein the radiation absorption layer is configured to detect one of particle radiation including alpha particles, beta particles and neutron particles.

10. An image sensor comprising:  
 one or more packages of semiconductor radiation detectors;  
 wherein each of the one or more packages comprises a radiation detector;  
 wherein the radiation detector comprises a radiation absorption layer on a first strip of semiconductor wafer and an electronics layer on a second strip of semiconductor wafer;

wherein the radiation absorption layer is continuous along the first strip of semiconductor wafer with no coverage gap;

wherein the first strip and the second strip are longitudinally aligned and bonded together;

wherein the radiation absorption layer comprises an electrode and the electronics layer comprises an electronics system, the electronics system comprises:

a first voltage comparator configured to compare a voltage of the electrode to a first threshold;

a second voltage comparator configured to compare the voltage to a second threshold;

a counter configured to register a number of radiation photons or particles reaching the radiation absorption layer;

a controller;

wherein the controller is configured to start a time delay from a time at which the first voltage comparator determines that an absolute value of the voltage equals or exceeds an absolute value of the first threshold;

wherein the controller is configured to activate the second voltage comparator during the time delay;

wherein the controller is configured to cause the number registered by the counter to increase by one, if the second voltage comparator determines that an absolute value of the voltage equals or exceeds an absolute value of the second threshold.

11. The image sensor of claim 10, wherein the electronics system further comprises a capacitor module electrically connected to the electrode, wherein the capacitor module is configured to collect charge carriers from the electrode.

12. The image sensor of claim 10, wherein the controller is configured to activate the second voltage comparator at a beginning or expiration of the time delay.

13. The image sensor of claim 10, wherein the electronics system further comprises a voltmeter, wherein the controller is configured to cause the voltmeter to measure the voltage upon expiration of the time delay.

14. The image sensor of claim 10, wherein the controller is configured to determine an X-ray photon energy based on a value of the voltage measured upon expiration of the time delay.

15. The image sensor of claim 10, wherein the controller is configured to connect the electrode to an electrical ground.

16. The image sensor of claim 10, wherein a rate of change of the voltage is substantially zero at expiration of the time delay.

17. The image sensor of claim 10, wherein a rate of change of the voltage is substantially non-zero at expiration of the time delay.

18. A system comprising the image sensor of claim 1 and an X-ray source.

\* \* \* \* \*