



US 20060238426A1

(19) **United States**

(12) **Patent Application Publication**
Savage et al.

(10) **Pub. No.: US 2006/0238426 A1**

(43) **Pub. Date: Oct. 26, 2006**

(54) **EMBEDDED ANTENNA APPARATUS FOR UTILITY METERING APPLICATIONS**

(52) **U.S. Cl. 343/702; 343/795; 343/873**

(76) Inventors: **Larry L. Savage**, Central, SC (US);
Kirby K. Nelson III, Seneca, SC (US);
Michael D. Rock, Seneca, SC (US)

(57) **ABSTRACT**

Correspondence Address:
JOHN S. PRATT, ESQ
KILPATRICK STOCKTON, LLP
1100 PEACHTREE STREET
ATLANTA, GA 30309 (US)

A multi-purpose embedded antenna apparatus for facilitating the communication of RF data signals is disclosed. Exemplary embodiments of the subject technology are utilized in a wireless utility metering environment and corresponding nodal network of communications devices. Preferred embedded antenna embodiments incorporate an RF antenna into a structural member, such as a faceplate, of a utility meter. Additional functionality may also be offered through device labeling incorporated with such an antenna apparatus. Exemplary embedded antenna apparatuses in accordance with the present subject matter may comprise a body of dielectric material, a radio frequency (RF) antenna applied to the body of dielectric material in a predefined size and pattern, and a connective element to interface the antenna to a communications module within a utility meter or other electronic device. An antenna apparatus may offer additional structural stability for meter housings. The location and design of the disclosed antenna modules preferably offer improved performance characteristics, including high antenna gain and uniform energy distribution.

(21) Appl. No.: **11/473,931**

(22) Filed: **Jun. 23, 2006**

Related U.S. Application Data

(63) Continuation of application No. 10/985,267, filed on Nov. 10, 2004, which is a continuation of application No. 10/303,673, filed on Nov. 25, 2002, now abandoned.

(60) Provisional application No. 60/333,878, filed on Nov. 26, 2001.

Publication Classification

(51) **Int. Cl.**
H01Q 1/24 (2006.01)

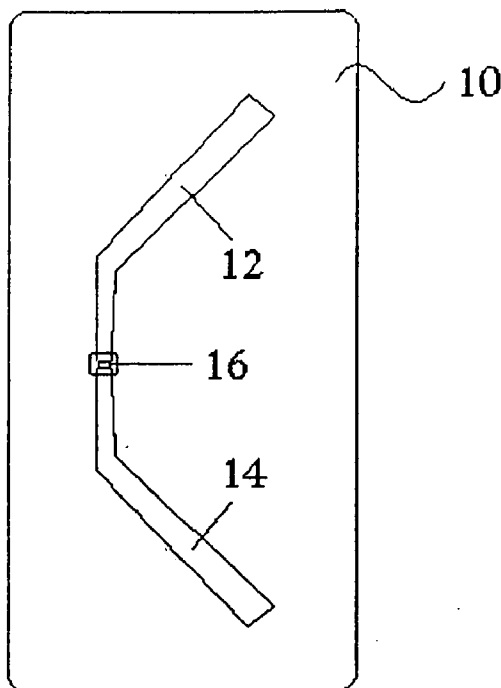

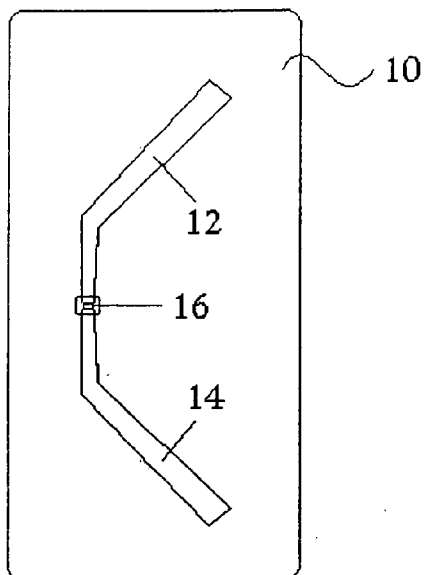

Figure 1A

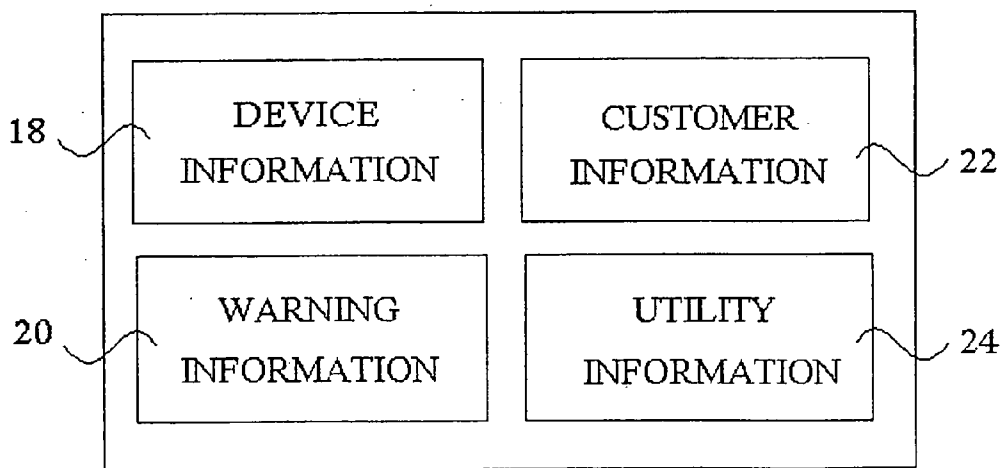

Figure 1B

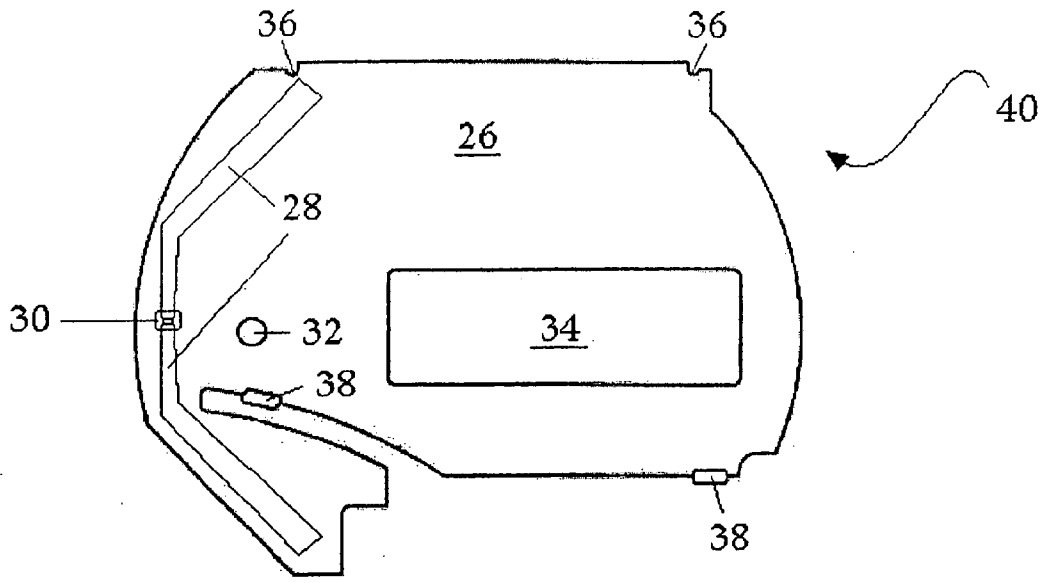

Figure 2A

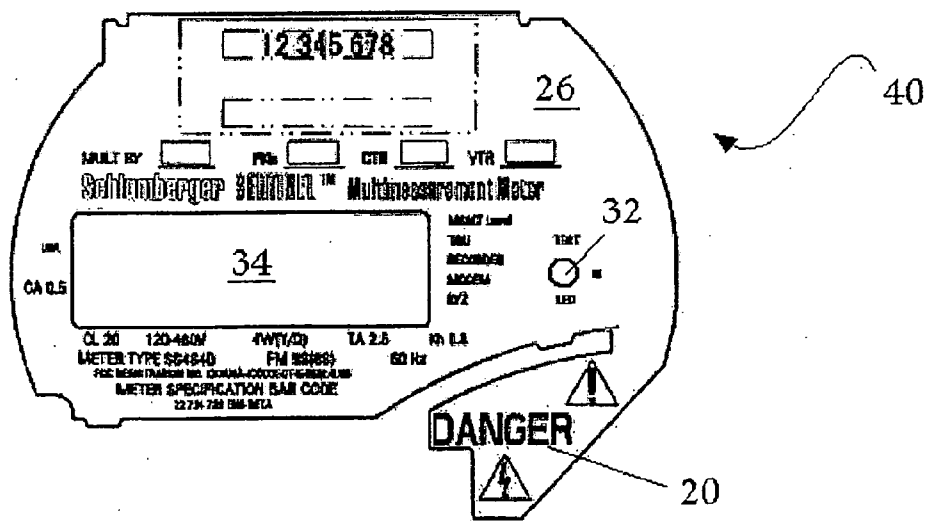

Figure 2B

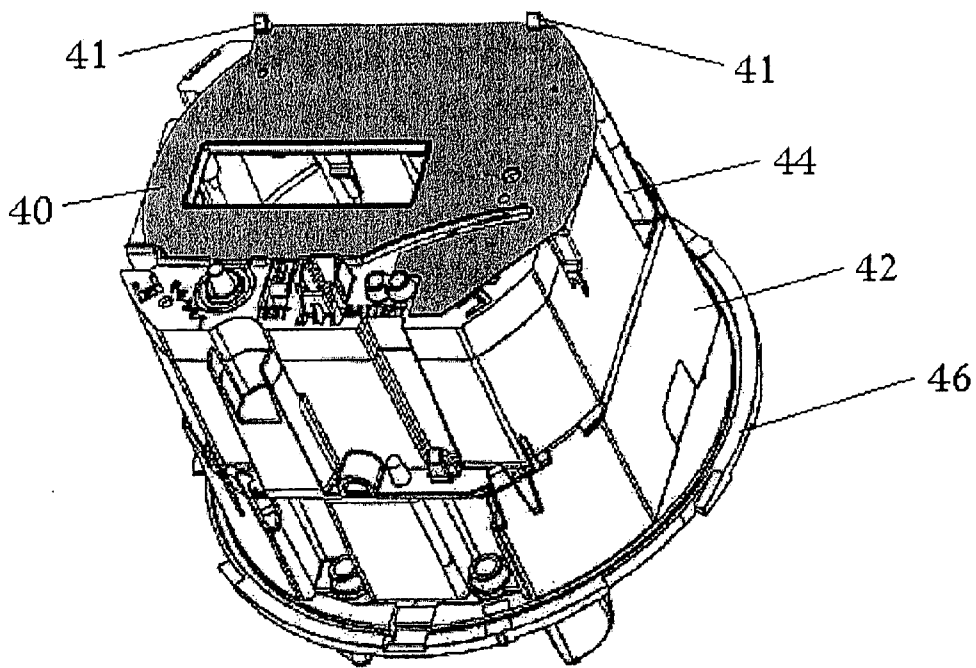

Figure 3A

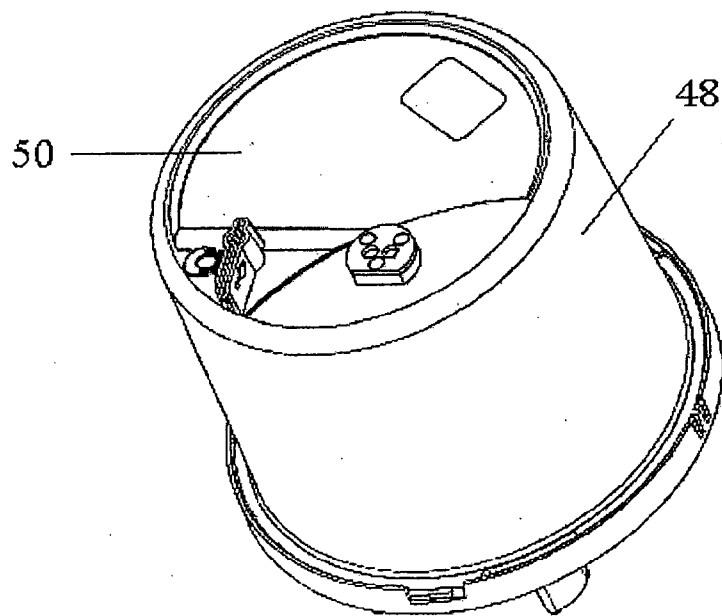

Figure 3B

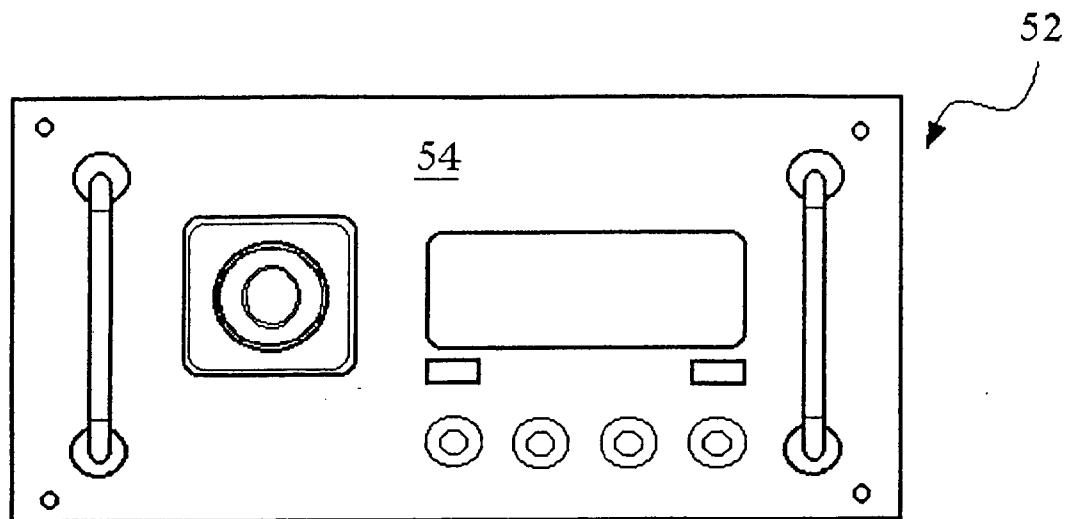

Figure 4A

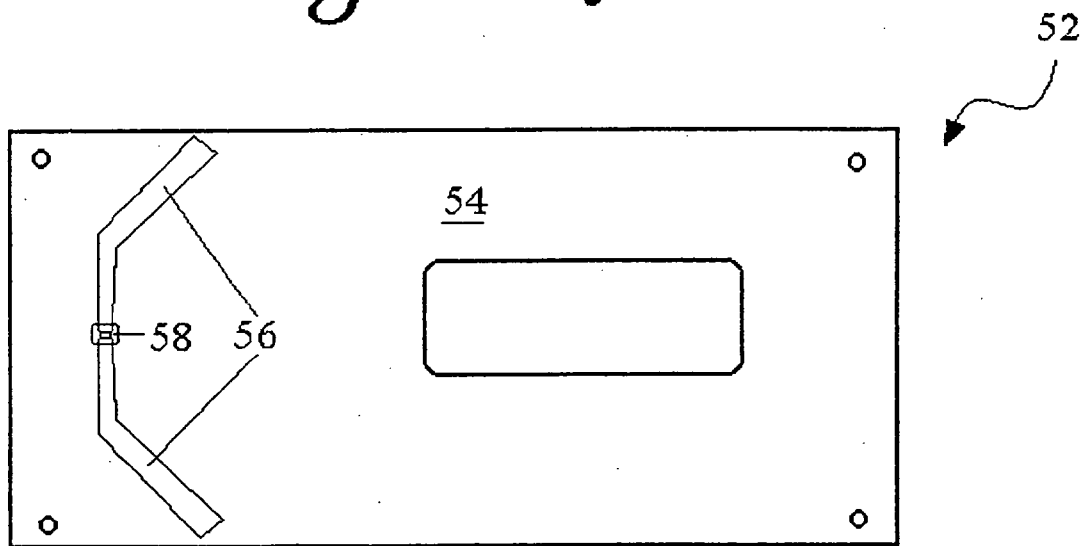

Figure 4B

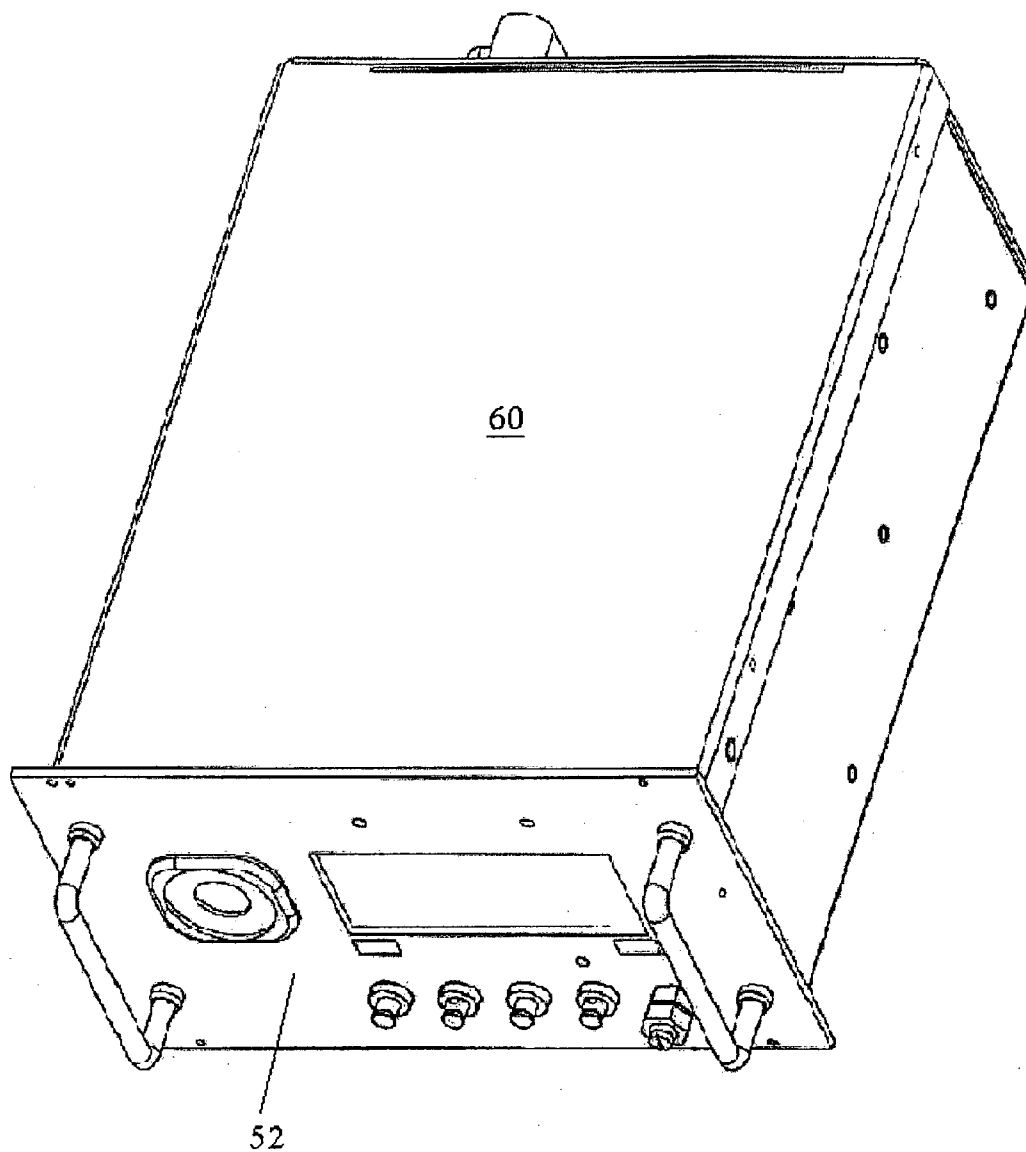

Figure 5

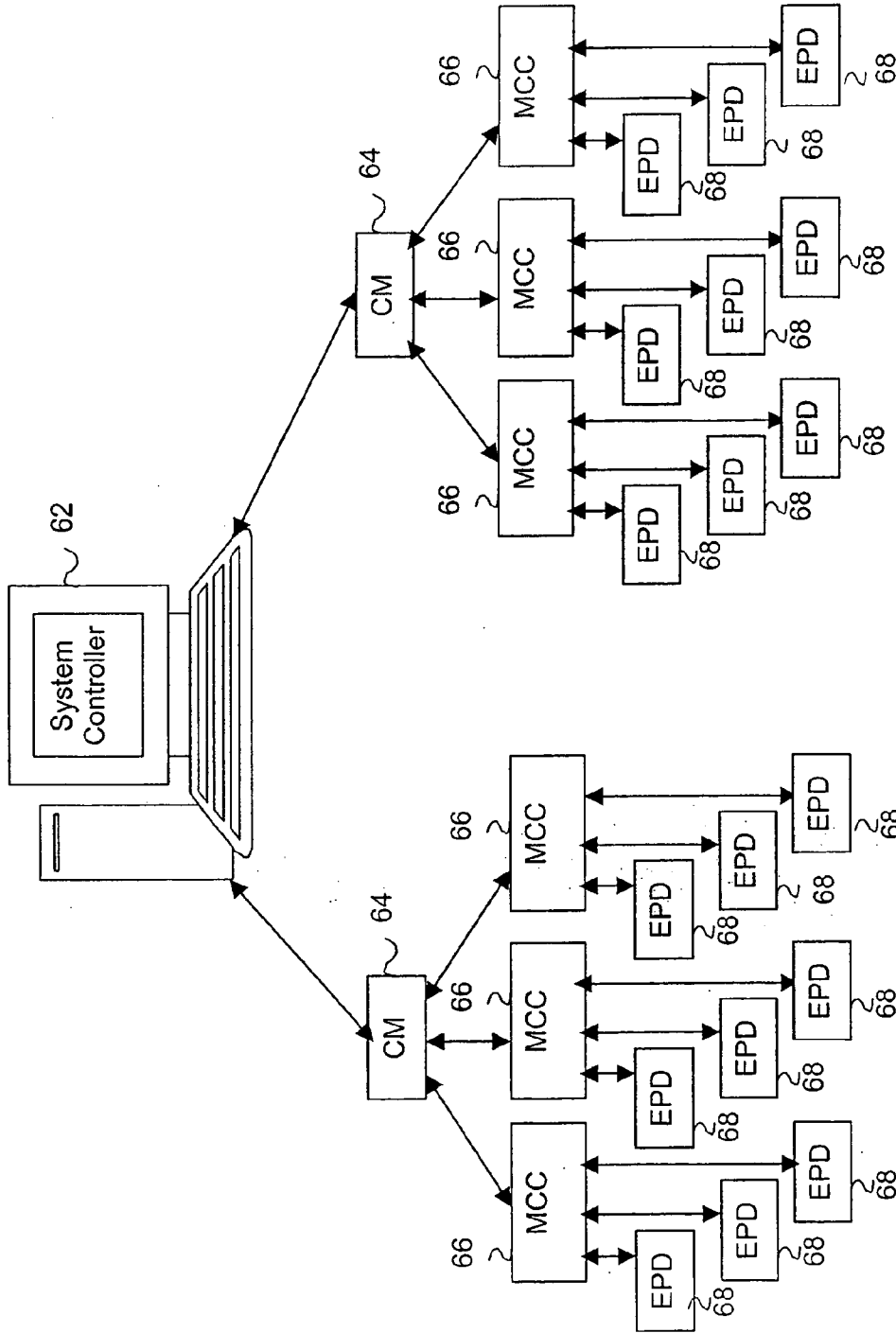

Figure 6

EMBEDDED ANTENNA APPARATUS FOR UTILITY METERING APPLICATIONS

PRIORITY CLAIM

[0001] This application claims the benefit of previously filed U.S. Provisional Patent Application entitled "EMBEDDED ANTENNA APPARATUS FOR UTILITY METERING APPLICATIONS" with the same inventors as present, assigned U.S. Ser. No. 60/333,878, filed on Nov. 26, 2001, and which is incorporated herein by reference.

BACKGROUND OF THE INVENTION

[0002] The present subject matter generally concerns an embedded antenna for use in electronic devices that transmit or receive data signals in a wireless communications environment. More particularly, the subject embedded antenna may be used to facilitate communication associated with utility metering among endpoints and other nodes in a wireless utility network. In some exemplary embodiments of the presently disclosed technology, an embedded antenna is incorporated into a structural member of a utility meter. Such a modular embedded antenna apparatus can provide a plurality of functions, including radio frequency (RF) reception and radiation, device labeling, and structural support for a utility meter.

[0003] Several types of customer utilities are available at residential and commercial properties worldwide. Such properties and other locations may typically be provided with selected utilities (i.e., products or commodities) such as water, gas, electricity, cable service, telecommunications, and others. When a selected utility is provided to a customer load, there is typically some sort of metering hardware that is available for monitoring the amount of product or service that is provided to a specific customer load. Utility meters are typically characterized by some sort of metrology hardware that measures this consumption information and other related variables.

[0004] Many utility meters also include communications elements that provide a signal interface between the metrology hardware of a meter and other devices. Known communications components in some utility meters include radio frequency (RF) communications devices that can transmit and receive signaled information between the meter and communications nodes at other locations in a metering network. A meter with such wireless communication capabilities may provide an arrangement for remotely reading consumption data and other information from the meter without having to manually retrieve this information from a meter.

[0005] Remote data acquisition is only one of many potential applications that becomes possible due to the development of wireless metering technology. General monitoring and remote control of meters and other distribution system points in a utility network may also be available. With the appropriate interface among metering system components, wireless services may include remote sensing for sectionalized circuits, fault location and isolation, and detection of impending system failure. Wireless technology associated with the present subject matter may also contribute to commercial information opportunities such as office machine monitoring, home energy management, vending machine monitoring, or security and smoke detection.

[0006] RF antennas have typically been incorporated with communications hardware associated with metering or monitoring devices. Just as with the location of other utility meter elements, antenna location may be restricted to the confines of a meter's "black box," typically defined by a meter's outer cover. Antennas enclosed within a product's housing or outer casing are often referred to as embedded antennas. Restricted location may also be due to packaging and performance constraints, or to stave off the possibility of meter tampering in the field.

[0007] Known utility meters include communications modules within the meter structure, such that an antenna may often be located on a circuit board or other internal location. An antenna embedded deep within a metering device may be subjected to interference from other electronic components, thus hindering performance characteristics of the antenna. Other known antennas associated with metering devices may be adhered to the outside cover of a utility meter. This option poses potential problems because it is often hard to repeatedly position such an antenna for optimal antenna radiation. Environmental exposure of an antenna adhered to the exterior of a metering device may also cause the antenna adhesive to fail, posing the risk of completely losing antenna functionality.

[0008] A specific example of a communications module and associated antenna for use in a utility meter environment is disclosed in U.S. Patent Application Publication No. US 2001/0038343 A1 (Meyer et al.) Meyer et al. discloses an exemplary double-tapered dipole antenna for internal mounting within a communications module associated with a utility meter. The internal antenna is not designed with a specific optimized location, and thus an external antenna may often be required. Furthermore, the lack of design location for such antenna components still yields a potential for interference among other components of the communications module and associated utility meter.

[0009] There are other criteria that may influence antenna design. The antenna must preferably be positioned such that its ability to radiate and receive wireless signals is optimized. Optimal performance may be of particular importance with metering applications, due to possible obscure meter location, such as in a basement or other lower structural level. Optimized antenna performance may also provide a wider range of communications capabilities within a wireless network.

[0010] It is thus desired to provide antenna designs and related features that offer preferred location and optimized performance characteristics. It may also be preferred to incorporate such features as labeling information, structural support, and antenna functionality in a single modular antenna apparatus. While various aspects and alternative embodiments may be known in the field of embedded antenna technology, no one design has emerged that generally encompasses the above-referenced characteristics and other desirable features associated with antenna technology and related wireless metering applications.

BRIEF SUMMARY OF THE INVENTION

[0011] The present subject matter recognizes and addresses various of the foregoing shortcomings, and others concerning certain aspects of embedded antenna technology. Thus, broadly speaking, a principal object of the presently

disclosed technology is improved antenna location and performance. More particularly, the disclosed antenna technology preferably facilitates the transmission and receipt of utility information in a wireless metering network.

[0012] It is another principal object of the disclosed technology to provide an embedded RF antenna with optimized location to comply with industry standards and packaging constraints. Location of the subject embedded antenna also preferably provides optimized performance characteristics, including antenna gain and energy distribution. It is preferred that the antenna location is easily and consistently repeatable, yielding reliable optimized performance.

[0013] Yet another principal object of selected embodiments of the present subject matter is to provide an embedded antenna apparatus that serves multiple purposes. An antenna apparatus associated with utility metering may preferably provide improved RF antenna functionality, meter device labeling, and structural support for the associated device. Embodiments of the subject technology that incorporate multiple meter features into a single modular apparatus preferably reduce part count, assembly time, and cost associated with production of the antenna apparatus.

[0014] It is a general object of selected embodiments of the subject embedded antenna technology to provide an embedded antenna module that does not require incorporation with or attachment to a meter by way of adhesives or loose connective parts, such as screws, clips, or other fasteners, that may be easily lost or misplaced in the field.

[0015] Another general object of selected embodiments of the disclosed technology is to provide an antenna that facilitates remote monitoring, controlling, and communication among meters and other distribution points in a customer utility network. Customer utilities may include services, products or commodities associated with gas, water, electricity, cable service, telecommunications, and others.

[0016] Yet another object of the disclosed technology is to provide an embedded antenna design that incorporates selected of the aforementioned preferred antenna features into a design that is cost effective, efficient, and reliable.

[0017] Additional objects and advantages of the present subject matter are set forth in, or will be apparent to those of ordinary skill in the art from, the detailed description herein. Also, it should be further appreciated by those of ordinary skill in the art that modifications and variations to the specifically illustrated, referenced, and discussed features and components hereof may be practiced in various embodiments and uses of this invention without departing from the spirit and scope thereof, by virtue of present reference thereto. Such variations may include, but are not limited to, substitution of equivalent means and features, or materials for those shown, referenced, or discussed, and the functional, operational, or positional reversal of various parts, features, or the like.

[0018] Still further, it is to be understood that different embodiments, as well as different presently preferred embodiments, of this invention may include various combinations or configurations of presently disclosed features or elements, or their equivalents (including combinations of features or configurations thereof not expressly shown in the figures or stated in the detailed description). A first exemplary embodiment of the present subject matter relates to a

meter faceplate for positioning relative to an external surface of a utility meter. Such a meter faceplate may include a body of dielectric material, a patterned radio frequency (RF) antenna, and an electrical connection. The body of dielectric material preferably provides an integral portion of a utility meter and is characterized by inner and outer surfaces thereof. The patterned RF antenna is formed on the inner surface of the body of dielectric material and is configured to transmit and receive RF signals associated with a communications module of the utility meter. The electrical connection is then between such communications module and the RF antenna. The patterned RF antenna may correspond to layers of foil metallization which may be configured, for example, in two generally symmetrical portions extending from the base electrical connection to form a dipole antenna.

[0019] Another exemplary embodiment of the presently disclosed technology corresponds to an electronic device with an embedded antenna apparatus for radiating and receiving RF signals. The electronic device preferably includes a communications module configured to process and relay the RF signals. A dielectric substrate forms a casing component for the electronic device and at least one portion of metallization may be formed on the dielectric substrate for forming a functional antenna element for the electronic device. A connective element connects the metallization portion(s) to the communications module.

[0020] Yet another exemplary embodiment of the present subject matter corresponds to a utility meter for monitoring or controlling the distribution of a utility product or service to a customer, such as but not limited to water, gas, electricity, cable, or telecommunications. The utility meter preferably includes at least one housing component, a faceplate, and a patterned RF antenna. The at least one housing component protects selected electronics and other internal components of the utility meter, while the faceplate may be attached to the front of the housing component. The patterned RF antenna is formed on a selected surface of the faceplate and is configured to transmit and receive RF signals from a communications module associated with the utility meter. The RF antenna may be positioned within the utility meter such that its primary plane of polarization is substantially vertical, and the antenna may relay RF signals at selected frequencies in a range from 900 MHz to 3 MHz.

[0021] Additional exemplary embodiments of the subject embedded antenna technology may comprise selected of the aforementioned embodiments in combination with additional features or parts. One particular such embodiment may incorporate functional labeling onto the body of dielectric material or structural member. Functional labeling may preferably provide detailed information to a customer concerning product specifications or potential hazard warnings. In a utility meter environment, the labeling may offer information about the utility, the meter, the customer, and necessary warning information. This labeling information may be provided by a variety of conventional application methods.

[0022] Additional embodiments of the present subject matter, not necessarily expressed in this summarized section, may include and incorporate various combinations of aspects of features or parts referenced in the summarized objectives above, and/or features or parts as otherwise discussed in this application.

[0023] Those of ordinary skill in the art will better appreciate the features and aspects of such embodiments, and others, upon review of the remainder of the specification.

BRIEF DESCRIPTION OF THE DRAWINGS

[0024] A full and enabling description of the presently disclosed technology, including the best mode thereof, directed to one of ordinary skill in the art, is set forth in the specification, which makes reference to the appended figures, in which:

[0025] **FIG. 1A** illustrates an exemplary embedded antenna module for use in selected electronic devices in accordance with the present subject matter;

[0026] **FIG. 1B** displays exemplary information options for incorporating with device labeling functionality in accordance with the presently disclosed technology;

[0027] **FIGS. 2A and 2B** correspond to an exemplary embodiment of an embedded antenna apparatus in accordance with the present subject matter, wherein **FIG. 2A** provides a generally rear view of the exemplary embodiment, and wherein **FIG. 2B** provides a generally front view of the exemplary embodiment;

[0028] **FIG. 3A** illustrates an exemplary utility meter, featuring an embedded antenna apparatus in accordance with the disclosed technology combined with other internal structural members, providing an inner housing for the electronics and other internal components of such a utility meter;

[0029] **FIG. 3B** illustrates an exemplary utility meter such as that illustrated in **FIG. 3A**, featuring an outer cover for enclosing all internal mechanical structures and electronic components associated with such a utility meter;

[0030] **FIGS. 4A and 4B** correspond to a further exemplary embodiment of an embedded antenna apparatus in accordance with the present subject matter, wherein **FIG. 4A** provides a generally front view of the exemplary embodiment, and wherein **FIG. 4B** provides a generally rear view of the exemplary embodiment;

[0031] **FIG. 5** illustrates a further exemplary utility meter, featuring an embedded antenna apparatus in accordance with the disclosed technology combined with other structural members for providing a comprehensive housing for the electronics and other internal components of such a utility meter; and

[0032] **FIG. 6** is a block diagram of an exemplary communications network as utilized in conjunction with the receipt and radiation of RF signals in accordance with the subject embedded antenna technology.

[0033] Repeat use of reference characters throughout the present specification and appended drawings is intended to represent same or analogous features or elements of the invention.

DETAILED DESCRIPTION OF THE DRAWINGS

[0034] As referenced in the Brief Summary of the Invention section, the present subject matter is directed towards an embedded antenna for use in electronic devices that transmit or receive data signals in a wireless communications environment. More particularly, the subject embedded antenna

may be used to facilitate communication associated with utility metering among endpoints and other nodes in a wireless utility network.

[0035] There are several functional features presented herein that may be incorporated into exemplary embodiments of the subject technology. A necessary functional feature of all embodiments of the subject technology is an RF antenna used to radiate and/or receive remote signals associated with the exemplary device. Another functional feature relates to the incorporation of an embedded antenna into a casing feature or structural member of an exemplary electronic device. Yet another functional feature associated with selected embodiments of the present subject matter relates to the labeling of important information associated with an exemplary device. Several exemplary embodiments presented herein correspond to modular embedded antenna apparatuses that provide a plurality of functions, including radio frequency (RF) reception and radiation, device labeling, and structural support for a utility meter. However, it should be appreciated that other embodiments of the subject technology may include variations of respective such features as well as varied combinations of such functional features. It should also be appreciated that such combinations may be utilized in a utility metering environment as well as in other environments utilizing some form of wireless communications without departing from the scope of the present technology.

[0036] General exemplary embodiments of the subject embedded antenna modules are first presented in accordance with **FIGS. 1A and 1B**. Additional exemplary embodiments of an embedded antenna apparatus are presented in **FIGS. 2A, 2B, 4A, and 4B**. Exemplary utility meters with embedded antenna apparatuses in accordance with the subject technology are displayed in **FIGS. 3A, 3B, and 5**, and discussed with further detail herein. **FIG. 6** presents an exemplary nodal communications network as a potential environment for utilization of aspects of the disclosed antenna technology and related antenna performance capabilities.

[0037] It should be noted that each of the exemplary embodiments presented and discussed herein should not insinuate limitations of the present subject matter. Features illustrated or described as part of one embodiment may be used in combination with aspects of another embodiment to yield yet further embodiments. Additionally, certain features may be interchanged with similar devices or features not expressly mentioned which perform the same or similar function.

[0038] Reference will now be made in detail to the presently preferred embodiments of the subject embedded antenna technology. Referring now to the drawings, **FIGS. 1A and 1B** generally display aspects of functional features that may be incorporated into selected embodiments of the present technology. A first functional feature is the provision of an antenna module that facilitates the receipt and radiation of RF signals associated with a given electronic device. An example of such an antenna feature is displayed in **FIG. 1A**, in which a metallic foil antenna embodied by portions **12, 14, and 16** is formed on a substrate **10**. This exemplary metallic foil antenna is a dipole antenna formed by two symmetrical portions **12 and 14**, and joined by a connective element **16**. More specific details relating to the formation

and associated performance of such an antenna will be presented with reference to additional figures. This type of antenna may be employed with any type of wireless application, including wireless metering.

[0039] Since it is preferred that the antenna foil pattern **12** and **14** be applied to a dielectric material constituting the substrate **10**, it may also be preferred to include on the dielectric material a label or etching that provides certain selected information to a user. Types of information that might be included within an exemplary module of the present subject matter are presented in **FIG. 1B**. Device information **18** may be presented to provide particular operating specifications for the electronic device that the antenna is used in conjunction with. Warning information **20** may be provided to convey any risks or hazards associated with use or misuse of the subject electronic device. Customer information **22** may be provided when the identification of a customer offers some particular function, such as in customer utility applications. In an environment such as utility metering, device information **18** may then correspond to particular information about the associated metering device. In such an environment, selected utility information **24** may also be provided in accordance with appropriate device labeling functionality.

[0040] A particular exemplary embodiment of the subject embedded antenna technology in a utility metering environment is illustrated in **FIGS. 2A and 2B**. The metering environment may correspond to the distribution of customer utility products such as water, electricity, gas, cable, telecommunications, and others. This exemplary embodiment **40** preferably combines functional features such as RF antenna operation, device labeling, and structural support into a single modular apparatus. **FIG. 2A** illustrates a generally rear view of exemplary embodiment **40**, and **FIG. 2B** illustrates a generally front view. It should hereafter be understood that a generally front view corresponds to a view facing towards a meter and corresponding components when the meter is attached to a wall or other fixed surface. The wall or fixed surface extends in a generally vertical fashion above the ground such that a mounted meter face is generally parallel to the fixed surface, and thus also oriented in a generally vertical fashion.

[0041] Embedded antenna apparatus **40** is preferably incorporated into a utility meter such as in **FIG. 3A**. Embodiment **40** thus provides a sort of internal faceplate for the meter. A first internal housing component **42** preferably attaches to baseplate **46** and offers protection for selected electronics and other internal components of a meter. Additional internal components are preferably protected by a second housing component **44**, which attaches to the first housing component **42** and offers additional internal structural stability to the meter. Antenna module **40** preferably attaches to the front of the second inner housing **44**. In preferred embodiments of the subject matter, antenna module **40** snaps into the inner cover **44** and is secured without the need for additional adhesive or loose fasteners such as clips, screws, or the like.

[0042] Module **40** preferably includes at least one male connector and at least one female connector for attaching module **40** to inner casing **44**. In the exemplary embodiments displayed in **FIGS. 2A, 2B, and 3A**, tabs **38** preferably extend from the rear of apparatus **40** and fit into slots

provided at the front of inner casing **44**. Ridges **36** may also preferably be formed into apparatus **40** such that connective extensions **41** can be snapped over module **40** to fasten the apparatus in a secure yet removable fashion. Once the antenna apparatus **40** is fit and snapped into place, it may preferably offer additional support to the overall meter structure. It is desirable in some embodiments of the present technology to have such a specific method and location for fastening module **40** such that an associated antenna is in a fixed location, thus offering consistent and repeatable performance characteristics.

[0043] Once the embedded antenna module is secured with the other internal meter components, such as in **FIG. 3A**, an outer cover **48** is preferably fitted over the internal components such as in **FIG. 3B**. Outer cover **48** preferably has a transparent front panel **50** such that any labeling or display functions of the meter are clearly visible. Antenna apparatus **40** is thus at an ideal location at the front of an enclosed meter. This is a relatively unencumbered location very near the periphery of the device, thus providing a very preferable location for optimum antenna functionality.

[0044] Now referring again to **FIG. 2A**, portion **26** of exemplary antenna apparatus **40** comprises a dielectric substrate formed in a shape that may be generally similar to but slightly smaller than the front faceplate portion of a meter. An example of the type of dielectric material used to form substrate **26** is a fiberglass epoxy material such as FR4. A nonconductive material may preferably be chosen such that the potential for antenna interference is minimized and the antenna's radiation capabilities are maximized.

[0045] The substrate **26** may include a plurality of openings such that other components, specifically display features associated with a utility meter, may be visible at the front of the meter. A generally rectangular opening **34** is preferably provided for visual access to a segmented LCD display that provides typical metering consumption information and other displayed output relative to meter operation. A smaller circular opening **32** may preferably be provided for visual access to an LED that provides output such as consumption rate, KYZ output, or other associated variables.

[0046] The embedded antenna feature of the present subject matter is then formed onto a selected location on the rear of substrate **26**. The antenna feature preferably corresponds to a metallic foil pattern **28** that is appropriately shaped to form a radio frequency antenna. The metallic foil pattern **28** may be adhered to, etched onto, or inked onto the substrate in accordance with known techniques. Examples of the metallization used to form foil antenna **28** include copper, palladium, silver, an alloy formed by combining selected of the above metals, or other appropriate conductive substances. Once the metallization pattern **28** is formed onto substrate **26**, another layer of dielectric material may then optionally be applied over the antenna such that it is encapsulated and protected within a dielectric body.

[0047] The antenna shape and dimension is preferably chosen to optimize radiation characteristics. Appropriate antenna patterns may, for example, correspond to the formation of patch, slot or dipole antenna configurations. The exemplary antenna **28** of **FIG. 2A** corresponds to a half-wave slanted dipole configuration with optimal shape and corresponding dimensions. Once the associated utility meter

is mounted to its vertical location, the antenna is oriented in a final position such that its primary plane of polarization is generally vertical. A connector **30** is provided at the base junction of the dipole antenna arms, to which an appropriate interface is provided to form an electrical connection from the antenna **28** to an RF communications module within the meter. Such a communications module may correspond to an RF transmitter and/or receiver that relays selected information associated with the meter.

[0048] Although the electrical interface between the antenna and a communications module is not specifically shown in the drawings, it should be appreciated that this conductive wire extension may also be incorporated into exemplary embodiments of an embedded antenna apparatus.

[0049] RF antenna **28** is preferably characterized by optimal performance characteristics. Exemplary antenna embodiments provide isotropic antenna gain of generally greater than about 2 dBi. Such exemplary embodiments may also be characterized by a return loss of better than -10 dB at about 917 MHz, and a bandwidth generally greater than about 8 percent with the -10 dB return loss bandwidth. Antenna radiation associated with the exemplary antenna configuration of **FIG. 2A** is such that a generally uniform, cardioidal radiation pattern is effected. The main radiation lobe is preferably in the direction of the front face of the meter (or other electronic device) with an associated peak elevation level generally between 0 and 45 degrees.

[0050] Another functional feature that may be incorporated with antenna apparatus **40** is the provision of device labeling, such as shown in **FIG. 2B**. Labeled information corresponding to a utility meter (especially an electric utility meter) may include such elements as utility name, bar code, customer number, meter serial number, meter class, service type, operating voltage range, socket type, meter form, recorder type, or other information specific to a customer, the utility, or meter and associated manufacturer. Another important type of information that may be displayed via the antenna apparatus is information **24** relating to potential hazards or danger associated with the device. For example, **FIG. 2B** displays a "DANGER" label and two icons representative of a general hazard and a shock hazard, respectively. Labeled information may preferably be placed onto substrate **26** by a separate stick-on label adhered to the substrate. Alternatively, the information may be directly inked onto or etched into the dielectric substrate **26**. By choosing the same method to form the metal foil antenna pattern as to form the labeled information, production time and cost associated with exemplary antenna module embodiments may be reduced.

[0051] Another exemplary embodiment of an embedded antenna apparatus in accordance with the disclosed technology and in the context of a utility metering environment is represented in **FIGS. 4A, 4B** and **5**. **FIGS. 4A** and **4B** display an exemplary meter faceplate **52** that is preferably used in combination with other casing features **60** (such as in **FIG. 5**) to form an outer cover for a utility meter or other electronic device. The meter faceplate preferably comprises a dielectric material with an appropriate thickness such that sufficient strength and protection is provided for internal meter components while ensuring that optimal antenna radiation is attained. As displayed in **FIG. 4A**, additional features may also be incorporated into the antenna apparatus,

such as internal active components, buttons to interface with internal meter features, etc. RF antenna pattern **56** is preferably positioned and applied to the rear side of the module **52**, similar to the method described in reference to **FIG. 2A**.

[0052] The subject RF antenna is an integral aspect of the wireless communications capabilities of a utility meter or other electronic device to which the antenna is interfaced. A meter or other device with RF receiver and/or transmitter functionality may often be referred to as an endpoint in a nodal wireless network. An exemplary representation of a nodal network that may be utilized in accordance with RF communications in a utility network is presented in **FIG. 6**. This communications system is presented merely as an example of the type of environment that the RF antenna might operate in, and should in no way limit the potential for other realms of antenna utilization.

[0053] In the exemplary communications network of **FIG. 6**, system controller **62** controls and communicates with a plurality of cell masters (CMs) **64**, which in turn communicate with a plurality of micro cell controllers (MCCs) **66**, which in turn communicate with a plurality of end-point devices (EPDs) **68**. In a utility environment, each EPD **68** preferably monitors and controls the distribution of some utility product or service, such as electricity, gas, water, cable, telecommunication, etc. Consumption data is determined by basic metrology circuitry associated with the end-point device, and an MCC **66** then preferably collects and manages this consumption data from hundreds of end-points. Communication among MCCs **66** and EPDs **68** may typically correspond to relatively low power spread spectrum radio communication within a local area network. Exemplary frequencies of operation for this one-or two-way communication may be anywhere from about 900 MHz to about 3 GHz, wherein an actual specific frequency range of operation is chosen that complies with FCC regulations and specific system constraints.

[0054] An MCC **66** may then preferably forward selected consumption data and other information to a cellmaster **64** by means of a wireless wide area network. A cellmaster **64** may also communicate with other remote devices in a wireless utility network such as voltage regulators, capacitor bank controllers, line reclosers, sectionalizers, or other electronic devices that are interfaced with the wireless network via remote radio modules. A system controller **62** then preferably corresponds to the central node in a communications network and essentially controls the operation of all other networked components in a utility system.

[0055] The number of devices **64, 66,** and **68** that are displayed in **FIG. 6** is only presented as an example. In actuality, there may preferably be many more nodal components in the network. For instance, the total number of EPDs **68** in the system may typically correspond to the number of utility meters (e.g., thousands) in a designated service area. MCCs **66** and CMs **64** are preferably positioned within a given proximity to a certain number of EPDs to facilitate the communication chain among components. The antenna apparatus of the present subject matter is preferably capable of incorporation with any of the nodal components in a communications network. The subject matter should not be limited to use with a meter or other end-point-device.

[0056] The actual communication among system components is preferably by way of wireless radio frequency (RF) signals. However, even in such “wireless” embodiments, portions of the communications line among system components need not also be wireless. It should be appreciated that other forms of communications links may be utilized in accordance with the subject technology, such as leased lines, wireless modems, or hard-wired networks of coaxial cable, optical fiber, or other transmission media. Each node is preferably capable of two-way communication, and thus able to both transmit and receive signaled information from other communication nodes in the utility network. Transmitted signals may correspond to such information as consumption data and end-point status. Received signals may include information such as instructions for operation.

[0057] While the present subject matter has been described in detail with respect to specific embodiments thereof, it will be appreciated that those skilled in the art, upon attaining an understanding of the foregoing may readily produce alterations to, variations of, and equivalents to such embodiments. Accordingly, the scope of the present disclosure is by way of example rather than by way of limitation, and the subject disclosure does not preclude inclusion of such modifications, variations and/or additions to the present subject matter as would be readily apparent to one of ordinary skill in the art.

What is claimed is:

1. An antenna apparatus for embedded positioning relative to an external surface of a utility meter having a communications module, said antenna apparatus comprising:

a body of dielectric material for providing an integral structural portion of the utility meter, said body of dielectric material characterized by respective inner and outer surfaces relative to the utility meter;

a patterned radio frequency (RF) antenna formed on the inner surface of said body of dielectric material, said patterned RF antenna configured to transmit and receive RF signals associated with a communications module of the utility meter; and

an electrical connection formed with said patterned RF antenna for association with the communications module of a utility meter.

2. An embedded antenna apparatus as in claim 1, wherein said patterned RF antenna comprises first and second conductive portions configured to collectively function as a dipole antenna.

3. An embedded antenna apparatus as in claim 2, wherein said first and second conductive portions respectively extend across said body of dielectric material in a tapered fashion with wider end portions tapering inward towards a base junction for said electrical connection.

4. An embedded antenna apparatus as in claim 1, wherein said RF signals are at selected frequencies in a range from about 900 MHz to about 3 GHz.

5. An embedded antenna apparatus as in claim 1, wherein said body of dielectric material is formed to define at least one opening therethrough.

6. An embedded antenna apparatus as in claim 5, wherein said at least one opening defined by said body of dielectric material accommodates visual access to an output display for relaying meter consumption information.

7. An embedded antenna apparatus as in claim 1, further comprising labeled information on said outer surface of said body of dielectric material, wherein selected of said labeled information is visible from the exterior of the utility meter.

8. An embedded antenna apparatus as in claim 7, wherein said labeled information corresponds to information selected from the group consisting of the utility name, bar code, customer number, meter serial number, meter class, service type, operating voltage range, socket type, meter form, recorder type, and hazard information.

9. An embedded antenna apparatus as in claim 1, wherein said patterned RF antenna is positioned such that its primary plane of polarization is in a substantially vertical direction whenever the utility meter is mounted to a surface that is substantially perpendicular with respect to a ground surface.

10. An embedded antenna apparatus as in claim 1, further comprising an encasing portion of dielectric material applied adjacent to said patterned RF antenna and said body of dielectric material such that said body of dielectric material and said encasing portion of dielectric material encapsulate and protect said patterned RF antenna within a dielectric body.

11. An embedded antenna apparatus as in claim 1, wherein said body of dielectric material comprises a meter faceplate for the utility meter.

12. An electronic device with radio frequency (RF) communication components integrated therein for achieving improved RF communication capabilities, said electronic device comprising:

an RF communications module configured to process and relay data signals transmitted and received by said electronic device;

a dielectric substrate forming a casing component for said electronic device;

at least one predefined portion of metallization layered on said dielectric substrate, said at least one predefined portion of metallization forming a functional antenna element for said RF communications module; and

a connective element connected to said at least one predefined portion of metallization for providing an electrical connection between said functional antenna element and said RF communications module.

13. An electronic device as in claim 12, wherein said data signals transmitted and received by said electronic device comprise utility metering information for a customer utility product selected from the group consisting of water, gas, electricity, cable, and telecommunications.

14. An electronic device as in claim 12, further comprising another predefined portion of metallization layered on said dielectric substrate such that first and second portions of metallization collectively form a dipole antenna for radiating and receiving signals associated with said RF communications module.

15. An electronic device as in claim 14, wherein said first and second portions of metallization forming said dipole antenna respectively extend across said dielectric substrate in a tapered fashion with wider end portions tapering inwards toward said connective element.

16. An electronic device as in claim 12, wherein said functional antenna element transmits and receives signals at selected frequencies in a range from about 900 MHz to about 3 GHz.

17. An electronic device as in claim 12, wherein said functional antenna element is configured for positioning such that its primary plane of polarization is in a substantially vertical direction.

18. An electronic device as in claim 12, further comprising an encasing portion of dielectric material applied adjacent to said at least one predefined portion of metallization and said dielectric substrate such that said dielectric substrate and said encasing portion of dielectric material encapsulate and protect said at least one predefined portion of metallization within a dielectric body.

19. A utility meter for monitoring or controlling the distribution of a utility product or service to a customer, said utility meter comprising:

at least one housing component for protecting selected electronics and other internal components of a utility meter;

a faceplate attached to the front of said at least one internal housing component, said faceplate characterized by an inner and an outer surface thereof; and

a patterned radio frequency (RF) antenna formed on a selected surface of said faceplate, said patterned RF antenna configured to transmit and receive RF signals from a communications module associated with said utility meter.

20. A utility meter as in claim 18, wherein said patterned RF antenna comprises a dipole antenna.

21. A utility meter as in claim 19, wherein said patterned RF antenna transmits and receives RF signals at selected frequencies in a range from about 900 MHz to about 3 GHz.

22. A utility meter as in claim 19, wherein said faceplate is formed to define at least one opening therethrough.

23. A utility meter as in claim 22, wherein said at least one opening defined by said body of dielectric material accommodates visual access to an output display for relaying meter consumption information.

24. A utility meter as in claim 22, wherein said at least one opening defined by said body of dielectric material is configured for interconnecting with mating features on the front of said at least one housing component.

25. A utility meter as in claim 19, further comprising labeled information on said outer surface of said faceplate, wherein selected of said labeled information is visible from the exterior of said utility meter.

26. A utility meter as in claim 25, wherein said labeled information corresponds to information selected from the group consisting of the utility name, bar code, customer number, meter serial number, meter class, service type, operating voltage range, socket type, meter form, recorder type, and hazard information.

27. A utility meter as in claim 19, further comprising an outer cover for encasing said at least one housing component, said faceplate and said patterned RF antenna.

28. A utility meter as in claim 27, further comprising labeled information on said outer surface of said faceplate, wherein selected of said labeled information is visible through said outer cover from the exterior of said utility meter.

29. A utility meter as in claim 28, wherein said labeled information corresponds to information selected from the group consisting of the utility name, bar code, customer number, meter serial number, meter class, service type, operating voltage range, socket type, meter form, recorder type, and hazard information.

* * * * *