



US 20100279062A1

(19) **United States**

(12) **Patent Application Publication**
Millward et al.

(10) **Pub. No.: US 2010/0279062 A1**

(43) **Pub. Date: Nov. 4, 2010**

(54) **ALTERNATING SELF-ASSEMBLING MORPHOLOGIES OF DIBLOCK COPOLYMERS CONTROLLED BY VARIATIONS IN SURFACES**

(22) Filed: **Jul. 12, 2010**

Related U.S. Application Data

(62) Division of application No. 11/761,589, filed on Jun. 12, 2007.

(76) Inventors: **Dan B. Millward**, Boise, ID (US);
Donald Westmoreland, Boise, ID (US);
Gurtej Sandhu, Boise, ID (US)

Publication Classification

(51) **Int. Cl.**
B32B 3/30 (2006.01)

(52) **U.S. Cl.** **428/119**

(57) **ABSTRACT**

Methods for fabricating sublithographic, nanoscale microstructures arrays including openings and linear microchannels utilizing self-assembling block copolymers, and films and devices formed from these methods are provided. In some embodiments, the films can be used as a template or mask to etch openings in an underlying material layer.

Correspondence Address:
WHYTE HIRSCHBOECK DUDEK S.C.
INTELLECTUAL PROPERTY DEPARTMENT
555 EAST WELLS STREET, SUITE 1900
MILWAUKEE, WI 53202 (US)

(21) Appl. No.: **12/834,097**

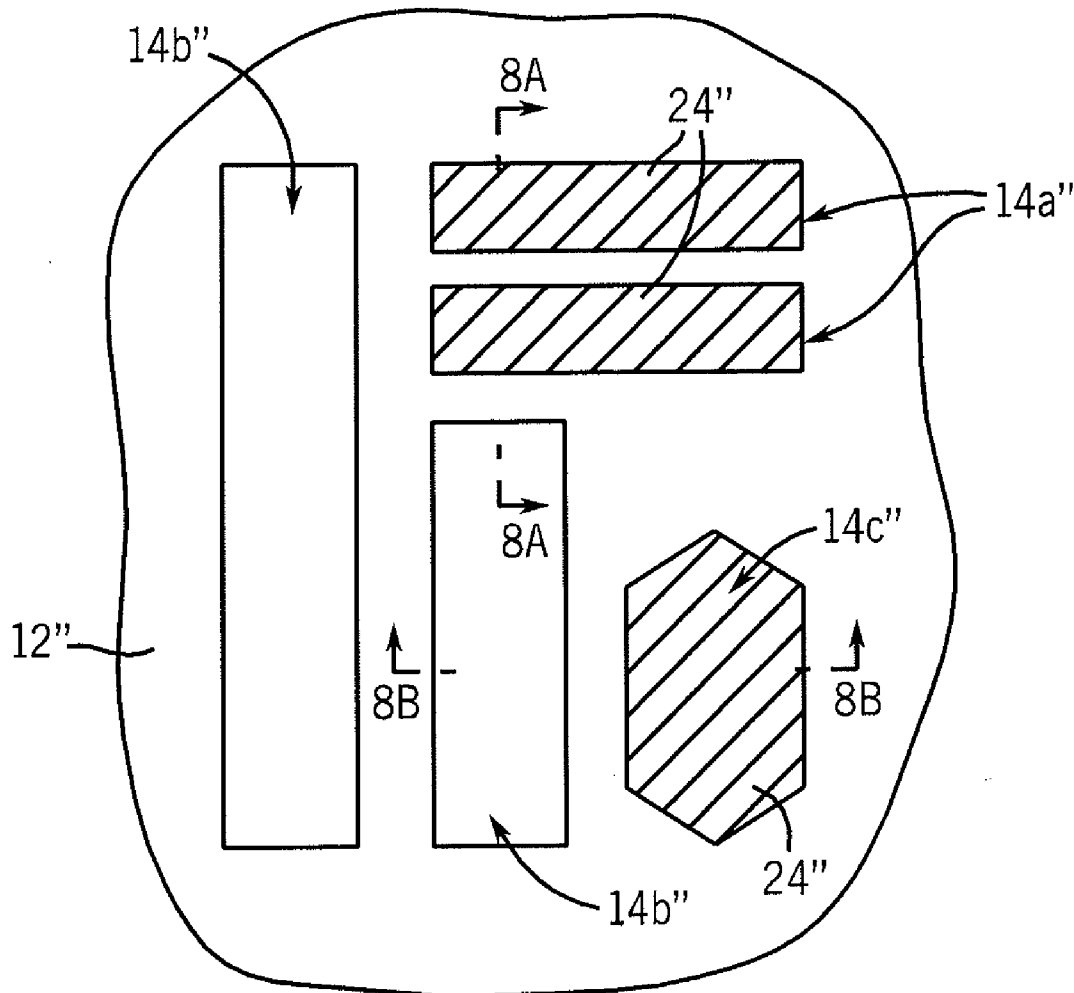

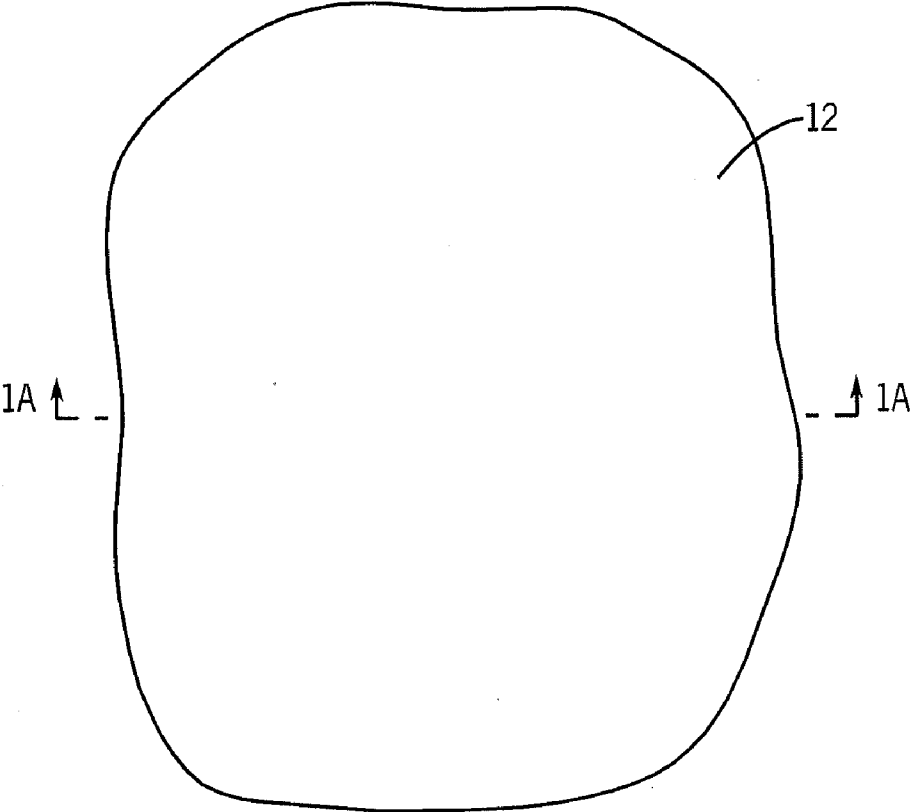

FIG. 1

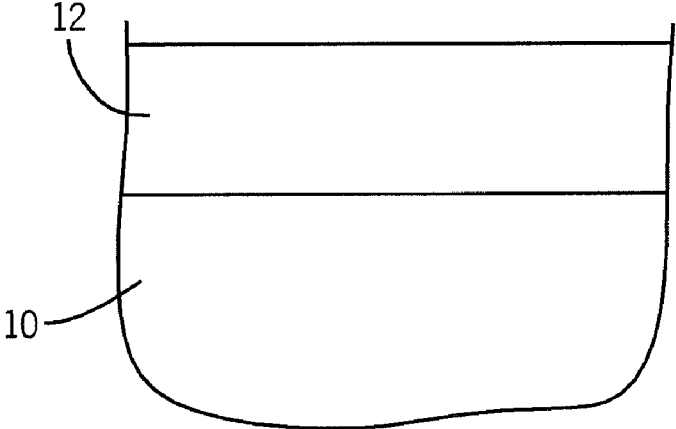

FIG. 1A

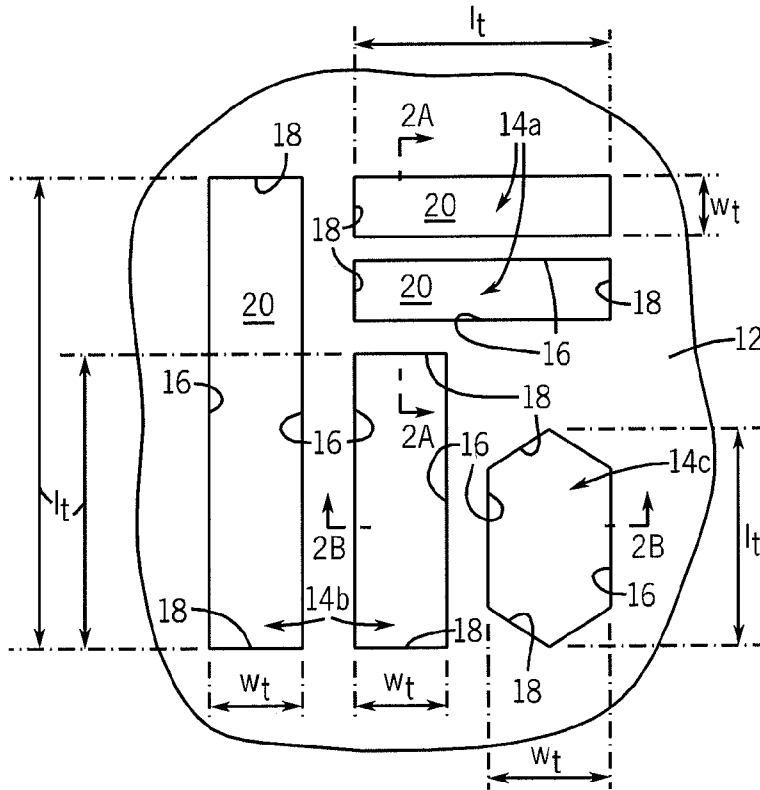

FIG. 2

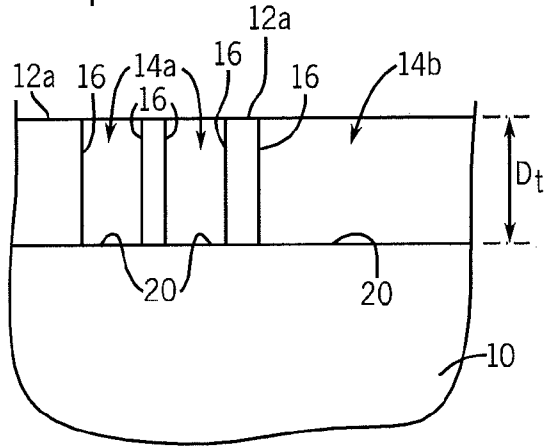

FIG. 2A

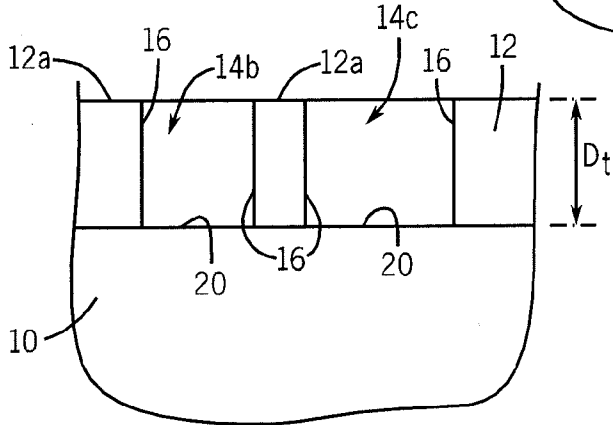

FIG. 2B

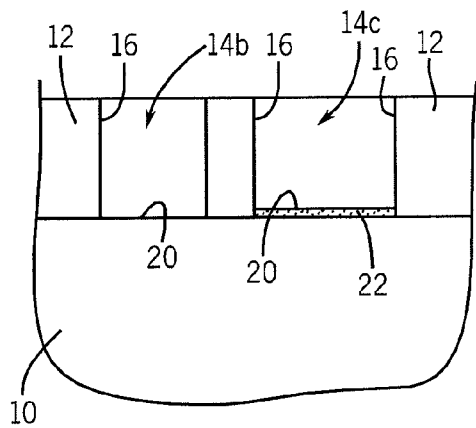
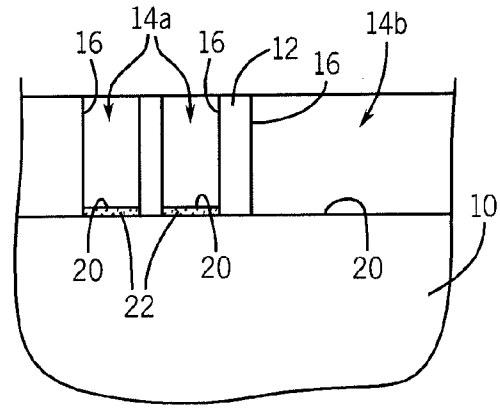
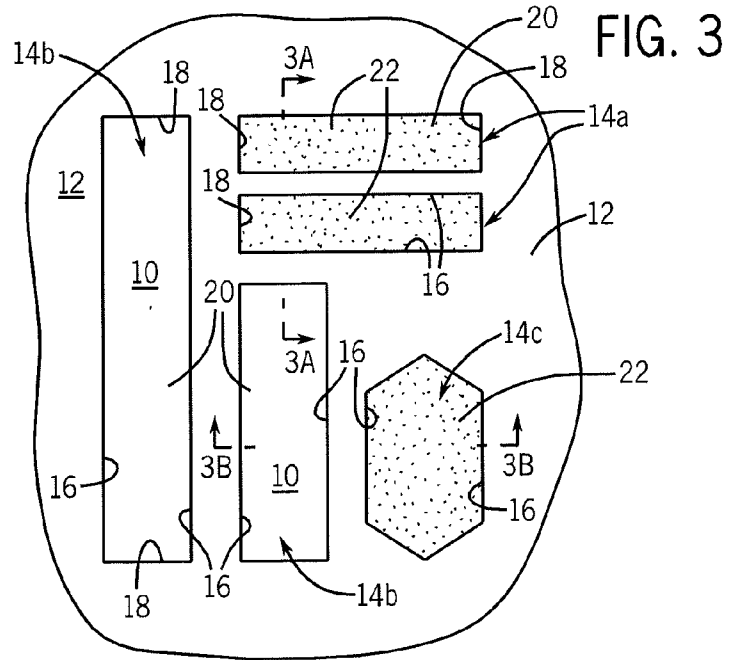

FIG. 3B

FIG. 3A

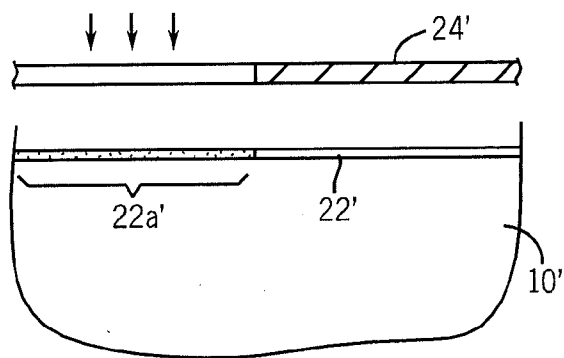
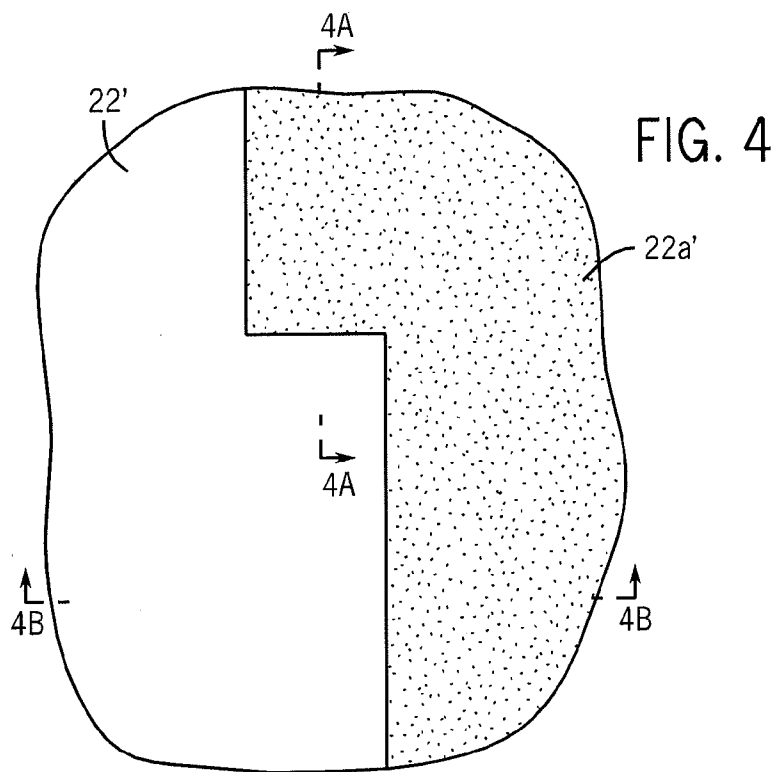

FIG. 4A

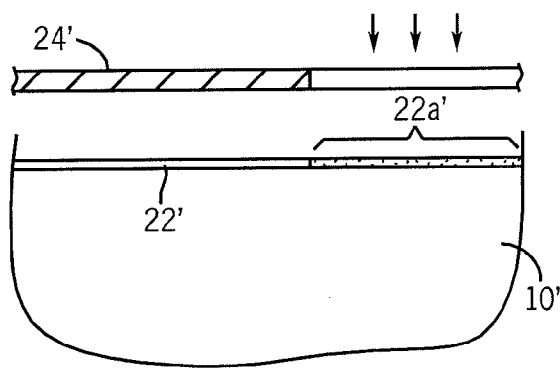

FIG. 4B

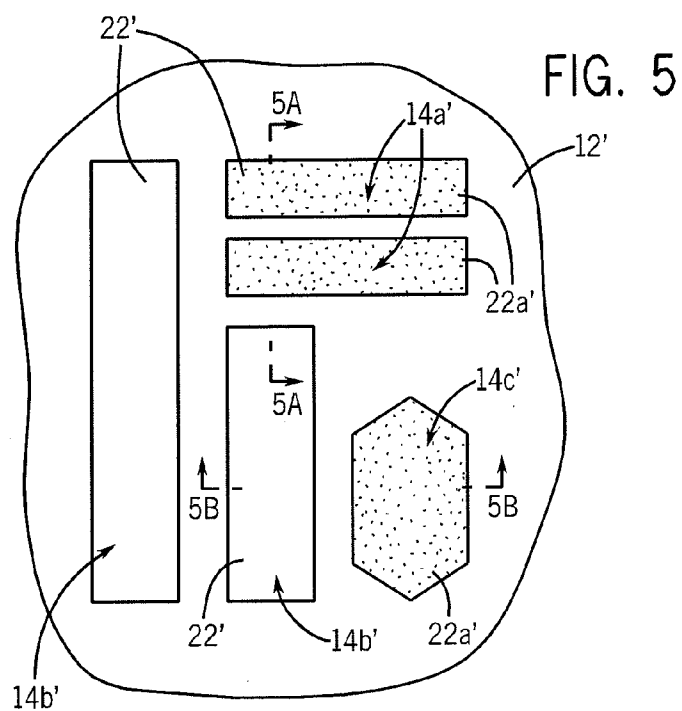

FIG. 5

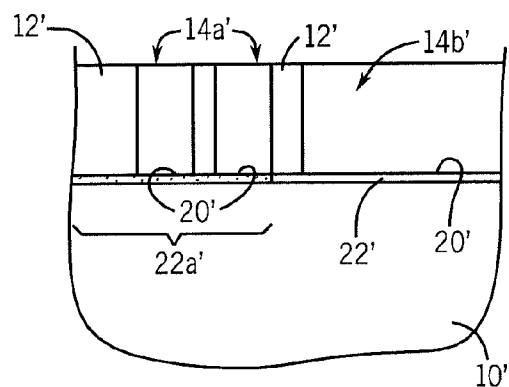

FIG. 5A

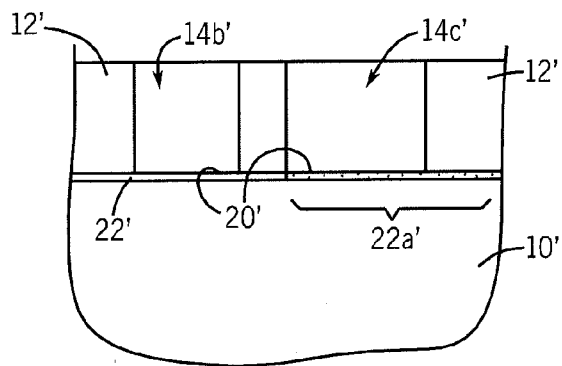

FIG. 5B

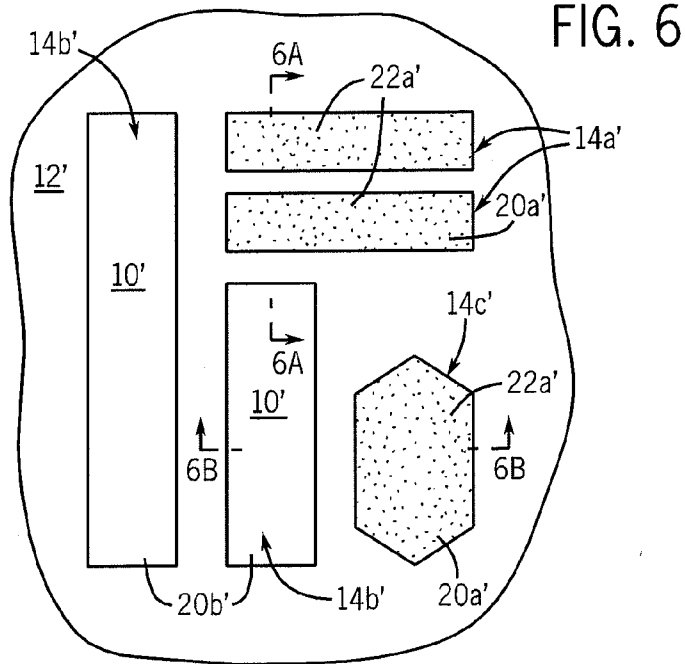

FIG. 6

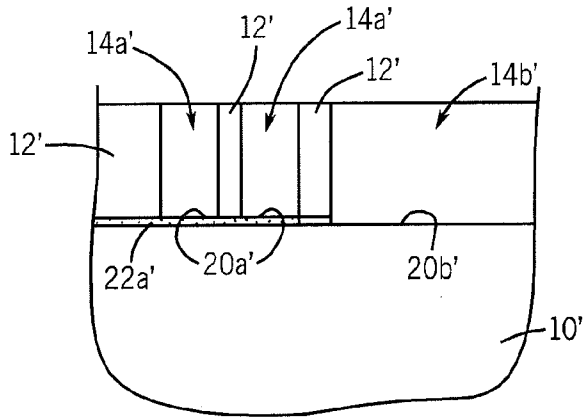

FIG. 6A

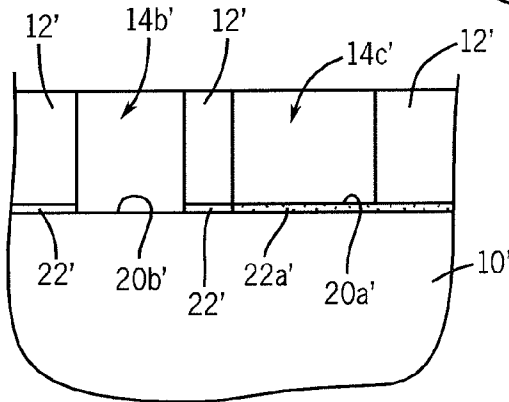

FIG. 6B

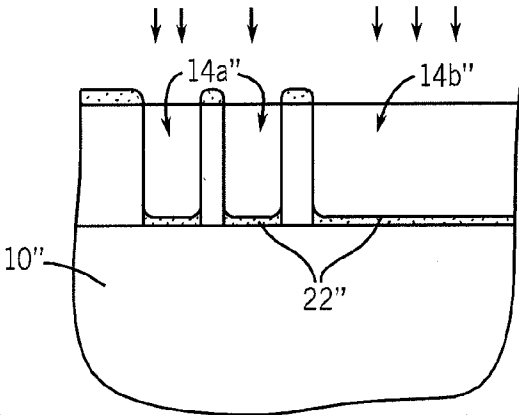
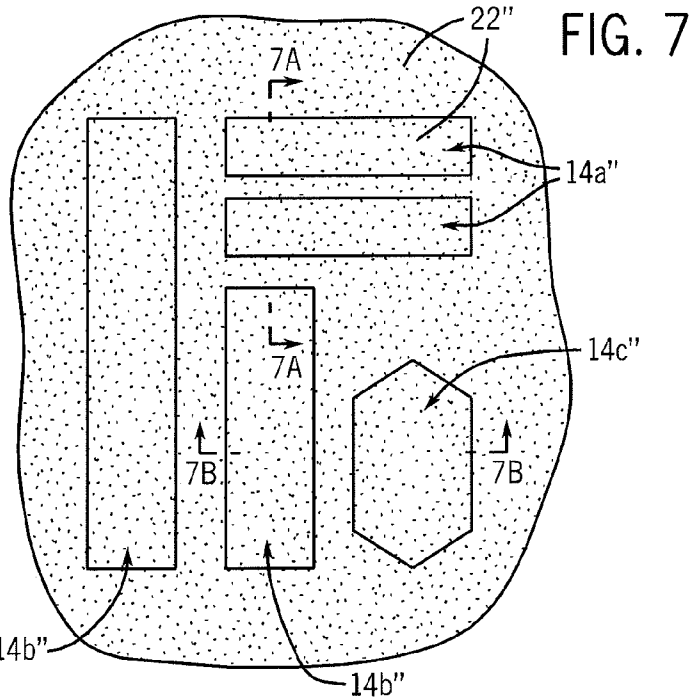

FIG. 7A

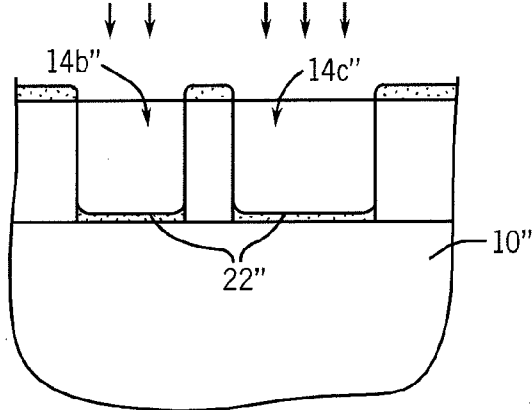

FIG. 7B

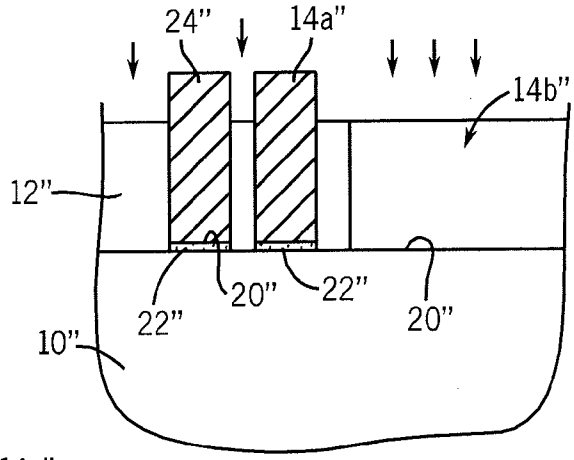
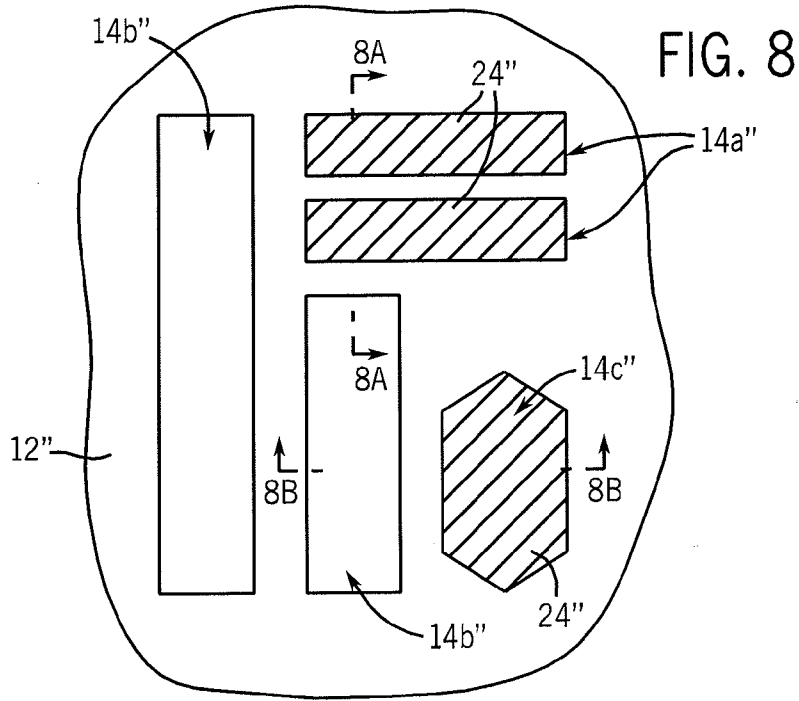

FIG. 8A

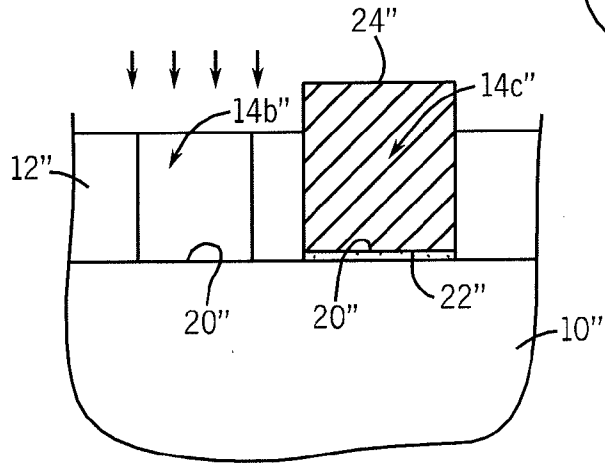

FIG. 8B

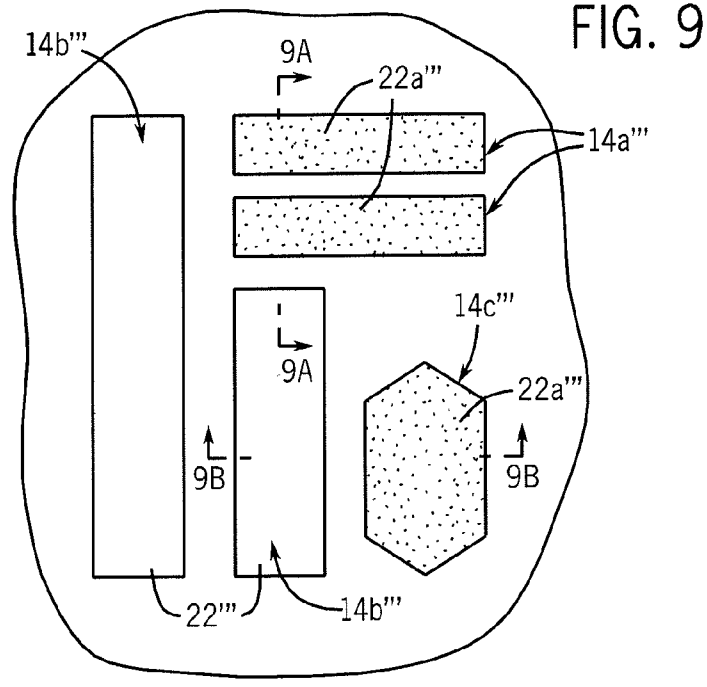

FIG. 9

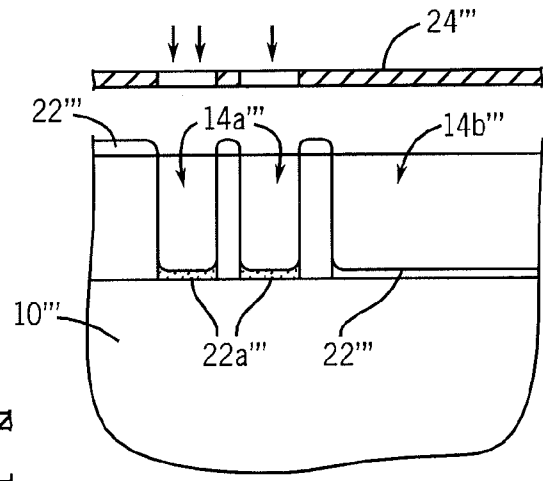

FIG. 9A

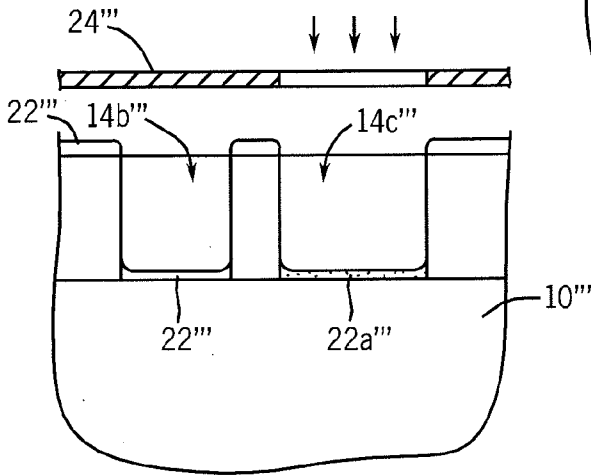
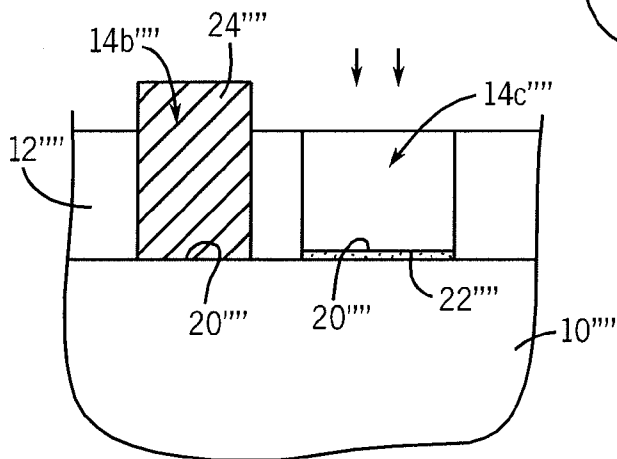
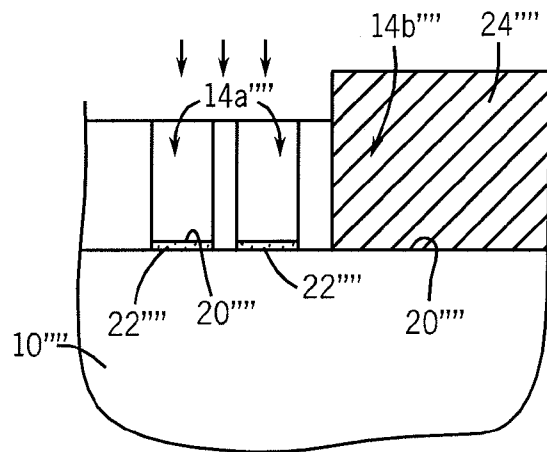
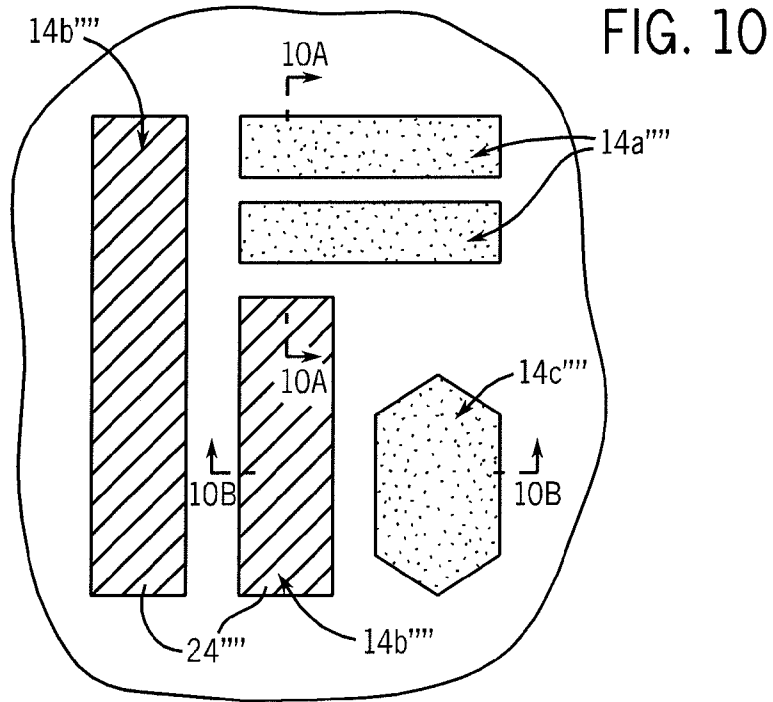

FIG. 9B



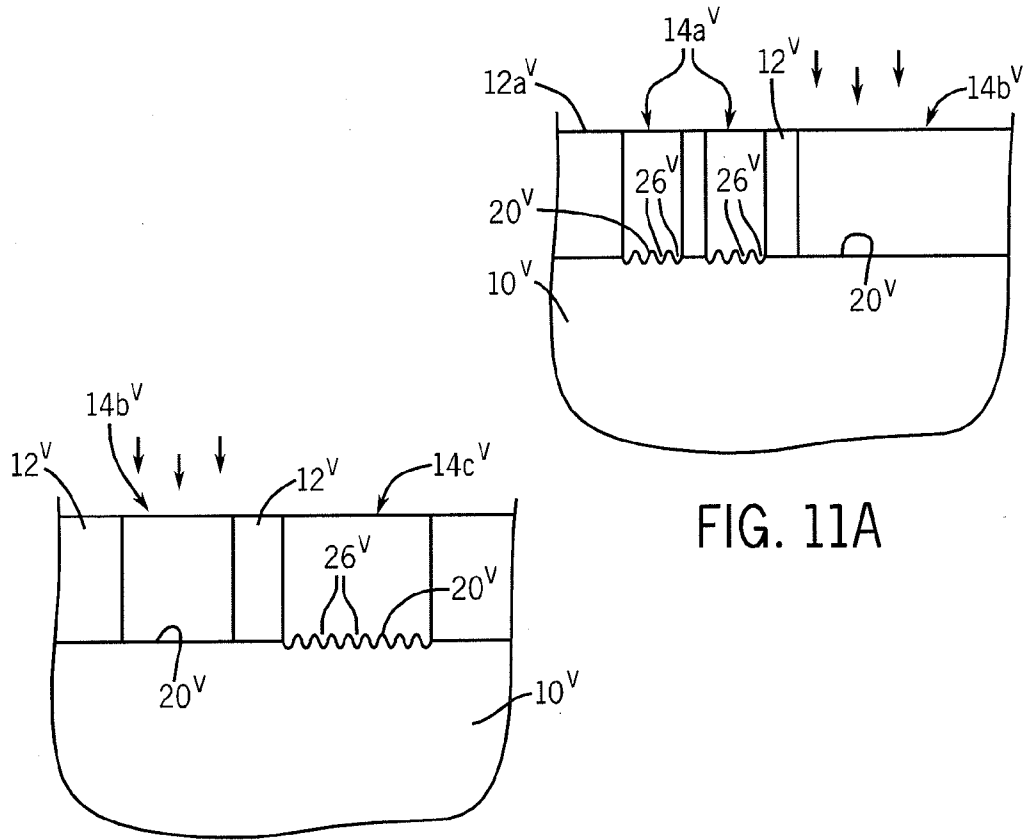
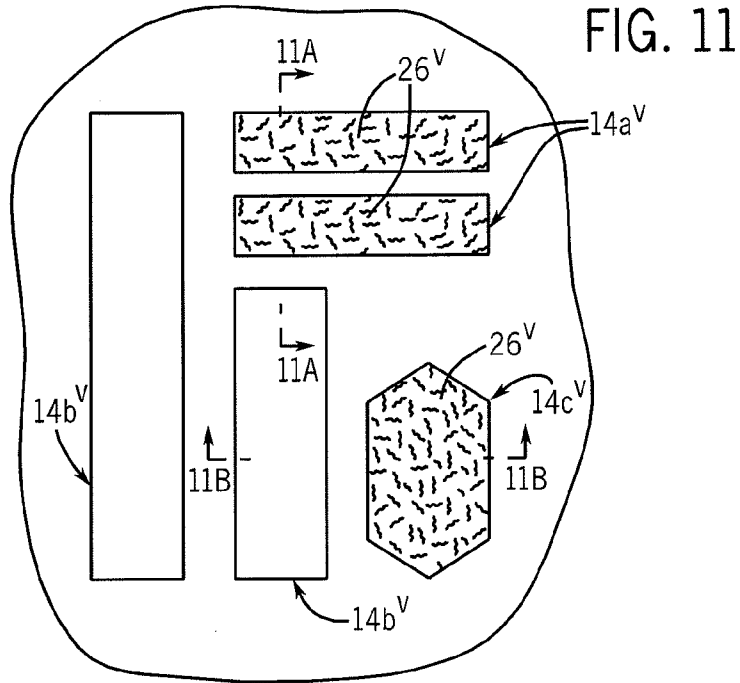

FIG. 11A

FIG. 11B

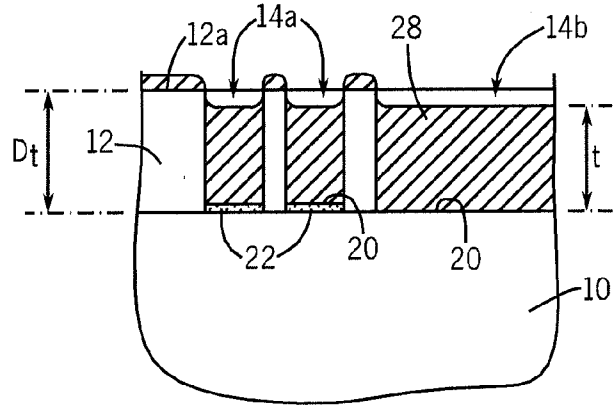
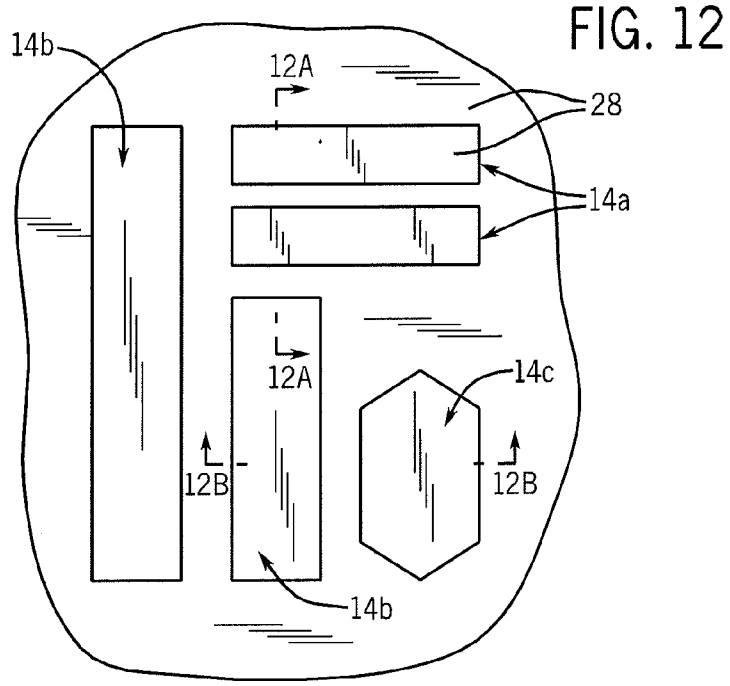

FIG. 12A

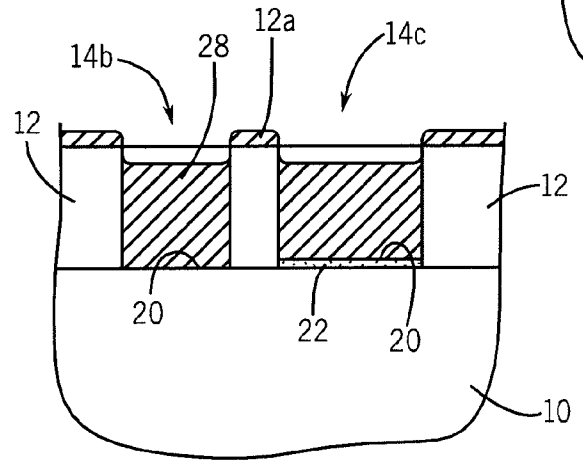

FIG. 12B

FIG. 13

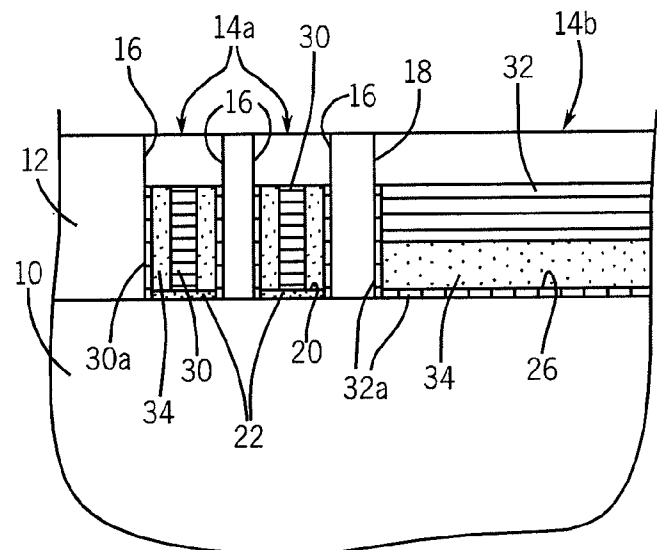
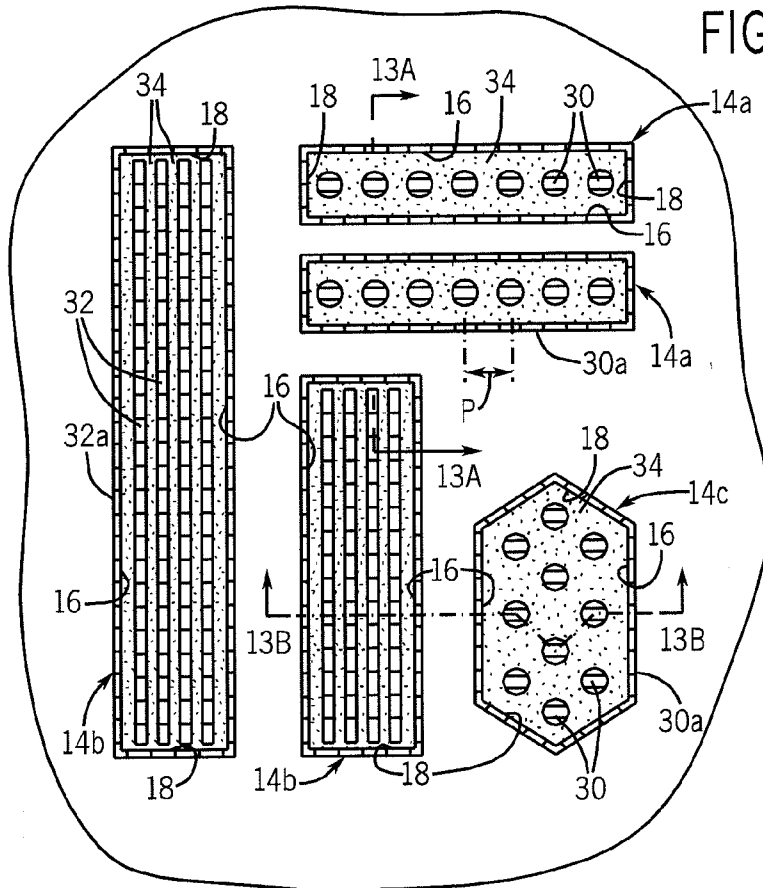
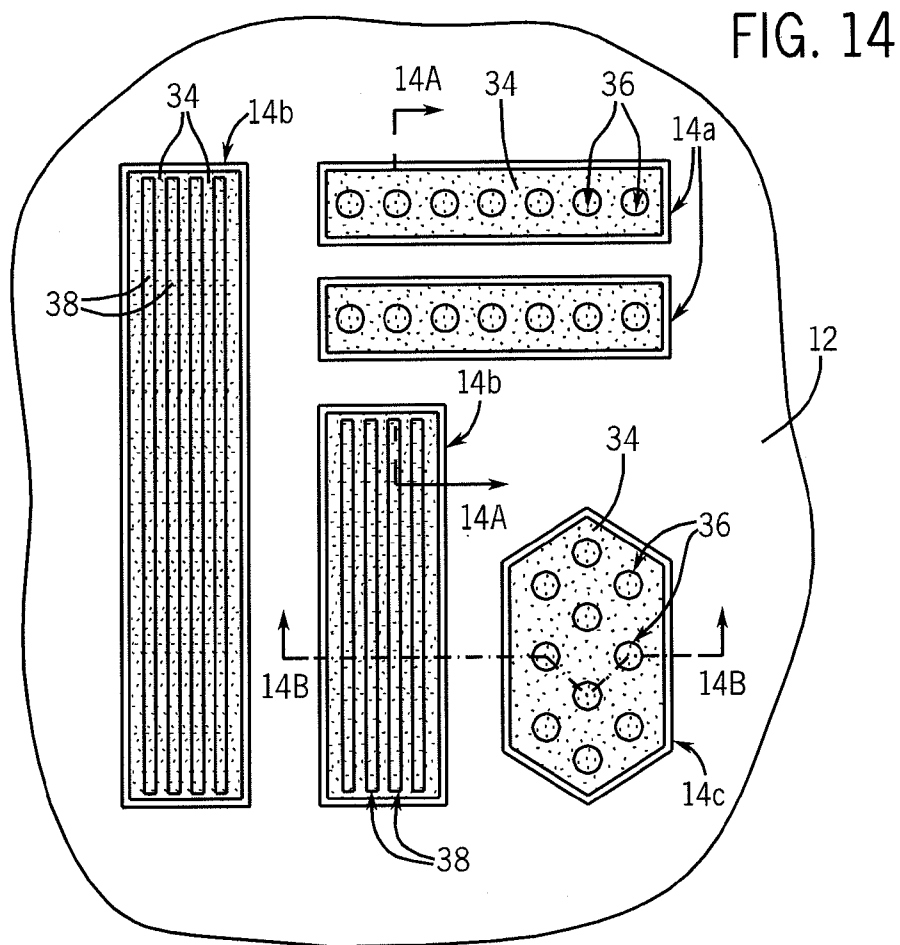
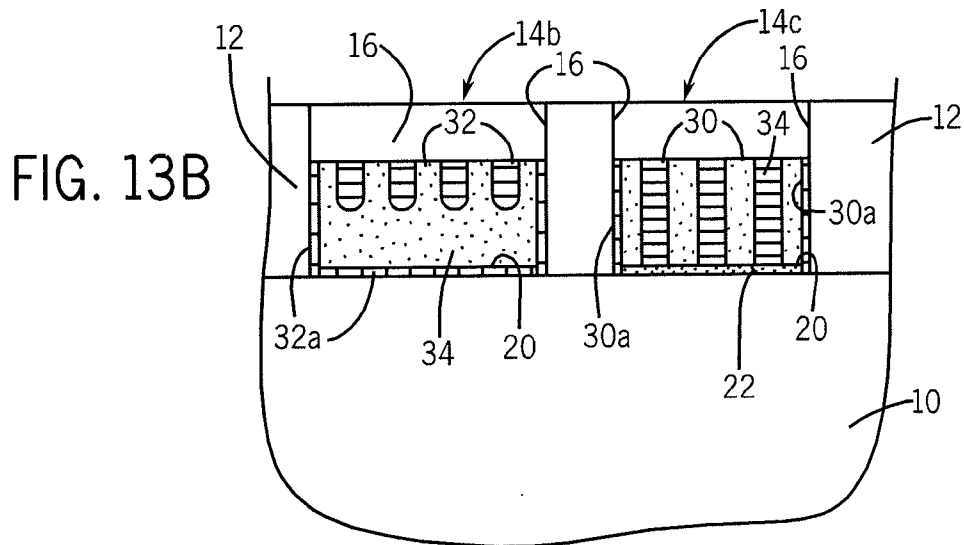

FIG. 13A



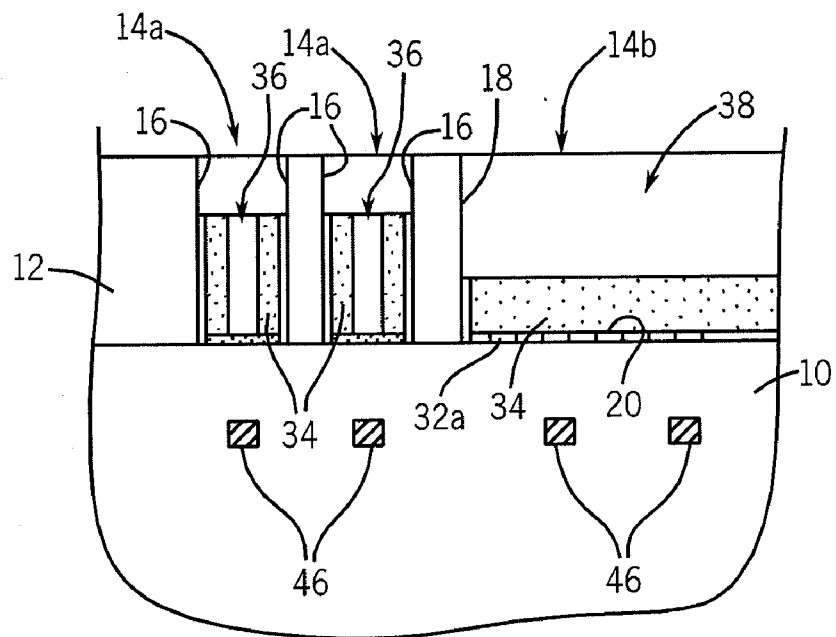

FIG. 14A

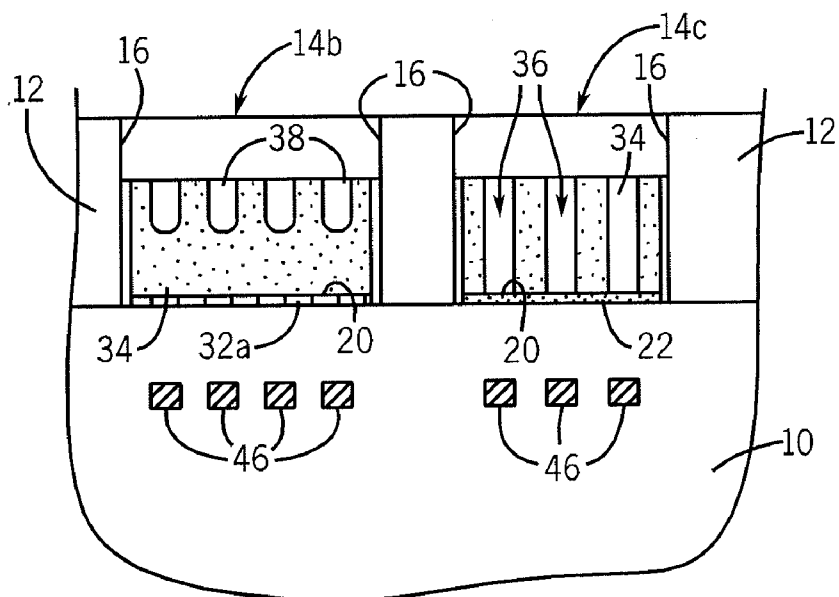

FIG. 14B

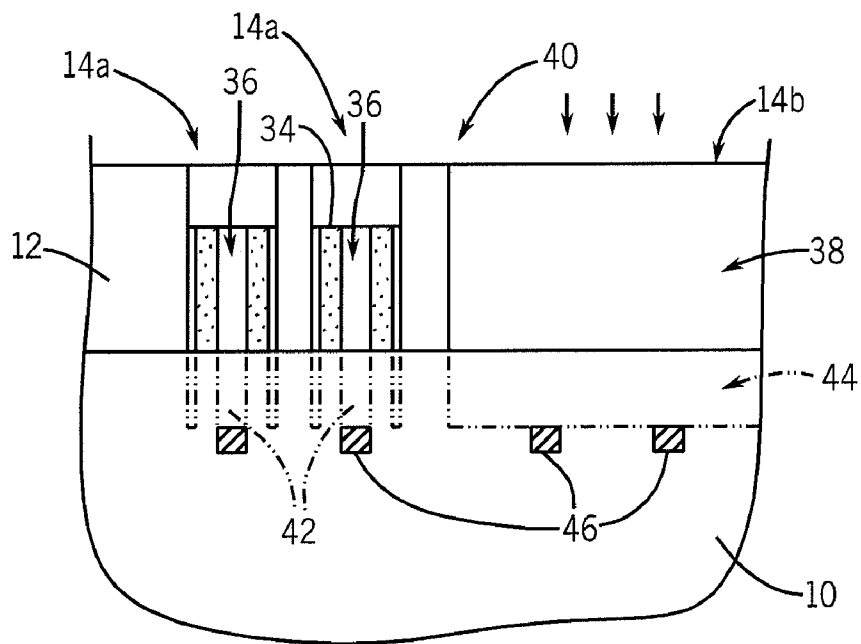

FIG. 15A

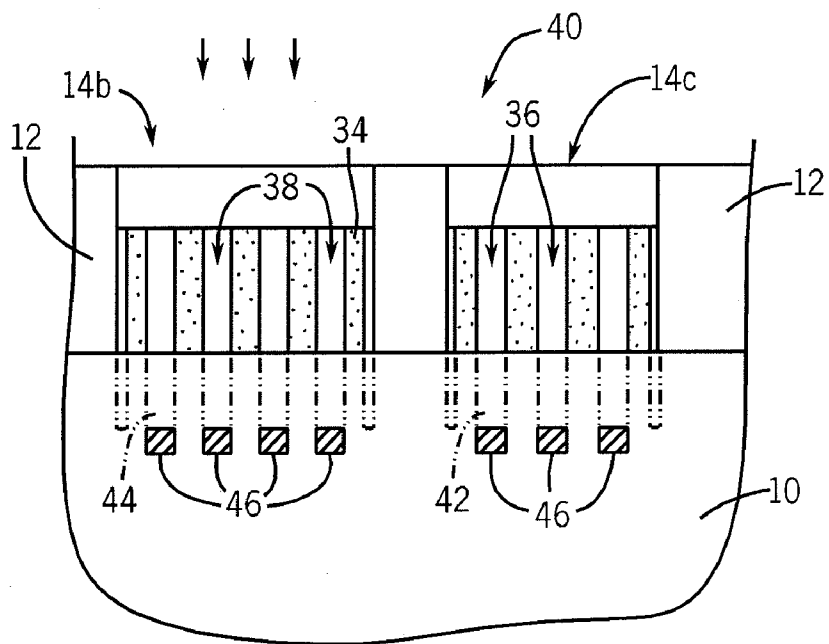
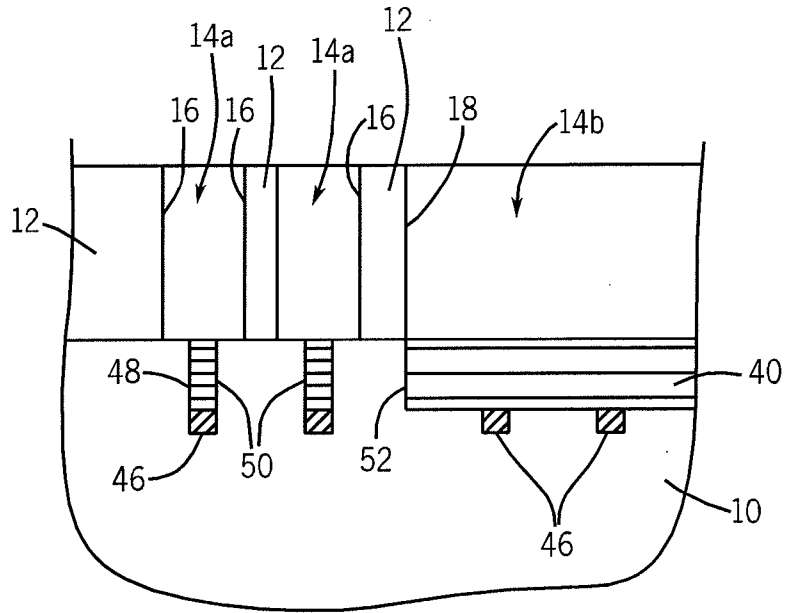
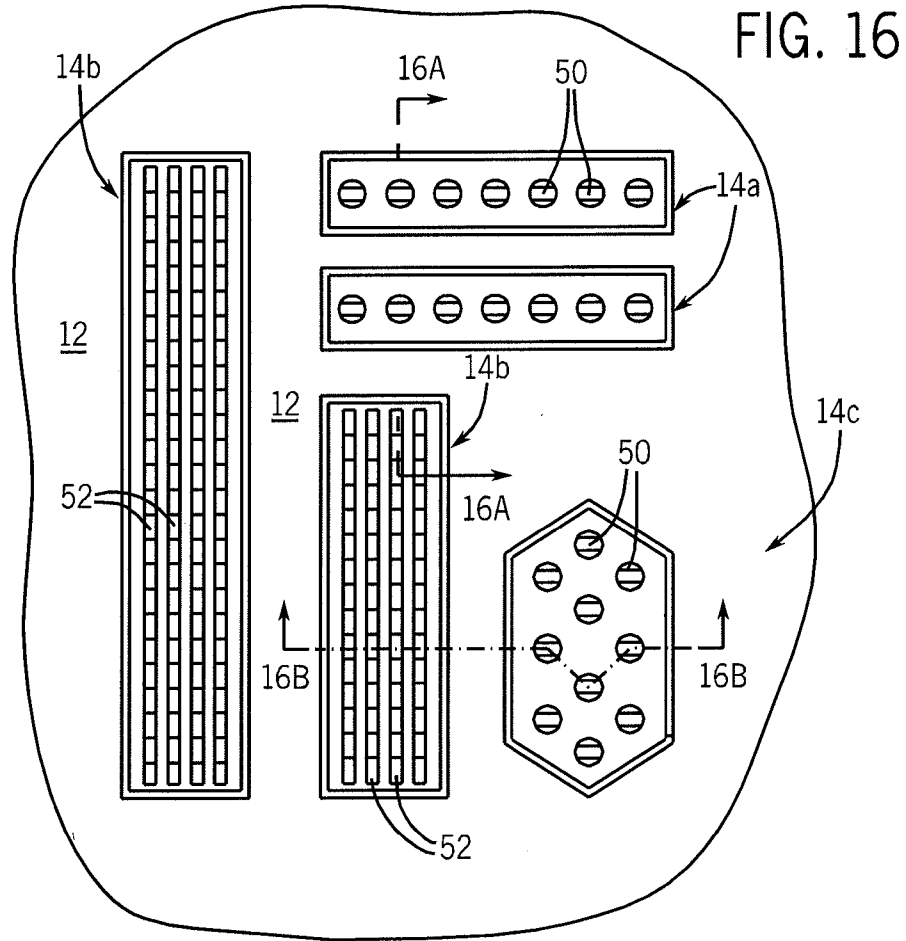

FIG. 15B



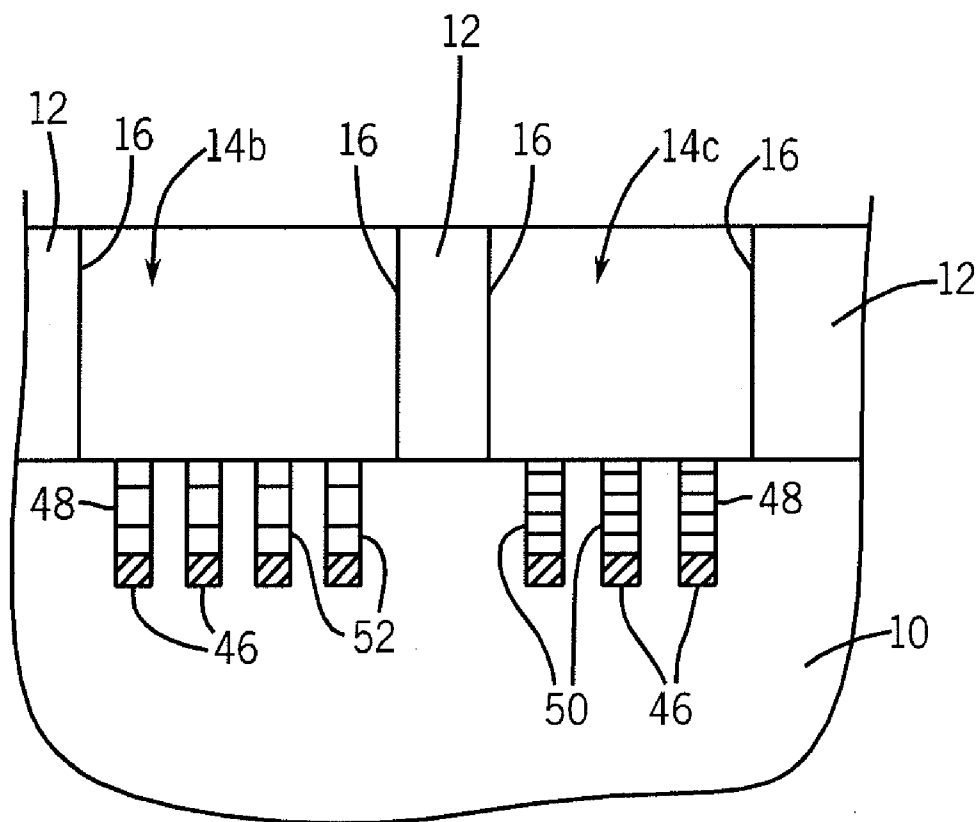

FIG. 16B

**ALTERNATING SELF-ASSEMBLING
MORPHOLOGIES OF DIBLOCK
COPOLYMERS CONTROLLED BY
VARIATIONS IN SURFACES**

**CROSS-REFERENCE TO RELATED
APPLICATION**

[0001] This application is a division of U.S. Ser. No. 11/761,589, filed Jun. 12, 2007, the entire content of which is incorporated by reference herein.

TECHNICAL FIELD

[0002] Embodiments of the invention relate to methods of fabricating nanostructures by use of thin films of self-assembling block copolymers, and devices resulting from those methods.

BACKGROUND OF THE INVENTION

[0003] As the development of nanoscale mechanical, electrical, chemical and biological devices and systems increases, new processes and materials are needed to fabricate nanoscale devices and components. Optical lithographic processing methods are not able to accommodate fabrication of structures and features at the nanometer level. The use of self assembling diblock copolymers presents another route to patterning at nanometer dimensions. Diblock copolymer films spontaneously assemble into periodic structures by microphase separation of the constituent polymer blocks after annealing, for example by thermal annealing above the glass transition temperature of the polymer or by solvent annealing, forming ordered domains at nanometer-scale dimensions. Following self assembly, one block of the copolymer can be selectively removed and the remaining patterned film used, for example, as an etch mask for patterning nanosized features into the underlying substrate. Since the domain sizes and periods (L_o) involved in this method are determined by the chain length of a block copolymer (MW), resolution can exceed other techniques such as conventional photolithography, while the cost of the technique is far less than electron beam (E-beam) lithography or EUV photolithography, which have comparable resolution.

[0004] The film morphology, including the size and shape of the microphase-separated domains, can be controlled by the molecular weight and volume fraction of the AB blocks of a diblock copolymer to produce lamellar, cylindrical, or spherical morphologies, among others. For example, for volume fractions at ratios greater than about 80:20 of the two blocks (AB) of a diblock polymer, a block copolymer film will microphase separate and self-assemble into a periodic spherical domains with spheres of polymer B surrounded by a matrix of polymer A. For ratios of the two blocks between about 60:40 and 80:20, the diblock copolymer assembles into periodic cylindrical domains of polymer B within a matrix of polymer A. For ratios between about 50:50 and 60:40, lamellar domains or alternating stripes of the blocks are formed. Domain size typically ranges from 5-50 nm.

[0005] Researchers have demonstrated the ability to chemically differentiate a surface such that some areas are preferentially wetting to one domain of a block copolymer and other areas are neutral wetting to both blocks. Periodic cylindrical structures have been grown in parallel and perpendicular orientations to substrates within trenches by thermal annealing cylindrical-phase block copolymers. A primary require-

ment for producing perpendicular cylinders is that the trench floor must be non-preferential or neutral wetting to both blocks of the copolymer. For producing parallel-oriented half-cylinders, the trench floor must be preferentially wetting by the minor copolymer block.

[0006] A film composed of periodic hexagonal close-packed cylinders, for example, can be useful in forming an etch mask to make structures in an underlying substrate for specific applications such as magnetic storage devices. However, many applications require a more complex layout of elements for forming contacts, conductive lines and/or other elements such as DRAM capacitors.

BRIEF DESCRIPTION OF THE DRAWINGS

[0007] Embodiments of the invention are described below with reference to the following accompanying drawings, which are for illustrative purposes only. Throughout the following views, the reference numerals will be used in the drawings, and the same reference numerals will be used throughout the several views and in the description to indicate same or like parts.

[0008] FIG. 1 illustrates a diagrammatic top plan view of a portion of a substrate at a preliminary processing stage according to an embodiment of the present disclosure. FIG. 1A is an elevational, cross-sectional view of the substrate depicted in FIG. 1 taken along lines 1A-1A.

[0009] FIGS. 2-3 are diagrammatic top plan views of the substrate of FIG. 1 at subsequent processing steps according to an embodiment of the invention. FIGS. 2A-3A illustrate elevational, cross-sectional views of a portion of the substrate depicted in FIGS. 2-3 taken, respectively, along lines 2A-2A and 3A-3A. FIGS. 2B-3B illustrate elevational, cross-sectional views of another portion of the substrate depicted in FIGS. 2-3 taken, respectively, along lines 2B-2B and 3B-3B.

[0010] FIG. 4 is a diagrammatic top plan view of a portion of a substrate at a preliminary processing stage according to another embodiment of the disclosure. FIGS. 4A-4B are elevational, cross-sectional views of portions of the substrate depicted in FIG. 4 taken, respectively, along lines 4A-4A and 4B-4B.

[0011] FIGS. 5-6 illustrate diagrammatic top plan views of the substrate depicted in FIG. 4 at subsequent processing stages. FIGS. 5A-6A are elevational, cross-sectional views of a portion of the substrates depicted in FIGS. 5-6, respectively, taken along lines 5A-5A and 6A-6A. FIGS. 5B-6B are elevational, cross-sectional views of another portion of the substrate depicted in FIGS. 5-6, respectively, taken along lines 5B-5B and 6B-6B.

[0012] FIGS. 7-8 are diagrammatic top plan views of the substrate of FIG. 2 at subsequent processing steps according to another embodiment of the invention. FIGS. 7A-8A illustrate elevational, cross-sectional views of a portion of the substrate depicted in FIGS. 7-8 taken, respectively, along lines 7A-7A and 8A-8A. FIGS. 7B-8B are elevational, cross-sectional views of a portion of the substrate depicted in FIGS. 7-8 taken, respectively, along lines 7B-7B and 8B-8B.

[0013] FIG. 9 is a diagrammatic top plan view of the substrate of FIG. 2 at a subsequent processing step according to another embodiment of the invention to form preferential and neutral wetting surfaces. FIGS. 9A-9B illustrate elevational, cross-sectional views of a portion of the substrate depicted in FIG. 9 taken, respectively, along lines 9A-9A and 9B-9B.

[0014] FIG. 10 is a diagrammatic top plan view of the substrate of FIG. 2 at a subsequent processing step according

to another embodiment of the disclosure. FIGS. 10A-10B depict elevational, cross-sectional view of a portion of the substrate depicted in FIG. 10 taken, respectively, along lines 10A-10A and 10B-10B.

[0015] FIG. 11 is a diagrammatic top plan view of the substrate of FIG. 2 at a subsequent processing step according to another embodiment of the invention to form roughened trench floors for a preferential wetting surface. FIGS. 11A-11B illustrate elevational, cross-sectional views of a portion of the substrate depicted in FIG. 11 taken, respectively, along lines 11A-11A and 11B-11B.

[0016] FIGS. 12-13 are diagrammatic top plan views of the substrate of FIG. 3 at subsequent stages in the fabrication of a film composed of arrays of cylindrical domains according to an embodiment of the present disclosure.

[0017] FIGS. 14 and 16 are top plan views of the substrate of FIG. 13 at subsequent processing steps according to an embodiment of the invention to form a mask and arrays of conductive contacts and lines in a substrate. FIGS. 12A-14A and 16A are elevational, cross-sectional views of a portion of the substrate depicted in FIGS. 12-14 and 16 taken, respectively, along lines 12A-12A to 14A-14A and 16A-16A. FIGS. 12B-14B and 16B are elevational, cross-sectional views of a portion of the substrate depicted in FIGS. 12-14 and 16 taken, respectively, along lines 12B-12B to 14B-14B and 16B-16B.

[0018] FIGS. 15A-15B are cross-sectional views of the substrate depicted in FIGS. 14A-14B, respectively, at a subsequent processing stage.

DETAILED DESCRIPTION OF THE INVENTION

[0019] The following description with reference to the drawings provides illustrative examples of devices and methods according to embodiments of the invention. Such description is for illustrative purposes only and not for purposes of limiting the same.

[0020] In the context of the current application, the term “semiconductor substrate” or “semiconductive substrate” or “semiconductive wafer fragment” or “wafer fragment” or “wafer” will be understood to mean any construction comprising semiconductor material, including but not limited to bulk semiconductive materials such as a semiconductor wafer (either alone or in assemblies comprising other materials thereon), and semiconductive material layers (either alone or in assemblies comprising other materials). The term “substrate” refers to any supporting structure including, but not limited to, the semiconductive substrates, wafer fragments or wafers described above.

[0021] “ L_0 ” is the inherent pitch (bulk period or repeat unit) of structures that self assemble upon annealing from a self-assembling (SA) block copolymer or a blend of a block copolymer with one or more of its constituent homopolymers.

[0022] In embodiments of the invention, processing conditions utilize graphoepitaxy techniques that use topographical features, e.g., the sidewalls and ends of trenches, as constraints to induce the formation and registration of polymer domains of cylindrical-phase diblock copolymers in one dimension (e.g., hexagonal close-packed (honeycomb) array or single row of perpendicular cylinders) and chemically or structurally (topographically) differentiated trench floors to provide a wetting pattern to control orientation of the microphase separated and self-assembling cylindrical domains in a second dimension (e.g., parallel lines of half-cylinders or perpendicular-oriented cylinders). The trench floors are structured or composed of surface materials to

provide a neutral wetting surface or preferential wetting surface to impose ordering on a block copolymer film that is then cast on top of the substrate and annealed to produce desired arrays of nanoscale cylinders.

[0023] Embodiments of the invention provide a means of generating self-assembled diblock copolymer structures wherein perpendicular cylinders are formed in some trenches and parallel-oriented half-cylinders are formed in other trenches. Control of the orientation of the cylinders is provided by the nature of the trench floor surface. Graphoepitaxy is used to provide parallel lines of half-cylinders, hexagonal close-packed arrays of perpendicular cylinders, or a single row of perpendicular cylinders within lithographically defined trenches. A desired pattern of cylinders on a substrate, e.g., a wafer, can be prepared by providing trenches having walls that are selective to one polymer block of a block copolymer and a floor composed either of a material that is block-sensitive or preferentially wetting to one of the blocks of the block copolymer in trenches where lines of parallel half-cylinders are desired, or a material that is neutral wetting to both blocks in trenches where an array of perpendicular cylinders are desired. Embodiments of the invention can be used to pattern lines and openings (holes) in the same patterning step at pre-determined locations on a substrate.

[0024] Embodiments of the invention of methods for fabricating arrays of cylinders from thin films of cylindrical-phase self assembling (SA) block copolymers are described with reference to the figures. As shown in FIGS. 1-1A, a substrate 10 to be etched is provided, being silicon in the illustrated embodiment. Overlying the substrate 10 is a material layer 12. As illustrated in FIGS. 2-2B, the material layer 12 is etched to form a desired pattern of trenches shown as trenches 14a, 14b and 14c.

[0025] The trenches can be formed using a lithographic tool having an exposure system capable of patterning at the scale of L_0 (10-100 nm). Such exposure systems include, for example, extreme ultraviolet (EUV) lithography, dry lithography (e.g., 248 nm, 193 nm), immersion lithography (e.g., 193 nm), and electron beam lithography, as known and used in the art. Conventional photolithography can attain about 58 nm features. A method called “pitch doubling” or “pitch multiplication” can also be used for extending the capabilities of photolithographic techniques beyond their minimum pitch, as described, for example, in U.S. Pat. No. 5,328,810 (Lowrey et al.), U.S. Pat. No. 7,115,525 (Abatchev, et al.), US 2006/0281266 (Wells) and US 2007/0023805 (Wells), the disclosures of which are incorporated by reference herein. Briefly, a pattern of lines is photolithographically formed in a photoresist layer overlying a layer of an expendable material, which in turn overlies a substrate, the expendable material layer is etched to form placeholders or mandrels, the photoresist is stripped, spacers are formed on the sides of the mandrels, and the mandrels are then removed leaving behind the spacers as a mask for patterning the substrate. Thus, where the initial photolithography formed a pattern defining one feature and one space, the same width now defines two features and two spaces, with the spaces defined by the spacers. As a result, the smallest feature size possible with a photolithographic technique is effectively decreased down to about 30 nm or more.

[0026] The trenches 14a-14c are structured with opposing sidewalls 16, opposing ends 18, a floor 20, a width (w_t), a length (l_t) and a depth (D_t). Trench 14c is also structured with the trench ends 18 angled to the sidewalls 16, for example, at

an about 60° angle, and in some embodiments, the trench ends are slightly rounded. Portions of the material layer **12** form a spacer **12a** between the trenches.

[0027] The trench sidewalls, edges and floors influence the self-assembly of the polymer blocks and the structuring of the array of nanostructures within the trenches. The boundary conditions of the trench sidewalls **16** impose order in the x-direction (x-axis) and the ends **18** impose order in the y-direction (y-axis) to impose a structure wherein each trench contains n number of features (i.e., cylinders). Other factors that influence the formation and alignment of elements within the trench include the width (w_t) of the trench, the formulation of the block copolymer to achieve the desired pitch (L_o), the thickness (t) of the block copolymer film, and the wetting nature of the trench surfaces.

[0028] Entropic forces drive the wetting of a neutral wetting surface by both blocks, and enthalpic forces drive the wetting of a preferential-wetting surface by the preferred block (e.g., the minority block). The trench sidewalls **16** and ends **18** are structured to be preferential wetting such that upon annealing, the preferred block of the block copolymer will segregate to the sidewalls and edges of the trench to assemble into a thin (e.g., ¼ pitch) interface (wetting) layer, and will self-assemble to form cylinders in the center of a polymer matrix within each trench, the cylinders being in a perpendicular orientation on neutral wetting floor surfaces and half-cylinders in a parallel orientation in relation to preferential wetting floor surfaces.

[0029] As illustrated in FIGS. 2-2B, trenches **14a** are constructed with a width (w_t) of about $2*L_o$ or less, e.g., about $1.5*L_o$ to about $2*L_o$ (e.g., about $1.75*L_o$) (L_o being the inherent periodicity or pitch value of the block copolymer) for forming a 1-D array of cylinders with a center-to-center pitch of at or about L_o (e.g., a width of about 65-75 nm for a L_o value of about 36-42 nm). Trenches **14b**, **14c** have a width (w_t) at or about an integer multiple of the L_o value or nL_o where $n=3, 4, 5$, etc. (e.g., a width of about 120-2,000 nm for a L_o value of about 36-42 nm). The length (l) of the trenches is at or about nL_o where n is an integer multiple of L_o , typically within a range of about $n*10$ – $n*100$ nm (with n being the number of features or structures (i.e., cylinders)). The depth (D) of the trenches generally over a range of about 50-500 nm. The width of the spacer **12a** between adjacent trenches can vary and is generally about L_o to about nL_o .

[0030] As shown in FIGS. 3-3B, the floors **20** of trenches **14a**, **14c** have a neutral wetting surface (layer **22**) to induce formation of perpendicular cylinders within those trenches, and the floors **20** of trenches **14b** are preferential wetting by one block of a self-assembling block copolymer to induce formation of parallel half-cylinders in those trenches. The application and annealing of a cylindrical-phase block copolymer material having an inherent pitch value of about L_o in the trenches will result in a single row of “n” perpendicular cylinders in trenches **14a** for the length of the trenches, “n” rows or lines of half-cylinders (parallel to the sidewalls and trench floor) extending the length (l_t) and spanning the width (w_t) of trenches **14b**, and a periodic hexagonal close-pack or honeycomb array of perpendicular cylinders within trench **14c**. The cylindrical domains are separated by a center-to-center distance (pitch distance (p)) of at or about L_o .

[0031] For example, a block copolymer having a 35-nm pitch (L_o value) deposited into a 75-nm wide trench having a neutral wetting floor will, upon annealing, result in a zigzag pattern of 35-nm diameter perpendicular cylinders that are

offset by a half distance for the length (l_b) of the trench, rather than a single line of perpendicular cylinders aligned with the sidewalls down the center of the trench. As the L_o value of the copolymer is increased, for example, by forming a ternary blend by the addition of both constituent homopolymers, there is a shift from two rows to one row of the perpendicular cylinders within the center of the trench.

[0032] In some embodiments, the substrate **10** can be a material that is inherently preferential wetting to one of the blocks, and a neutral wetting surface layer **22** can be provided by applying a neutral wetting polymer (e.g., a neutral wetting random copolymer) onto the substrate **10** and then selectively removing the layer **22** to expose portions of the preferential wetting surface of the substrate. For example, in the use of a poly(styrene-block-methyl methacrylate) block copolymer (PS-b-PMMA), a random PS:PMMA copolymer (PS-r-PMMA) which exhibits non-preferential or neutral wetting toward PS and PMMA can be applied. The polymer layer can be affixed by grafting (on an oxide substrate) or by cross-linking (any surface) using UV radiation or thermal processing.

[0033] As shown in FIGS. 4-4B, in some embodiments, a neutral wetting layer **22'** can be formed on the substrate **10'** prior to forming the overlying material layer **12'**. For example, a blanket layer **22'** of a photo-crosslinkable random copolymer (e.g., PS-r-PMMA) can be spin coated onto the substrate **10'** and photo-crosslinked (arrows $\downarrow\downarrow\downarrow$) in select areas **22a'** using a reticle **24'**, for example. The material layer **12'** can then be formed over layer **22'** and the trenches etched to expose the neutral wetting layer **22'** at the trench floors **20'**, as depicted in FIGS. 5-5B, including crosslinked sections **22a'**. As shown in FIGS. 6-6B, non-crosslinked and exposed regions of the neutral wetting layer **22'** can then be selectively removed, e.g., by a solvent rinse, to expose the substrate **10'** (e.g., silicon with native oxide) as a preferential wetting surface **20b'** in trenches **14b'**, with the crosslinked neutral wetting layer **22a'** providing a neutral wetting surface **20a'** in trenches **14a'**, **14c'**.

[0034] In another embodiment depicted in FIGS. 7-7B, a neutral wetting random copolymer can be applied after forming the trenches, for example, as a blanket coat by spin-coating into each of the trenches **14a''-14c''** and thermally processed ($\downarrow\downarrow\downarrow$) to flow the material into the bottom of the trenches by capillary action, which can result in crosslinking the neutral wetting polymer layer **22''**. To remove the crosslinked polymer layer **22''** from selected regions, a photoresist layer **24''** can be coated over the structure, patterned and developed as shown in FIGS. 8-8B, and an oxygen (O_2) dry etch (arrows $\downarrow\downarrow\downarrow$) can be conducted to remove the crosslinked random copolymer layer **22''** from trenches **14b''** where a preferential wetting floor is desired, by exposing the substrate **10''** (e.g., silicon with native oxide). The photoresist **24''** can then be removed, resulting in the structure shown in FIGS. 3-3B.

[0035] For example, a neutral wetting polymer (NWP) such as a random copolymer of polystyrene (PS), polymethacrylate (PMMA) with hydroxyl group(s) (e.g., 2-hydroxyethyl methacrylate (P(S-r-MMA-r-HEMA))) (e.g., about 58% PS) can be selectively grafted to a material layer (e.g., an oxide floor) as a layer **22''** of about 5-10 nm thick by heating at about 160° C. for about 48 hours (FIGS. 7-7B). See, for example, In et al., *Langmuir*, 2006, 22, 7855-7860, the disclosure of which is incorporated by reference herein. The grafted polymer can then be removed from trenches **14b''** by

applying and developing a photoresist layer **24**" and etching (e.g., O₂ dry etch) the exposed polymer layer **22**" to produce preferential wetting floors (e.g., substrate **10**" of silicon with native oxide) in trenches **14b**" (FIGS. **8-8B**).

[0036] A surface that is neutral wetting to PS-b-PMMA can also be prepared by spin coating a blanket layer of a photo- or thermally cross-linkable random copolymer such as a benzocyclobutene- or azidomethylstyrene-functionalized random copolymer of styrene and methyl methacrylate (e.g., poly(styrene-r-benzocyclobutene-r-methyl methacrylate (PS-r-PMMA-r-BCB)). For example, such a random copolymer can comprise about 42% PMMA, about (58-x)% PS and x% (e.g., about 2-3%) of either polybenzocyclobutene or poly(parazidomethylstyrene)). An azidomethylstyrene-functionalized random copolymer can be UV photo-crosslinked (e.g., 1-5 MW/cm² exposure for about 15 seconds to about 30 minutes) or thermally crosslinked (e.g., at about 170° C. for about 4 hours) to form a crosslinked polymer mat as a neutral wetting layer **22**". A benzocyclobutene-functionalized random copolymer can be thermally cross-linked (e.g., at about 200° C. for about 4 hours or at about 250° C. for about 10 minutes). The layer **22**" can be globally photo- or thermal-crosslinked (FIGS. **7-7B**), masked using a patterned photoresist **24**" (FIGS. **8-8B**), and the unmasked sections can be selectively removed by etching (arrows ↓↓↓) (e.g., O₂ etch) to expose preferential-wetting floors **20**", e.g., substrate **10**" of silicon with native oxide, in trenches **14b**".

[0037] In other embodiments, as illustrated in FIGS. **9-9B**, portions of the neutral wetting layer **22**" in trenches **14a**", **14c**" can be photo-crosslinked through a reticle **24**" (arrows ↓↓↓) and the non-crosslinked material in trenches **14b**" can be removed, for example, using a solvent rinse, resulting in the structure shown in FIGS. **3-3B**.

[0038] Referring now to FIGS. **10-10B**, in another embodiment in which the substrate **10**" is silicon (with native oxide), another neutral wetting surface for PS-b-PMMA can be provided by hydrogen-terminated silicon. For example, the floors **20**" of trenches **14b**" can be masked, e.g., using a patterned photoresist layer **24**", and the floors **20**" of trenches **14a**", **14c**" can be selectively etched (arrows ↓↓↓), for example, with a hydrogen plasma, to remove the oxide material and form hydrogen-terminated silicon **22**", which is neutral wetting with equal affinity for both blocks of a block copolymer material such as PS-b-PMMA. H-terminated silicon can be prepared by a conventional process, for example, by a fluoride ion etch of a silicon substrate (with native oxide present, about 12-15 Å) by exposure to an aqueous solution of hydrogen fluoride (HF) and buffered HF or ammonium fluoride (NH₄F), by HF vapor treatment, or by a hydrogen plasma treatment (e.g., atomic hydrogen). The photoresist layer **24**" can then be removed, resulting in a structure as shown in FIGS. **3-3B**.

[0039] In other embodiments, a neutral wetting layer (**22**) can be provided by grafting a random copolymer such as PS-r-PMMA selectively onto an H-terminated silicon substrate (e.g., **20**" floor) in FIGS. **10-10B** by an in situ free radical polymerization of styrene and methyl methacrylate using a di-olefinic linker such divinyl benzene which links the polymer to the surface to produce an about 10-15 nm thick film.

[0040] In other embodiments, a layer of a preferential wetting material can be applied onto the surface of the substrate exposed as the floors of trenches **14b**. For example, a layer of oxide or silicon nitride, etc. can be deposited as a blanket

layer into the trenches (e.g., as shown in FIGS. **7-7B**), followed by selective removal of the material from the floor of trenches **14a**", **14c**" to expose a neutral wetting surface or, in other embodiments, a neutral wetting material (e.g., a random copolymer) can then be selectively applied onto the exposed floors of trenches **14a**", **14c**".

[0041] In yet another embodiment, the floors of the trenches can be made neutral or preferential wetting by varying the roughness of the surface of the trenches floor, as described, for example, in Sivaniah et al., *Macromolecules* 2005, 38, 1837-1849, and Sivaniah et al., *Macromolecules* 2003, 36, 5894-5896, the disclosure of which are incorporated by reference herein. A grooved or periodic grating-like substrate topography having a lateral periodicity and structure at or above a critical roughness value (e.g., $q_s R$ where $q_s = 2\pi/\lambda_s$, R is the (root-mean-square) vertical displacement of the surface topography about a mean horizontal plane, and λ_s is the lateral periodicity in the surface topography) can be provided to form a neutral wetting surface (e.g., trenches **14a**, **14c**) for formation of perpendicular cylinders (under conditions of a neutral wetting air surface). The floors of trenches **14b** can be provided with a low surface roughness below the critical $q_s R$ value for formation of parallel-oriented half-cylinders in those trenches. The critical roughness of the floor surface topography can also be adjusted according to the molecular weight of the block copolymer to achieve a perpendicular orientation of cylinders. The roughness of the substrate surface can be characterized using atomic force microscopy (AFM).

[0042] For example, as shown in FIGS. **11-11B**, in some embodiments, the floors of trenches **14a**", **14c**" can be selectively etched (arrows ↓↓↓) to provide a pattern of grooves **26**" at or above a critical roughness ($q_s R$), the floors being sufficiently rough to form a neutral wetting surface to induce formation of perpendicular-oriented cylinders within those trenches. In other embodiments, a material **26**" such as indium tin oxide (ITO), can be e-beam deposited (arrows ↓↓↓) onto the surface of floors **20**" of trenches **14a**", **14c**" to form a sufficiently rough and neutral wetting surface and, in some embodiments, sputter coated onto the surface of floors **20**" of trenches **14b**" to form a relatively smooth and preferential wetting surface.

[0043] Referring now to FIGS. **3-3B**, the sidewalls **16** and ends **18** of the trenches are preferential wetting by one block of the copolymer. The material layer **12** defining the trench surfaces can be an inherently preferential wetting material, or in other embodiments, a layer of a preferential wetting material can be applied onto the surfaces of the trenches. For example, in the use of a PS-b-PMMA block copolymer, the material layer **12** can be composed of silicon (with native oxide), oxide (e.g., silicon oxide, SiO₂), silicon nitride, silicon oxycarbide, ITO, silicon oxynitride, and resist materials such as methacrylate-based resists, among other materials, which exhibit preferential wetting toward the PMMA block. In other embodiments, a layer of a preferential wetting material such as a polymethylmethacrylate (PMMA) polymer modified with an —OH containing moiety (e.g., hydroxyethylmethacrylate) can be applied onto the surfaces of the trenches, for example, by spin coating and then heating (e.g., to about 170° C.) to allow the terminal OH groups to end-graft to oxide sidewalls **16** and ends **18** of the trenches. Non-grafted material can be removed by rinsing with an appropriate solvent (e.g., toluene). See, for example, Mansky

et al., *Science*, 1997, 275, 1458-1460, and In et al., *Langmuir*, 2006, 22, 7855-7860, the disclosures of which are incorporated by reference herein.

[0044] Referring now to FIGS. 12-12B, a cylindrical-phase self-assembling block copolymer material **28** having an inherent pitch at or about L_o (or a ternary blend of block copolymer and homopolymers blended to have a pitch at or about L_o) is then deposited, typically by spin casting or spin-coating into the trenches **14a-14c** and onto the floors **20**. The block copolymer material can be deposited onto the patterned surface by spin casting from a dilute solution (e.g., about 0.25-2 wt % solution) of the copolymer in an organic solvent such as dichloroethane (CH_2Cl_2) or toluene, for example.

[0045] The copolymer material layer **28** is deposited into the trenches **14a-14c** to a thickness (t) such that during an anneal, the capillary forces pull excess material (e.g., greater than a monolayer) into the trench. The resulting thickness of layer **28** in the trench is at about the L_o value of the copolymer material such that the copolymer film layer will self assemble upon annealing to form an array of cylindrical elements, for example, perpendicular cylindrical domains having a diameter at or about $0.5 L_o$ (e.g., about 20 nm) over the neutral wetting surface **22** of trenches **14a, 14c**, and a single layer of lines of parallel-oriented half-cylinders with a diameter at or about $0.5 L_o$ over the preferential wetting floor **20** of trenches **14b**. The film thickness can be measured, for example, by ellipsometry. Depending on the depth (D_t) of the trenches, the cast block copolymer material **28** can fill the trenches where the trench depth is about equal to L_o ($D_t \sim L_o$), or form a thinner film over the trench floor where the trench depth (D_t) is greater than L_o ($D_t > L_o$) as depicted. A thin film of the copolymer material **28** generally less than L_o can be deposited on the spacers **12a**, this material will not self-assemble, as it is not thick enough to form structures.

[0046] Although diblock copolymers are used in the illustrative embodiment, other types of block copolymers (i.e., triblock or triblock or multiblock copolymers) can be used. Examples of diblock copolymers include polystyrene-block-methyl methacrylate (PS-b-PMMA), polyethyleneoxide-polyisoprene, polyethyleneoxide-polybutadiene, polyethyleneoxide-polystyrene, polyethyleneoxide-polymethylmethacrylate, polystyrene-polyvinylpyridine, polystyrene-polyisoprene (PS-b-PI), polystyrene-polybutadiene, polybutadiene-polyvinylpyridine, and polyisoprene-polymethylmethacrylate, among others. Examples of triblock copolymers include poly(styrene-block methyl methacrylate-block-ethylene oxide). An example of a PS-b-PMMA copolymer material ($L_o = 35$ nm) is composed of about 70% PS and 30% PMMA with a total molecular weight (M_n) of 67 kg/mol, to form ~20 nm diameter cylindrical PMMA domains in a matrix of PS.

[0047] The block copolymer material can also be formulated as a binary or ternary blend comprising a SA block copolymer and one or more homopolymers of the same type of polymers as the polymer blocks in the block copolymer, to produce blends that swell the size of the polymer domains and increase the L_o value of the polymer. The volume fraction of the homopolymers can range from 0 to about 40%. An example of a ternary diblock copolymer blend is a PS-b-PMMA/PS/PMMA blend, for example, 46K/21K PS-b-PMMA containing 40% 20K polystyrene and 20K poly(methylmethacrylate). The L_o value of the polymer can also be modified by adjusting the molecular weight of the block copolymer.

[0048] Optionally, ellipticity ("bulging") can be induced in the structures by creating a slight mismatch between the trench and the spacer widths and the inherent pitch (L_o) of the block copolymer or ternary blend, as described, for example, by Cheng et al., "Self-assembled One-Dimensional Nanostructure Arrays," *Nano Lett.*, 6 (9), 2099-2103 (2006), which then reduces the stresses that result from such mismatches.

[0049] Referring now to FIGS. 13-13B, the block copolymer film **28** is then annealed to cause the component polymer blocks to phase separate and self assemble according to the wetting material on the trench floors **20** and the preferential wetting surfaces of the trench sidewalls **16** and ends **18**. This imposes ordering on the block copolymer film as it is annealed and the blocks self-assemble, resulting in a 1-D array of perpendicular-oriented cylinders **30** (minority block) in a matrix **34** (majority block) for the length (nL_o) of each trench **14a** (neutral wetting floor), parallel-oriented half-cylinder(s) **32** in a matrix **34** for the length of each trench **14b**, and a hexagonal close pack array of perpendicular cylinders **30** in trench **14c**. A layer **30a, 32a** of the minority block wets the preferential wetting sidewalls **16** and ends **18** of the trenches.

[0050] The copolymer film can be thermally annealed to above the glass transition temperature of the component blocks of the copolymer material. For example, a PS-b-PMMA copolymer film can be annealed at a temperature of about 180-285° C. in a vacuum oven for about 1-24 hours to achieve the self-assembled morphology. The resulting morphologies of the block copolymer (i.e., perpendicular and parallel orientation of cylinders) can be examined, for example, using atomic force microscopy (AFM), transmission electron microscopy (TEM), and scanning electron microscopy (SEM).

[0051] The diameter of the perpendicular cylinders **30** and width of the half-cylinders **32** is generally about $0.5 L_o$ (e.g., about 20 nm). The center-to-center distance (pitch distance, p) between adjacent cylindrical domains within a trench is generally at or about L_o (e.g., about 40 nm for a 46/21 PS/PMMA block copolymer).

[0052] The hexagonal array of perpendicular cylinders **30** in trench **14c** contains n rows of cylinders according to the width (w_t) of the trench with the cylinders in each row being offset by about L_o (pitch distance (p) or center-to-center distance) from the cylinders in the adjacent rows. Each row contains " m " number of cylinders according to the length (l_t) of the trench and the shape of the trench ends **18** (e.g., rounded, angled, etc.), with some rows having greater or less than m cylinders. The perpendicular cylinders **30** are spaced apart at a pitch distance (p) at or about L_o between cylinders in the same row and an adjacent row, and at a pitch distance (p) at or about $L_o \cdot \cos(\pi/6)$ or about $0.866 \cdot L_o$ distance between two parallel lines where one line bisects the cylinders in a given row and the other line bisects the cylinders in an adjacent row.

[0053] The annealed and ordered film may then be treated to crosslink the polymer segments (e.g., the PS matrix **34**) to fix and enhance the strength of the self-assembled polymer blocks within the trenches. The polymers can be structured to inherently crosslink (e.g., upon exposure to ultraviolet (UV) radiation, including deep ultraviolet (DUV) radiation), or one or both of the polymer blocks of the copolymer material can

be formulated to contain a crosslinking agent. Non-ordered material outside the trenches (e.g., on spacers 12a) may then be removed.

[0054] For example, in one embodiment, the trench regions can be selectively exposed through a reticle (not shown) to crosslink only the self-assembled films within the trenches, and optionally, a wash can then be applied with an appropriate solvent (e.g., toluene) to remove non-crosslinked portions of the film 28 (e.g., on the spacers 12a). In another embodiment, the annealed films can be crosslinked globally, a photoresist layer can be applied to pattern and expose the areas of the film outside the trench regions (e.g., over the spacers 12a), and the exposed portions of the film can be removed, for example by an oxygen (O₂) plasma treatment. In other embodiments, the spacers 12a are narrow in width, for example, a width (w_s) of one of the copolymer domains (e.g., about L_o) such that the non-crosslinked block copolymer material 28 on the spacers is minimal and no removal is required. Material on the spacers 12a that is generally featureless need not be removed.

[0055] After annealing and the copolymer material is ordered, the minority polymer domains can be selectively removed from the films to produce a template for use in patterning the substrate 10. For example, as shown in FIGS. 14-14B, selective removal of the cylindrical domains 30, 32 (e.g., of PMMA) will produce an array of openings 36, 38 within the polymer matrix 34 (e.g., of PS), with the openings varying according to the orientation of the cylindrical domains within the trenches. Only openings 36 will extend to the trench floors 20, with the majority block matrix component 34 (e.g., PS) remaining underneath the lines of half-cylinder openings 38.

[0056] As shown in FIGS. 15A-15B, the half-cylinder openings 38 can be extended to expose the underlying substrate 10 by removing the underlying matrix component 34 (e.g., PS), for example, by a plasma O₂ etch. The cylindrical openings 36 generally have a diameter of about 5-50 nm and an aspect ratio of about 1:1 to about 1:2, and the lined openings (grooves) 38 have a width of about 5-50 nm and an aspect ratio of about 1:1. The resulting film 40 can then be used in patterning (arrows ↓↓) the substrate 10 to form a configuration of cylindrical openings 42 and grooves (lines) 44 (shown in phantom) extending to active areas or elements 46. The residual matrix 34 (film 40) can be removed and the openings 42, 44 filled with a material 48 e.g., a metal or conductive alloy such as Cu, Al, W, Si, and Ti₃ N₄, among others, as shown in FIGS. 16-16B to form arrays of cylindrical contacts 50 and parallel conductive lines 52, for example, to an underlying active area, contact, or conductive line 46. The cylindrical openings 42 can also be filled with a metal-insulator-metal-stack to form capacitors with an insulating material such as SiO₂, Al₂O₃, HfO₂, ZrO₂, SrTiO₃, and the like. Further processing can be conducted as desired.

[0057] Methods of the disclosure provide a means of generating self-assembled diblock copolymer structures where perpendicular cylinders preferentially form on some regions on a substrate and parallel cylinders form on other regions. In some embodiments, the desired orientation is controlled by the structure of the substrate (e.g., wafer) and/or the nature of the surface material. The methods provide ordered and registered elements on a nanometer scale that can be prepared more inexpensively than by electron beam lithography or EUV photolithography. The feature sizes produced and accessible by this invention cannot be prepared by conventional photolithography. Embodiments of the invention can

be used to pattern lines and openings (holes) on a substrate in the same patterning step, thus eliminating processing steps compared to conventional process flows. The described methods can be readily employed and incorporated into existing semiconductor manufacturing process flows.

[0058] Although specific embodiments have been illustrated and described herein, it will be appreciated by those of ordinary skill in the art that any arrangement which is calculated to achieve the same purpose may be substituted for the specific embodiments shown. This application is intended to cover any adaptations or variations that operate according to the principles of the invention as described. Therefore, it is intended that this invention be limited only by the claims and the equivalents thereof. The disclosures of patents, references and publications cited in the application are incorporated by reference herein.

What is claimed is:

1. A self-assembled block copolymer film within a plurality of trenches in a substrate, the film in a first trench comprising perpendicular cylinders and the film in a second trench comprising parallel-oriented half-cylinders.

2. The film of claim 1, wherein the film in the first trench comprises a hexagonal array of perpendicular cylinders.

3. The film of claim 2, wherein ends of the first trench are curved.

4. The film of claim 1, wherein the film in the first trench comprises a single row of perpendicular cylinders extending the length of the trench.

5. The film of claim 1, wherein the cylinders and half-cylinders comprise a minority block of the block copolymer in a matrix of a majority block.

6. The film of claim 1, wherein the first trench has a width of about 1.5*L_o to about 2*L_o.

7. The film of claim 1, wherein the second trench has a width of about L_o or about n*L_o where n is an integer of 3 or greater.

8. The film of claim 1, further comprising the film in a third trench comprising perpendicular cylinders, wherein the first trench has a width of about 1.5*L_o to about 2*L_o, and the third trench has a width of about L_o or about n*L_o where n is an integer of 3 or greater.

9. The film of claim 1, wherein each of the first trench and the second trench has a width of about n*L_o, wherein n is an integer of 3 or greater.

10. The film of claim 1, wherein at least one of the first trench and the second trench has a width at or about L_o.

11. The film of claim 1, wherein the film is crosslinked.

12. A self-assembled block copolymer film within an array of trenches in a substrate, each trench having sidewalls, a width and a length, the film in a first trench comprising perpendicularly-oriented cylindrical domains of a minority block of the block copolymer in a matrix of a majority block and the film in a second trench comprising parallel-oriented half-cylindrical domains of the minority block in a matrix of the majority block.

13. The film of claim 12, wherein the sidewalls and ends of the trenches comprise a material that is preferential wetting to the minority block of the block copolymer, the floor of the first trench comprises a material that is neutral wetting to both the minority and majority blocks of the block copolymer, and the floor of the second trench comprises a material that is preferential wetting to the minority block of the block copolymer.

14. The film of claim **13**, wherein the preferential wetting material is selected from the group consisting of silicon (with native oxide), oxide, silicon nitride, silicon oxycarbide, silicon oxynitride, indium tin oxide, and methacrylate-based resists.

15. The film of claim **13**, wherein the floor of at least one of the trenches has a surface roughness for preferential wetting or neutral wetting of the blocks of the block copolymer.

16. The film of claim **15**, wherein said floor comprises grooves in a lateral periodicity.

17. The film of claim **15**, wherein the floor of the first trench comprises a material having a surface roughness at or above a critical roughness for neutral wetting of the minority block of the block copolymer.

18. The film of claim **15**, wherein the floor of the second trench comprises a material having a surface roughness below a critical roughness for preferential wetting of the minority block of the block copolymer.

19. A self-assembled block copolymer film within an array of trenches in a substrate, the film in a first trench comprising perpendicular-oriented cylinders in a single row extending the length of said first trench, the film in a second trench comprising perpendicular-oriented cylinders in a hexagonal array, and the film in a third trench comprising parallel-oriented half-cylinders extending the length of said third trench.

20. A template for etching a substrate, the template comprising openings extending through a polymer matrix situated within an array of trenches, each trench having sidewalls, opposing ends, a floor, a width and a length, the polymer matrix in a first trench comprising a plurality of perpendicular cylindrical openings separated at a pitch distance of about L_0 ,

and the polymer matrix in a second trench comprising a plurality of linear openings extending the length of the second trench and separated at a pitch distance of about L_0 .

21. The template of claim **20**, wherein the perpendicular cylindrical openings in the matrix in the first trench are in a hexagonal array.

22. The template of claim **21**, wherein the ends of the first trench are rounded.

23. The template of claim **21**, wherein the width of the first trench is about L_0 or about $n \cdot L_0$ where n is an integer of 3 or greater.

24. The template of claim **20**, wherein the perpendicular cylindrical openings are in a single line extending the length of the first trench.

25. The template of claim **24**, wherein the width of the first trench is about $1.5 \cdot L_0$ to about $2 \cdot L_0$.

26. The template of claim **20**, wherein the openings extend through the polymer matrix to the floor of the trench.

27. The template of claim **20**, wherein the polymer matrix is crosslinked and comprises a majority block of a self-assembled block copolymer.

28. A template for etching a substrate, the template comprising a plurality of openings extending through a polymer matrix of a majority block of a self-assembled block copolymer film within a plurality of trenches, each trench having sidewalls, opposing ends, a floor, a width and a length, the polymer matrix in a first trench comprising a plurality of perpendicular cylindrical openings separated at a pitch distance of about L_0 , and the polymer matrix in a second trench comprising a plurality of linear openings extending the length of the trench and separated at a pitch distance of about L_0 .

* * * * *