

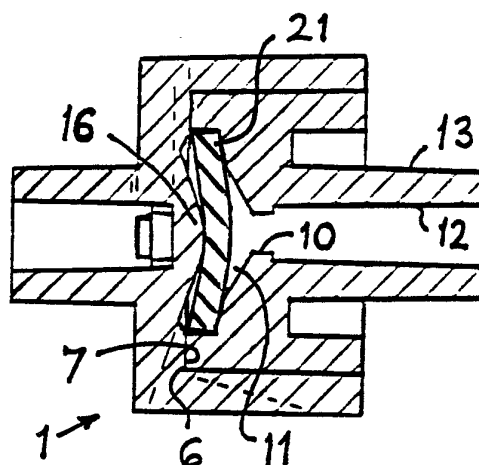

## INTERNATIONAL APPLICATION PUBLISHED UNDER THE PATENT COOPERATION TREATY (PCT)

(51) International Patent Classification <sup>5</sup> :  F16K 15/14	A1	(11) International Publication Number: <b>WO 92/12371</b>  (43) International Publication Date: 23 July 1992 (23.07.92)
<p>(21) International Application Number: PCT/GB92/00039</p> <p>(22) International Filing Date: 8 January 1992 (08.01.92)</p> <p>(30) Priority data: 9100298.0 8 January 1991 (08.01.91) GB</p> <p>(71) Applicant (for all designated States except US): DENLEY INSTRUMENTS LIMITED [GB/GB]; Natts Lane, Billingshurst, Sussex RH14 9EY (GB).</p> <p>(72) Inventor; and (75) Inventor/Applicant (for US only): COUPE, Neville, Burton [GB/GB]; Codmore Gardens, Hill Farm Lane, Pulborough, West Sussex RH20 1BJ (GB).</p> <p>(74) Agents: WARREN, Keith, Stanley et al.; Baron &amp; Warren, 18 South End, Kensington, London W8 5BU (GB).</p>		<p>(81) Designated States: AT, AT (European patent), AU, BB, BE (European patent), BF (OAPI patent), BG, BJ (OAPI patent), BR, CA, CF (OAPI patent), CG (OAPI patent), CH, CH (European patent), CI (OAPI patent), CM (OAPI patent), CS, DE, DE (European patent), DK, DK (European patent), ES, ES (European patent), FI, FR (European patent), GA (OAPI patent), GB, GB (European patent), GN (OAPI patent), GR (European patent), HU, IT (European patent), JP, KP, KR, LK, LU, LU (European patent), MC (European patent), MG, ML (OAPI patent), MN, MR (OAPI patent), MW, NL, NL (European patent), NO, PL, RO, RU, SD, SE, SE (European patent), SN (OAPI patent), TD (OAPI patent), TG (OAPI patent), US.</p> <p><b>Published</b> <i>With international search report.</i></p>

(54) Title: NON-RETURN VALVE



## (57) Abstract

A non-return valve comprises a narrow annular valve seat which is disposed between an inlet port (10) and an outlet port of the valve and has a dished configuration converging towards the inlet port (10). A resilient valve disc (21) is arranged to have an annular peripheral zone engaged with the valve seat and a bridge piece (16) spanning the outlet port bears on a central zone of the juxtaposed face of the valve disc (21) to depress the central zone and urge the valve disc into contact with the valve seat. The bridge piece (16) restrains the peripheral zone of the valve disc from being flexed out of engagement with the valve seat, thereby to permit fluid to flow through the valve, unless the differential fluid pressure between the inlet and outlet ports exceeds a desired minimum pressure differential.

**FOR THE PURPOSES OF INFORMATION ONLY**

Codes used to identify States party to the PCT on the front pages of pamphlets publishing international applications under the PCT.

AT	Austria	ES	Spain	MG	Madagascar
AU	Australia	FI	Finland	ML	Mali
BB	Barbados	FR	France	MN	Mongolia
BE	Belgium	GA	Gabon	MR	Mauritania
BF	Burkina Faso	GB	United Kingdom	MW	Malawi
BG	Bulgaria	GN	Guinea	NL	Netherlands
BJ	Benin	GR	Greece	NO	Norway
BR	Brazil	HU	Hungary	PL	Poland
CA	Canada	IT	Italy	RO	Romania
CF	Central African Republic	JP	Japan	RU	Russian Federation
CG	Congo	KP	Democratic People's Republic of Korea	SD	Sudan
CH	Switzerland	KR	Republic of Korea	SE	Sweden
CI	Côte d'Ivoire	LI	Lichtenstein	SN	Senegal
CM	Cameroon	LK	Sri Lanka	SU	Soviet Union
CS	Czechoslovakia	LU	Luxembourg	TD	Chad
DE	Germany	MC	Monaco	TG	Togo
DK	Denmark			US	United States of America

### NON-RETURN VALVE

The present invention relates to a non-return valve for controlling fluid flow and, more particularly, although not exclusively, to a miniature non-return valve for use in controlling the flow of liquid reagents in assay procedures and in other fluid flow applications where return or reverse flow is to be prevented.

In many applications, such as referred to above, it is often desirable to be able to set or predict the minimum fluid pressure or pressure differential at which a non-return valve will open and to ensure that this minimum opening pressure will remain substantially constant throughout the life of the valve. Accordingly, it is an object of the present invention to provide a non-return valve which is adapted to open and permit fluid flow through the valve only when the fluid pressure differential between the inlet and outlet of the valve exceeds a predetermined minimum pressure differential.

The invention consists in a non-return valve comprising an annular valve seat disposed between inlet and outlet ports of the valve, a resilient valve disc having one face engageable with the valve seat, and a protuberance bearing on a central zone of the opposite face of the valve disc so as to depress the central zone and urge the valve disc into contact with the valve seat.

With the present invention, the protuberance may be arranged so as to prevent the peripheral zone of the valve disc from being flexed out of engagement with the valve seat, thereby to permit fluid flow through the valve, unless the differential fluid pressure between the inlet and outlet ports exceeds a desired minimum pressure differential, and the valve may be constructed so that this minimum opening pressure differential remains substantially constant and predictable throughout the life of the valve.

Preferably, the annular valve seat is inclined and converges towards the inlet port. For example, it may have a dished configuration which is conveniently of part-spher-

ical shape. Alternatively, it may have a frusto-conical configuration with a relatively shallow angle of conveyance. In either case, a shallow inclination enables the amount of depression of the central zone of the valve disc, required to achieve a desired opening pressure, to be minimised. Preferably, the annular valve seat is connected to the inlet port via a frusto-conical section having a steeper angle of convergence than the average angle of inclination of the valve seat, for example, having an included angle of about  $120^\circ$ .

Conveniently, the protuberance comprises a bridge piece spanning the outlet port and having a central portion engaging the central zone of the valve disc to depress the latter. When the inlet pressure exceeds the predetermined minimum opening pressure with respect to the outlet pressure, the portions of the valve disc on opposite sides of the bridge piece flex away from the valve seat about an axis parallel to the bridge piece to permit flow through the valve.

The bridge piece may, for example, be of arcuate shape having a convex surface adjacent the valve disc which engages the central zone of the valve disc. The outlet port may have a frusto-conical lead-in section adjacent the valve disc and the bridge piece may extend substantially across the full width of this frusto-conical section.

In a preferred embodiment of the invention, the valve has a two-part body, one part containing the valve seat and inlet port and the other part containing the protuberance and outlet port. The valve seat is disposed at the base of a recess in a face of its associated part disposed adjacent the outlet port in the other part, the arrangement being such that the valve disc is trapped in the recess when the two body parts are assembled together. The two parts may be assembled together by arranging one of the parts to be an interference fit within a cavity formed in the other part.

One or both ports may each be connected to a hollow coupling spigot having internal and external tapers which

enable the valve to be connected to cooperating tubes or other items of equipment.

The two parts of the valve body may be moulded from plastics material, such as, polystyrene, polypropylene or polycarbonate and the valve disc may be formed from silicone rubber. Moulding the body parts of polycarbonate material enables the valve to be sterilised in an autoclave.

In order that the present invention may be more readily understood, reference will now be made by way of example to the accompanying drawings, in which:-

Figure 1 is an exploded axial section of a miniature valve embodying the invention,

Figure 2 is an axial section of the outlet body part of the valve taken along line II-II of Figure 1,

Figure 3 is an axial section of the assembled valve,

Figure 4 is a perspective view of the section shown in Figure 2; and

Figure 5 is an end view of the outlet body part of the valve taken in the direction of the arrow V in Figure 2.

Referring to the drawings, the valve has a two-part body 1 of generally cylindrical shape and comprising an inlet body part 2 and an outlet body part 3. The outlet body part 3 is formed with a cylindrical housing 4 defining a cylindrical cavity 5 and the inlet body part 2 is of cylindrical configuration and is an interference fit in the cavity 5 in the outlet body part 3. When the two parts 2,3 are assembled, mutually adjacent end faces 6,7 at the inner end of the inlet body part and at the bottom of the cavity 5 in the outlet body part are in abutting relation, as shown in Figure 3. Each body part is a one-piece moulding of plastics material, such as, polystyrene, polypropylene or polycarbonate.

Moulded coaxially in the inner end face 6 of the inlet body part 2 is a circular recess 8 which has a slightly inclined annular valve seat 9 formed in its base

and conveying towards an inlet port 10. In fact, the valve seat 9 has a shallow dished configuration of part spherical shape and is connected with the inlet port 10 by a frusto-conical passage 11 having a steeper angle than the average angle of inclination of the valve seat 9. The inlet port 10 communicates with a flow passageway 12 in a tubular coupling spigot 13 projecting coaxially from the inlet body part. This spigot has internally and externally tapered surfaces which permit the inlet side of the valve to be connected to a cooperating tube or other part by means of an internal or external interference fit. The inlet port 10 forms a constriction in the fluid flow passageway comprising the spigot passageway 12, the inlet port and the frusto-conical passageway 11.

The outlet body part 3 has an outlet port 14 arranged coaxially with the inlet port 10 and having a frusto-conical lead-in section 15 connecting the outlet port to the end face 7 at the bottom of the cavity 5. Spanning the lead-in section 15 and the outlet port 14 is an arcuate bridge piece 16 having a convex surface portion 17 projecting into the cavity 5. An opening 18 through the central part of the bridge piece provides a fluid flow passageway between the cavity 5 and the outlet port. The latter is connected to the internal passageway 19 of a tubular coupling spigot 20 projecting coaxially from the outlet body part. Similarly to the spigot 13 on the inlet part, the spigot 20 has internally and externally tapered surfaces to permit the outlet side of the valve to be connected to a cooperating part by means of an internal or external interference fit.

The valve includes a resilient valve disc 21, for example, formed from silicone rubber, which is fitted within the circular recess 8 in the inner end face 6 of the inlet part so that one face of the valve disc is engageable with the annular valve seat 9. When the body parts are assembled with the valve disc 21 housed in the recess 8, the bridge piece 16 serves as a protuberance and the central part of its convex surface 17 bears on the central

zone of the adjacent face of the valve disc 21 so as to depress this central zone and urge an annular peripheral zone of the opposite face into contact with the annular valve seat 9.

By way of example, in a miniature valve body 1 of approximately 9mm diameter, the dished configuration of the valve seat 9 may have a part-spherical shape of 9mm. radius whilst the frusto-conical passage 11 has an included or convergence angle of  $120^{\circ}$ . The dished or part-spherical shape of the valve seat closely conforms to the convex shape which is adopted by the juxtaposed surface of the valve disc 21 when the latter is depressed by the bridge piece 16 so that a narrow sealing zone is formed between the valve seat and the peripheral zone of the valve disc. Hence, the bridge piece positively urges the peripheral zone of the valve disc 21 into contact with the annular valve seat 9 and prevents this peripheral zone from being flexed out of engagement with the valve seat, thereby to permit fluid flow through the valve, unless the fluid pressure applied to the inlet port 10 exceeds that necessary to create a desired minimum pressure differential with respect to the outlet port, which is determined by the resiliency of the valve disc 21 and the degree to which the bridge piece 16 depresses the central zone of the latter. For example, these parameters may be adjusted so as only to permit the valve disc to open when the pressure differential exceeds a predetermined minimum pressure within the range 0.06 to 0.07kg/sq.cm (0.8 to 1lb/sq.in). When the pressure differential exceeds the predetermined minimum, the sectors of the valve disc on opposite sides of the bridge piece 16 flex away from the valve seat 9 about an axis parallel to the length of the bridge piece to permit flow through the valve. When the inlet pressure decreases so that the differential pressure is below the predetermined minimum, the inherent resiliency of the valve disc 21 reengages the valve disc with the valve seat so as to close the valve.

CLAIMS

1. A non-return valve comprising an annular valve seat (9) disposed between inlet and outlet ports (10,14) of the valve, and a protuberance (16) bearing on a central zone of the opposite face of the valve disc (21) so as to depress the central zone and urge the valve disc into contact with the valve seat (9).
2. A valve according to claim 1, wherein the annular valve seat (9) is inclined and converges towards the inlet port (10).
3. A valve according to claim 2, wherein the annular valve seat (9) has a dished or frusto-conical configuration.
4. A valve according to claim 2 or 3, wherein the annular valve seat (9) is connected to the inlet port (10) via frusto-conical section (11) having a steeper angle of convergence than the general inclination of the valve seat.
5. A valve according to any preceding claim, wherein the protuberance comprises a bridge piece (16) spanning the outlet port (14) and having a central portion (17) engaging the central zone of the valve disc (21) to depress the latter.
6. A valve according to claim 5, wherein the bridge piece (16) is of arcuate shape having a convex surface (17) adjacent the valve disc (9) which engages the central zone of the valve disc.
7. A valve according to any preceding claim, wherein the outlet port (14) has a frusto-conical lead-in section (15) adjacent the valve disc (21) and the bridge piece (16) extends substantially across the full width of said frusto-conical section.
8. A valve according to any preceding claim, comprising a two-part body (1), one part (2) having the valve seat (9) and inlet port (10) and the other part (3) having the protuberance (16) and the outlet port (14).
9. A valve according to claim 8, wherein the valve seat (9) is disposed at the base of a recess (8) in a face



(6) of its associated part (2) which face is disposed adjacent the outlet port (14) of the other part (3), the arrangement being such that the valve disc (21) is trapped in the recess (8) when the two body parts (2,3) are assembled together.

10. A valve according to claim 8 or 9, wherein the body parts (2,3) are assembled together by arranging one of the parts (2) to be an interference fit within a cavity (5) formed in the other part (3).

11. A valve according to any preceding claim, wherein one or each of the inlet and outlet ports (10,14) is connected to a hollow coupling spigot (13,20) having internal and external tapers which enable the valve to be connected to cooperating tubes or other items of equipment.

12. A valve according to any preceding claim, wherein the body parts (2,3) are moulded from plastics material, such as polystyrene, polypropylene or polycarbonate, and the valve disc (21) is formed from silicon rubber.

13. A valve according to any preceding claim, wherein the resiliency of the valve disc (21) and the degree to which the protuberance (16) depresses the central zone of the valve disc are selected to achieve the desired minimum pressure differential at which the valve opens.

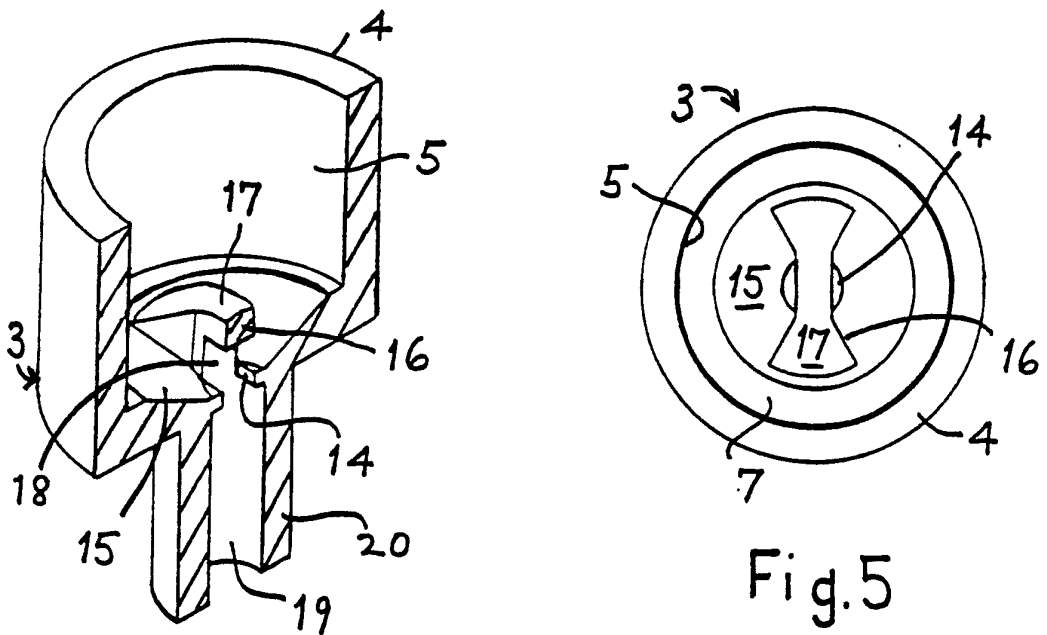
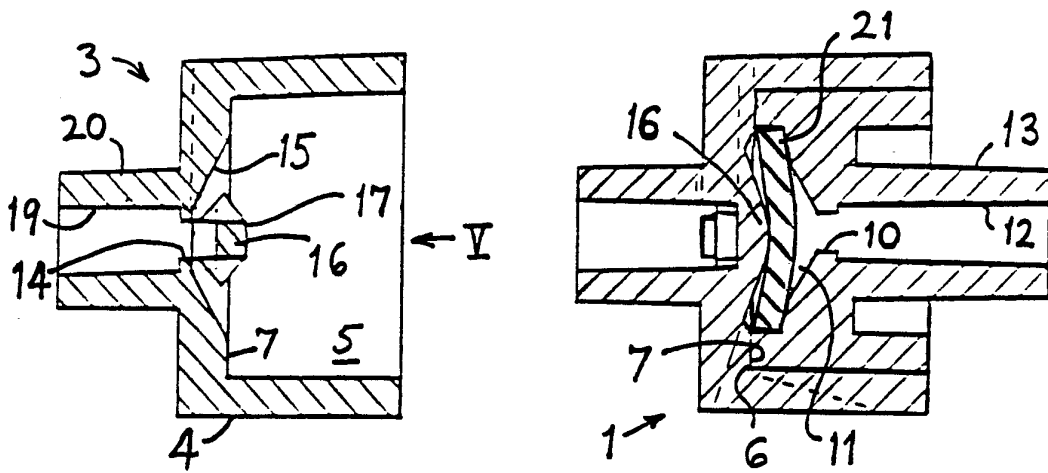
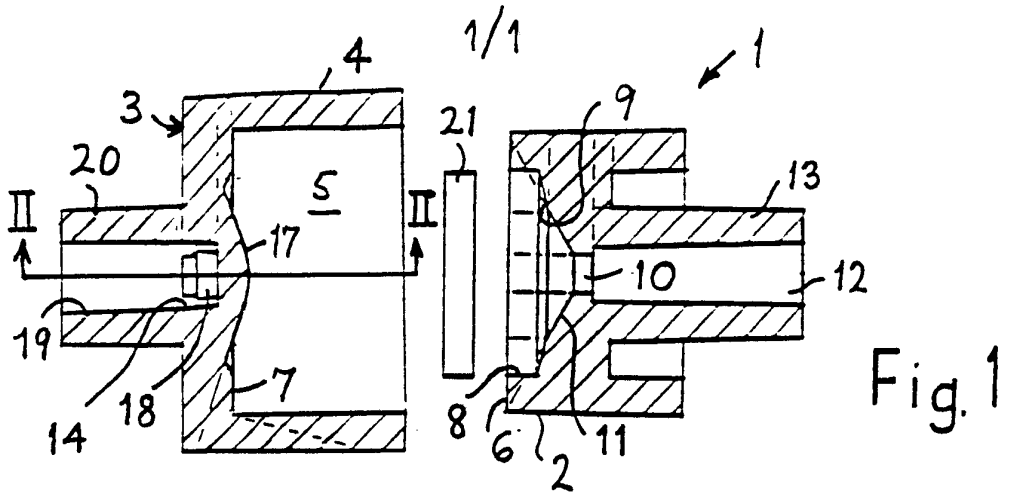

# INTERNATIONAL SEARCH REPORT

International Application No PCT/GB 92/00039

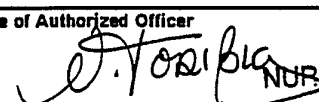
<b>I. CLASSIFICATION OF SUBJECT MATTER</b> (If several classification symbols apply, indicate all) <sup>6</sup>		
According to International Patent Classification (IPC) or to both National Classification and IPC		
IPC5: F 16 K 15/14		
<b>II. FIELDS SEARCHED</b>		
Minimum Documentation Searched <sup>7</sup>		
Classification System	Classification Symbols	
IPC5	F 16 K	
Documentation Searched other than Minimum Documentation to the extent that such Documents are included in Fields Searched <sup>8</sup>		
<b>III. DOCUMENTS CONSIDERED TO BE RELEVANT<sup>9</sup></b>		
Category *	Citation of Document, <sup>11</sup> with indication, where appropriate, of the relevant passages <sup>12</sup>	Relevant to Claim No. <sup>13</sup>
X	US, A, 4749003 (LEASON) 7 June 1988, see the whole document  --	1-13
X	US, A, 4762149 (PICKL, JR.) 9 August 1988, see the whole document  --	1-13
X	EP, A2, 0129410 (ILLINOIS TOOL WORKS INC.) 27 December 1984, see the whole document  --  -----	1-13
<p>* Special categories of cited documents:<sup>10</sup></p> <p>"A" document defining the general state of the art which is not considered to be of particular relevance</p> <p>"E" earlier document but published on or after the international filing date</p> <p>"L" document which may throw doubts on priority claim(s) or which is cited to establish the publication date of another citation or other special reason (as specified)</p> <p>"O" document referring to an oral disclosure, use, exhibition or other means</p> <p>"P" document published prior to the international filing date but later than the priority date claimed</p> <p>"T" later document published after the international filing date or priority date and not in conflict with the application but cited to understand the principle or theory underlying the invention</p> <p>"X" document of particular relevance, the claimed invention cannot be considered novel or cannot be considered to involve an inventive step</p> <p>"Y" document of particular relevance, the claimed invention cannot be considered to involve an inventive step when the document is combined with one or more other such documents, such combination being obvious to a person skilled in the art.</p> <p>"&amp;" document member of the same patent family</p>		
<b>IV. CERTIFICATION</b>		
Date of the Actual Completion of the International Search	Date of Mailing of this International Search Report	
20th March 1992	15. 04. 92	
International Searching Authority	Signature of Authorized Officer	
EUROPEAN PATENT OFFICE	 NURIA TORIBIO	

**ANNEX TO THE INTERNATIONAL SEARCH REPORT  
ON INTERNATIONAL PATENT APPLICATION NO. PCT/GB 92/00039**

SA 55263

This annex lists the patent family members relating to the patent documents cited in the above-mentioned international search report. The members are as contained in the European Patent Office EDP file on 28/02/92. The European Patent office is in no way liable for these particulars which are merely given for the purpose of information.

Patent document cited in search report	Publication date	Patent family member(s)	Publication date
US-A- 4749003	07/06/88	EP-A- 0276556	03/08/88
US-A- 4762149	09/08/88	NONE	
EP-A2- 0129410	27/12/84	AU-D- 2599984	20/12/84
		CA-A- 1235978	03/05/88
		JP-A- 60004680	11/01/85
		US-A- 4765372	23/08/88

For more details about this annex: see Official Journal of the European patent Office, No. 12/82