



US 20060273525A1

(19) **United States**

(12) **Patent Application Publication**

Fiedler

(10) **Pub. No.: US 2006/0273525 A1**

(43) **Pub. Date:**

Dec. 7, 2006

(54) **MULTIPART OIL WIPING RING FOR PISTONS OF INTERNAL COMBUSTION ENGINES**

Publication Classification

(51) **Int. Cl.**
F16J 9/00 (2006.01)

(52) **U.S. Cl.** 277/434

(76) **Inventor: Rolf-Gerhard Fiedler, Wendlingen (DE)**

(57) **ABSTRACT**

The invention relates to a multipart oil wiping ring for pistons of internal combustion engines, comprising two steel strip-type lamellae with parallel sides, the running surfaces of which are provided with a convexly asymmetric shape having a vertex line that extends across the circumference of the lamellae, and a bracing spring located between the lamellae, said bracing spring pressing the lamellae in an axial direction against one respective side of an annular groove in the piston and in a radial direction against the cylinder wall. The aim of the invention is to obtain an oil-wiping effect that is improved compared to prior art while reducing wear of the running surface. Said aim is achieved by configuring the running surfaces (h, h') of both lamellae so as to make the same correspond to a final contour approaching a condition of wear in the run-in state of the engine, the vertex lines (3, 3') of the running surfaces (h, h') being oriented counter to the direction of the center of the annular groove (3) in the mounted states of the oil ring (10) in the piston.

Correspondence Address:
**WILLIAM COLLARD
COLLARD & ROE, P.C.
1077 NORTHERN BOULEVARD
ROSLYN, NY 11576 (US)**

(21) **Appl. No.: 10/570,103**

(22) **PCT Filed: Sep. 1, 2004**

(86) **PCT No.: PCT/DE04/01939**

(30) **Foreign Application Priority Data**

Sep. 2, 2003 (DE)..... 103 40 312.4

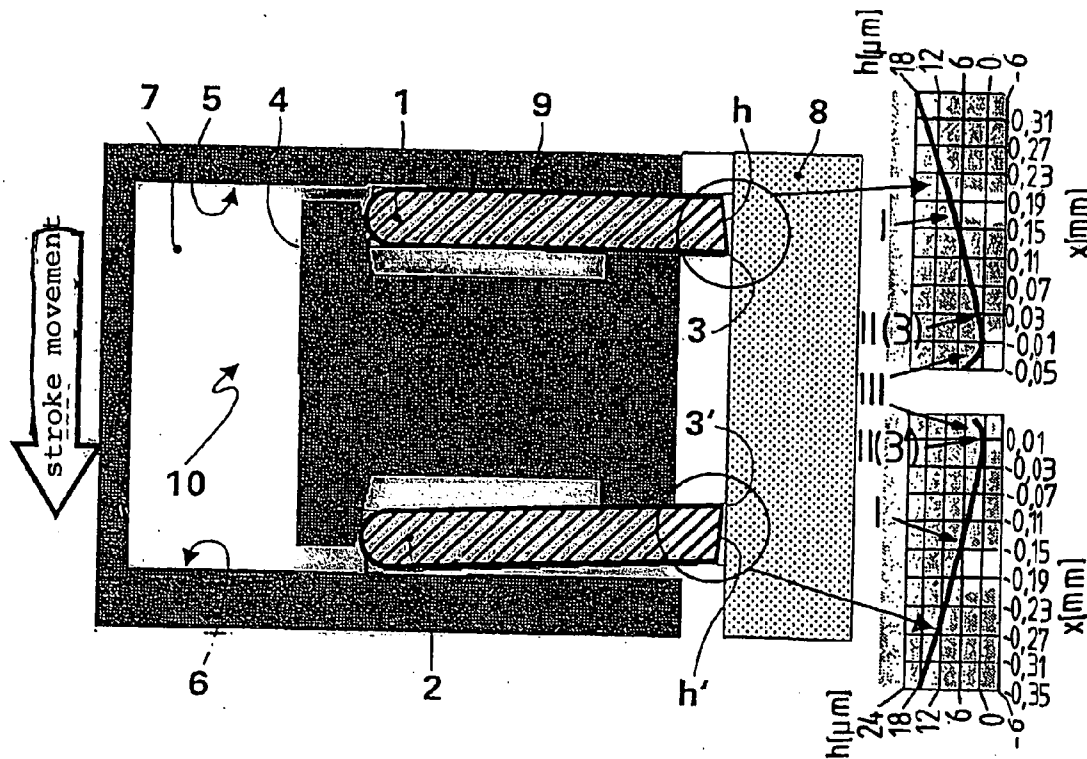

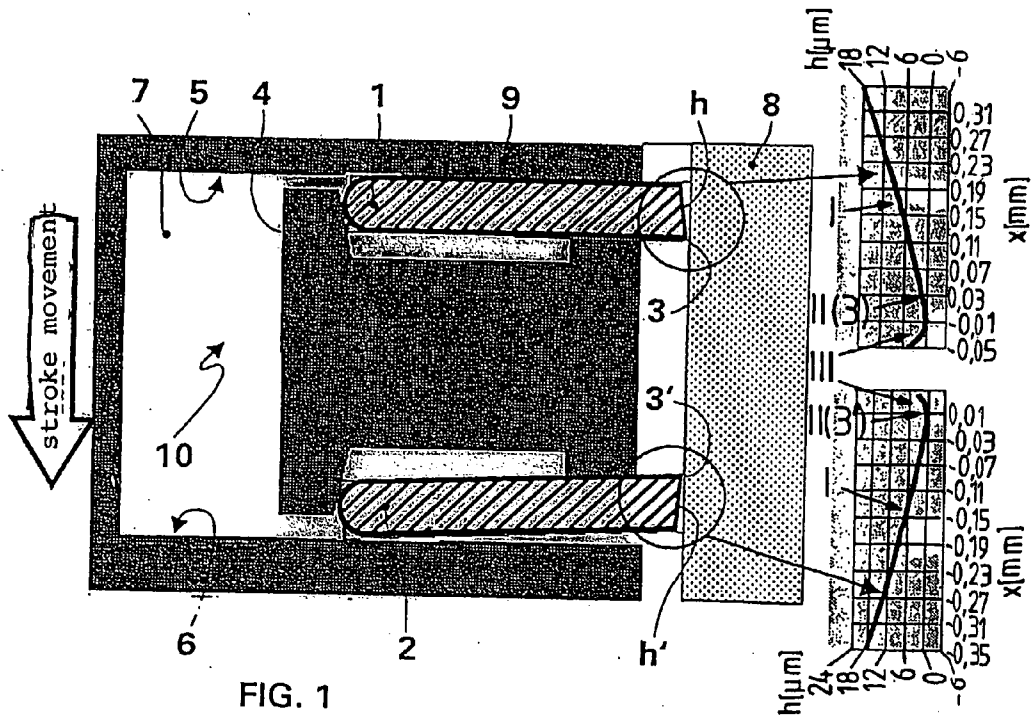

FIG. 1

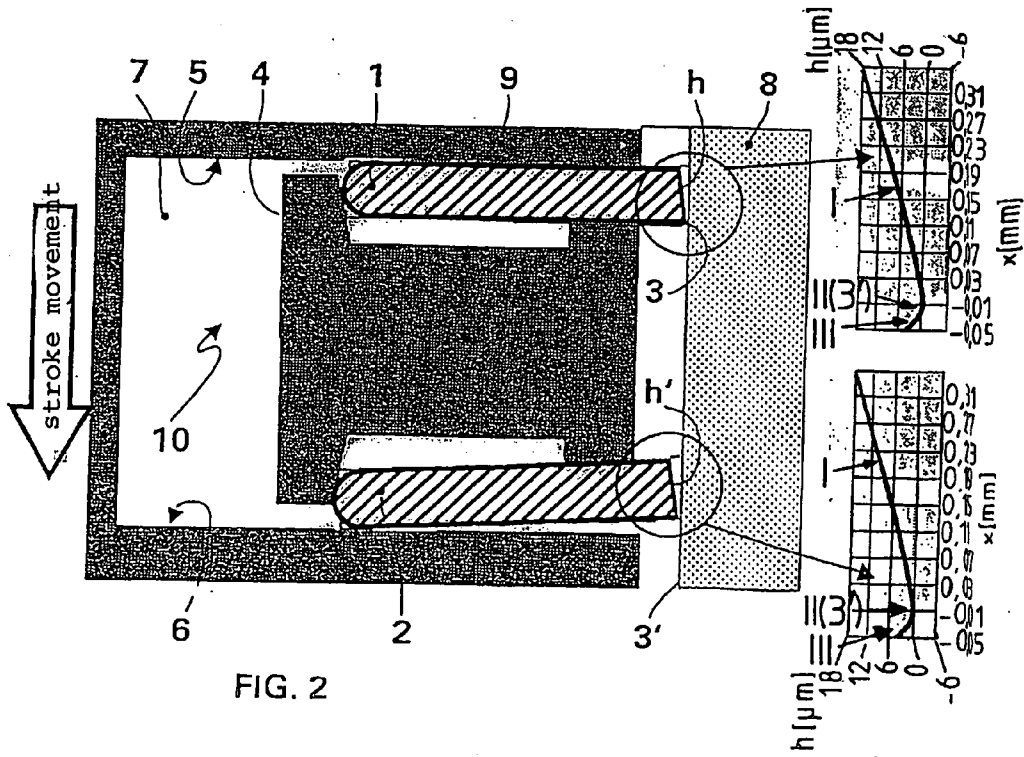

FIG. 2

MULTIPART OIL WIPING RING FOR PISTONS OF INTERNAL COMBUSTION ENGINES

[0001] The invention relates to a multi-part oil control ring for pistons of internal combustion engines, having two lamellae consisting of steel strips that have parallel walls, the working surfaces of which have a barrel-shaped asymmetrical shape, in each instance, having a vertex line that extends over the circumference of the lamellae, as well as having a spreading spring disposed between the lamellae, which presses the lamellae both axially against one of the walls of a ring groove in the piston, in each instance, and radially against the cylinder wall.

[0002] In order to prevent too much motor oil from getting into the combustion chamber, which not only results in high oil consumption but also has negative effects on the emission behavior of the engine, a sufficient tangential force of the oil control rings is required to produce a radial contact pressure against the cylinder wall and thereby a good oil control effect. However, this results in a high surface pressure against the working surfaces of the steel lamellae, and therefore a high friction power during engine operation. This friction power worsens the degree of effectiveness of the internal combustion engine and accordingly increases the fuel consumption. The design of the tangential force of the oil control rings is therefore always a compromise between minimal friction power and maximal oil control effect. All of the measures for reducing the friction power during engine operation, without reducing the tangential force, thereby facilitate the design of the oil control rings, i.e. improve the degree of effectiveness of the engine.

[0003] Accordingly, an attempt was made, for oil control rings of the type stated, not only to provide a special design of the spreading spring, but also to form the working surfaces of the lamellae in such a manner that these meet the aforementioned requirements. Among other things, working surfaces that run plane-parallel to the cylinder wall are known, as indicated in U.S. Pat. No. 3,738,668, as are working surface contours that are configured to be symmetrically barrel-shaped, as described in DE 36 38 728 A1. In this connection, multi-part oil control rings having symmetrically barrel-shaped working surfaces of the lamellae are mounted in the piston in any desired installation position, i.e. not oriented.

[0004] Asymmetrical working surfaces of oil control rings or piston rings are known from DE 38 33 322 A1, DE 43 00 531 C1, or DE 44 29 649 C2. These embodiments, however, relate only to individual rings, whereby information relating to possible installation positions with regard to multi-part oil control rings cannot be derived from the references.

[0005] It is the task of the invention to indicate a multi-part oil control ring for a piston of an internal combustion engine, which has an improved oil control effect as compared with the known state of the art, at a reduced wear of the working surface.

[0006] This task is accomplished in that the working surfaces of the two lamellae are configured in such a manner that they correspond to a final contour approaching a condition of wear in the run-in state of the engine, whereby the vertex lines of the working surfaces are oriented in the opposite direction to the center of the ring groove, in each instance, in the assembled state of the oil ring in the piston.

The working surfaces of the lamellae are characterized by an asymmetrical incline having a barrel shape that is greatly reduced as compared with the state of the art, whereby the working surface contour can be approximately described by means of a polynomial of the second order.

[0007] In another embodiment of the invention, the working surfaces of the lamellae are oriented in the same direction as the ring groove wall that faces away from the piston crown, in each instance, with their vertex lines.

[0008] By means of the working surface configuration according to the invention, and the arrangement of the lamellae relative to one another, a reduction in the friction power of the entire steel-band oil control ring is achieved, by means of a more advantageous hydrodynamic condition at one of the two lamellae, without any reduction in tangential force, whereby the oil-controlling function of the other lamella is maintained to its full extent, in this connection. The reduction in the friction power thereby results in an improvement of the degree of effectiveness of the engine, or the oil control behavior can be improved by means of an increase in the tangential force, with an unchanged friction power level.

[0009] Practical embodiments of the invention are the subject of the dependent claims.

[0010] An exemplary embodiment of the invention is described below, using the drawings. These show:

[0011] **FIG. 1** a cross-section of the oil control ring according to the invention, in a first embodiment, and

[0012] **FIG. 2** a cross-section of the oil control ring according to the invention, in a second embodiment.

[0013] As is evident from **FIG. 1**, a multi-part oil control ring **10** consists of two steel-band lamellae **1** and **2** and a spreading spring **4**, which presses the lamellae both axially against one of the walls **5** and **6** of the ring groove **7** in the piston, and radially against the cylinder wall **8**. The ring groove wall **5** represents the piston crown side, and the ring groove wall **6** represents the side facing away from the piston crown. According to the invention, the lamella **1** has a barrel-shaped asymmetrically shaped working surface **h** with a vertex line **3** that extends over the circumference of the lamella, and the lamella **2** has a barrel-shaped asymmetrical working surface **h'** with a vertex line **3'**, whereby the vertex lines **3, 3'**, in each instance, act as edges that stand in contact with the cylinder wall **8**, for oil control. In a first exemplary embodiment according to **FIG. 1**, the lamellae **1** and **2** are disposed relative to one another, in their assembled state, in such a manner that their vertex lines **3, 3'** (edges) are oriented in the direction of the center of the ring groove **7**, in each instance. According to **FIG. 1**, this lamella arrangement is supposed to be understood as being in opposite directions, whereas according to **FIG. 2**, the arrangement of the lamellae relative to one another is supposed to be understood as being in the same direction. In this exemplary embodiment, the two vertex lines **3, 3'** (edges) are disposed pointing away from the ring groove wall **5** on the piston crown side, between the spreading spring **4**.

[0014] According to the invention, the working surfaces **h** and **h'** of the lamellae have a shape that corresponds to a run-in process of several hundred hours of engine operation. This is characterized in that the working surfaces **h, h'** of the

two lamellae **1** and **2**, in cross-section, approximately follow the asymmetrical shape of a polynomial of the second order in a first segment (I), with $h(x)=ax+bx^2$, whereby x =working surface coordinates in the Cartesian coordinate system in mm, and a , b are coefficients, with a being defined by the ratio of the axial wall play of the lamellae relative to the width of the lamellae; b being defined as the amount of the working surface curvature; a supporting vertex (II) $h(x=0)$ configured as an edge, and in a third segment (III) approximately follows the asymmetrical shape of the function $h(x)=cx^2$, with c as a multiple of b . As an example for lamellae having a thickness of 0.4 mm, a value $h(x)=35x+50x^2$ is obtained. With this, the cross-section curves shown in accordance with **FIGS. 1 and 2** can be achieved, with x as the working surface coordinate in mm, and $h(x)$ as the barrel shape in μm . It is understandable that the coefficients of this polynomial must be coordinated with the specific application, whereby essential parameters in this connection are the cylinder diameter, the dimensions of the lamella cross-section, the configuration of the contact points on the spreading spring, and the axial play ratios of the steel-band oil control ring in the ring groove. The typical barrel shape of the working surfaces h and h' according to the invention amount to approximately 2 to 10 $\mu\text{m}/0.4$ mm as compared with embodiments according to the state of the art of 3 to 15 $\mu\text{m}/0.15$ mm.

[0015] Functionally, the oil control effect that is improved according to the invention results from the fact that the friction force that engages on the working surfaces h , h' of the lamellae in the cylinder axis direction generates a torque that causes the lamellae to arch in plate shape. This is possible because the configuration of the spreading spring **4** prevents a movement of the lamellae **1** and **2** in the axial direction, particularly on the inner contact point, whereas clearly greater axial movement amplitudes are possible at the outer contact point. The friction force, and therefore the torque, changes its sign as a function of the stroke direction of the piston. Since the amount of the friction force is still dependent on velocity, this results in a constant change in the plate-shaped arch, referred to as dynamic twist. Because of the dynamic twist, the lamella that rests against one of the groove walls, depending on the stroke direction, produces a good oil control effect, in combination with the asymmetrical incline of the working surface—the “edge” works—while the other lamella, in each instance, has improved hydrodynamics because of the defined barrel shape of the working surface—the “surface” works—as shown in **FIG. 1**. In this way, the friction power at this lamella, which furthermore has a worse oil control effect in the twisted state, is reduced. A change in the stroke direction causes the two lamellae to flip over into the other position, in each instance, but this fundamentally does not change anything with regard to the relationships described.

[0016] Attention must be paid to ensure orientation of the lamella in the correct position when the multi-part steel-band oil control ring is put together; this can be guaranteed, for example, by means of color markings on one of the lamella walls.

[0017] The production of the working surface shape, i.e. contour can take place by means of lapping, for example.

REFERENCE SYMBOLS

- [0018] **10** oil control ring
- [0019] **1** lamella
- [0020] **2** lamella
- [0021] **3** vertex line (edge)
- [0022] **3'** vertex line (edge)
- [0023] **4** spreading spring
- [0024] **5** ring groove wall on the piston crown side
- [0025] **6** ring groove wall on the side facing away from the piston crown
- [0026] **7** ring groove
- [0027] **8** cylinder wall
- [0028] **9** piston
- [0029] h , h' working surfaces

1. Multi-part oil control ring (**10**) for pistons of internal combustion engines, having two lamellae (**1**, **2**) consisting of steel strips and having parallel walls, the working surfaces (h , h') of which have a barrel-shaped asymmetrical shape, in each instance, having a vertex line (**3**, **3'**) that extends over the circumference of the lamellae, as well as a spreading spring (**4**) disposed between the lamellae, which presses the lamellae both axially against one of the walls (**5**, **6**) of a ring groove (**7**) in the piston, in each instance, and radially against the cylinder wall (**8**),

wherein

the working surfaces (h , h') of the two lamellae (**1**, **2**) are configured in such a manner that they correspond to a final contour approaching a condition of wear in the run-in state of the engine, whereby the vertex lines (**3**, **3'**) of the working surfaces (h , h') are oriented in the opposite direction to the center of the ring groove (**3**), in each instance, in the assembled state of the oil ring (**10**) in the piston.

2. Multi-part oil control ring according to claim 1, wherein the working surfaces (h , h') of the two lamellae (**1**, **2**), in cross-section,

follows the asymmetrical shape of a polynomial of the second order in a first segment (I), with $h(x)=ax+bx^2$, whereby

x =working surface coordinates in the Cartesian coordinate system in mm, and a , b are coefficients, with a being defined by the ratio of the axial wall play of the lamellae relative to the width of the lamellae; b being defined as the amount of the working surface curvature;

a supporting vertex (II) $h(x=0)$ configured as an edge, and in a third segment (III) follows the asymmetrical shape of the function $h(x)=cx^2$, with c as a multiple of b .

3. Multi-part oil control ring according to claim 2, wherein the vertex lines (**3**, **3'**) of the working surfaces (h , h') of the lamellae are oriented in the same direction as the wall (**6**) of the ring groove (**8**) that faces away from the piston crown, in each instance.

* * * * *