



US 20040200699A1

(19) **United States**

(12) **Patent Application Publication**
Matsumoto et al.

(10) **Pub. No.: US 2004/0200699 A1**

(43) **Pub. Date: Oct. 14, 2004**

(54) **DEPRESSION RESPONSIVE SWITCH UNIT**

(52) **U.S. Cl. 200/1 B**

(76) Inventors: **Tadanao Matsumoto, Tokyo (JP);**
Naoki Iwao, Tokyo (JP)

(57) **ABSTRACT**

Correspondence Address:
GALLAGHER & LATHROP, A
PROFESSIONAL CORPORATION
601 CALIFORNIA ST
SUITE 1111
SAN FRANCISCO, CA 94108 (US)

A pusher formed of a rubber material, a click plate, a membrane switch which serves as a second step switch, a reinforcing plate, a membrane sheet on which a plurality of first step switches are formed, a key operation base and a knob are sequentially assembled into a case. The knob includes a plurality of depressing pieces having on its internal surface a projection which moves into contact with each membrane switch and also includes a marginal portion which is supported by the top surface of the case. The knob is thin-walled except for the depressing piece, and the thin-walled portion comprises a thermoplastic elastomer or silicone rubber. The knob, the key operation base and the reinforcing plate are secured together. As the depressing piece is depressed, the thin-walled portion which is located therearound becomes flexed, whereby the membrane switch is depressed by the projection to turn the switch on. When the depressing piece is further depressed, the reinforcing plate moves and the click plate reverses, turning the switch on.

(21) Appl. No.: **10/819,568**

(22) Filed: **Apr. 6, 2004**

(30) **Foreign Application Priority Data**

Mar. 29, 2004 (JP) 2004-095640
Apr. 11, 2003 (JP) 2003-108210

Publication Classification

(51) **Int. Cl.⁷ H01H 9/00**

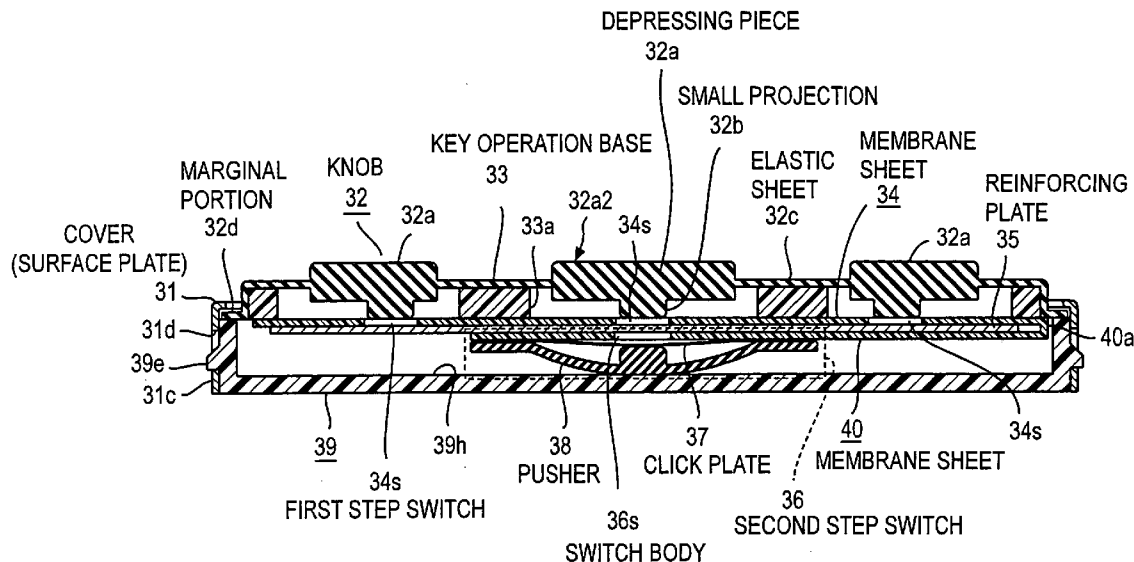

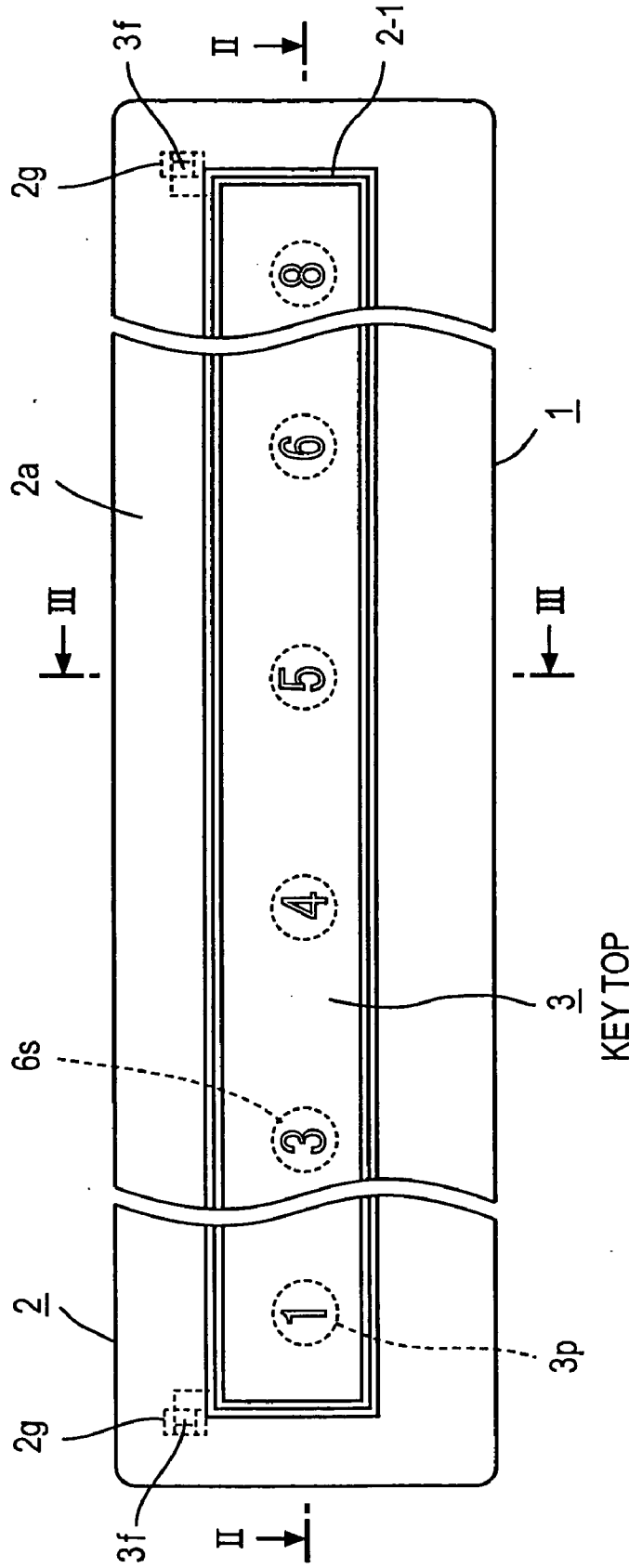

FIG. 1 PRIOR ART

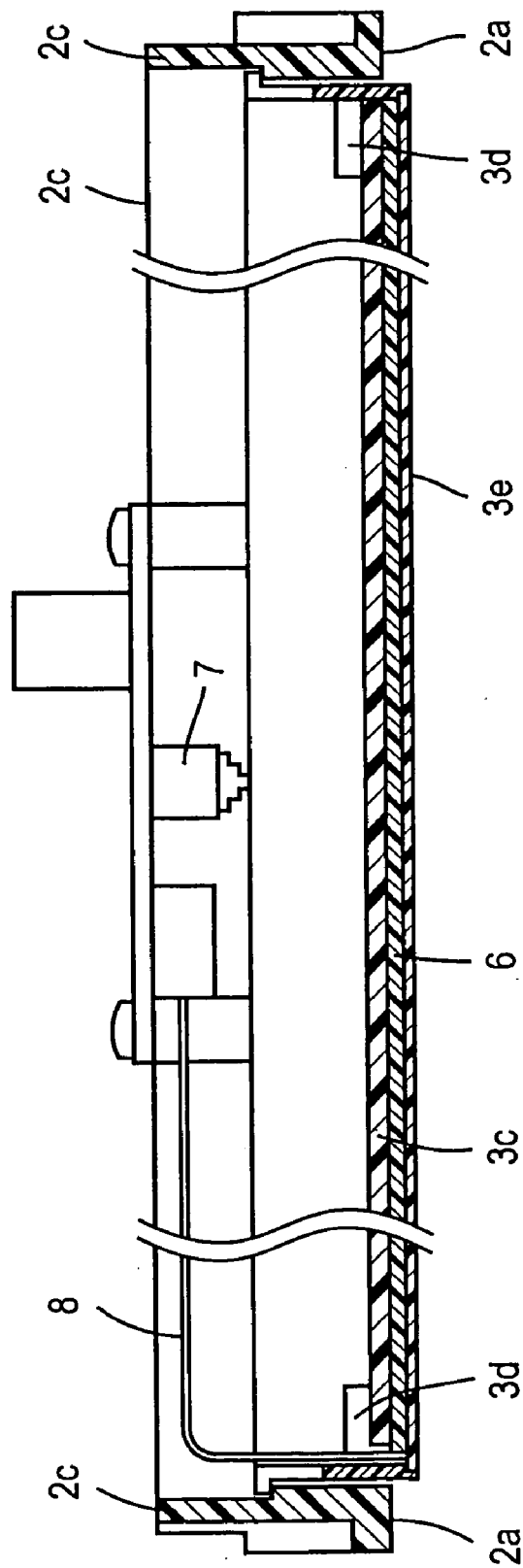

FIG. 2 PRIOR ART

PRIOR ART

FIG. 3B

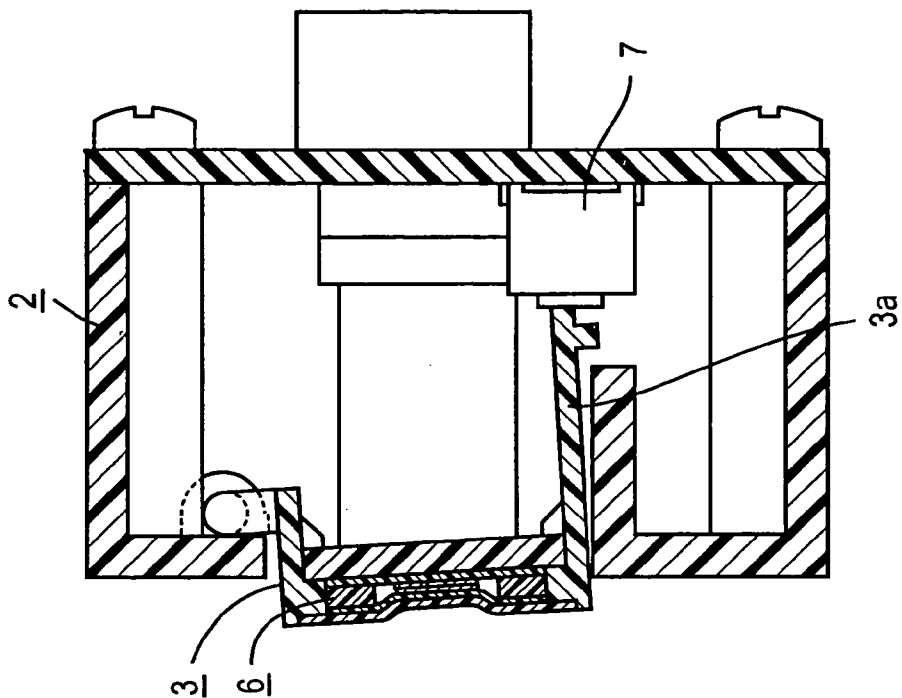
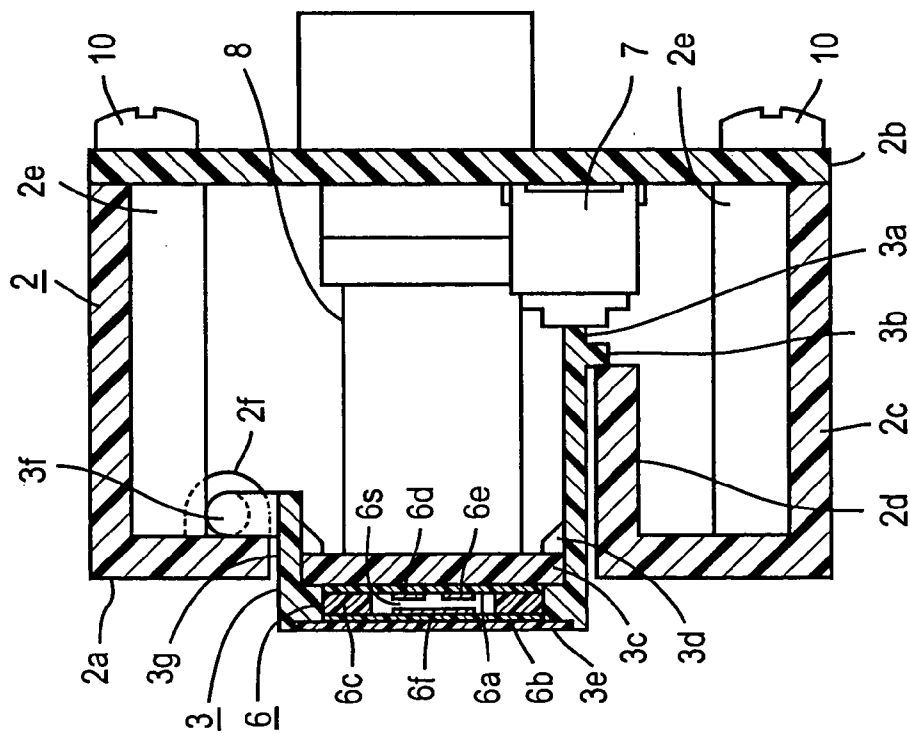

FIG. 3A



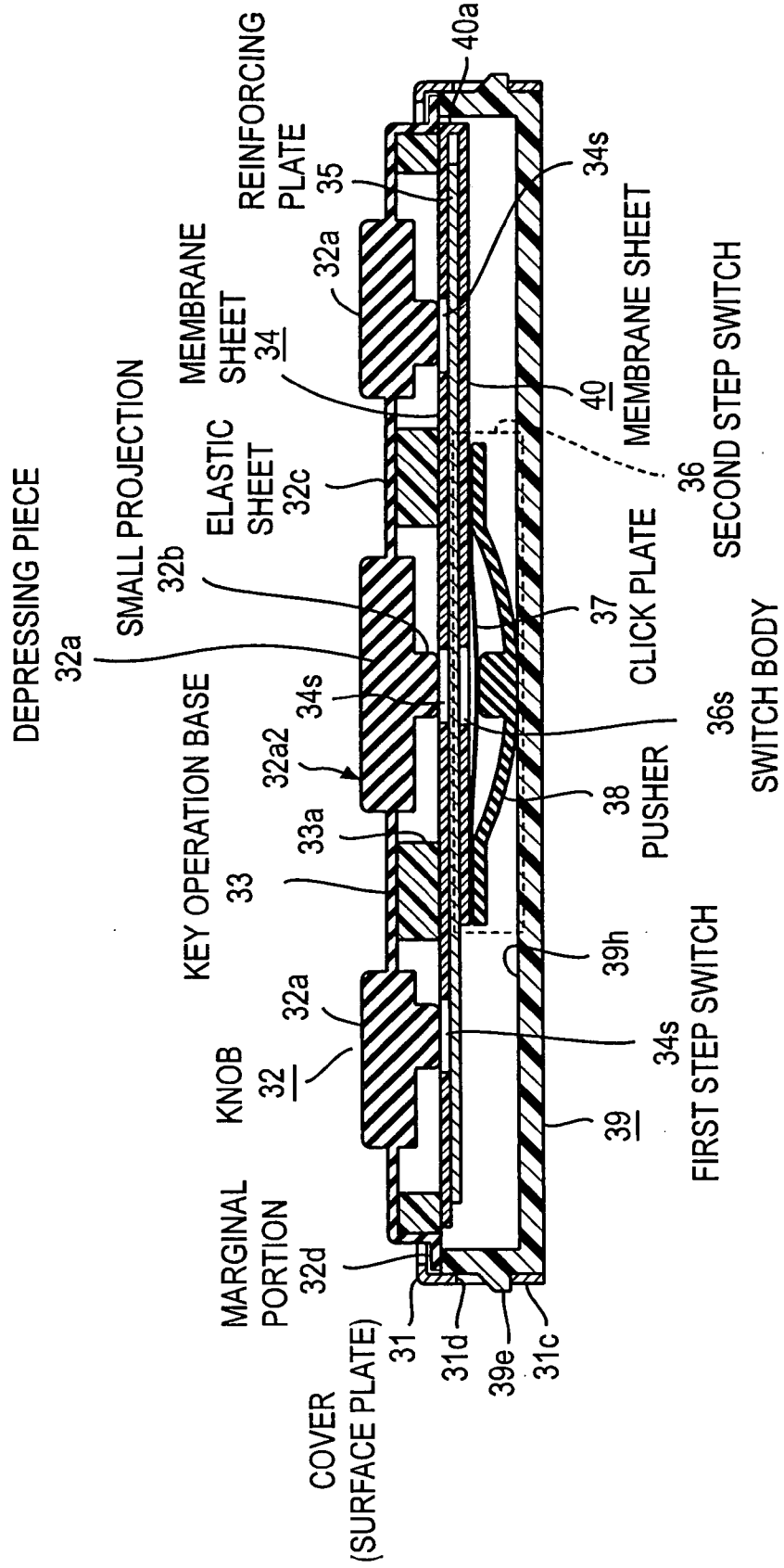

FIG. 4

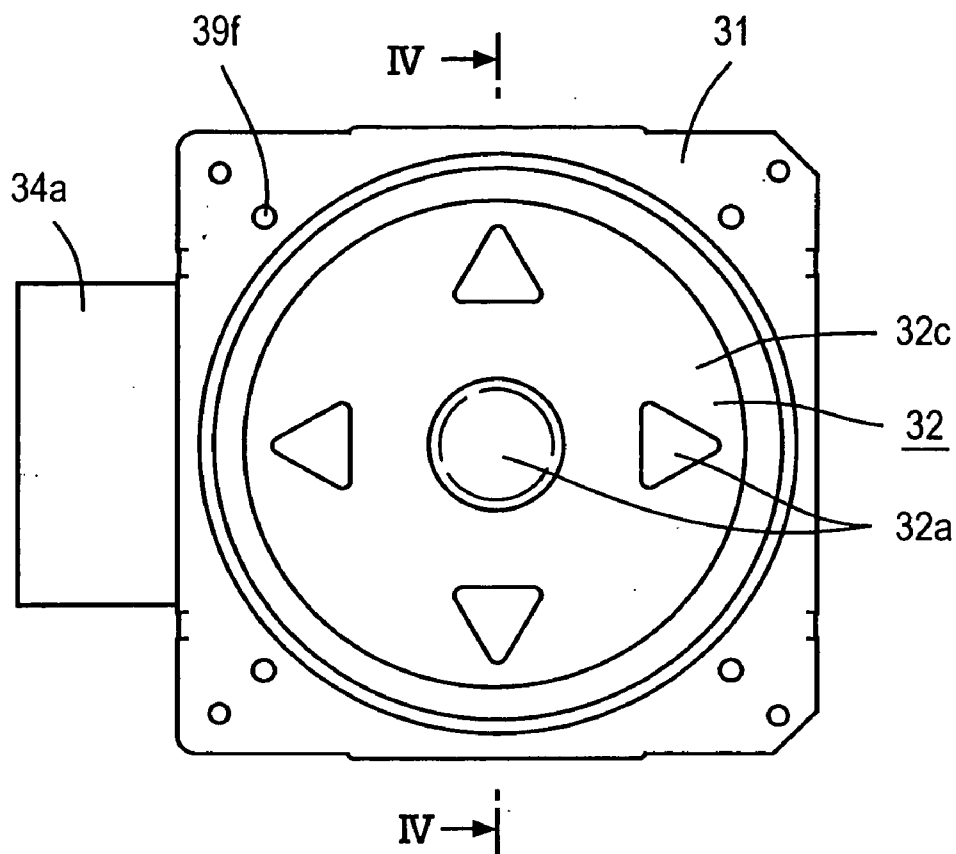

FIG. 5

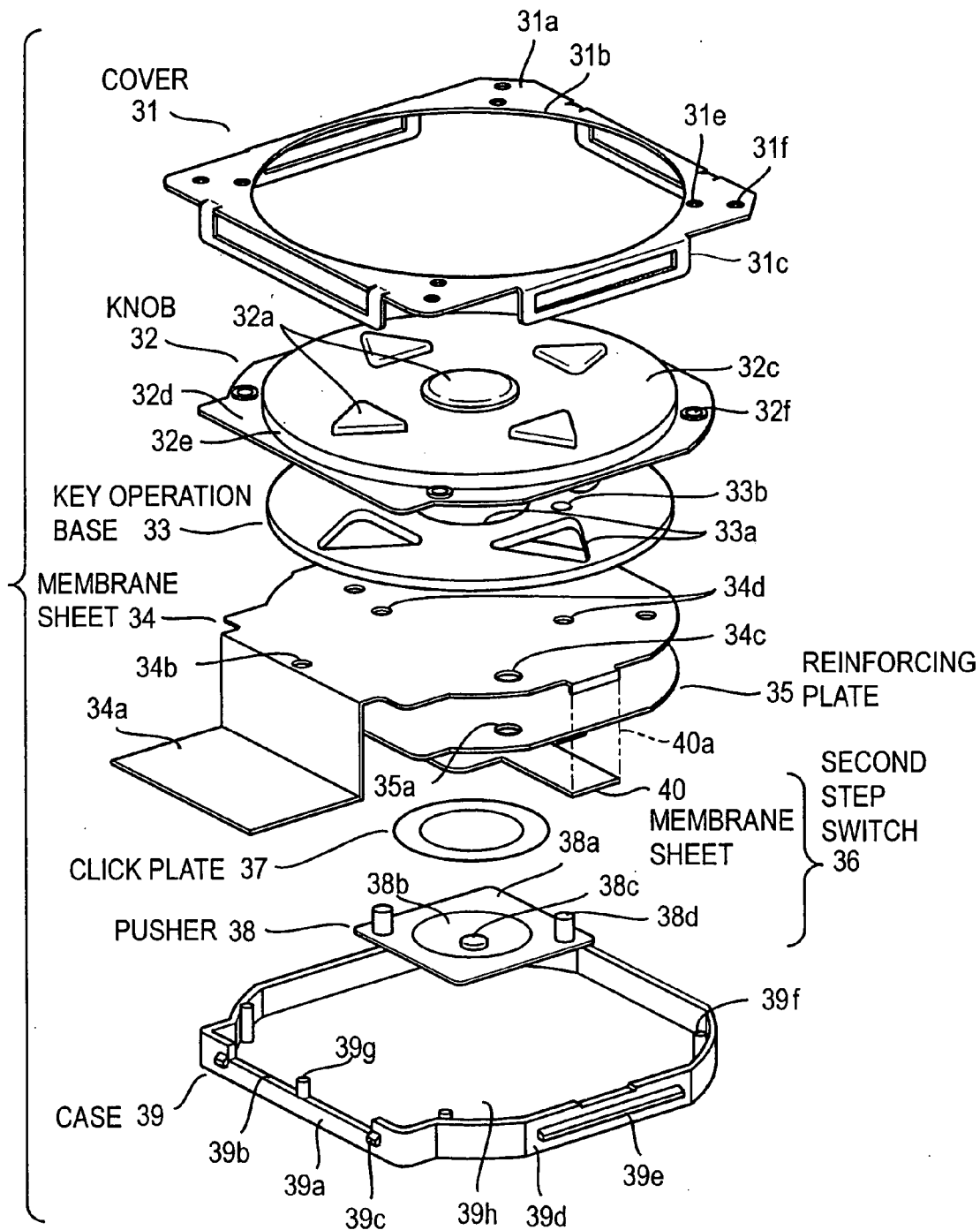
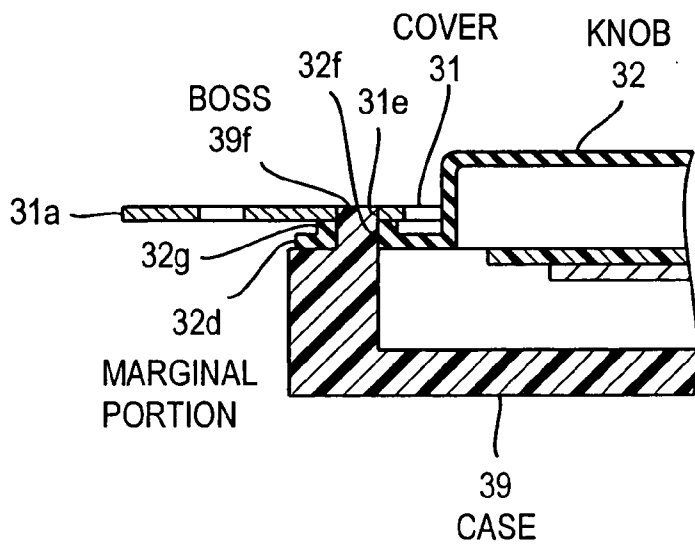
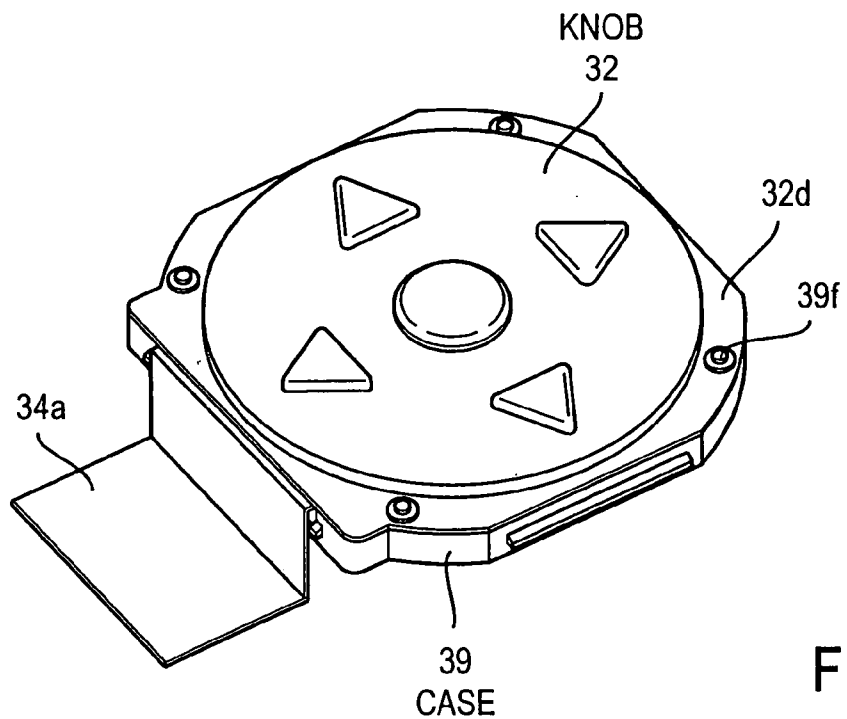
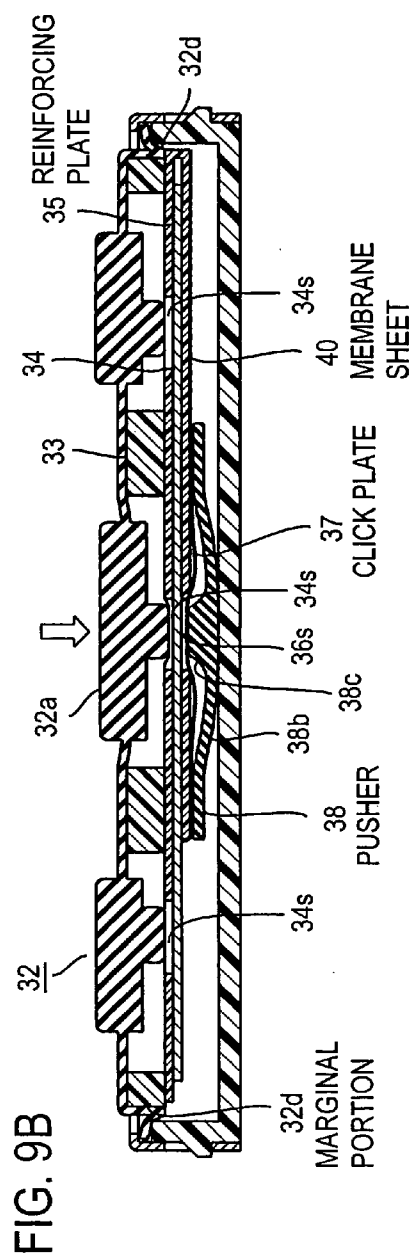
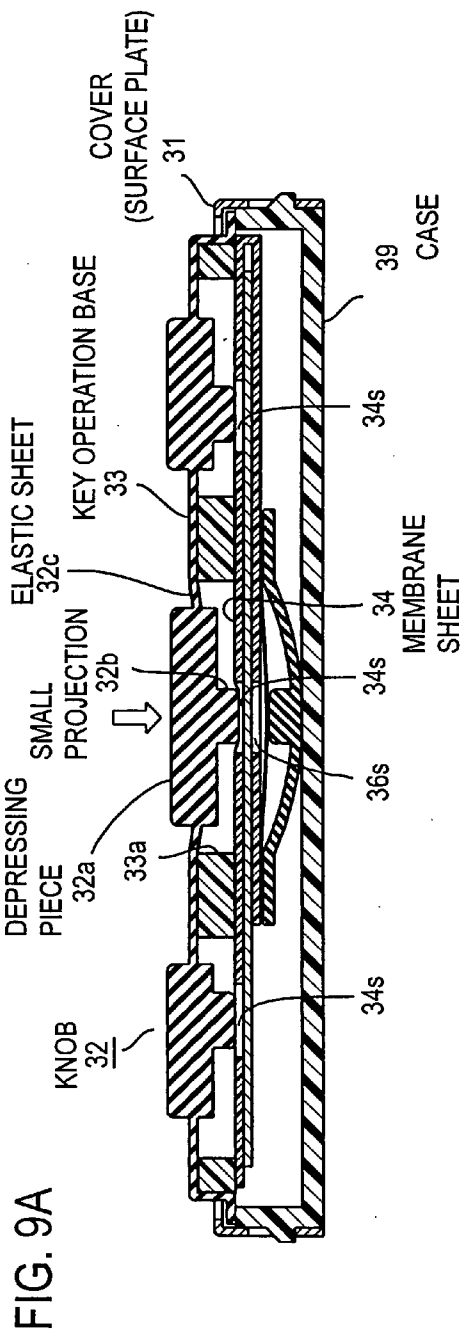

FIG. 6





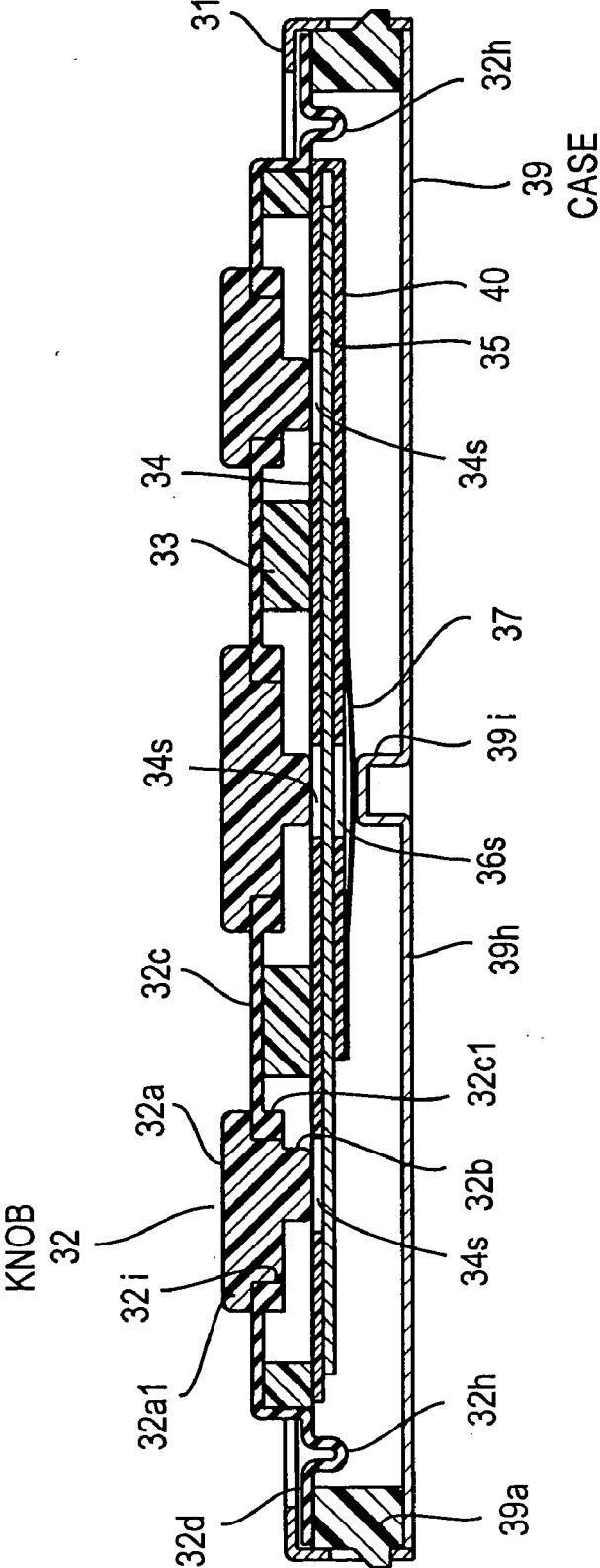

FIG. 10

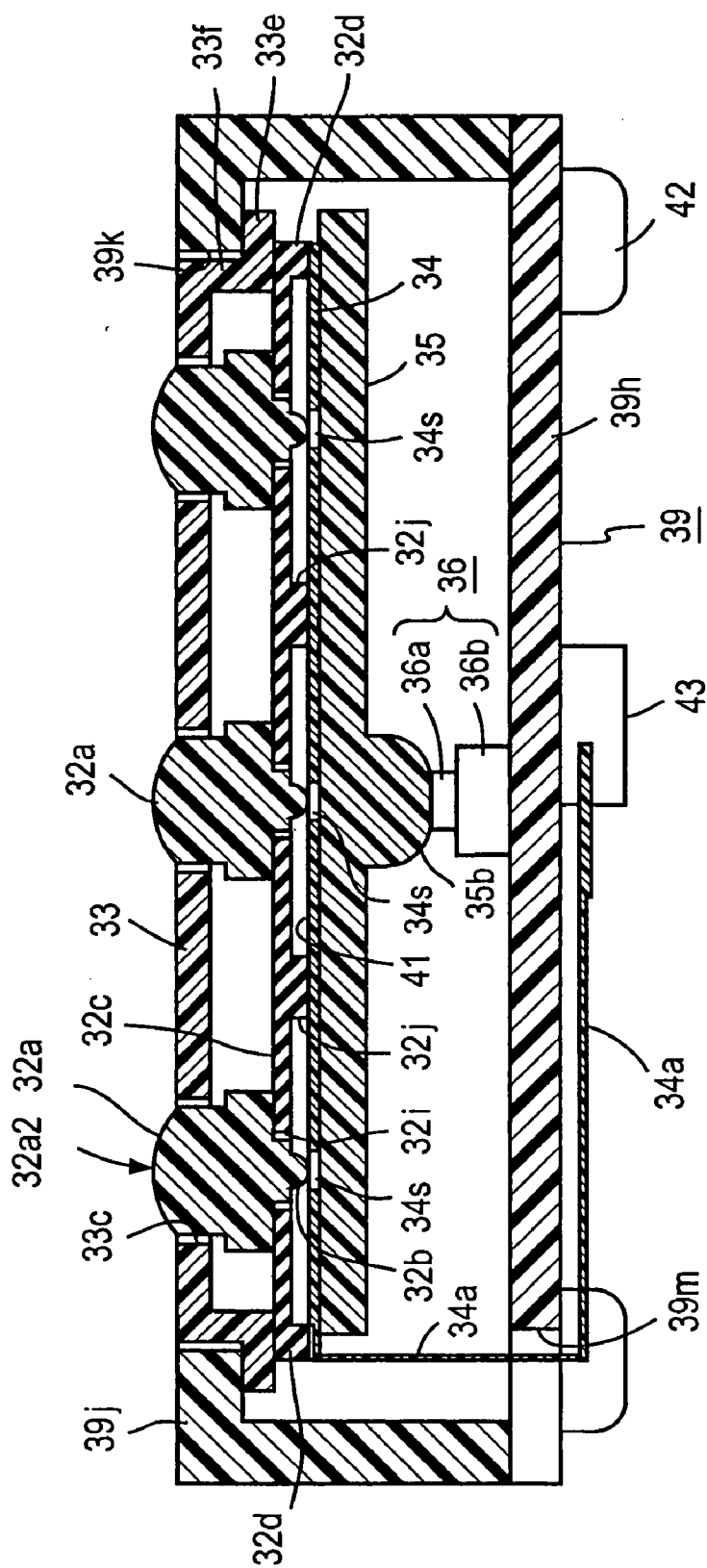

FIG. 11

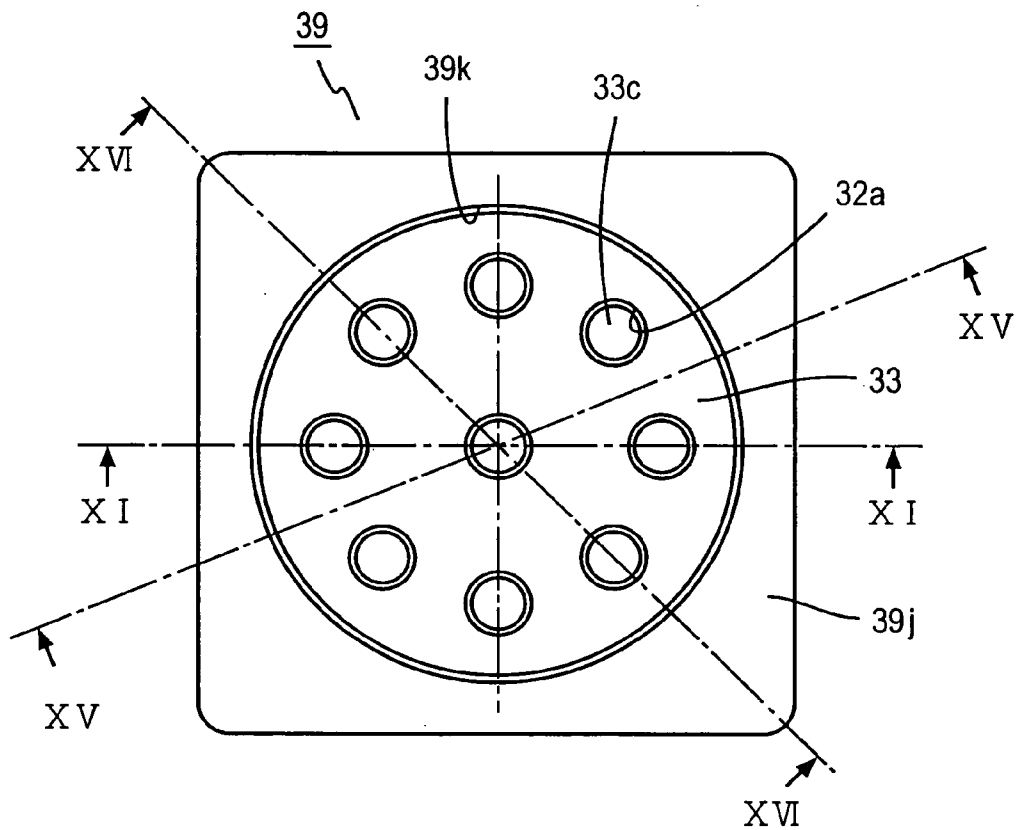

FIG. 12

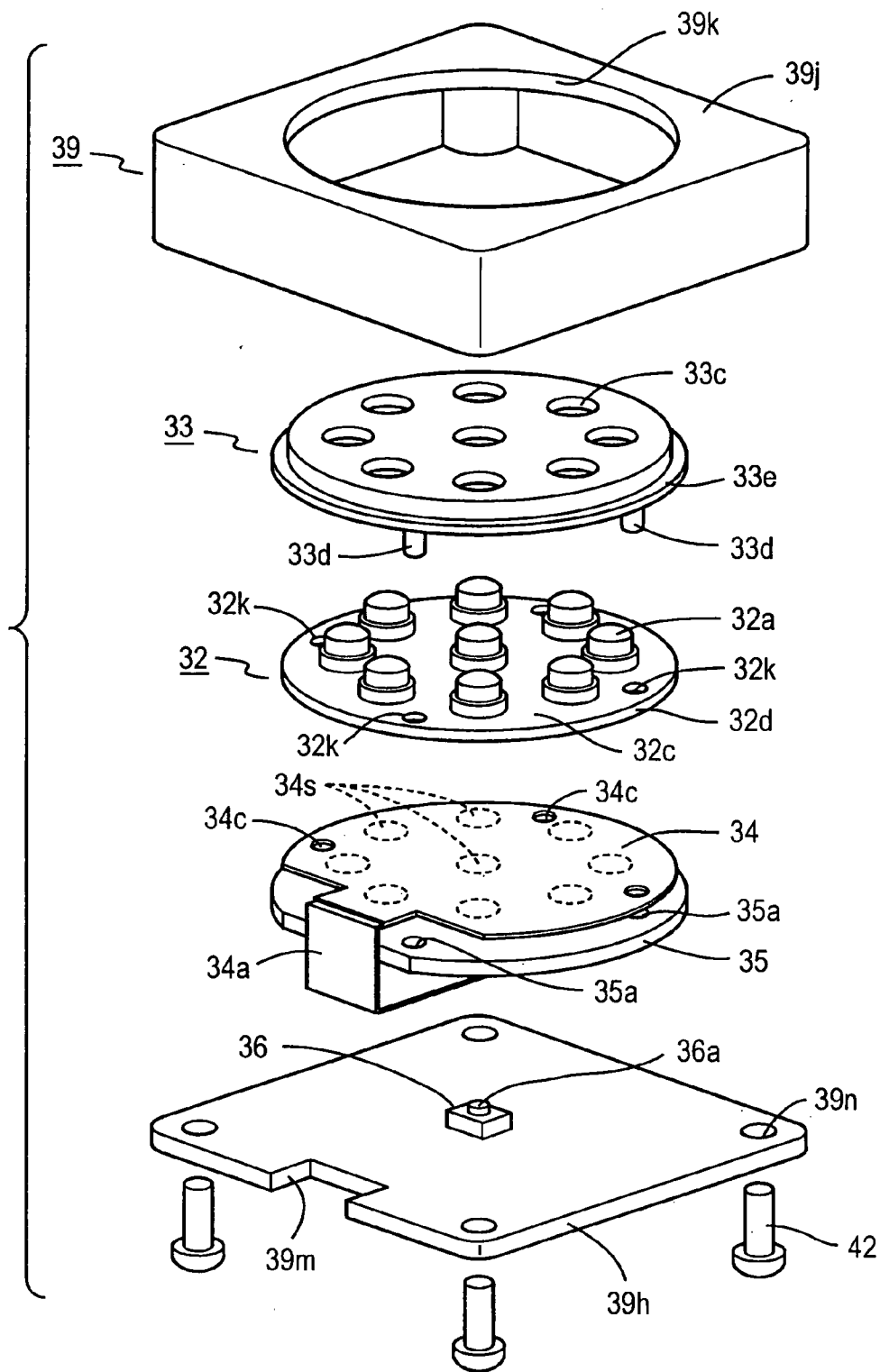

FIG. 13

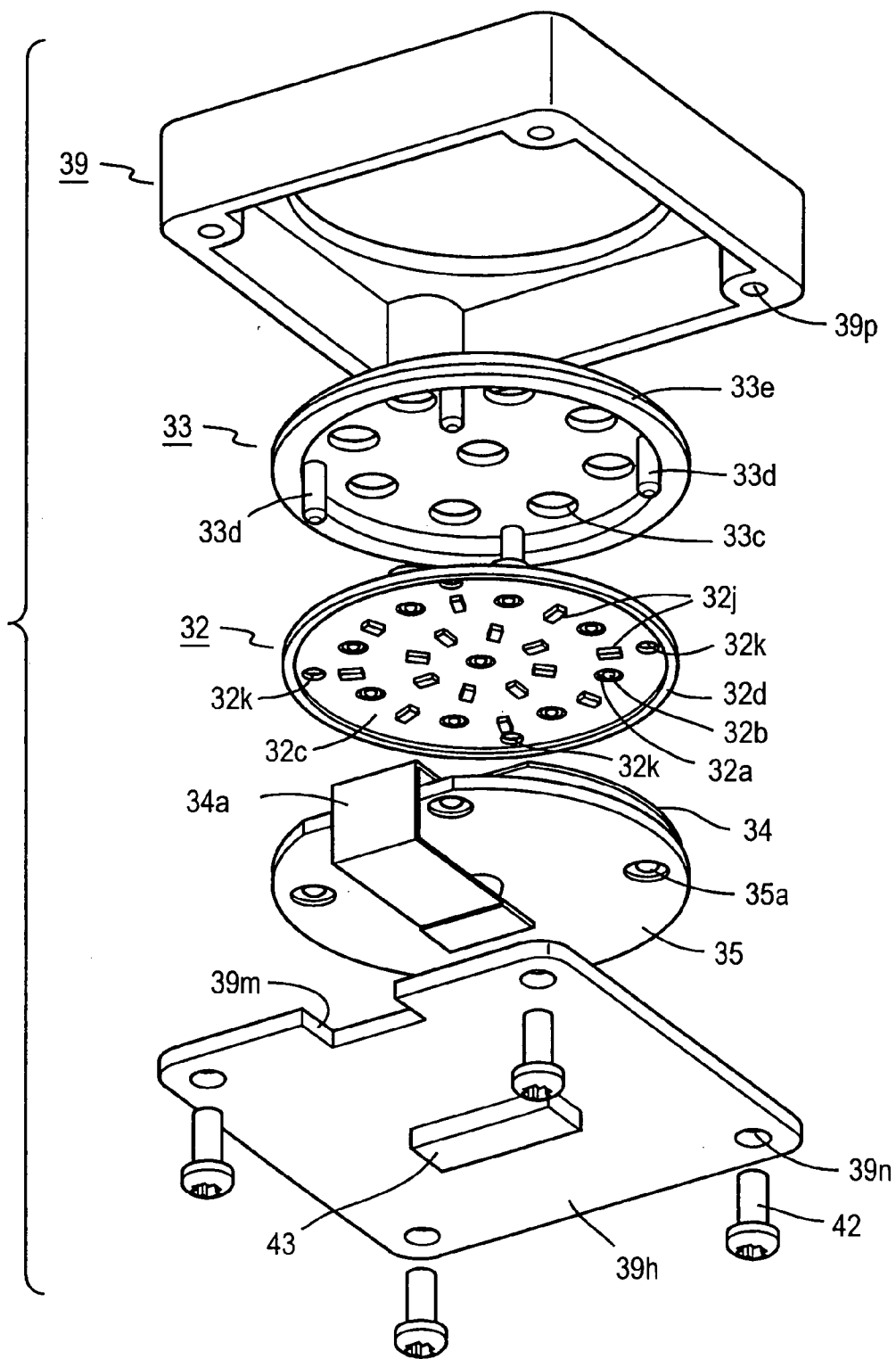

FIG. 14

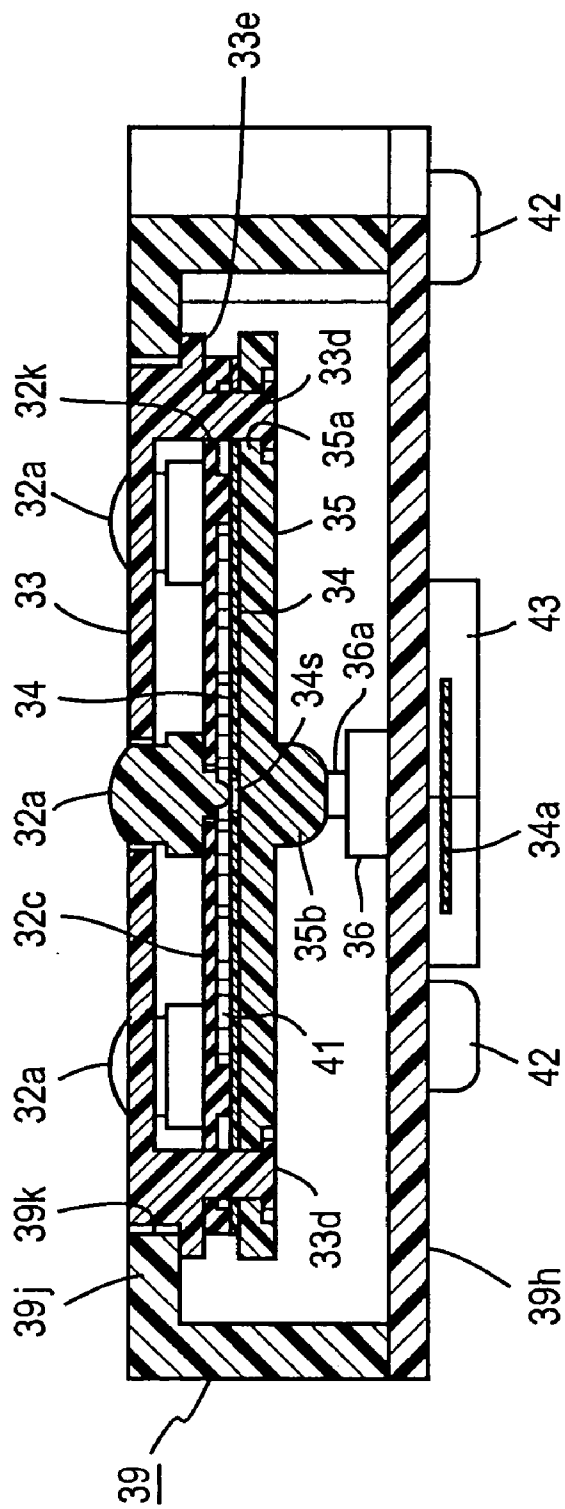

FIG. 15

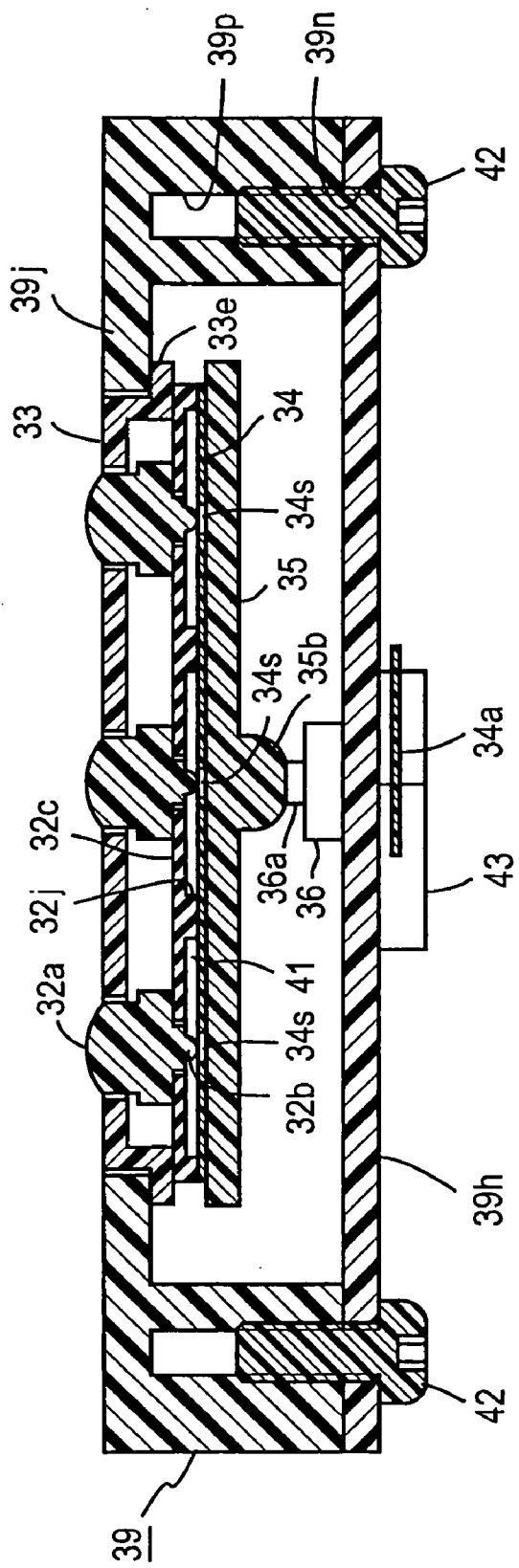

FIG. 16

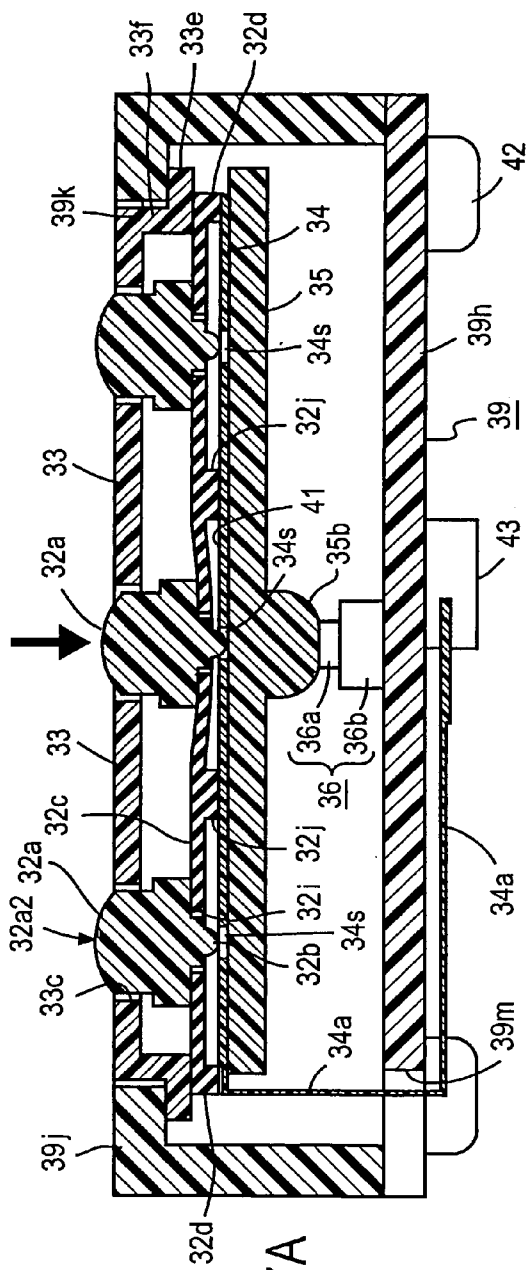

FIG. 17A

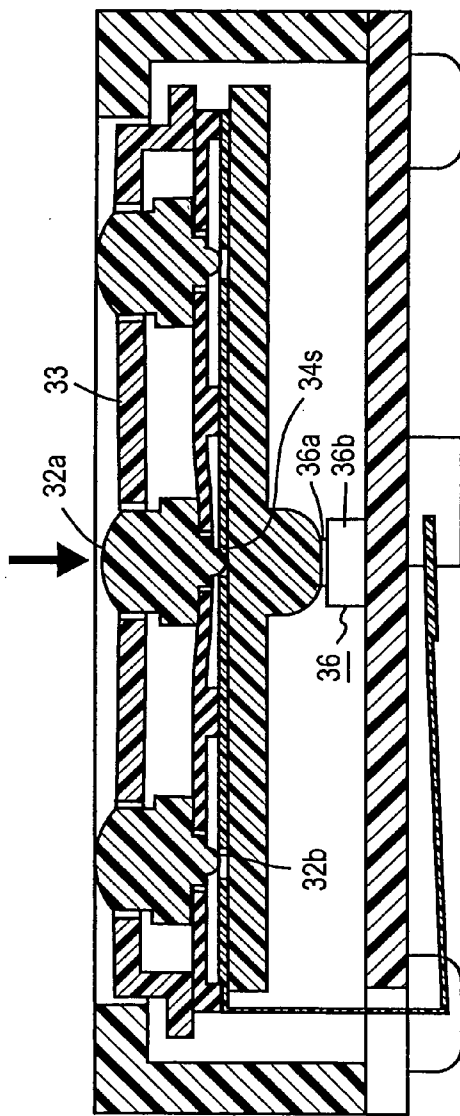

FIG. 17B

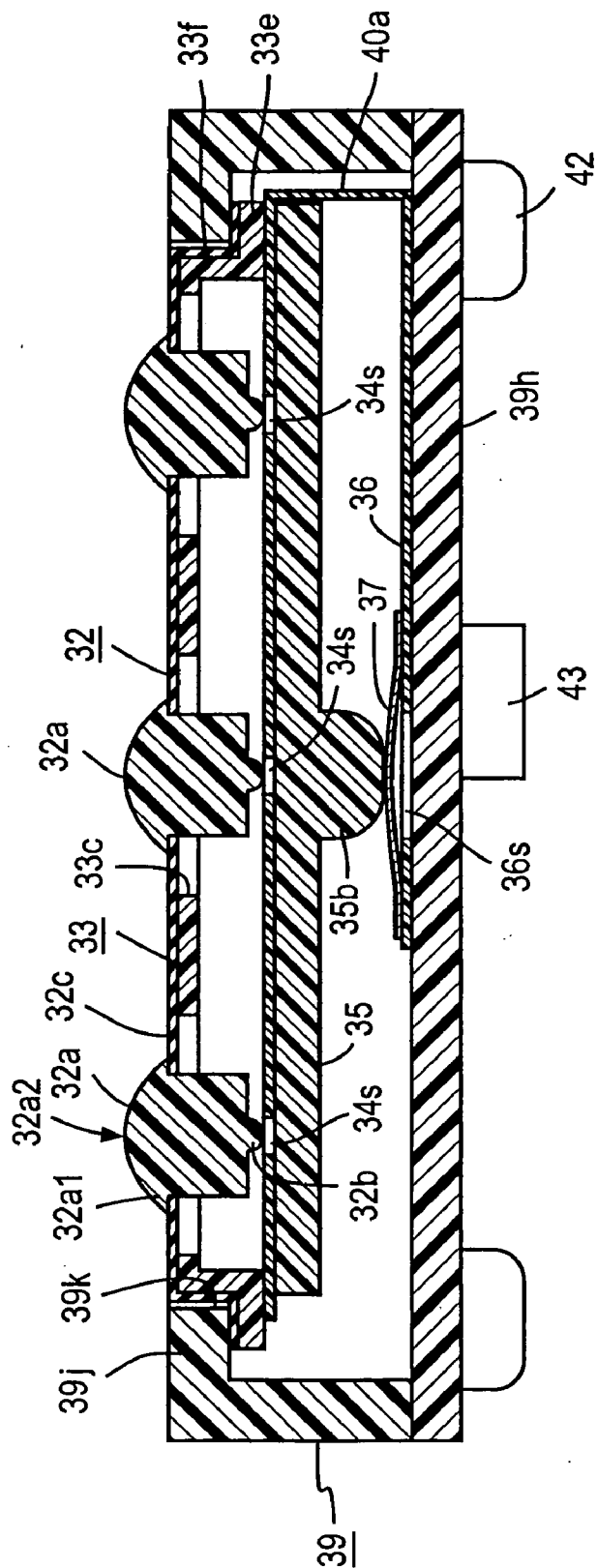

FIG. 18

FIG. 19A



FIG. 19B

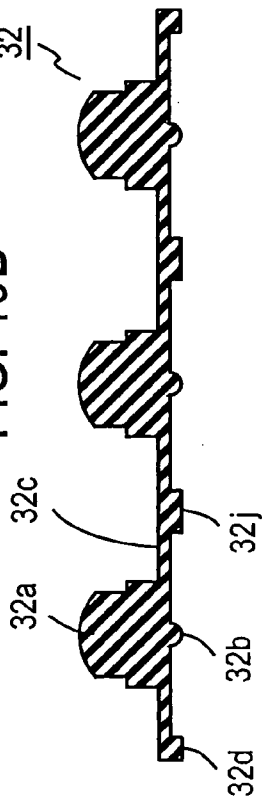

FIG. 19C

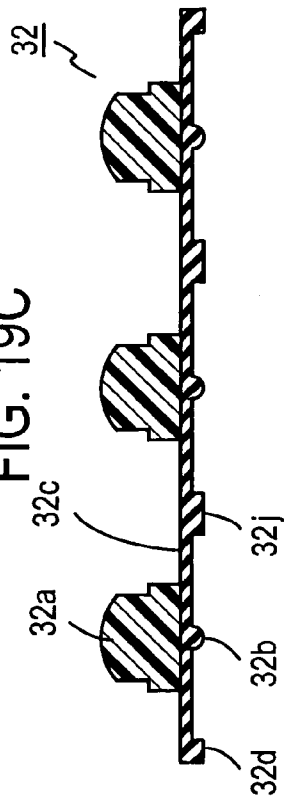

FIG. 19D

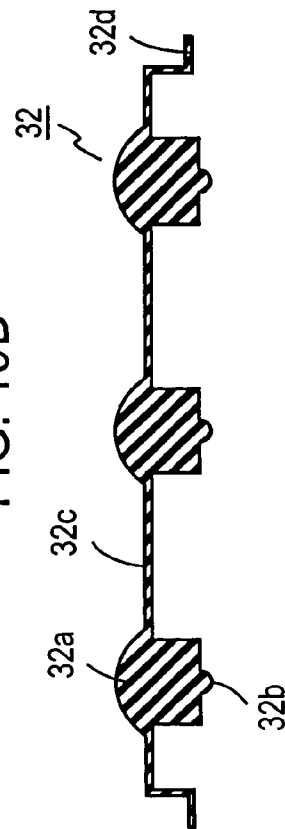

FIG. 19E

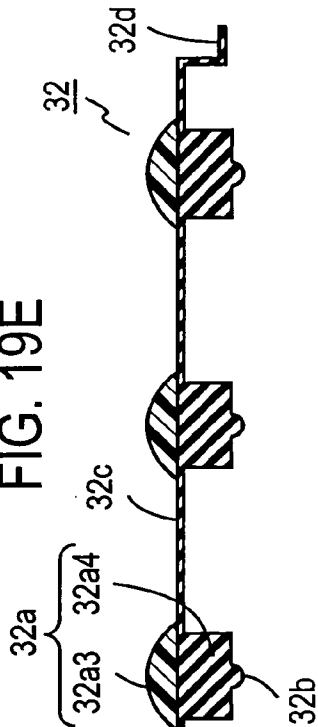

FIG. 20A

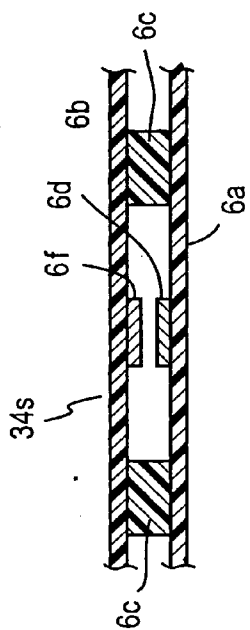

FIG. 20B

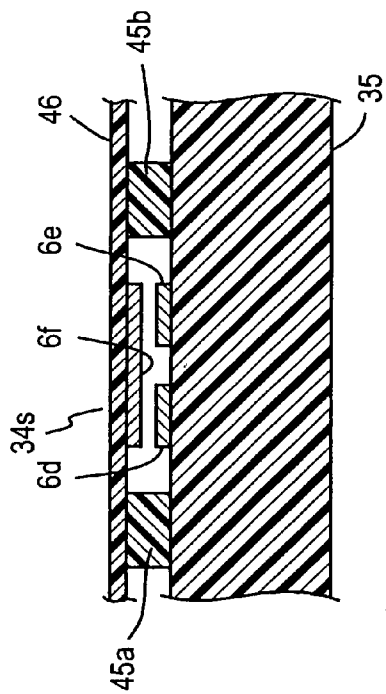

FIG. 20C

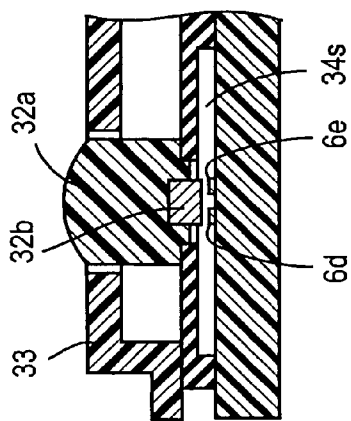

FIG. 20D

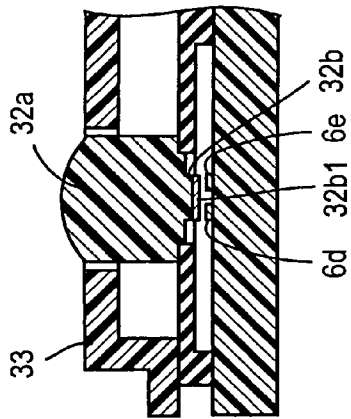

FIG. 21B

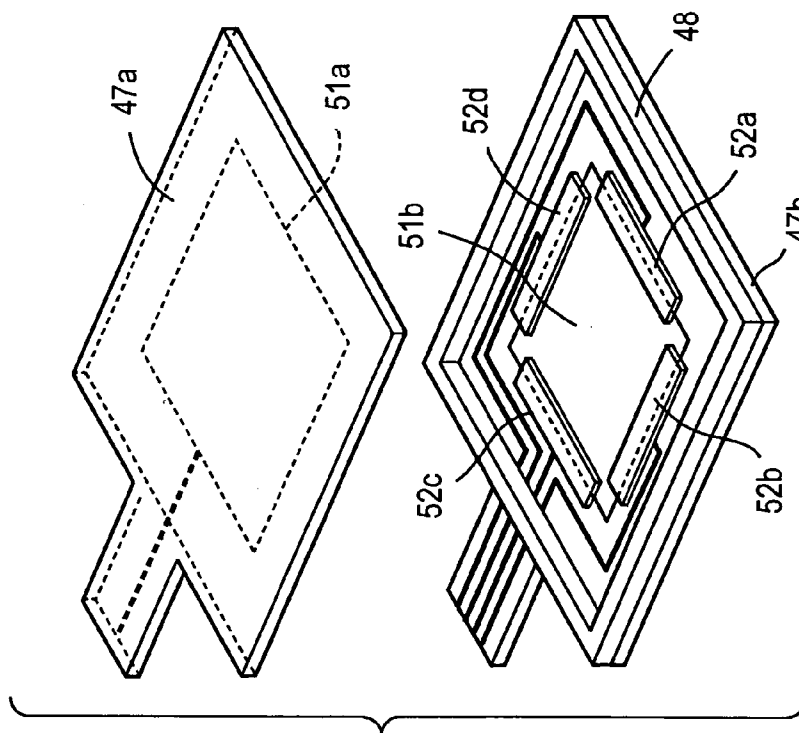

FIG. 21A

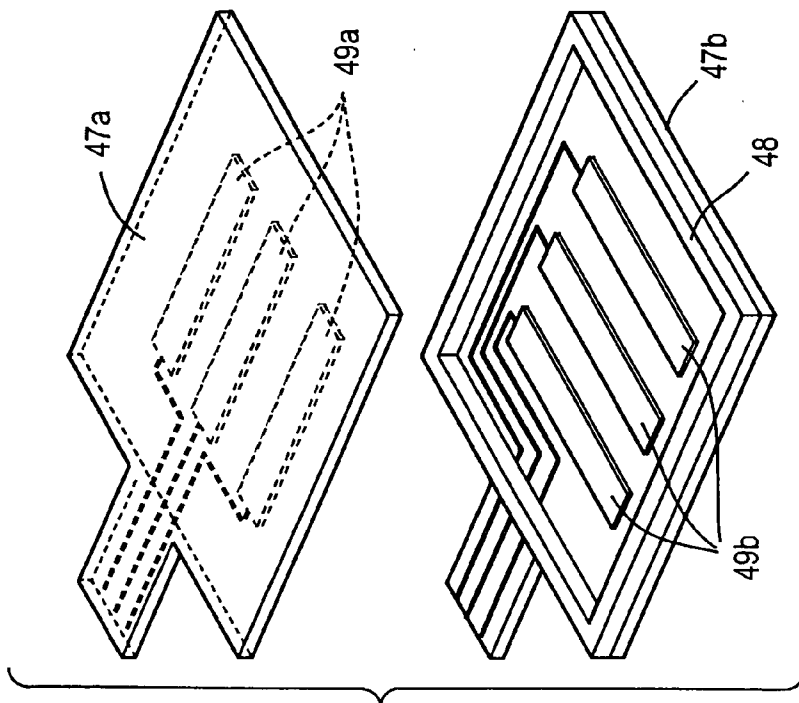

FIG. 22A

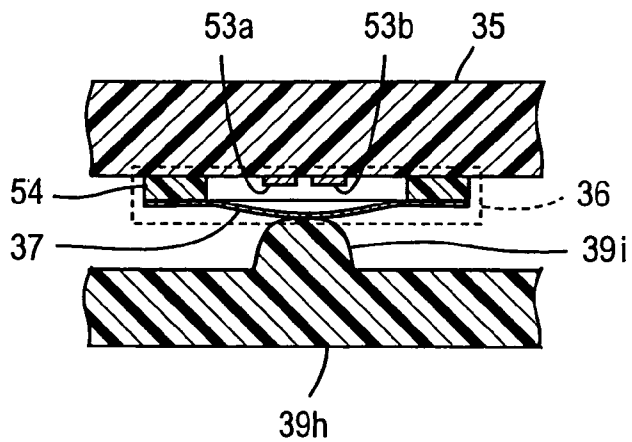
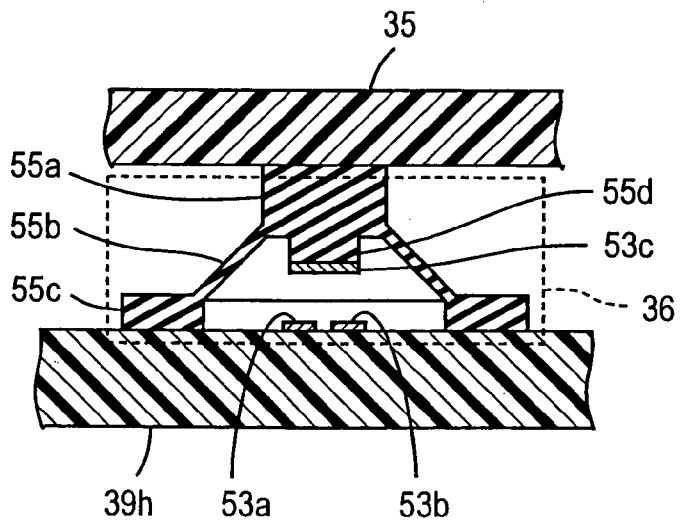

FIG. 22B



PRIOR ART

FIG. 23A

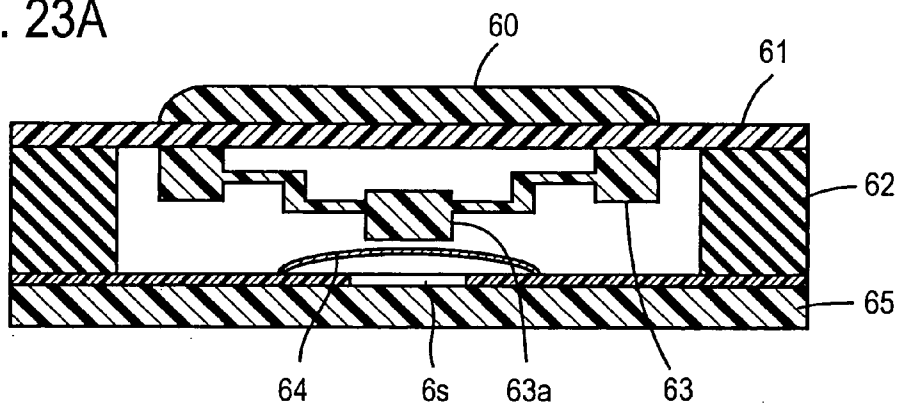

FIG. 23B

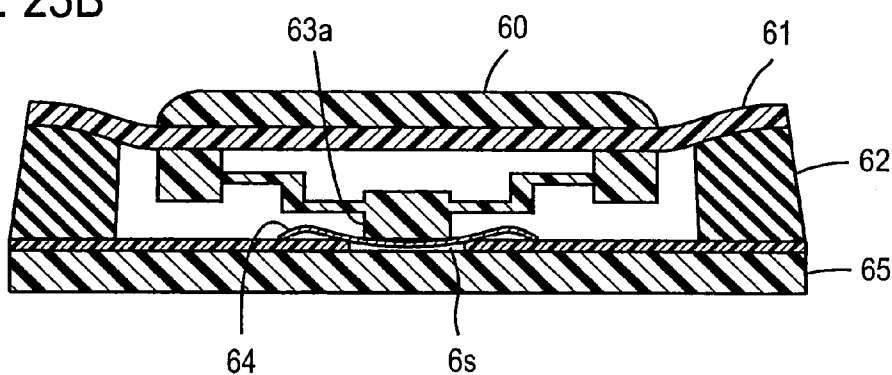
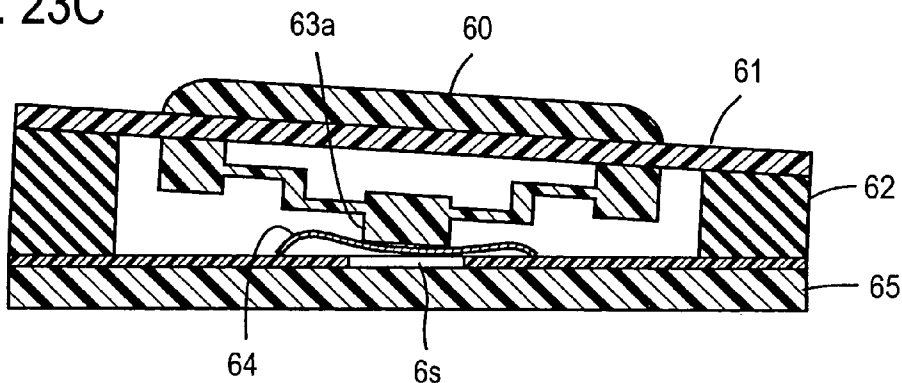

FIG. 23C



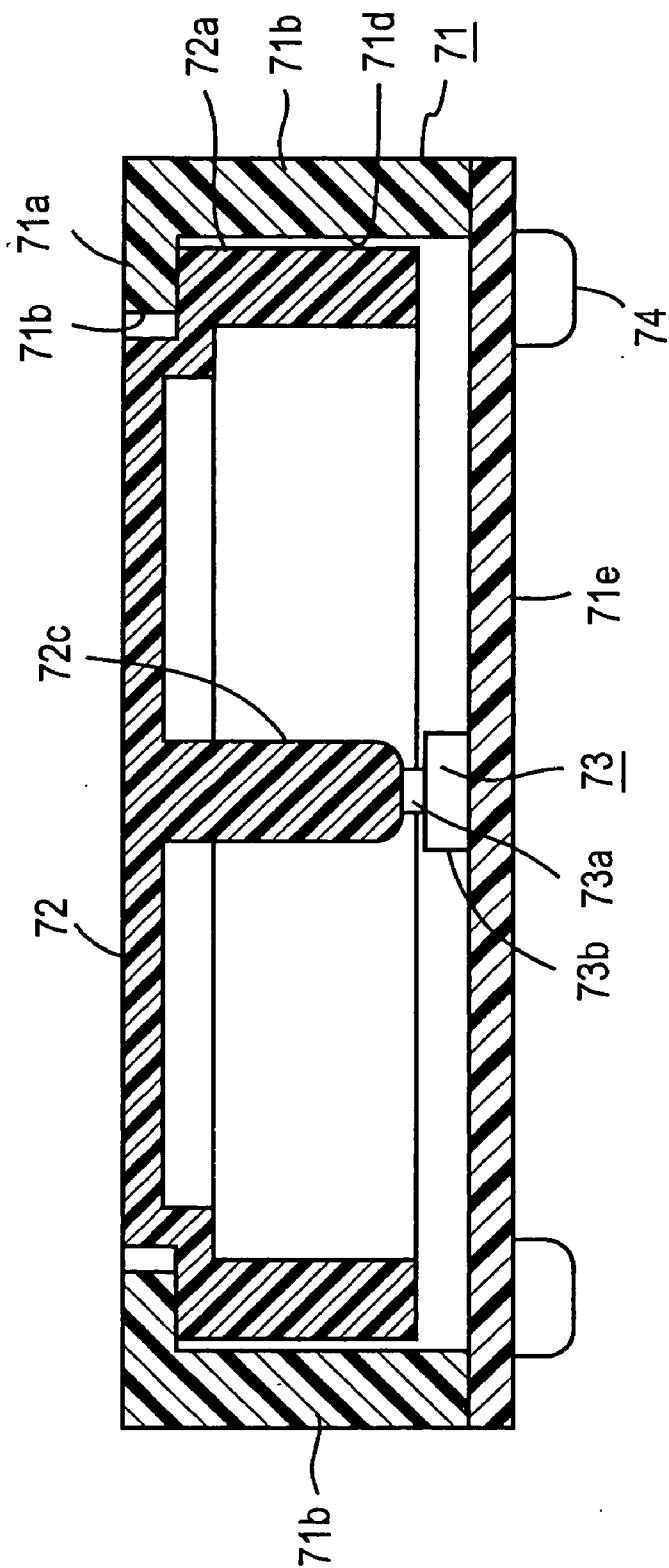
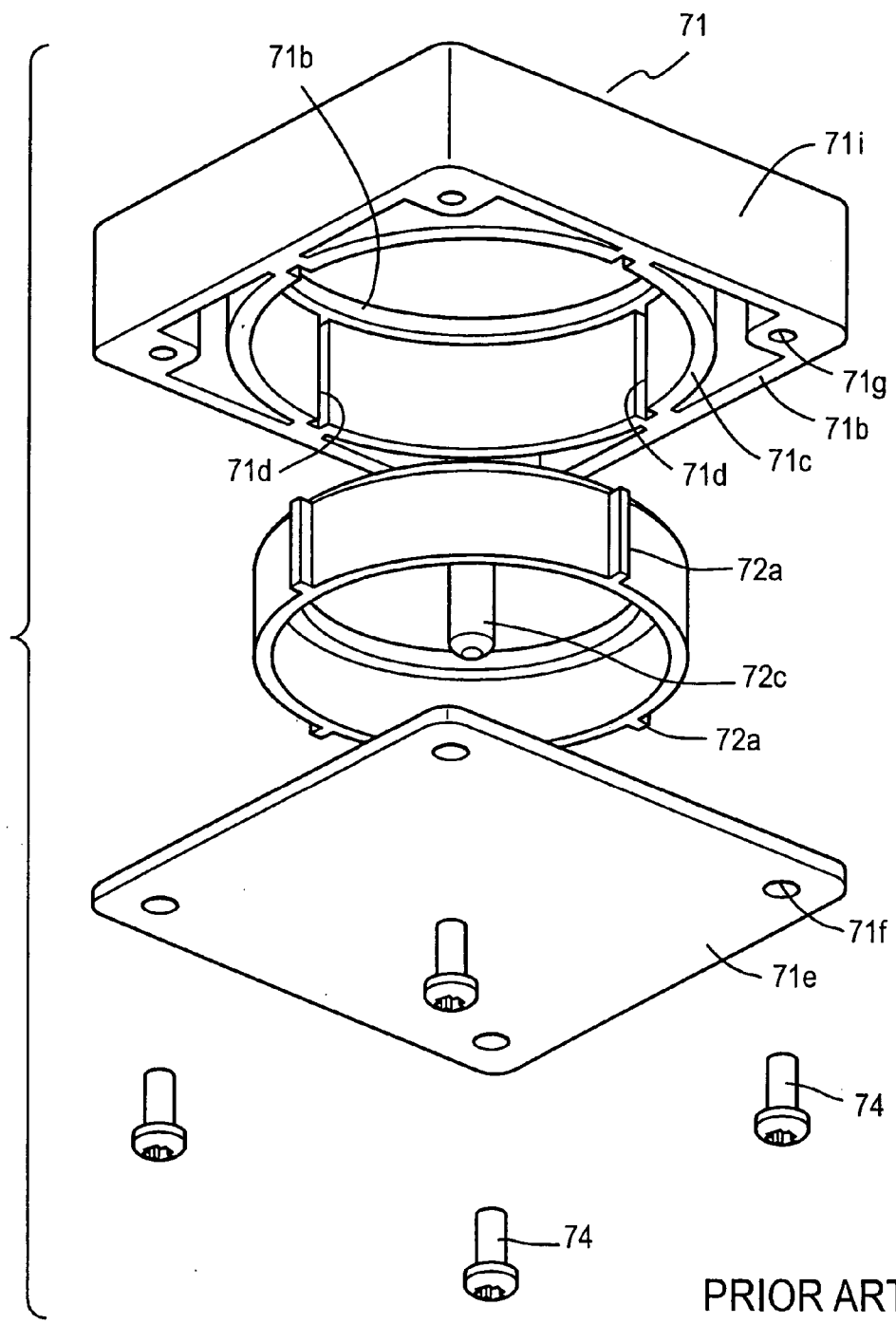

FIG. 24 PRIOR ART



PRIOR ART
FIG. 25

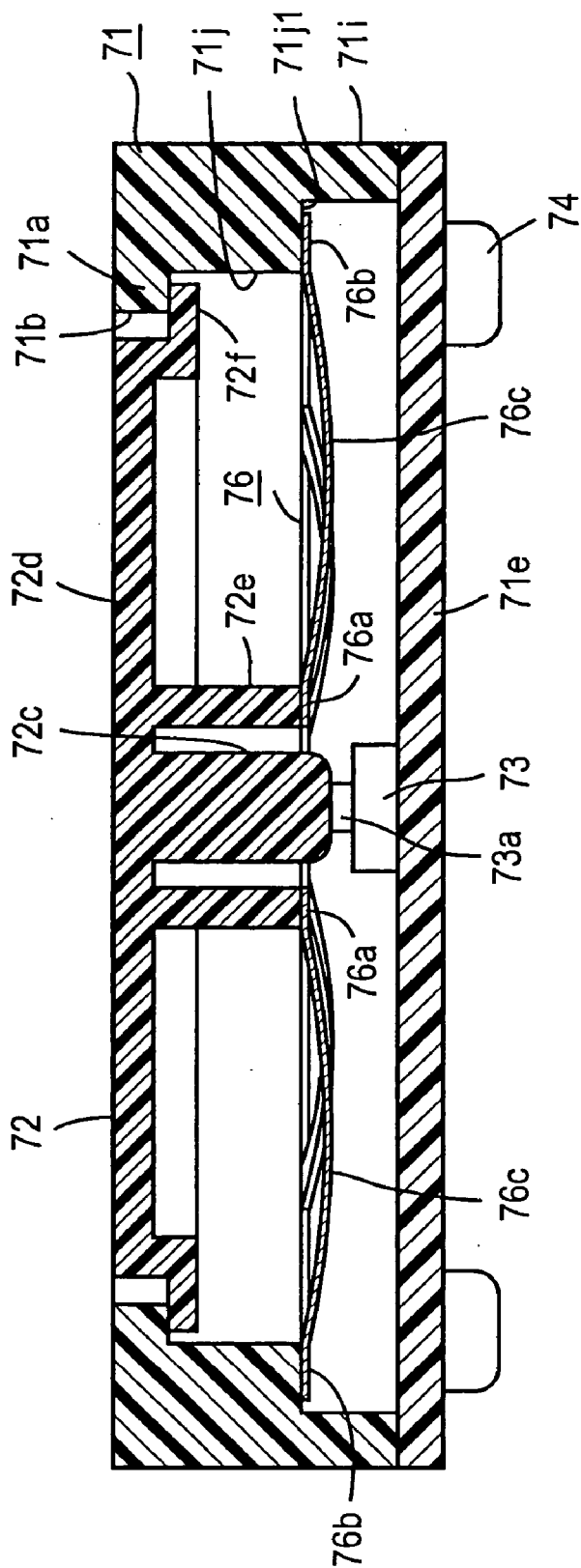

FIG. 26

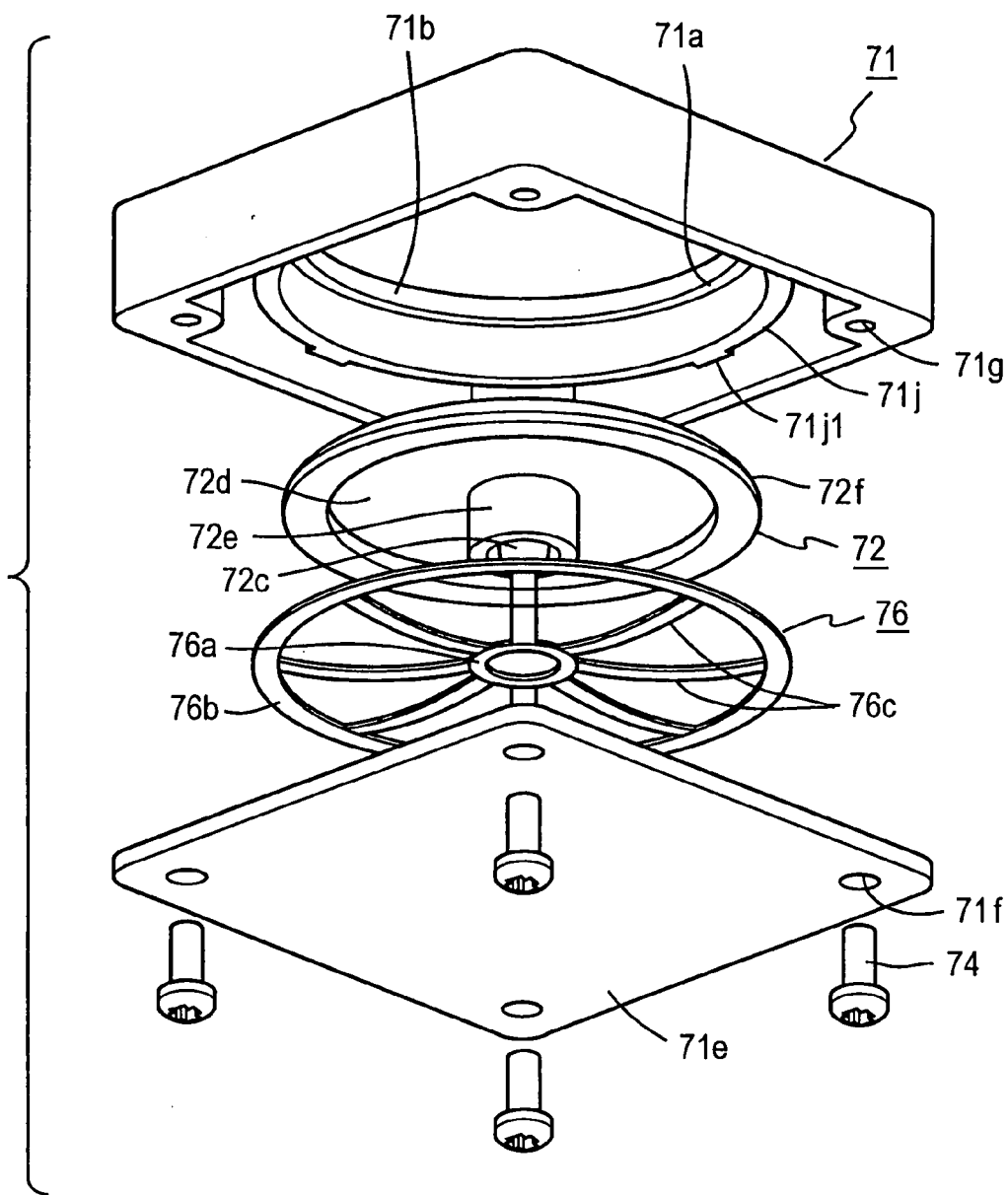

FIG. 27

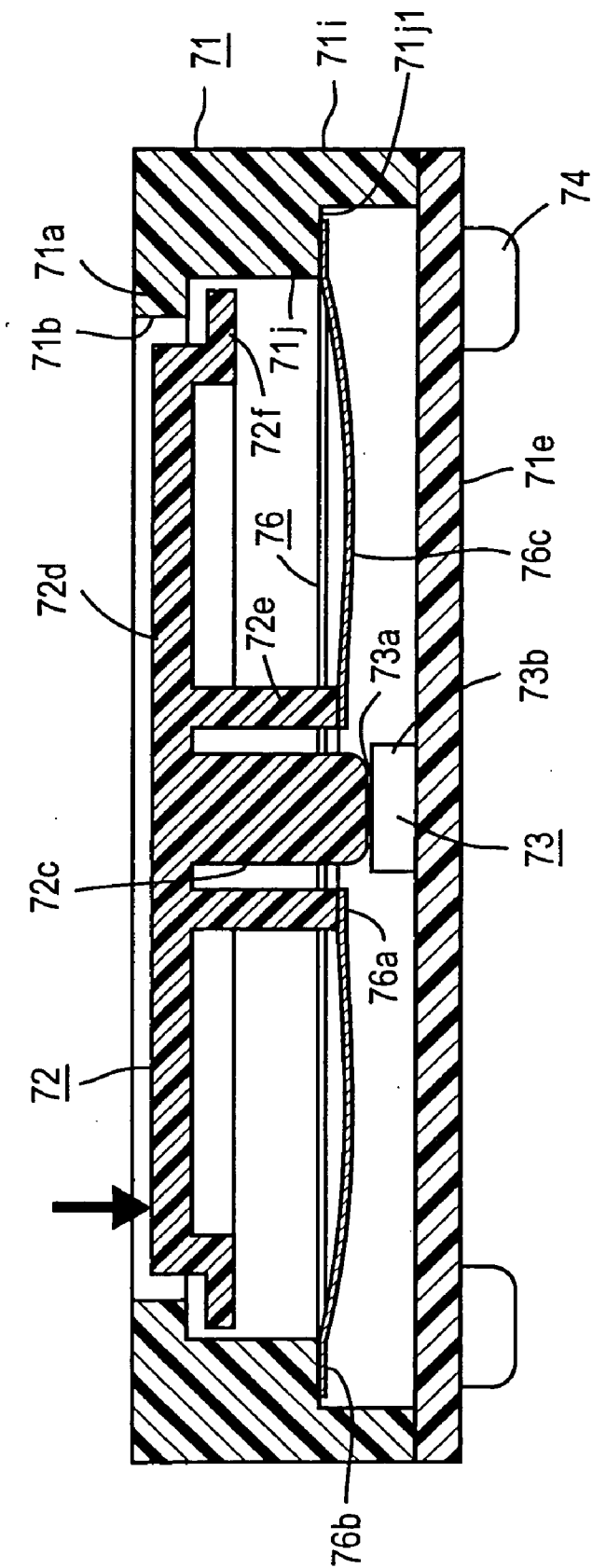

FIG. 28

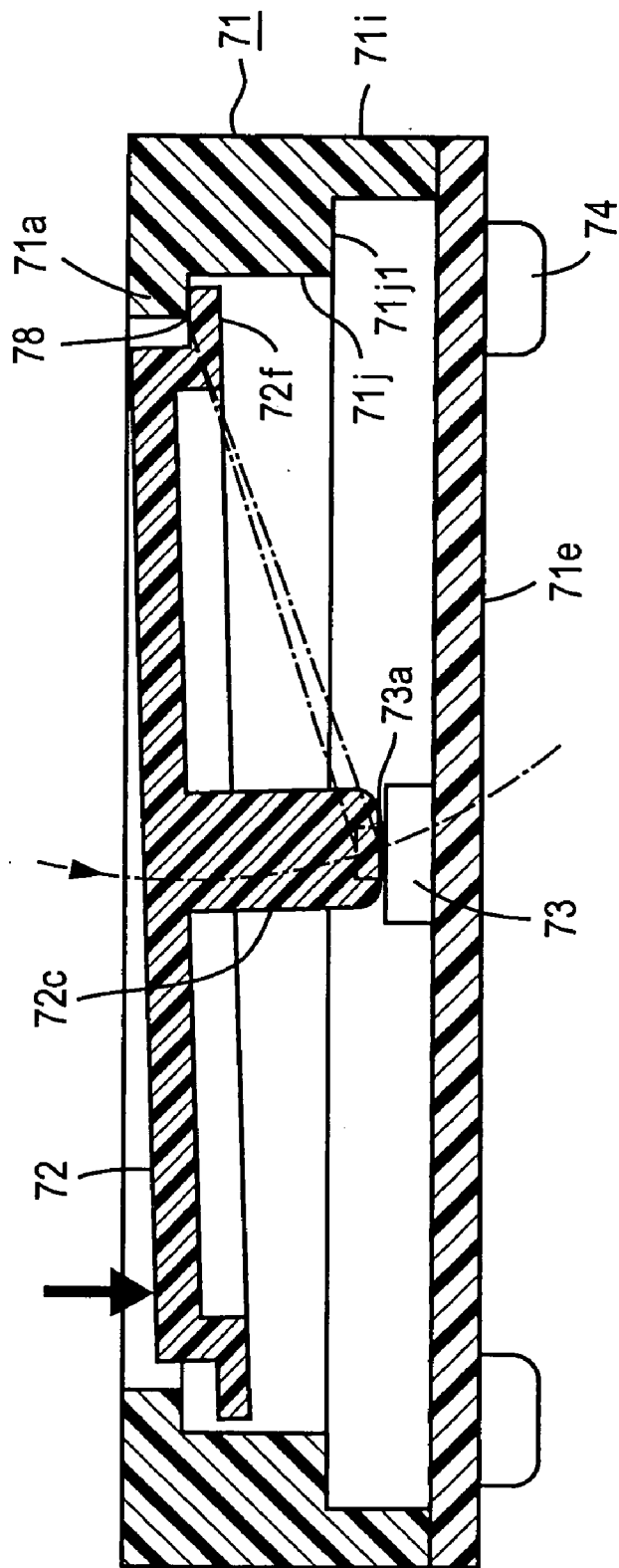

FIG. 29

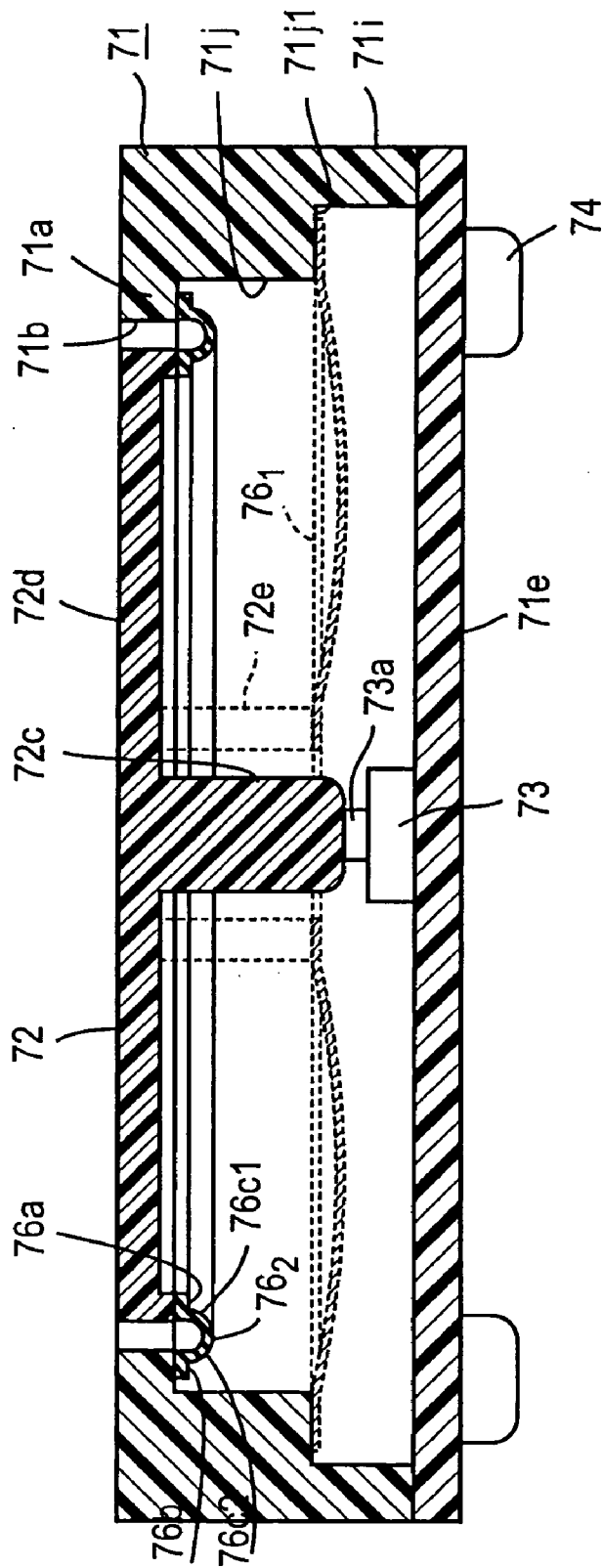

FIG. 30

FIG. 31A

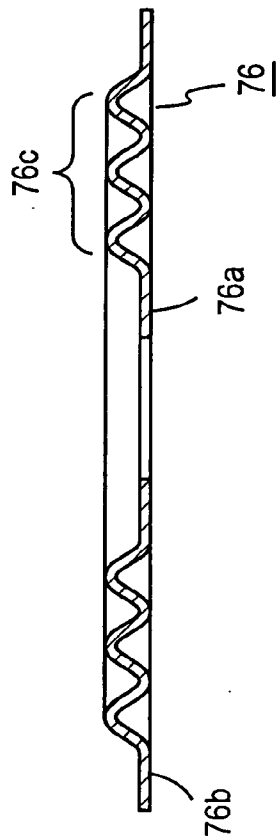

FIG. 31B

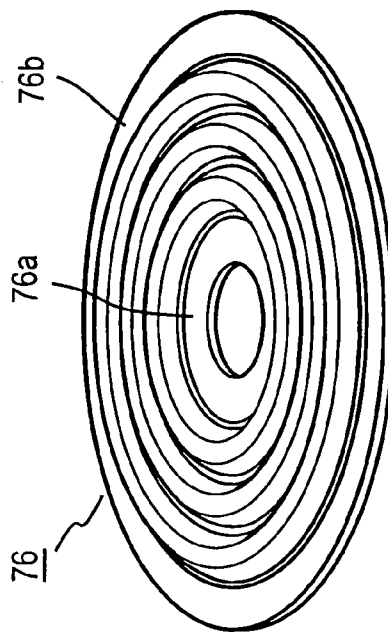
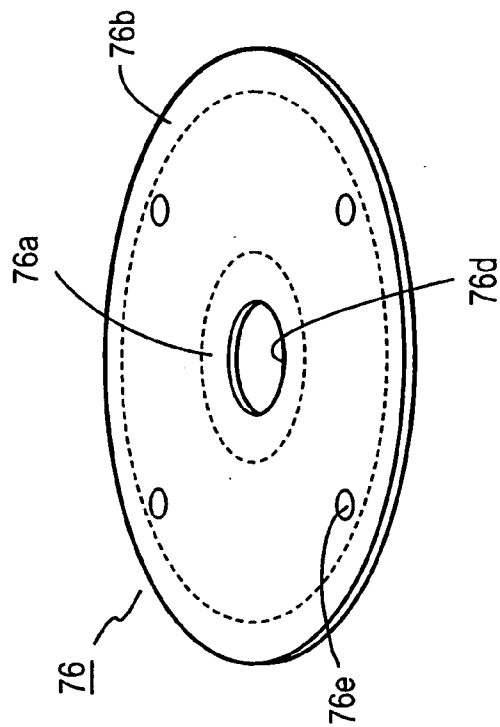

FIG. 31C



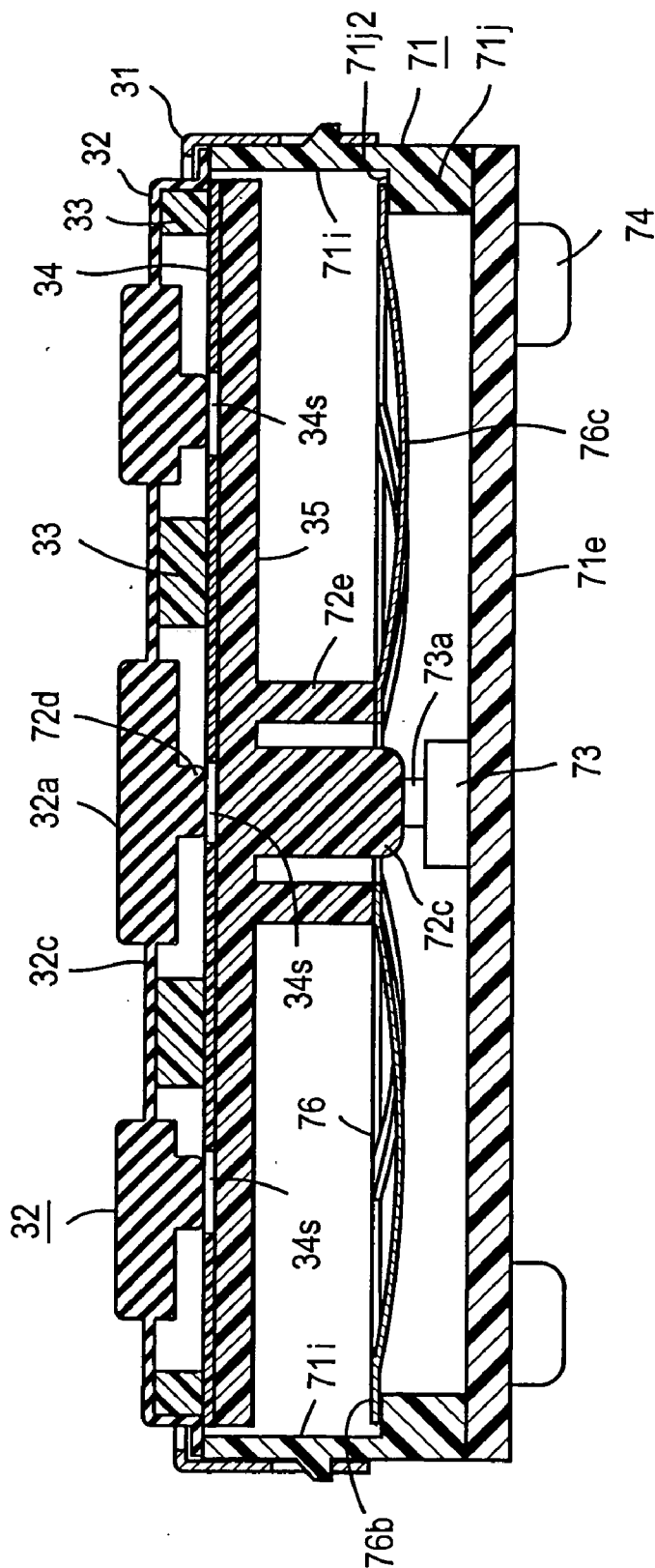

FIG. 32

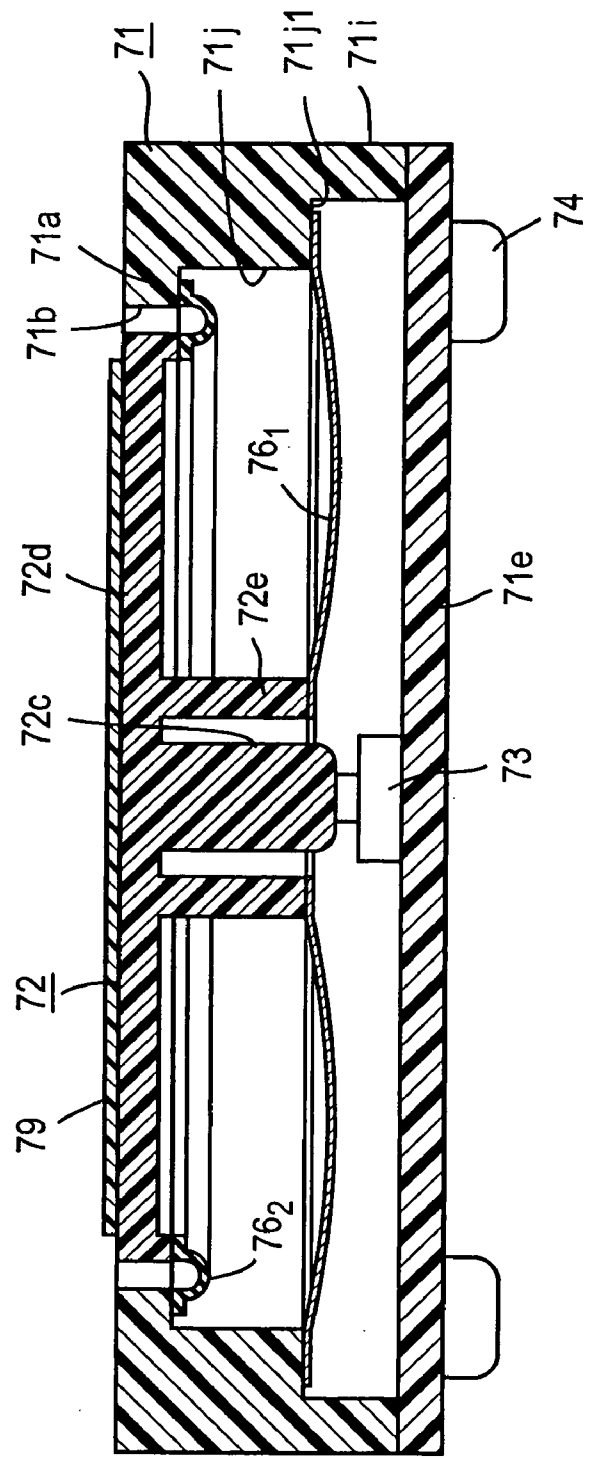

FIG. 33

DEPRESSION RESPONSIVE SWITCH UNIT

BACKGROUND OF THE INVENTION

[0001] The present invention relates to a depression responsive switch unit which is turned on in response to the depression of a knob.

[0002] A conventional depression responsive two-step switch unit which is disclosed in Japanese Laid-Open Patent Application No. 315,682/96 (laid open Nov. 29, 1996) will be briefly described with reference to **FIGS. 1, 2, 3A and 3B**. A rectangular case **2** includes a surface plate **2a**, in which a rectangular opening **2-1** is formed, and a key top **3** is disposed to substantially block the opening **2-1**. The key top **3** includes an elongate frame-shaped sidewall **3g**, on the inner surface of which a reinforcing plate **3c** is fitted and is secured in position by claws **3d**. A membrane sheet **6** is held in overlapping relationship with the front side of the reinforcing plate **3c**, and a surface sheet **3e** is disposed on the front side of the membrane sheet **6** and is adhesively bonded to the end face of the sidewall **3g** of the key top **3**.

[0003] A plurality of depression regions **3p** are defined in an array on the surface sheet **3e**, and are designated by key identification characters, which are numbers "1", "2", . . . , "8" in the example shown. Regions on the membrane sheet **6** which are located opposite to the depression regions **3p** are each designated as a membrane switch **6s**. Specifically, a pair of flexible films **6a** and **6b**, as may be formed by polyethylene films, are stacked together with a spacer **6c** therebetween to define a switch assembly for each depression region **3p**. In each switch assembly, fixed contacts **6d** and **6e** are formed on the film **6a** while a movable contact **6f** is formed on the film **6b** so as to be located opposite to the contacts **6d** and **6e**, thus completing the membrane switch **6s**.

[0004] Rotary shafts **3f** project externally from the opposite ends of the sidewall **3g** of the key top **3** and are rotatably engaged with bearings **2f** which are formed in the internal surface of the surface plate **2a** of the case.

[0005] When the depression region **3p** on the surface of the key top **3** is selectively depressed, the membrane switch **6s** which is located opposite thereto has its movable contact **6f** moved into contact with the both fixed contacts **6d** and **6e**, thus turning the switch on. As the key top **3** is further depressed, it moves angularly as shown in **FIG. 3B** and a pusher **3a** extending from one side of the sidewall **3g** of the key top **3** presses against a tact switch **7** which is mounted on the internal surface of a rear plate **2b** of the case **2**, thus turning it on.

[0006] When the key top **3** is released from the depression, a reaction which results from a resilient material within the tact switch **7** turns it off, and the restoring force of the flexible film **6b** causes the movable contact **6f** to move away from the fixed contacts **6d** and **6e** to turn the membrane switch **6s** off. A flexible band-shaped cable **8** on which external connection lead wires for the contacts of the membrane switches **6s** are formed by a printed circuit is taken out from the reinforcing plate **3c**.

[0007] A two-step switch which is constructed in the manner mentioned above finds its use in an application where a temporary input is selectively made initially and a true input is made after confirmation of the temporary input.

However, if an on-load is relatively high when an input is to be made to the first step switch, there is a likelihood that the second step switch may be turned on inadvertently. In a portable telephone or a vehicle onboard electrical instrument, a menu is displayed on a display screen, one of items in the menu is selected by a corresponding key, and on the basis of this selection, the display screen displays what item has been selected, and a user confirms this display, and if the display is proper, the user performs a key entry in order for that item to be truly selected. In this manner, it is possible for a user to try an entry by gently depressing a suitable key (depression region **3p**) without recognizing a key operation surface, which may be the display of switch identifications on the surface sheet **3e** in the example of **FIG. 1**, to know that one color among the menu items which corresponds to the display of the switch identification for the depressed key (depression region **3p**) has changed to red or that that item has been selected without requiring the visual recognition of the display of the switch identifications. If the selected item is different from an item which the user desires to select, the user may then depress another depression region **3p** gently. On the contrary, if the selected item were the item which the user intended to select, an entry for that item can be accomplished by further depressing the key. In other words, a selection from the menu can properly be accomplished without viewing the key operation surface, but while viewing only the display screen. By way of example, an operation of an onboard air conditioner, a control over CD player or DVD player, a selection of a radio channel to be received, a display of TV channel to be received or a display of an automatic road guide can be made while driving an automobile.

[0008] As mentioned above, the use of a two-step switch unit is greatly convenient in making a selection or exercising a control without a visual recognition of a key display surface or while performing a different task such as driving an automobile. In this instance, it would be understood that in order to provide a distinction between the first and the second step of the two-step entry and in consideration of the fact that there is a continued need to watch a particular direction such as looking forward when driving an automobile, it is preferred that a pressure that is required to make a temporary entry through the first step switch be small in magnitude. It is desirable that the first step switch can be operated with a pressure which is as weak as "tangibly feeling" the key display surface with a fingertip or "slipping" the fingertip along the key display surface.

[0009] However, in the conventional two-step switch unit cited above, there is a need to cause an elastic deformation of the surface sheet **3e** and the flexible film **6b** in order to turn on the first step switch or the membrane switch **6s**. This accompanies a reaction of an increased magnitude. In particular, polyethylene sheet or polycarbonate sheet is generally used for the surface sheet **3e**. A relatively thick sheet is used at this end because it is disposed on the surface and its damage upon contact with an external member must be avoided. Accordingly, the sheet itself has a high reaction, and thus there has been a disadvantage that the first step switch has a relatively high on-load. As a consequence, there have been occurrences that the second step switch becomes turned on as the first step switch is attempted to be turned on, as mentioned previously. It would be greatly convenient if an operation of the first step key switch which is required to select a given display on the display screen while viewing a

display condition, principally a display condition on the display screen of a portable telephone, a personal computer, a vehicle onboard instrument and the like could be achieved by tangibly feeling a key operation surface with a finger, for example, or by slipping the finger along the key operation surface. However, such has been a difficult task to achieve with a conventional two-step switch unit.

[0010] An example of a conventional depression responsive single step switch unit will be described below with reference to FIG. 23. This switch unit is disclosed in Japanese Patent No. 3,306,311 (issued Jul. 24, 2002). As a depressing piece 60 is depressed, a flexible sheet 61 becomes flexed, and a frame-shaped cushion member 62 as may be formed of urethane foam and on which the flexible sheet 61 is applied is increasingly squeezed, and a driving piece 63a of a driver 63 which is formed of a synthetic resin material and which is mounted on the internal surface of the flexible sheet 61 comes into contact with a click plate 64. When a load applied to the click plate 64 exceeds a given value, there occurs a reversal in the central portion of the click plate 64 as shown in FIG. 23B, whereby a membrane switch 6s is depressed to turn the switch on.

[0011] When the depressing piece is released from the depression, the flexible sheet 61 and the cushion member 62 which have undergone an elastic deformation return to their original configurations due to their respective resilience, and the click plate 64 also returns to its original configuration due to its resilient restoring force, whereby the switch assumes a turn-off condition. It is to be noted that a baseplate 65 is mounted on the surface of the frame-shaped cushion member 62 which is opposite from the flexible sheet 61 with the interposition of a sheet which defines the membrane switch 6s. In other words, the membrane switch 6s and the click plate 64 are secured to the baseplate 6s within an extent defined by the frame-shaped cushion member 62.

[0012] In the conventional depression responsive switch unit mentioned above, because the flexible sheet 61 on which the depressing piece 60 is mounted is secured to the cushion member 62, a drive to the click plate 64 may not take place in a satisfactory manner if a depressing force applied to the depressing piece 60 deviates from a direction which is perpendicular to the flexible sheet 61. Alternatively, if a depression is applied to one end of the depressing piece 60, the cushion member 62 will be strongly compressed toward the depressed end while it will be expanded toward the other end, causing the driver 63 to assume a relatively largely tilted position relative to the baseplate 65, preventing a drive from being transmitted satisfactorily to the click plate 64. In either instance, a load which is required to produce a reversal of the click plate 64 becomes higher than for a normal depression. This leads to problems that a clicking sensation is degraded, that a reversal may be prevented from occurring or that the useful life of the click plate 64 may be shortened.

[0013] Generally, a switch having a lower peak of on-load has a long useful life because the stresses to which the switch is subject in order to provide the clicking sensation and because the stresses to which the switch is subject from a return spring during the reversal are both small. However, if the reversal occurs as a result of a high load applied to the return spring which would occur during an edgewise depression, the return spring will be subject to correspondingly higher stresses, thus shortening the useful life.

[0014] Another example of conventional single step depression responsive switch unit will be described with reference to FIGS. 24 and 25. A depressing piece 72 faces externally through an opening 71b formed in a surface plate 71a of a case 71. When the depressing piece 72 is depressed into the case 71, a rib 72a formed on the peripheral surface of the depressing piece 72 is guided by a guide groove 71d of a tubular guide 71c which is integrally formed inside the case 71, thus moving toward a rear plate 71e of the case 71 in a direction perpendicular thereto. As a result of such movement, an actuator 73f of a tact switch 73 which is mounted centrally on the internal surface of the rear plate 71e is driven into a switch case 73b by a projection 72c which is formed centrally on the internal surface of a top plate of the depressing piece 72, whereupon an internal spring is reversed to turn the tact switch 73 on. When the depressing piece 72 is released from the depression, the original configuration is restored due to the resilient restoring force of the spring within the tact switch 73, and the depressing piece 72 is returned to its original position. It is to be noted that the rear plate 71e of the case 71 is detachable, and a screw 74 is passed through a bore 71f formed in the rear plate 71e and is screwed into a bore 71g formed in the end face of a sidewall 71i of the case 71, whereby the rear plate 71e is secured to the sidewall 71i.

[0015] With this conventional depression responsive switch unit, the depressing piece 71 moves in a direction perpendicular to the rear plate 71e if the depression is directed obliquely and if the depression is applied to one end of the depressing piece 71. However, a friction acting between the rib 72 and the guide groove 71d increases, and it becomes necessary to increase the depressing force. A switch operation may be prohibited for a depressing force of an equal magnitude. A problem relating to the sensation of operation remains in a similar manner as in the arrangement of FIG. 23. In addition, the arrangement may become larger in size because of a guide construction for the depressing piece 72.

[0016] It is an object of the present invention to provide a depression responsive switch unit which is capable of minimizing an on-load for a plurality of first step switches.

[0017] It is another object of the present invention to provide a depression responsive switch unit which is hardly influenced by a deviation in the direction of depression or a biased depression.

SUMMARY OF THE INVENTION

[0018] The present invention relates to a two step depression responsive switch unit in which a second step switch is interposed between a movable reinforcing plate and a case surface plate within a case and in which a plurality of first step switches are disposed on a case front side of the reinforcing plate. According to one aspect of the present invention, there is provided a knob which depresses the second step switch. The knob includes depressing pieces, each corresponding to the first step switch and formed on an elastic sheet which is extremely pliable as formed by a thermoplastic elastomer or silicone rubber. Each depressing piece has a depressed surface and also has a small projection which projects in the opposite direction from the depressed surface so as to move close to or into contact with a corresponding one of the first step switches. Each depressing

piece is located in an opening which is formed in a key operation base so as to receive a depressing piece. Each depressed surface is located outside the surface of the key operation base, and the reinforcing plate, the elastic sheet and the key operation base are held within the case so as to be simultaneously movable toward the rear plate of the case, and the marginal portion of the elastic sheet is secured to either one of the case, the key operation base and the reinforcing plate.

[0019] With this construction, when one of the depressing pieces is selected to be depressed gently, the elastic sheet is deformed (flexed) to turn one of the first step switches on. If the depression is further continued, the reinforcing plate moves to turn the second step switch on. The on-load of the first step switch principally comprises a reaction from only the elastic sheet which is extremely pliable. Since the elastic sheet is constructed with a thermoplastic elastomer or a silicone rubber, its reaction is considerably smaller as compared with the reaction of a single surface sheet which comprises polyethylene sheet or polycarbonate sheet used in the prior art. Accordingly, with the switch unit according to one aspect of the present invention, an operation of the first step switch can be made without any particular attention to a distinction between the operation of the first step switch and the operation for the second step switch, or without any need to be conscious not to operate the second step switch when the first step switch is to be operated. With the switch unit according to one aspect of the present invention, the first step switch can be turned on by tangibly feeling the key display surface with a finger or slipping the finger along the key display surface, for example.

[0020] According to another aspect of the present invention, there is provided a depression responsive switch unit in which a depression of a knob turns a switch on. According to this aspect of the present invention, the knob is disposed within an opening formed in a surface plate of a rigid body, and a switch is disposed between the knob and the case rear plate. The knob is retained in the case by a resilient member such that it is readily displaceable in the direction of a normal depression, but is hardly displaceable in a direction perpendicular to the direction of the normal depression.

[0021] In the switch unit according to the second aspect of the present invention, the case comprises a rigid body, and even though there is no guide means for the knob, the retaining function of the resilient member is such that if the direction of depression deviates from the normal direction, and if one end of the knob is depressed, the switch can be reliably turned on. In addition, a return spring has an increased useful life and could be constructed in a compact manner.

BRIEF DESCRIPTION OF THE DRAWINGS

[0022] FIG. 1 is a plan view showing an example of a conventional two-step switch unit;

[0023] FIG. 2 is a longitudinal section taken along the line II-II shown in FIG. 1;

[0024] FIG. 3A is an enlarged section taken along the line III-III shown in FIG. 1;

[0025] FIG. 3B is an enlarged section corresponding to FIG. 3A and illustrating when a tact switch 7 is turned on.

[0026] FIG. 4 is a cross section taken along the line IV-IV shown in FIG. 5 which illustrates a first embodiment of the present invention;

[0027] FIG. 5 is a top view of the first embodiment;

[0028] FIG. 6 is an exploded perspective view of the first embodiment;

[0029] FIG. 7 is a perspective view of the first embodiment before the cover is attached;

[0030] FIG. 8 is a cross section illustrating that the knob and the cover are positioned by bosses on the case in the first embodiment;

[0031] FIG. 9A is a cross section similar to FIG. 4, illustrating the first embodiment when the first step switch is turned on;

[0032] FIG. 9B is a cross section similar to FIG. 4, illustrating the first embodiment when the second step switch is turned on;

[0033] FIG. 10 is a cross section corresponding to FIG. 4 for a second embodiment;

[0034] FIG. 11 is a cross section taken along the line XI-XI shown in FIG. 12 illustrating a third embodiment of the present invention;

[0035] FIG. 12 is a top view of the third embodiment;

[0036] FIG. 13 is an exploded perspective view of the third embodiment as viewed from the front;

[0037] FIG. 14 is an exploded perspective view of the third embodiment as viewed from the rear;

[0038] FIG. 15 is a cross section taken along the line XV-XV shown in FIG. 12 for the third embodiment;

[0039] FIG. 16 is a cross section of the third embodiment taken along the line XVI-XVI shown in FIG. 12;

[0040] FIG. 17A is a cross section corresponding to FIG. 11, illustrating the third embodiment when the first step switch is turned on;

[0041] FIG. 17B is a cross section corresponding to FIG. 11, illustrating the third embodiment when the second step switch is turned on;

[0042] FIG. 18 is a cross section corresponding to FIG. 11, illustrating a fourth embodiment of the present invention;

[0043] FIG. 19A is a cross section of a modification of a knob 32 shown in FIG. 4;

[0044] FIG. 19B is a cross section of a modification of a knob 32 shown in FIG. 11;

[0045] FIG. 19C is a cross section showing another modification of a knob 32 shown in FIG. 11;

[0046] FIG. 19D is a cross section of a modification of a knob 32 shown in FIG. 18;

[0047] FIG. 19E is a cross section of another modification of a knob 32 shown in FIG. 18;

[0048] FIG. 20A is a cross section of a modification of the membrane switch 34s which serves as the first step switch in the first to the third mode of carrying out the invention;

[0049] FIG. 20B is a cross section of another modification of the first step switch used in the first to the third mode of carrying out the invention;

[0050] FIG. 20C is a cross section showing an exemplary first step switch in which the small projection 32b used in the first to the third mode of carrying out the invention also serves as a movable electrode;

[0051] FIG. 20D is a cross section of a modification of a first step switch shown in FIG. 20C;

[0052] FIG. 21 A is an exploded perspective view of a touch panel which serves as the first step switch in the first to the third mode of carrying out the invention;

[0053] FIG. 21 B is a cross section of a modification of the touch panel shown in FIG. 21A;

[0054] FIG. 22A is a cross section of a modification of the second step switch used in the first to the third mode of carrying out the invention;

[0055] FIG. 22B is cross section of another modification of the second step switch used in the first to the third mode of carrying out the invention;

[0056] FIG. 23A is a central longitudinal section showing a conventional single step depression responsive switch unit;

[0057] FIG. 23B is a cross section of a switch shown in FIG. 23A when it is turned on;

[0058] FIG. 23C is a cross section of the switch shown in FIG. 23A when it is edgewise depressed;

[0059] FIG. 24 is a central longitudinal section of another example of a conventional single step depression responsive switch;

[0060] FIG. 25 is an exploded perspective view of the switch unit shown in FIG. 24 as it is viewed from the rear side;

[0061] FIG. 26 is a cross section corresponding to FIG. 24, illustrating a fifth embodiment of the present invention;

[0062] FIG. 27 is an exploded perspective view of the embodiment shown in FIG. 26;

[0063] FIG. 28 is a cross section corresponding to FIG. 26, illustrating the fifth embodiment when the knob is edgewise depressed;

[0064] FIG. 29 is a cross section corresponding to FIG. 28 illustrating a result of an edgewise depression where a resilient member 76 shown in FIG. 26 is omitted;

[0065] FIG. 30 is a cross section corresponding to FIG. 26, illustrating a sixth embodiment of the invention;

[0066] FIG. 31A is a central cross section showing a modification of the resilient member 76 used in the fourth mode;

[0067] FIG. 31B is a perspective view of the resilient member shown in FIG. 31A;

[0068] FIG. 31C illustrates another modification of an elastic deformation member 76;

[0069] FIG. 32 is a cross section corresponding to FIGS. 4 and 26 and illustrating an embodiment in the fifth mode of carrying out the present invention; and

[0070] FIG. 33 is a cross section corresponding to FIG. 26, schematically illustrating the embodiment in the fifth mode of carrying out the present invention.

DESCRIPTION OF MODES OF CARRYING OUT THE INVENTION

First Mode of Carrying out the Invention

[0071] A first mode of carrying out the present invention is a depression responsive two-step switch unit in which the marginal portion of the elastic sheet is carried by a case.

[0072] The first mode of carrying out the present invention will be briefly described with reference to FIG. 4. In the example shown, a second step switch 36 is disposed on a rear plate 39h within a case 39 and a reinforcing plate 35 is disposed on top of the second step switch 36. A plurality of first step switches 34s are disposed on the reinforcing plate 35. A key operation base 33 is disposed on the side of the reinforcing plate 35 which is located toward the first step switch 34s. At locations corresponding to each of the first step switches 34s, the key operation base 33 is formed with depression openings 33a extending therethrough. A knob 32 is disposed on the front side of the key operation base 33.

[0073] The knob 32 includes depressing pieces 32a which are formed on an extremely pliable elastic sheet 32c which comprises a thermoplastic elastomer or a silicone rubber at locations corresponding to one of the first step switches 34s, and each depressing piece 32a has a depressed surface 32a2 which is located forwardly of the elastic sheet 32c. Each depressing piece 32a is at least partly located within the depression opening 33a formed in the key operation base 33 and includes a small projection 32b which projects from the surface opposite from the depressed surface 32a2. Each small projection 32b is located close to or is in contact with a corresponding one of the first step switches 34s. The marginal portion 32d of the elastic sheet 32c is retained by the case 39. In the example shown, the case 39 comprises a rear plate 39h, sidewalls 39a and 39d which are integral therewith, and a cover 31 which abuts against and which is secured to the end faces of the sidewalls 39a and 39d to serve as a front plate. The marginal portion 32d of the elastic sheet 32c is held sandwiched between the cover (front plate) 31 and the sidewall 39a to be retained by the case 39.

[0074] The knob 32 and the key operation base 33 are secured together as are the first step switches 34s and the reinforcing plate 35, whereby they are simultaneously reciprocable with respect to the rear plate 39h. In the example shown, the second step switch 36 is constructed to be automatically reset when it is released from the depression or assumes a turn-off condition while desirably providing a clicking sensation or a sensation that a switch operation has been made.

First Embodiment

[0075] A first embodiment as a specific example of the first mode of carrying out the present invention will now be described. It should be understood that in the description to follow, corresponding parts which appear throughout the drawings are designated by like reference numerals in order to avoid a duplicated description as much as possible.

[0076] A cross section of the first embodiment taken along the line IV-IV shown in FIG. 5 is shown in FIG. 4, a plan view is shown in FIG. 5, and the exploded perspective view is shown in FIG. 6.

[0077] A cover (front plate) **31** comprises a metal sheet which is machined as required, and includes a square portion **31a** in which a circular opening **31b** is formed. Each side of the square portion **31a** has a U-shaped detent **31c** having short limbs which is bent in a direction perpendicular to the square portion **31a** to extend toward the rear plate **39h**.

[0078] A knob **32** comprises a square-shaped elastic sheet **32c**, which extends outside the opening **31b** formed in the cover **31** except for its marginal portion **32d** to define a circular top surface on which five depressing pieces **32a** are formed as projections in this example. One of the depressing pieces **32a** which is located centrally has a circular configuration, while the depressing pieces **32a** which are located laterally on the opposite sides of the central depressing piece **32a** are triangular in configuration. The internal surface of each depressing piece **32a** projects beyond the elastic sheet **32c** toward the rear plate **39h** as shown in FIG. 4, and a small projection **32b** is formed centrally on the end face of the projection. In this example, the depressing piece **32a**, the small projection **32b** and the elastic sheet **32c** are integrally molded with a thermoplastic elastomer, and thus is constructed with an extremely pliable material.

[0079] The key operation base **33** is molded from a hard resin such as ABS resin or polycarbonate and is in the form of a disc which corresponds to the circular top surface of the knob **32**. The key operation base **33** is formed with depression openings **33a** which extend therethrough at locations corresponding to each depressing piece **32a** of the knob **32** and which are larger than the depressing piece **32a**. The centrally disposed depression opening **33a** is circular in the similar manner as the depressing piece **32a** which corresponds thereto while the remaining depression openings **33a** are triangular in configuration. While the key operation base **33** and the knob **32** are shown separately in FIG. 6, in the present example, they are integrally molded, and the elastic sheet **32c** is secured to the key operation base **33** without any slack therebetween.

[0080] In the present example, the first step switch **34s** uses a membrane sheet **34** which is constructed in the similar manner as the membrane sheet **6** of the prior art described above in connection with FIGS. 1 to 3. While not specifically shown in FIGS. 4 to 7, the five membrane switches acting as first step switches **34s** are formed, each constructed in the similar manner as the membrane switch **6s** shown in FIG. 3A and having fixed contacts **6d** and **6e** and the movable contact **6f**. In FIG. 4, such first step switches (membrane switches) **34s** are indicated by blank areas (the same is true for a corresponding membrane switch). A tail **34a** which is used to take out the lead wire for each of the first step switches **34s** is connected to part of the peripheral edge of the membrane sheet **34**.

[0081] A reinforcing plate **35** comprises a stainless steel sheet, for example, and has substantially similar configuration as the membrane sheet **34**.

[0082] The second step switch **36** shown in this example comprises a switch body **36s** which is constructed in the similar manner as the membrane switch **36s** shown in FIG. 3, for example, a click plate **37** and a pusher **38**. The membrane sheet **40** on which the membrane switch **36s** acting as a switch body is constructed is shown in FIG. 6 as being separate from the membrane sheets **34**, but they are integrally formed through a connector **40a** as shown in FIG.

4, and the connector **40a** is folded to place the membrane sheets **34** and **40** on the opposite sides of the reinforcing plate **35**. The membrane sheet **36s** acting as the switch body is also shown as a blank area in FIG. 4 (the same applies for a similar switch).

[0083] In the present example, an arrangement is made to provide a clicking sensation from a switch operation of the second step switch **36** in a manner mentioned previously, and the click plate **37** is disposed in the region of the membrane switch (switch body) **36s** of the membrane sheet **40** on the opposite side of the reinforcing plate **35**. The click plate **37** comprises a dish-shaped springy metal sheet.

[0084] A pusher **38** is interposed between the click plate **37** and the rear plate **39h** so that a restoring force acts automatically when the second step switch **36** is released from the depression. The pusher **38** may be formed of rubber, for example, and has a square-shaped flat plate **38a** which is centrally formed with a dome **38b** which projects toward the rear plate **39h**. A projection **38c** is formed centrally on the internal surface of the dome **38b** so as to project toward the click plate **37**.

[0085] The case **39** is formed of a hard resin such as ABS resin or polycarbonate and is open toward the front, and is in the form of a shallow square, with each corner being rounded. The sidewall **39a** which forms one side of the square is somewhat extended externally, and a notch **39b** is formed in its end face which is disposed toward the front side. This illustrates an arrangement to allow the tail **34a** to be guided externally. In order to fasten the case **39** and the cover **31** together, a pair of small detent tabs **39c** are formed on the external surface of the sidewall **39a** while the external surface of the sidewalls **39d**, which form the remaining three sides of the square, is formed with a detent projection **39e** of a substantial length which extends along the respective side.

[0086] In order to allow the knob **32** to be positioned when mounting it on the case **39**, in the present example, a boss **39f** is fixedly mounted on the rear plate **39h** at a location close to the internal surface of each rounded corner of the case **39**. The marginal portion **32d** of the knob **32** and the top plate **31a** of the cover **31** are formed with openings **32f** and **31e**, respectively, through which the bosses **39f** can be passed. A boss **39g** is formed centrally on the notch **39b** of the case **39** on its front side, and an opening **34b** is formed in an end of the membrane sheet **34** which is located toward the tail **34a** for passing the boss **39g**. It is to be noted that openings **31f**, which are formed radially outward of the four openings **31e** in the cover **31** are used for purpose of mounting the two-step switch unit.

[0087] In order to position and secure the membrane sheet **34** of the key operation base **33** and the reinforcing plate **35** relative to each other, a pair of bosses are formed on the key operation base **33** on the side which faces the rear plate **39h** in this example, even though such bosses are hidden from sight in FIG. 6, and the membrane sheet **34** and the reinforcing plate **35** are formed with a pair of openings **34c** and **35a**, respectively, for passing these bosses.

[0088] In order to position and secure the membrane switch (switch body) **36s** of the membrane sheet **40**, the click plate **37** and the pusher **38** relative to each other, in the present example, the flat plate **38a** of the pusher **38** is formed with a pair of bosses **38d**, and openings which pass these

bosses **38d** are formed in the reinforcing plate **35**, the membrane sheet **34** and the key operation base **33**. Numerals **34d** and **33b** shown in **FIG. 6** shows such openings. It should be noted that the openings formed in the reinforcing plate **35** for passing the bosses **38d** are hidden from sight.

[0089] The assembly of parts mentioned above will now be described.

[0090] Initially, the assembly of the knob will be sequentially described.

[0091] (1) As mentioned previously, the knob **32** and the key operation base **33** are integrally formed as a result of their molding, and the membrane sheet **34** and the reinforcing plate **35** are secured on the rear side of the key operation base **33**. This securing operation takes place by passing the bosses which are formed on the rear side of the key operation base **33** into the pair of openings **34c** formed in the membrane sheet **34** and through the pair of openings **35a** formed in the reinforcing plate **35** and by caulking the free ends of the bosses by heat. This assembly will be more apparently seen by reference to **FIG. 15** which illustrates a similar assembly which takes place in a third embodiment to be described later.

[0092] (2) The membrane sheet **40** which is integral with the membrane sheet **34** is secured to the rear side of the reinforcing plate **35** by using a both side adhesive, for example, to adhesively secure them.

[0093] (3) The click plate **37** is disposed on the rear side of the membrane sheet **40** with its center aligned with the position of the membrane switch **36s** in a manner such that the rear side is convex. The click plate **37** is positioned and secured to the membrane sheet **36** as by covering it with an adhesive tape, for example.

[0094] (4) The pusher **38** is disposed on the rear side of the click plate **37**. The pusher **38** has a pair of bosses **38d**, which are sequentially passed through openings in the reinforcing plate **35**, the openings **34d** in the membrane sheet **34** and the openings **33b** in the key operation base **33** to be a press fit therein, whereby the pusher **38** is positioned relative to the click plate **37** and is secured to the key operation base **33**. This completes the assembly of the knob.

[0095] Subsequently, the knob assembly is assembled into the case **39**. This assembling operation takes place by passing the bosses **39f** on the case **39** through the four openings **32f** formed in the marginal portion **32d** of the knob **32** and passing the boss **39g** on the case **39** through the opening **34b** formed in the membrane sheet **34**. In this manner, the knob assembly is positioned and received within the case **39**. **FIG. 7** shows this condition.

[0096] Finally, the cover **31** is attached to complete the two-step switch unit. The cover **31** is attached by engaging four detents **31c** with the detent projections **39c** and **39e** of the case **39**.

[0097] **FIG. 8** shows, to an enlarged scale, one location where the marginal portion **32d** of the knob **32** and the square portion **31a** of the cover **31** are positioned by the bosses **39f** on the case **39**. The cover **31** is positioned by passing the opening **31e** thereof over the boss **39f**, and the periphery of the knob **32** or the marginal portion **32d** of the elastic sheet **32c** is held sandwiched between the case **39** and the surface plate or the cover **31** to be retained by the case **39**.

[0098] In the example shown in **FIG. 8**, a ring-shaped rib **32g** is formed around the opening **32f** in the periphery of the knob **32** (or the marginal portion of the elastic sheet) **32d** on the side which faces the cover **31**, and the square portion **31a** of the cover **31** abuts against the marginal portion **32d** of the knob **32** only at this ring-shaped rib **32g** while a small clearance is maintained with respect to the marginal portion **32d** in the remainder.

[0099] The two-step switch unit which is assembled in the manner mentioned above has a construction as shown in **FIG. 4** where the pusher **38** is located centrally on the internal surface of the rear plate **39h** of the case **39**, and the click plate **37**, the reinforcing plate **35** which carries membrane sheets **34** and **36** on the opposite sides and the key operation base **33** which is integral with the knob **32** are sequentially mounted thereon.

[0100] The knob **32** or the elastic sheet **32c** thereof is disposed on the front side of the key operation base **33** and its marginal portion **32d** is supported by the case **39**, substantially blocking the opening in the case **39** by the knob **32**. In this example, it is secured to the case **39** at a plurality of locations (which are four locations as shown), and other non-anchored portions remain to be free ends.

[0101] The operation of the two-step switch unit according to the first embodiment will now be described. When any desired one of the depressing pieces **32a** of the knob **32**, for example, a central depressing piece is gently depressed, the elastic sheet **32c** located around this depressing piece **32a**, namely, the portion of the elastic sheet **32c** which is located between the peripheral edge of the depression opening **33a** and the depressing piece **32a** becomes flexed as shown in **FIG. 9A**, thus depressing the small projection **32b**. The membrane switch **34s** which serves as the first step switch is depressed by the small projection **32b**, whereby the contacts (not shown) which are located opposite thereto contact each other to turn the first step switch **34s** on.

[0102] When the depressing piece **32a** is further depressed, the marginal portion **32d** of the knob **32** becomes flexed as shown in **FIG. 9B**, and the key operation base **33** which is integral with the knob **32**, the reinforcing plate **35** which holds the membrane sheets **34** and **40** and the click plate **37** are depressed in an integral manner, thus depressing the pusher **38**.

[0103] The dome **38b** of the depressed pusher **38** is squeezed to deform in a manner shown in **FIG. 9B**, whereby the projection **38c** of the pusher **38** presses against the click plate **37**. The click plate **37** which is pressed in this manner has its central portion reversed in position relative to the peripheral surface of the click plate **37** (hereafter such phenomenon will be simply referred to as a reversal) with a click sensation, thus pressing against the membrane switch **36s** which serves as the switch body of the second step switch. When the click plate **37** presses against the membrane switch **36s**, the contacts (not shown) which are located opposite thereto contact each other to turn the second step switch **36** on.

[0104] When this pressing action is gradually released, the resilient restoring force of the pusher **38**, the click plate **37** and the marginal portion **32d** of the knob **32** causes the parts which have been depressed in an integral manner to return to their original positions to turn the second switch **36** off.

When the depression is completely released, the depressing piece **32a** and the small projection **32b** return to their original positions relative to the key operation base **33** under the influence of the restoring force of the membrane sheet **34** to turn the first step switch **34s** off.

[0105] In the present example, the membrane switch **34s** which serves as the first step switch is disposed within the switch unit, and accordingly, contacts can be formed on a very thin film, for example, a polyethylene film by a printed circuit technology, allowing the reaction thereof to be minimized. In addition, since the first step switch is turned on by a flexure of only the elastic sheet **32c** which comprises a pliable thermoplastic elastomer, the on-load of the first step switch can be minimized. More specifically, in the two-step switch unit of this embodiment, the key operation surface is constructed by the key operation base **33** which retains the knob **32**, and accordingly, the first step switch can be turned on with a contact of the finger with the depressing piece which is on the order of tangibly feeling the key operation surface with the finger. In addition, the profile of the knob **32** is maintained by the key operation base **33** without any likelihood of being damaged upon contact with an external member while maintaining the key operation surface.

[0106] In addition, the switch bodies of the first and the second step switch are both formed by the membrane sheets **34** and **40**, respectively, in the present example, allowing a thin and compact construction while reducing the number of steps of assembly to permit the switch unit to be constructed inexpensively.

[0107] Furthermore, in the example shown, the peripheral portion of the elastic sheet **32c** or the marginal portion **32d** of the knob **32** is not secured to the case **39** along the full perimeter thereof, but is secured by being positioned at a plurality of points which are four points representing the bosses **39f** of the case **39** in this example, whereby a construction is achieved which allows an elastic deformation of the marginal portion **32d** to occur readily in the direction of depression while making an elastic deformation in a direction perpendicular to the direction of depression or in a direction parallel to the rear plate **39h** hardly occurring. In other words, the knob **32**, the key operation base **33** and the reinforcing plate **35** are readily displaceable in the direction of a normal depression, but are hardly displaceable in a direction perpendicular to the direction of a normal depression. Thus, when the knob **32** is depressed, an adequate degree of tension occurs in the marginal portion **32d** as a result of securing at a plurality of points which are four points in the present example, and if another depressing piece **32a** is depressed, or if the knob **32** is edgewise depressed, a rotation of the key operation base **33** about the point of contact between the pusher **38** and the rear plate **39h** is unlikely to occur. In addition, if the knob **32** were depressed obliquely with respect to the direction of a normal depression, the second step switch can be depressed under a condition that the key operation base **33** assumes a small inclination, affording a good touch and an evenly stroking sensation at this point. In addition, because the key operation surface is defined by the knob **32** of an elastic material which comprises a thermoplastic elastomer, additional effects are obtained that it is comfortable to touch and there is a high grade leather-like appearance.

Second Embodiment

[0108] In the second embodiment, in order to reduce the number of parts, a sidewall **39a** is molded integrally with a knob **32** as shown in FIG. 10, and the marginal portion **32d** of the elastic sheet **32c** (knob **32**) is secured to the end face of the sidewall **39a** along the full perimeter as by an integral molding. A redundant portion **32h** which is U-shaped in section is formed in the marginal portion **32d** of the elastic sheet **32c** (knob **32**) to extend along the inner periphery of the sidewall **39a**. This facilitates an elastic deformation of the marginal portion **32d** in a direction toward the rear plate and also makes an elastic deformation in a direction parallel to the rear plate more difficult to occur. In other words, the knob **32**, the key operation base **33** and the reinforcing plate **35** are readily displaceable in the direction of a normal depression and are hardly displaceable in a direction perpendicular to the direction of a normal depression. Accordingly, if the knob **32** is edgewise depressed, there occurs no inclination of the knob **32** (the key operating base **33** and the reinforcing plate **35**), allowing the second step switch to be operated with a good touch and an evenly stroking sensation. It is to be noted that in the present example, the rear plate **39h** of the case **39** is formed by a metal sheet in order to reduce the thickness. Securing the marginal portion **32d** of the elastic sheet **32** to the case **39** over the full perimeter may take place in the example shown in FIGS. 4 to 8 by omitting the ring-shaped rib **32g** shown in FIG. 8 and holding the marginal portion **32d** sandwiched between the case **39** and the cover **31** over the full perimeter.

[0109] The example shown in FIG. 10 illustrates that the depressing piece **32a** and the small projection **32b** of the knob **32** are integrally constructed with a resin material. Specifically, the elastic sheet **32c** is formed with a passing opening **32i** in a manner corresponding to each depressing piece **32a**, and each depressing piece **32a** is formed by a hard resin such as ABS resin or polycarbonate, with a flange **32a1** integrally formed with the depressing piece **32a** toward a depressed surface **32a2** and each depressing piece **32a** is passed through the corresponding passing opening **32i** and the flange **32a1** is brought into abutment against the elastic sheet **32c** around the edge of the passing opening **32i**. In the present example, a surface opposite from the surface against which the flange **32a1** around the edge of the passing opening **32i** abuts is integrally molded with a ring-shaped rib **32c1**. The elastic sheet **32c1** which comprises a thermoplastic elastomer, and the depressing piece **32a** and the small projection **32b** which comprise a hard resin are integrally molded to be secured together. By choosing a resin material for the depressing piece **32a**, a desired feeling as the depressing piece **32a** is touched when it is to be depressed can be obtained.

[0110] In the example shown in FIG. 10, the pusher **38** shown in FIG. 4 is omitted, and a projection **39i** is integrally formed at the center of the internal surface of the rear plate **39h**, with the projecting end face of the projection abutting against the central portion of the convex side of the click plate **37**. It will be seen that in this instance also, as one of the depressing pieces **32a** is depressed, the click plate **37** is pressed by the projection **39i** to reverse, whereby the switch body **36s** of the second step switch is turned on.

Second Mode of Carrying Out the Invention

[0111] The second mode of carrying out the present invention is distinct from the first mode of carrying out the

invention in that a key operation base **33** is disposed on the front side of an elastic sheet **32c** and that the elastic sheet **32c** is retained not by the case, but by the key operation base **33** and a reinforcing plate **35**, as indicated in **FIG. 11**, for example, which illustrates a cross section corresponding to **FIG. 4**. Specifically, the key operation base **33** is formed with a depression opening **33c** in a manner corresponding to each depressing piece **32a**, and the depressing piece **32a** faces the front side from within the case **39** through the respective depression opening **33c**. In **FIG. 11**, a depressed surface **32a2** which is configured to be similar to a part of a spherical surface projects externally from the surface of the key operation base **33**. There is a close clearance between the peripheral surface of the depressing piece **32a** and the depression opening **33c**, and the key operation surface is formed by the surface of the key operation base **33** and the depressed surface **32a2** which substantially blocks the depression opening **33c**. An operator of the two-step switch unit touches the key operation surface with a finger of his hand to operate it for depression. It is not the key operation base **33**, but the elastic sheet **32c** that contacts the reinforcing plate **35** or the membrane sheet **34**. The marginal portion **32d** of the elastic sheet **32c** is held sandwiched between the key operation base **33** and the reinforcing plate **35** to maintain the elastic sheet **32c** in a slack-free condition. In other respects, the second mode of carrying out the invention may be fundamentally same as in the first mode of carrying out the invention. A specific example of the second mode of carrying out the invention will now be described as a third embodiment.

Third Embodiment

[0112] The third embodiment is shown in **FIGS. 11** to **16**. In the third embodiment, instead of the cover **31** shown in the first embodiment, a case **39** is formed with a surface plate **39j** in an integral manner with its sidewall, and a large circular opening **39k** is formed in the surface plate **39j**. A key operation base **33** is disposed to substantially block the opening **39k**, and the key operation base **33** is formed with a depression opening **33c** in a manner corresponding to each depressing piece **32a**. In the present example, there are nine depression openings **33c** as shown in **FIG. 12**, one being disposed at the center while the remaining eight openings are disposed on a common circle at an equal interval.

[0113] As mentioned previously, in the present example, the depressing piece **32a** and the small projection **32b** are integrally molded with a hard resin, and this is adhesively secured to or integrally molded with the elastic sheet **32c** which comprises a thermoplastic elastomer **32**. Each depressing piece **32a** is disposed in the depression opening **33c** in the key operation base **33** to face the exterior. Only a depressed surface **32a2**, which forms a part of spherical surface, is slightly exposed from the surface of the key operation base **33** to permit a finger to contact and to slip along the key operation surface so that the existence of the depression piece **32a** can be confirmed by tactile impression. The elastic sheet **32c** is located on the reinforcing plate **35** through the membrane sheet **34** interposed in this instance, and has the small projection **32b** as the only portion where it contacts a first step switch, which is a membrane switch **34s** within a membrane sheet **34** in this example.

[0114] For this reason, an air gap formation **32j** is formed as a projection on the side of the elastic sheet **32c** which is

disposed toward the reinforcing plate **35** in a manner corresponding to each adjacent small projection **32b** or to the center position between adjacent membrane switches **34s**, thus producing an air gap **41** between the elastic sheet **32c** and the first step switch (membrane switch) **34s**. As shown in **FIGS. 11, 14** and **16**, the air gap formation **32j** is located at a midpoint between adjacent depressing pieces **32a** as viewed in the direction in which the depressing pieces **32a** are arrayed. The marginal portion **32d** of the elastic sheet **32c** has an increased thickness and defines a ring-shaped air gap formation which is centered about the centrally located depressing piece **32a**.

[0115] As a result of abutment of these air gap formations **32j** against the membrane sheet **34**, the small projection **32b** moves close to or contacts the membrane switch **34s**. In this example, the reinforcing plate **35** comprises a molding of a hard resin such as ABS resin or polycarbonate. As shown in **FIGS. 13** and **14**, the key operation base **33** is integrally formed with a plurality of bosses **33d** as projections on the rear side thereof, and these bosses **33d** are sequentially passed through openings **32k** formed in the elastic sheet **32c**, openings **34c** formed in the membrane switches **34s** and openings **35a** formed in the reinforcing plate **35** in a manner shown in **FIG. 15**, and their projecting ends are caulked by heat. In other words, heat and pressure are applied to increase the cross section of the bosses, and these portions are engaged with portions of the openings **35a** which have a greater diameter. In this manner, the key operation base **33**, the knob **32**, the membrane switches **34s** and the reinforcing plate **35** are positioned relative to each other and are also secured together.

[0116] As shown in **FIG. 11**, a spacing between the air gap formation on the marginal portion **32d** of the elastic sheet **32c** and the closest small projection **32b** is substantially equal to a spacing between that smaller projection **32b** and the air gap formation **32j** which is located on the other side from the marginal portion **32d** and which is closest thereto. Unification of the key operation base **33**, the membrane switches **34s** and the reinforcing plate **35** by caulking of bosses under heat which take place in the first embodiment mentioned above takes place in the similar manner as unification of the key operation base **33**, the knob **32**, the membrane switch **34s** and the reinforcing plate **35** by caulking of bosses under heat in the third embodiment.

[0117] In the present example, a tact switch is used for the second step switch **36**. The tact switch **36** includes an internal resilient member which is reversed in configuration when an actuator **36a** is depressed into a switch case **36b** by an external force to assume a switch-on condition. The reversal of the resilient member provides a tactile impression (clicking sensation) of a switch operation. When the actuator **36a** is released from the external force, the resilient restoring force restores the configuration of the resilient member, thus resuming a switch-off position. The tact switch **36** is disclosed, for example, in Japanese Utility Model Registration No. 2,557,784 (issued Dec. 17, 1997).

[0118] The tact switch **36** is secured centrally on the internal surface of the case rear plate **39h**, for example, at a predetermined position which is previously marked when the rear plate **39h** is formed. As shown in **FIGS. 11, 15** and **16**, the projecting end face of the actuator **36a** of the tact switch **36** is abutted by the reinforcing plate **35**, which is an

integrally formed projection **35b** in the present example. The resilient restoring force of the resilient member contained in the tact switch **36** acts through the actuator **36a** to push back the reinforcing plate **35** toward the surface plate **39j** of the case **39** until a flange **33e** disposed around the outer periphery of the key operation base **33** abuts against the internal surface of the surface plate **39j**. The peripheral edge of the disk-shaped key operation base **33** is folded toward the rear side to extend through a small distance, and the flange **33e** is integrally formed around the outer periphery of such extension **33f**.

[0119] In the present example, the case **39** is integrally molded with the sidewall of the surface plate **39j**, as mentioned previously, allowing the rear plate **39h** to be detachable. As shown in FIGS. 11, 13 and 14, a notch **39m** is formed in one side of the rear plate **39h**, allowing the membrane sheet tail **34a** to be led out. After the key operation base **33**, the knob **32**, the membrane switches **34s** and the reinforcing plate **35** are unified in a manner mentioned previously, these are inserted into the case **39** from the rear side, the rear plate **39h** is brought into abutment against the end face of the sidewall of the case **39** as illustrated in FIG. 11, screws **42** are inserted into openings **39n** formed in the rear plate **39h** as shown in FIGS. 13, 14 and 16, and when the screws **42** are clamped into bores **39p** which are formed in the case sidewall, the rear plate **39h** is unified with the case.

[0120] A printed circuit board is used for the rear plate **39h**. A position marker (not shown) which is applied when forming the printed circuit may be utilized when mounting the tact switch **36** with a face bond. As shown in FIG. 11, the tail **34a** of the membrane sheet is taken out through the notch **39m** and is connected to a connector **43** which is mounted on the outer surface of the rear plate **39h**. While the connector **43** has not been shown in the first and the second embodiment, it is a general practice that the tail **34a** of the membrane sheet is connected to a connector which is mounted on the outer surface of the case **39**, as illustrated in FIG. 11.

[0121] In the third embodiment, when one of the depressing pieces **32a** is depressed into the case **39**, a portion of the elastic sheet **32c** which lies between that depressing piece **32a** and the air gap formation **32j** which is close thereto undergoes an elastic deformation (becomes flexed) initially, as shown in FIG. 17A, and a corresponding one of the first step membrane switches **34s** is depressed to be turned on. The on-load which occurs at this time can be reduced to a very low level in the similar manner as in the first mode of carrying out the invention, because such load accrues from only the reactions of the elastic sheet **32c** which has an extremely high pliability and the membrane switch **34s**.

[0122] When the depressing piece **32a** continues to be depressed into the case **39**, the reinforcing plate **35** moves toward the rear plate **39h** against the reaction from the actuator **36a** of the tact switch **36**, as shown in FIG. 17B, whereby the actuator **36a** is driven into the switch case **36b** to turn the second step switch **36** on with a clicking sensation. When the depressing piece **32a** is released from the depression, the resilient restoring force of the resilient member within the tact switch **36** causes the reinforcing plate **35** to move toward the surface plate **39j**, turning the second step switch **36** off, and the membrane switch **34s** or

the first step switch which has been turned on is turned off again by the restoring force of the elastic sheet **32c**.

[0123] In the second mode of carrying out the invention, the marginal portion **32d** of the elastic sheet may be carried by the reinforcing plate **35** as by being adhesively bonded thereto, for example.

Third Mode of Carrying out the Invention

[0124] In the third mode of carrying out the invention, the elastic sheet itself represents the surface of the case or the key operation surface, and the marginal portion of the elastic sheet is retained by the case and the key operation base. As illustrated by a section corresponding to FIG. 4 in FIG. 18, for example, a knob **32** faces the exterior through an opening **39k** in a surface plate **39j**, a key operation base **33** is disposed on the rear side of the knob, and a marginal portion **32d** of the elastic sheet **32c** is retained by a marginal portion of the key operation base **33**. Disposed on the rear side of the key operation base **33** is a reinforcing plate **35** on which a first step switch **34s** is disposed, and a second step switch means **36** is interposed between the reinforcing plate **35** and a rear plate **39h**. In other words, as compared with FIG. 11, the knob **32** and the key operation base **33** are interchanged in position. A specific example of the third mode of carrying out the invention will now be described in terms of a fourth embodiment.

Fourth Embodiment

[0125] A fourth embodiment is shown in FIG. 18. In the fourth embodiment, a key operation base **33** which is configured in substantially the same manner as the key operation base **33** used in the third embodiment is employed, and a knob **32** is disposed in abutment against the front surface of the key operation base **33**. The knob **32** which is shown in this example has a depressing piece **32a** and a small projection **32b** which are integrally molded from a hard resin in the similar manner as the knob shown in FIG. 10. Each depressing piece **32a** is passed through a passing opening **32i** formed in an elastic sheet **32c** which comprises a thermoplastic elastomer, and a flange **32a1** which is formed around the periphery of the surface of the depressing piece **32a** is adhesively bonded to the elastic sheet **32c**. A depressed surface **32a2** inclusive of the flange **32a1** is in the form of part of a spherical surface.

[0126] Each depressing piece **32a** is passed through a depression opening **33c** in the key operation base **33**, and the elastic sheet **32c**, while being in abutment against the front side of the key operation base **33** without any slack, extends along the outer peripheral surface of an extension **33f** of the key operation base **33**, and further extends along the front side of the flange **33e** in its marginal portion **32f**, which is in turn retained by the marginal portion of the key operation base **33** or the flange **33e** in the present example. By way of example, the knob **32** may be integrally molded with respect to the molded key operation base **33**. Alternatively, the marginal portion **32f** may be adhesively secured to the flange **33e**.

[0127] Each depressing piece **32a** is passed through the depression opening **33c** in the key operation base **33**. The depression opening **33c** is a concentric circle centered about the depressing piece **32a**, and a spacing between an inner peripheral surface of the depression opening **33c** and the

peripheral surface of the depressing piece **32a** is chosen to be a certain size so that a region of the elastic sheet **32c** which is disposed therebetween can readily be flexed if the depression applied to the depressing piece **32a** is very weak, and assumes substantially same value for the spacing. Each small projection **32b** for each depressing piece **32a** is in contact with or lies close to the first step switch, which is the membrane switch **34s** in the present example, in the same manner as in the described embodiments. In other words, the fourth embodiment is distinct from the second embodiment principally in the manner of retaining the elastic sheet **32c**. It should be understood that the unification of the key operation base **33** and the reinforcing plate **35** takes place in the similar manner as in the third embodiment.

[0128] In the present example, the membrane switch **36s** is used for the second step switch means **36**, and this is mounted on the internal surface of the rear plate **39h**. Specifically, the membrane switch **34s** which serves as the first step switch is extended to form the membrane sheet **40** inclusive of the second step switch **36s**, in the similar manner as in the first embodiment, but in the fourth embodiment, the connector **40a** is not directly folded on the rear side of the reinforcing plate **35**, but is folded on the internal surface of the rear plate **30h** and is extended along the internal surface. The membrane switch **36s** disposed within the extended membrane sheet **40** is positioned so as to be opposite to the center of the reinforcing plate **35**. A click plate **37** is interposed between this portion for the membrane switch **36s** and a projection **35b** on the reinforcing plate **35**. The click plate **37** is in contact with the projecting end face of the projection **35b** at the center of the convex side thereof.

[0129] It will be readily seen that in the fourth embodiment, as the depressing piece **32a** is depressed, the membrane switch **34s** which serves as a corresponding first step switch can be turned on with a very weak force as in the second embodiment. When the depression is continued after the first step switch **34s** has been turned on, the knob **32**, the key operation base **33** and the reinforcing plate **35** move toward the rear plate **39h** in an integral manner, whereby the projection **35b** causes an elastic deformation of the click plate **37**, the reversal of which turns the membrane switch **36s** which serves as the second step switch on.

[0130] If the depressing piece **32a** is now released from depression, the resilient restoring force of the click plate **37** urges the reinforcing plate **35** toward the surface plate **39j**, thus turning the membrane switch **36s** off and also turning the membrane switch **34s** off.

[0131] It is desirable in the third embodiment that a clearance between the peripheral surface of the depressing piece **32a** and the inner peripheral surface of the depression opening **33c** be chosen to be narrow in order to prevent the ingress of dust, and in consideration of the maneuverability when moving the finger to select a depressing piece and a good appearance. However, in order for the first step switch **34s** to be able to respond to a weak depression to be turned on, it is necessary that the depressing piece **32a** is displaced without interference with the depression opening **33c** if the depressing piece is depressed with a very weak force. In this respect, a reduction in the clearance between the peripheral surface of the depressing piece **32a** and the inner peripheral surface of the depression opening **33c** is limited in view of the dimensional accuracy and the cost required.

[0132] However, in the fourth embodiment, the spacing between the peripheral surface of the depressing piece **32a** and the inner peripheral surface of the depression opening **33c** becomes relatively large because of the necessity to make the on-load of the first step switch **34s** as small as possible, and accordingly, it is possible to turn the first step switch **34s** on reliably in response to a weak depression force without causing a problem of interference or contacting each other therebetween. In addition, the key operation surface is covered by the knobs **32** without leaving any clearance, thus precluding the likelihood of the ingress of dust and providing a good touch when selecting the depressing piece **32a** by tangibly feeling it with a finger and also providing a good appearance.

[0133] In the third mode of carrying out the invention, rather than extending the marginal portion **32d** of the elastic sheet **32c** to the internal surface of the case surface plate **39j**, it may be molded on or adhesively secured to the extension **33f** of the key operation base **33**.

Modifications

[0134] Knob

[0135] In the first embodiment, the depressing piece **32a** and the small projection **32b** of the knob **32** may be formed with a hard resin in the similar manner as the knob **32** shown in FIG. 10, while the remainder may be formed of a thermoplastic elastomer. Alternatively, as shown in FIG. 19A, a portion **32a3** of the depressing piece **32a** which projects from the surface of the elastic sheet **32c** may be formed with a hard resin while a remainder thereof **32a4** and the small projection **32b** may be formed of a thermoplastic elastomer in an integral manner with the elastic sheet **32c**.

[0136] Also in the second embodiment, the knob **32** may be entirely formed of a thermoplastic elastomer in the similar manner as the knob **32** shown in FIG. 4, or may be constructed in the manner shown in FIG. 19A.

[0137] In the third embodiment, the depressing piece **32a**, the small projection **32b**, the elastic sheet **32c** and the air gap formation **32j** of the knob **32** may be entirely formed by an integral molding from a thermoplastic elastomer, as shown in FIG. 19B. Alternatively, the small projection **32b**, the elastic sheet **32c** and the air gap formation **32j** may be formed by an integral molding from a thermoplastic elastomer while the depressing piece **32a** may be molded from a hard resin and unified with the former by adhesion or by a molding operation, as shown in FIG. 19C.

[0138] In the fourth embodiment, parts of the knob **32** may be entirely formed of a thermoplastic elastomer as shown in FIG. 19D. Alternatively, the elastic sheet **32c** and the portion **32a3** which is exposed externally may be formed of a thermoplastic elastomer while the remainder **32a4** of the depressing piece **32a** and the small projection **32b** may be integrally formed with a hard resin, as shown in FIG. 19E.

[0139] In each of the first to the fourth embodiment, the thermoplastic elastomer used in the knob **32** may be replaced by silicone rubber. It is also possible to form only the small projection **32b** with a separate resin material.

[0140] First Step Switch

[0141] In each of the first to the fourth embodiment, the membrane switch which serves as the first step switch **34s**

need not be limited to the three contact construction including a pair of fixed contacts and one movable contact as shown in FIG. 3A, but may be constructed by one fixed contact 6d and one movable contact 6f disposed opposite to each other as shown in section in FIG. 20A, for example. In the arrangement shown in FIG. 3A, lead wires for externally connecting the contacts 6a and 6b may be formed on the flexible film 6a on which the fixed contacts are disposed, but in the construction shown in FIG. 20A, it is necessary to form lead wires for external connection of both the fixed contact 6b and the movable contact 6f on the flexible films 6a and 6b, respectively.

[0142] An alternative construction as shown in FIG. 20B may be used. Specifically, a reinforcing plate 35 is formed by a printed circuit board and the fixed contacts 6d and 6e and their lead wires (not shown) may be printed on the front surface while a flexible film 46 such as a polyethylene film or the like is applied on top of the reinforcing plate 35 with spacers 45a and 45b interposed, and a movable contact 6f is printed on the flexible film 46 so as to be located opposite to the fixed contacts 6d and 6e. This flexible film 46 is depressed by the small projection 32b (not shown in FIG. 20B) of the corresponding knob 32 to become flexed, driving the movable contact 6f into contact with the fixed contacts 6d and 6e and to achieve a switch-on condition. When the depression is released, the movable contact 6f returns to its original position to resume a switch-off condition. It is to be noted that in this instance, a single fixed contact may be provided as shown in FIG. 20A and the lead wire may be printed on the flexible film 46.

[0143] As shown in FIG. 20C, a small projection 32b which comprises a conductive rubber or a metal material may be applied as an insert molding to the center of the surface of the depressing piece 32a which is opposite from a depressed surface 32a2, and the small projection 32b may have a planar projecting end face which serves as a movable contact while a pair of fixed contacts 6e and 6d and their associated lead wires may be printed on the reinforcing plate 35 as shown in FIG. 20B so that the fixed contacts 6d and 6e are located opposite to the small projection 32b acting as a movable contact, thus defining a first step switch 34s.

[0144] Alternatively, to serve as a small projection 32b which also serves as a movable contact, the small projection 32b may be constructed to have a flat projecting end face, to which a conductive painting or a conductive paste may be applied and hardened to form a movable contact 32b1 which comprises a conductive layer, as shown in FIG. 20D.

[0145] While the first step switch 34s is shown alone in FIGS. 20C and 20D, it should be understood that such first step switch 34s is provided for each depressing piece 32a. While an application to the third embodiment has been illustrated, it may also be applied as each first step switch 34s in the first, the second and the fourth embodiment.

[0146] In addition, each first step switch 34s in the first to the fourth embodiment may comprise a switch similar to a so-called touch panel which can be used as coordinate entry means, information entry means or menu selection means or the like. By way of example, as indicated by an exploded perspective view of FIG. 21A, flexible films 47a and 47b as may be formed by polyethylene films are closely spaced by a spacer 48 and fixed relative to each other, and a plurality of strip-like electrodes 49a and 49b are formed so as to be

parallel to each other on the opposing internal surfaces of the flexible films 47a and 47b. As viewed in a direction perpendicular to the flexible film 47a, the electrodes 49a and 49b are orthogonal to each other. While not shown, a small projection 32b of each depressing piece 32a is disposed in contact with the flexible film 47a at each point of intersection.

[0147] Thus if some depressing piece 32a is depressed, electrodes 49a and 49b at a corresponding point of intersection contact each other to achieve a switch-on condition, and when the depression is released, the electrodes 49a and 49b which have been in contact with each other move away from each other to resume a switch-off condition. It is only necessary that the electrodes 49a and 49b intersect with each other as viewed in a direction perpendicular to the flexible film 47a or the key operation surface, and the plurality of electrodes 49a and 49b need not be parallel to each other, nor it is required that they are straight lines. Since this is not a touch panel which is commonly used, the use of a transparent film or transparent electrode is not required, and because they are not exposed externally, the thickness of each flexible film 47a, 47b can be reduced as desired. It is pointed out that a touch panel of the kind described is disclosed in Japanese Laid-Open Patent Application No. 61,603/93 (issued Mar. 12, 1993).

[0148] A touch panel which uses resistive films is also known and can be used as the first step switch 34s. By way of example, as illustrated in FIG. 21B in the form of an exploded perspective view, flexible films 47a and 47b are closely spaced by a spacer 48 and disposed opposite to each other. Resistive films 51a and 51b are formed on the opposing surfaces of the flexible films 47a and 47b. Electrodes 52a and 52b are formed at one end of one of the resistive films, 51b, while electrodes 52c and 52d are formed at remaining ends. While not shown, small projections 32b of a plurality of depressing pieces 32a are disposed on the closely spaced resistive films 51a and 51b in contact with the flexible film 47a. The resistive films 51a may comprise a conductive film having a small resistance.

[0149] When one of the depressing pieces 32a is depressed, a corresponding location of the resistive film 51a comes into contact with the resistive film 51b. A voltage which is developed across the resistive film 51a when a voltage is applied across the electrode 52a and 52b under this condition and a voltage which is developed across the resistive film 51a when a voltage is applied across the electrodes 52c and 52d are measured, and on the basis of these voltage values, a detection is made of which one of the depressing pieces 32a has been depressed or whether the first step switch 34s which corresponds to that depressing piece 32a has been operated and turned on. A touch panel of the kind described is disclosed in Japanese Laid-Open Patent Application No. 189,150/93 (issued Jul. 30, 1993), for example.

[0150] Second Step Switch

[0151] Each of the second step switches 36 shown in the first to the fourth embodiment may be constructed as shown in FIG. 22A. A pair of fixed contacts 53a and 53b and their external connection lead wires (not shown) are formed by printed circuit technology on the surface of the reinforcing plate 35 which is located opposite to the rear plate 39h. A click plate 37 is mounted on the reinforcing plate 35 in a

manner to oppose the fixed contacts **53a** and **53b** with a ring-shaped spacer **54** interposed therebetween. The click plate **37** is convex toward the rear plate **39h**, and a projection **39i** is integrally formed on the rear plate **39h** in contact with the center of the click plate **37**. When the reinforcing plate **35** moves toward the rear plate **39h** in response to the depression of the depressing piece **32a**, the click plate **37** undergoes an elastic deformation to reverse, whereupon the click plate **37** moves into contact with the both fixed contacts **53a** and **53b** to achieve an electrical conduction therebetween, thus turning the second step switch **36**s on. When the depression is removed, the elastic deformation of the click plate **37** is removed to resume a switch-off condition.

[0152] The second step switch **36** may also be constructed as shown in FIG. 22B. This represents what is referred to as a rubber contact switch which provides a clicking sensation. This switch is dome-shaped and includes a top **55a**, the top surface of which is disposed in abutment against the rear surface of the reinforcing plate **35** at a central position while the end of the top **55a** which is located opposite from the top surface is connected around its periphery with a ring-shaped base **55c** through a skirt **55b**. A projection **55d** is formed on the inner surface of the top **55a**, and a movable contact **53c** is formed on the projecting end face of the projection **55d**. The base **55c** is disposed in abutment against the central portion of the rear plate **39h**, and fixed contacts **53a** and **53b** are formed on the rear plate **39h** inside the base **55c** so as to be opposite to the movable contact **53c**. The top **55a**, the skirt **55b**, the base **55c** and the projection **55d** are formed as an integral molding of rubber material. The fixed contacts **53a** and **53b** and their external connection lead wires (not shown) are printed on the rear plate **39h**. The top surface of the top **55a** is secured to the reinforcing plate **35** or the base **55c** is secured to the rear plate **39h** as by adhesion.

[0153] As the reinforcing plate **35** moves toward the rear plate **39h** in response to the depression of the depressing piece **32a**, the skirt **55b** undergoes an elastic deformation to reverse, whereby the movable contact **53c** move into contact with the fixed contacts **53a** and **53b**, thus turning the switch on. The reversal of the skirt **55b** provides a clicking sensation. When the depression is released, original configurations are restored due to the resilient restoring force of the skirt **55b**, thus resuming a switch-off condition.

[0154] It should be noted that each second step switch **36** shown in the first to the fourth embodiment may also be used in other embodiments. For example, the second step switch **36** shown in the first embodiment may be used as the second step switch **36** in one of the second to the fourth embodiment.

[0155] The second step switch **36** which has self-restoring force and which provides a clicking sensation has been illustrated. However, while the presence of the clicking sensation is desired in the prior art in due of a reliable operation during a normal key entry, it is not essential. Where a second step switch **36** which does not provide a clicking sensation is used, it is desirable that a switch be used which requires a certain stroke before a switch-on condition is reached or a switch which provides a stroking sensation. On the other hand, if the second step switch **36** which provides the clicking sensation is used, a switch with a reduced length of stroking can be used, allowing a thin switch unit to be constructed.

[0156] With reference to the second step switch **36** used in the first to the fourth embodiment, if a slight inclination of the knob **32**, the key operation base **33** and the reinforcing plate **35** in response to the depression can be allowed, or if an arrangement is made which allows a rotation about a point of contact between the surface plate **39j** and the flange **33e** in FIG. 11 such that a point located on the other end is allowed to move toward the rear plate **39h**, the pusher **35b** may be omitted if the actuator **36a** can be directly driven by the reinforcing plate **35** to turn the switch on without any influence of such inclination upon a corner or shoulder of the switch case **36b** which is disposed on the opposite side from the rear plate **39h**. Similarly, other corresponding pushers can be omitted.

Fourth Mode of Carrying out the Invention

[0157] Another mode of carrying out the invention according to a second aspect thereof is directed toward overcoming the problems of a conventional depression responsive switch unit which have been described with reference to FIGS. 23 to 25. This will be described as the fourth mode of carrying out the invention with reference to FIG. 26. A case **71** is constructed as a rigid body, or constructed as a molding of a hard resin such as ABS resin, polycarbonate or the like, for example, and a knob **72** which is formed of a similar hard resin is disposed so as to block an opening **71b** formed in the surface plate **71a** of the case **71**. The knob **72** is retained by the case **71** by using a thin-walled resilient member **76** such that it is readily deformable in the direction of a normal depression, but is hardly deformable in a direction perpendicular to the direction of a normal depression, or readily displaceable in a direction perpendicular to the rear plate **71**, but is hardly displaceable in a direction parallel to the rear plate **71e**.

[0158] The resilient member **76** is formed of a thin-walled metal, fiber, paper, hard resin, elastomer, silicone rubber or the like which is hard to stretch, but is pliable to bend. The resilient member **76** is configured to be symmetrical with respect to the axis of the knob **72**. A switch **73** having a self-restoring function is mounted centrally on the internal surface of the rear plate **71**. When the knob **72** is depressed, the knob **72** drives the switch **73**, turning it on. At this time, if the depression is applied to one point around the edge of the knob **72**, the retaining function of the resilient member **76** causes the knob **72** to move in a direction perpendicular to the rear plate **71 e**. Accordingly, the switch **73** is always turned on with an even depressing force, allowing a long useful life of a return spring and providing a substantially constant tactile impression and stroking length.

Fifth Embodiment

[0159] FIGS. 26 and 27 show an embodiment according to the fourth mode of carrying the invention. The case **71** is in the form of a square box, and the opening **71b** in the surface plate **71a** is circular and is substantially centered about the axis of the case **71**. Screws **74** are inserted into openings **71f** in the rear plate **71e**, and are threadably engaged with bores **71g** formed in the end face of the sidewall **71i** of the case **71** at the corners thereof, thus securing the rear plate **71e** to the sidewall **71i**.

[0160] The knob **72** has a circular top plate **72d** which is positioned so as to substantially block the opening **71b**. The

top plate 72d is centrally formed with a projection 72c on its internal surface. For connection with the resilient member 76, a tubular portion 72e which is centered about the projection 72c is integrally formed with the internal surface of the top plate 72d. The tubular portion 72e has a length which is slightly less than the projection 72c. In addition, the top plate 72d is integrally formed with a flange 72f which has a step in a direction in which the projection 72c projects.

[0161] A member connector 71j is formed on the internal surface of the case sidewall 71i, and has a connection surface 71j1 located toward the rear plate 71e which is substantially coplanar with the end face of the tubular portion 72e when the flange 72f abuts against the internal surface of the surface plate 71a. As viewed in FIG. 26, the member connector 71j is cylindrical about the axis of the opening 71b, and is unified with the internal surface of the sidewall 71i by contact therewith at four locations around the outer peripheral surface.

[0162] The resilient member 76 has a configuration which is symmetrical with respect to the axis of the knob 72 and includes at least three linear portions which extend radially at an equi-angular interval from the tubular portion 72e to the member connector 71i to connect the case 71 and the knob 72 together. Specifically, it comprises a ring-shaped movable connector 76a, a ring-shaped case connector 76b having a greater diameter, and a body 76c including linear portions which connect between the both connectors 76a and 76b. In the present example, the body 76c includes at least three linear portions, although sixth linear portions are shown in FIG. 7, in the form of ribbons which are disposed at an equi-angular interval. These ribbons of the body 76c are slightly curved to be convex toward the rear plate 71e. The connectors 76a and 76b and the body 76c are integrally formed by a resilient material such as thin metal sheet or hard resin.

[0163] The knob connector 76a is secured to the end face of the tubular portion 72e of the knob 72 as by adhesion while the case connector 76b is secured to the connection surface 71j1 of the member connector of the case 71 as by adhesion. A tact switch is used as the switch 73. The tact switch 73 is secured to the rear plate 71e and has an actuator 73a, the projecting end face of which abuts against the end face of the projection 72c of the knob, and a reversal spring within the tact switch 73 causes the flange 72f of the knob 72 to abut against the internal surface of the surface plate 71a.

[0164] With this construction, if the depression is applied to a point around the periphery of the knob 72, as indicated in FIG. 28 by way of example, a component of the depressing force acting upon the knob 72 which is parallel to the rear plate 71e is applied to the body 76c of the resilient member 76 in its lengthwise direction, whereby the body 76c is hardly deformable, thus suppressing the parallel component. However, a component of the depressing force which acts perpendicular to the rear plate 71e acts upon the free ends of the ribbon-shaped body 76c which are secured to the case 71e at their other end, allowing a deformation to occur readily even with a weak force. Thus, the knob 72 is displaced toward the rear plate 71e against the reaction from an internal spring within the tact switch 73 and without producing an inclination, whereby the actuator 73a is driven into the switch case 73b, causing a reversal of the internal spring to turn the tact switch 73 on.

[0165] Wherever the knob 72 is depressed, the projection 72c urges the actuator 73a in a direction perpendicular to the rear plate 71e, and accordingly, the tact switch 73 operates reliably even with a weak force with a good clicking sensation and with an even stroking length. A stress which is applied to the reversal spring within the tact switch 73 is maintained relatively low, increasing the useful life of the reversal spring. It should be noted that in an arrangement which lacks the resilient member 76, it will be seen that when a point around the periphery of the knob is depressed, there acts upon the knob 72 a rotating force centered about a point of contact 78 between a region of the flange 72f which is located on the opposite side of the projection 72c from the depressed point and the surface plate 71a, as shown in FIG. 29, whereby a force in a direction parallel to the rear plate 71e is applied to the actuator 73a, giving rise to a problem which is similar to that experienced in the prior art as described above with reference to FIG. 23. However, in the fifth embodiment, a component of the depressing force which is parallel to the rear plate 71e is suppressed by the resilient member 76, and accordingly, the knob 72 is readily displaced in a direction toward the rear plate 71e while maintaining its parallel relationship with respect to the rear plate 71e.

[0166] As will be apparent from the description of the action of the fifth embodiment, the body 76c should preferably be as parallel to the rear plate 71e as possible from the standpoint of making the body 76c less susceptible to a force acting lengthwise thereof and in a direction parallel to the rear plate 71e to curve (or to deform). However, it is preferred that the knob connector 76a is readily displaceable with a weak force in a direction perpendicular to the rear plate 71e. Consequently, it is desirable to have a curvature of the body 76c relative to the rear plate 71e which allows the switch 73 to be reliably turned on and which is gentle enough to avoid tensioning the body 76c. In addition, from the standpoint of making the knob 72 to be readily displaceable in a direction toward the rear plate 71e, it is preferred that a connection be made between a portion of the knob 72 which is located toward the center and a portion of the case 71 which is located toward the sidewall in order to increase the length of the linear body 76c.

Sixth Embodiment

[0167] FIG. 30 shows a sixth embodiment as another example of the fourth mode of carrying out the invention. In this example, a ring-shaped resilient member 76 which is U-shaped in section has its outer periphery and inner periphery secured to the periphery of the opening 71b on the internal surface of the surface plate 71a of the case 71 and to the periphery of the knob 72 on its internal surface, respectively, as by adhesion. In this instance, the resilient member 76 is constructed such that the body 76c extending between connectors 76b and 76a which are connected to the case 71 and the knob 72, respectively, be formed over the entire perimeter, and the resilient member 76 may be formed of a variety of materials as mentioned previously. However, in particular, a thermoplastic elastomer or a silicone rubber is suitable at this end.

[0168] With this construction, when a central portion of the knob 72 is depressed, only a force which is directed perpendicular to the rear plate 71e is evenly applied to every portion of the knob connector 76a of the ring-shaped resil-

ient member 76, so that the body 76c is deformed readily and evenly, allowing the knob 72 to be displaced toward the rear plate 71e while maintaining its parallel relationship with respect to the rear plate 71e.

[0169] If the depression is applied to the knob 72 at a point toward the periphery thereof, a force which causes the knob 72 to be inclined with respect to the rear plate 71e or which causes the knob 72 to move in a direction parallel to the rear plate 71e will act. However, when a peripheral surface portion 76c1 disposed toward the knob connector 76a and which is formed as one limb of the U-shaped section and a peripheral surface portion 76c2 which is disposed toward the case and which defines the other limb are integrally connected together through an intermediate portion of U-shape, the body 76c of the resilient member 76 which is U-shaped in section acts to change the portions 76c1 and 76c2 relative to each other in a plane which is parallel to the rear surface 71e. Accordingly, it would appear that at one of left and right ends as viewed in FIG. 30, the peripheral surface portions 76c1 and 76c2 move toward each other while they move away from each other at the other end, and therefore, if this aspect is considered alone, it would appear that the knob 72 will be relatively readily displaced to the right, for example. However, when the viewpoint is shifted to the center and considering opposite ends of a line which extends in a direction perpendicular to the plane of the drawing, there acts a force which causes the peripheral surface portions 76c1 and 76c2 to be offset to the left and to the right, respectively. Because such action must be considered, it will be seen that a greater force will be required to offset the peripheral surface portion 76c1 relative to the peripheral surface portion 76c2. As a consequence, if the knob 72 is edgewise depressed, the action of the resilient member 76 is effective to cause the knob 72 to move relative to the rear plate 71e while maintaining its parallel relationship therewith.

[0170] As discussed above, a functioning and effect similar to that obtained in the fifth embodiment is available in the sixth embodiment. As will be understood from the described functioning and effect, the ring-shaped resilient member 76 which is U-shaped in section is more effective when the both limbs of the U-shape or the both peripheral surface portions 76c1 and 76c2 are located closely relative to each other, and therefore should be connected to locations which are as close to the casing 71 and the knob 72, respectively, as possible.

[0171] The resilient member 76 blocks a space between the surface plate 71a and the knob 72, thus providing a dust-proof effect. As indicated in broken lines in FIG. 30, when the resilient member 76 including the linear body 76c shown in FIG. 26 is also used in combination, the maneuverability against an edgewise depression is improved.

[0172] Modification

[0173] A resilient member 76 may be constructed as shown in FIGS. 31A and 31B, for example, where a body 76c disposed between a knob connector 76a and a case connector 76b is corrugated in the form of concentric circles with the both connectors 76a, 76b, thus connecting the both connectors 76a and 76b over the full perimeter. The material to form such an example should preferably be paper or fiber.

[0174] A further example is shown in FIG. 31C where a resilient member 76 comprises a single flat sheet, which is

circular in this example. A circular opening 76d is formed at the center of the sheet, and the periphery of the circular opening 76d defines a knob connector 76a, which may be adhesively secured to the end face of the tubular portion 72e shown in FIG. 26, for example. Small openings 76e are formed in the outer periphery of the resilient member 76 at least three locations or at four locations as shown in FIG. 36C. The periphery of the small opening 76e defines the case connector 76b to be secured to the case 71. This securing operation may take place in the similar manner as securing the peripheral edge 32f shown in FIG. 8, for example. A construction material chosen in this instance should preferably be a thermoplastic elastomer or a silicone rubber. This makes the knob 72 to be readily displaceable in a direction toward the rear plate 7e, but hardly displaceable in a direction parallel to the rear plate 71e.

[0175] The switch 73 is not limited to the tact switch. What is required is that the switch is turned on when the knob 72 is depressed and that when the depression is released, the resilient restoring force of the spring automatically returns the knob 72 to its original condition. The presence of the clicking sensation is not required. The second step switch 36 shown in FIG. 4 or switches shown in FIGS. 22A and 22B may be used.

Fifth Mode of Carrying out the Invention

[0176] The fifth mode of carrying out the invention is applied to a depression responsive two-step switch unit where the knob 72 which operates on the second-step switch 73 is retained by a resilient member 76.

[0177] The arrangement which is the same as the first embodiment mentioned above, for example, may be cited as an embodiment for this mode. Specifically, referring to FIGS. 4 to 7, the second step switch 36 corresponds to the switch 73, and the associated knob 72 comprises the knob 32, the key operation base 33, the first step switch 34s and the reinforcing plate 35 which are unified. The marginal portion 32f is secured to the case 39 at a plurality of points while the remainder remains free, and this corresponds to a modification of the resilient member 76 shown in FIG. 31C. Similarly, the second embodiment mentioned previously with reference to FIG. 10 is also equivalent to an embodiment of the fifth mode of carrying out the invention. The knob 72 remains similar to the first embodiment, the second step switch 73 corresponds to the second step switch 36 shown in FIG. 10, and the resilient member 76 comprises the marginal portion 32f which is U-shaped in section, this corresponding to one shown in FIG. 30.

[0178] A movable portion including each first step switch 34s which is used in the first to the third mode of carrying out the invention or the portion which drives the second step switch 36 is chosen as a knob 72 in another embodiment of the fifth mode of carrying out the invention which uses the resilient member 76 used in the fourth mode of carrying out the invention. Such an embodiment is illustrated by a combination of the first and the fifth embodiment, which is shown in section in FIG. 32 even though a duplicated description is omitted. In FIG. 32, a member connector 71j is formed on the internal surface of the sidewall 71i at a location toward the rear plate 71e, and has a connecting surface 71j2 toward the cover (surface plate) 31, to which the case connector 76b of the resilient member 76 is secured.

Specifically, when combining one of the first to the third mode with the fourth mode of carrying out the invention, the key operation base **33** and the surface plate **39j** and/or the reinforcing plate **35** or the projection **35b** thereon and the case sidewalls **39a**, **39b** are connected together by the resilient member **76**.

[0179] A first step switch used in the embodiment for the fifth mode of carrying out the invention is not limited to those mentioned above in connection with the first to the third mode of carrying out the invention as well as modifications thereof, but may be a membrane switch which is covered with the surface sheet shown in FIGS. 1 to 3, for example, or may be a touch panel shown in FIG. 21A or 21B which is arranged to be directly depressed from the exterior.

[0180] A schematic illustration of what is mentioned above is illustrated in FIG. 33 by way of example. In this example, a knob **72** is retained by a case **71** through a resilient member **76₁** having a linear body which is used in the fifth embodiment and a resilient member **76₂** having a ring-shaped body which is U-shaped in section and which is used in the sixth embodiment. In other words, a portion of the knob **72** which is located close to the projecting end of the projection **72c** and another portion thereof which is located close to the internal surface of the top plate **72d** are retained by the case **71** through different kinds of resilient members **76₁** and **76₂**. Specifically, the knob **72** is retained by the case **71** through two resilient members **76₁** and **76₂** which are spaced apart in a direction perpendicular to the rear plate **71e**. A first step switch **79** such as a membrane switch or a touch panel is disposed on the top plate **72d** of the knob **72**. While not shown, whatever the construction of the first step switch **79**, a band-shaped flexible cable (FBC) including external connection lead wires for respective switches in the first step switch assembly **79** is taken out from the interior of the case **71**, as illustrated by FBC8 in FIGS. 1 to 3, for example.

[0181] In the two-step switch unit according to the fifth mode of carrying out the invention, the second step switch **73** may comprise a variety of switches without being limited to the tact switch, in the similar manner as mentioned above.

What is claimed is:

1. A depression responsive switch unit in which a switch is turned on in response to a depression operation; comprising

- a case including a surface plate in which an opening is formed;
- a reinforcing plate disposed opposite to a rear plate of the case and disposed within the case so as to be reciprocal with respect to the rear plate;
- a second step switch interposed between the reinforcing plate and the rear plate and adapted to be operated on by a movement of the reinforcing plate toward the rear plate;
- a plurality of first step switches disposed on the reinforcing plate on the side located toward the surface plate;
- a key operation base disposed on the case in a manner to block the opening in the surface plate and formed with depression openings each located corresponding to each first step switch;

and a knob disposed on the key operation base on the opposite side from the reinforcing plate;

the knob including an elastic sheet which is formed of a thermoplastic elastomer or a silicone rubber and having a marginal portion which is retained by the case, depressing pieces formed on the elastic sheet in a manner corresponding to each first step switch and having a depressed surface on the front side of the elastic sheet and disposed in each depression opening, and a small projection projecting from each depressing piece in the opposite direction from the depressed surface to be located close to or in contact with the first step switch.

2. A depression responsive switch unit according to claim 1, in which the elastic sheet, the depressing pieces and the small projections are integrally formed with a thermoplastic elastomer or silicone rubber.

3. A depression responsive switch unit according to claim 1 in which the elastic sheet is formed with an opening in a manner corresponding to each depressing piece, the depressing piece being passed through a corresponding one of the openings, a depressing piece having a flange which is disposed in abutment against and secured to the elastic sheet, each depressing piece, its flange and corresponding small projection being integrally formed with a hard resin.

4. A depression responsive switch unit according to claim 1 in which each depressing piece comprises an external portion which is exposed externally of the elastic sheet and a remainder, the external portion being formed by a hard resin while the remainder of the depressing piece being integrally formed of a thermoplastic elastomer or silicone rubber together with the elastic sheet and the small projection.

5. A depression responsive switch unit according to claim 1 in which the marginal portion of the elastic sheet is held sandwiched by the case at only a plurality of locations to be secured.

6. A depression responsive switch unit according to claim 1 in which the marginal portion of the elastic sheet is formed with a ring which is U-shaped in section around the full perimeter of the knob at a location inside thereof which is retained by the case.

7. A depression responsive switch unit in which a switch is turned on in response to a depression operation comprising

- a case including a surface plate in which an opening is formed;
- a reinforcing plate disposed opposite to a rear plate of the case and disposed within the case so as to be reciprocal relative to the rear plate;
- a second step switch interposed between the reinforcing plate and the rear plate and operated on by a movement of the reinforcing plate toward the rear plate;
- a plurality of first step switches disposed on the reinforcing plate on the side located toward the surface plate;
- a key operation base disposed on the case so as to block the opening in the surface plate and formed with depression openings corresponding to the location of each first step switch;
- and a knob disposed between the reinforcing plate and the key operation base;

the knob including an elastic sheet which is formed of a thermoplastic elastomer or a silicone rubber and having a marginal portion which is held sandwiched between the key operation base and the reinforcing plate to be secured, depressing pieces formed on the elastic sheet so as to correspond to each first step switch, each depressing piece being disposed in a depression opening formed in the key operation base, and a small projection projecting from elastic sheet for each depressing piece to be located close to or in contact with the first step switch.

8. A depression responsive switch unit according to claim 7 in which the elastic sheet is formed with a plurality of air gap formations which project toward the reinforcing plate and which are located on the opposite sides of each small projection and spaced therefrom by an equal distance, the air gap formations being in contact with the reinforcing plate.

9. A depression responsive switch unit according to claim 7 in which the elastic sheet is formed with a small opening in a manner corresponding to each depressing piece, the depressing piece having a depressed surface and a mounting surface which is located on the opposite side from the depressed surface and which is disposed in abutment against and secured to the elastic sheet, the small projection being integrally formed centrally in the mounting surface, the small projection extending through the small opening to project toward the reinforcing plate from the elastic sheet, each depressing piece and small projection being integrally formed from a hard resin.

10. A depression responsive switch unit according to claim 7, in which the elastic sheet, the depressing piece and the small projection are integrally formed by a thermoplastic elastomer or a silicone rubber.

11. A depression responsive switch unit according to claim 7, in which the elastic sheet and the small projection are integrally formed of a thermoplastic elastomer or silicone rubber while the depressing piece is formed of a hard resin and is secured to the elastic sheet as is the corresponding small projection.

12. A depression responsive switch unit in which a switch is turned on in response to a depression operation, comprising

a case including a surface plate in which an opening is formed;

a reinforcing plate disposed opposite to a rear plate of the case and disposed within the case so as to be reciprocable with respect to the rear plate;

a second step switch interposed between the reinforcing plate and the rear plate and operated on by a movement of the reinforcing plate toward the rear plate;

a plurality of first step switches disposed on the reinforcing plate on the side located toward the surface plate;

a key operation base disposed on the case in a manner to block the opening in the surface plate and having depression openings formed therein in a manner corresponding to the location of each first step switch;

and a knob disposed on the key operation base on the opposite side from the reinforcing plate;

the knob including an elastic sheet which is formed of a thermoplastic elastomer or silicone rubber and having a marginal portion which is secured by being held

sandwiched between the key operation base and the reinforcing plate, depressing pieces formed on the elastic sheet in a manner corresponding to each first step switch and each having a depressed surface on the front side of the elastic sheet and each disposed in the depression opening, and a small projection projecting from each depressing piece in the opposite direction from the depressed surface to be located close to or in contact with the first step switch.

13. A depression responsive switch unit according to claim 12 in which the elastic sheet is formed with openings to receive each depressing piece, each depressing piece having a flange which is disposed in abutment against and secured to the elastic sheet, each depressing piece, its flange and associated small projection being integrally formed from a hard resin.

14. A depression responsive switch unit according to claim 12 in which the elastic sheet, the depressing piece and the small projection are integrally formed by a thermoplastic elastomer or a silicone rubber.

15. A depression responsive switch unit according to claim 12 in which each depressing piece has an external portion which is exposed externally of the elastic sheet and a remainder, the external portion being formed from a hard resin while the remainder of the depression piece, the elastic sheet and the small projection being integrally formed of a thermoplastic elastomer or silicone rubber.

16. A depression responsive switch unit in which a switch is turned on in response to the depression of a knob, comprising

a case including a surface plate in which an opening is formed;

a knob disposed in the case so as to block the opening;

a resilient member connecting the knob to the case in a manner such that the knob is readily displaceable in the direction of a depression which is perpendicular to the surface plate and is hardly displaceable in a direction perpendicular to the direction of depression;

and a switch disposed within the case on the case rear plate and operated on by a displacement of the knob as it is depressed.

17. A depression responsive switch unit according to claim 16 in which the resilient member comprises at least three linear members which are connected to the central portion of the knob and a sidewall of the case at an equi-angular interval.

18. A depression responsive switch unit according to claim 16 in which the resilient member is a ring which is U-shaped in section and connected to the marginal portion of the knob and to the opening around the full perimeter.

19. A depression responsive switch unit according to claim 16 in which the resilient member comprises a first and a second resilient member which connect between the knob and the case at locations which are spaced apart in a direction perpendicular to the rear plate.

20. A depression responsive switch unit according to claim 16 in which a first step switch is formed on the knob which can be turned on by a weak depression which cannot turn the switch on.

21. A depression responsive switch unit according to claim 20 in which the knob comprises a reinforcing plate, a plurality of first step switches disposed on the reinforcing

plate, a key operation base secured to the reinforcing plate and having openings each corresponding to each first step switch, a depressing piece which is at least partly disposed within each opening, an elastic sheet carrying the depressing pieces and formed of a thermoplastic elastomer or silicone

rubber, and a small projection projecting from each depressing piece in a direction opposite from the depressed surface to be located close to or in contact with the first step switch.

* * * * *