



US 20160136339A1

(19) **United States**

(12) **Patent Application Publication**
BEGIN et al.

(10) **Pub. No.: US 2016/0136339 A1**

(43) **Pub. Date: May 19, 2016**

(54) **SYSTEMS AND METHODS FOR APPLYING REDUCED PRESSURE THERAPY**

(71) Applicant: **SMITH & NEPHEW INC.**, Memphis, TN (US)

(72) Inventors: **Miles BEGIN**, New York, NY (US); **Brian P. BJELOVUK**, Westerville, OH (US); **Ethan R. BLISS**, New York, NY (US); **Giacomo F. CIMINELLO**, Cincinnati, OH (US); **Kealoha DEUTSCH**, Saint Petersburg, FL (US); **William W. GREGORY**, Saint Petersburg, FL (US); **Kory A. GUNNERSON**, Cincinnati, OH (US); **William Joseph JAECKLEIN**, Saint Petersburg, FL (US); **Kathryn Ann LEIGH**, Saint Petersburg, FL (US); **Ke LI**, East Islip, NY (US); **Chelsea F. MCLEMORE**, Long Island, NY (US); **Benjamin S. MILLER**, Brooklyn, NY (US); **Andrew P. MUSER**, Saint Petersburg, FL (US); **Jerad C. RAINES**, Newport, KY (US); **Billy J. RATLIFF**, Commerce Township, MI (US); **Michael T. ROLLER**, Covington, KY (US); **Robert H. ROTH**, Cincinnati, OH (US); **Vera N. SOPER**, Cincinnati, OH (US); **Karl W. VANDERBEEK**, Cincinnati, OH (US); **Lauren W. WOODRICK**, Covington, KY (US); **Micah C. ZENDER**, Camp Dennison, OH (US)

(21) Appl. No.: **14/775,339**

(22) PCT Filed: **Mar. 13, 2014**

(86) PCT No.: **PCT/US14/26692**

§ 371 (c)(1),

(2) Date: **Sep. 11, 2015**

Related U.S. Application Data

(60) Provisional application No. 61/785,384, filed on Mar. 14, 2013, provisional application No. 61/860,809, filed on Jul. 31, 2013.

Publication Classification

(51) **Int. Cl.**
A61M 1/00 (2006.01)

(52) **U.S. Cl.**
CPC **A61M 1/0086** (2014.02); **A61M 1/0023** (2013.01); **A61M 2209/082** (2013.01)

(57) **ABSTRACT**

Embodiments of reduced pressure systems and methods for operating the systems are disclosed. In some embodiments, a system can include a source of negative pressure and a controller configured to present GUI screens for controlling and monitoring operation of the system. The controller can be configured to receive, via the GUI, an adjustment of a negative pressure therapy parameter and adjust (or cause adjustment) of the operation of the negative pressure source based on received adjustment. The controller can be further configured to record historical data parameters associated with negative pressure therapy parameters. The controller can also be configured to transmit (or cause transmission) over a communication channel at least some of recorded historical data. The system can be configured to provide external connectivity for accomplishing various activities, such as location tracking, compliance monitoring, tracking of operational data, remote selection and adjustment of therapy settings, etc.

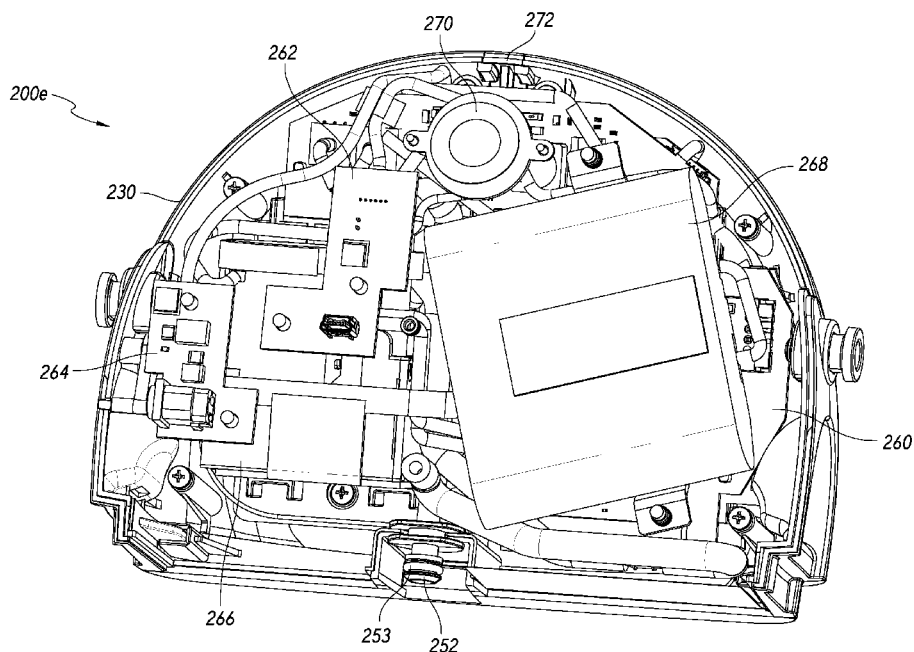

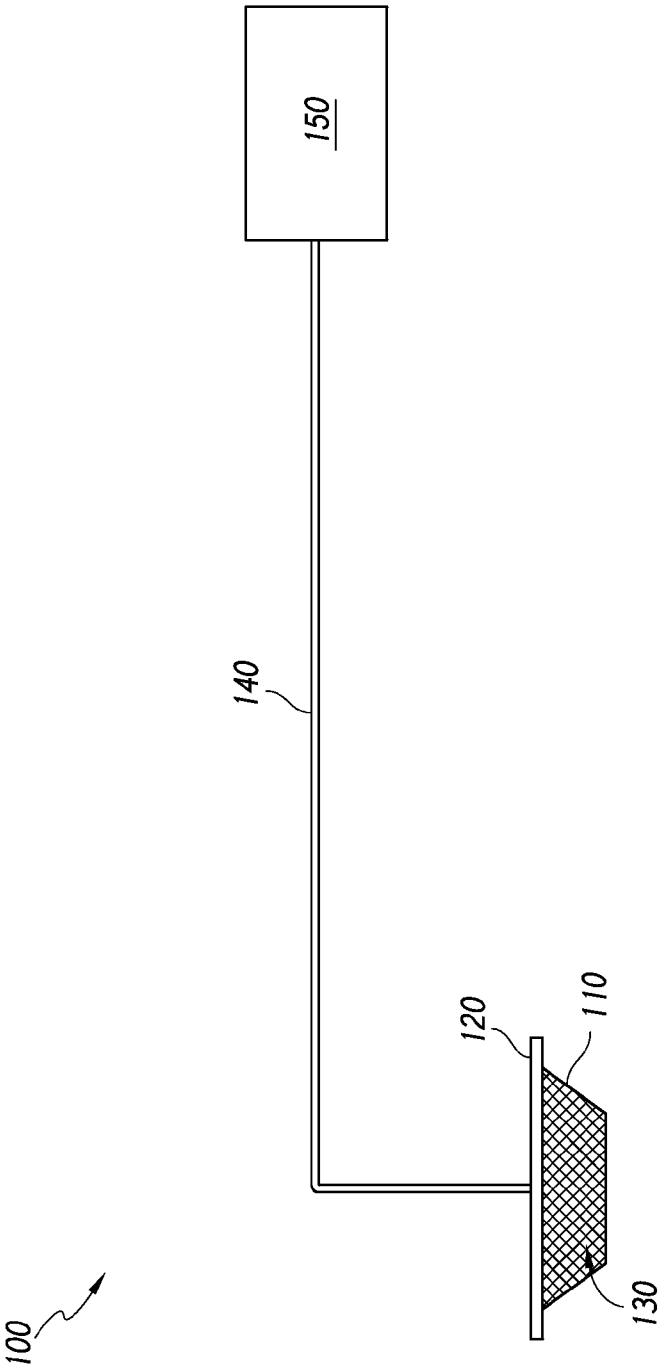

FIG. 1

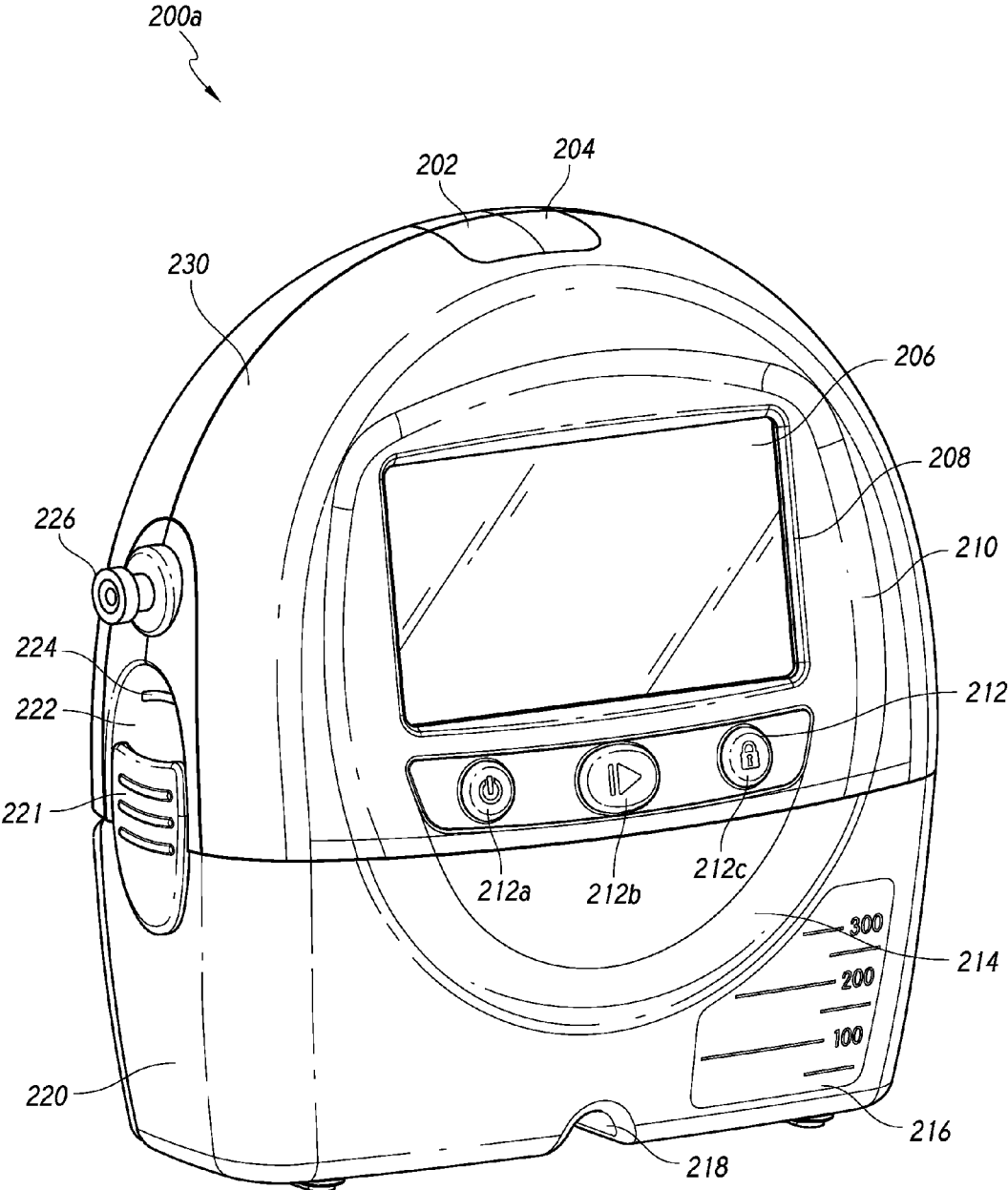

FIG. 2A

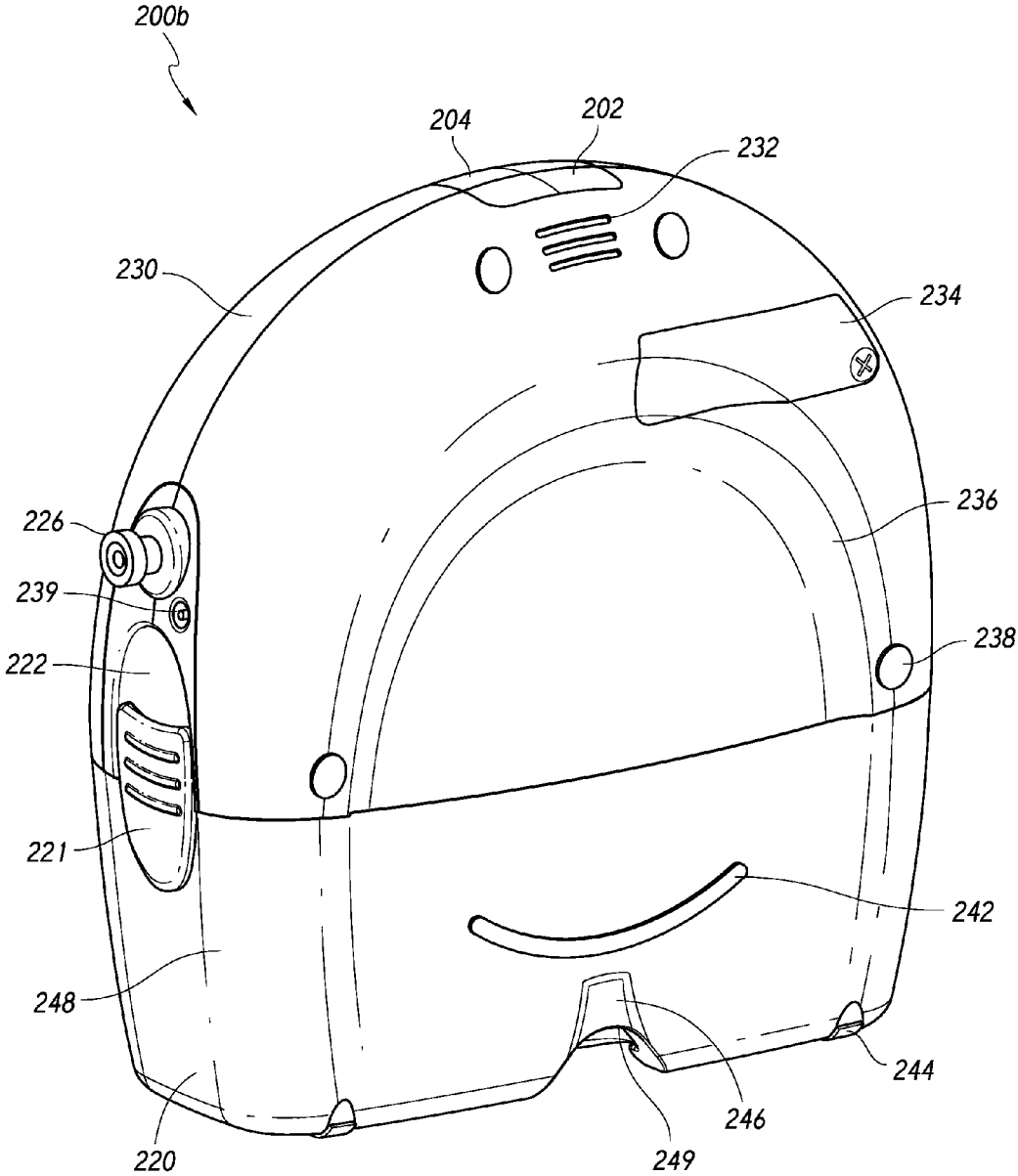

FIG. 2B

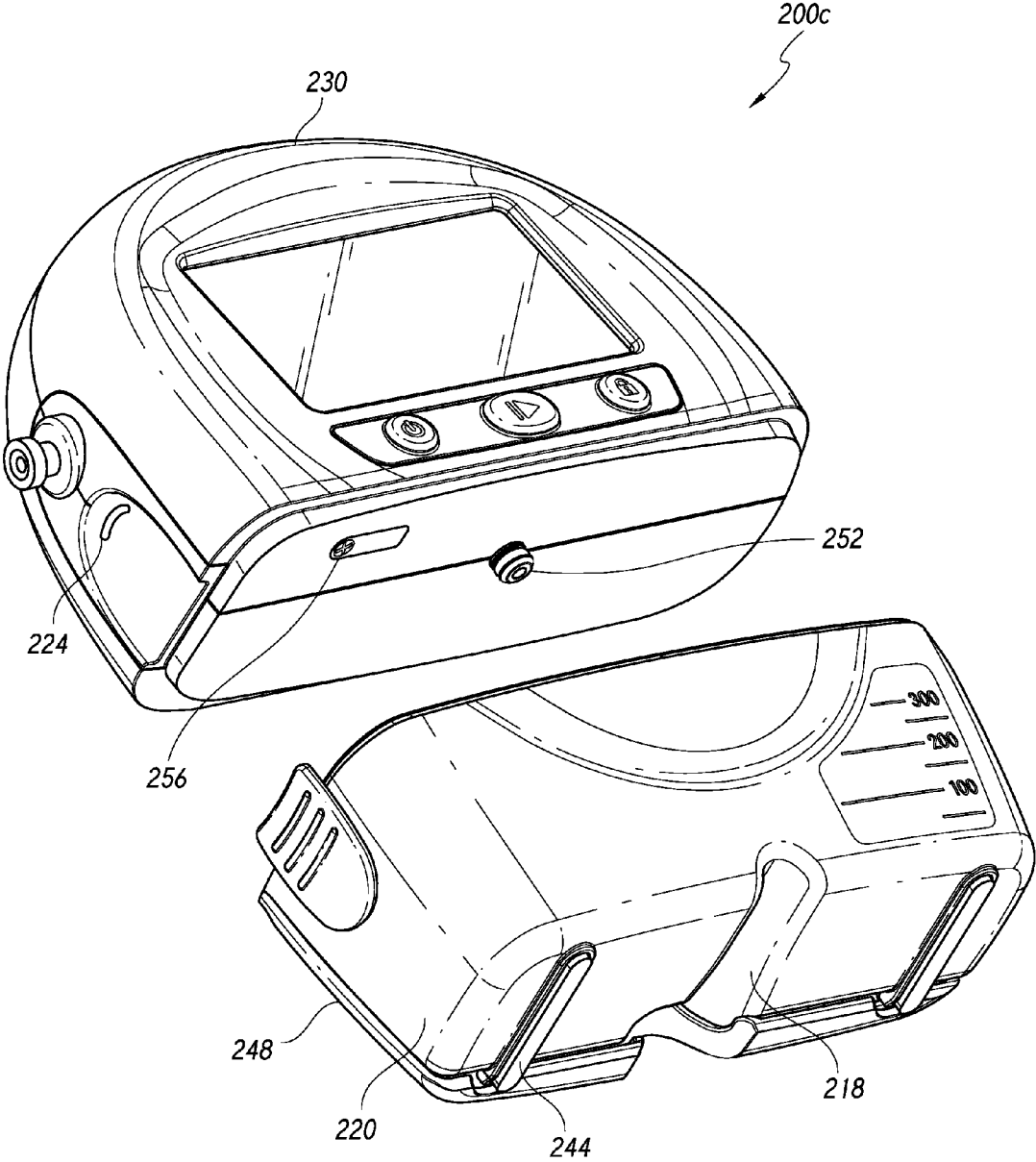

FIG. 2C

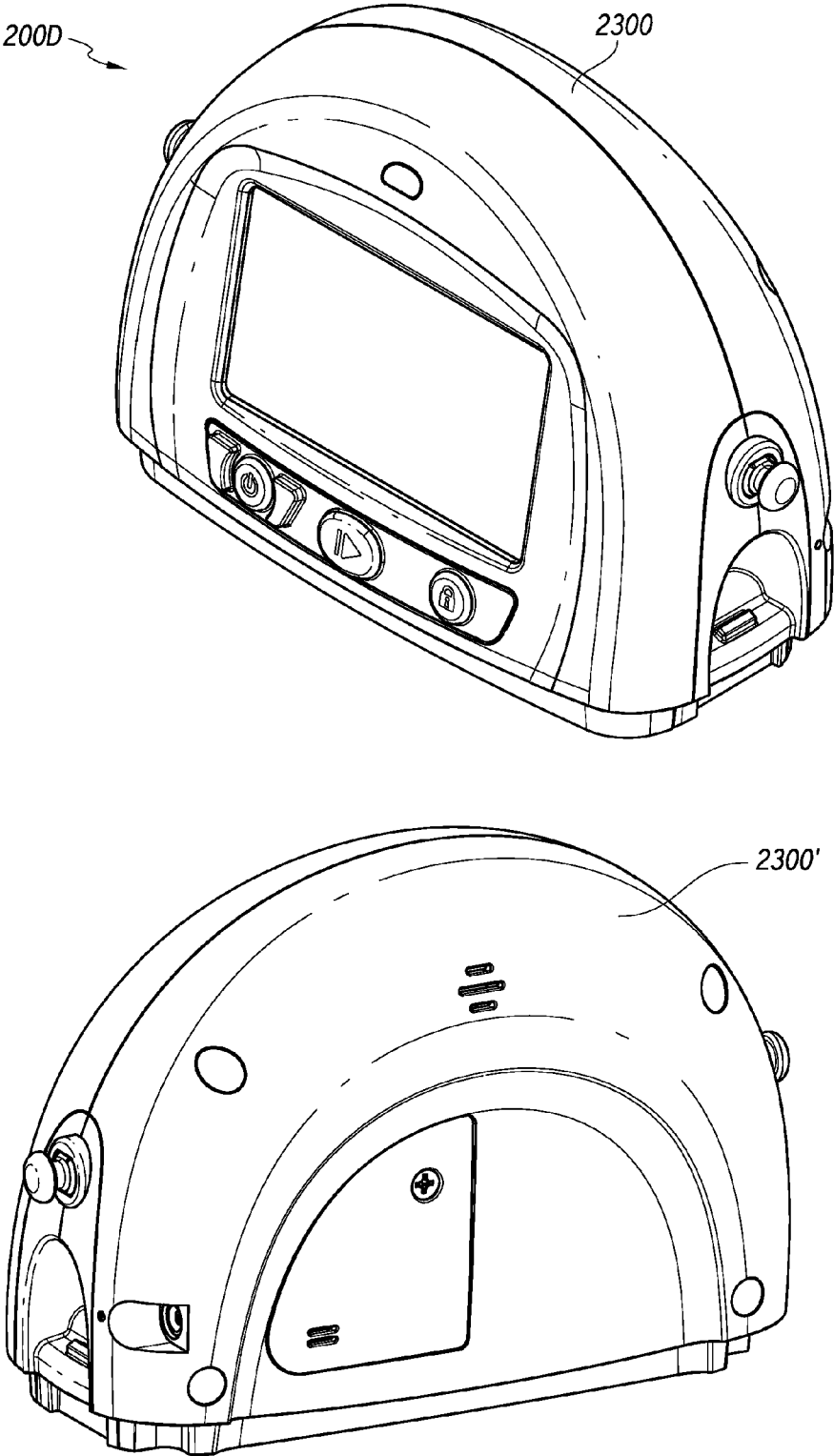

FIG. 2D

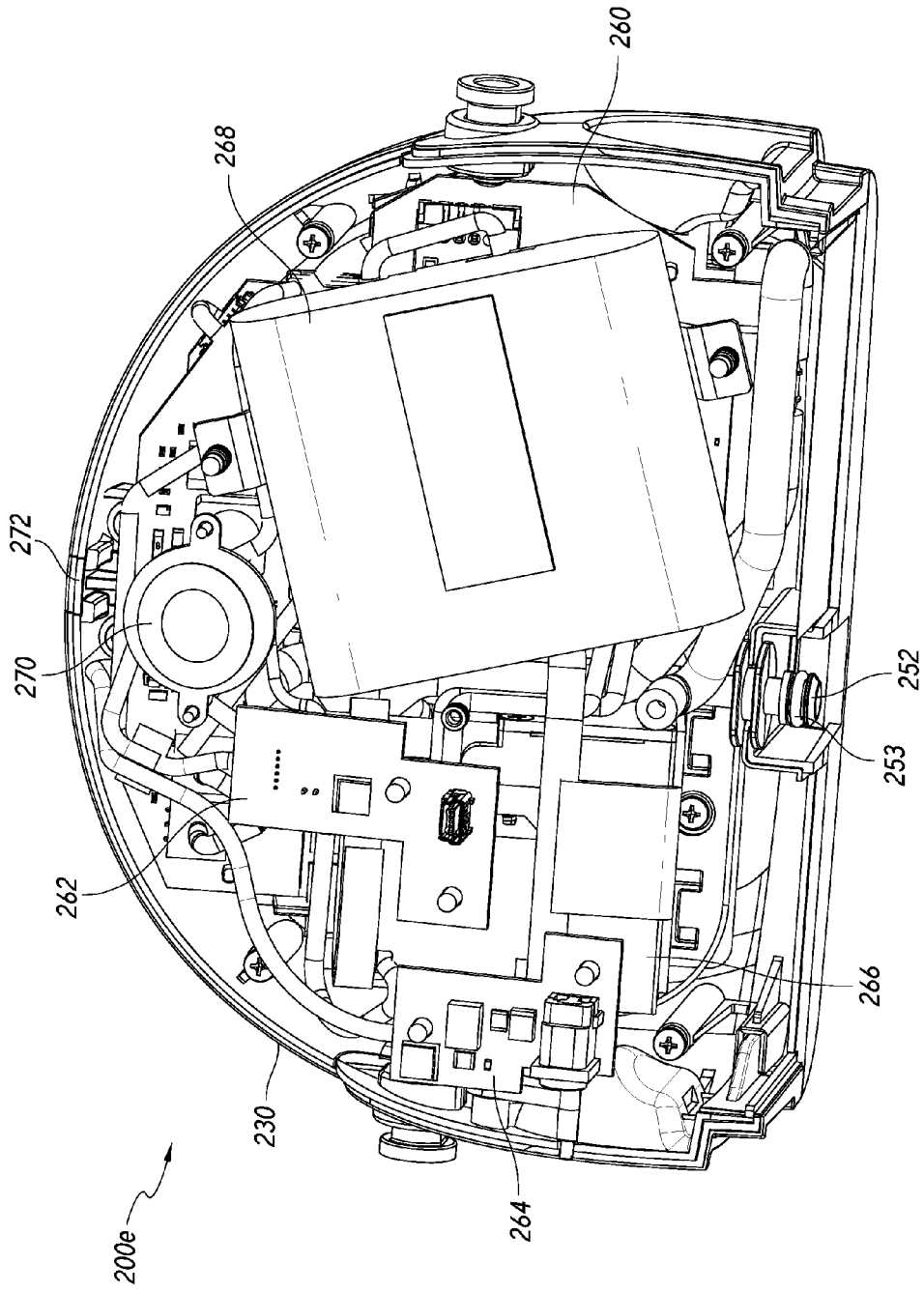

FIG. 2E

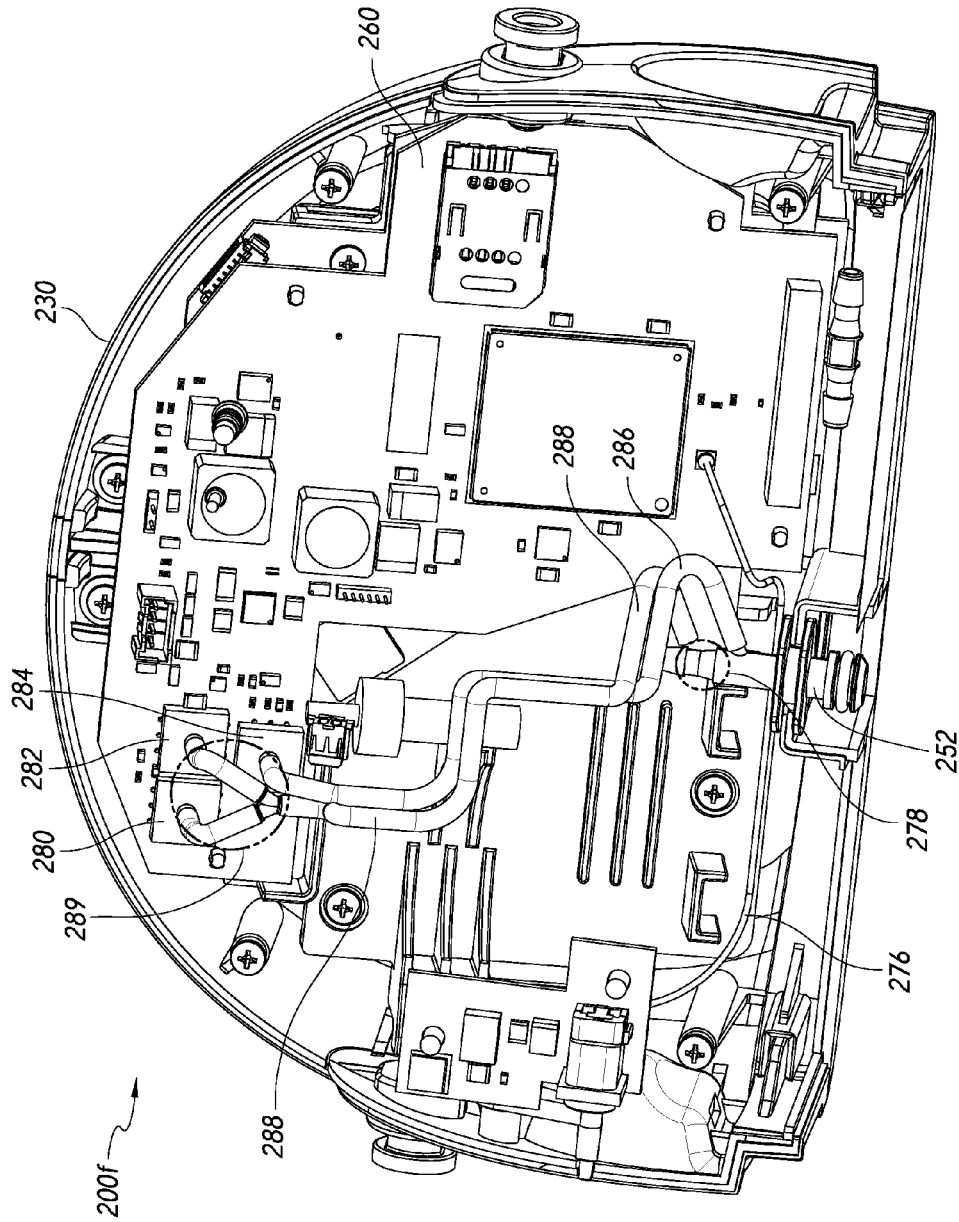

FIG. 2F

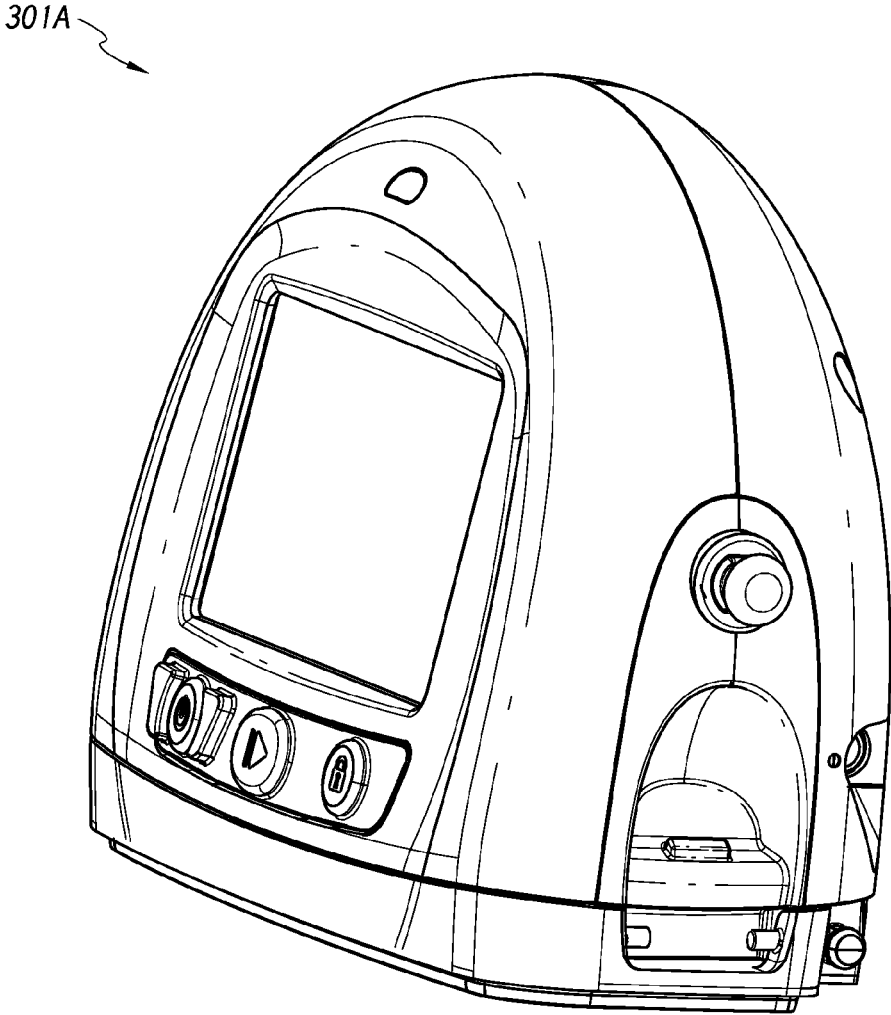

FIG. 3A-1

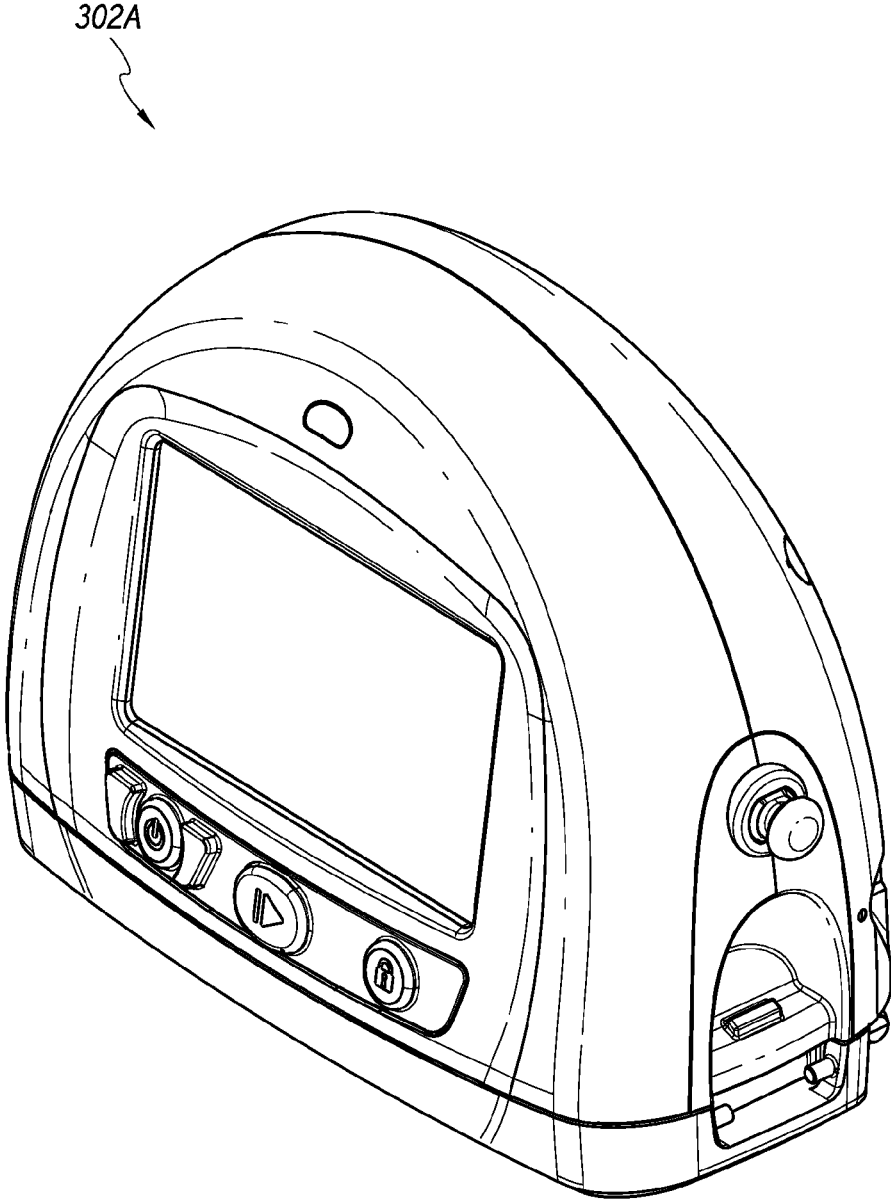

FIG. 3A-2

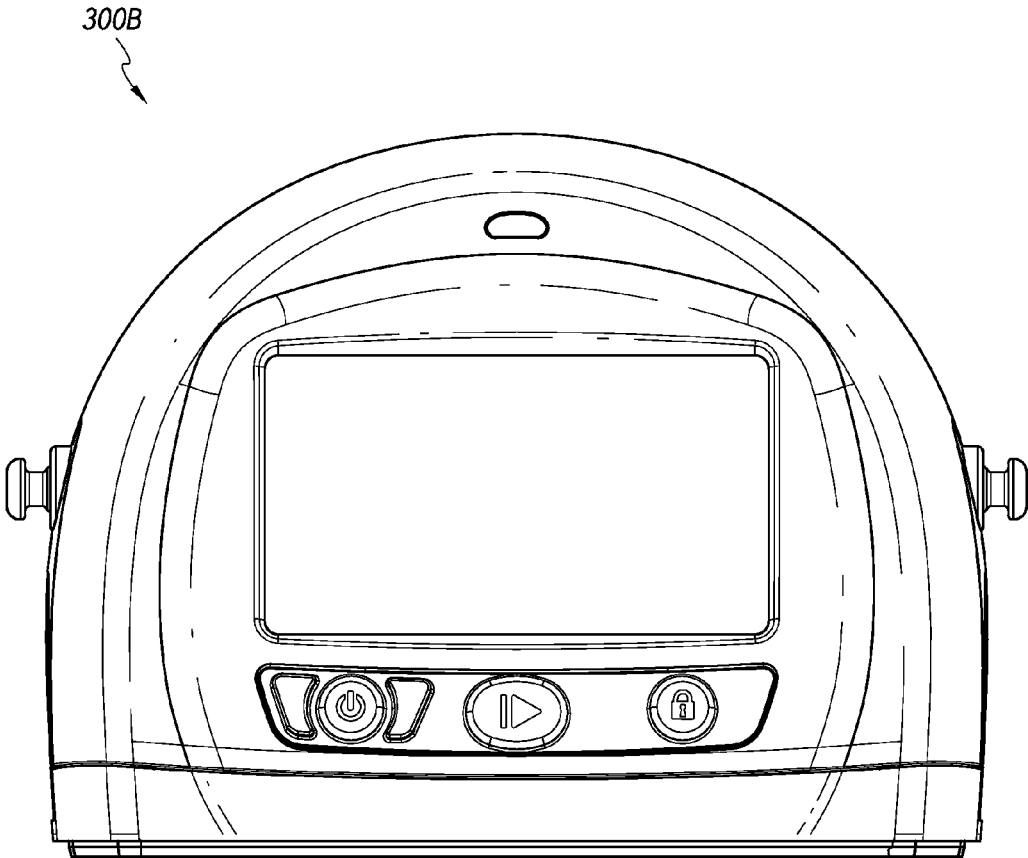

FIG. 3B

300C

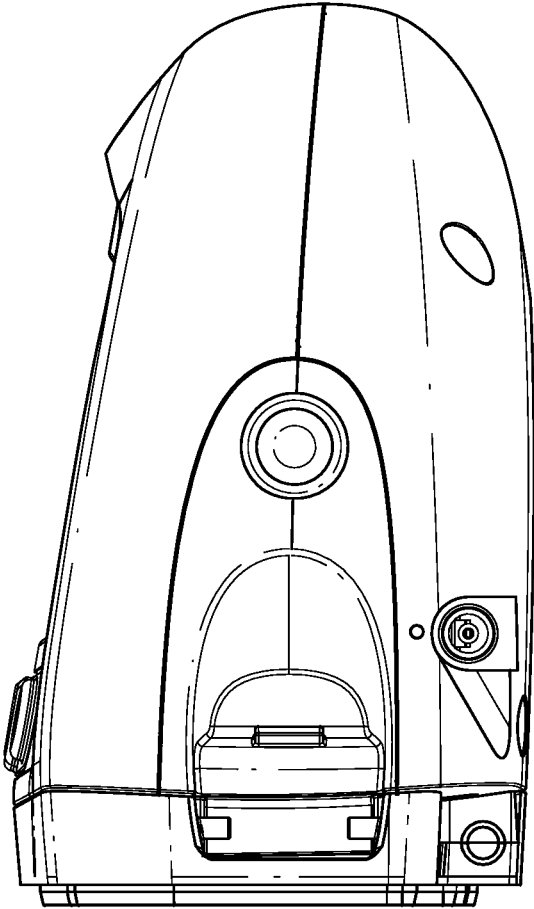

FIG. 3C

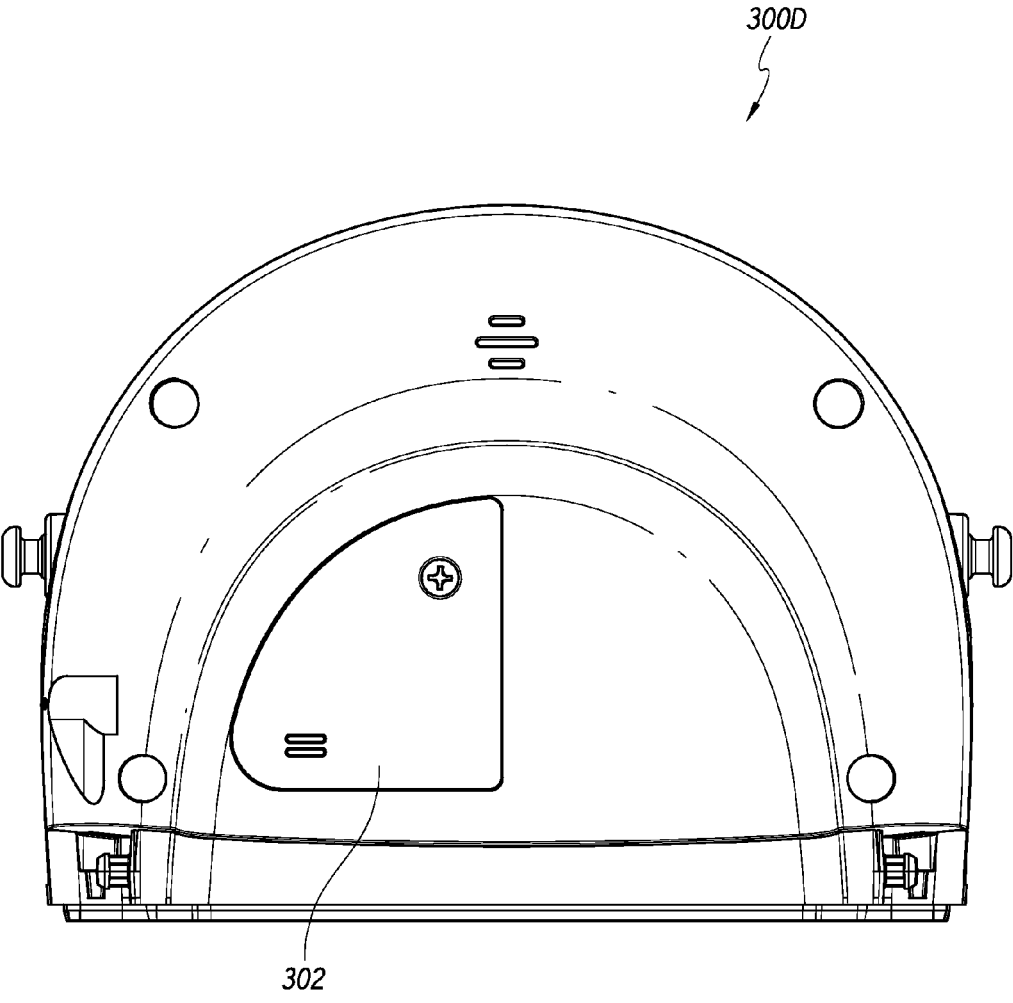

FIG. 3D

300E

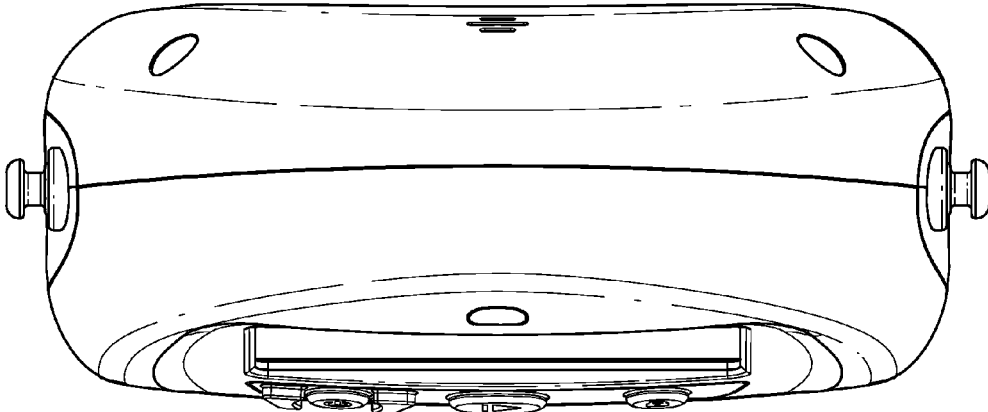

FIG. 3E

300F

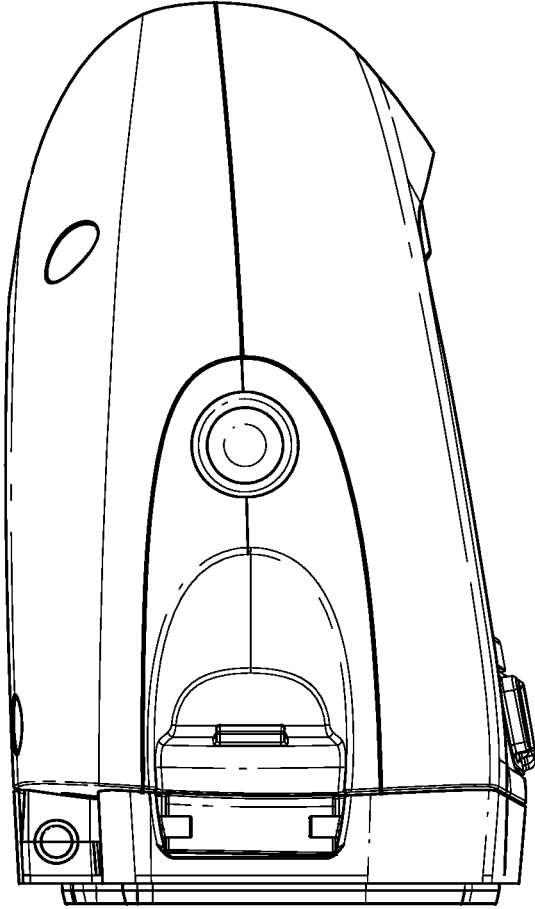

FIG. 3F

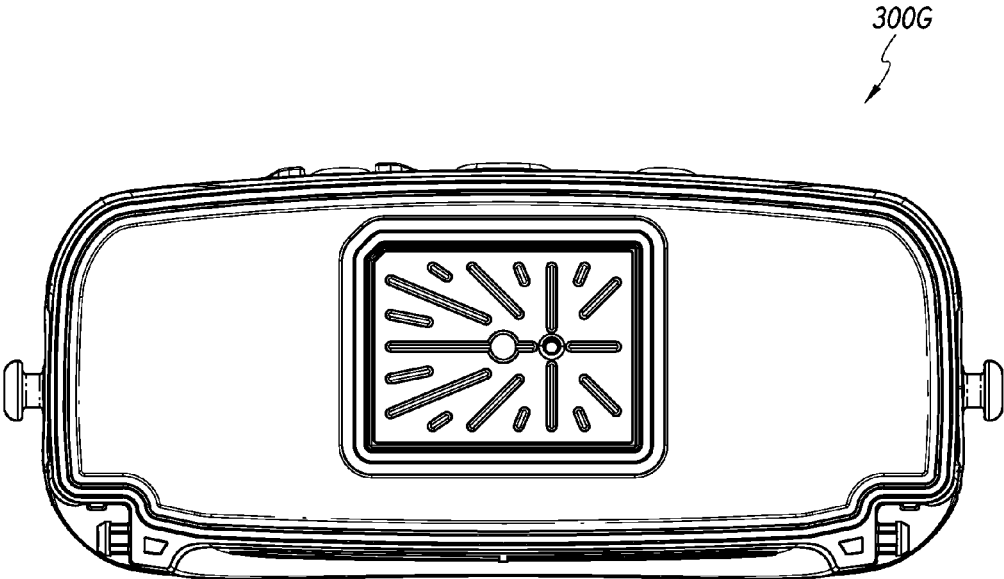

FIG. 3G

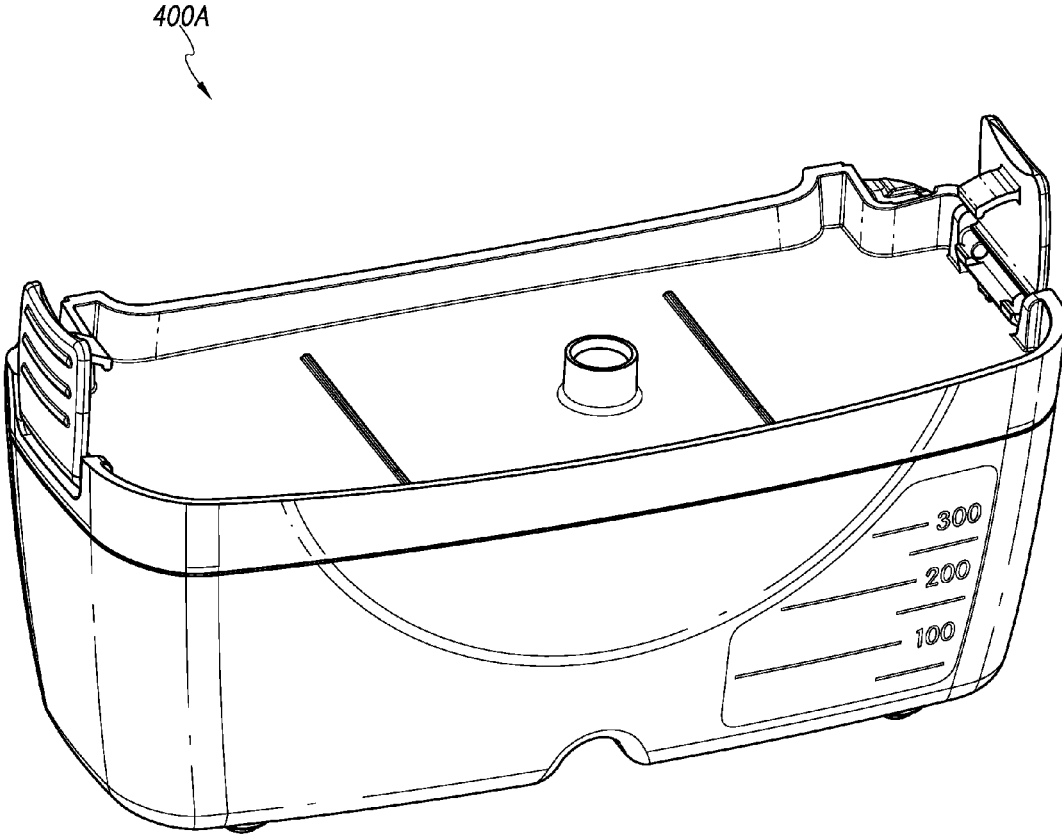

FIG. 4A-1

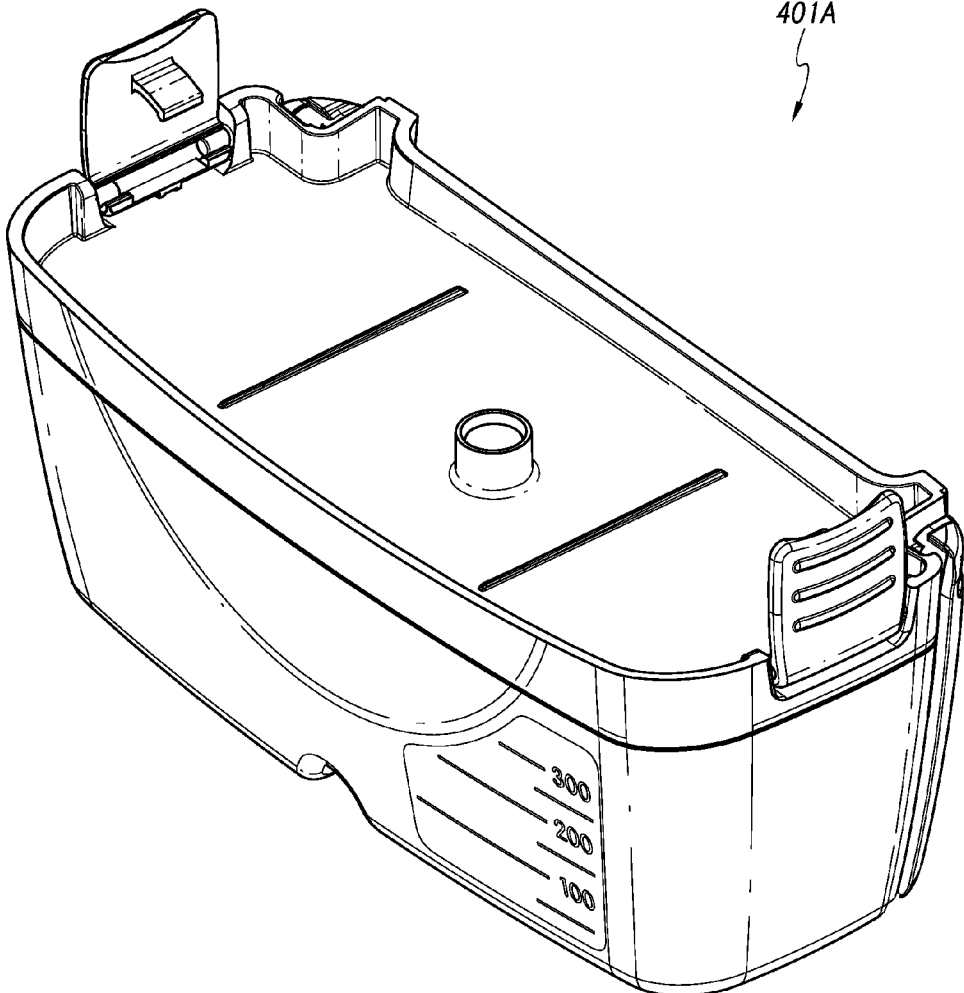

FIG. 4A-2

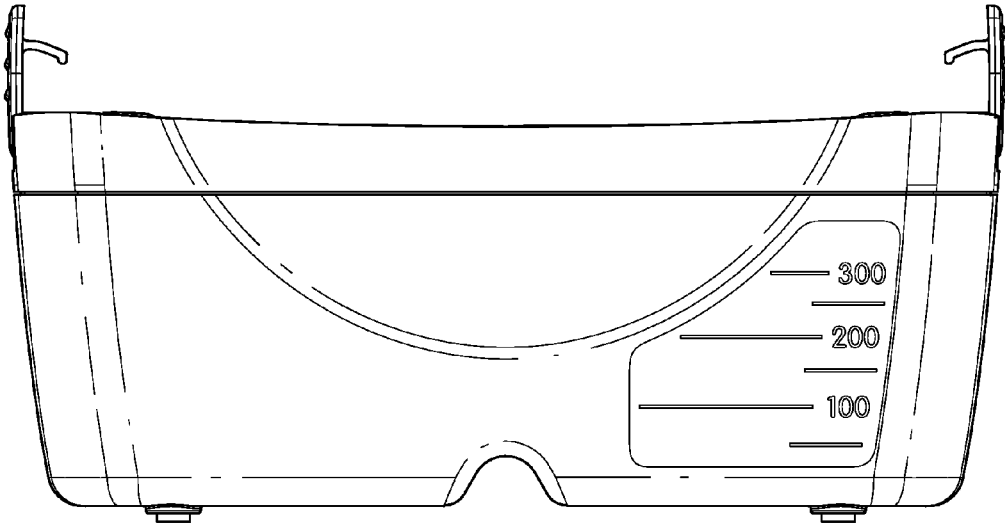

FIG. 4B

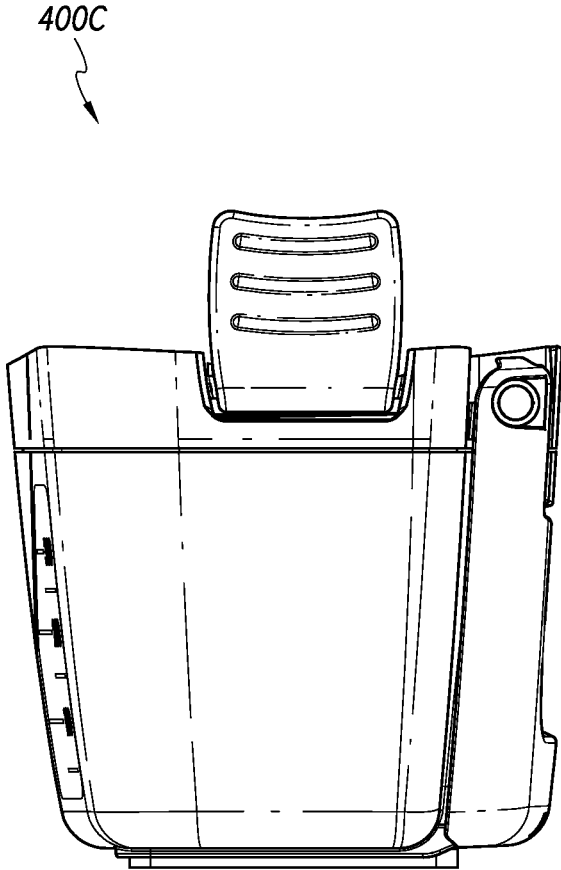

FIG. 4C

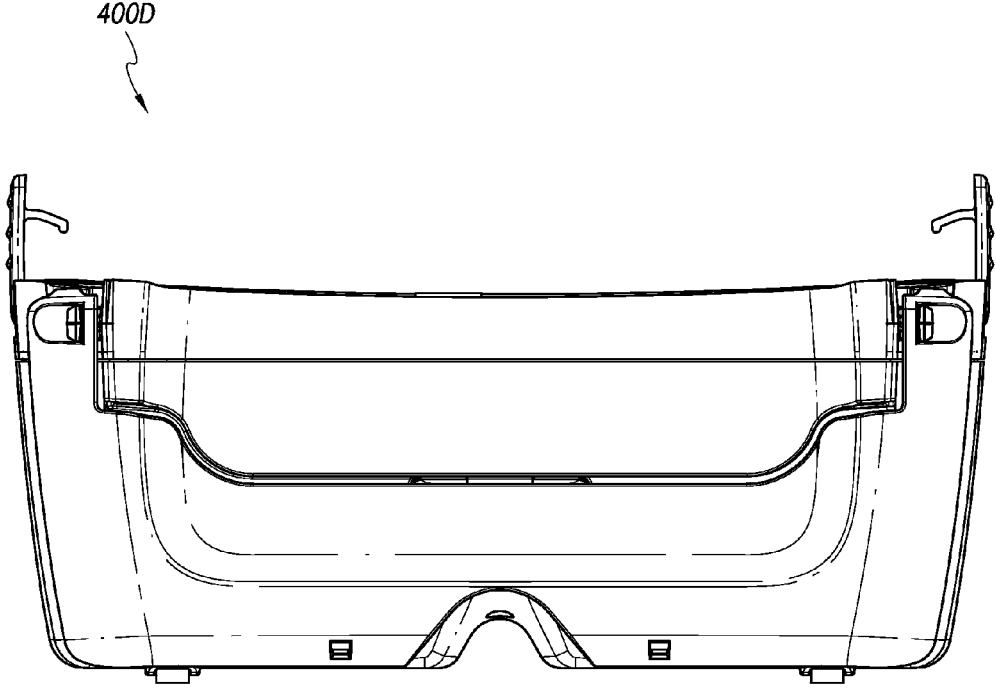

FIG. 4D

400E

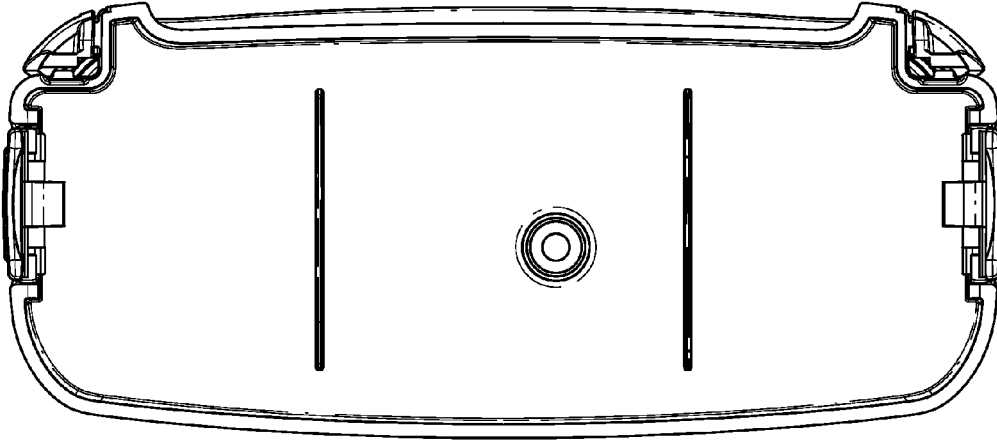

FIG. 4E

400F

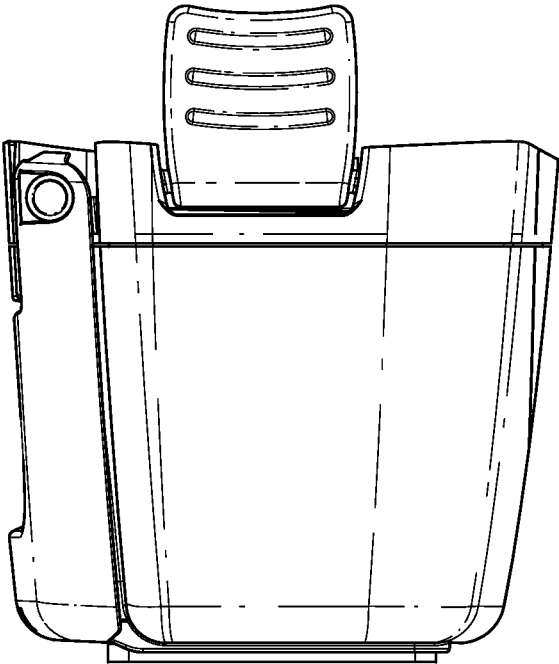

FIG. 4F

400G

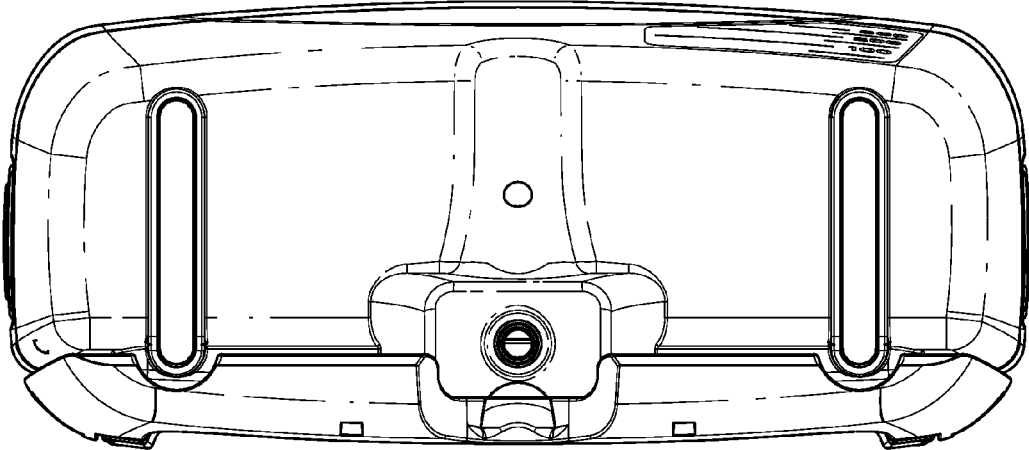

FIG. 4G

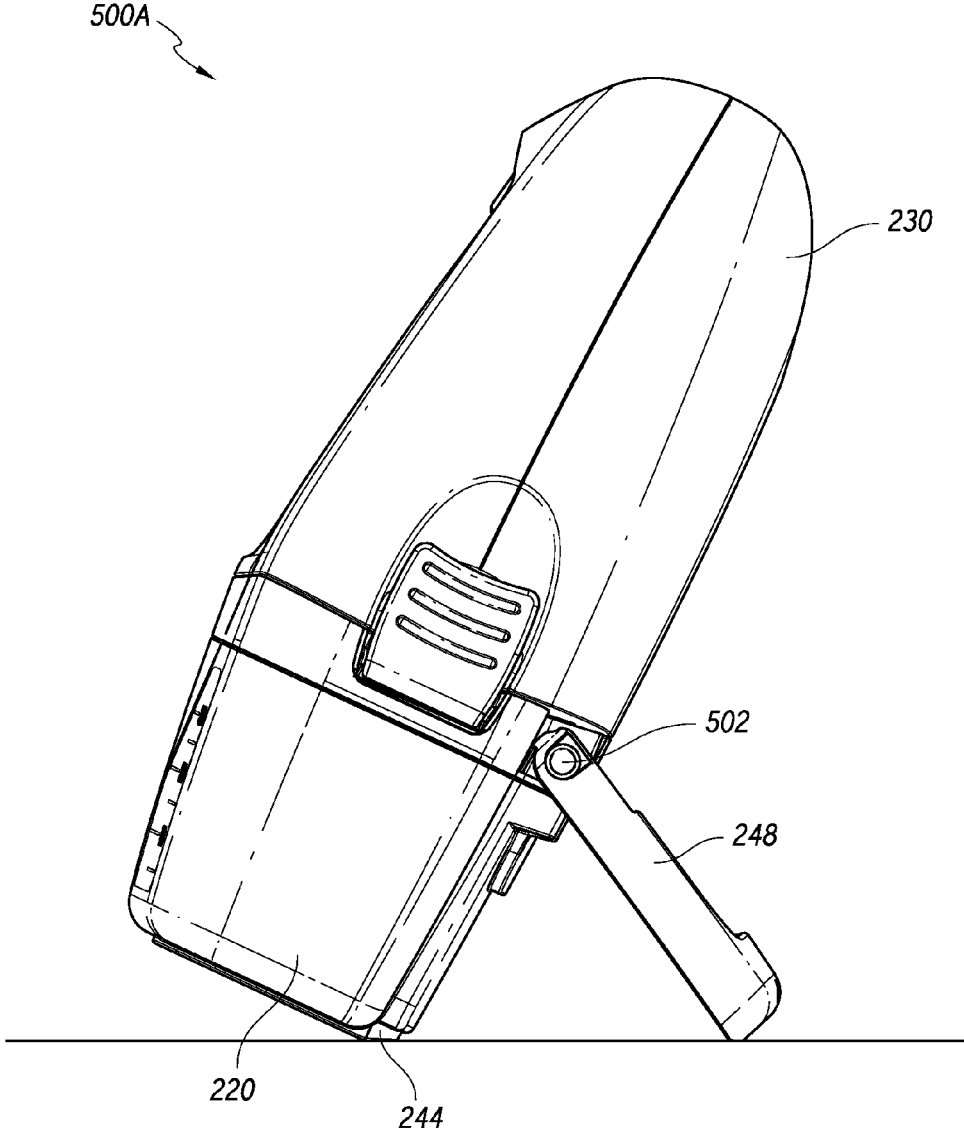

FIG. 5A

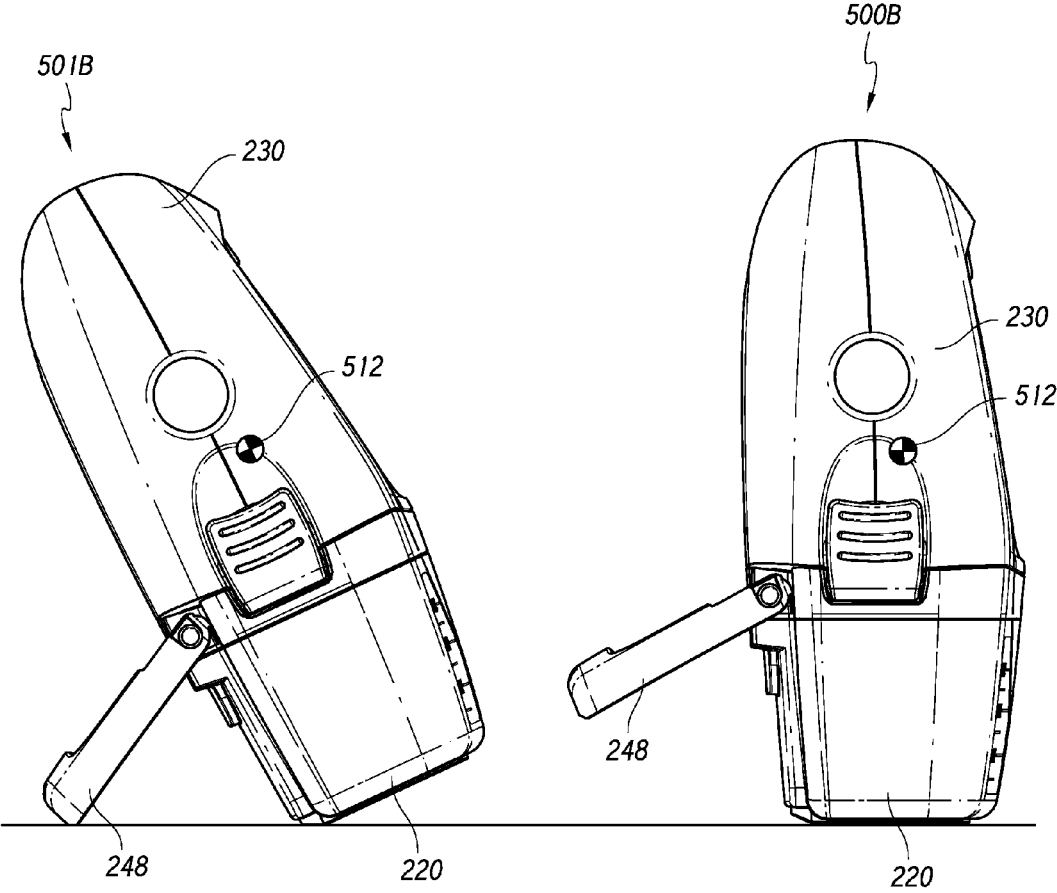

FIG. 5B

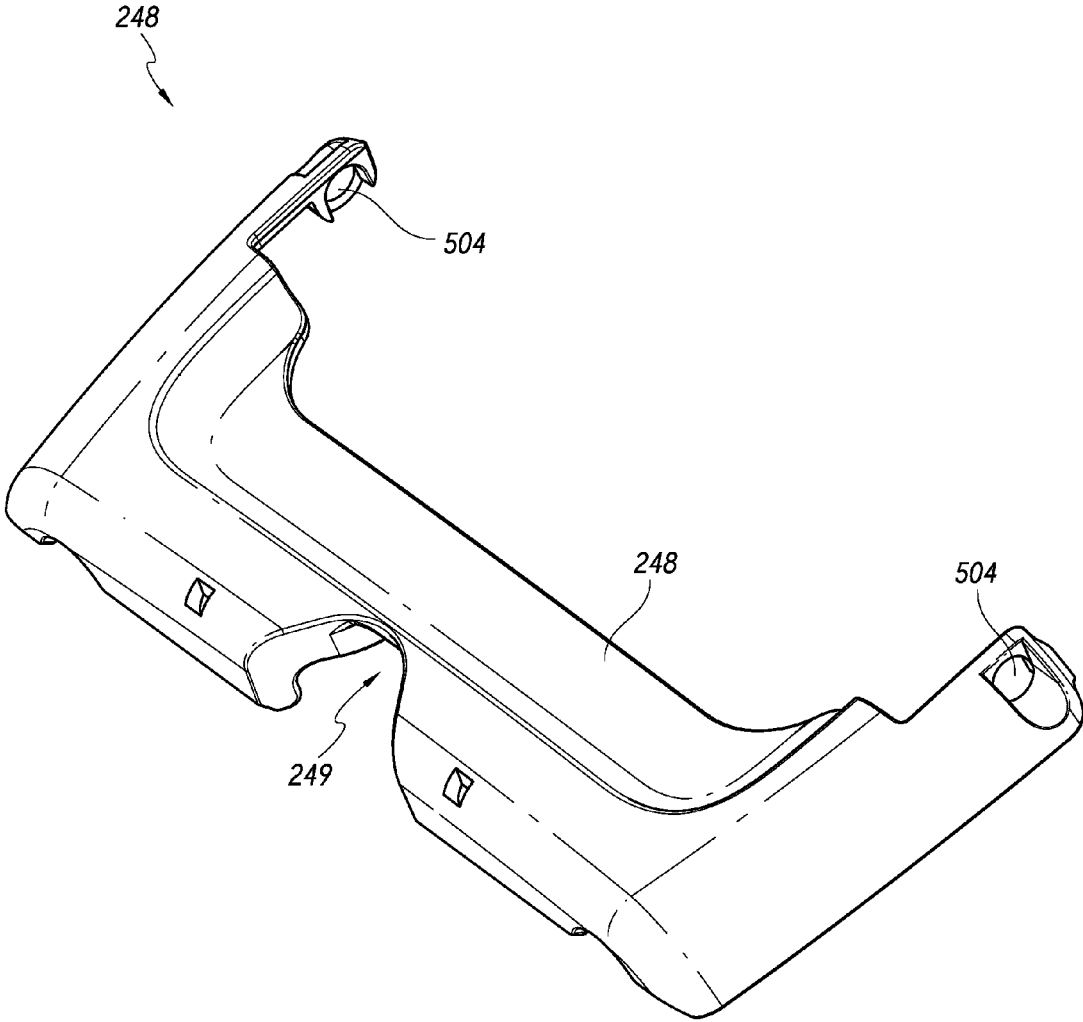

FIG. 5C

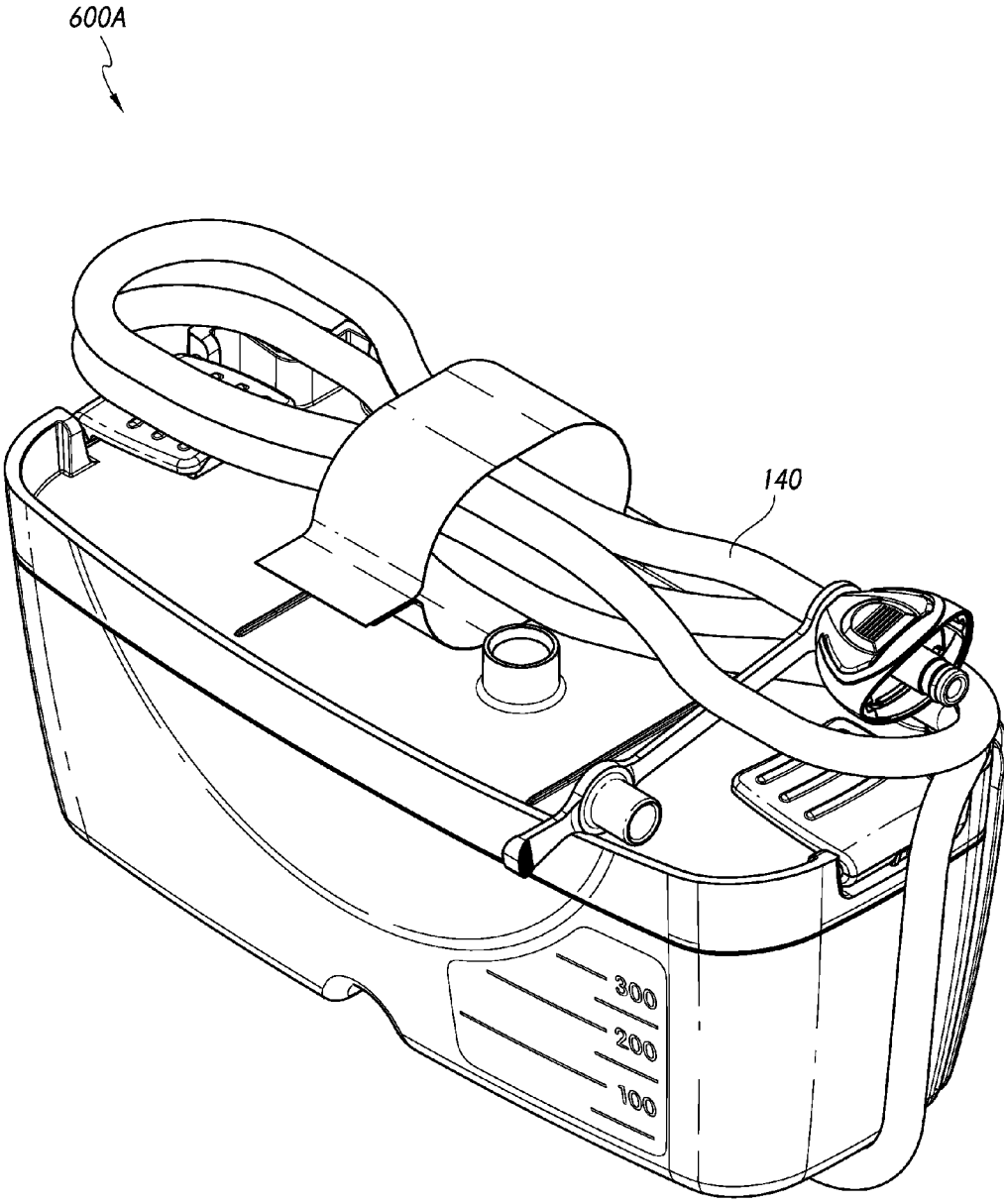

FIG. 6A

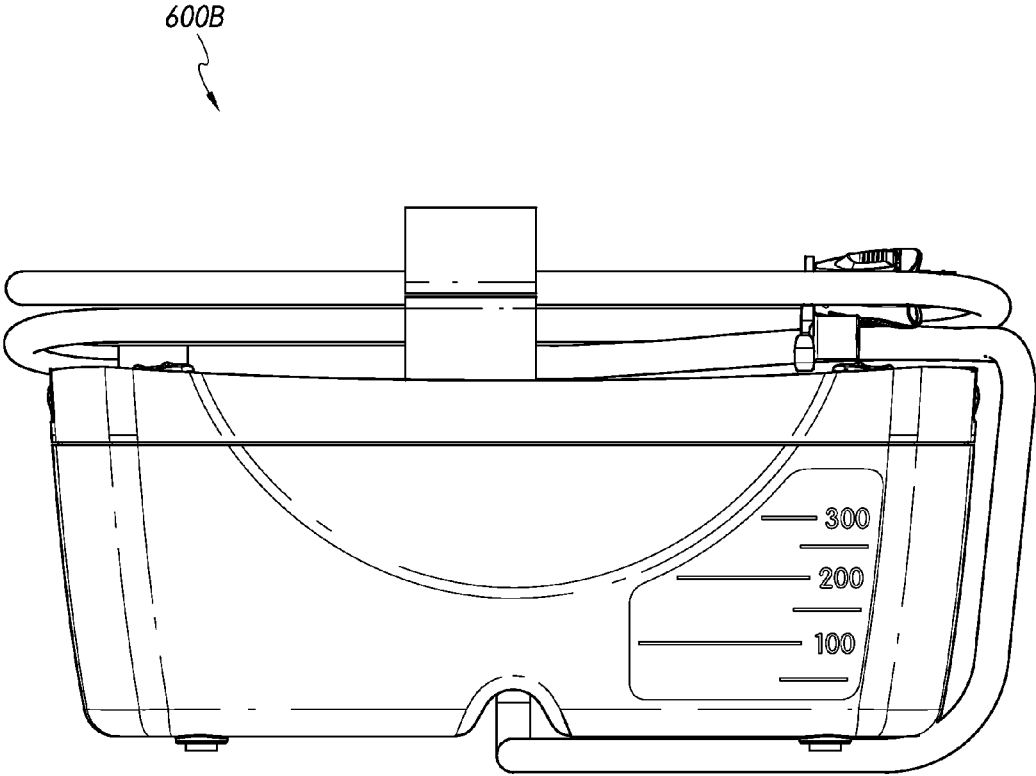

FIG. 6B

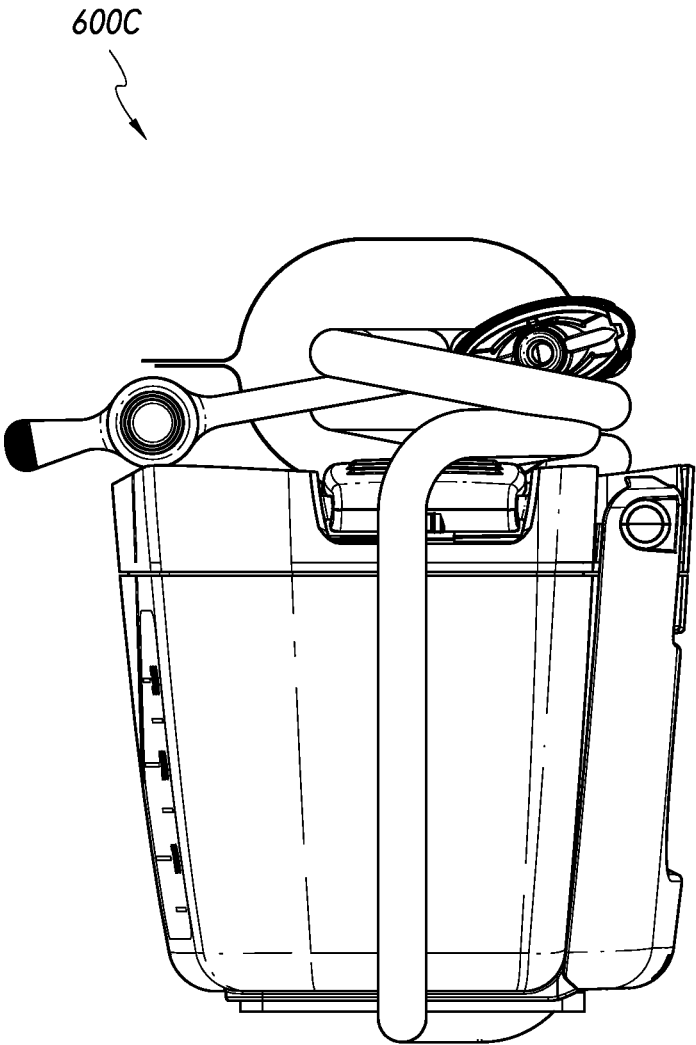

FIG. 6C

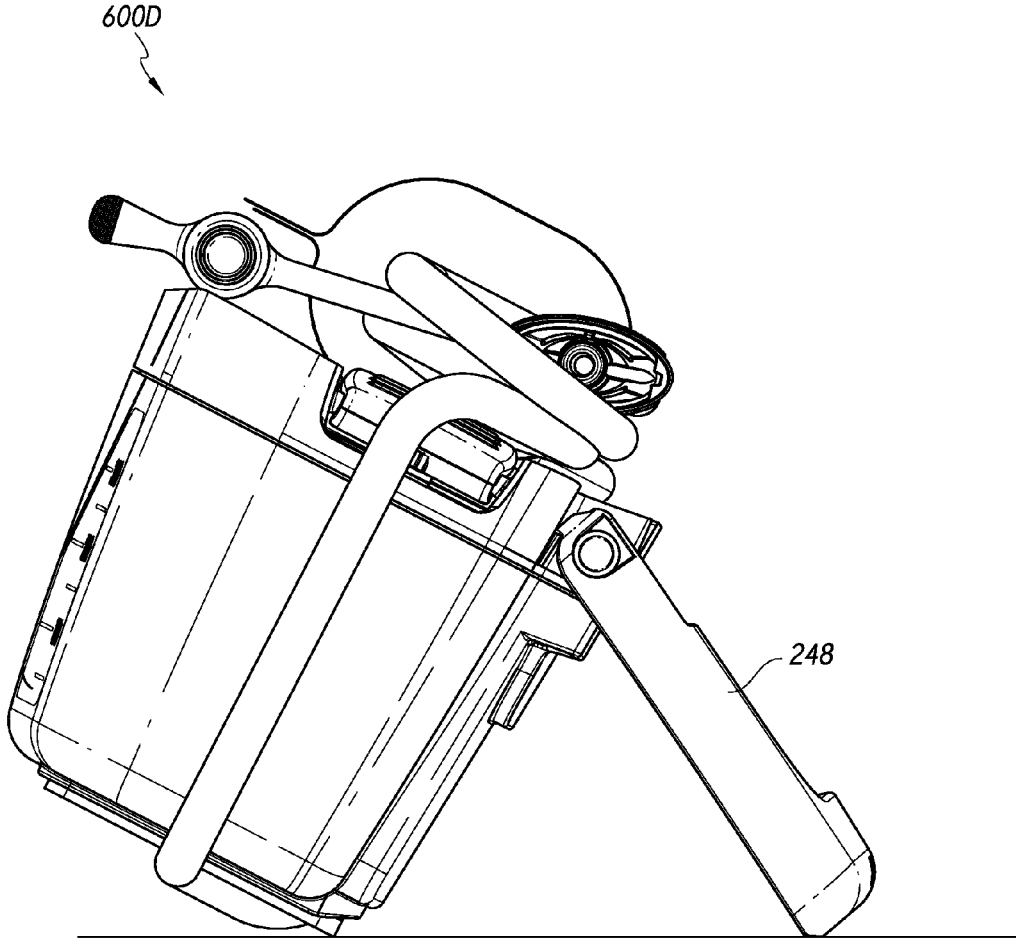

FIG. 6D

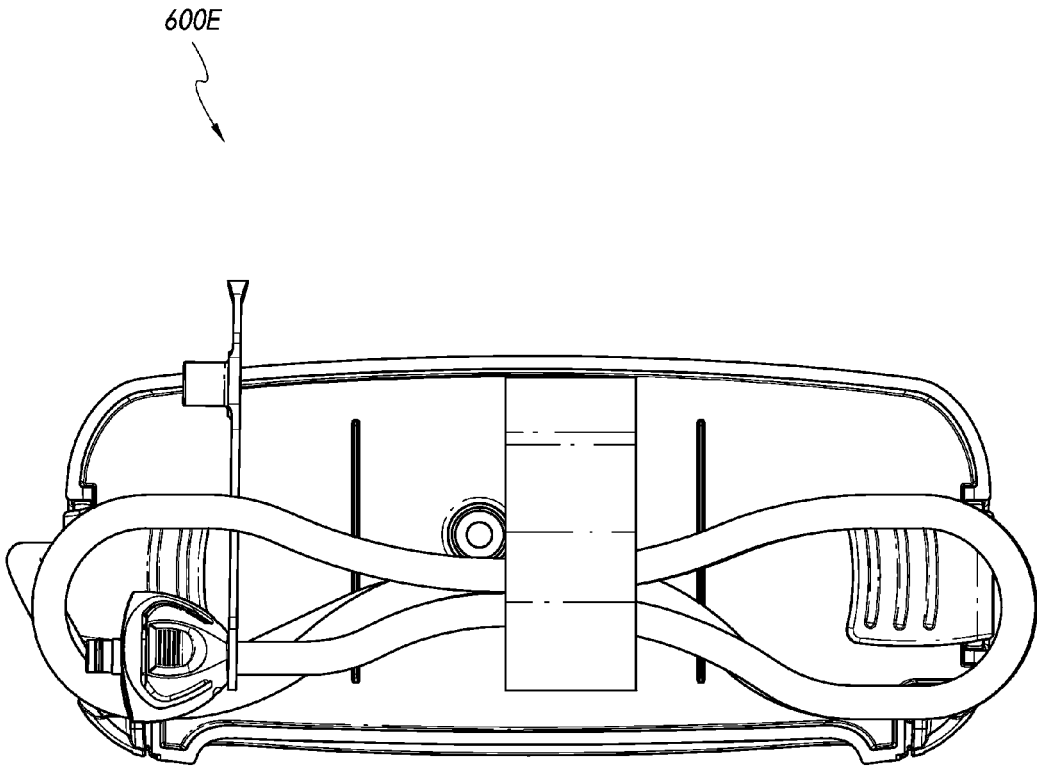

FIG. 6E

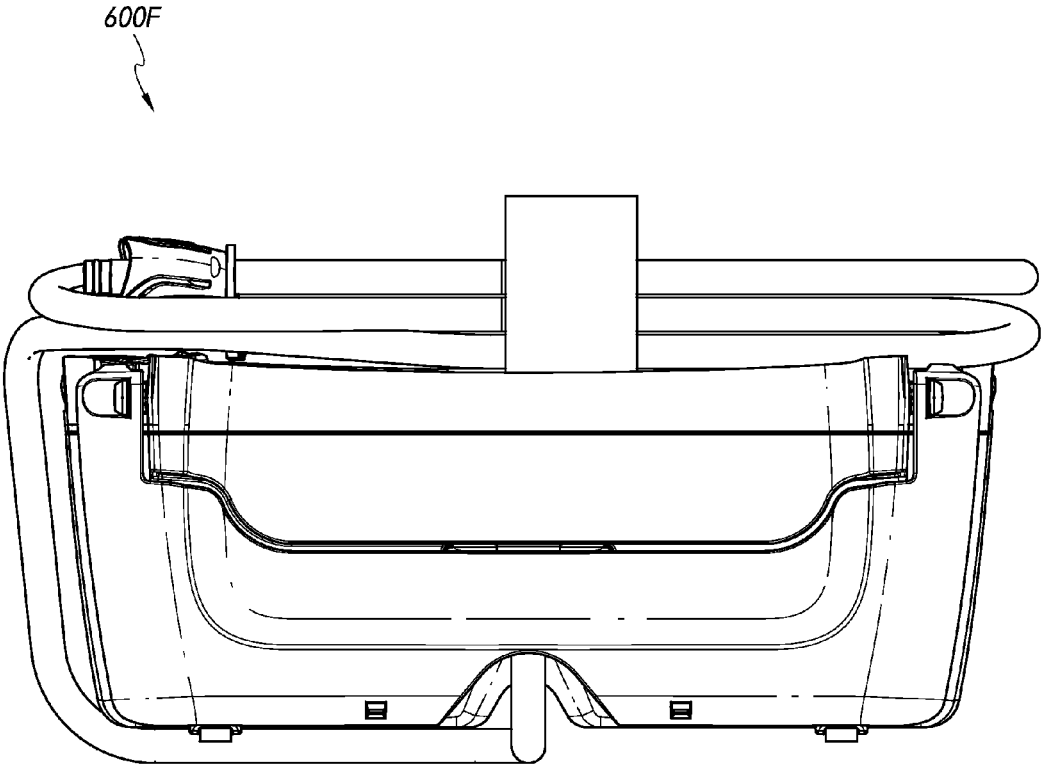

FIG. 6F

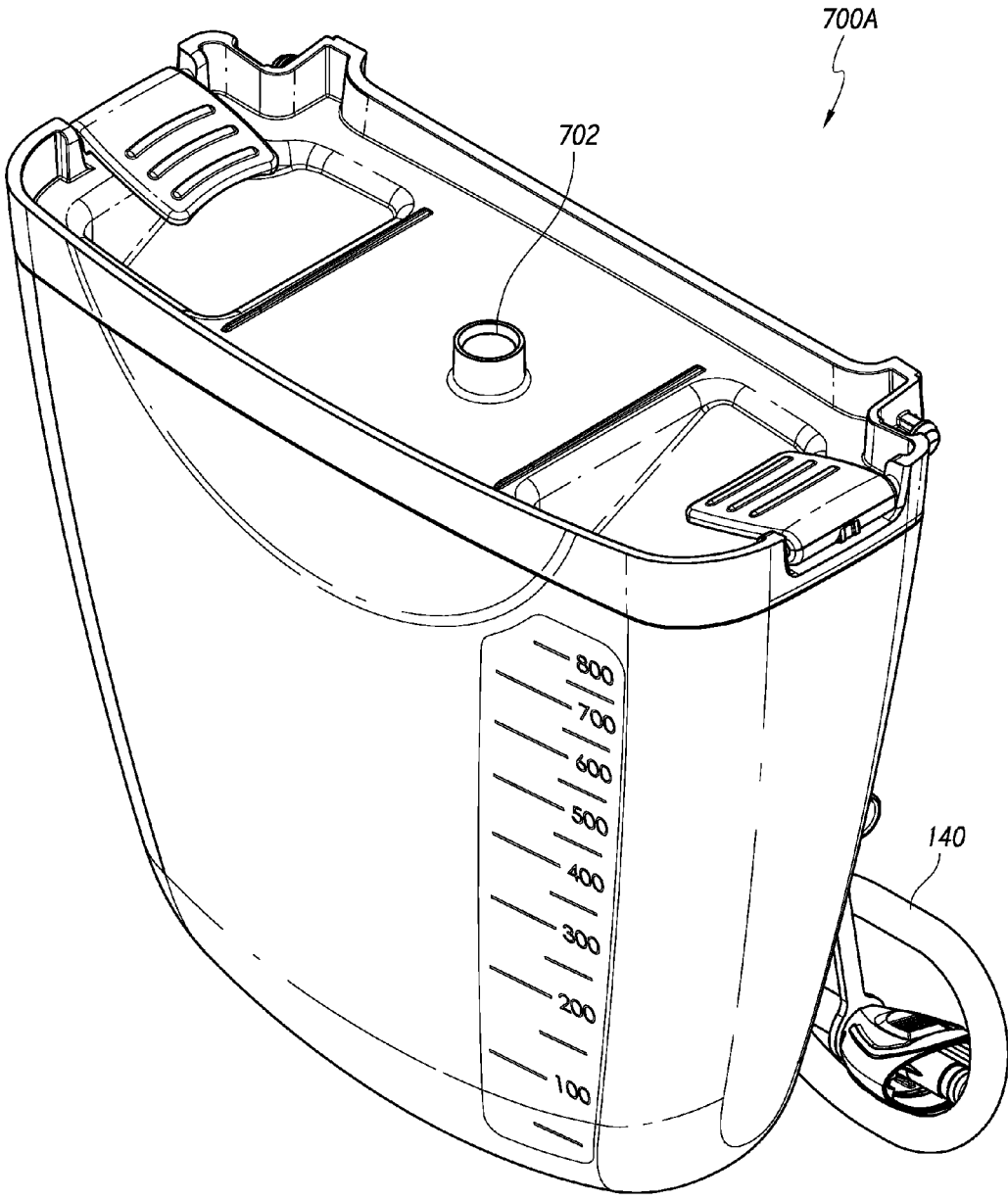

FIG. 7A

700B

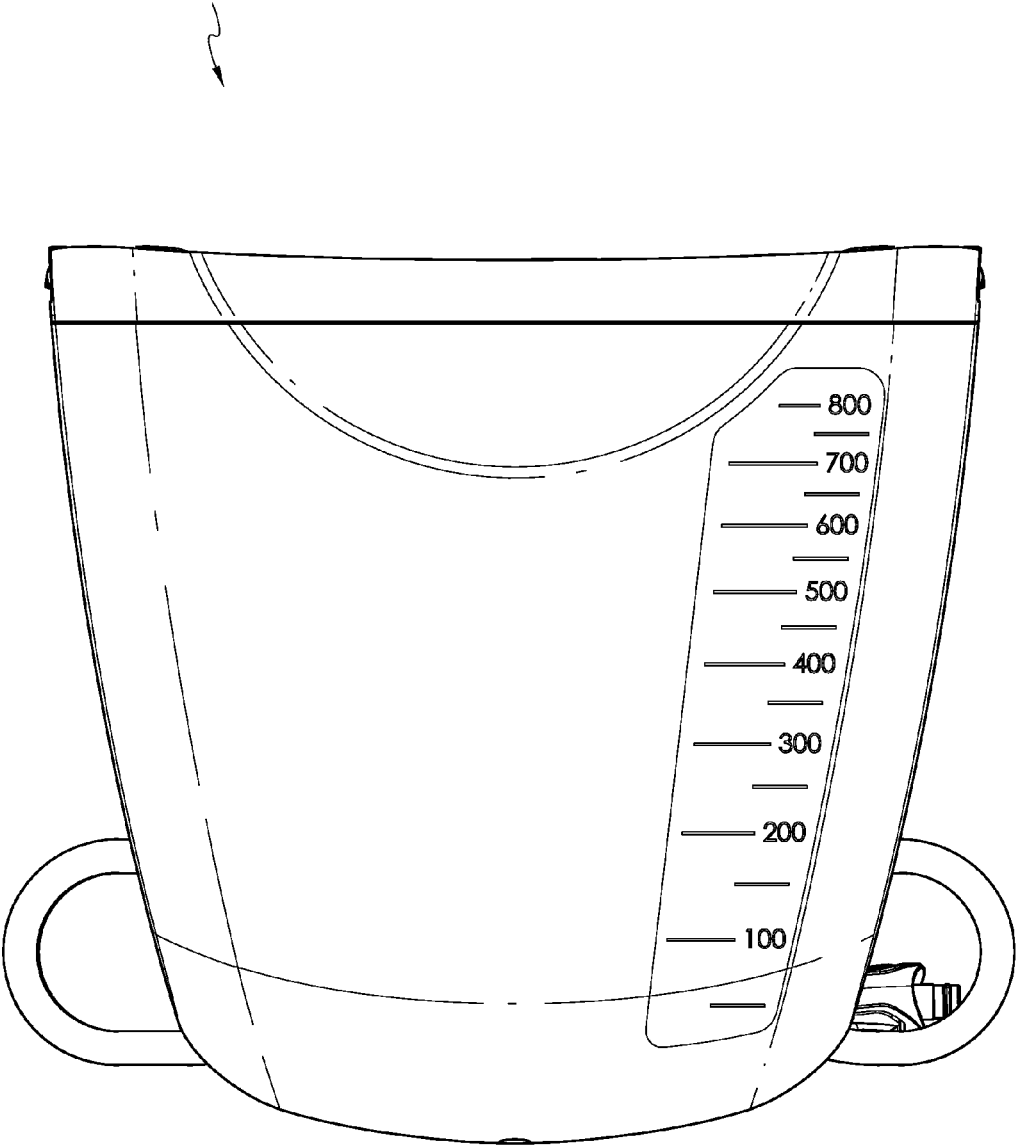

FIG. 7B

700C

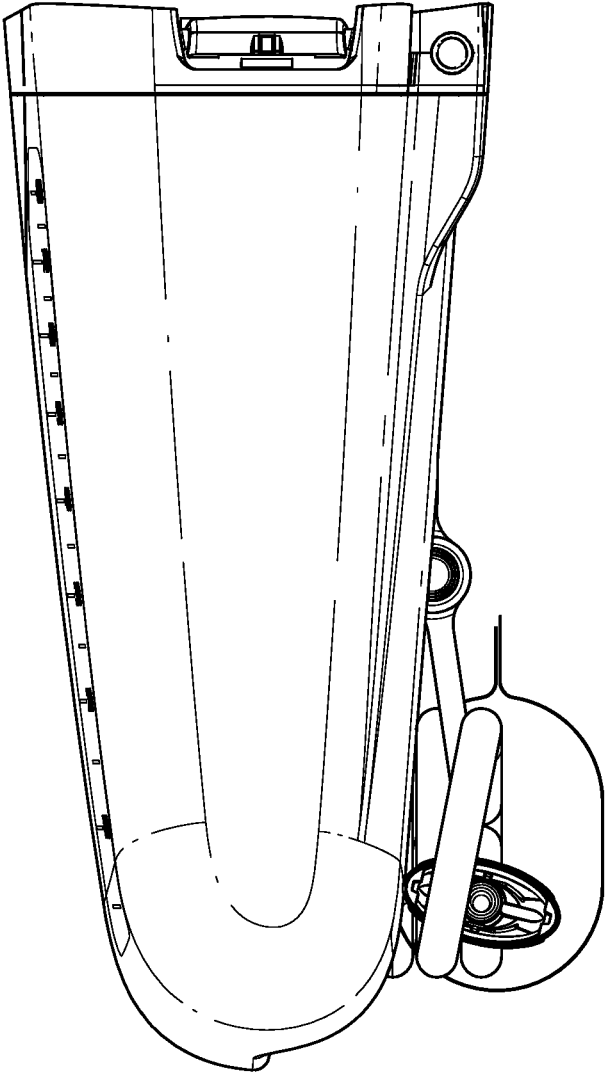

FIG. 7C

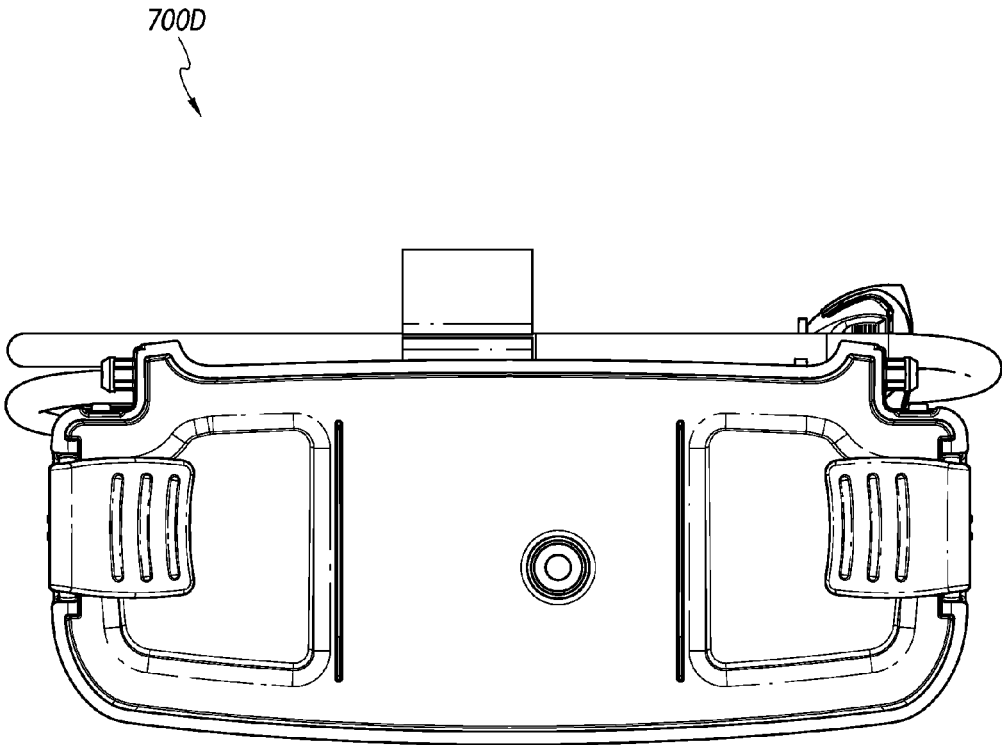

FIG. 7D

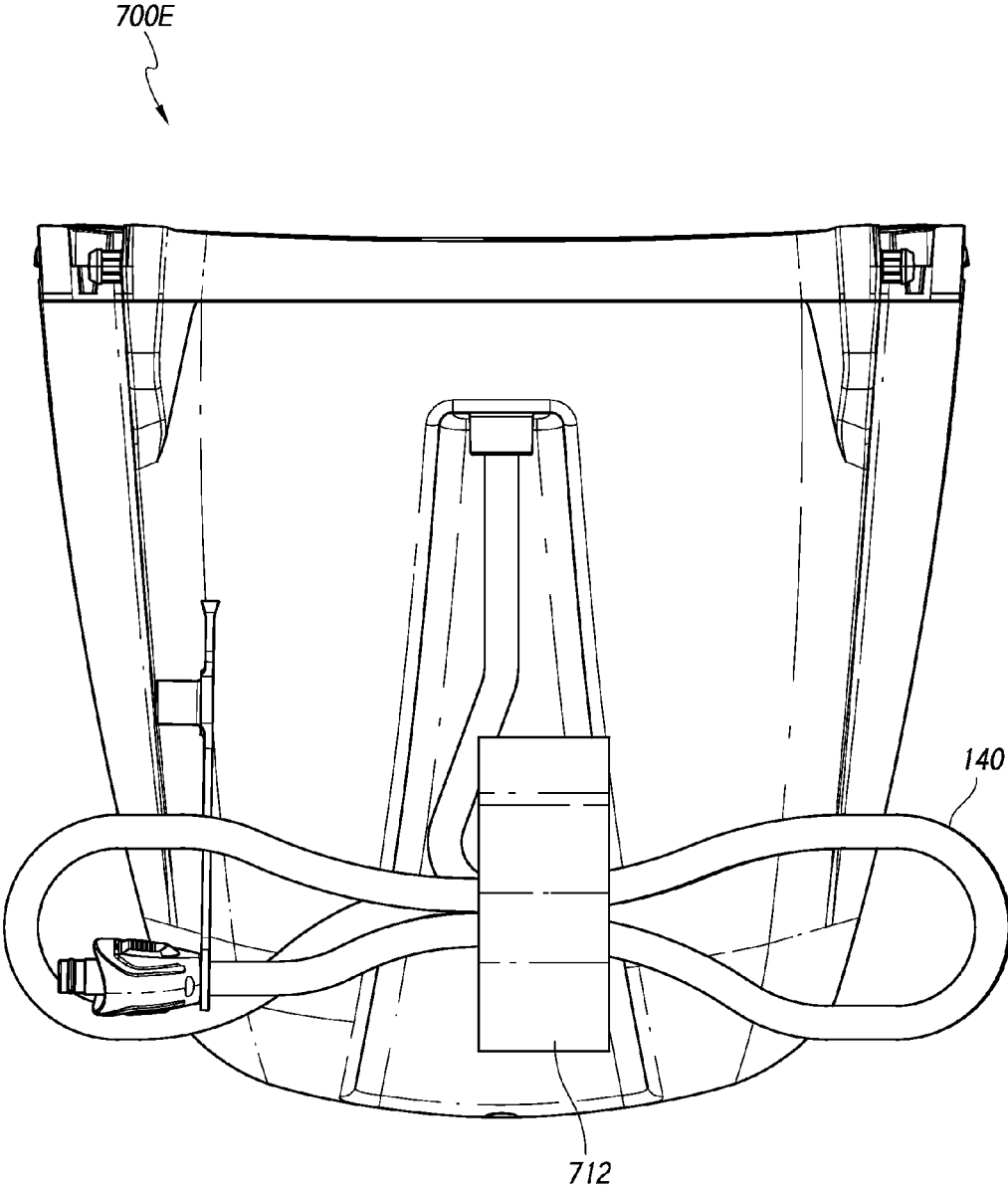

FIG. 7E

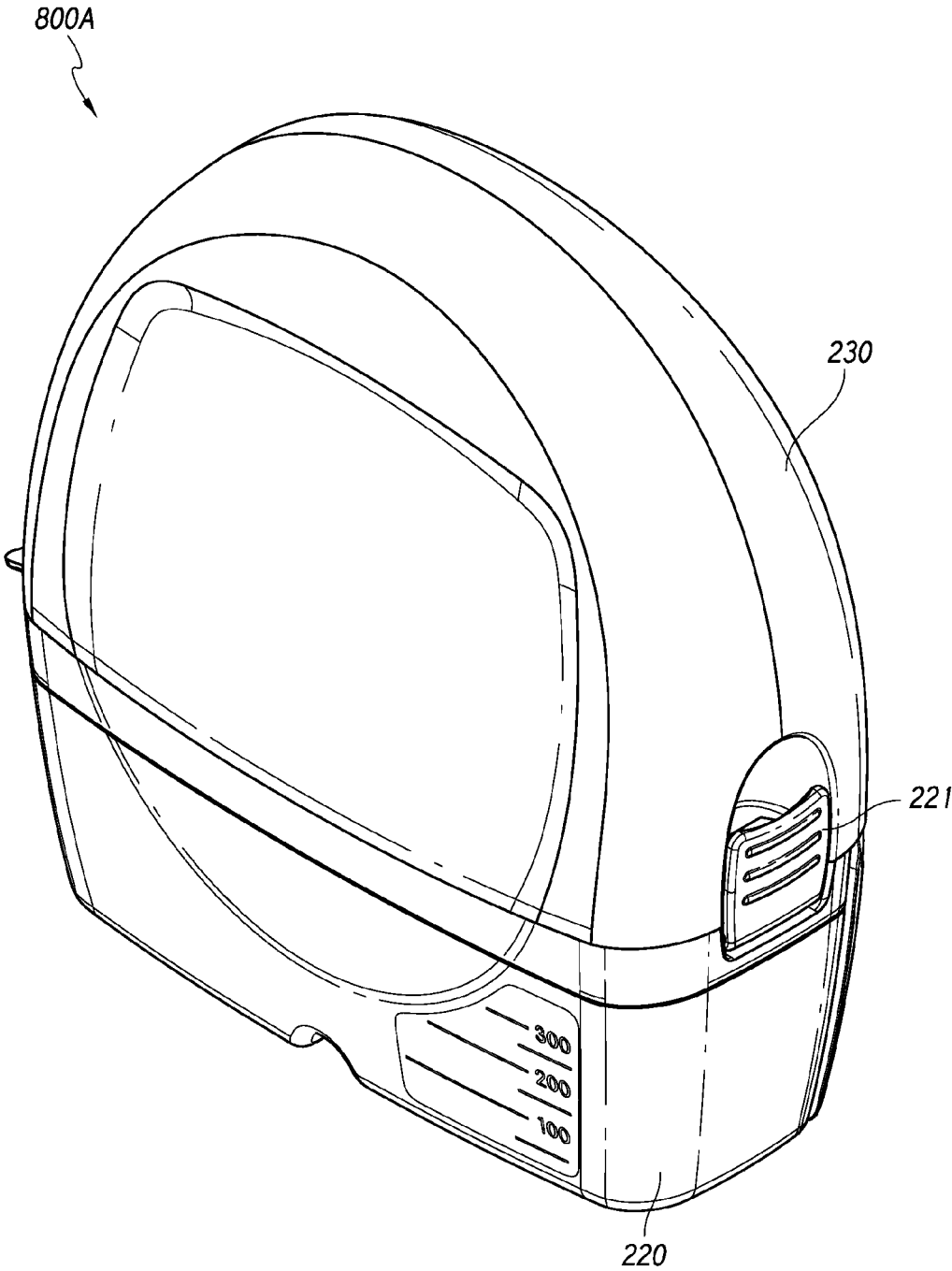

FIG. 8A

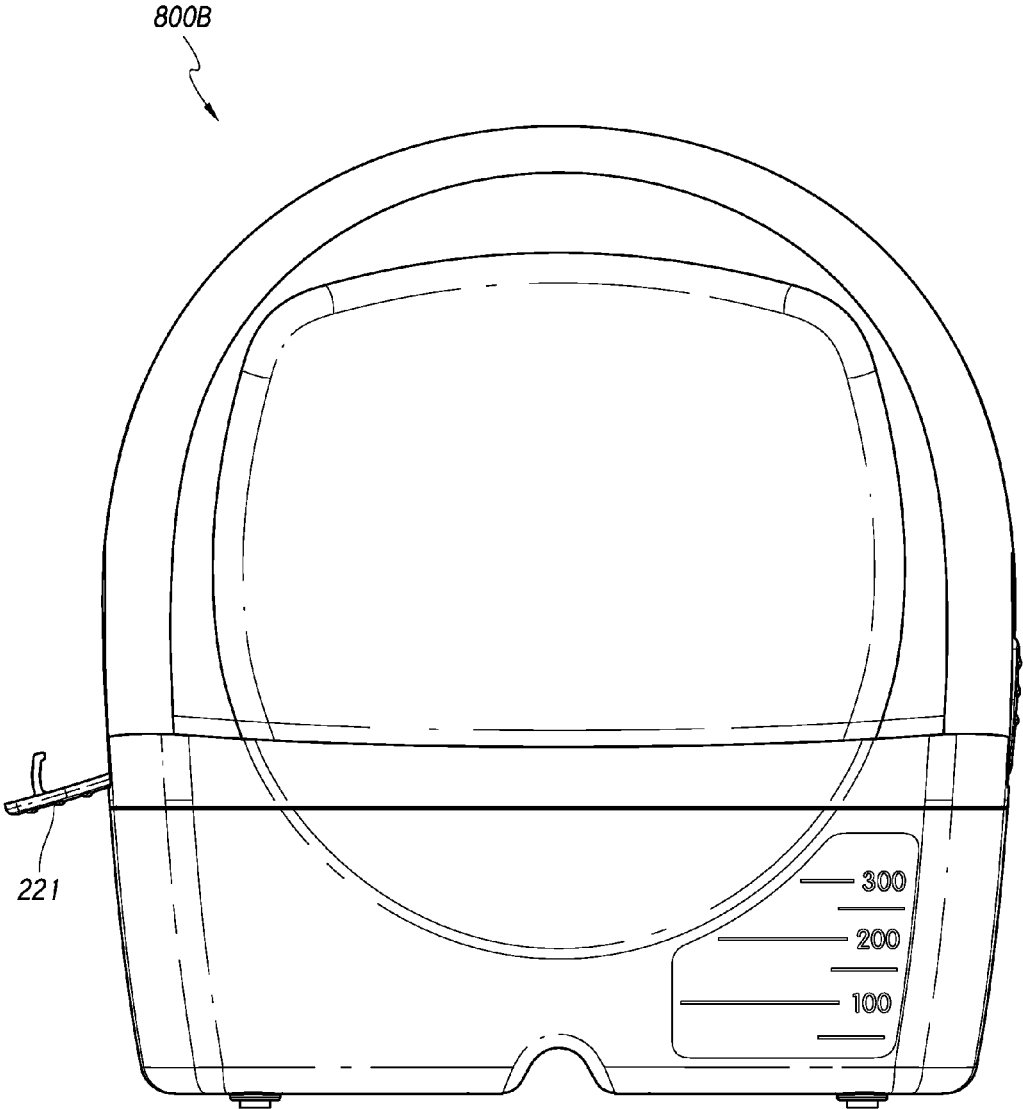

FIG. 8B

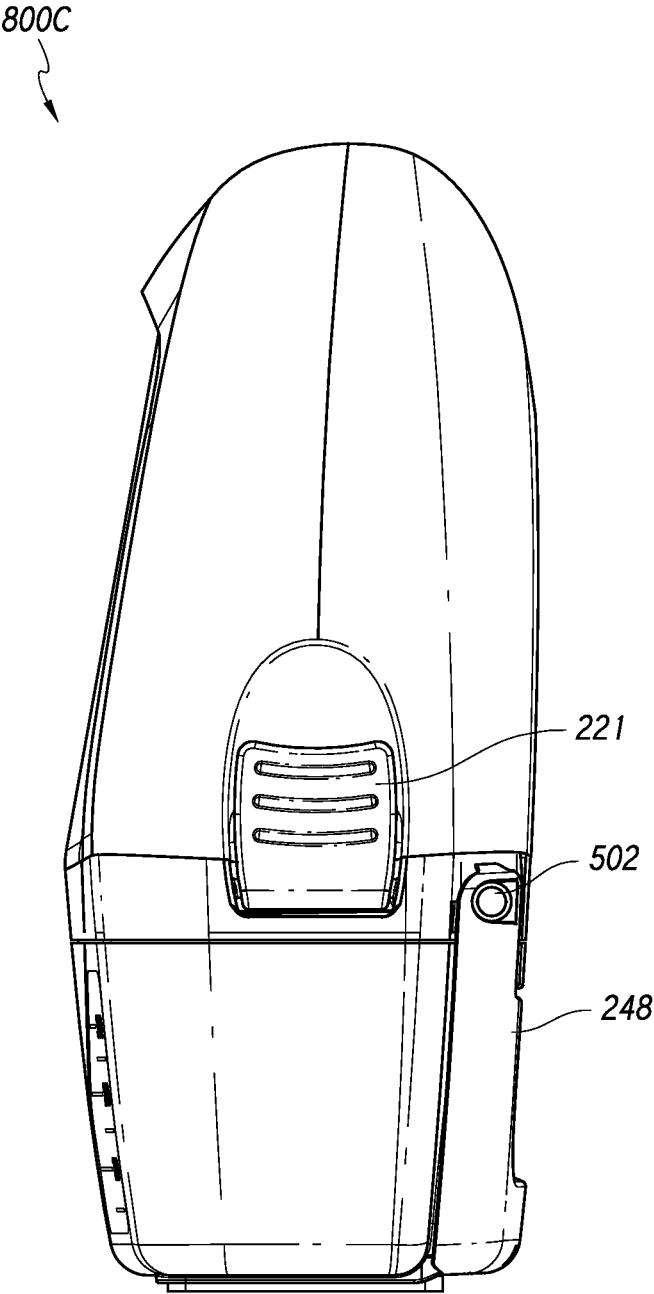

FIG. 8C

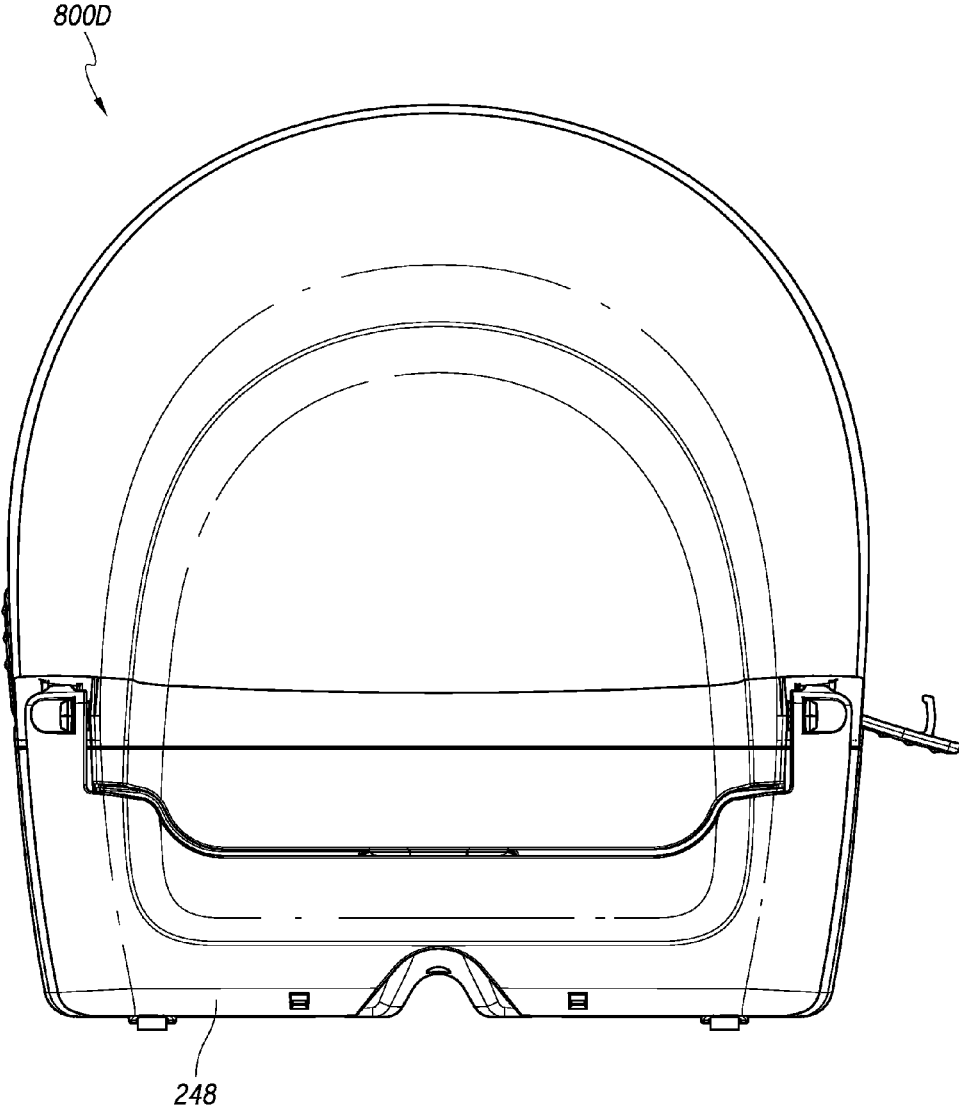

FIG. 8D

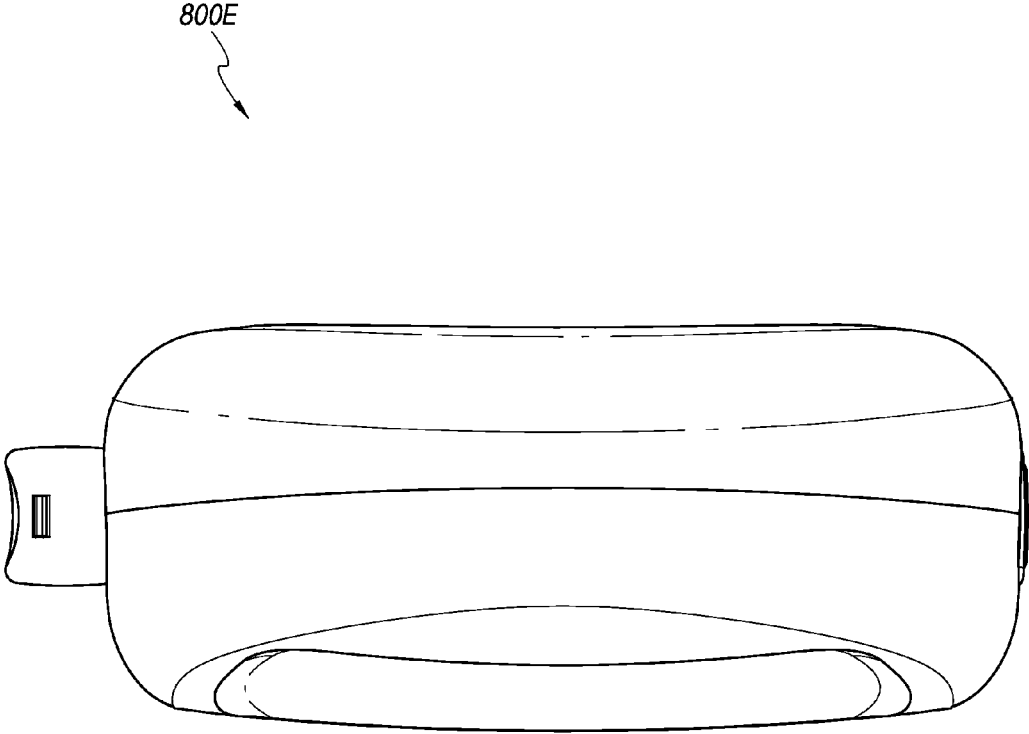

FIG. 8E

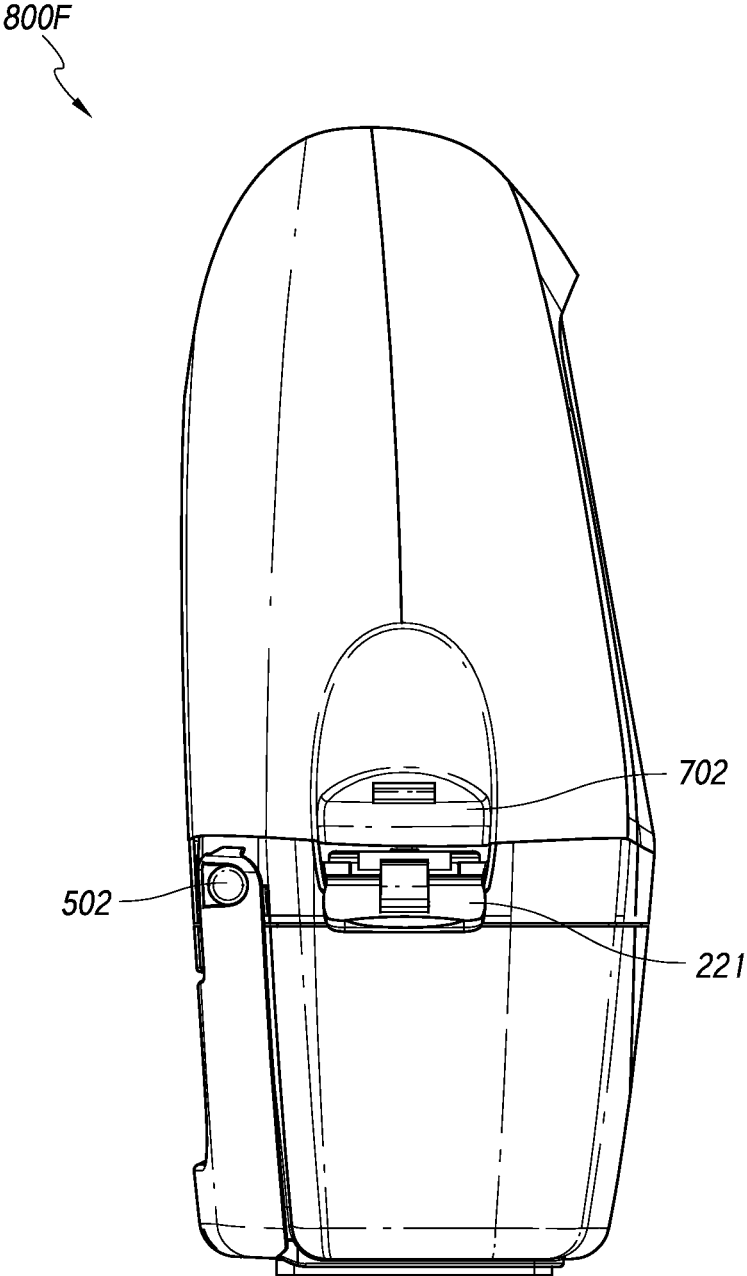

FIG. 8F

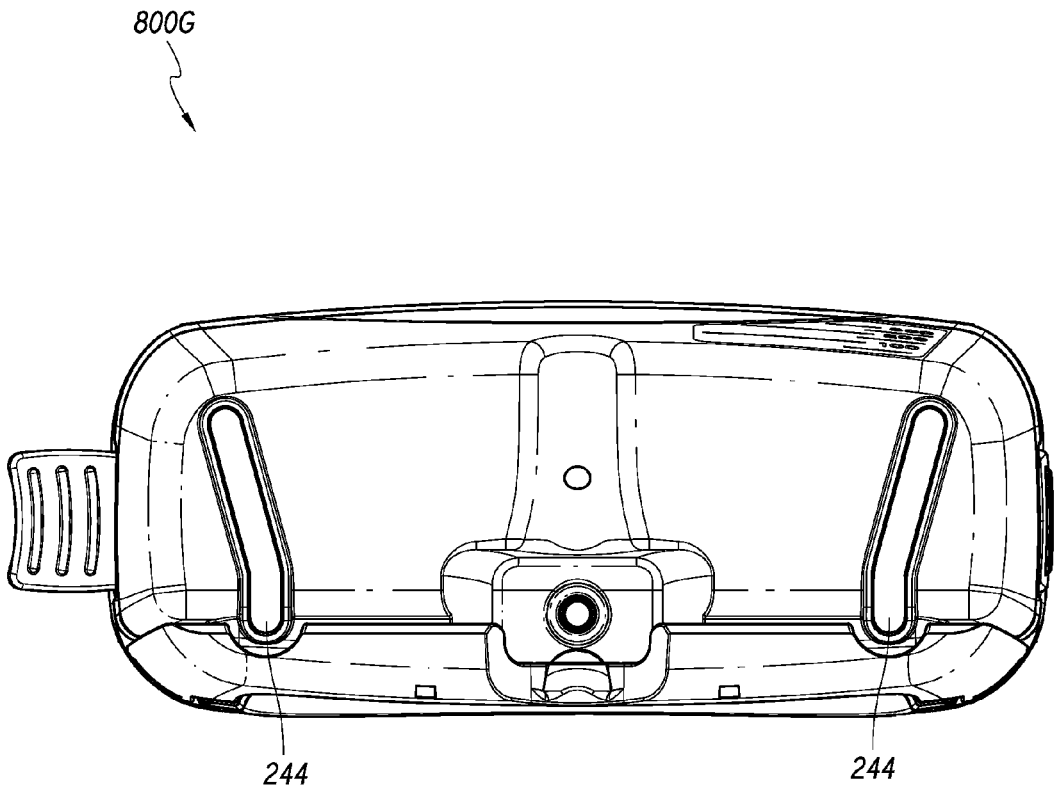

FIG. 8G

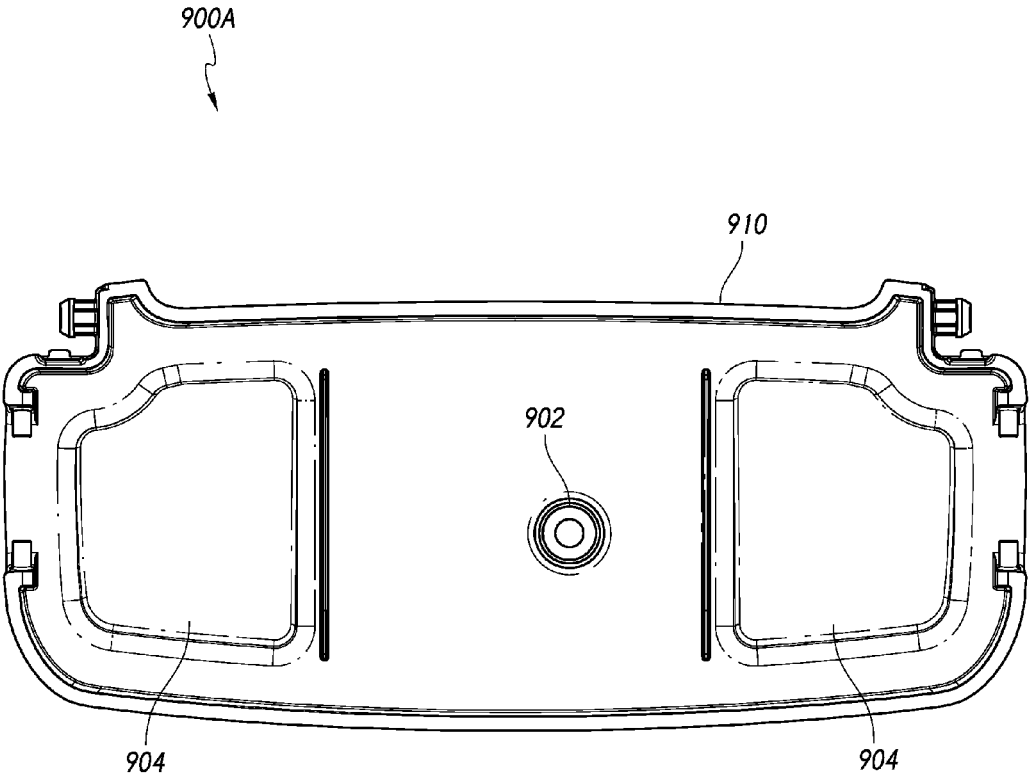
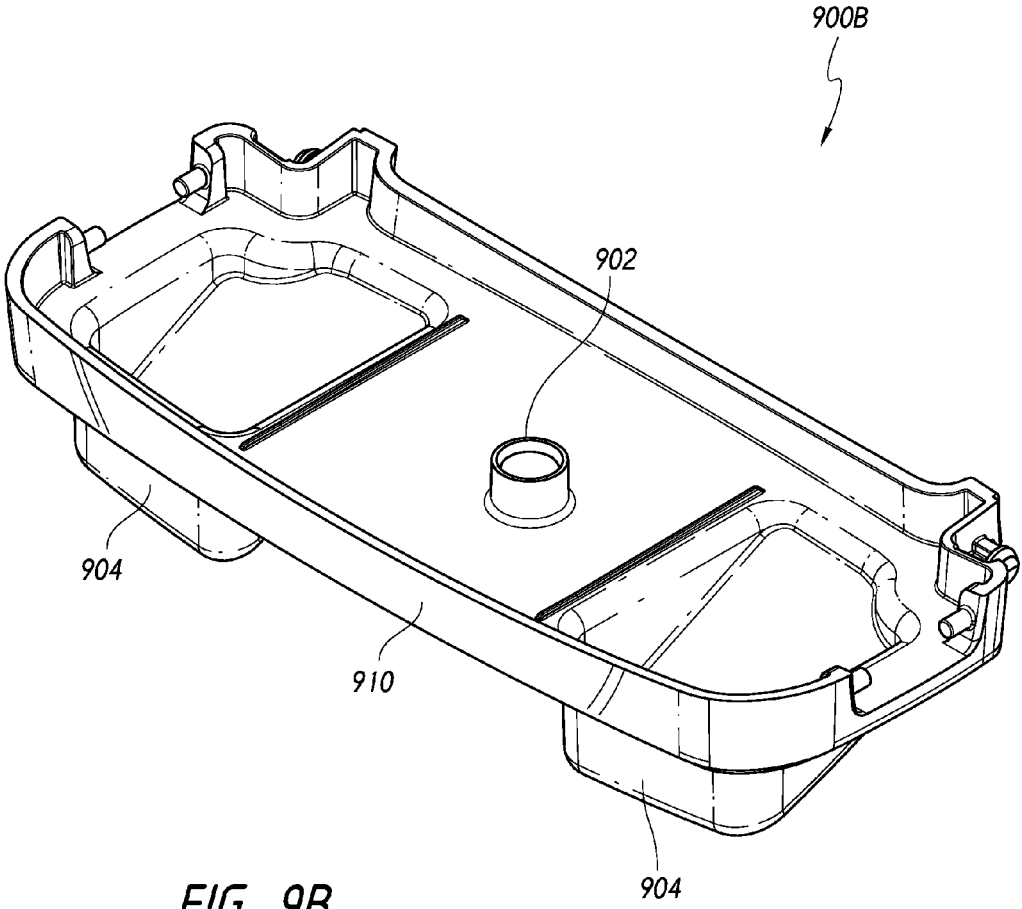

FIG. 9A



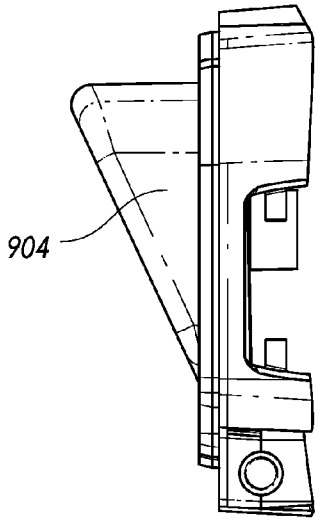
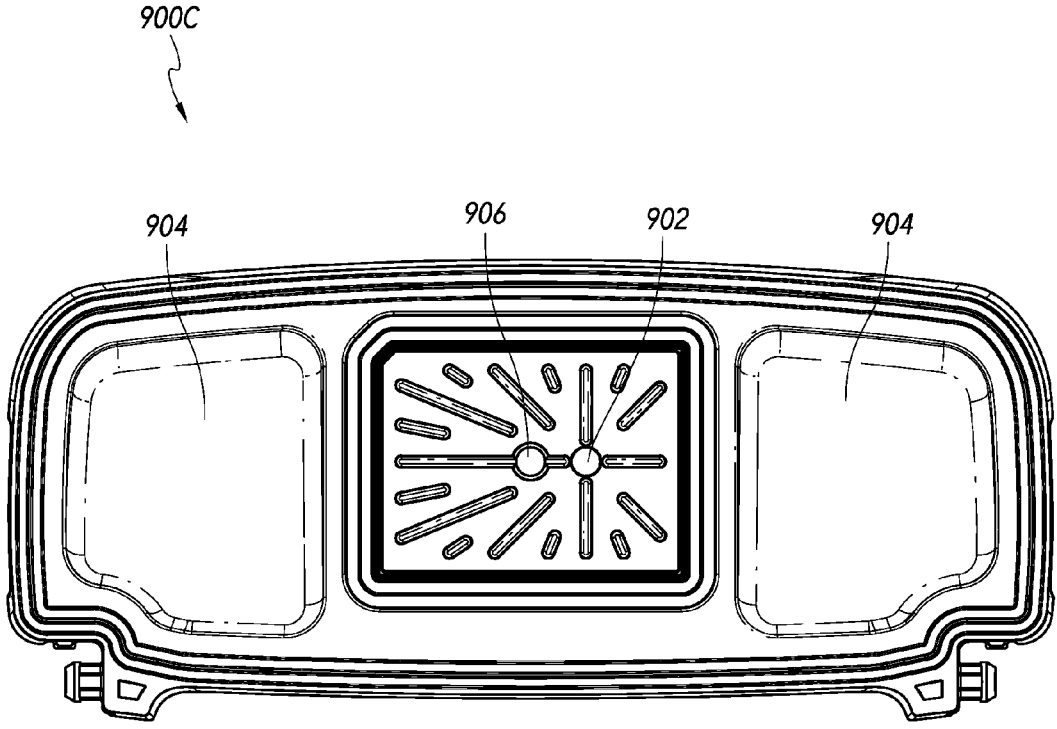

FIG. 9C

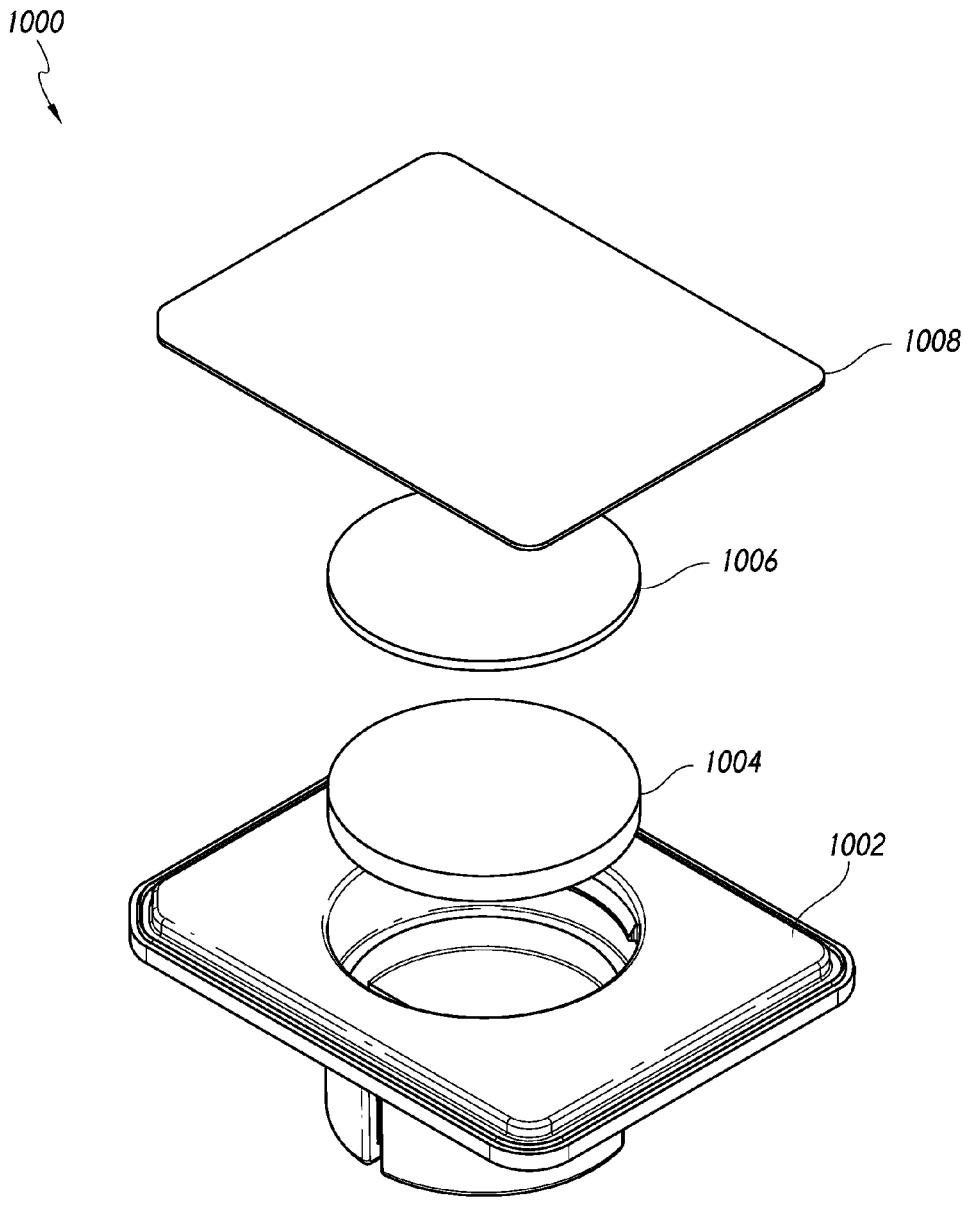

FIG. 10

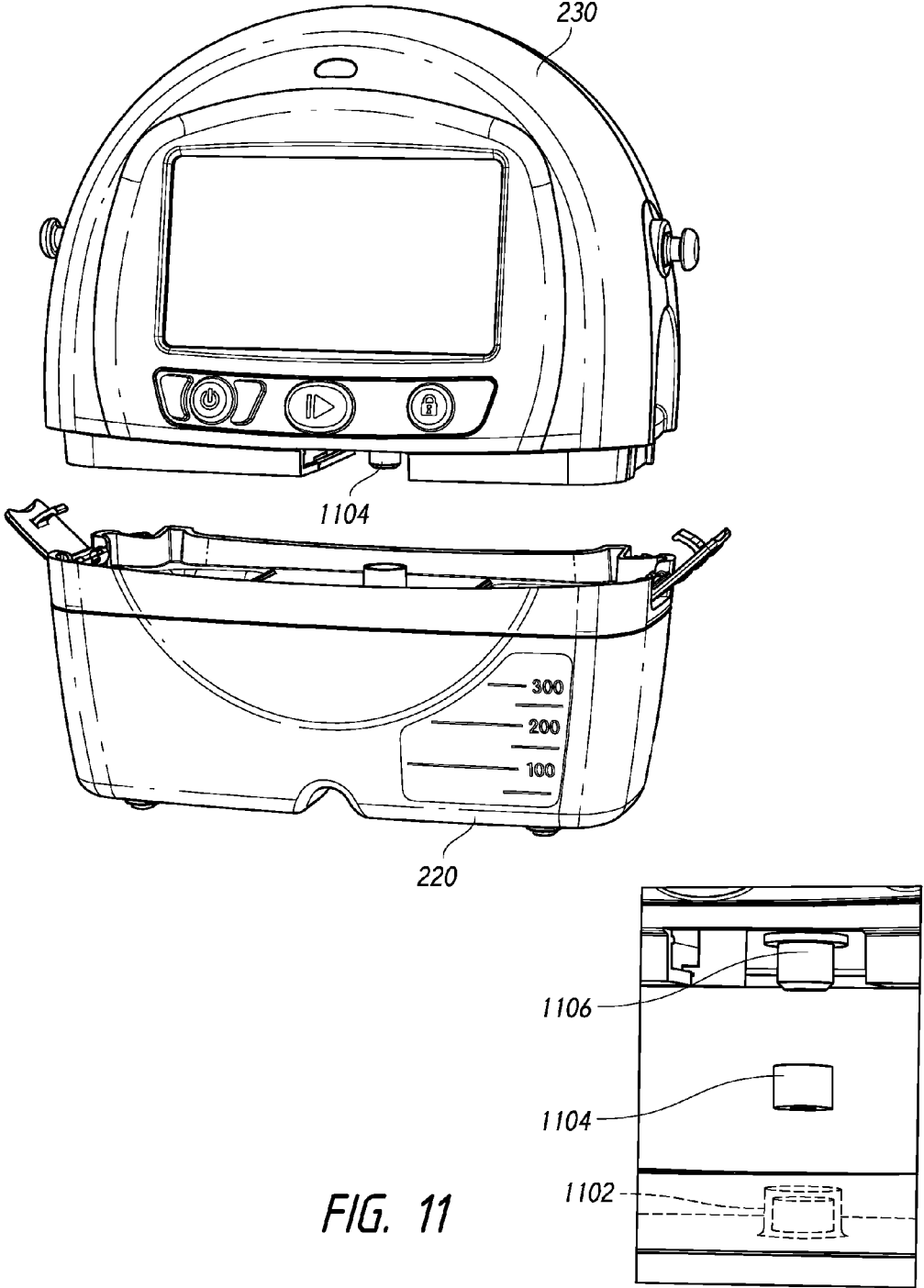

FIG. 11

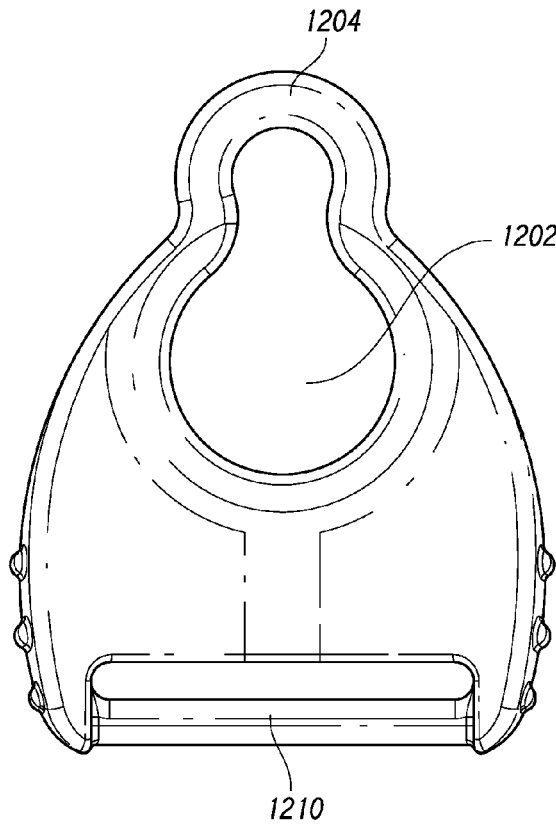
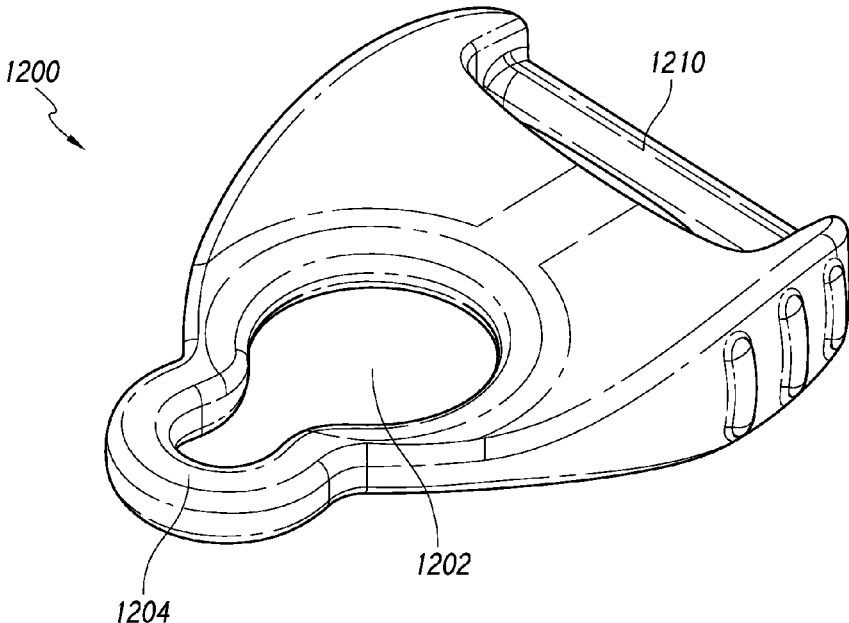

FIG. 12

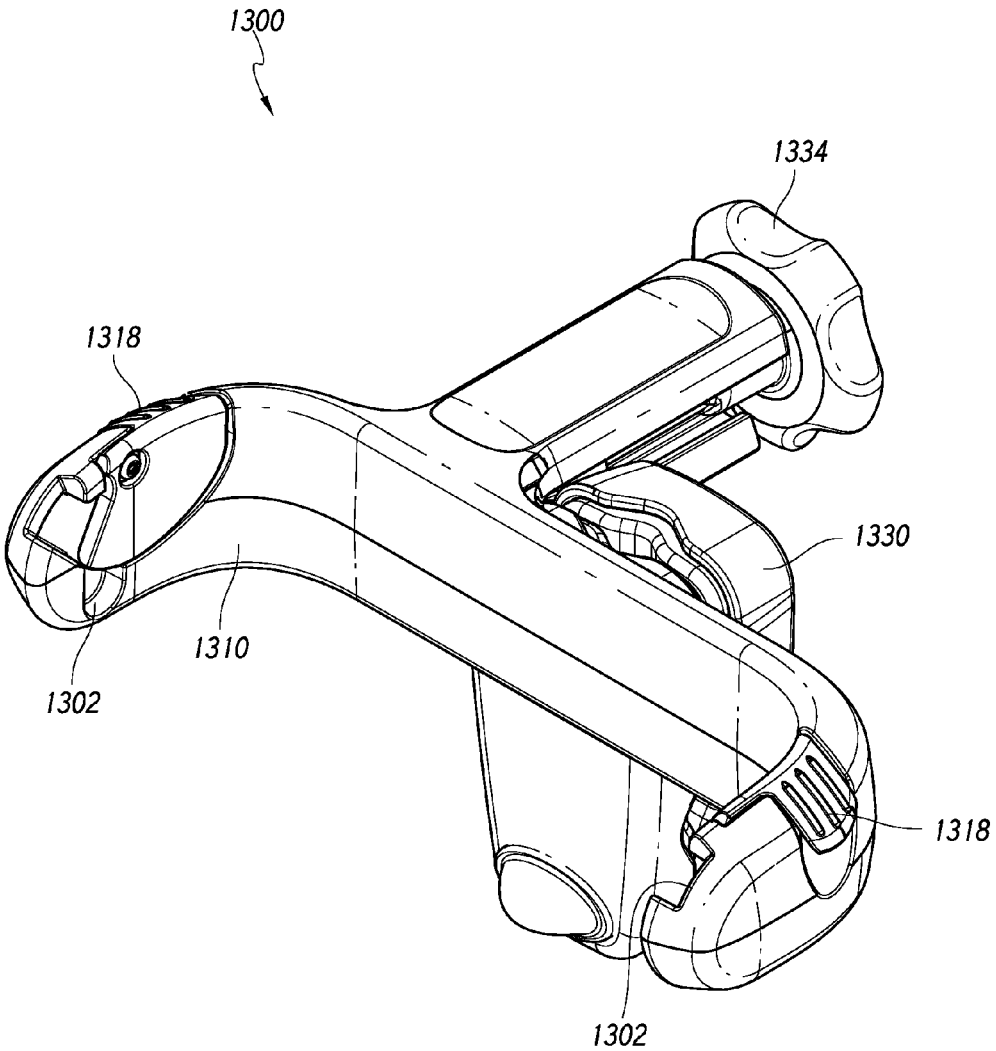
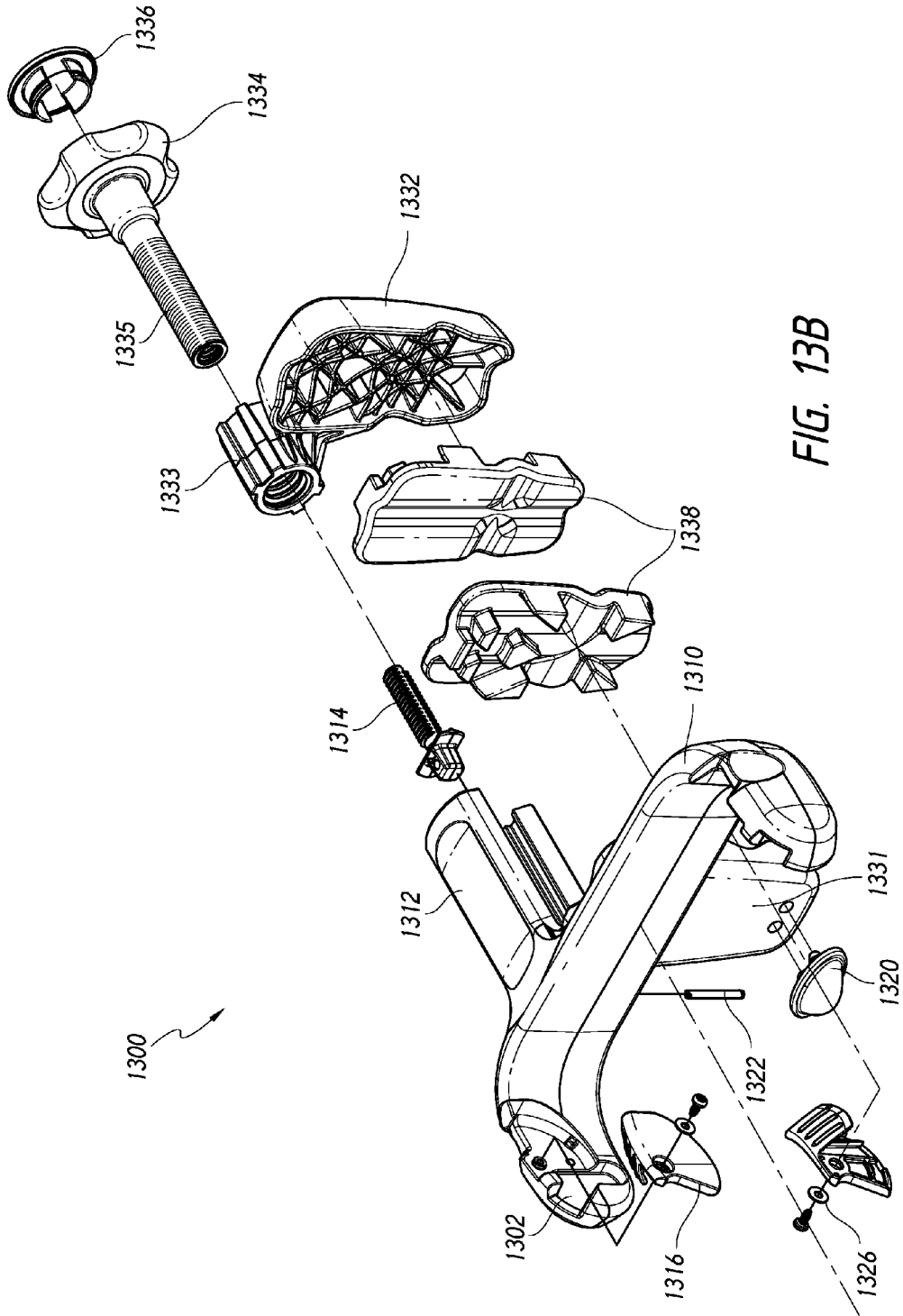

FIG. 13A



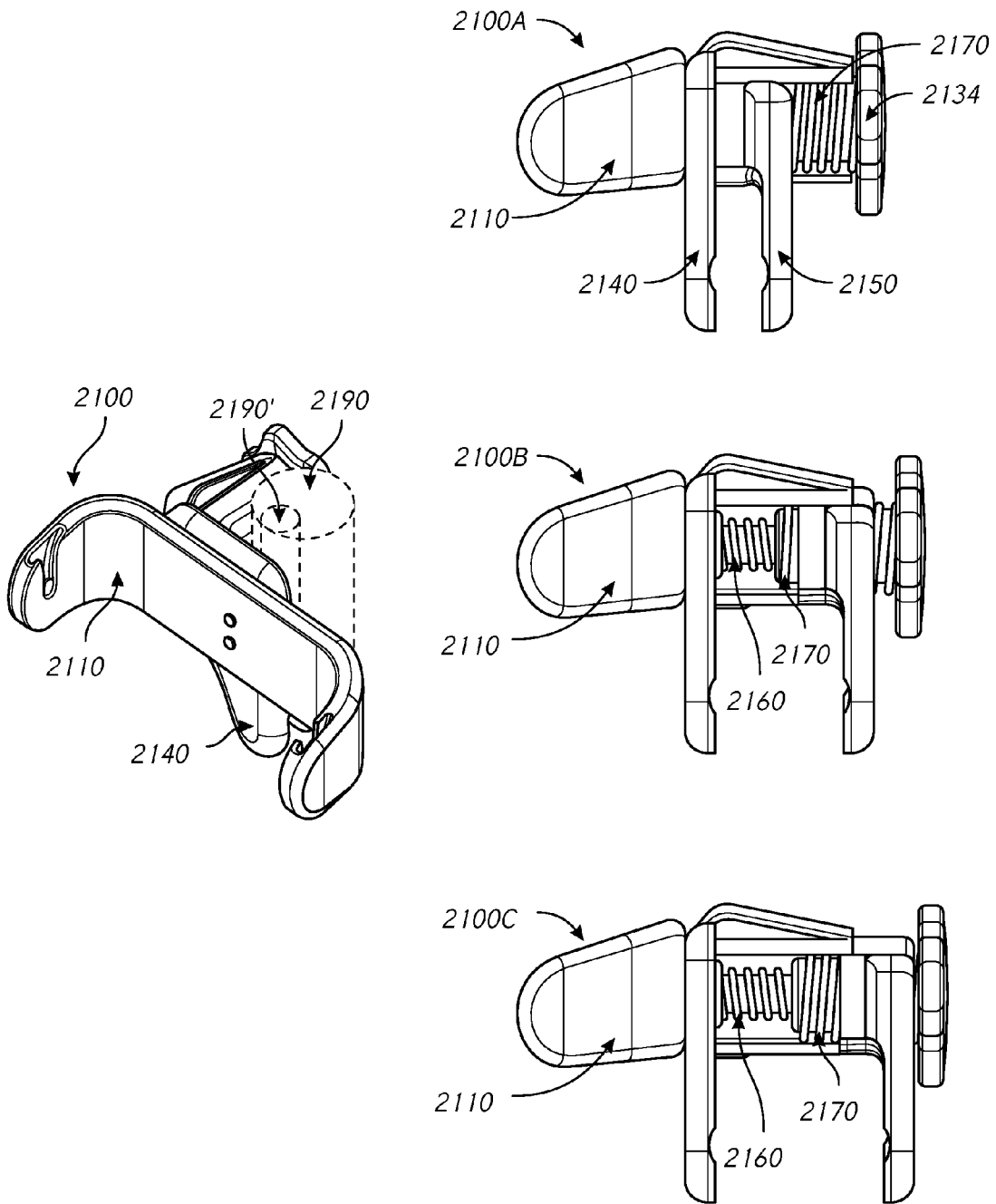

FIG. 13C

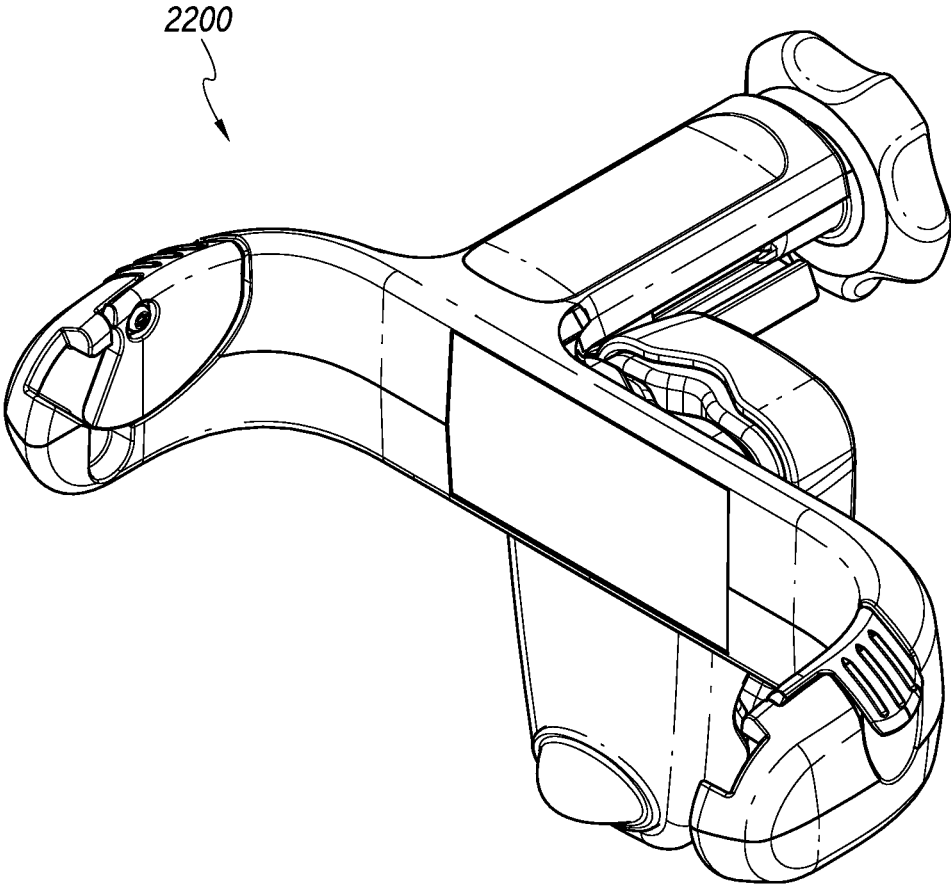

FIG. 13D

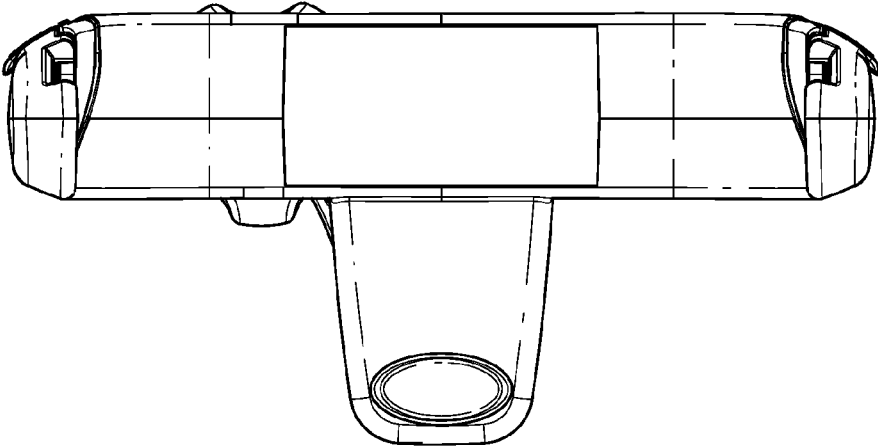

FIG. 13E

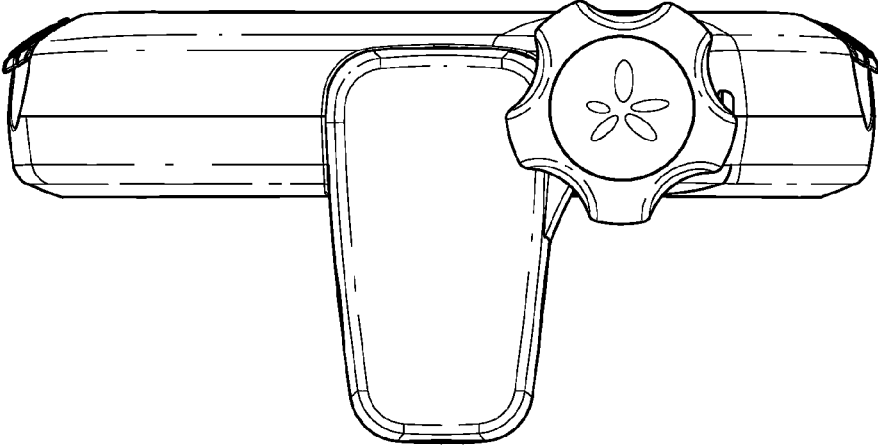

FIG. 13F

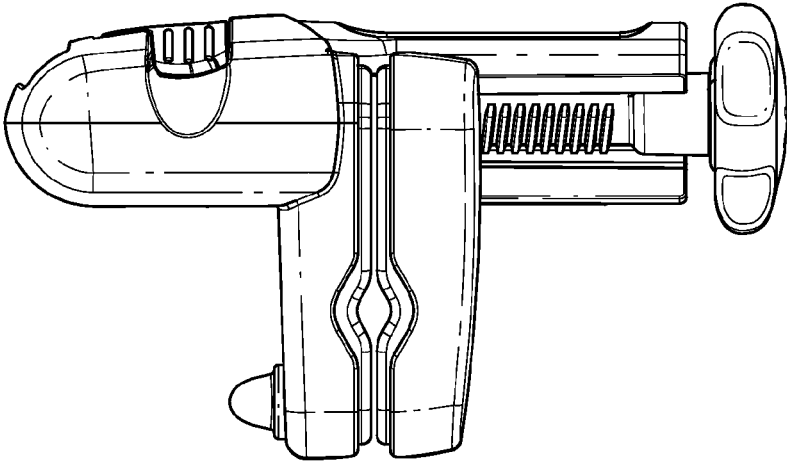

FIG. 13G

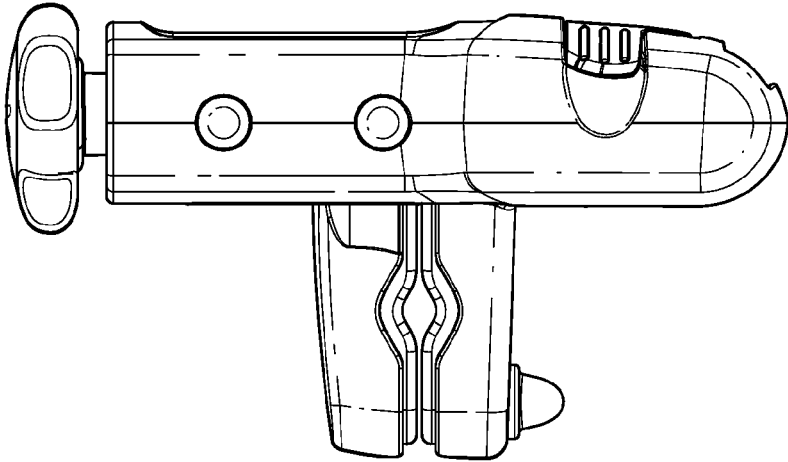

FIG. 13H

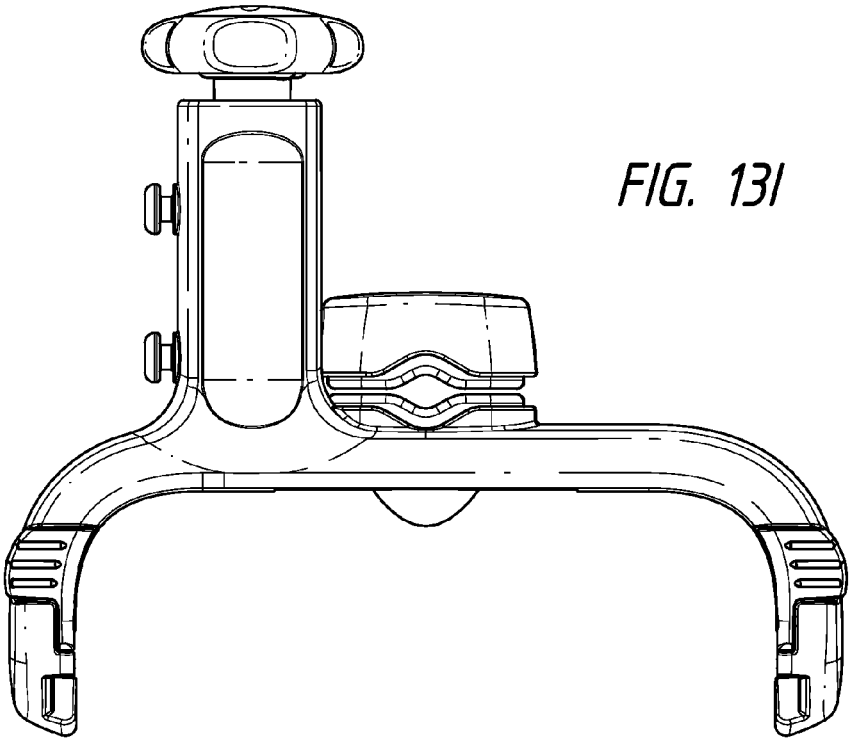

FIG. 13I

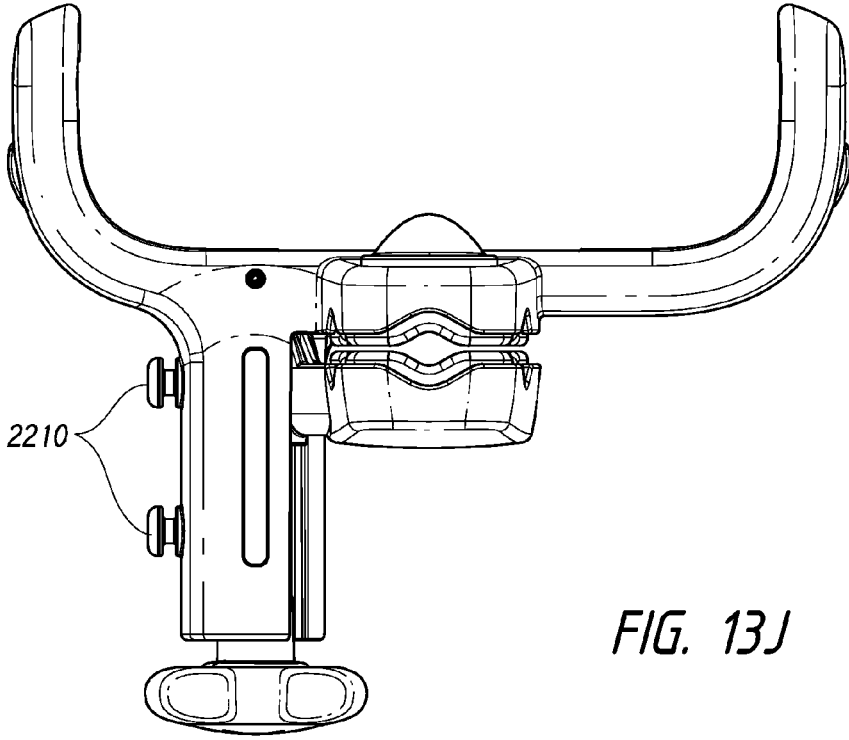

FIG. 13J

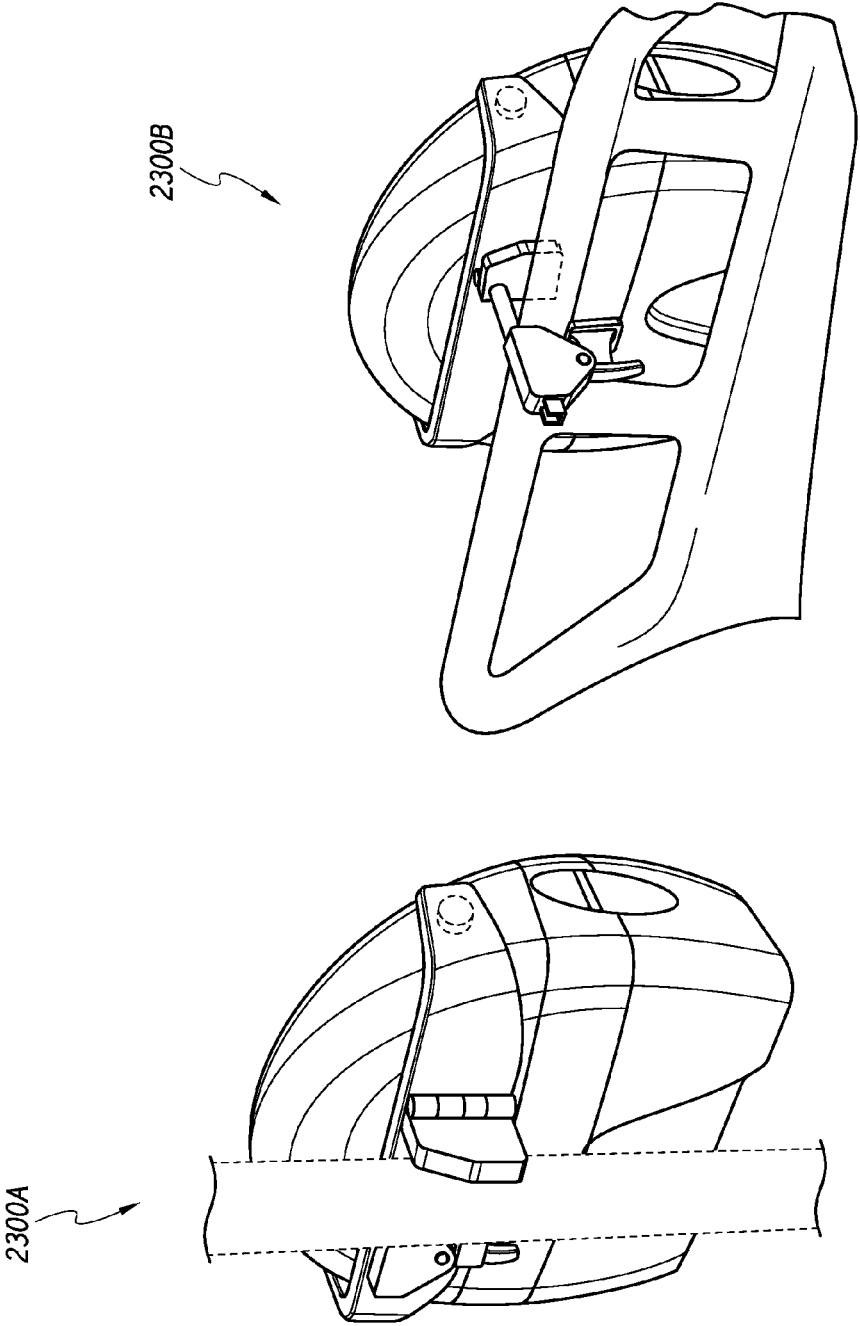

FIG. 13K

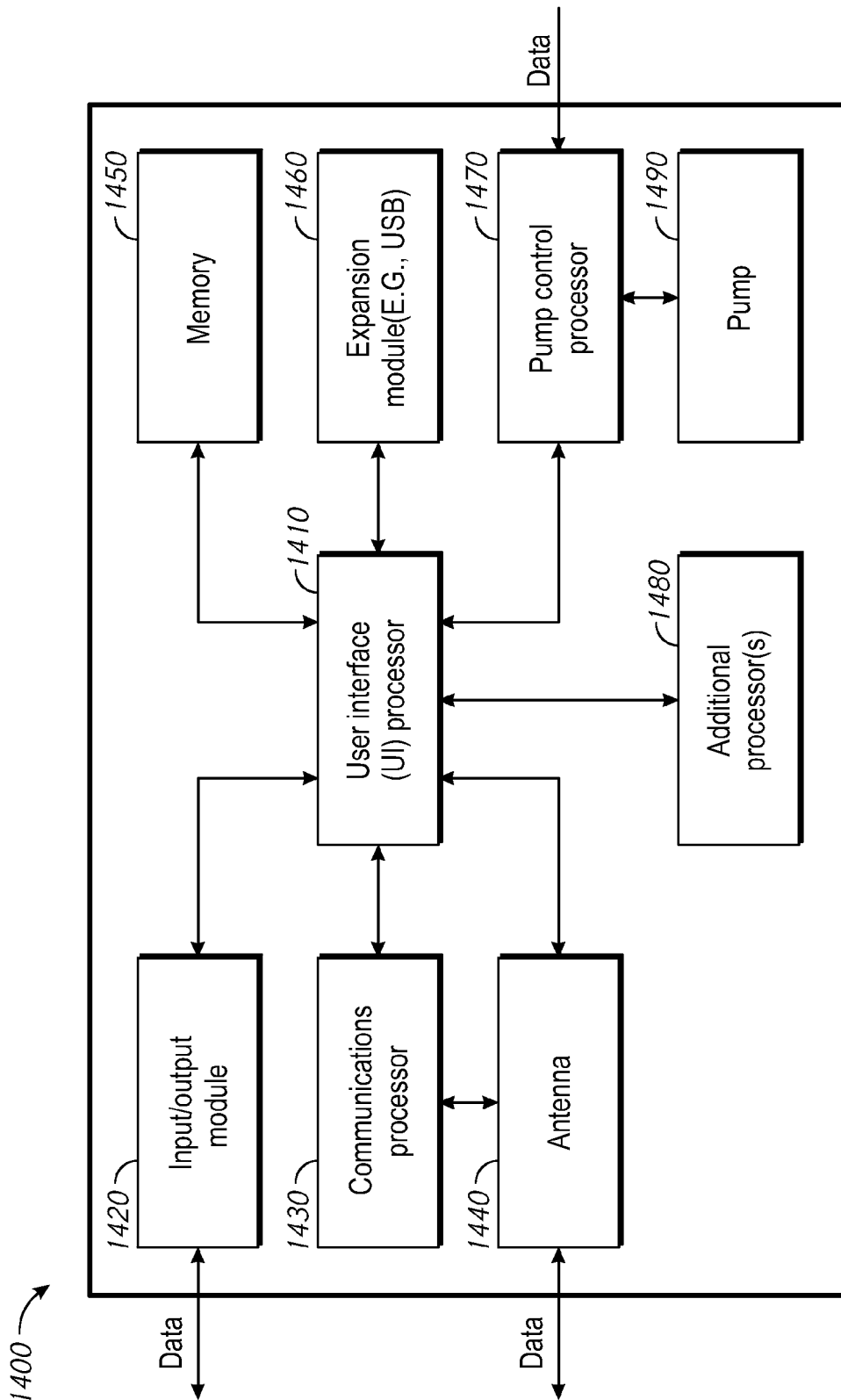

FIG. 14

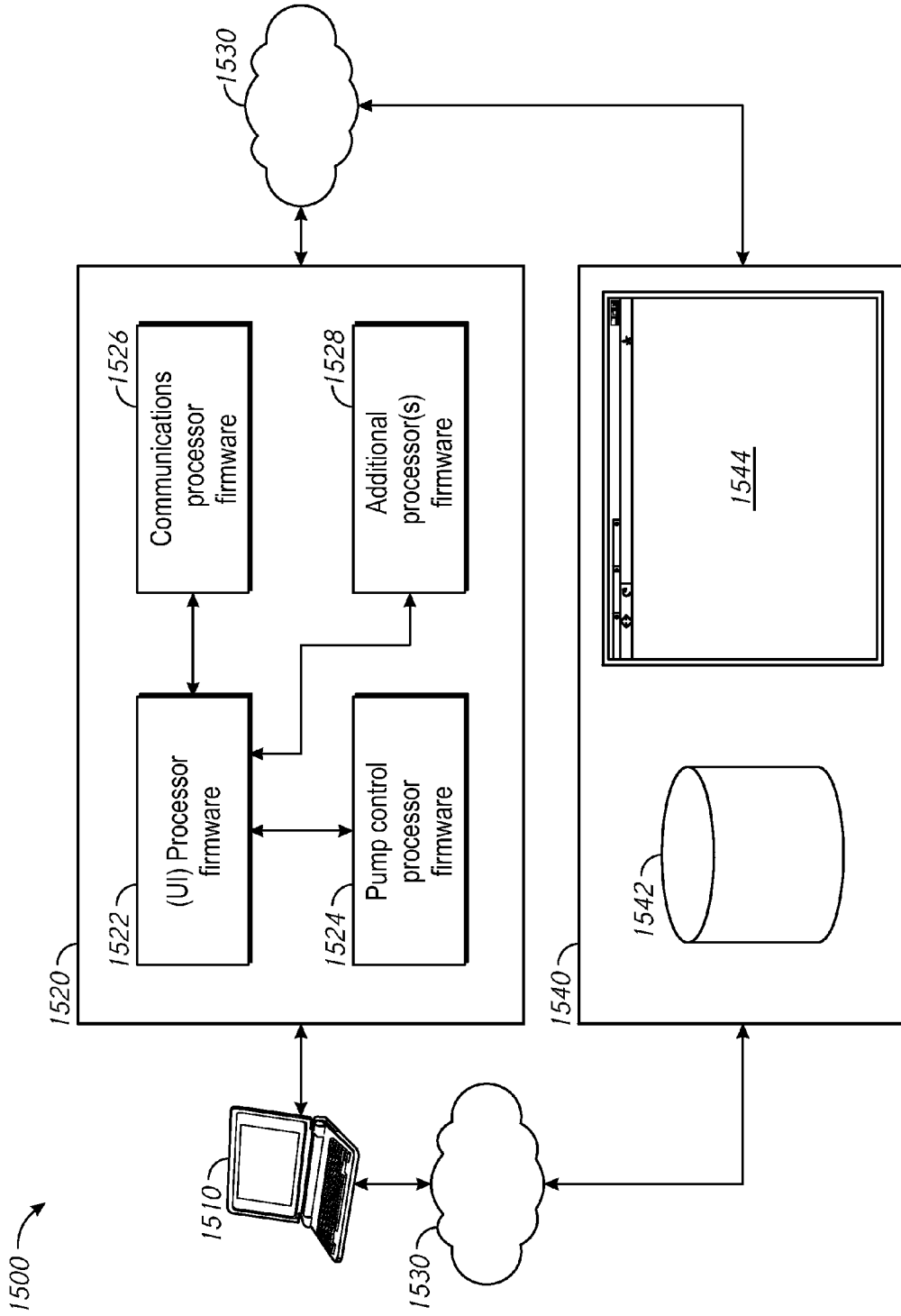

FIG. 15

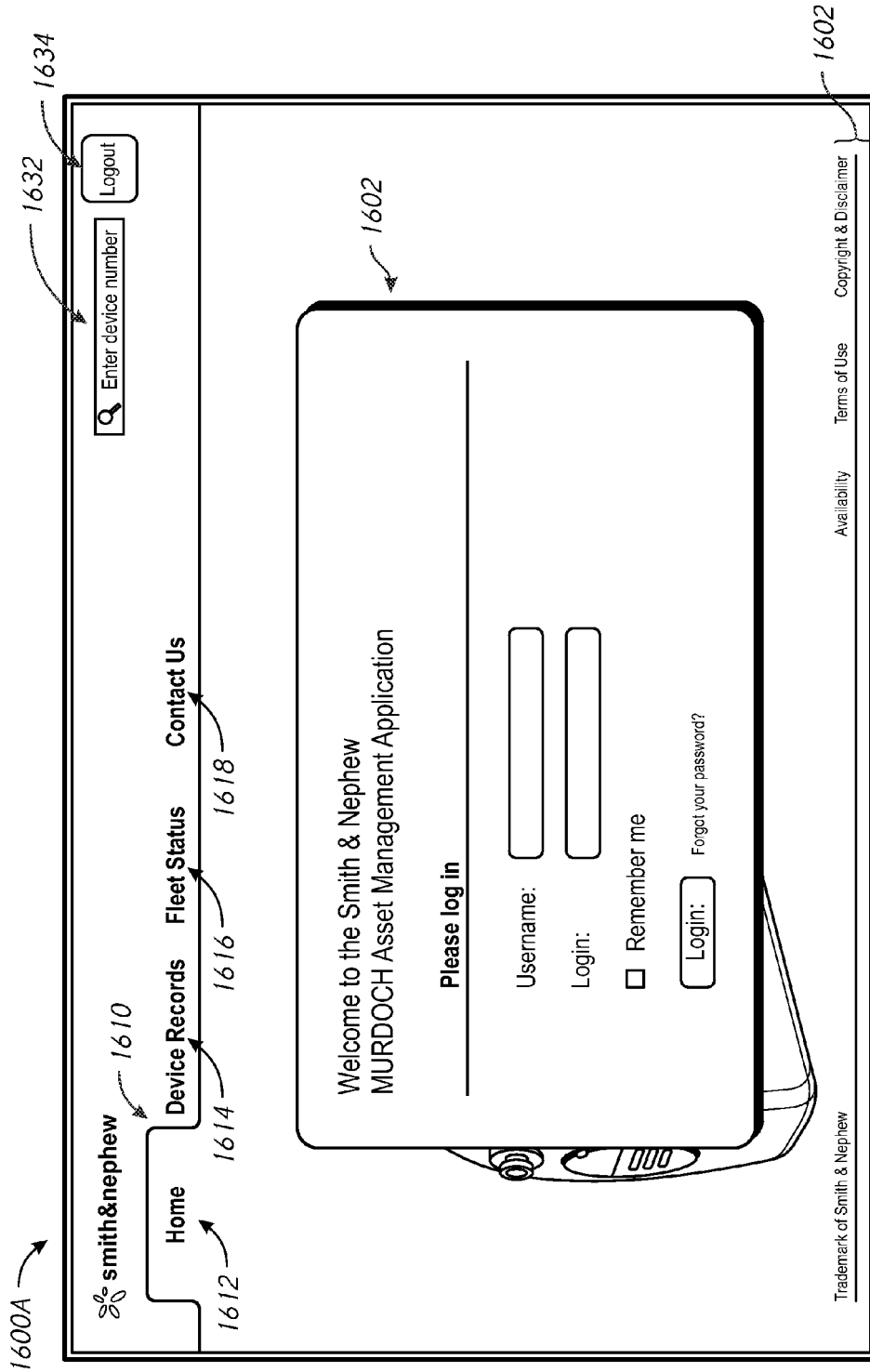

FIG. 16A

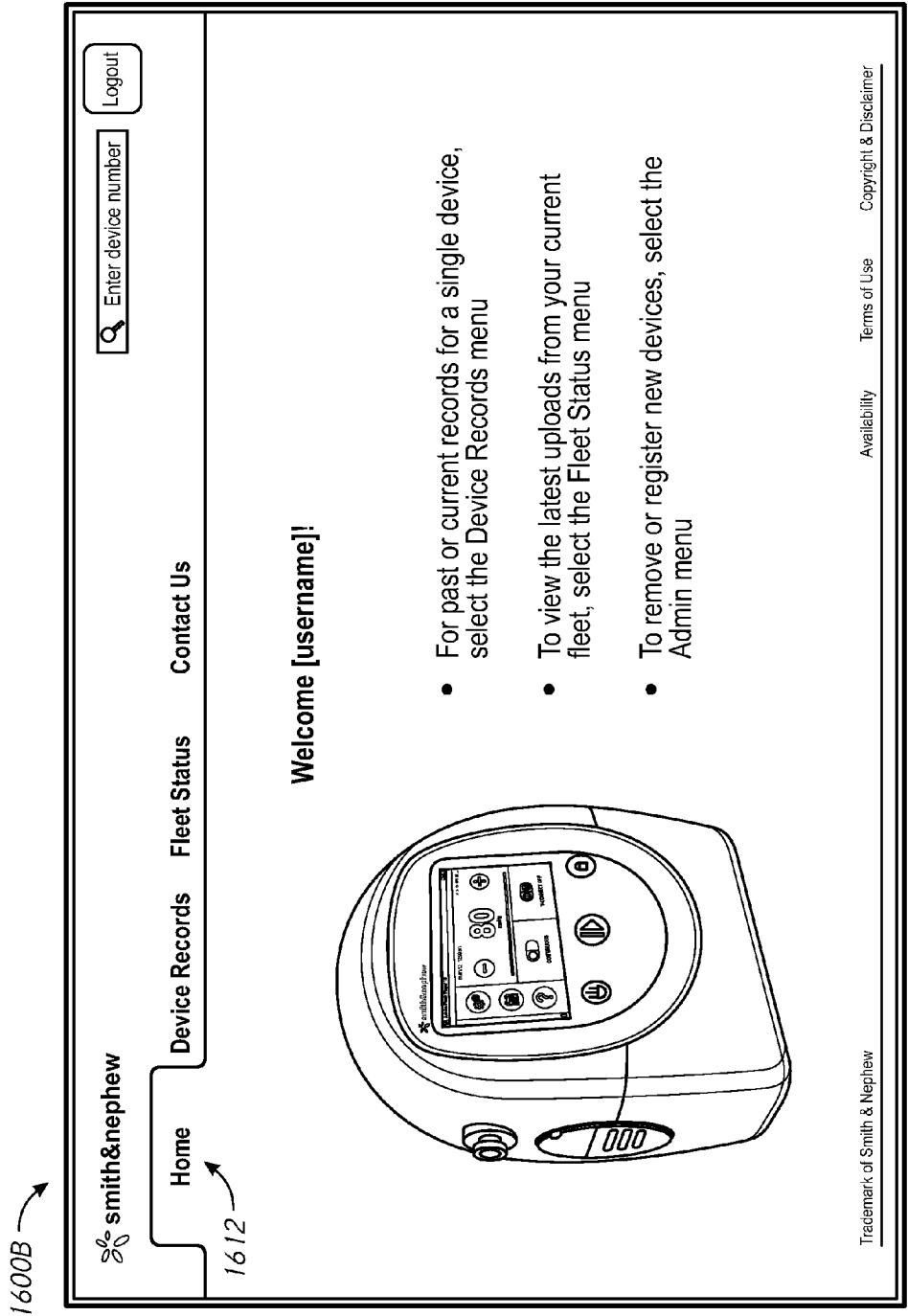

FIG. 16B

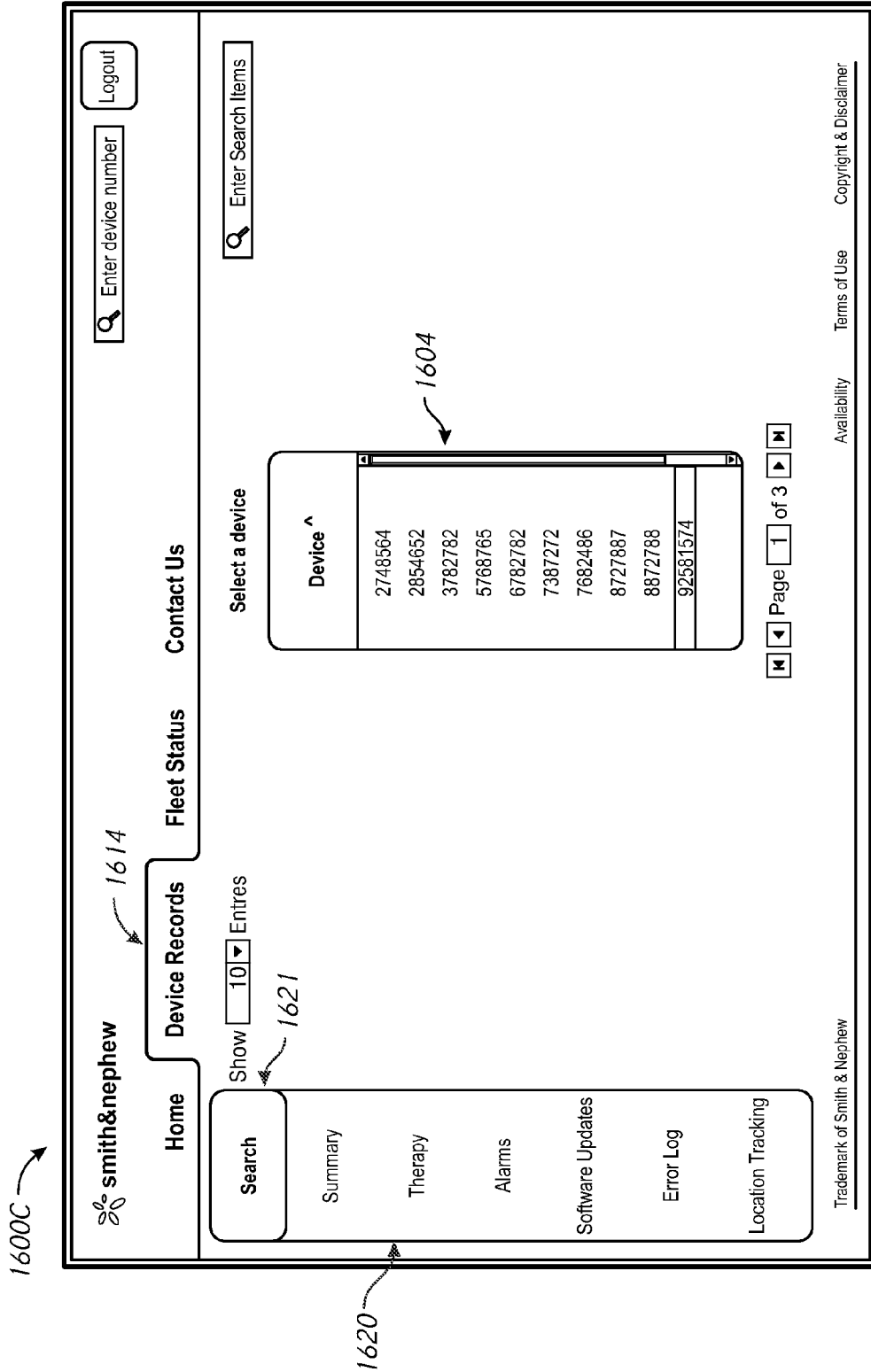

FIG. 16C

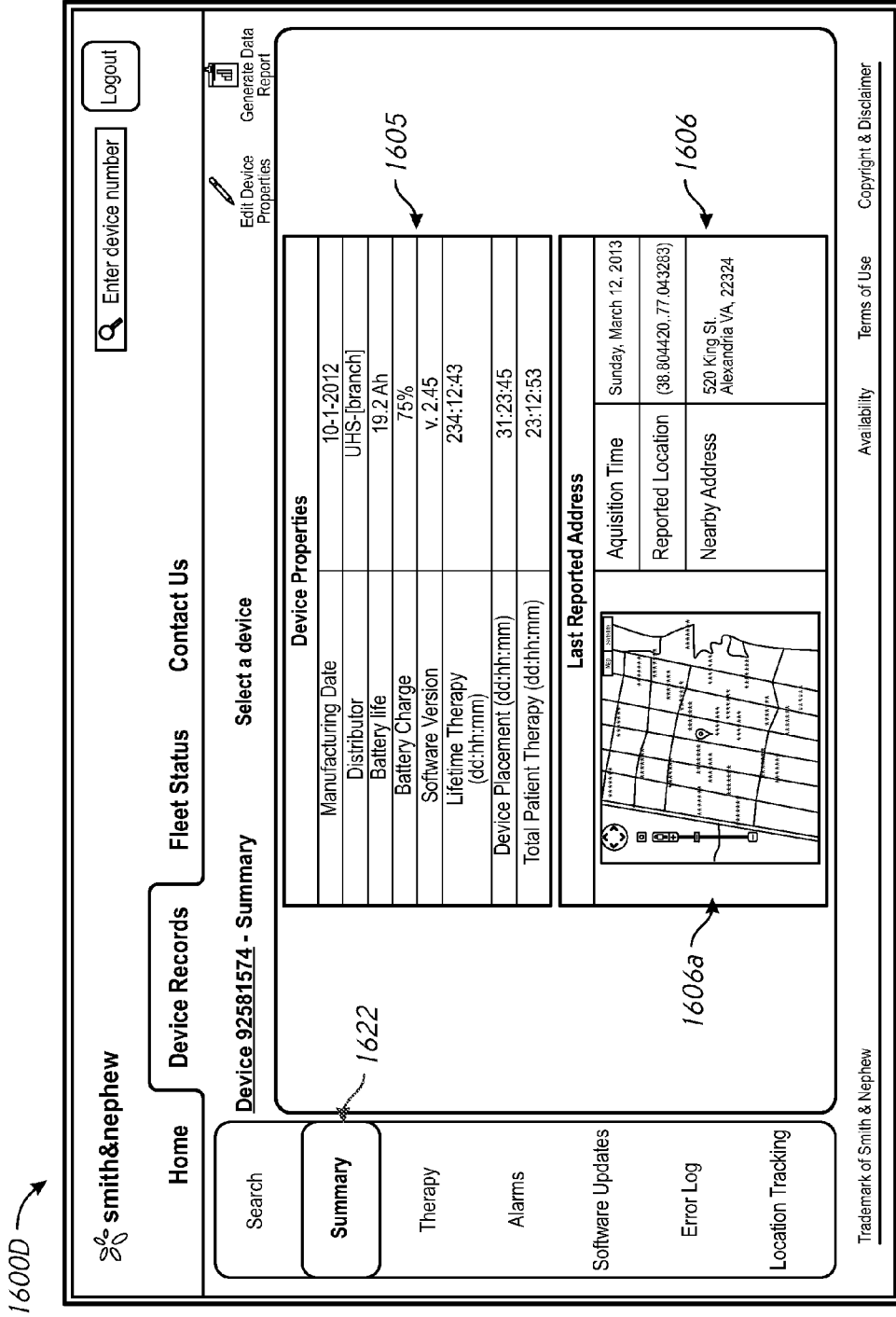

FIG. 16D

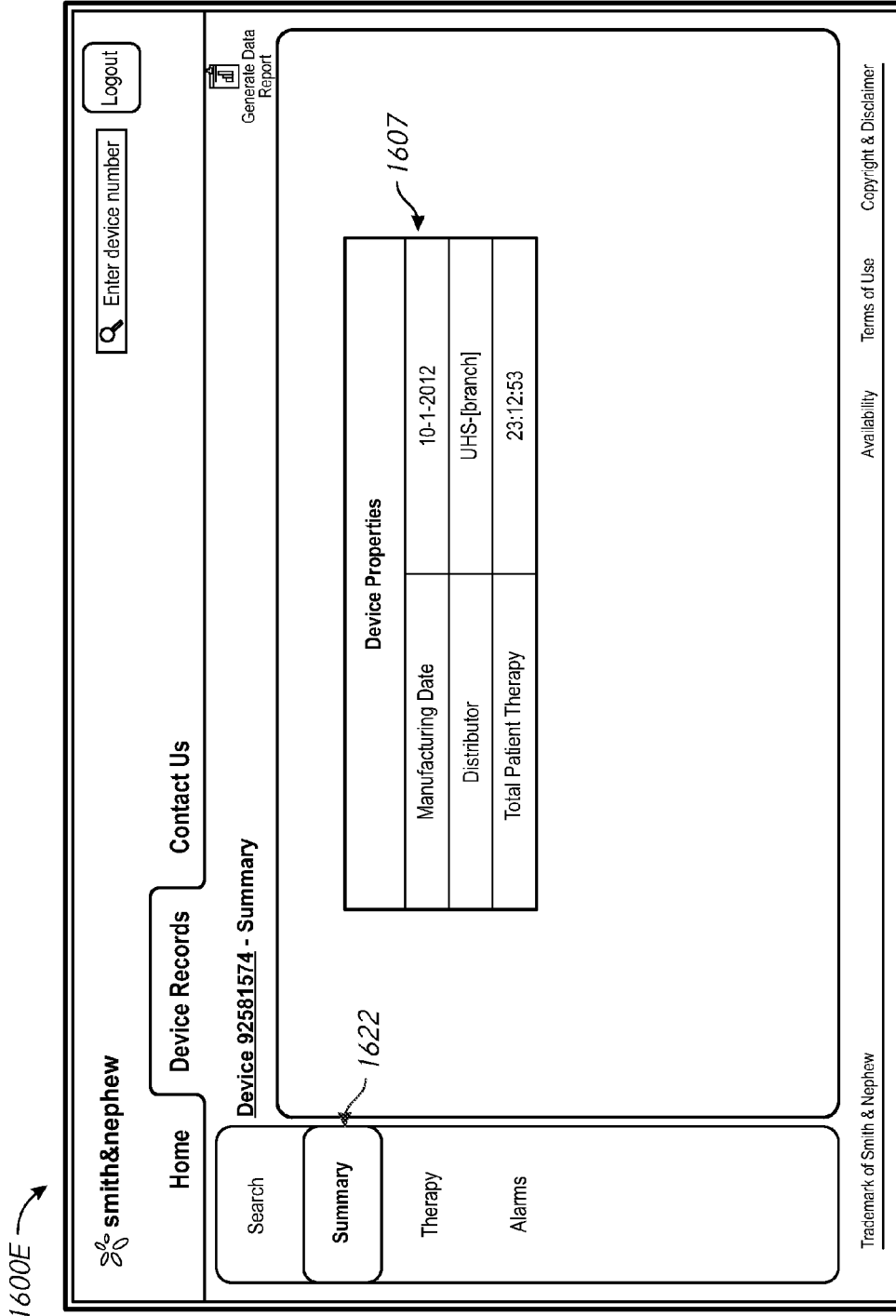

FIG. 16E

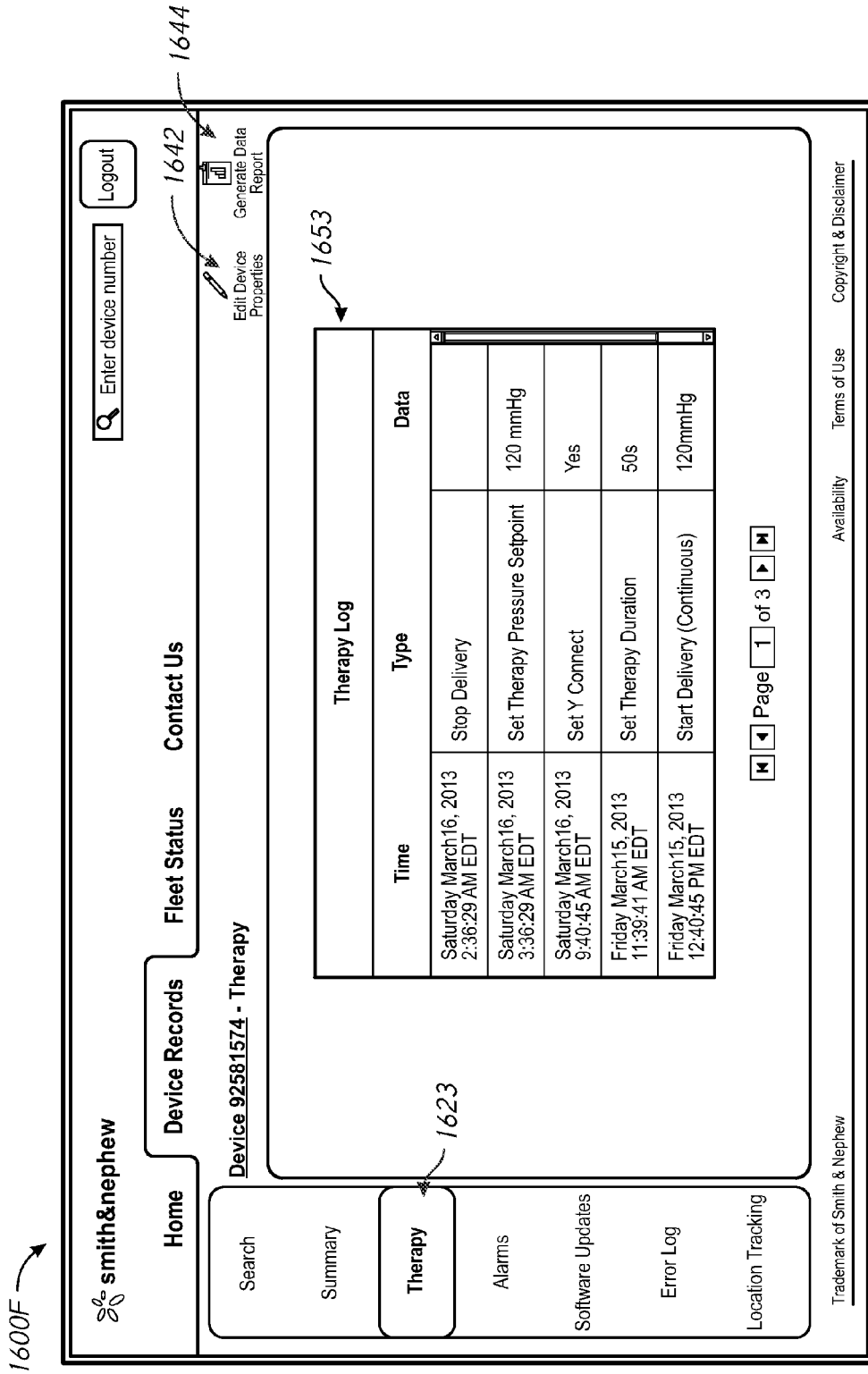

FIG. 16F

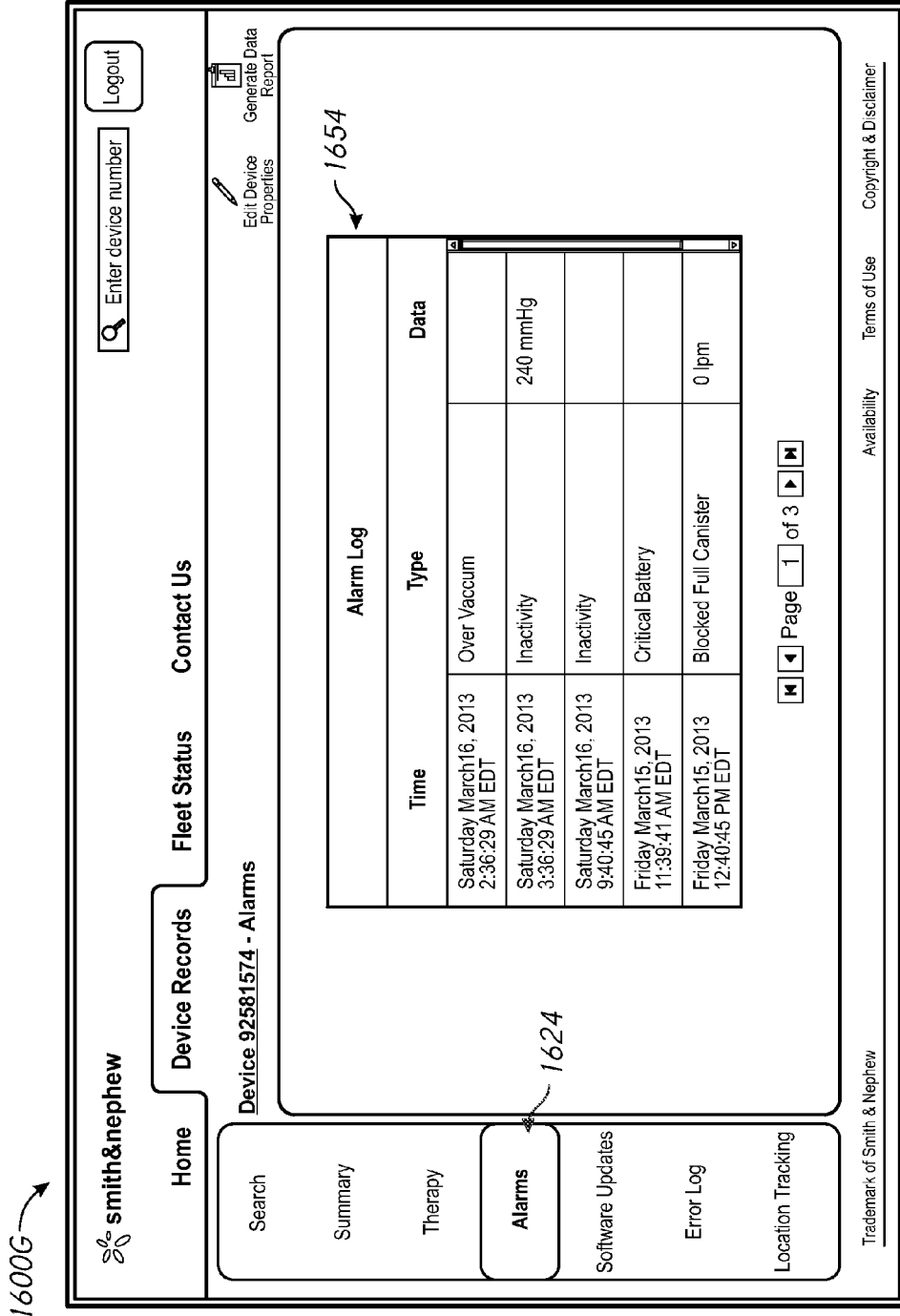

FIG. 16G

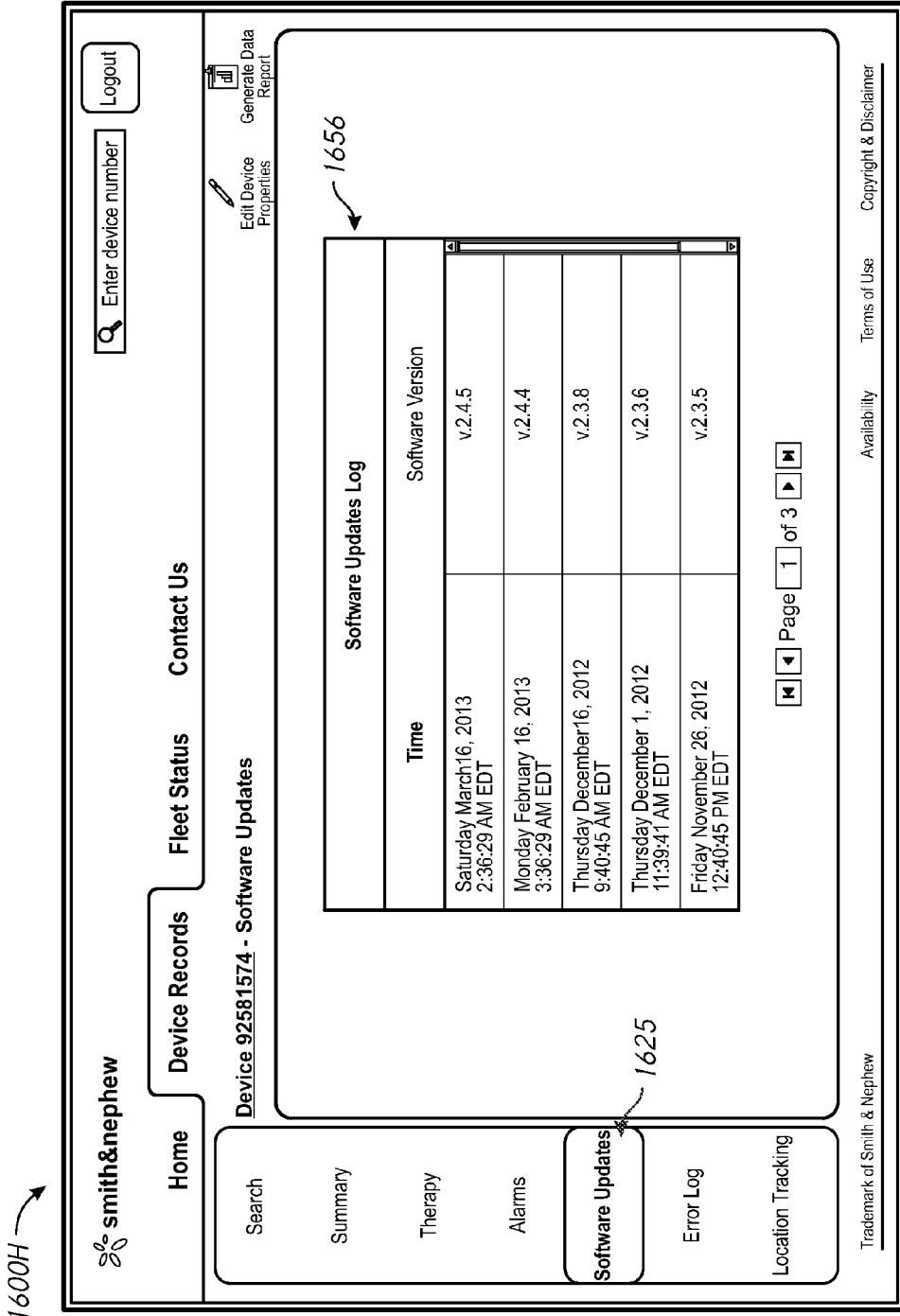

FIG. 16H

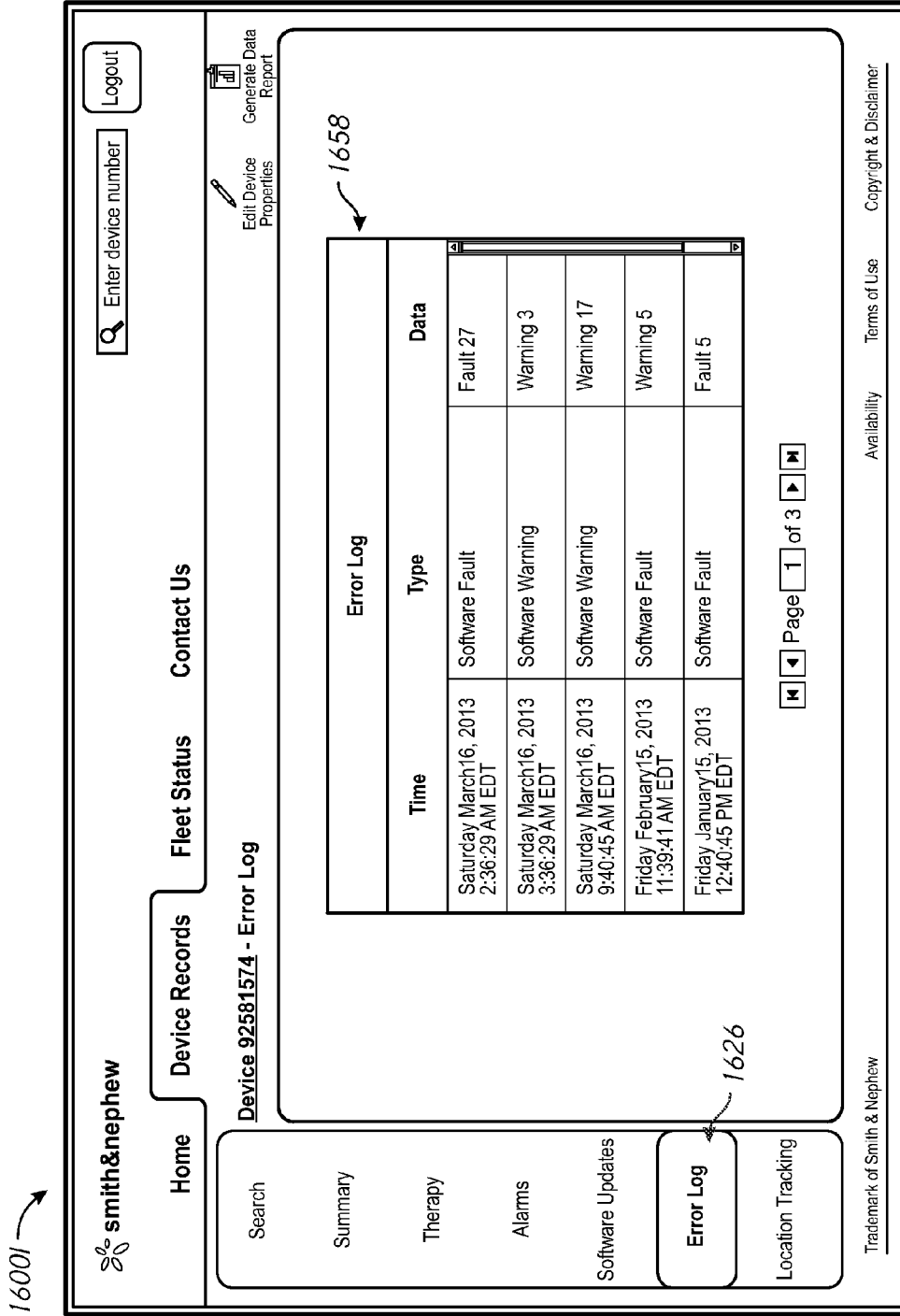

FIG. 161

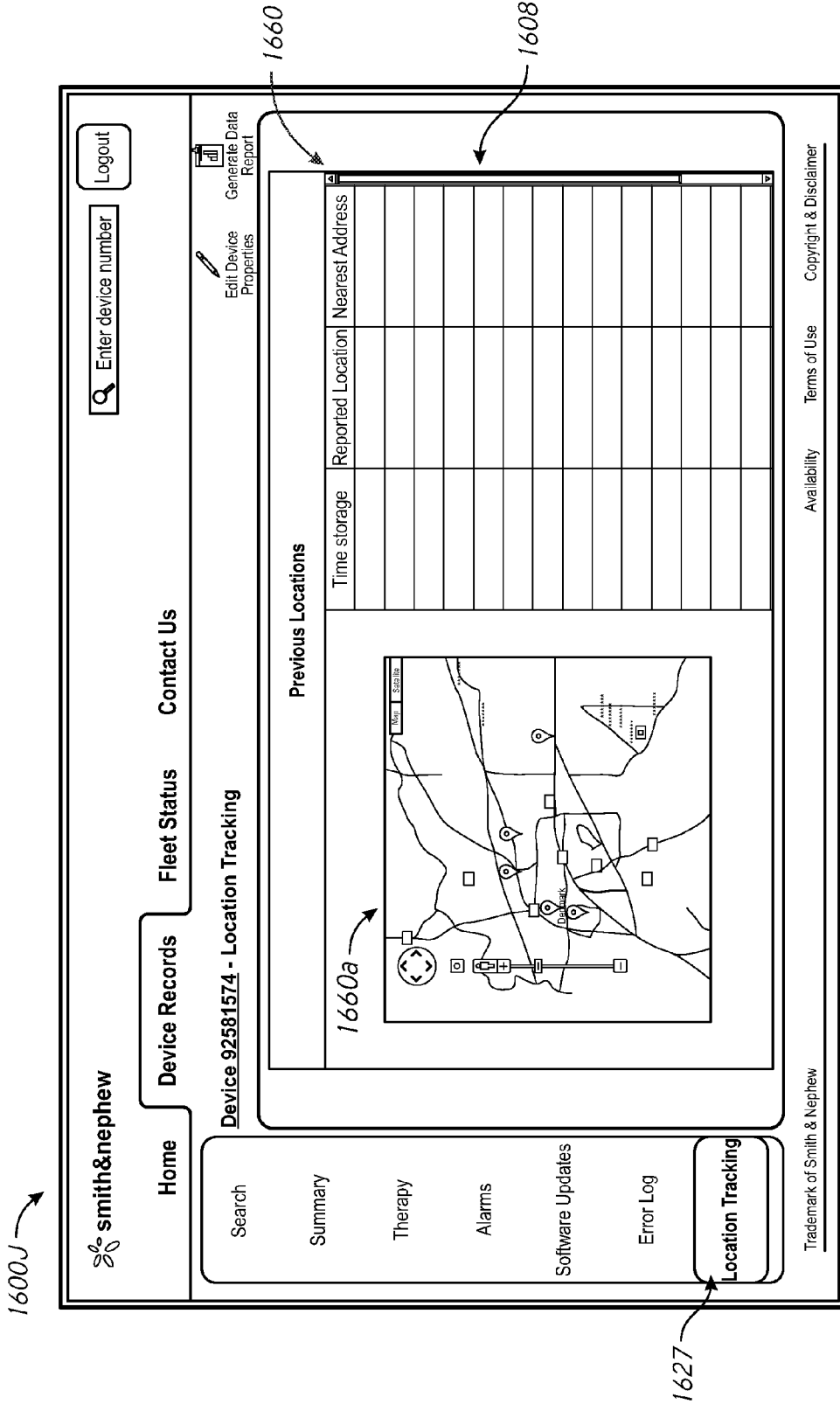

FIG. 16J

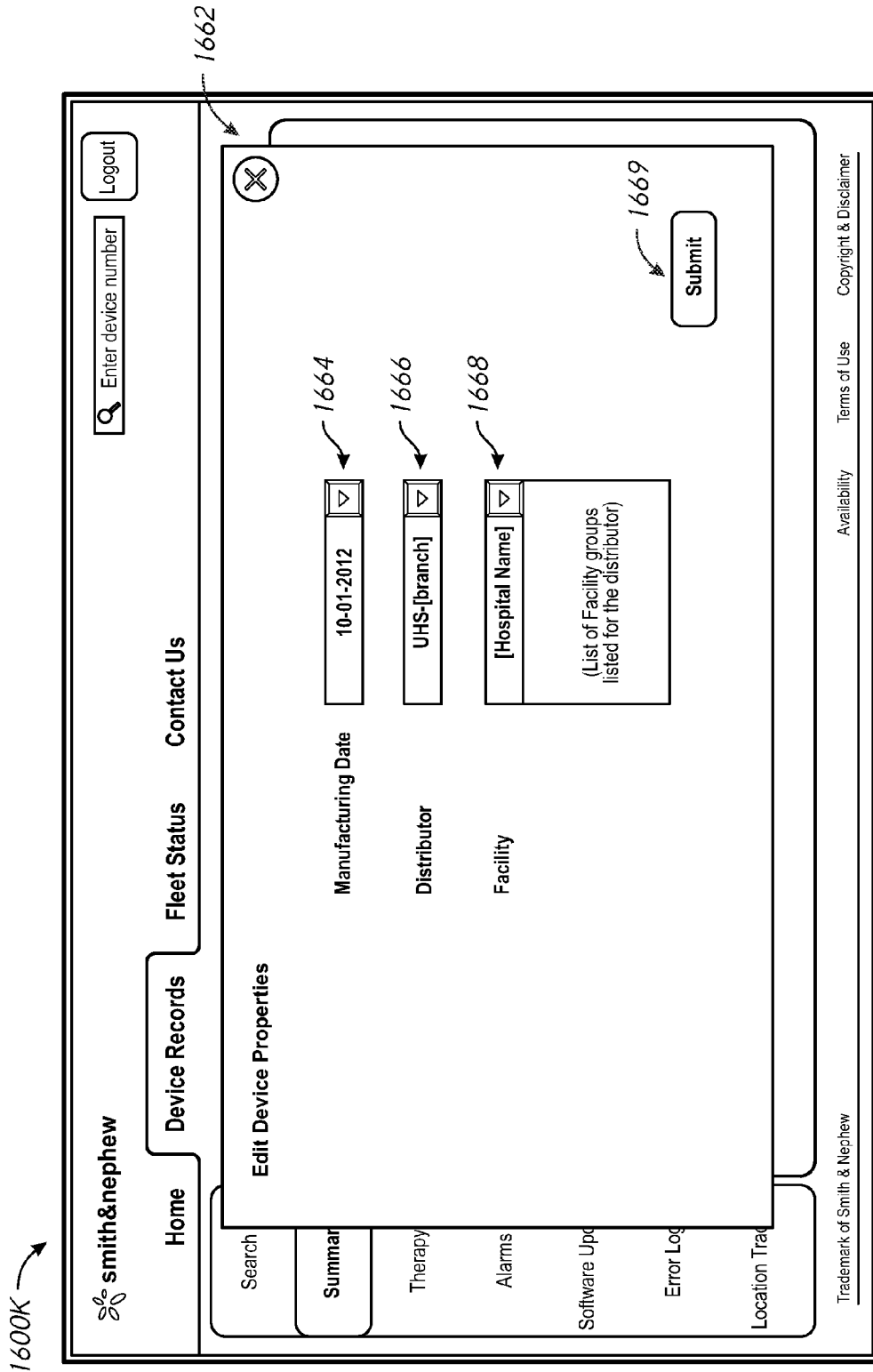

FIG. 16K

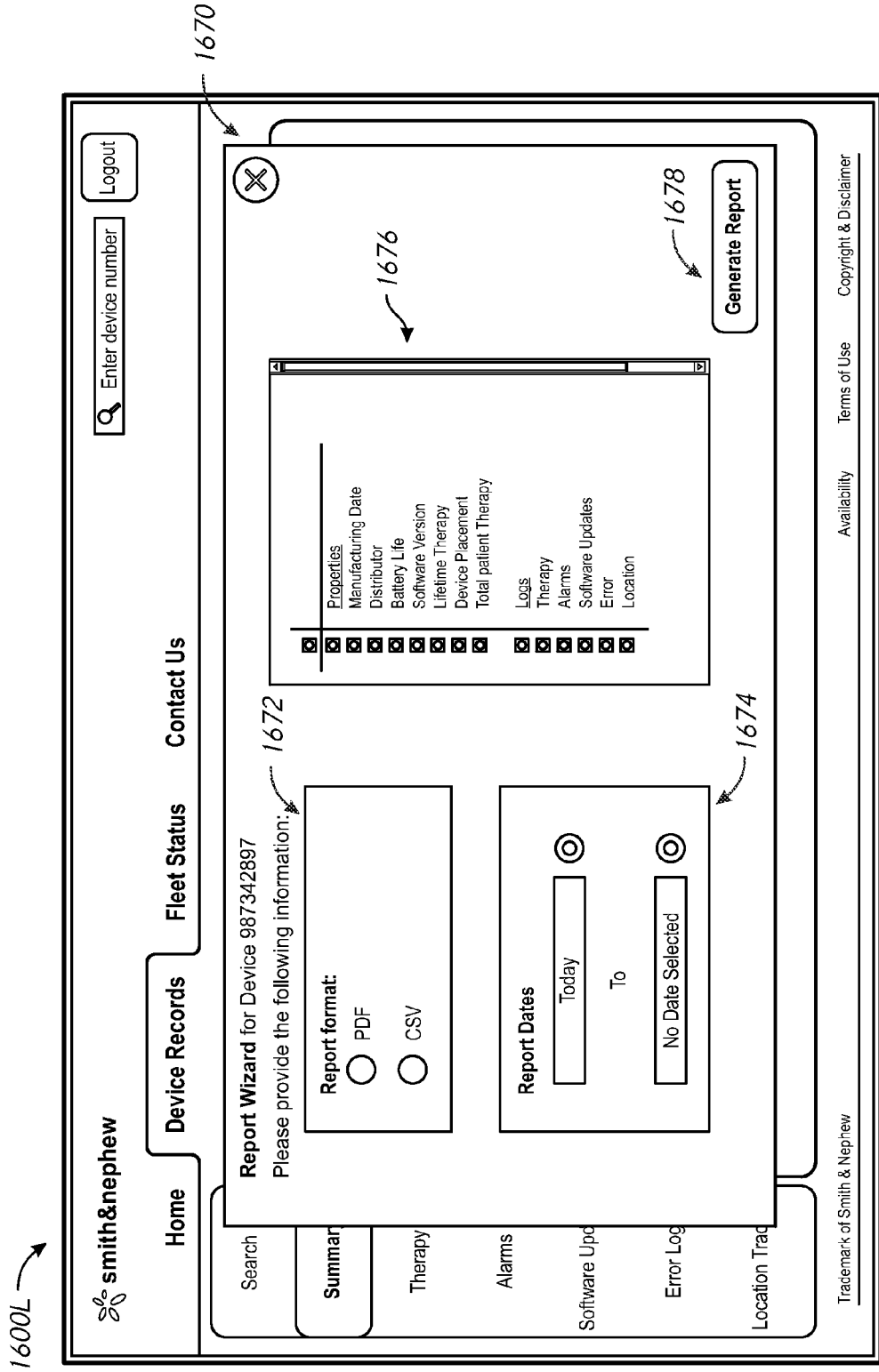
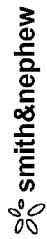

FIG. 16L

1600M  1616

Home Device Records **Fleet Status** Contact Us

Search 1621

Properties
Therapy
Battery
Software Version
Location

Select one or multiple devices from your current fleet to view

Show Entries

Select By 1682

1684

Device ^	Country ^	State ^	Zip ^	Distributor ^	Facility ^
<input type="checkbox"/> 2054052	United States	Virginia	22314	LHS (branch)	(Hospital Name)
<input checked="" type="checkbox"/> 5488263	United States	Indiana	46104	Aona (branch)	
<input type="checkbox"/> 70267512	United States	Indiana	46140	LHS (branch)	(Hospital Name)
<input type="checkbox"/> 67380952	United States	Virginia	22314	Aona (branch)	(Hospital Name)
<input checked="" type="checkbox"/> 92501574	United States	Virginia	22305	LHS (branch)	(Hospital Name)
<input type="checkbox"/> 2054052	United States	Virginia	22314	LHS (branch)	(Hospital Name)
<input type="checkbox"/> 5488263	United States	Indiana	46104	Aona (branch)	
<input checked="" type="checkbox"/> 70267512	United States	Indiana	46143	LHS (branch)	(Hospital Name)
<input type="checkbox"/> 67380952	United States	Virginia	22314	Aona (branch)	
<input type="checkbox"/> 92501574	United States	Virginia	22305	LHS (branch)	(Hospital Name)

1686

Page 1 of 3

Display Data

Availability Terms of Use Copyright & Disclaimer

1600M

FIG. 16M

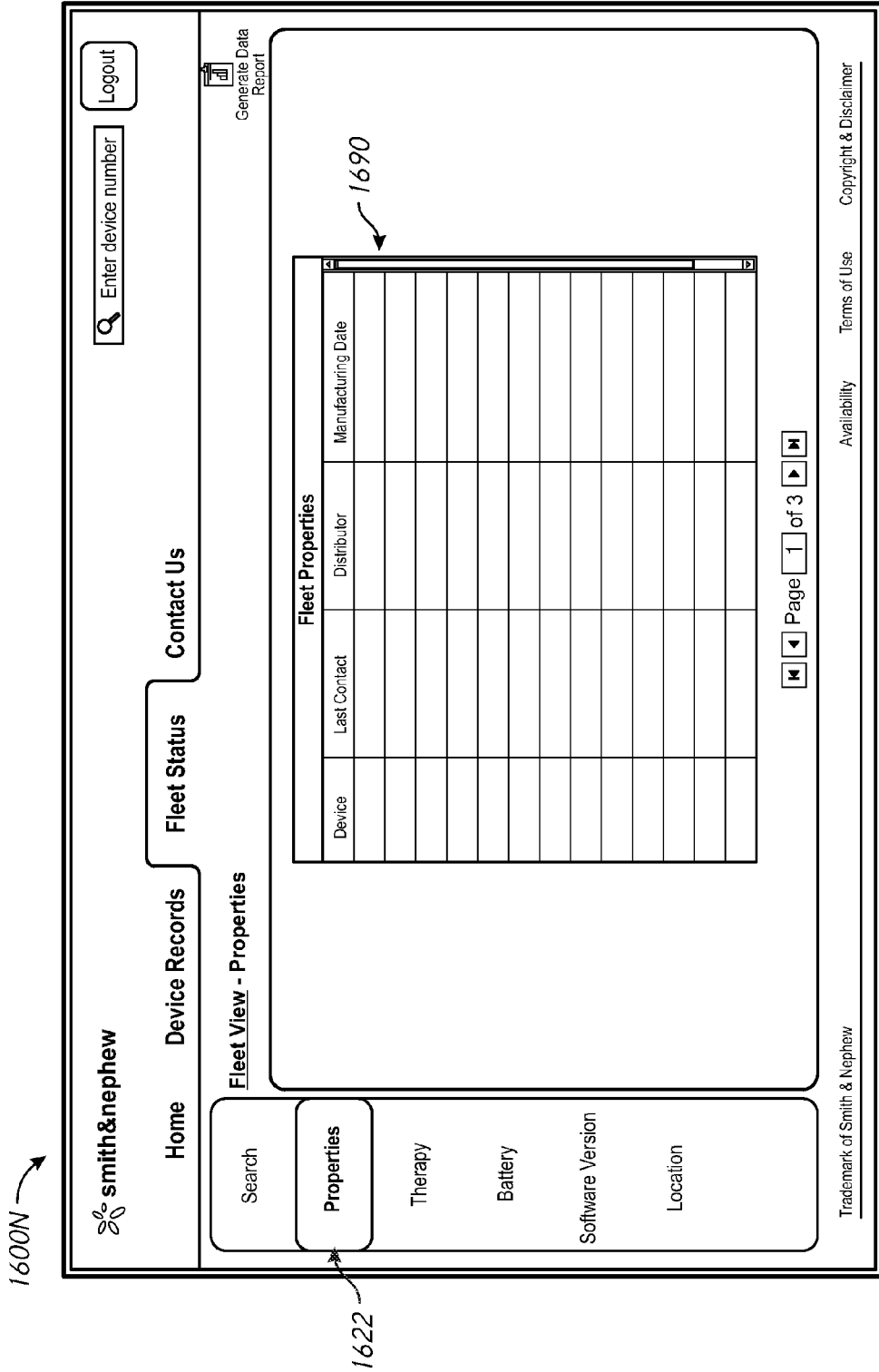

FIG. 16N

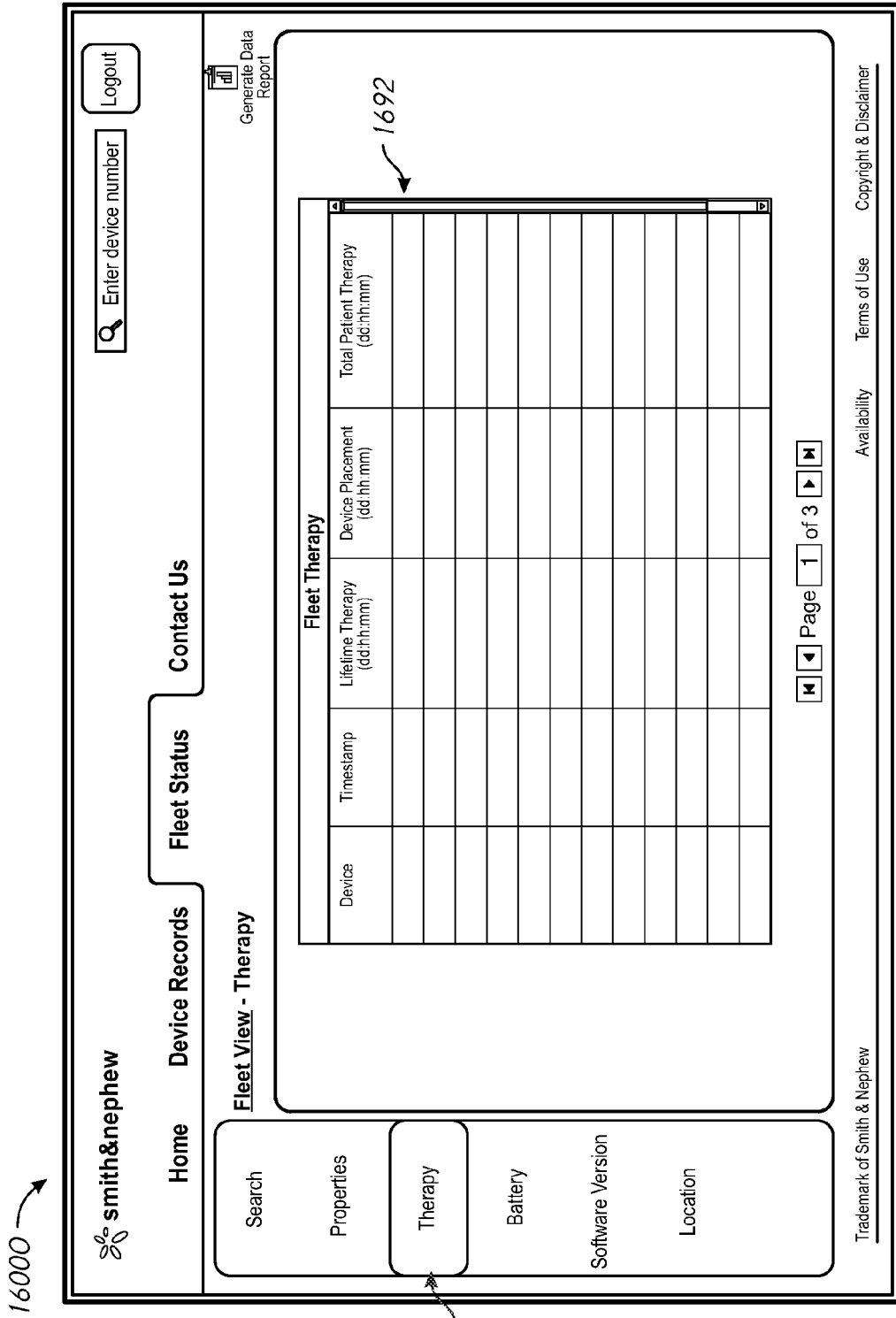

FIG. 160

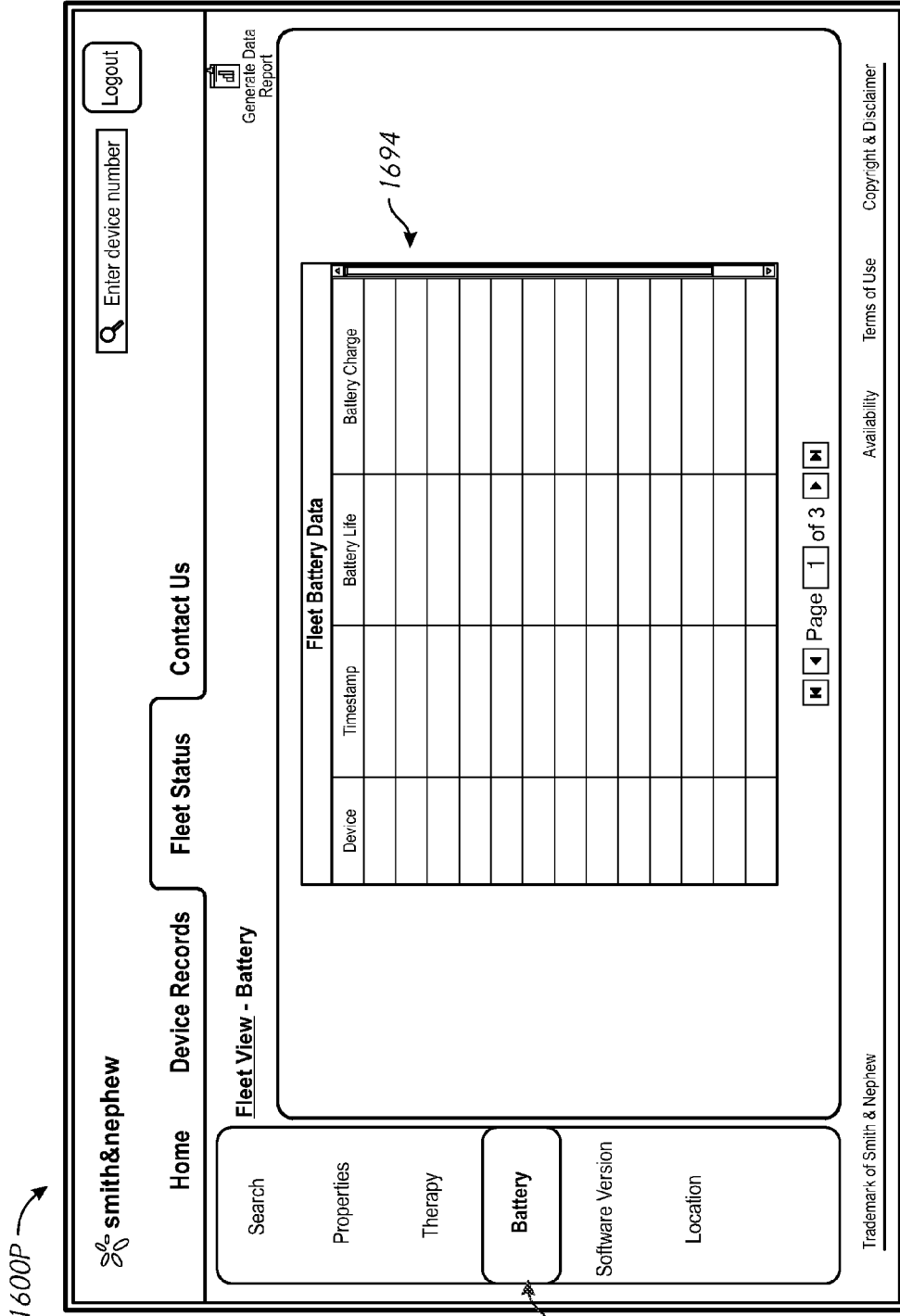

FIG. 16P

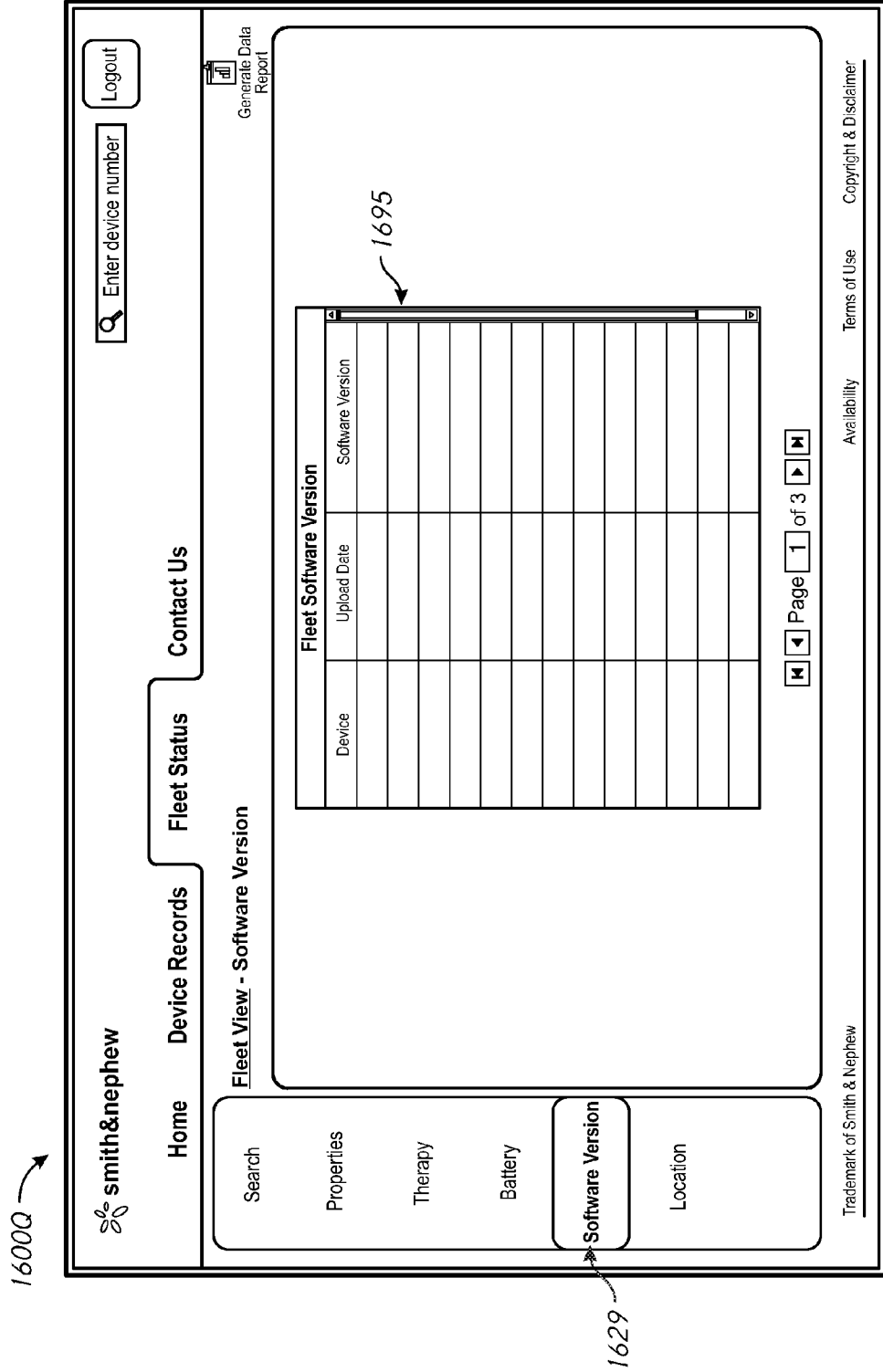

FIG. 16Q

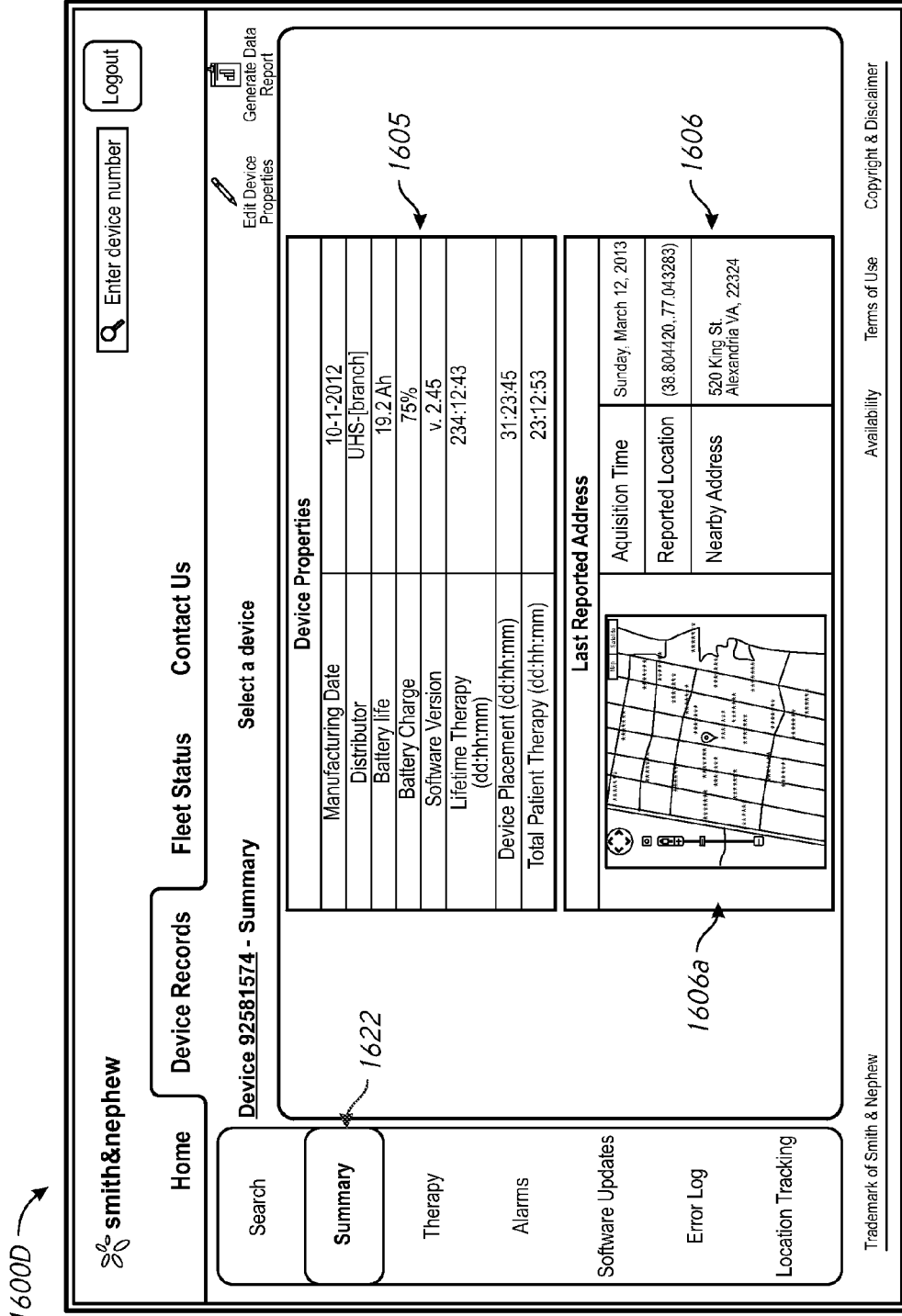

FIG. 16R

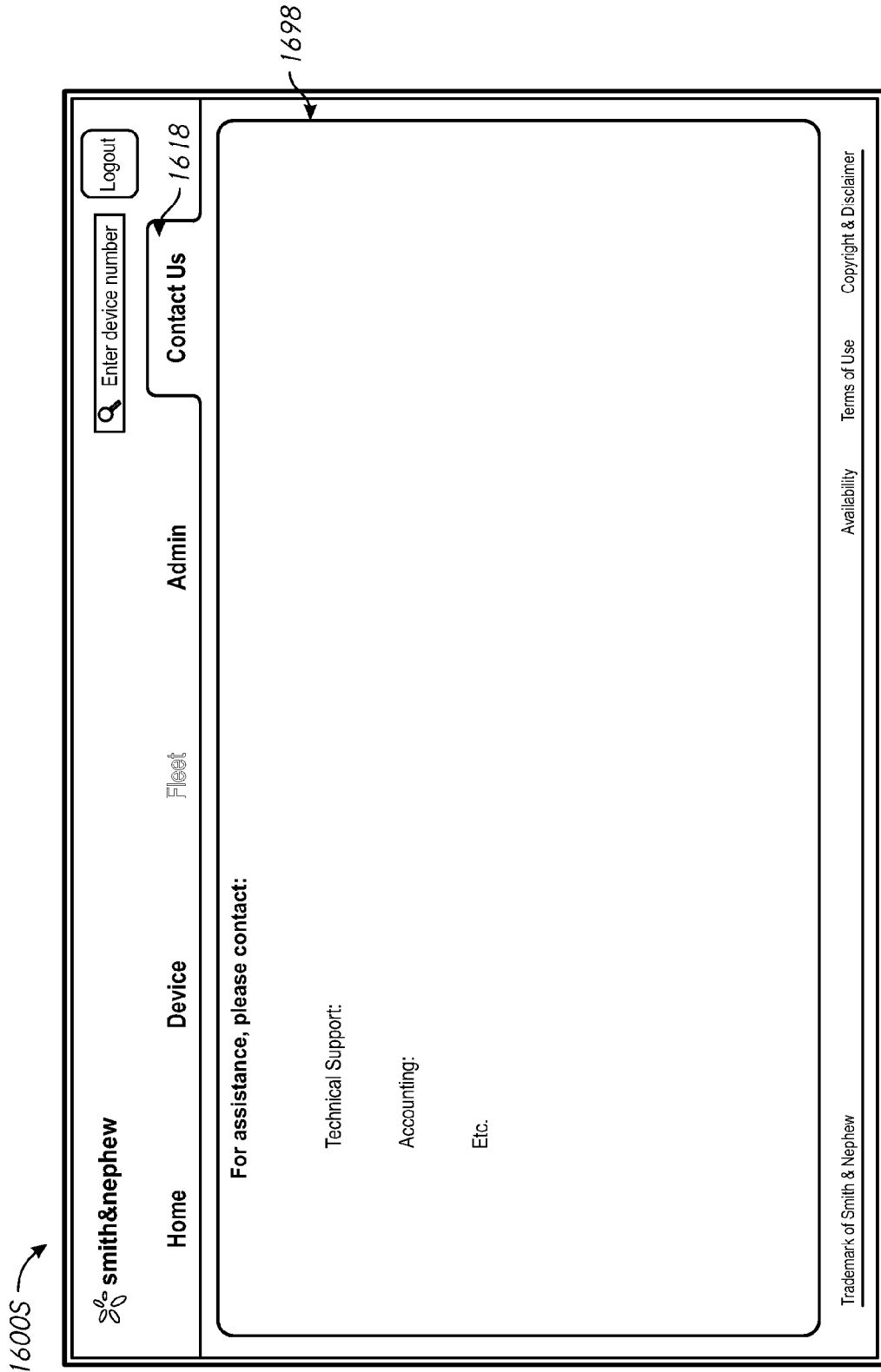

FIG. 16S

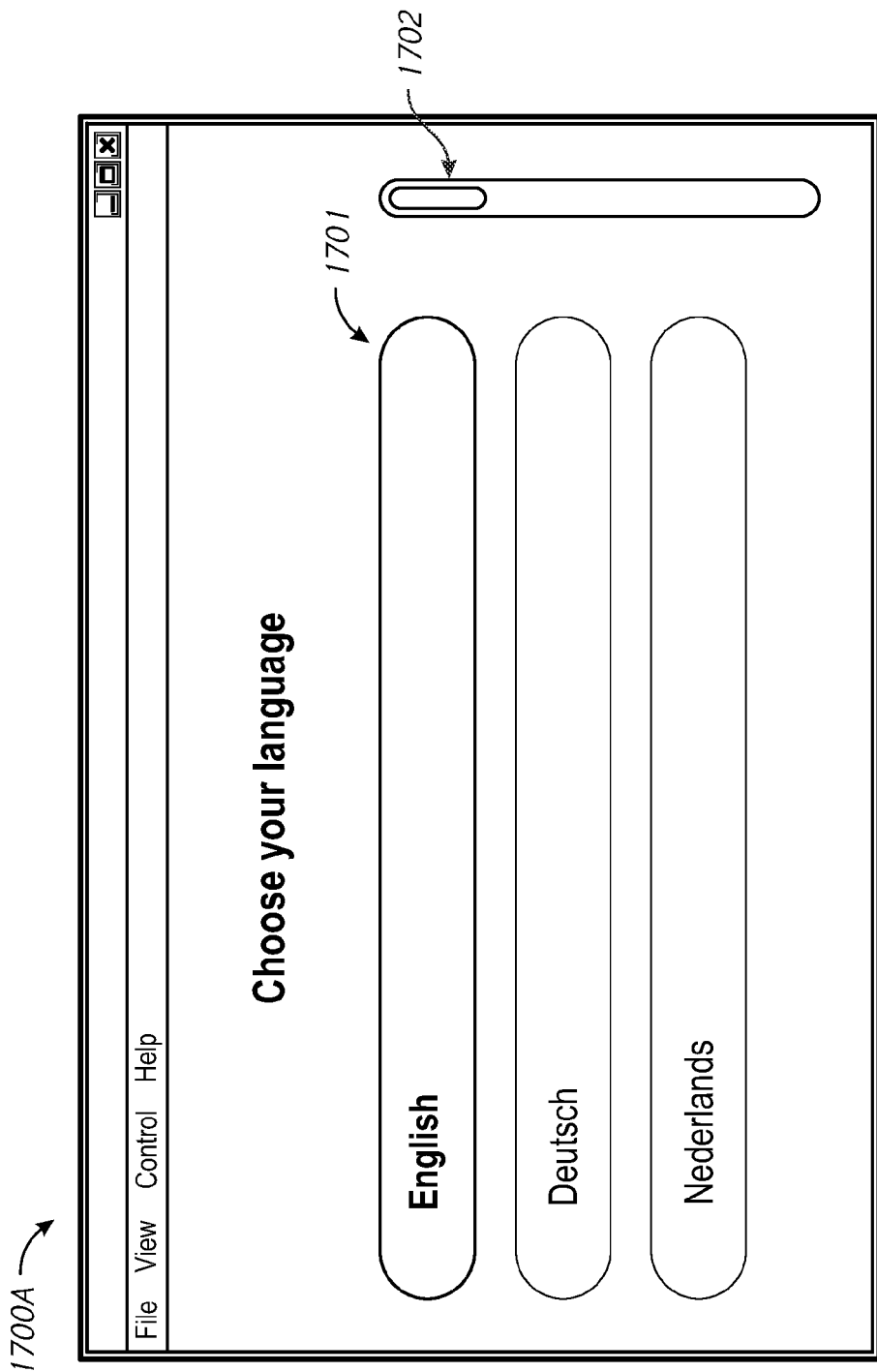

FIG. 17A

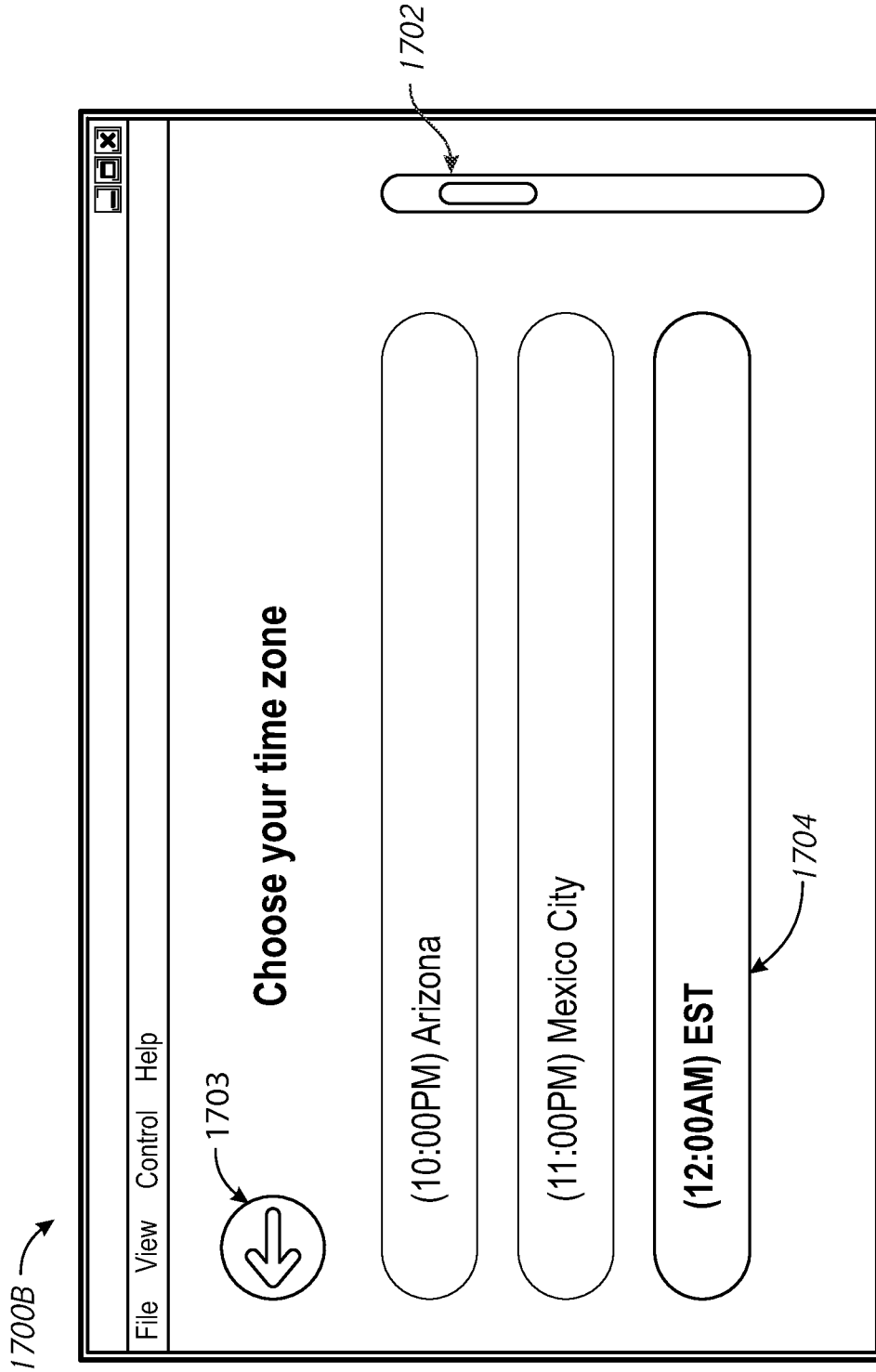

FIG. 17B

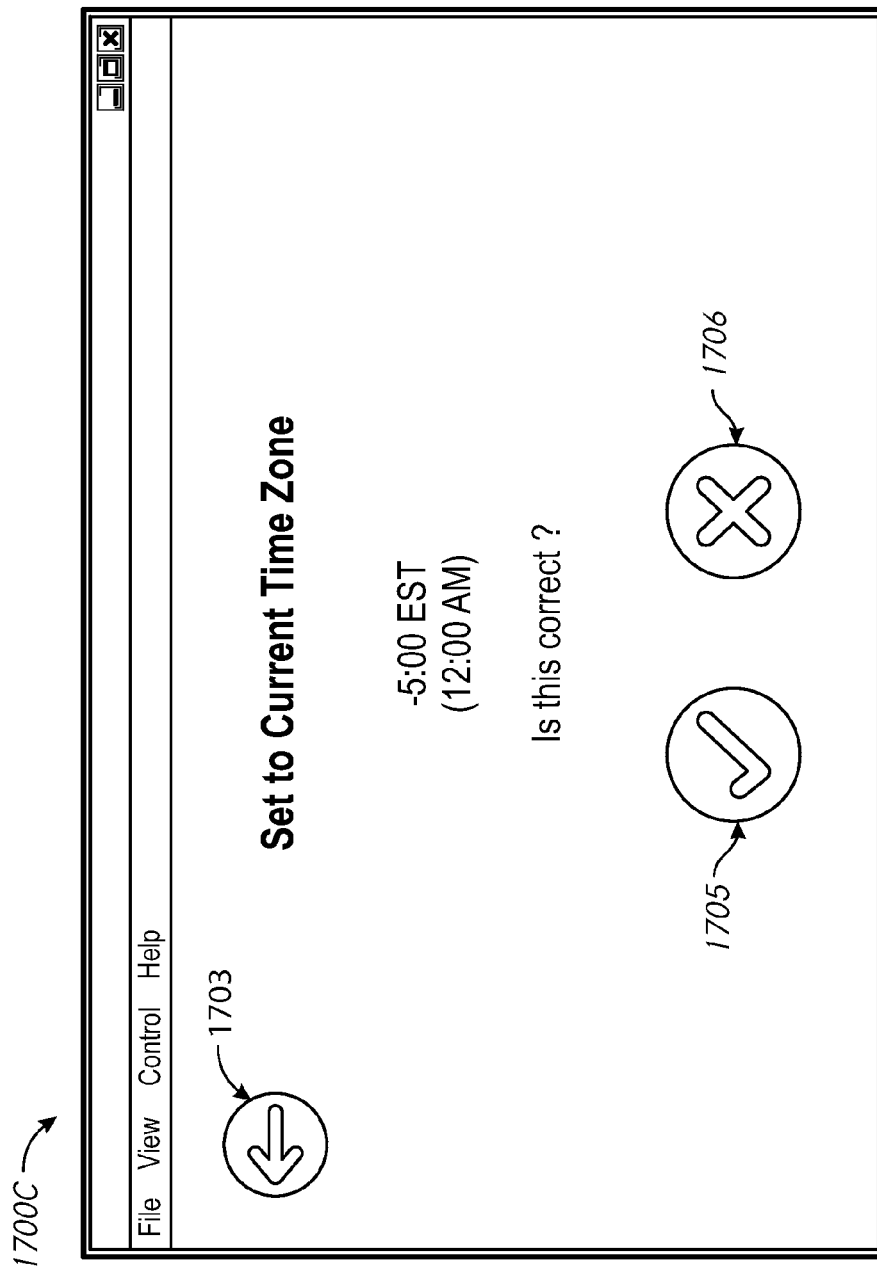

FIG. 17C

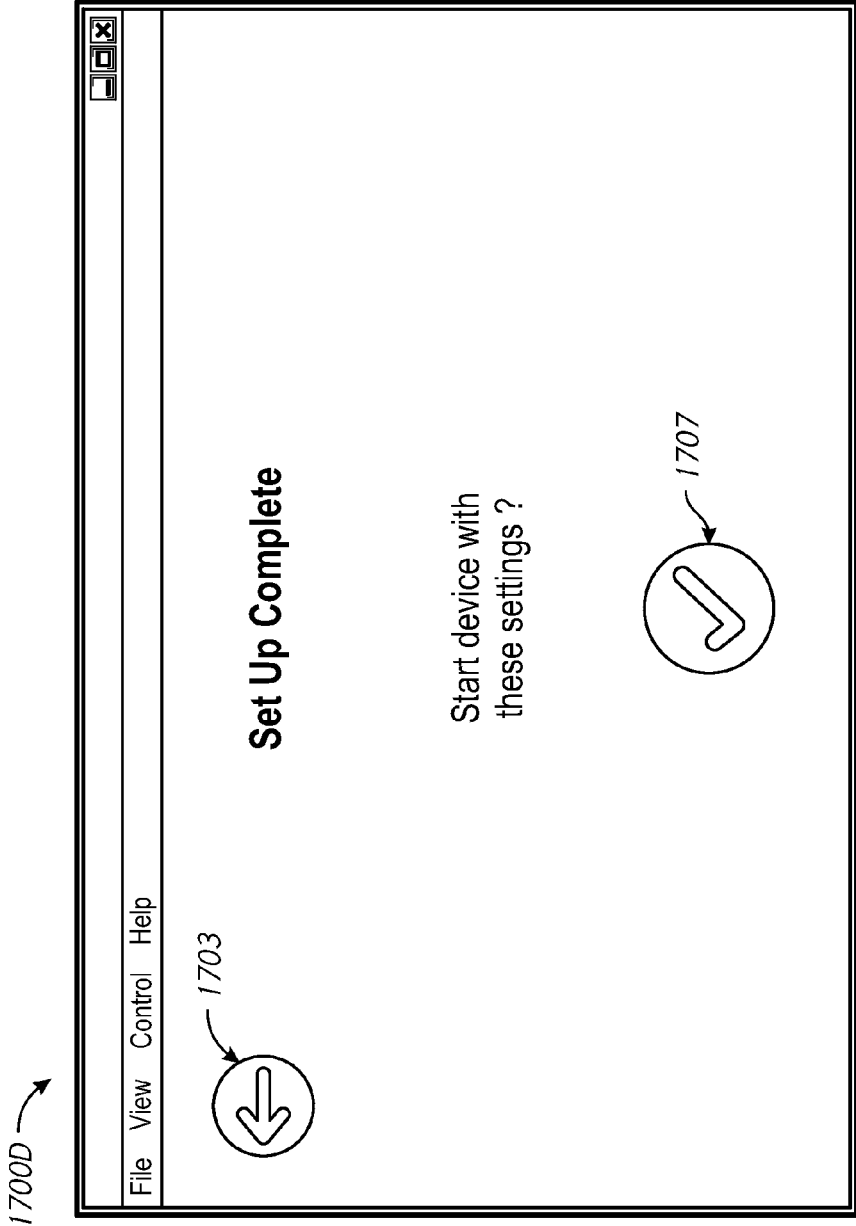

FIG. 17D

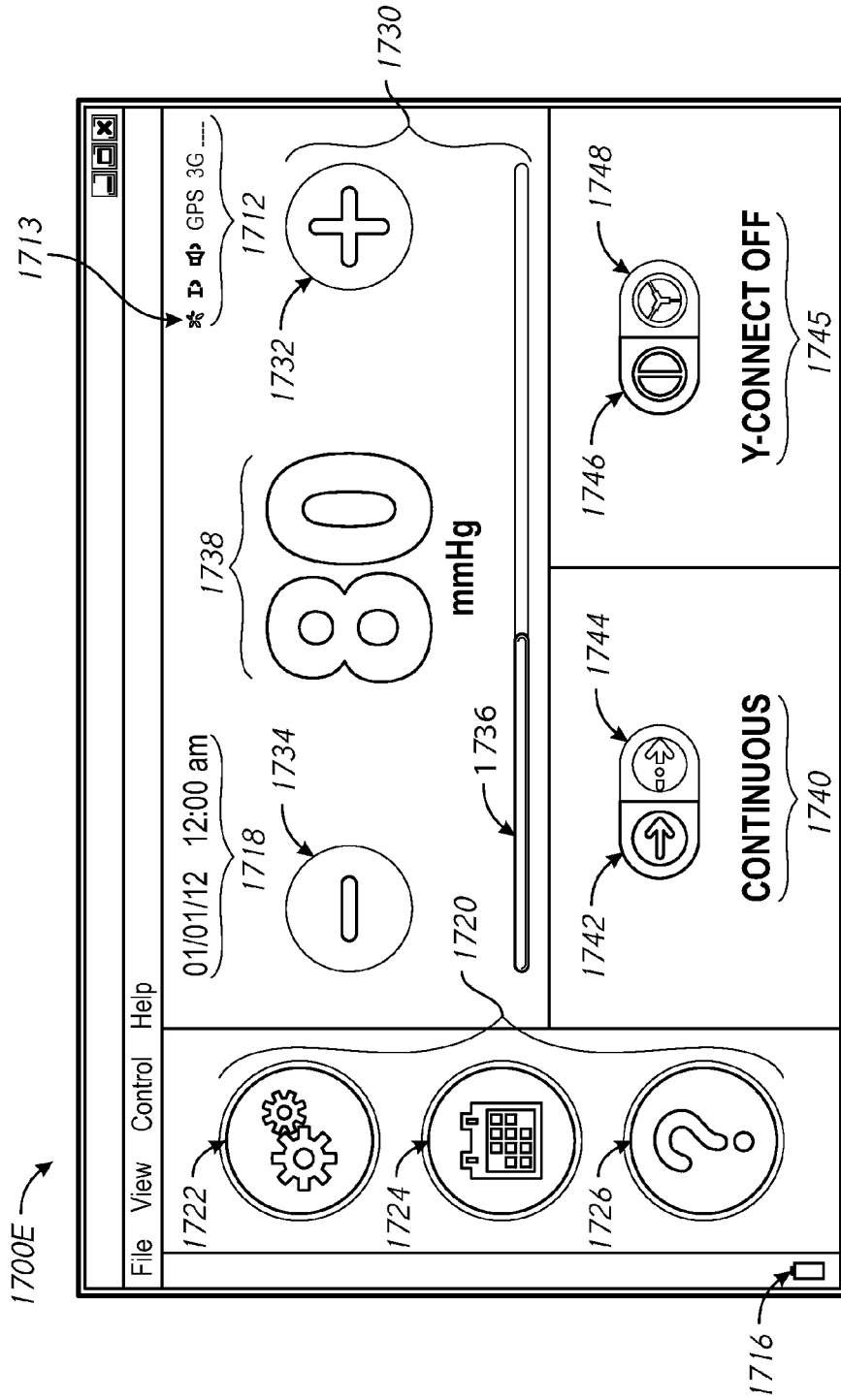

FIG. 17E

1700F

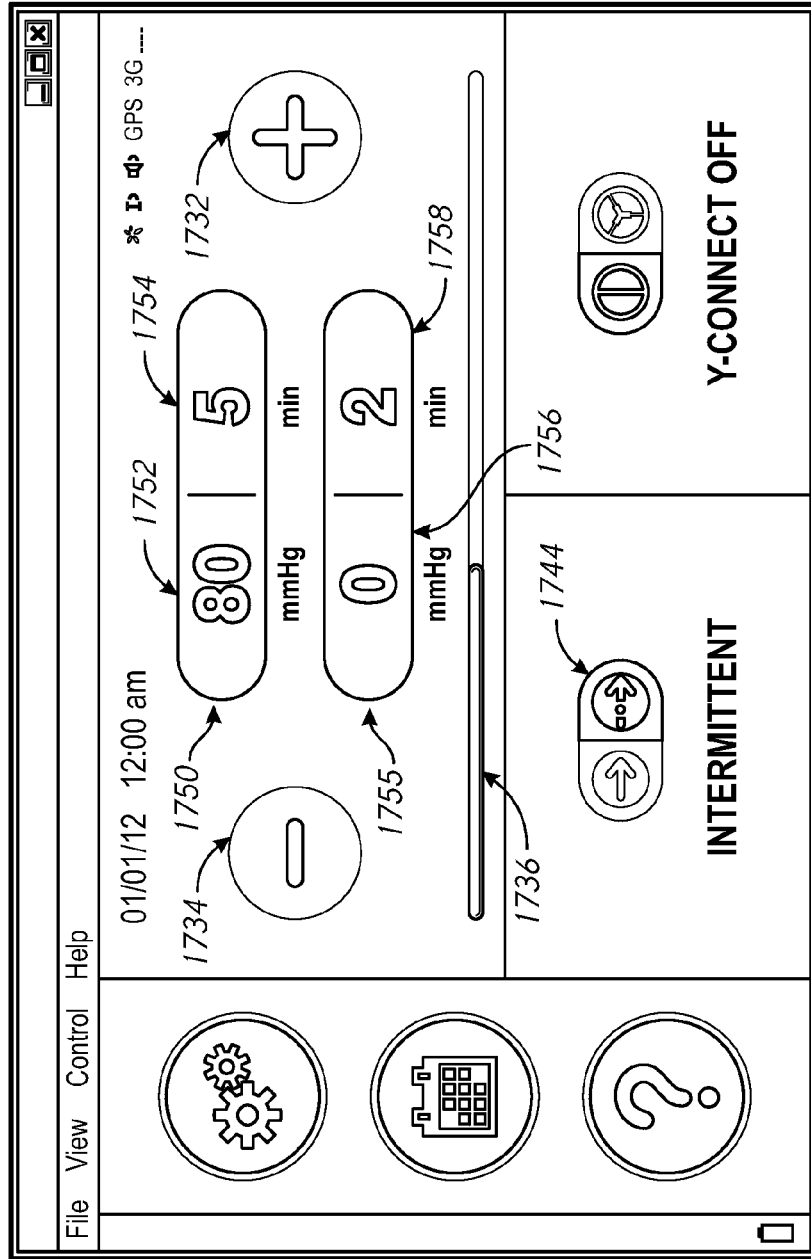

FIG. 17F

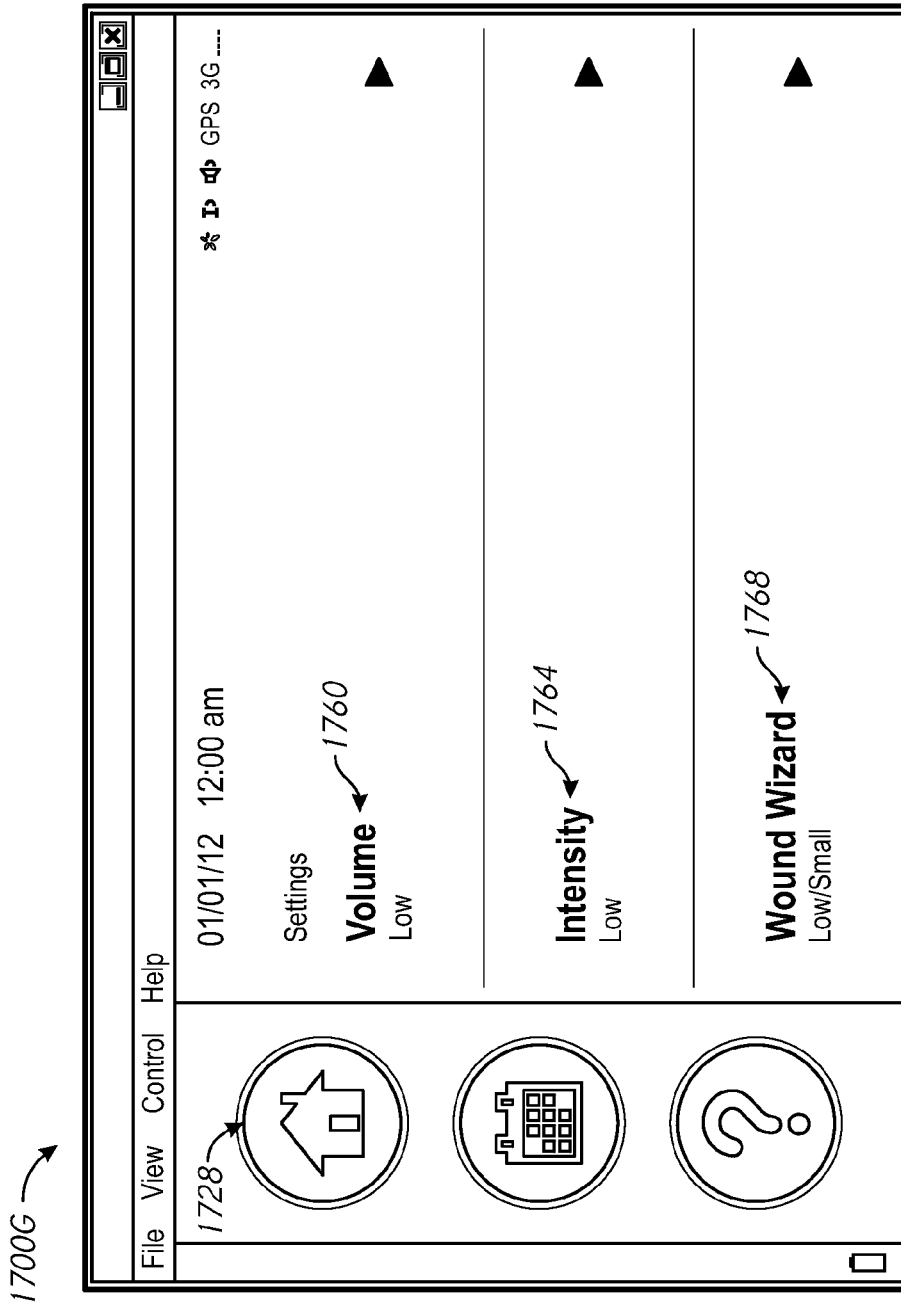

FIG. 17G

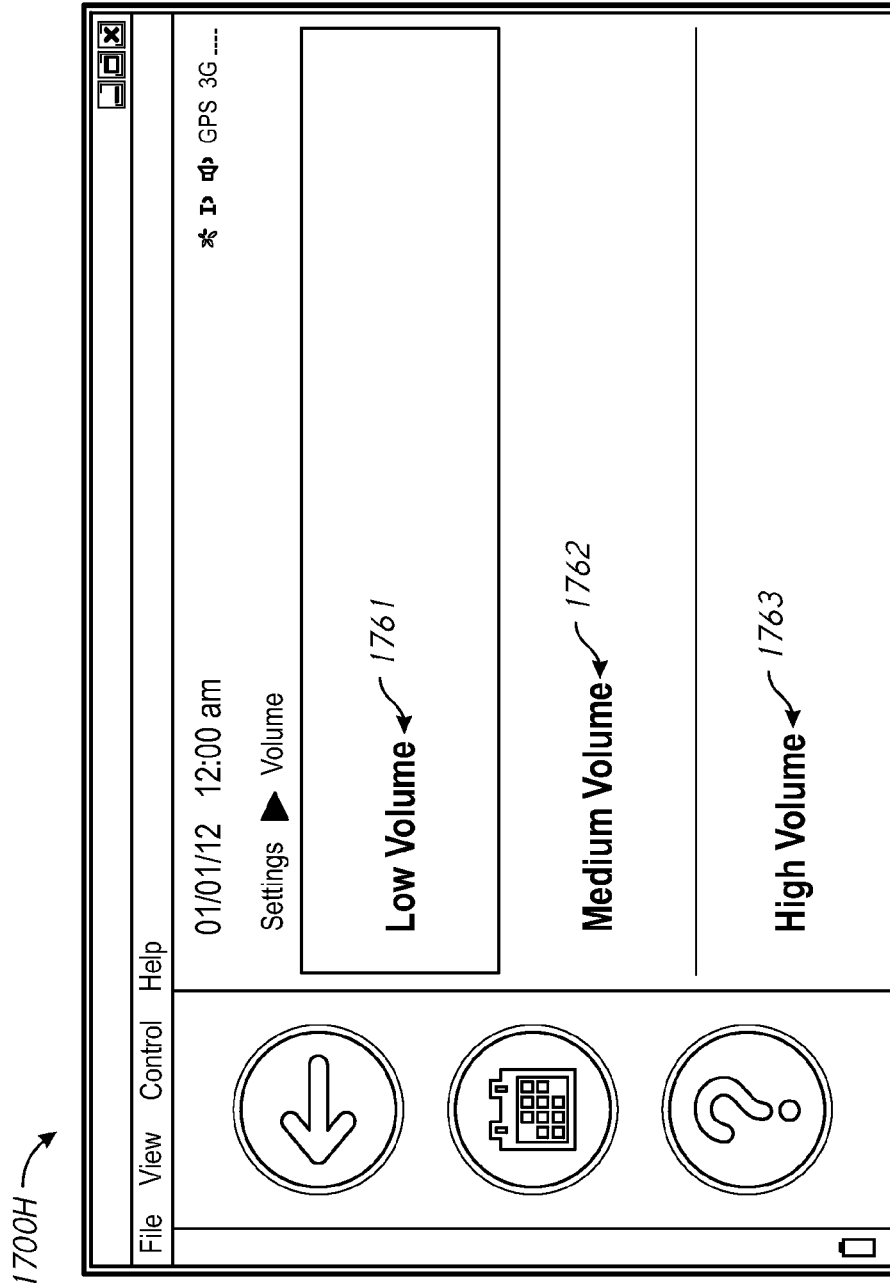

FIG. 17H

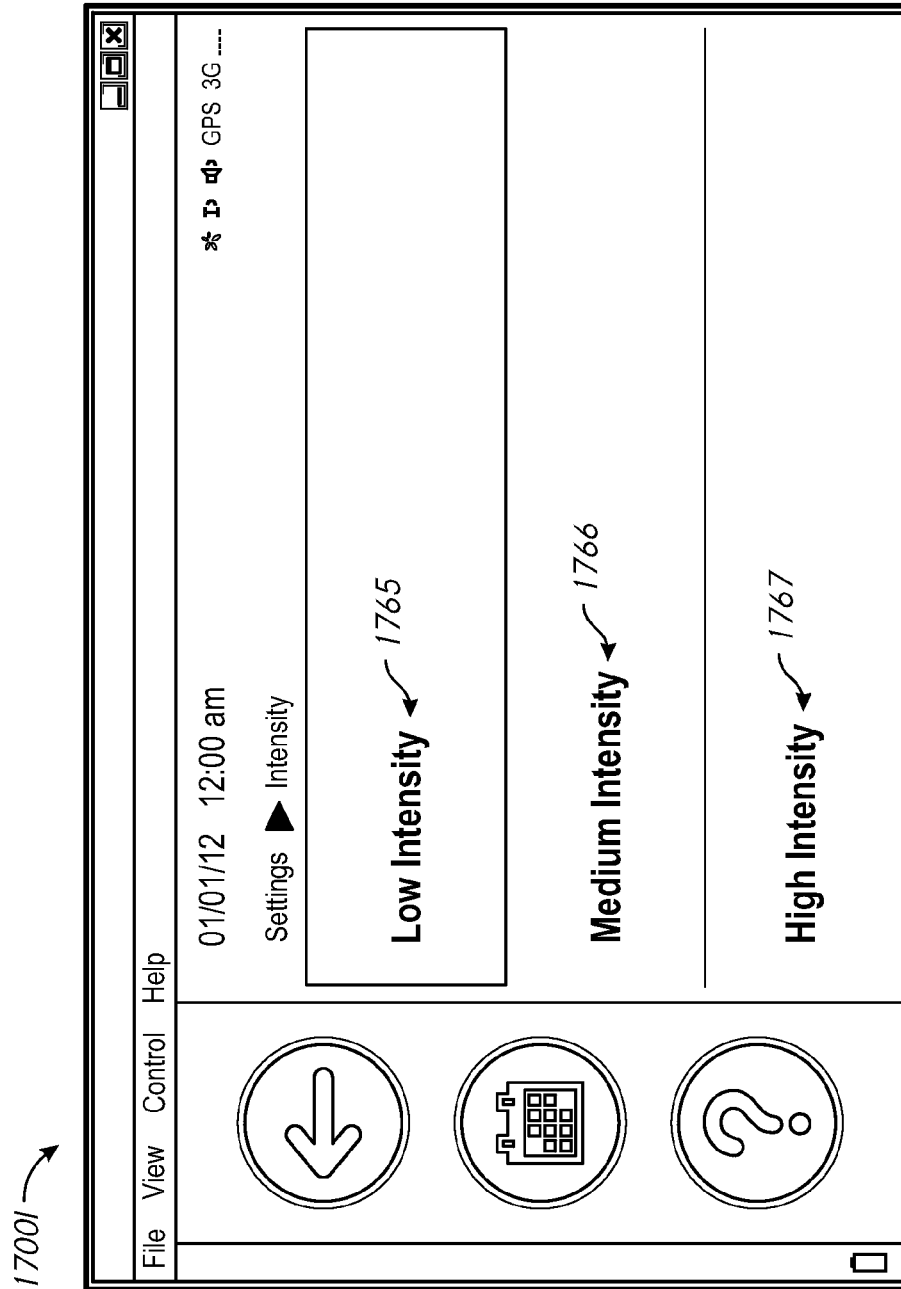

FIG. 171

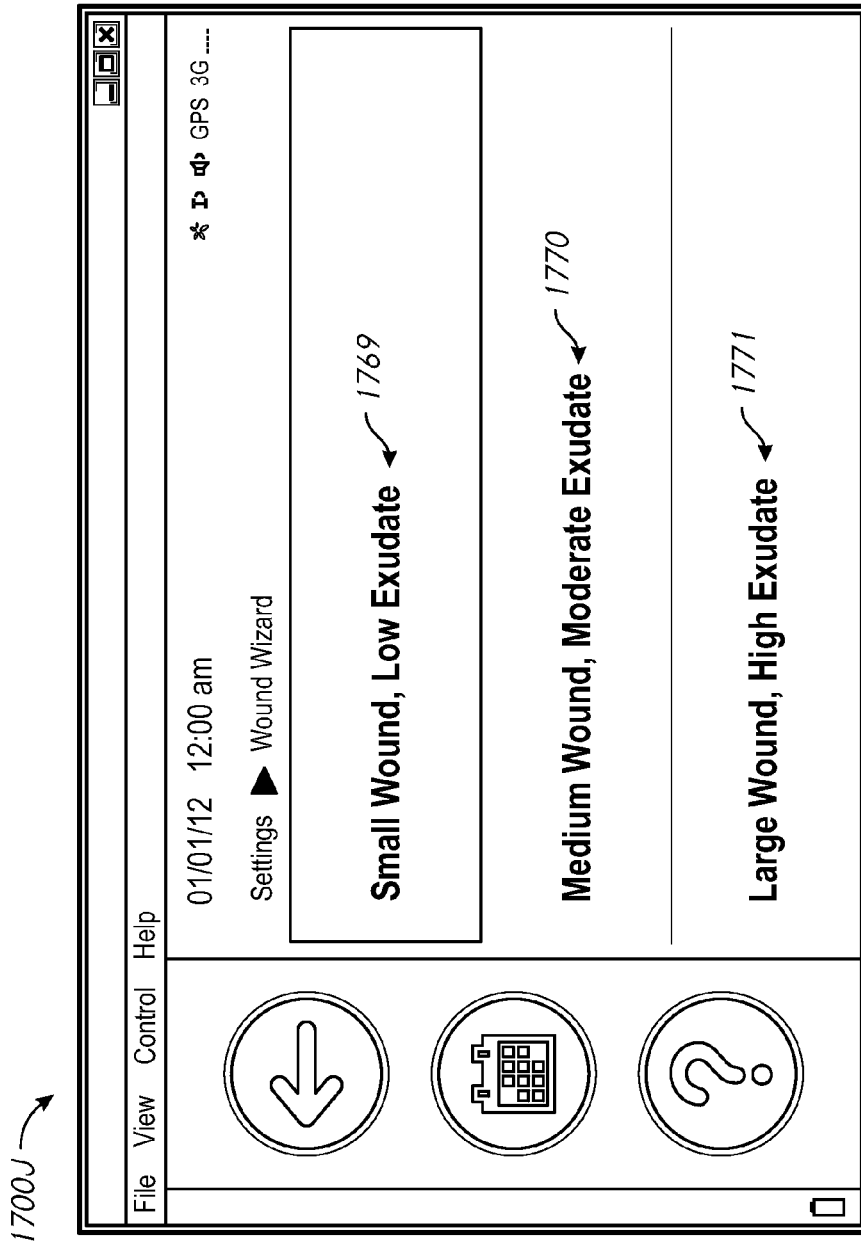

FIG. 17J

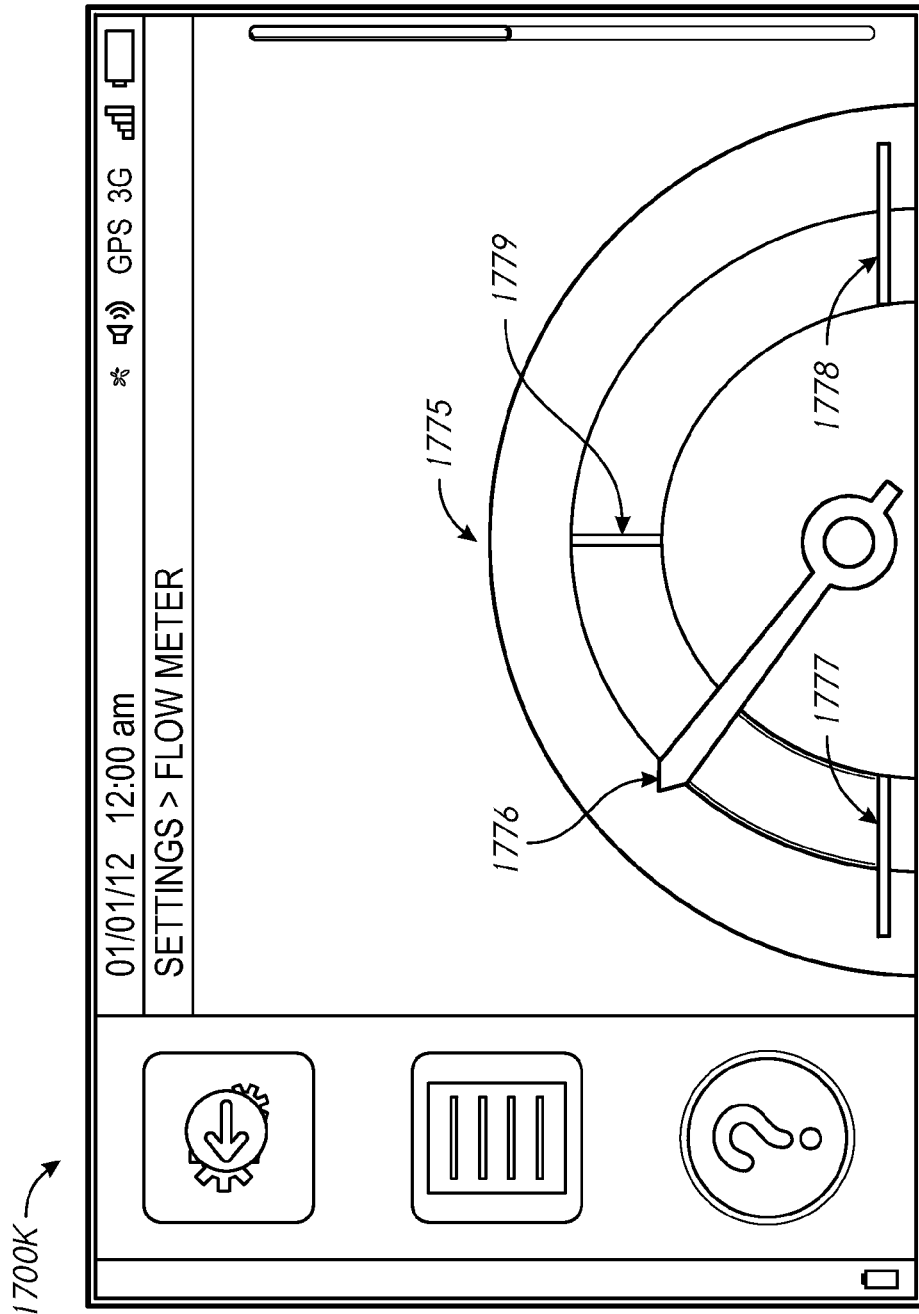

FIG. 17K

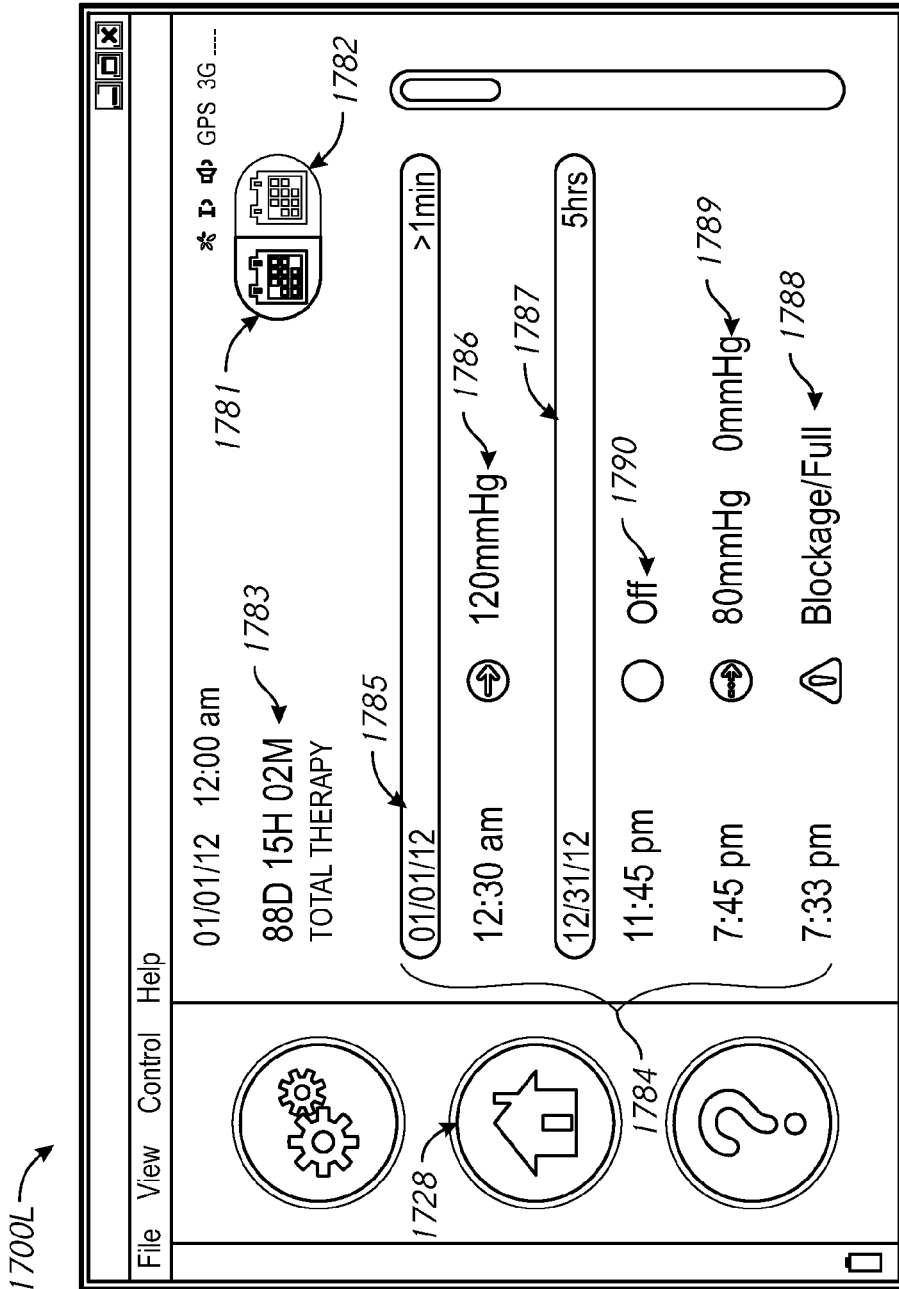

FIG. 17L

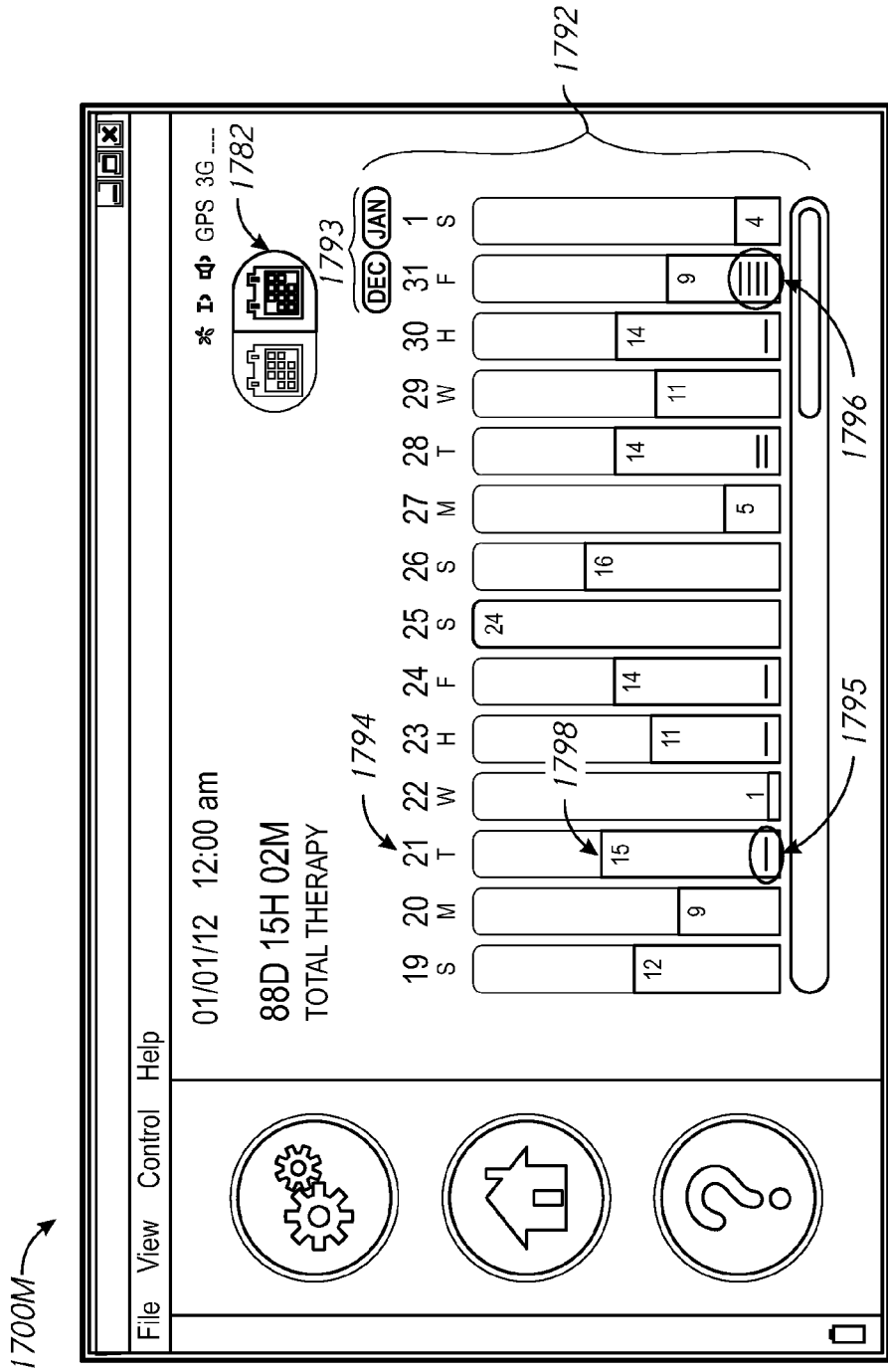

FIG. 17M

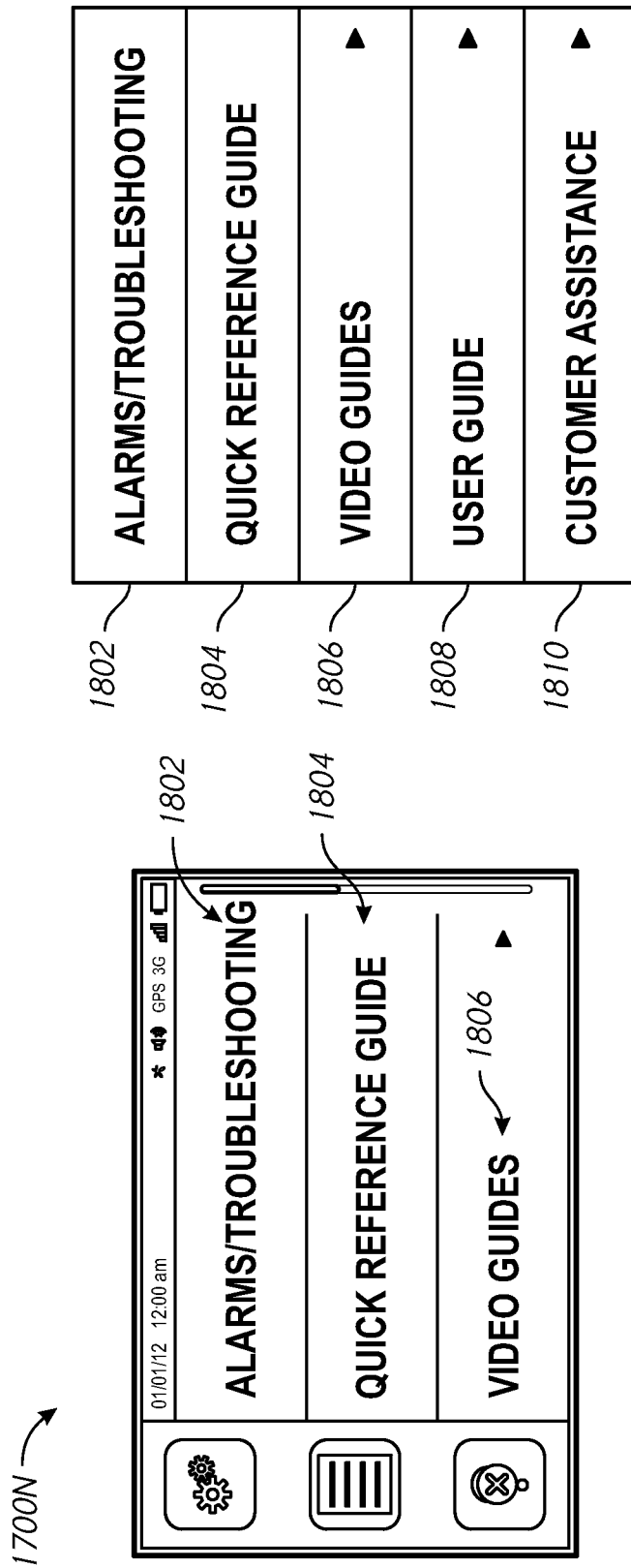

FIG. 17N

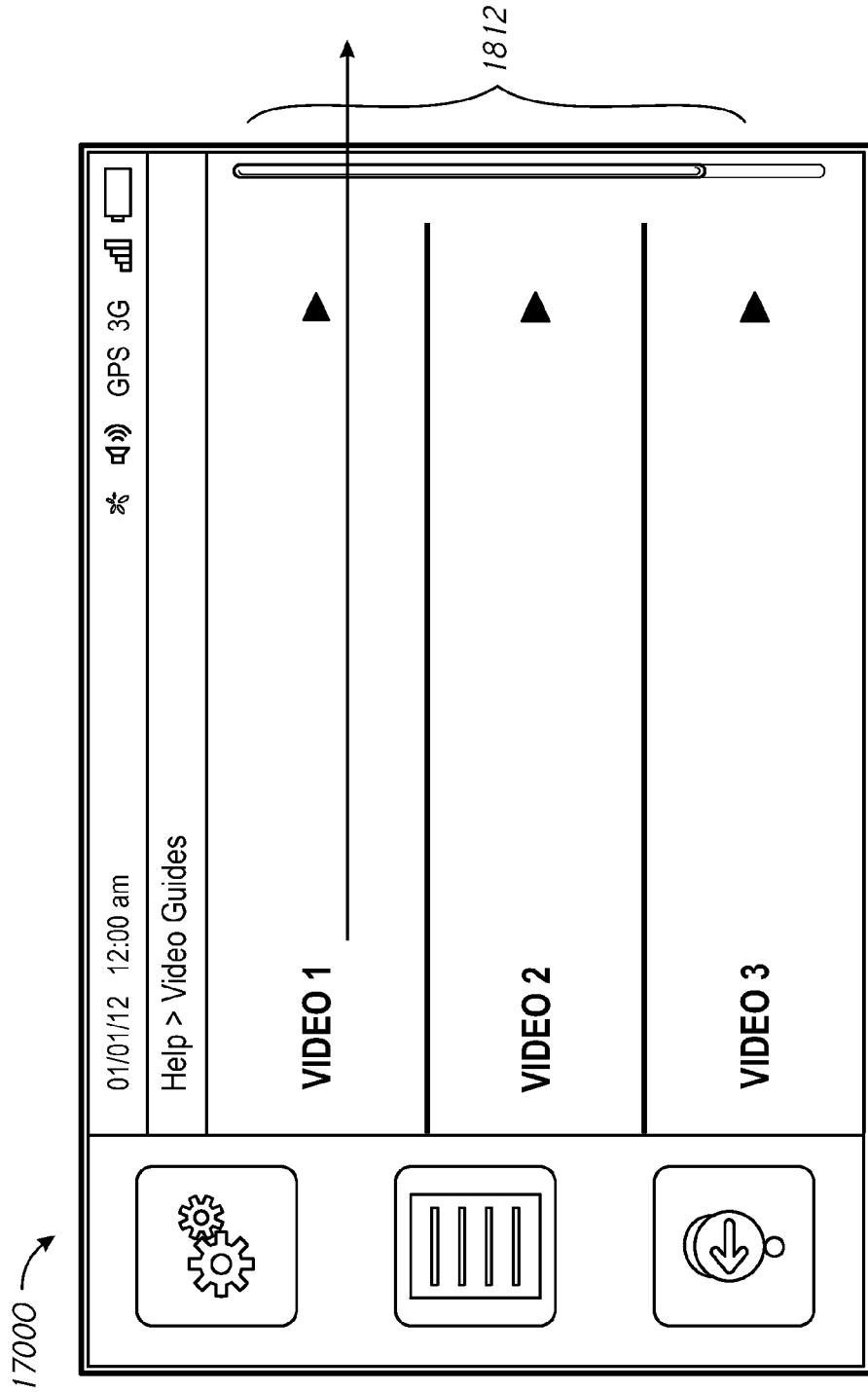

FIG. 170

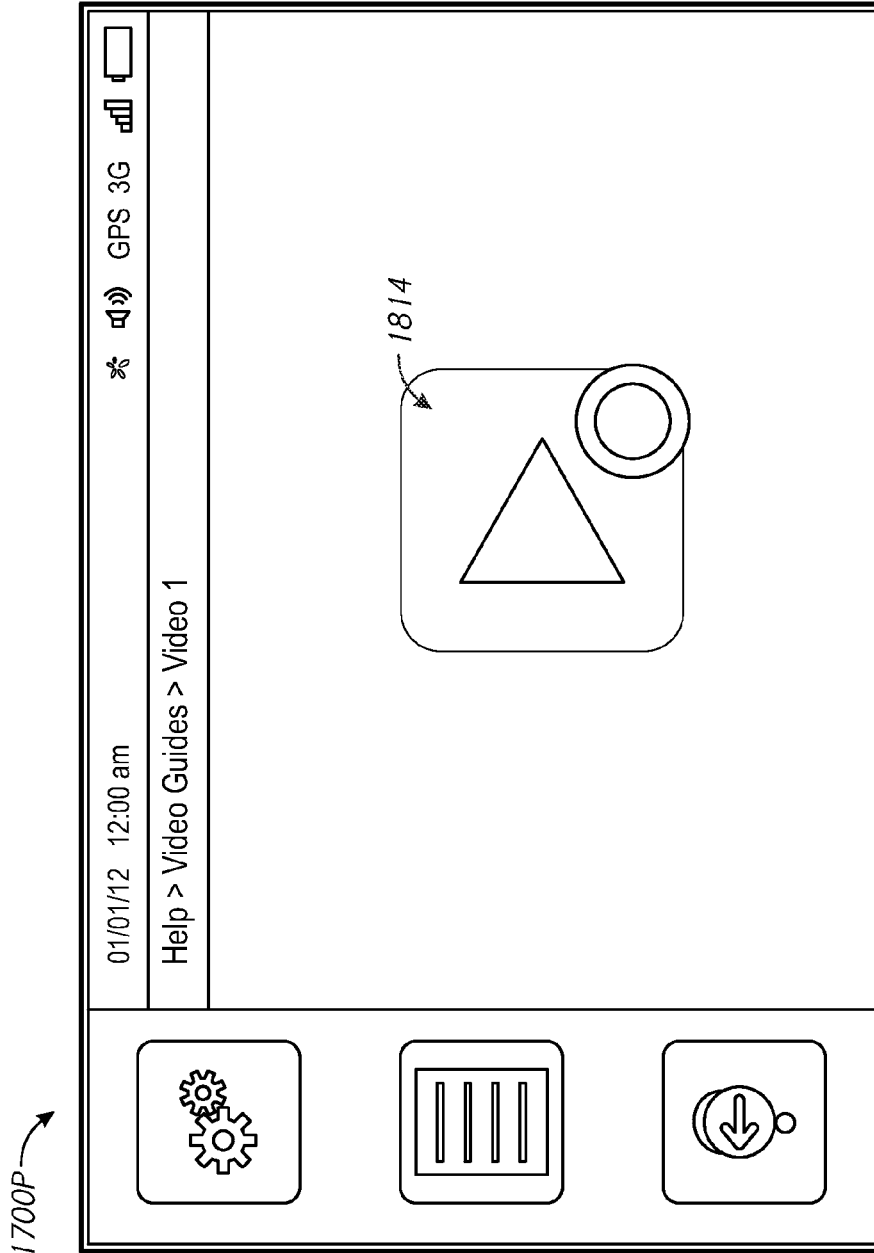

FIG. 17P

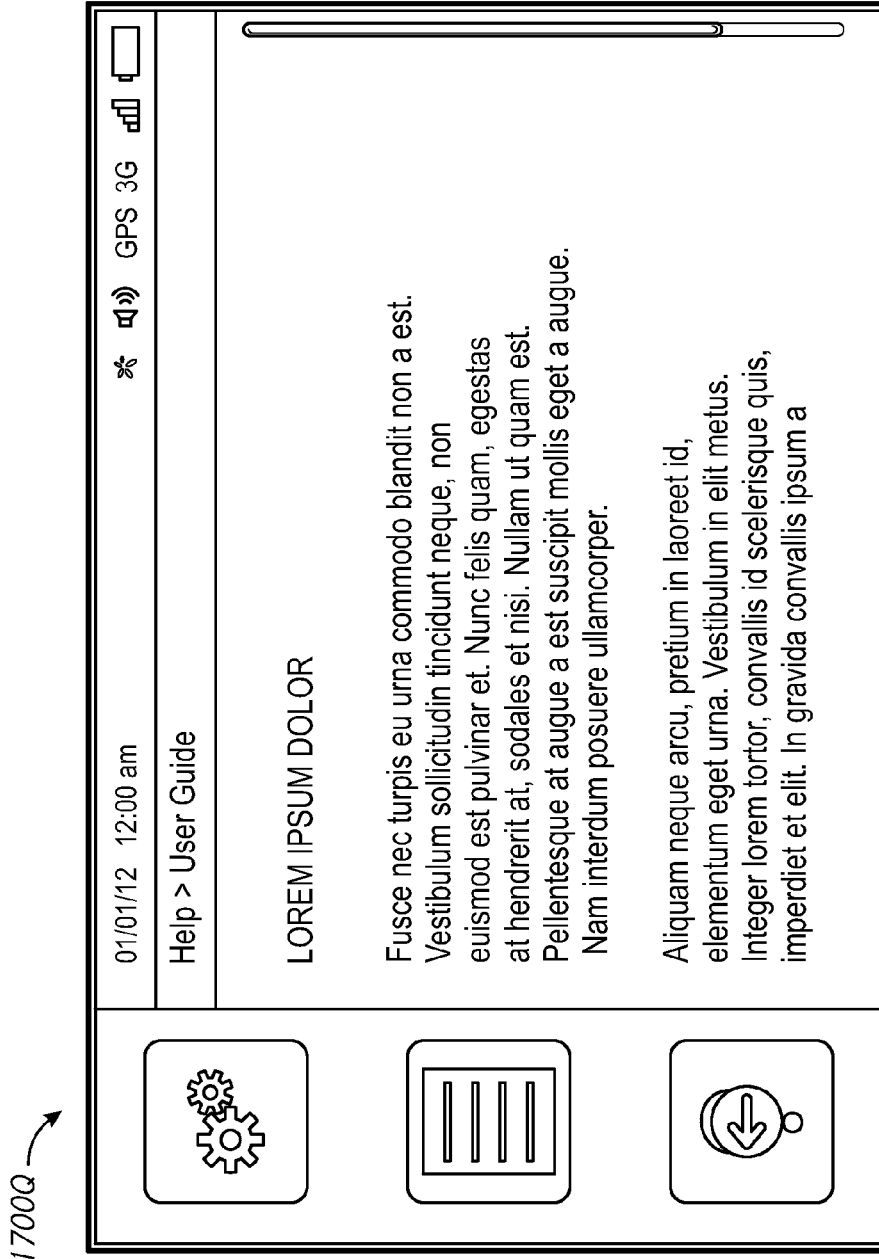

FIG. 170Q

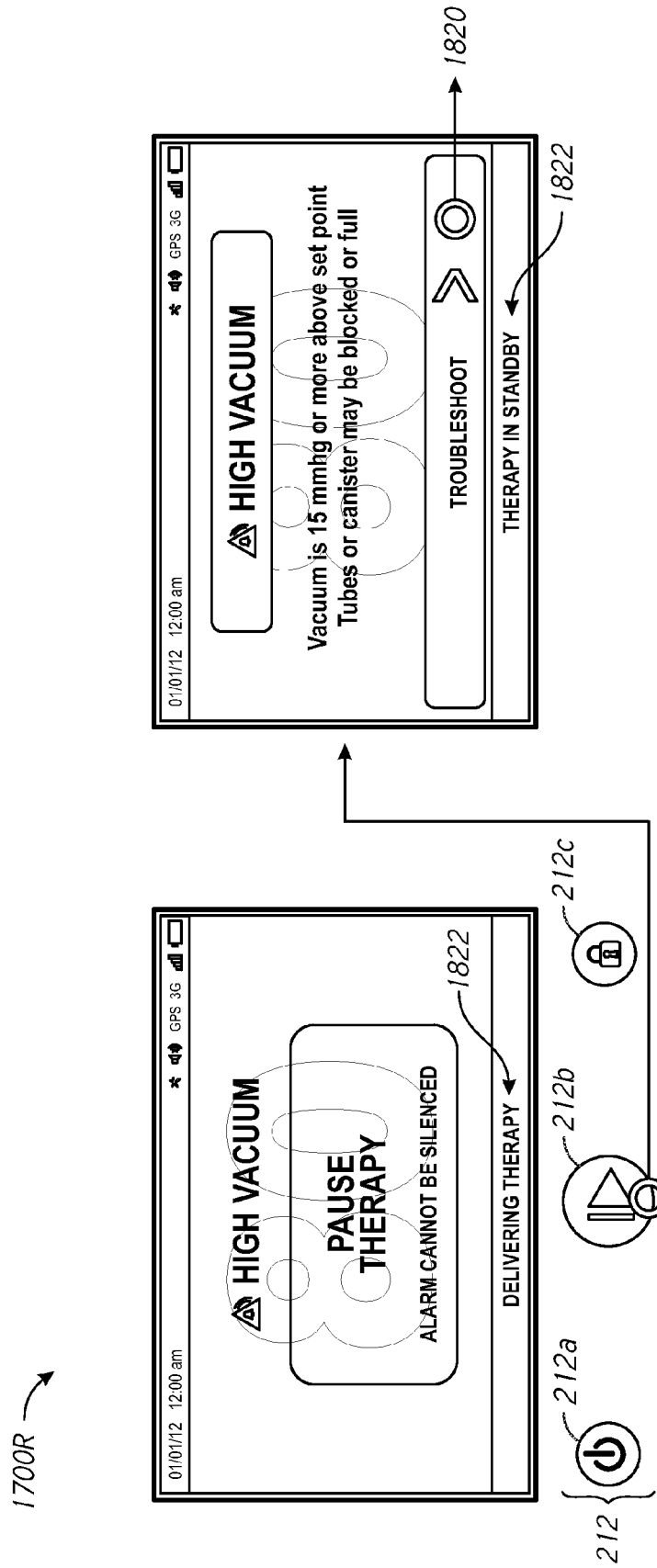

FIG. 17R

1700S

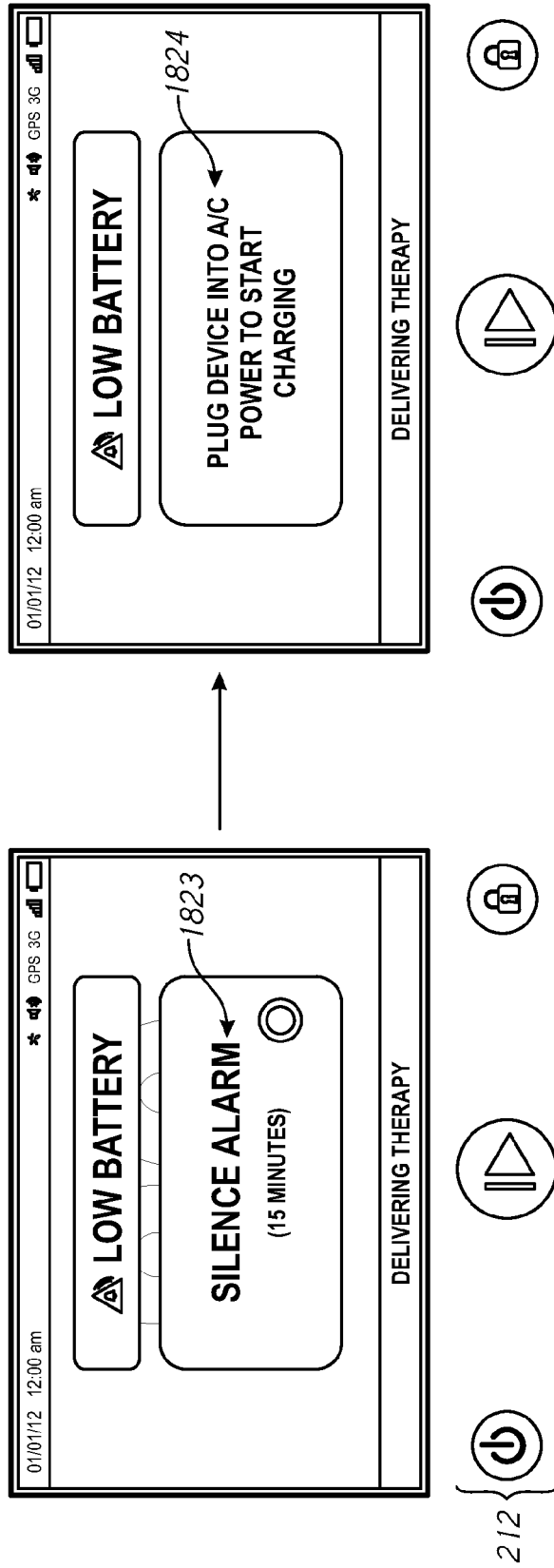

FIG. 17S

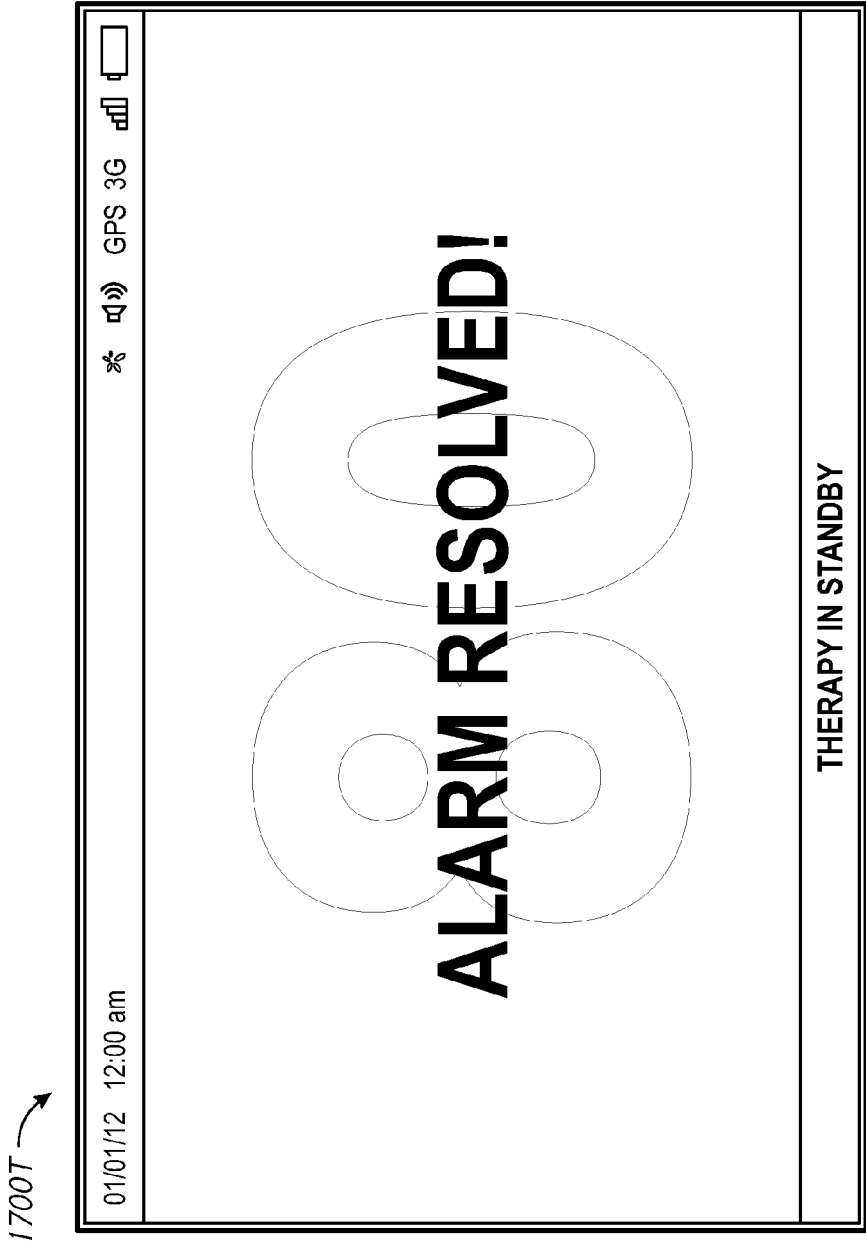

FIG. 17T

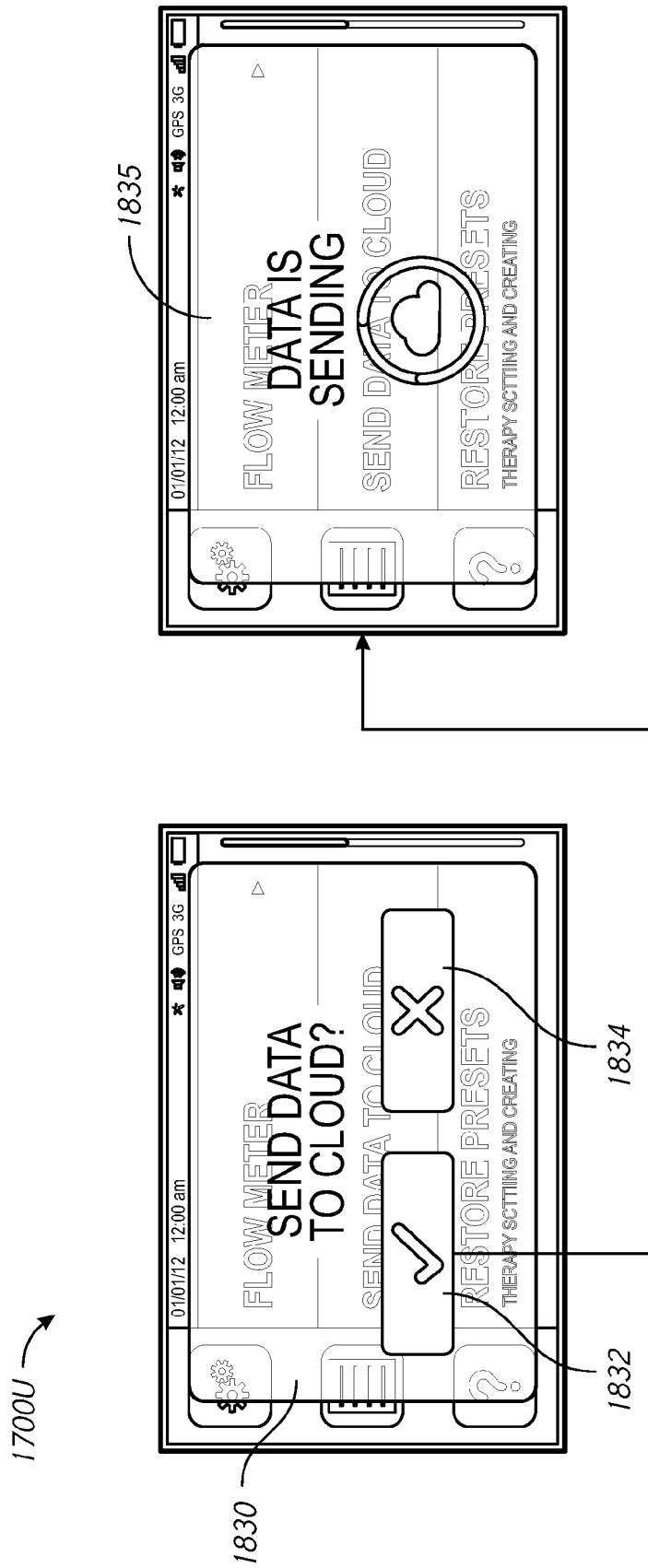
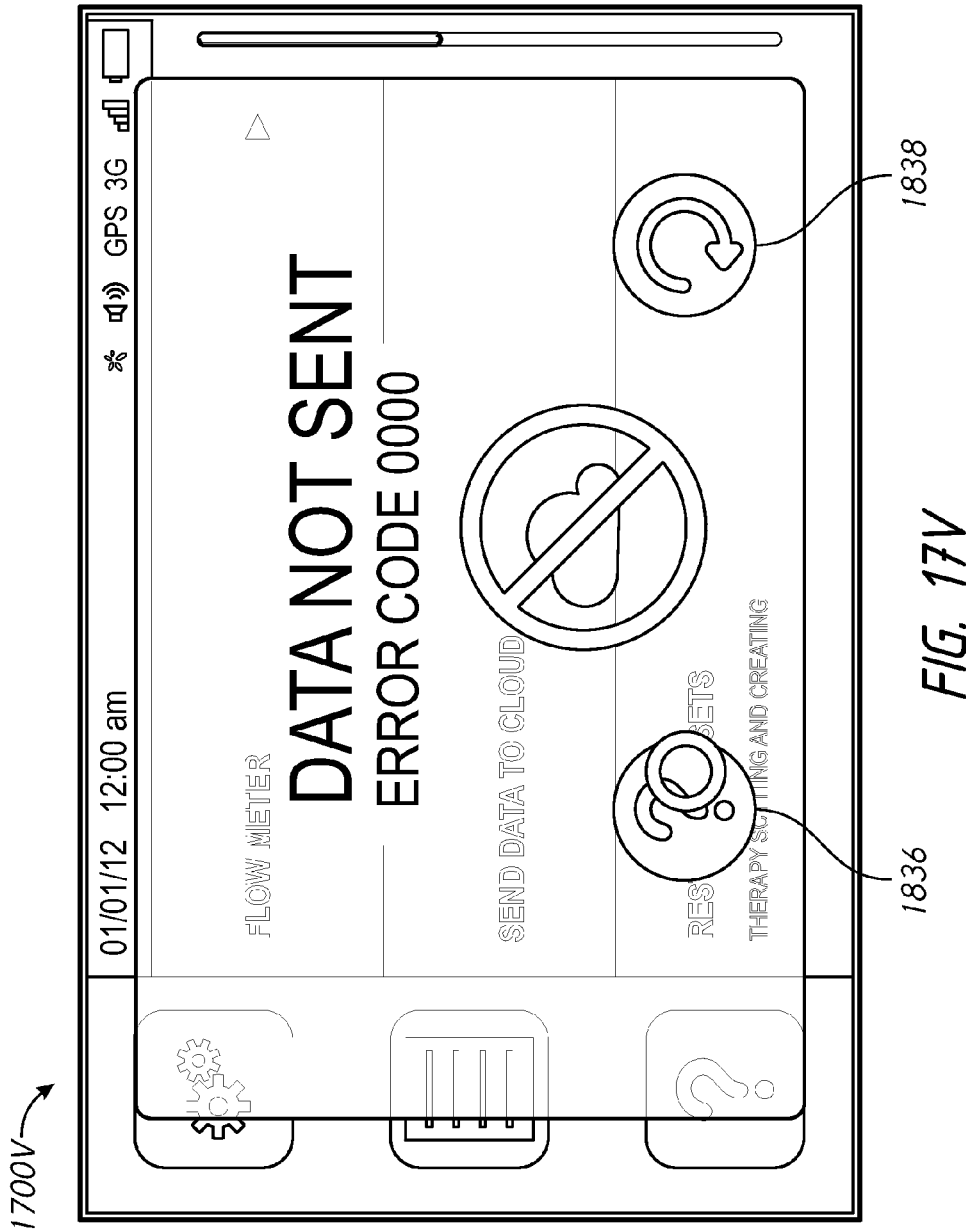

FIG. 17U



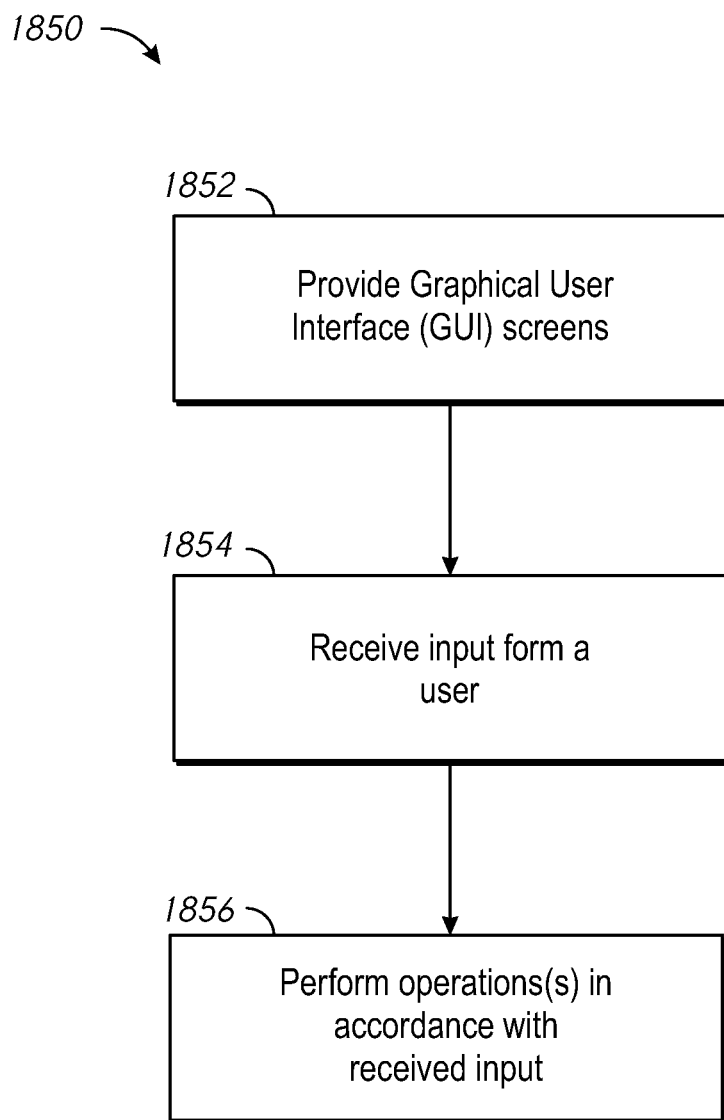

FIG. 18

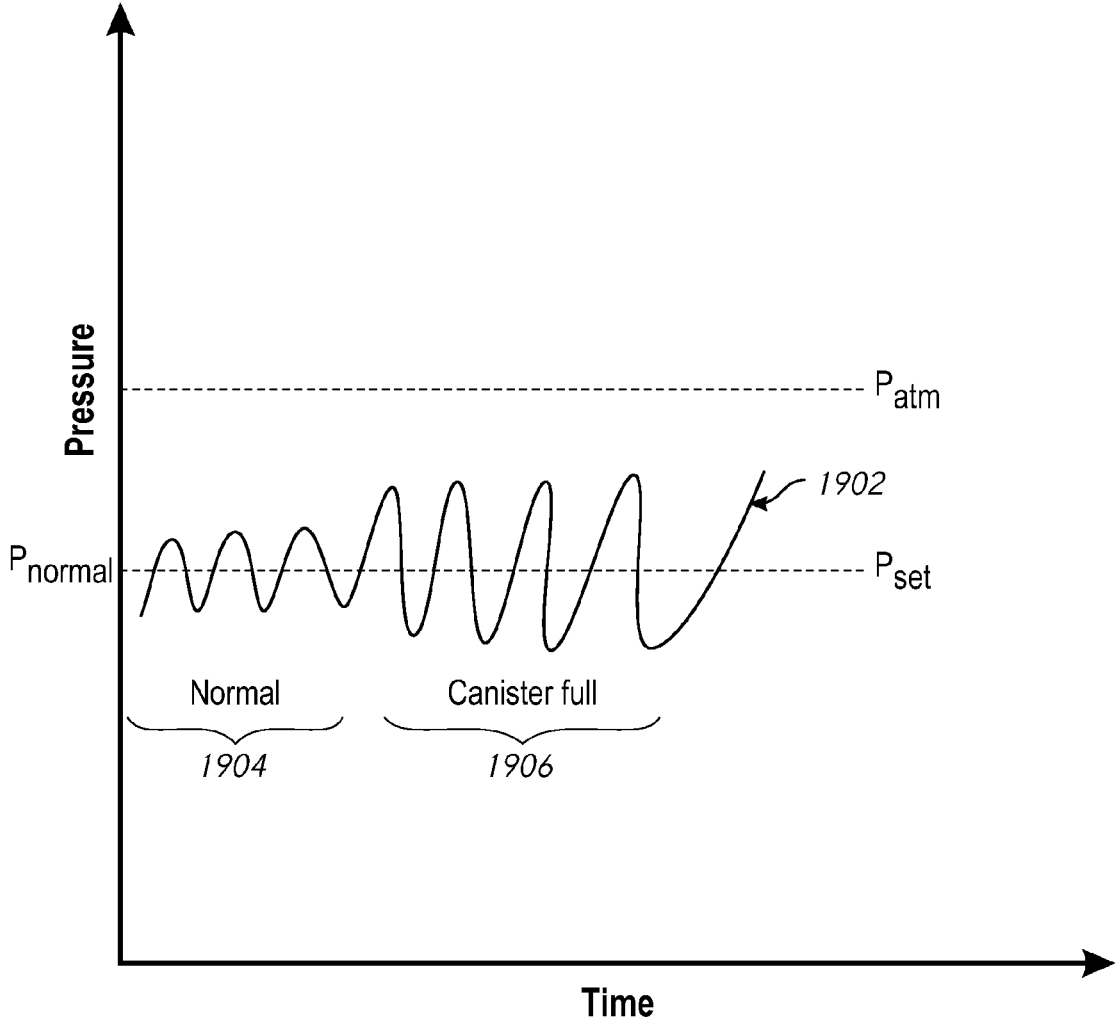

FIG. 19A

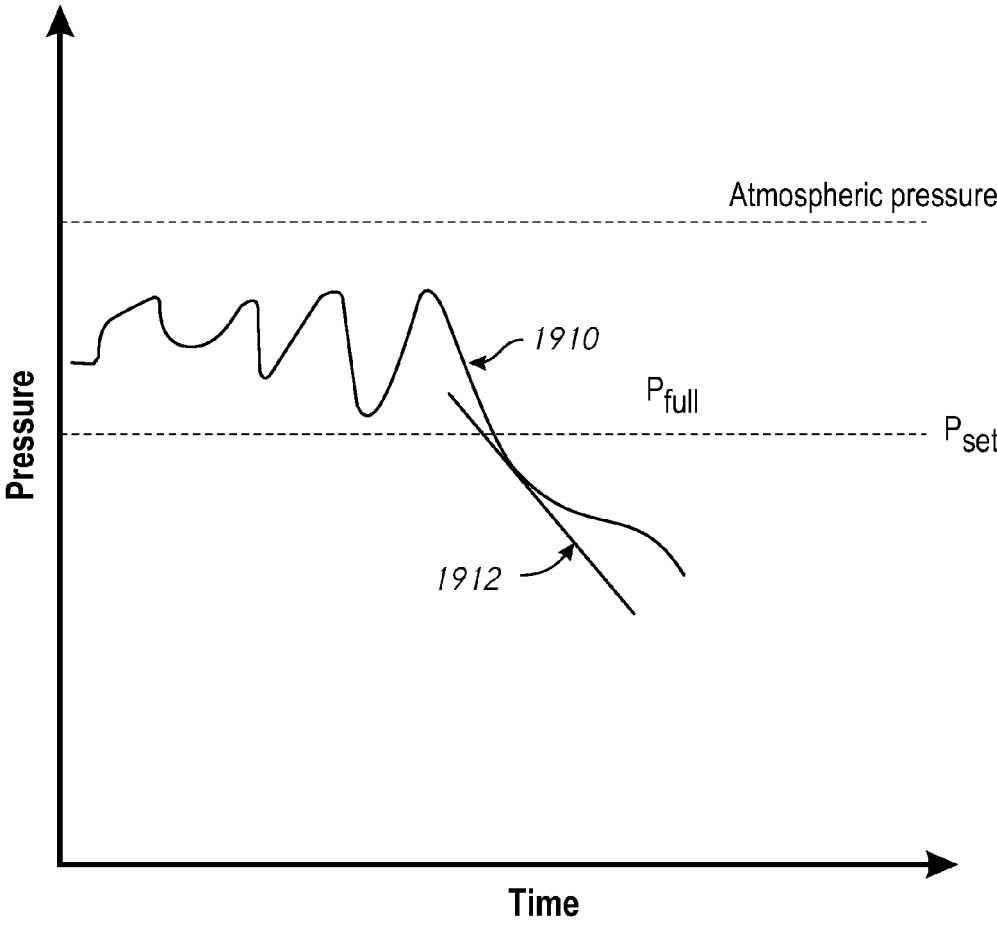

FIG. 19B

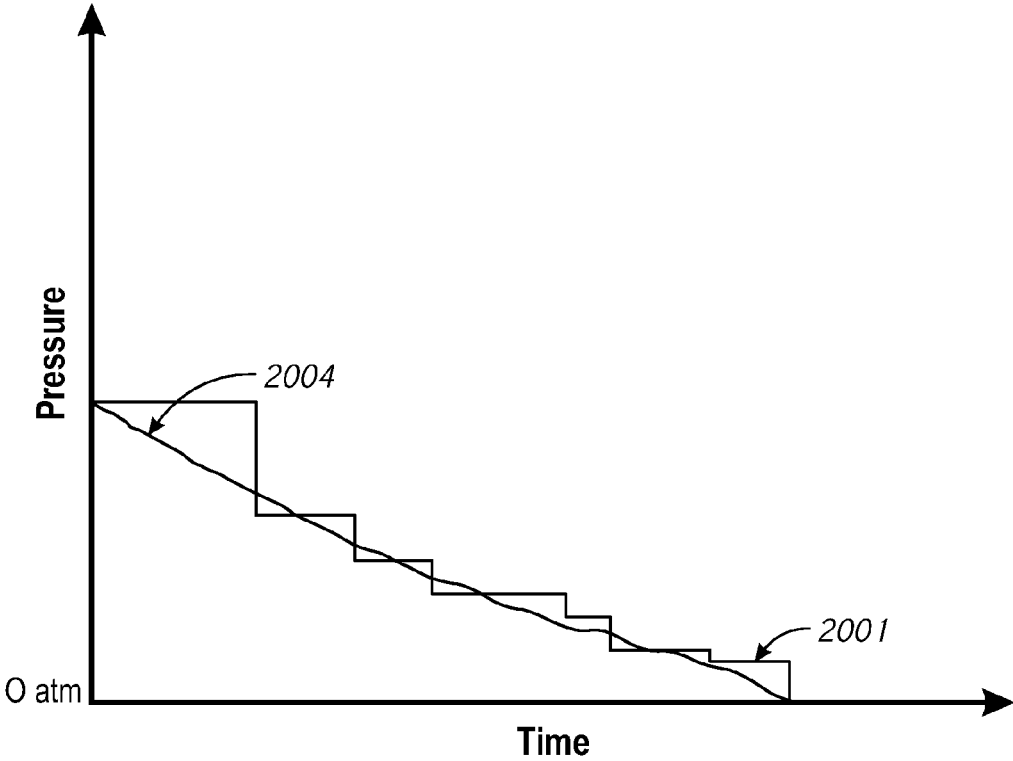

FIG. 20

SYSTEMS AND METHODS FOR APPLYING REDUCED PRESSURE THERAPY

CROSS-REFERENCE TO RELATED APPLICATIONS

[0001] This application claims the benefit of U.S. Provisional Application No. 61/785,384, filed Mar. 14, 2013, and U.S. Provisional Application No. 61/860,809, filed Jul. 31, 2013, the disclosures of which are hereby incorporated by reference in their entireties.

BACKGROUND

[0002] Embodiments of the present disclosure relate to methods and apparatuses for dressing and treating a wound with reduced pressure therapy or topical negative pressure (TNP) therapy. In particular, but without limitation, embodiments disclosed herein relate to negative pressure therapy devices, methods for controlling the operation of TNP systems, and method of using TNP systems. In addition, embodiments disclosed herein relate to attachment mechanisms or systems for negative pressure therapy devices.

SUMMARY

[0003] In some embodiments, an apparatus for applying negative pressure therapy to a wound includes a source of negative pressure configured to be coupled to a dressing, a first controller configured to perform a first set of tasks, and a second controller in communication with the first controller, the second controller configured to perform a second set of tasks. The first set of tasks can be associated with a first risk level and a second set of tasks can be associated with a second risk level different from the first risk level. The first set of tasks performed by the first controller can include processing input received from a user and providing data to be output to the user, wherein input received from the user can include negative pressure therapy parameters. The second set of tasks performed by the second controller can include operating the source of negative pressure in accordance with the negative pressure therapy parameters. Processing input received from the user can be associated with a first level of responsiveness and operating the source of negative pressure can be associated with a second level of responsiveness, the second level of responsiveness exceeding the first level of responsiveness.

[0004] The apparatus of the preceding paragraph may also include any combination of the following features described in this paragraph, among others described herein. The apparatus can include a third controller in communication with the first controller, the third controller configured to perform a third set of tasks associated with a third risk level different from the first and second risk levels. The third set of tasks performed by the third controller can include communicating data to a remote computing device and communicating data to the remote computing device can be associated with a third level of responsiveness, the third level of responsiveness being different from the first and second levels of responsiveness. The apparatus can include a dressing configured to be placed over the wound and to create a substantially fluid impermeable seal over the wound.

[0005] In certain embodiments, an apparatus for applying negative pressure therapy to a wound includes a source of negative pressure configured to be coupled to a dressing, the source of negative pressure configured to aspirate fluid from the wound, a canister configured to collect fluid aspirated

from the wound, a fluid flow path configured to fluidically connect the dressing, canister, and source of negative pressure, and a flow restrictor configured to be placed in the fluid flow path. The apparatus can also include first and second pressure sensors configured to measure pressure downstream of the flow restrictor, the second pressure sensor configured to operate as a backup pressure sensor to the first pressure sensor, a third pressure sensor configured to measure pressure upstream of the flow restrictor, and a controller configured to indicate, based at least in part on the pressure measurements received from the first, second, and third pressure sensors, at least one of a leakage, blockage, and overpressure in the fluid flow path.

[0006] In various embodiments, an apparatus for applying negative pressure therapy to a wound, includes a source of negative pressure configured to be fluidically connected to a dressing configured to be placed over a wound, the source of negative pressure configured to deliver negative pressure wound therapy to the wound in accordance with a plurality negative pressure therapy parameters. The apparatus can also include a controller configured to provide a graphical user interface (GUI) configured to permit adjustment of at least some of the plurality of negative pressure therapy parameters, receive, via the GUI, a first adjustment of a first negative pressure therapy parameter, adjust or cause adjustment of operation of the source of negative pressure based at least in part on the first adjustment of the first negative pressure therapy parameter, record a plurality of historical data parameters associated with the plurality of negative pressure therapy parameters, wherein at least one historical data parameter is associated with first and second settings of a negative therapy pressure therapy parameter, the first and second settings assigned to the negative pressure therapy parameter at different times, and transmit or cause transmission over a communication interface at least some of the plurality of historical data parameters to a remote computer.

[0007] The apparatus of any of preceding paragraphs may also include any combination of the following features described in this paragraph, among others described herein. At least some of the plurality of historical data parameters transmitted to the remote computer can include one or more of apparatus identification data, apparatus location data, therapy history data, and alarm data. The controller can also be configured to record or cause recording of apparatus location data corresponding to a geographical location of the apparatus. The controller can also be configured to record or cause recording of apparatus location data based on at least one of global positioning data (GPS) and cellular network data. The controller can also be configured to periodically transmit or cause periodic transmission over the communication interface of the at least some of the plurality of historical data parameters to the remote computer. The controller can also be configured to receive, via the GUI, a request to transmit the at least some of the plurality of historical data parameters to the remote computer and transmit or cause transmission of the at least some of plurality of historical data parameters to the remote computer. The controller can also be configured to determine or cause determination of a flow rate in a fluid flow path, the fluid flow path including the source of negative pressure and the dressing and provide, via the GUI, an indication of the determined flow rate. The indication of the flow rate can include a gauge.

[0008] The apparatus of any of preceding paragraphs may also include any combination of the following features

described in this paragraph, among others described herein. The apparatus can include a pressure sensor configured to measure pressure in at least a portion of the fluid flow path, and the controller can also be configured to determine or cause determination of the flow rate in the fluid flow path based at least in part on pressure measured by the pressure sensor. The source of negative pressure can a vacuum pump and the controller is can also be configured to determine or cause determination of the flow rate in the fluid flow path based at least in part on a measured speed of the vacuum pump. The controller can also be configured to deactivate or cause deactivation of the source of negative pressure in response to determining that the flow rate satisfies a high flow threshold and provide, via the GUI, a high flow indication. The provided high flow indication can also include information for resolving the high flow condition.

[0009] The apparatus of any of preceding paragraphs may also include any combination of the following features described in this paragraph, among others described herein. The controller can also be configured to chronologically display, via the GUI, at least some of the historical data parameters associated with the plurality of negative pressure therapy parameters. At least some of the historical data parameters can include one or more errors associated with delivery of negative pressure wound therapy. The controller can also be configured to provide, via the GUI, a log including total negative pressure wound therapy time delivered over a plurality of time periods and one or more errors can be included in the log. The controller can also be configured to in response to transmitting or causing transmission of the at least some of the plurality of historical data parameters, receive or cause receiving from the remote computer of a second adjustment of a second negative pressure therapy parameter and adjust or cause adjustment of operation of the source of negative pressure based at least in part on the received second adjustment of the second negative pressure therapy parameter. The controller can also be configured to permit, via the GUI, adjustment of the second negative pressure therapy parameter.

[0010] The apparatus of any of preceding paragraphs may also include any combination of the following features described in this paragraph, among others described herein. The apparatus can include a touch screen display configured to display the GUI and permit adjustment of at least some of the plurality of negative pressure therapy parameters. The apparatus can be configured to treat two wounds with negative pressure wound therapy and the processor can also be configured to, via the GUI, permit activation of treatment of two wounds. The GUI can be configured to include a plurality of screens and a plurality of icons grouped into a menu and the menu can be configured to be displayed in the same portion of each screen.

[0011] In some embodiments, a negative pressure wound therapy apparatus includes a source of negative pressure configured to be fluidically connected to a dressing configured to be placed over a wound and a controller. The controller can be configured to detect or cause detection of presence of at least one temporary blockage in a fluid flow path including the source of negative pressure, a canister configured to store fluid aspirated from the wound, and the dressing, the at least one temporary blockage caused by fluid aspirated from the wound being aspirated into the canister. The controller can also be configured to clear or cause clearance of the at least

one temporary blockage by increasing a level of negative pressure provided by the source of negative pressure.

[0012] The apparatus of any of preceding paragraphs may also include any combination of the following features described in this paragraph, among others described herein. The controller can also be configured to detect or cause detection of presence of the at least one temporary blockage in the fluid flow path by deactivating or causing deactivation of the source of negative pressure and detecting or causing detection of a substantially discontinuous decay of negative pressure in the fluid flow path while the source of negative pressure is deactivated. The apparatus can also include a pressure sensor configured to measure pressure at a canister inlet and the controller can also be configured to detect or cause detection of presence of the at least one temporary blockage by detecting an increase in pressure measured by the pressure sensor, the increase in pressure caused by the at least one temporary blockage.

[0013] In certain embodiments, a computer system includes at least one processor configured to receive, over a communication interface, a plurality of operational parameters from a plurality of negative pressure wound therapy devices, each negative pressure wound therapy device configured to provide negative pressure wound therapy, group at least some of the plurality of negative pressure wound therapy devices into a fleet, and provide at least some of the plurality of received operational parameters for at least some of the devices in the fleet based on a common ownership or common leasing status.

[0014] The computer system of the preceding paragraph may also include any combination of the following features described in this paragraph, among others described herein. The processor can also be configured to provide at least one of geographical location data, battery charge data, and battery life data for at least some of the devices in the fleet. The processor can also be configured to receive an adjustment of at least one operational parameter associated with at least one device in the fleet and transmit the received adjustment thereby causing the at least one device to modify delivery of negative pressure wound therapy in accordance with the adjustment.

[0015] In various embodiments, an attachment system for mounting an apparatus includes a cradle configured to be removably attached to the apparatus, a first arm attached to the cradle and a second arm, the second arm configured to be moved between a clamped position and an unclamped position, wherein the first and second arms are configured to be substantially securely attached to a structure in the clamped position, and wherein the first and second arms are configured to not be substantially securely attached to the structure in the unclamped position. The attachment system also includes a first screw, a second screw attached to the second arm, the first screw engaged with the second screw, and a knob attached to the second screw, the knob configured to move the second arm between the clamped and unclamped positions.

[0016] The attachment system of the preceding paragraph may also include any combination of the following features described in this paragraph, among others described herein. The first and second screws can be power screws. The first screw can include a first thread and the second screw can include a second thread, wherein the first and second threads can be Acme threads. The first screw includes a substantially hollow portion and at least a part of the second screw is configured to be positioned in the interior portion of the first

screw in the clamped position. The interior portion of the first screw can include an interior thread configured to engage with the second thread of the second screw. The first screw can include a first thread oriented in a first direction and the second screw can include a second thread oriented in a second direction opposite from the first direction. Rotation of the handle can cause the second arm to move a distance proportional to an aggregate of a first lead of the first screw and a second lead of the second screw. The second arm can also be configured to be moved between a fully open and a fully closed position, the first and second arms being in contact in the fully closed position, and the first and second arms being separated by a distance in the fully open position, whereby about four rotations of the knob cause the second arm to move between the fully closed and fully open positions.

[0017] The attachment system of any of preceding paragraphs may also include any combination of the following features described in this paragraph, among others described herein. The structure can be at least one of a pole and a bedrail. The negative pressure source can be configured to be fluidically connected to a dressing configured to be placed over a wound and to create a substantially fluid impermeable seal over the wound. The apparatus can include a pump. The pump can be a negative pressure wound therapy (NPWT) apparatus. In certain embodiments, the attachment system of any of preceding paragraphs can be used in a method of attaching a negative pressure wound therapy (NPWT) apparatus to a structure.

[0018] In some embodiments, an attachment system for mounting an apparatus includes a cradle configured to be removably attached to the apparatus, a first clamp arm attached to the cradle and a second clamp arm, the second clamp arm configured to be moved between a clamped position and an unclamped position, wherein the first and second clamp arms are configured to be substantially securely attached to a structure in the clamped position, a first screw engaged with a second screw, the first screw including a first thread oriented in an opposite direction from a second thread of the second screw, and the second screw configured to move the second arm between the clamped and unclamped positions.

[0019] The attachment system of any of preceding paragraphs may also include any combination of the following features described in this paragraph, among others described herein. The apparatus can be a pump. The pump can be a negative pressure wound therapy (NPWT) apparatus. In certain embodiments, the attachment system of any of preceding paragraphs can be used in a method of attaching a negative pressure wound therapy (NPWT) apparatus to a structure.

[0020] In certain embodiments, an attachment system for mounting an apparatus includes a cradle having a first arm, a housing, and a plurality of latches configured to be removably attached to the apparatus. The attachment system also includes a second arm configured to be moved between a clamped position and an unclamped position, wherein the first and second arms are configured to be substantially securely attached to a structure in the clamped position, and wherein the first and second arms are configured to not be substantially securely attached to the structure in the unclamped position. The attachments system also includes a first screw positioned at least partly within the housing of the cradle, the first screw including a first thread oriented in a first direction and a second screw including a second thread oriented in a second direction, the second screw positioned at

least partly within the housing of the cradle, the second screw attached to the second arm via an opening in the second arm, the opening including a first interior thread configured to engage with the second thread of the second screw. The second screw includes a substantially hollow interior portion having a second interior thread configured to engage with the first thread of the first screw so that at least a part of the first screw is configured to be positioned in the interior of the second screw in the clamped position. The attachment system also includes a knob attached to the second screw, the knob configured to move the second arm between the clamped and unclamped positions.

[0021] The attachment system of any of preceding paragraphs may also include any combination of the following features described in this paragraph, among others described herein. The apparatus can be a pump. The pump can be a negative pressure wound therapy (NPWT) apparatus. In certain embodiments, the attachment system of any of preceding paragraphs can be used in a method of attaching a negative pressure wound therapy (NPWT) apparatus to a structure.

[0022] In various embodiments, a method of operating a negative pressure wound therapy apparatus includes operating a source of negative pressure configured to be fluidically connected to a dressing configured to be placed over a wound, the source of negative pressure configured to deliver negative pressure wound therapy to the wound in accordance with a plurality negative pressure therapy parameters. The method also includes operating a graphical user interface (GUI) configured to permit adjustment of at least some of the plurality of negative pressure therapy parameters and providing, via the GUI, a first adjustment of a first negative pressure therapy parameter thereby causing adjustment of operation of the source of negative pressure based at least in part on the first adjustment of the first negative pressure therapy parameter. The apparatus is configured to record a plurality of historical data parameters associated with the plurality of negative pressure therapy parameters and is further configured to transmit over a communication interface at least some of the plurality of historical data parameters to a remote computer. At least one historical data parameter is associated with first and second settings of a negative pressure therapy parameter, the first and second settings assigned to the negative pressure therapy parameter at different times.

[0023] The method of the preceding paragraph may also include any combination of the following features described in this paragraph, among others described herein. At least some of the plurality of historical data parameters transmitted to the remote computer can include one or more of apparatus identification data, apparatus location data, therapy history data, and alarm data. The apparatus can also be configured to record apparatus location data corresponding to a geographical location of the apparatus. The apparatus can also be configured to record apparatus location data based on at least one of global positioning data (GPS) and cellular network data. The apparatus can also be configured to periodically transmit over the communication interface of the at least some of the plurality of historical data parameters to the remote computer. The method can also include providing, via the GUI, a request to transmit the at least some of the plurality of historical data parameters to the remote computer thereby causing transmission of the at least some of plurality of historical data parameters to the remote computer. The apparatus can also be configured to determine a flow rate in a fluid flow path, the fluid flow path comprising the source of negative pressure and the

dressing and provide, via the GUI, an indication of the determined flow rate. The indication of the flow rate can include a gauge. The apparatus can also include a pressure sensor configured to measure pressure in at least a portion of the fluid flow path and the apparatus can also be configured to determine the flow rate in the fluid flow path based at least in part on pressure measured by the pressure sensor.

[0024] The method of any of preceding paragraphs may also include any combination of the following features described in this paragraph, among others described herein. The source of negative pressure can include a vacuum pump and the apparatus can be also configured to determine the flow rate in the fluid flow path based at least in part on a measured speed of the vacuum pump. The apparatus can also be configured to deactivate the source of negative pressure in response to determining that the flow rate satisfies a high flow threshold and provide, via the GUI, a high flow indication. The provided high flow indication can include information for resolving the high flow condition. The GUI can be configured to chronologically display at least some of the historical data parameters associated with the plurality of negative pressure therapy parameters. At least some of the historical data parameters can include one or more errors associated with delivery of negative pressure wound therapy. The GUI can be configured to display a log comprising total negative pressure wound therapy time delivered over a plurality of time periods and one or more errors can be included in the log.

[0025] The method of any of preceding paragraphs may also include any combination of the following features described in this paragraph, among others described herein. The apparatus can also be configured to in response to transmitting the at least some of the plurality of historical data parameters, receive from the remote computer a second adjustment of a second negative pressure therapy parameter and adjust operation of the source of negative pressure based at least in part on the received second adjustment of the second negative pressure therapy parameter. The GUI can be configured to permit adjustment of the second negative pressure therapy parameter. The apparatus can include a touch screen display configured to display the GUI. The apparatus can be configured to treat two wounds with negative pressure wound therapy and the GUI can be configured to permit activation of treatment of two wounds. The GUI can be configured to include a plurality of screens and a plurality of icons grouped into a menu and the menu can be configured to be displayed in the same portion of each screen.

[0026] In certain embodiments, a method of operating a negative pressure wound therapy apparatus includes operating a source of negative pressure configured to be fluidically connected to a dressing configured to be placed over a wound, the source of negative pressure configured to deliver negative pressure wound therapy to the wound. The apparatus is configured to detect presence of at least one temporary blockage in a fluid flow path comprising the source of negative pressure, a canister configured to store fluid aspirated from the wound, and the dressing, the at least one temporary blockage caused by fluid aspirated from the wound being aspirated into the canister and clear the at least one temporary blockage by increasing a level of negative pressure provided by the source of negative pressure.

[0027] The method of any of preceding paragraphs may also include any combination of the following features described in this paragraph, among others described herein. The apparatus can also be configured to detect presence of the

at least one temporary blockage in the fluid flow path by deactivating the source of negative pressure and detecting substantially discontinuous decay of negative pressure in the fluid flow path while the source of negative pressure is deactivated. The apparatus can also include a pressure sensor configured to measure pressure at a canister inlet and the apparatus can also be configured to detect presence of the at least one temporary blockage by detecting an increase in pressure measured by the pressure sensor, the increase in pressure caused by the at least one temporary blockage.

[0028] In some embodiments, a method of managing a plurality of negative pressure wound therapy devices includes receiving, over a communication interface, a plurality of operational parameters from the plurality of negative pressure wound therapy devices, each negative pressure wound therapy device configured to provide negative pressure wound therapy, grouping at least some of the plurality of negative pressure wound therapy devices into a fleet and providing at least some of the plurality of received operational parameters for at least some of the devices in the fleet based on a common ownership or common leasing status. The method can be performed by a processor.

[0029] The method of any of preceding paragraphs may also include any combination of the following features described in this paragraph, among others described herein. The method can also include providing at least one of geographical location data, battery charge data, and battery life data for at least some of the devices in the fleet. The method can also include receiving an adjustment of at least one operational parameter associated with at least one device in the fleet and transmitting the received adjustment thereby causing the at least one device to modify delivery of negative pressure wound therapy in accordance with the adjustment.

[0030] In various embodiments, a negative pressure wound therapy device includes a housing having a protrusion formed in an exterior of the housing and a mount configured to be attached to the protrusion, the mount including a first portion and a second portion. The first portion includes a first circular opening, the first opening having a diameter larger than a diameter of the protrusion, and a second elongated opening extending from the first opening, the second opening having a width that is substantially same as the diameter of the protrusion. The second portion includes a rod configured to permit attachment of a carry strap. The mount is configured to be attached to the device by coupling the mount to the protrusion in a region of the second elongated opening.

BRIEF DESCRIPTION OF THE DRAWINGS

[0031] Embodiments of the present invention will now be described hereinafter, by way of example only, with reference to the accompanying drawings in which:

[0032] FIG. 1 illustrates a reduced pressure wound therapy system according to some embodiments.

[0033] FIGS. 2A-2F illustrate a pump assembly and canister according to some embodiments.

[0034] FIGS. 3A-3G illustrate a pump assembly according to some embodiments.

[0035] FIGS. 4A-4G illustrate a canister according to some embodiments.

[0036] FIGS. 5A-5C illustrate a kickstand in operation according to some embodiments.

[0037] FIGS. 6A-6F illustrate a canister according to some embodiments.

[0038] FIGS. 7A-7E illustrate a canister according to various embodiments.

[0039] FIGS. 8A-8G illustrate a pump assembly and canister according to certain embodiments.

[0040] FIGS. 9A-9C illustrate a canister bulkhead according to some embodiments.

[0041] FIG. 10 illustrates a canister filter stack according to some embodiments.

[0042] FIG. 11 illustrates a connection between a canister and pump assembly according to some embodiments.

[0043] FIG. 12 illustrates a strap mount attachment according to some embodiments.

[0044] FIGS. 13A-13B illustrate an attachment according to some embodiments.

[0045] FIG. 13C illustrates an attachment system according to some embodiments.

[0046] FIGS. 13D-13J illustrate an attachment system according to some embodiments.

[0047] FIG. 13K illustrates attachment systems in operation according to some embodiments.

[0048] FIG. 14 illustrates an electrical component schematic of a pump assembly according to some embodiments.

[0049] FIG. 15 illustrates a firmware and/or software diagram according to some embodiments.

[0050] FIGS. 16A-16S illustrate remote interface screens according to some embodiments.

[0051] FIGS. 17A-17V illustrate graphical user interface screens according to some embodiments.

[0052] FIG. 18 illustrates a process of operating a device according to some embodiments.

[0053] FIGS. 19A-19B illustrate graphs of pressure pulses according to some embodiments.

[0054] FIG. 20 illustrates a graph of vacuum level according to some embodiments.

DETAILED DESCRIPTION OF SOME EMBODIMENTS

Overview

[0055] Embodiments disclosed herein relate to systems and methods of treating a wound with reduced pressure. As is used herein, reduced or negative pressure levels, such as $-X$ mmHg, represent pressure levels relative to normal ambient atmospheric pressure, which can correspond to 760 mmHg (or 1 atm, 29.93 inHg, 101.325 kPa, 14.696 psi, etc.). Accordingly, a negative pressure value of $-X$ mmHg reflects absolute pressure that is X mmHg below 760 mmHg or, in other words, an absolute pressure of $(760-X)$ mmHg. In addition, negative pressure that is “less” or “smaller” than X mmHg corresponds to pressure that is closer to atmospheric pressure (e.g., -40 mmHg is less than -60 mmHg). Negative pressure that is “more” or “greater” than $-X$ mmHg corresponds to pressure that is further from atmospheric pressure (e.g., -80 mmHg is more than -60 mmHg). In some embodiments, local ambient atmospheric pressure is used as a reference point, and such local atmospheric pressure may not necessarily be, for example, 760 mmHg.

[0056] Embodiments of the present invention are generally applicable to use in topical negative pressure (“TNP”) or reduced or negative pressure therapy systems. Briefly, negative pressure wound therapy assists in the closure and healing of many forms of “hard to heal” wounds by reducing tissue oedema, encouraging blood flow and granular tissue formation, and/or removing excess exudate and can reduce bacte-

rial load (and thus infection risk). In addition, the therapy allows for less disturbance of a wound leading to more rapid healing. TNP therapy systems can also assist in the healing of surgically closed wounds by removing fluid. In some embodiments, TNP therapy helps to stabilize the tissue in the apposed position of closure. A further beneficial use of TNP therapy can be found in grafts and flaps where removal of excess fluid is important and close proximity of the graft to tissue is required in order to ensure tissue viability.

[0057] In some embodiments, the pump assembly can include one or more processors or controllers responsible for various system functions associated with various levels of responsiveness, such as interfacing with a user (e.g., patient, physician, nurse, etc.), controlling a negative pressure pump, providing network connectivity, and the like. In some embodiments, levels of responsiveness can correspond to or be associated with levels of risk. For example, controlling a source of negative pressure may be classified as a high risk activity, as delivery of therapy is important for patient safety, healing, etc. Accordingly, controlling the source of negative pressure can be associated with a high level of responsiveness. The pump assembly can also include one or more input/output devices for receiving and providing data. These devices can include screens, touchscreens, buttons, knobs, ports, and the like. The pump assembly can be configured to present graphical user interface (GUI) screens for controlling and monitoring the operation of the TNP system.

[0058] In some embodiments, the TNP system can be configured to determine and monitor flow of fluid in the system. This can be accomplished by using one or more pressure transducers or sensors that measure pressure in a fluid flow path and provide feedback to a controller. In various embodiments, determining of fluid flow can be accomplished by utilizing one or more of the following techniques: monitoring the speed of a pump motor, monitoring flow of fluid in a portion of a fluid flow path by placing a calibrated fluid flow restrictor, and monitoring one or more characteristics, such as amplitude, frequency, or slope of detected pressure pulses. Calculated flow rate can be used to determine whether desired therapy is delivered to a patient, whether there are one or more leaks present in the system, and the like.

[0059] In some embodiments, the system can be configured to provide indication, alarms, etc. reflecting operating conditions to a user. The system can include visual, audible, tactile, and other types of indicators and/or alarms configured to signal to the user various operating conditions. Such conditions include system on/off, standby, pause, normal operation, dressing problem, leak, error, and the like. The indicators and/or alarms can include speakers, displays, light sources, etc., and/or combinations thereof. In various embodiments, indications, alarms, etc. are guided by one or more applicable standards.

[0060] In certain embodiments, a pump assembly can include one or more communications processors for providing external connectivity. Such connectivity can be used for various activities, such as location tracking of the pump assembly, compliance monitoring, tracking of operational parameters, remote selection and adjustment of therapy settings, and the like. Connectivity can include Global Positioning System (GPS) technology, cellular connectivity (e.g., 2G, 3G, LTE, 4G), WiFi connectivity, Internet connectivity, and the like. In some embodiments, wired connectivity can be utilized. In various embodiments, the pump assembly can communicate data to a cloud and receive data from the cloud.

The data can include location data, compliance monitoring data, operational parameters, data for remote selection and adjustment of therapy settings, and the like.

[0061] Embodiments of the present invention relate to attachment systems for mounting an apparatus or device, including but not limited to a negative pressure wound therapy (“NPWT”) apparatus. In some embodiments, an attachment system includes a cradle configured to be removably attached to the apparatus. The attachment system includes a first clamp arm attached to the cradle and a second clamp arm. The second clamp arm can be configured to be moved between an unclamped position and a clamped position in which the first and second clamp arms are configured to be substantially securely attached to a structure. In the unclamped position, the first and second arms can be configured to not be attached to the structure. The structure can include any suitable structure for mounting the apparatus (e.g., medical apparatus), such as an IV pole, bedrail, and the like. The attachment system also includes a first screw engaged with a second screw which can be configured to move the second arm between the clamped and unclamped positions. The second screw can be attached to a handle. The threads of the first and second screws can be opposite pitch such that a single handle rotation provides double or substantially double linear motion as compared to using one screw. For example, in one embodiment approximately four rotations of the handle are needed to move the second clamp arm between a fully closed position in which the first and second clamp arms are not separated or substantially not separated (e.g., are in contact) and a fully open position in which the first and second clamp arms are separated by a maximum distance from each other. As a result, the attachment system can be used to efficiently and securely attach the apparatus to structures of varying thickness.

Negative Pressure System

[0062] FIG. 1 illustrates an embodiment of a negative or reduced pressure wound treatment (or TNP or NPWT) system **100** comprising a wound filler **130** placed inside a wound cavity **110**, the wound cavity sealed by a wound cover **120**. The wound filler **130** in combination with the wound cover **120** can be referred to as wound dressing. A single or multi lumen tube or conduit **140** is connected to the wound cover **120** with a pump assembly or NPWT apparatus **150** configured to supply reduced pressure. The wound cover **120** can be in fluidic communication with the wound cavity **110**. In any of the system embodiments disclosed herein, as in the embodiment illustrated in FIG. 1, the pump assembly can be a canisterless pump assembly (meaning that exudate is collected in the wound dressing or is transferred via tube **140** for collection to another location). However, any of the pump assembly embodiments disclosed herein can be configured to include or support a canister. Additionally, in any of the system embodiments disclosed herein, any of the pump assembly embodiments can be mounted to or supported by the dressing, or adjacent to the dressing. The wound filler **130** can be any suitable type, such as hydrophilic or hydrophobic foam, gauze, inflatable bag, and so on. The wound filler **130** can be conformable to the wound cavity **110** such that it substantially fills the cavity. The wound cover **120** can provide a substantially fluid impermeable seal over the wound cavity **110**. In some embodiments, the wound cover **120** has a top side and a bottom side, and the bottom side adhesively (or in any other suitable manner) seals with wound cavity **110**. The conduit

140 or any other conduit disclosed herein can be formed from polyurethane, PVC, nylon, polyethylene, silicone, or any other suitable material.

[0063] Some embodiments of the wound cover **120** can have a port (not shown) configured to receive an end of the conduit **140**. In some embodiments, the conduit **140** can otherwise pass through and/or under the wound cover **120** to supply reduced pressure to the wound cavity **110** so as to maintain a desired level of reduced pressure in the wound cavity. The conduit **140** can be any suitable article configured to provide at least a substantially sealed fluid flow pathway between the pump assembly **150** and the wound cover **120**, so as to supply the reduced pressure provided by the pump assembly **150** to wound cavity **110**.

[0064] The wound cover **120** and the wound filler **130** can be provided as a single article or an integrated single unit. In some embodiments, no wound filler is provided and the wound cover by itself may be considered the wound dressing. The wound dressing may then be connected, via the conduit **140**, to a source of negative pressure, such as the pump assembly **150**. In some embodiments, though not required, the pump assembly **150** can be miniaturized and portable, although larger conventional pumps such can also be used.

[0065] The wound cover **120** can be located over a wound site to be treated. The wound cover **120** can form a substantially sealed cavity or enclosure over the wound site. In some embodiments, the wound cover **120** can be configured to have a film having a high water vapour permeability to enable the evaporation of surplus fluid, and can have a superabsorbing material contained therein to safely absorb wound exudate. It will be appreciated that throughout this specification reference is made to a wound. In this sense it is to be understood that the term wound is to be broadly construed and encompasses open and closed wounds in which skin is torn, cut or punctured or where trauma causes a contusion, or any other surficial or other conditions or imperfections on the skin of a patient or otherwise that benefit from reduced pressure treatment. A wound is thus broadly defined as any damaged region of tissue where fluid may or may not be produced. Examples of such wounds include, but are not limited to, acute wounds, chronic wounds, surgical incisions and other incisions, subacute and dehisced wounds, traumatic wounds, flaps and skin grafts, lacerations, abrasions, contusions, burns, diabetic ulcers, pressure ulcers, stoma, surgical wounds, trauma and venous ulcers or the like. In some embodiments, the components of the TNP system described herein can be particularly suited for incisional wounds that exude a small amount of wound exudate.

[0066] Some embodiments of the system are designed to operate without the use of an exudate canister. Some embodiments can be configured to support an exudate canister. In some embodiments, configuring the pump assembly **150** and tubing **140** so that the tubing **140** can be quickly and easily removed from the pump assembly **150** can facilitate or improve the process of dressing or pump changes, if necessary. Any of the pump embodiments disclosed herein can be configured to have any suitable connection between the tubing and the pump.

[0067] In some embodiments, the pump assembly **150** can be configured to deliver negative pressure of approximately -80 mmHg, or between about -20 mmHg and -200 mmHg. Note that these pressures are relative to normal ambient atmospheric pressure thus, -200 mmHg would be about 560 mmHg in practical terms. In some embodiments, the pressure

range can be between about -40 mmHg and -150 mmHg. Alternatively a pressure range of up to -75 mmHg, up to -80 mmHg or over -80 mmHg can be used. Also in other embodiments a pressure range of below -75 mmHg can be used. Alternatively a pressure range of over approximately -100 mmHg, or even -150 mmHg, can be supplied by the pump assembly **150**.

[0068] In some embodiments, the pump assembly **150** is configured to provide continuous or intermittent negative pressure therapy. Continuous therapy can be delivered at above -25 mmHg, -25 mmHg, -40 mmHg, -50 mmHg, -60 mmHg, -70 mmHg, -80 mmHg, -90 mmHg, -100 mmHg, -120 mmHg, -140 mmHg, -160 mmHg, -180 mmHg, -200 mmHg, or below -200 mmHg. Intermittent therapy can be delivered between low and high negative pressure set points. Low set point can be set at above 0 mmHg, 0 mmHg, -25 mmHg, -40 mmHg, -50 mmHg, -60 mmHg, -70 mmHg, -80 mmHg, -90 mmHg, -100 mmHg, -120 mmHg, -140 mmHg, -160 mmHg, -180 mmHg, or below -180 mmHg. High set point can be set at above -25 mmHg, -40 mmHg, -50 mmHg, -60 mmHg, -70 mmHg, -80 mmHg, -90 mmHg, -100 mmHg, -120 mmHg, -140 mmHg, -160 mmHg, -180 mmHg, -200 mmHg, or below -200 mmHg. During intermittent therapy, negative pressure at low set point can be delivered for a first time duration, and upon expiration of the first time duration, negative pressure at high set point can be delivered for a second time duration. Upon expiration of the second time duration, negative pressure at low set point can be delivered. The first and second time durations can be same or different values. The first and second durations can be selected from the following range: less than 2 minutes, 2 minutes, 3 minutes, 4 minutes, 6 minutes, 8 minutes, 10 minutes, or greater than 10 minutes. In some embodiments, switching between low and high set points and vice versa can be performed according to a step waveform, square waveform, sinusoidal waveform, and the like.

[0069] In operation, the wound filler **130** is inserted into the wound cavity **110** and wound cover **120** is placed so as to seal the wound cavity **110**. The pump assembly **150** provides a source of a negative pressure to the wound cover **120**, which is transmitted to the wound cavity **110** via the wound filler **130**. Fluid (e.g., wound exudate) is drawn through the conduit **140**, and can be stored in a canister. In some embodiments, fluid is absorbed by the wound filler **130** or one or more absorbent layers (not shown).

[0070] Wound dressings that may be utilized with the pump assembly and other embodiments of the present application include Renasys-F, Renasys-G, Renasys AB, and Pico Dressings available from Smith & Nephew. Further description of such wound dressings and other components of a negative pressure wound therapy system that may be used with the pump assembly and other embodiments of the present application are found in U.S. Patent Publication Nos. 2012/0116334, 2011/0213287, 2011/0282309, 2012/0136325 and 2013/0110058, which are incorporated by reference in their entirety. In other embodiments, other suitable wound dressings can be utilized.

Pump Assembly and Canister

[0071] FIG. 2A illustrates a front view **200A** of a pump assembly **230** and canister **220** according to some embodiments. As is illustrated, the pump assembly **230** and the canister are connected, thereby forming a device (or NPWT apparatus). The pump assembly **230** comprises one or more

indicators, such as visual indicator **202** configured to indicate alarms and visual indicator **204** configured to indicate status of the TNP system. The indicators **202** and **204** can be configured to alert a user to a variety of operating and/or failure conditions of the system, including alerting the user to normal or proper operating conditions, pump failure, power supplied to the pump or power failure, detection of a leak within the wound cover or flow pathway, suction blockage, or any other similar or suitable conditions or combinations thereof. In some embodiments, the pump assembly **230** can comprise additional indicators. In some embodiments, a single indicator is used. In other embodiments, multiple indicators are used. Any suitable indicator can be used such as visual, audio, tactile indicator, and so on. The indicator **202** can be configured to signal alarm conditions, such as canister full, power low, conduit **140** disconnected, seal broken in the wound seal **120**, and so on. The indicator **202** can be configured to display red flashing light to draw user's attention. The indicator **204** can be configured to signal status of the TNP system, such as therapy delivery is ok, leak detected, and so on. The indicator **204** can be configured to display one or more different colors of light, such as green, yellow, etc. For example, green light can be emitted when the TNP system is operating properly and yellow light can be emitted to indicate a warning.

[0072] The pump assembly **230** comprises a display or screen **206** mounted in a recess **208** formed in a case of the pump assembly. In some embodiments, the display **206** can be a touch screen display. In some embodiments, the display **206** can support playback of audiovisual (AV) content, such as instructional videos. As explained below, the display **206** can be configured to render a number of screens or graphical user interfaces (GUIs) for configuring, controlling, and monitoring the operation of the TNP system. The pump assembly **230** comprises a gripping portion **210** formed in the case of the pump assembly. The gripping portion **210** can be configured to assist the user to hold the pump assembly **230**, such as during removal of the canister **220**. In some embodiments, the canister **220** can be replaced with another canister, such as when the canister **220** has been filled with fluid.

[0073] The pump assembly **230** comprises one or more keys or buttons **212** configured to allow the user to operate and monitor the operation of the TNP system. As is illustrated, in some embodiments, there buttons **212a**, **212b**, and **212c** are included. Button **212a** can be configured as a power button to turn on/off the pump assembly **230**. Button **212b** can be configured as a play/pause button for the delivery of negative pressure therapy. For example, pressing the button **212b** can cause therapy to start, and pressing the button **212b** afterward can cause therapy to pause or end. Button **212c** can be configured to lock the display **206** and/or the buttons **212**. For instance, button **212c** can be pressed so that the user does not unintentionally alter the delivery of the therapy. Button **212c** can be depressed to unlock the controls. In other embodiments, additional buttons can be used or one or more of the illustrated buttons **212a**, **212b**, or **212c** can be omitted. In some embodiments, multiple key presses and/or sequences of key presses can be used to operate the pump assembly **230**.

[0074] The pump assembly **230** includes one or more latch recesses **222** formed in the cover. In the illustrated embodiment, two latch recesses **222** can be formed on the sides of the pump assembly **230**. The latch recesses **222** can be configured to allow attachment and detachment of the canister **220** using one or more canister latches **221**. The pump assembly **230** comprises an air outlet **224** for allowing air removed from the

wound cavity 110 to escape. Air entering the pump assembly can be passed through one or more suitable filters (described below, such as in FIG. 10), such as antibacterial filters. This can maintain reusability of the pump assembly. The pump assembly 230 includes one or more mounts 226 for connecting a carry strap to the pump assembly 230 or for attaching a cradle. In the illustrated embodiment, two mounts 226 can be formed on the sides of the pump assembly 230. In some embodiments, various of these features are omitted and/or various additional features are added to the pump assembly 230.

[0075] The canister 220 is configured to hold fluid (e.g., exudate) removed from the wound cavity 110. The canister 220 includes one or more latches 221 for attaching the canister to the pump assembly 230. In the illustrated embodiment, the canister 220 comprises two latches 221 on the sides of the canister. The exterior of the canister 220 can be formed from frosted plastic so that the canister is substantially opaque and the contents of the canister are substantially hidden from plain view. The canister 220 comprises a gripping portion 214 formed in a case of the canister. The gripping portion 214 can be configured to allow the user to hold the pump assembly 220, such as during removal of the canister from the apparatus 230. The canister 220 includes a substantially transparent window 216, which can also include graduations of volume. For example, the illustrated 300 mL canister 220 includes graduations of 50 mL, 100 mL, 150 mL, 200 mL, 250 mL, and 300 mL. Other embodiments of the canister can hold different volume of fluid and can include different graduation scale. The canister 220 comprises a tubing channel 218 for connecting to the conduit 140. In some embodiments, various of these features, such as the gripping portion 214, are omitted and/or various additional features are added to the canister 220.

[0076] FIG. 2B illustrates a rear view 200B of the pump assembly 230 and canister 220 according to some embodiments. The pump assembly 230 comprises a speaker port 232 for producing and/or radiating sound. The pump assembly 230 includes a filter access door 234 for accessing and replacing one or more filters, such as odor filter, antibacterial filters, etc. In one embodiment, the access door 234 can be used to access a chamber (such as a plenum chamber) in which noise suppressing or sound absorbing material is placed. The chamber and sound absorbing material can be part of a silencing system that is used to suppress or absorb noise generated by the source of negative pressure. Sound absorbing material can serve to break up sound waves as travel (or reverberate) through the chamber. Sound absorbing material can further function as an odor suppressant. In one embodiment, for example, sound absorbing material can be impregnated with activated charcoal for odor suppression. The access door 234 can further include a seal (such as a sealing gasket) for tight closure of the chamber. Additional details of the silencing system are described in U.S. Patent Publication No. 2010/0185165, which is incorporated by reference in its entirety.

[0077] The pump assembly 230 comprises a gripping portion 236 formed in the case of the pump assembly. As is illustrated, the gripping portion 236 is a recess formed in the outer casing of the pump assembly 230. In some embodiments, the gripping portion 236 may include rubber, silicone, etc. coating. The gripping portion 236 can be configured (e.g., positioned and dimensioned) to allow the user to firmly hold the pump assembly 230, such as during removal of the canister 220. The pump assembly 230 includes one or more

covers 238 configured as screw covers and/or feet or protectors for placing the pump assembly 230 on a surface. The covers 230 can be formed out of rubber, silicone, or any other suitable material. The pump assembly 230 comprises a power jack 239 for charging and recharging an internal battery of the pump assembly. In some embodiments, the power jack 239 is a direct current (DC) jack. In some embodiments, the pump assembly can comprise a disposable power source, such as batteries, so that no power jack is needed.

[0078] The canister 220 includes one or more feet 244 for placing the canister on a surface. The feet 244 can be formed out of rubber, silicone, or any other suitable material and can be angled at a suitable angle so that the canister 220 remains stable when placed on the surface. The canister 220 comprises a tube mount relief 246 configured to allow one or more tubes to exit to the front of the device. The canister 220 includes a stand or kickstand 248 for supporting the canister when it is placed on a surface. As explained below, the kickstand 248 can pivot between an opened and closed position. In closed position, the kickstand 248 can be latched to the canister 220. In some embodiments, the kickstand 248 can be made out of opaque material, such as plastic. In other embodiments, the kickstand 248 can be made out of transparent material. The kickstand 248 includes a gripping portion 242 formed in the kickstand. The gripping portion 242 can be configured to allow the user to place the kickstand 248 in the closed position. The kickstand 248 comprises a hole 249 to allow the user to place the kickstand in the open position. The hole 249 can be sized to allow the user to extend the kickstand using a finger.

[0079] FIG. 2C illustrates a view 200C of the pump assembly 230 separated from the canister 220 according to some embodiments. The pump assembly 230 includes a vacuum attachment or connector 252 through which a vacuum pump communicates negative pressure to the canister 220. The pump assembly 230 comprises a USB access door 256 configured to allow access to one or more USB ports. In some embodiments, the USB access door is omitted and USB ports are accessed through the door 234. The pump assembly 230 can include additional access doors configured to allow access to additional serial, parallel, and/or hybrid data transfer interfaces, such as SD, Compact Disc (CD), DVD, FireWire, Thunderbolt, PCI Express, and the like. In other embodiments, one or more of these additional ports are accessed through the door 234.

[0080] FIG. 2D illustrates a schematic front view 230D and rear view 230D' of a pump assembly 200D according to some embodiments.

[0081] FIG. 2E illustrates a view 200E of the interior components of the pump assembly 230 according to some embodiments. The pump assembly 230 can include various components, such as a canister connector 252 which includes a sealing ring 253, control printed circuit board (PCB) 260, peripherals PCB 262 (e.g., for USB connectivity), power supply PCB 264, vacuum pump 266, power supply 268 (e.g., rechargeable battery), speaker 270, and light guide or pipe 272 (e.g., for status indication using guided light emitted by one or more LEDs). Further details of status indication are provided in U.S. Pat. No. 8,294,586, which is assigned to the assignee of the present application and is incorporated by reference in its entirety. Other components can be included, such as electrical cables, connectors, tubing, valves, filters,

fasteners, screws, holders, and so on. In some embodiments, the pump assembly 230 can comprise alternative or additional components.

[0082] FIG. 2F illustrates another view 200F of the interior components of the pump assembly 230 according to some embodiments. As is explained below, the pump assembly 230 includes an antenna 276. The connector 252 between the vacuum pump 266 and the canister 220 includes a flow restrictor 278. As is explained below, the flow restrictor 278 can be a calibrated flow restrictor used for measuring flow in the fluid flow path and for determining various operating conditions, such as leaks, blockages, high pressure (over-vacuum), and the like. In some embodiments, flow across the restrictor 278 can be determined by measuring a pressure differential (or pressure drop) across the flow restrictor. In various embodiments, flow across the restrictor 278 can be characterized as high flow (e.g., due to a leak), low flow (e.g., due to a blockage or canister being full), normal flow, etc. As is illustrated, pressure sensor 284 measures pressure upstream (or on the canister side) of the flow restrictor 278. Pressure sensor 284 can be an electronic pressure sensor mounted on the control PCB 264. Conduit or lumen 286 can connect the upstream side of the flow restrictor 278 with the pressure sensor 284. Pressure sensors 280 and 282 measure pressure downstream (or on the vacuum pump side) of the flow restrictor 278. Pressure sensors 280 and 282 can be electronic pressure sensors mounted on the control PCB 264. Conduit or lumen 288 can connect the downstream side of the flow restrictor 278 with the pressure sensors 280 and 284 via a Y-connector 289.

[0083] In some embodiments, one of pressure sensors 280 and 282 can be designated as a primary pressure sensor and the other as a backup pressure sensor in case the primary pressure sensor becomes defective or inoperative. For example, pressure sensor 280 can be the primary pressure sensor and pressure sensor 282 can be the backup pressure sensor. Pressure drop across the flow restrictor 278 can be determined by subtracting pressure measured by sensor 280 and sensor 284. If pressure sensor 280 fails, pressure drop across the flow restrictor can be determined by subtracting pressure measured by sensor 282 and sensor 284. In certain embodiments, the backup pressure sensor can be used for monitoring and indicating high pressure conditions, that is when the pressure in the flow path exceeds a maximum pressure threshold. In some embodiments, one or more differential pressure sensors can be used. For example, a differential pressure sensor connected to the upstream and downstream sides of the flow restrictor 278 can measure the pressure drop across the flow restrictor. In some embodiments, one or more of these components, such as the flow restrictor 278, are omitted and/or additional components, such as one or more flow meters, are used.

[0084] FIGS. 3A-3G illustrate a pump assembly according to some embodiments. FIG. 3A-1 illustrates a perspective view 301A of the pump assembly. FIG. 3A-2 illustrates another perspective view 302A of the pump assembly. FIG. 3B illustrates a front view 300B of the pump assembly. FIG. 3C illustrates a right side view 300C of the pump assembly. FIG. 3D illustrates a rear view 300D of the pump assembly. As is illustrated, the pump assembly includes a filter enclosure 302, which can comprise a removable cover for accessing one or more filters (as illustrated in FIG. 10 and described below). FIG. 3E illustrates a top view 300E of the pump

assembly. FIG. 3F illustrates a left side view 300F of the pump assembly. FIG. 3G illustrates a bottom view 300G of the pump assembly.

[0085] FIGS. 4A-4G illustrate a canister, such as 300 mL canister, according to some embodiments. FIG. 4A-1 illustrates a perspective view 400A of the canister. FIG. 4A-2 illustrates another perspective view 401A of the canister. FIG. 4B illustrates a front view 400B of the canister. FIG. 4C illustrates a right side view 400C of the canister. FIG. 4D illustrates a rear view 400D of the canister. FIG. 4E illustrates a top view 400E of the canister. FIG. 4F illustrates a left side view 400F of the canister. FIG. 4G illustrates a bottom view 400G of the canister.

[0086] FIGS. 5A-5C illustrate a kickstand in operation according to some embodiments. FIG. 5A illustrates the kickstand 248 in an extended (or opened) position. As is illustrated, the pump assembly 230 and the canister 220 are connected or assembled together, such as by using the latches 221. The device 500A is supported on a surface by the kickstand 248 and feet 244. In the illustrated embodiment, the kickstand 248 is extended by operating one or more pivots 502. FIG. 5B illustrates positioning the device on the surface. As is illustrated in 500B, the kickstand 248 is extended and the device is placed substantially vertically on the surface and/or improve visibility of the screen 206 (e.g., by reducing glare). In 501B, the device is tilted so that it rests on the surface in a stable manner. The tilt of the device in 501B relative to 501A is illustrated by an indicator 512. In some embodiments, the tilt can be less than 30 degrees, about 30 degrees, or greater than 30 degrees. FIG. 5C illustrates the kickstand 248 that includes the hole 249 and two pivot holes 504. In some embodiments, the tilt of the device is adjustable to accommodate the needs of a user. For example, the kickstand 248 can utilize a ratchet mechanism.

[0087] FIGS. 6A-6F illustrate a canister, such as a 300 mL canister, according to some embodiments. FIG. 6A illustrates a perspective view 600A of the canister. The canister comprises a tube 140 configured to connect the canister to the wound cover 120. FIG. 6B illustrates a front view 600B of the canister. FIG. 6C illustrates a side view 600C of the canister. FIG. 6D illustrates another side view 600D of the canister. As is illustrated, the kickstand 248 is in an open position supporting the tilted canister on a surface. FIG. 6E illustrates a top view 600E of the canister. FIG. 6F illustrates a rear view 600F of the canister.

[0088] FIGS. 7A-7E illustrate a canister, such as a 800 mL canister, according to various embodiments. FIG. 7A illustrates a perspective view 700A of the canister. The canister comprises a tube 140 configured to connect the canister to the wound cover 120. The canister includes a vacuum attachment or connector 702 through which the canister receives vacuum communicated by the pump assembly 230. In some embodiments, the connector 702 is configured to be connected to or mated with the connector 252 of the pump assembly 230. FIG. 7B illustrates a front view 700B of the canister. FIG. 7C illustrates a side view 700C of the canister. FIG. 7D illustrates a top view 700D of the canister. FIG. 7E illustrates a rear view 700E of the canister. The canister comprises a clip 712 for holding the tube 140.

[0089] FIGS. 8A-8G illustrate a device according to certain embodiments. FIG. 8A illustrates a perspective view 800A of the device, which includes a pump assembly 230 and canister 220. The canister 220 can be connected to the pump assembly 230 using one or more latches 221, such as two latches 221 on

the sides of the canister **220**. FIG. **8B** illustrates a front view **800B** of the device. FIG. **8C** illustrates a right side view **800C** of the device. The device comprises a kickstand **248** that is configured to be opened or close via one or more pivots **502**. FIG. **8D** illustrates a rear view **800D** of the device. FIG. **8E** illustrates a top view **800E** of the device. FIG. **8F** illustrates a left side view **800F** of the device. The latch **221** can be configured to connect to the recess **702** formed on the pump assembly **230** in order to connect the canister **220** to the pump assembly **230**. FIG. **8G** illustrates a bottom view **800G** of the device. The canister **220** includes feet **244**.

[**0090**] FIGS. **9A-9C** illustrate a canister bulkhead **910** according to some embodiments. FIG. **9A** illustrates a top view **900A** of the canister bulkhead **910**. FIG. **9B** illustrates a perspective view **900B** of the canister bulkhead **910**. FIG. **9C** illustrates a bottom view **900C** of the canister bulkhead **910**. The canister bulkhead can be configured to connect the canister **220** to a negative pressure source of the pump assembly **230**, such as via a pump assembly bulkhead. To facilitate this function, the canister bulkhead **910** comprises a connector or port **902** which attaches to the vacuum connector **252** of the pump assembly **230**. The canister bulkhead **910** also includes a gate mark or gate **906** to facilitate connecting the canister **220** to the pump assembly **230**. The canister bulkhead **910** includes one or more regions or protrusions **904** configured to limit the capacity of the canister **220** as it fills up or when it becomes full so that the device (and the canister) can be oriented vertically, horizontally, and/or vertically tilted (e.g., when the kickstand **248** is extended). As is shown in FIGS. **9B** and **9C**, the volume of fluid held by the canister **220** is reduced or limited by the one or more protrusions **904**. In some embodiments, the device bulkhead is flat. In other embodiments, the device bulkhead can mate with the features of the canister bulkhead **910**.

[**0091**] FIG. **10** illustrates a canister filter stack **1000** according to some embodiments. The canister filter stack **1000** comprises a filter carrier **1002**, shutoff **1004**, odor filter **1006**, and antibacterial filter **1008**. The shutoff **1004** operates to stop suction when the canister **220** becomes full such that canister overflow is prevented. The shutoff can be formed out of hydrophilic material. The odor filter **1006** can comprise material that absorbs, reduces or eliminates odor. For example, such material can be active carbon, activated charcoal, or the like. The material can be hydrophobic. The antibacterial filter **1008** can inhibit or eliminate the growth of microorganisms. In some embodiments, the components of the filter stack **1000** can be arranged in any suitable order. For example, the odor filter **1006** can be integrated into the shutoff **1004** as an additive to the material of the shutoff **1004** or as a layer formed on the material of the shutoff **1004**. In some embodiments, the filter stack **1000** is placed in the canister. In some embodiments, the filter stack **1000** is placed in the connector between the canister in the pump assembly. In some embodiments, the filter stack **1000** is placed in the pump assembly.

[**0092**] FIG. **11** illustrates a connection **1104** between the canister **220** and pump assembly **230** according to some embodiments. As is illustrated, the connection **1104** is placed between the vacuum attachment **1106** of the pump assembly **230** and the attachment or port **1102** of the canister **220**. The connection **1104** can be a washer, ring, or the like which ensures a substantially leak-free seal between the canister **220** and the pump assembly **230**.

Strap

[**0093**] In some embodiments, a strap can be attached to the pump assembly **230** for carrying the device of the shoulder, waist, etc. The strap can be adjustable in length. FIG. **12** illustrates a strap mount attachment **1200** according to some embodiments. The attachment **1200** can be detachably clipped onto mounts **226** (FIG. **2B**) of the pump assembly **230**. In operation, a hole **1202** of the attachment **1200** can be aligned with the mount **226**, and a portion **1204** can be attached to the mount **226**. The inner diameter of the portion **1204** can be selected so that there is a substantially tight fit with the mount **226**. A strap (not shown) can be attached to a rod **1210**. In some embodiments, two attachments **1200** are clipped onto two mounts **226** located on the opposing sides of the pump assembly **230**.

[**0094**] In some embodiments, the device can be placed into a carrying case or carrying bag. The carrying case can be configured for accommodating the pump assembly **230** connected to the canister **220**. The carrying case can include a pouch configured to enclose the device, the pouch comprising an upper portion and a lower portion. A lower opening in the lower portion of the pouch can be configured to permit insertion of the device. The lower opening can include a closure configured to close the lower opening and to prevent the apparatus from being displaced from the pouch. The lower opening can also include an aperture (e.g., for the tube **140**) that remains open between an interior and exterior of the pouch after the closure closes the lower opening. The lower opening can comprise a flap that can be lifted to permit viewing of the canister **220**. The upper portion can also include a flap that can be lifted to permit access to the display **206** and/or buttons **212**. Additional details of the carrying bag are provided in U.S. Pat. No. 8,240,470, which is assigned to the assignee of the present application and is incorporated by reference in its entirety. In some embodiments, the pump assembly **230** and/or canister **220** includes a clip for attaching the pump assembly to a patient's belt, pocket, etc.

Attachment System

[**0095**] FIGS. **13A-13B** illustrate an attachment system **1300** according to some embodiments. In operation, the attachment system **1300** is used to mount a device or apparatus to any suitable structure, such as an IV pole (e.g., an IV pole having a diameter between 0.75 inches and 2.0 inches), a bedrail (e.g., a bedrail having a width between 0.75 inches and 3 inches), and the like. The attachment system **1300** can be used to mount to the structure any suitable device, such as a medical treatment device, including but not limited to NPWT apparatus or device. The attachment system **1300** can be configured to be adjustable so that a secure connection can be made efficiently. As is illustrated in FIG. **13A**, the attachment system **1300** includes a cradle **1310**, which attaches to the device, and a clamp **1330**. The clamp **1330** is adjustable for secure attachment to various structures. In the illustrated embodiment, the width of the clamp **1330** is adjusted by turning a knob **1334**. In some embodiments, the cradle **1310** attaches to the device by placing a mount **226** (see FIGS. **2A-2B**) into a recess **1302** and activating a closure **1318**. The closure **1318** can be a latch, lock, or any other suitable mechanism for attaching the device to the cradle **1310**. The cradle **1310** can include one or more closures **1318**, such as two closures on each side of the cradle.

[0096] The attachment system **1300** attaches to a structure, such as a pole, rail, or the like by turning the knob **1334** so that a portion of the structure is secured in the space between the first and second clamp arms as described below. The device can be removed from the cradle **1310** by deactivating the one or more closures **1318**. For example, the one or more closures **1318** can be released or unlocked (e.g., by pressing) to allow detachment of the device from the cradle **1310**. The attachment system **1300** is configured to be attached to structures of various thickness. For example, the attachment system **1300** can be attached to a thin pole or tube as well as to a thick bedrail.

[0097] FIG. 13B illustrates an exploded view of the attachment system **1300** according to some embodiments. As is illustrated in FIG. 13B, the cradle **1310** includes a cradle housing **1312** and first lead screw **1314**. The screw **1314** can be positioned inside the cradle housing **1312** and can be allowed to freely rotate inside the housing **1312**. The cradle **1310** also comprises a left closure **1316** and right closure **1318** for attaching the cradle to the device (e.g., NPWT apparatus **230**). The cradle **1310** further includes on the device-facing side a bumper **1320**, which can be made out of rubber. The cradle **1310** also includes a pin **1322**, which can be a coiled spring, screws **1324**, and washers **1326** for attaching the closures **1316** and **1318** to the cradle. The clamp **1330** includes a first clamp arm **1331**, second clamp arm **1332**, a second screw **1335** to which a handle **1334** is attached, and a cap **1336** configured to be attached to the handle **1334**. Pads **1338**, such as a rubber pads, are configured to be attached to the first and second clamp arms **1331** and **1332**. The second clamp arm **1332** includes an opening **1333** for placing the second screw **1335**. The opening **1333** can include interior threading configured to engage with the threading of the second screw **1335**. The second screw **1335** can include a hollow interior tunnel portion for engaging with the first screw **1314**. The interior portion of the second screw **1335** can include threading configured to engage with the threading of the first screw **1314**. In other embodiments, the second screw **1335** is attached to the second clamp arm **1332** using any other suitable attachment.

[0098] In some embodiments, in operation the cradle **1310** is attached to the device (e.g., apparatus **230**). Rear of the device **230** can rest against the bumper **1320** when the cradle **1310** is attached. In some embodiments, recess(es) **1302** and/or closure(s) **1318** can be configured such that the cradle **1310** can be attached to the device only in a configuration in which the rear of the device rests against the bumper **1320**. Attaching the device incorrectly, such as backwards so that the front of the device rests against the bumper **1320**, is not allowed. The attachment system **1300** attaches to a structure, such as pole, rail, or the like, by turning the knob **1334** so that a portion of the structure is placed in between the first and second clamp arms **1331** and **1332**. This is accomplished by action of the first and second screws **1314** and **1335** moving the second clamp arm **1332** to a desired distance from the first clamp arm **1331** (which is stationary). The knob **1334** is then turned to securely mount the device onto the structure. Dismounting is performed by turning to knob **1334** to remove the device from the structure. The cradle can be disconnected from the device by unlatching or unlocking the closure(s) **1318**.

[0099] FIG. 13C illustrates an attachment system **2100** according to some embodiments. The attachment system **2100** can be used to mount to a structure any suitable device,

such as a medical treatment device, including but not limited to NPWT apparatus or device **230**. The attachment system **210** includes a cradle **2110**, first clamp arm **2140**, and second clamp arm **2150**. The first clamp arm **2140** is attached or connected to the cradle **2110**, and thereby remains stationary when the attachment is in operation. The second clamp arm **2150** moves with respect to the first clamp arm **2140**, which varies the gap between the first and second cradle arms. Structure is secured between the first and second cradle arms **2140** and **2150**. The structure can be thin, such as pole **2190'**, or thick, such as pole or rail **2190**.

[0100] The attachment system **2100** includes first and second screws **2160** and **2170**. Second screw **2170** is connected to a knob **2134**. In operation, turning the knob **2170** causes the first and second screws **2160** and **2170** to cause the second clamp arm **2150** to move linearly in smooth and uniform manner with respect to the first clamp arm **2140**. The second clamp arm **2150** moves from a clamped position in which the device is mounted to the structure and an unclamped position in which the device is not mounted to the structure. The second clamp arm **2150** also moves between a fully closed position in which the first and second clamp arms **2140** and **2150** are not separated or substantially not separated (e.g., are in contact with each other) and a fully open position in which the first and second clamp arms **2140** and **2150** are separated by a maximum distance from each other. This maximum distance places an upper limit on the maximum thickness of the structure to which the device can be attached using the attachment system **2100**. Movement of the second clamp arm **2150** is illustrated in views **2100A**, **2100B**, and **2100C**. In view **2100A**, the first and second clamp arms **2140** and **2150** are located close to each other. In views **2100B** and **2100C**, the gap between the first and second clamp arms **2140** and **2150** widens. That is, the second clamp arm **2150** is moved farther away from the first clamp arm **2140**, such as by turning the knob **2134**.

[0101] The first screw **2160** can be located within or substantially within a housing of the cradle, and the first screw **2160** can be allowed to freely rotate inside the housing. The first screw **2160** has a thread with a lead (distance along the screw's axis that is covered by one complete rotation of the screw) and a pitch (distance from the crest of one thread to the next). In one embodiment, the lead and pitch of the first screw are the same. The second screw **2170** has a thread with a lead and a pitch, which may be the same in one embodiment. The threads of the first and second screws **2160** and **2170** can be square, Acme, buttress, and the like. In some embodiments, the first and second screws **2160** and **2170** have threads of the same type, such as Acme threads. In some embodiments, the first and second screws **2160** and **2170** have threads of different type. The second screw **2170** can be connected or attached to the second clamp arm **2150**, such as via an opening **1333** illustrated in FIG. 13B.

[0102] In some embodiments, the thread of the first screw **2160** and the thread of the second screw **2170** can be oriented in opposite directions (or opposite pitch). For example, the thread of the first screw **2160** can be right-handed while the thread of the second screw **2170** can be left-handed and vice versa. When first and second screws **2160** and **2170** with threads oriented in opposite directions are engaged with one another, a single rotation of the handle **2134** provides double or substantially double linear movement as opposed to using a single screw. The first and second screws **2160** and **2170** can be engaged by the second screw **2170** having a hollow open-

ing configured to receive at least a portion of the first screw **2160**. As is illustrated in FIG. **13B**, the hollow opening can have interior thread configured to be engaged with the thread of the first screw **2160**. In some embodiments, the first screw **2160** can include a hollow opening configured to receive at least a part of the second screw **2170**. In other embodiments, first and second screws **2160** and **2170** are engaged in any suitable way, such as via using a nut.

[0103] In some embodiments, such dual-screw arrangement allows for quick mounting to structures of various thickness and while maintaining good control over the tightness (or security) of the attachment to the structure. For example, between about 4 and 10 rotations of the handle are needed to change the configuration of first and second clamp arms **2140** and **2150** from fully closed position to fully open position and vice versa. In some embodiments, a nominal clamping force of the attachment to the structure is approximately 20-30 pound force (lbf) is achieved. The maximum clamping force before part failure can be approximately 100 lbf. Torque required to achieve nominal clamping can be less than about 20 inch pound force (inlb). In other embodiments, other suitable clamping forces, maximum clamping forces, and nominal clamping torques can be used. The dual-screw arrangement can be more durable and cheaper than alternative arrangements, such as using a single screw with steep pitch thread, using a single screw with multi-start threads, and the like.

[0104] In some embodiments, the first and second screws **2160** and **2170** are power screws configured to transform rotary motion into linear motion. Power screws are described in a document titled "Power Screws," which is accessible at http://www.roymech.co.uk/Useful_Tables/Cams_Springs/Power_Screws.html. Efficiency of power screws is described in a document titled "Power Screw Equations," which is accessible at http://www.roymech.co.uk/Useful_Tables/Cams_Springs/Power_Screws_1.html. Power screw strength analysis is provided in a document titled "Strength Considerations for Power Screws," which is accessible at http://www.roymech.co.uk/Useful_Tables/Cams_Springs/Power_Screws_2.html. Each of these documents is incorporated by reference in their entirety.

[0105] In some embodiments, the cradle **2110**, first and second clamp arms **2140** and **2150**, and knob **2134** are made out of plastic material, thereby making the attachment system **2100** lightweight. In some embodiments, one or more of other attachment parts described herein is also made of plastic material. In some embodiments, the first clamp arm is not configured to be stationary while the second clam arm is configured to be stationary. In some embodiments, the first and second clamp arms are non-stationary. In some embodiments, handle is not used.

[0106] FIGS. **13D-13J** illustrate an attachment system according to some embodiments. The attachment system **2200** can be used to mount to a structure any suitable device, such as a medical treatment device, including but not limited to NPWT apparatus or device. FIG. **13D** illustrates a perspective view of the attachment system in a closed or almost closed position. FIG. **13E** illustrates a front view of the attachment system illustrated in FIG. **13D**. FIG. **13F** illustrates a rear view of the attachment system illustrated in FIG. **13D**. FIG. **13G** illustrates a right side view of the attachment system illustrated in FIG. **13D**. FIG. **13H** illustrates a left side view of the attachment system illustrated in FIG. **13D**. FIG. **13I** illustrates a top view of the attachment system illustrated

in FIG. **13D**. FIG. **13J** illustrates a bottom view of the attachment system illustrated in FIG. **13D**. As is illustrated, the attachment system **2200** includes one or more protrusions or projections **2210** which can be used for securing one or more items, such as carry straps, carrying cases or bags, etc.

[0107] FIG. **13K** illustrates attachment systems in operation according to some embodiments. As is illustrated in **2300A**, an apparatus (e.g., NPWT apparatus **230**) is mounted to an IV pole using an attachment system according to some embodiments. As is illustrated in **2300B**, the apparatus is mounted to a bed rail using an attachment system according to some embodiments. Attachment systems illustrated in FIG. **13K** may be selected from any one of attachment systems **1300**, **2100**, or **2200**.

Electronics and Software

[0108] FIG. **14** illustrates an electrical component schematic **1400** of a pump assembly according to some embodiments. Electrical components can operate to accept user input, provide output to the user, operate the pump assembly and the TNP system, provide network connectivity, and so on. Electrical components can be mounted on one or more PCBs, such as the control PCB **260**, peripherals PCB **262**, and/or power supply PCB **264**. As is illustrated, the pump assembly **230** can include multiple processors. It may be advantageous to utilize multiple processors in order to allocate or assign various tasks to different processors. In some embodiments, a first processor can be responsible for user activity and a second processor can be responsible for controlling the pump. This way, the activity of controlling the pump, which may necessitate a higher level of responsiveness (corresponding to higher risk level), can be offloaded to a dedicated processor and, thereby, will not be interrupted by user interface tasks, which may take longer to complete because of interactions with the user.

[0109] The pump assembly **230** can comprise a user interface processor or controller **1410** configured to operate one or more components for accepting user input and providing output to the user, such as the display **206**, buttons **212**, etc. Input to the pump assembly **230** and output from the pump assembly can be controlled by an input/output (I/O) module **1420**. For example, the I/O module can receive data from one or more ports, such as serial, parallel, hybrid ports, and the like. The processor **1410** also receives data from and provides data to one or more expansion modules **1460**, such as one or more USB ports, SD ports, Compact Disc (CD) drives, DVD drives, FireWire ports, Thunderbolt ports, PCI Express ports, and the like. The processor **1410**, along with other controllers or processors, stores data in one or more memory modules **1450**, which can be internal and/or external to the processor **1410**. Any suitable type of memory can be used, including volatile and/or non-volatile memory, such as RAM, ROM, magnetic memory, solid-state memory, Magnetoresistive random-access memory (MRAM), and the like.

[0110] In some embodiments, the processor **1410** can be a general purpose controller, such as a low-power processor. In other embodiments, the processor **1410** can be an application specific processor. In some embodiments, the processor **1410** can be configured as a "central" processor in the electronic architecture of the pump assembly **230**, and the processor **1410** can coordinate the activity of other processors, such as a pump control processor **1470**, communications processor **1430**, and one or more additional processors **1480**. The pro-

processor **1410** can run a suitable operating system, such as a Linux, Windows CE, VxWorks, etc.

[0111] The pump control processor **1470** can be configured to control the operation of a negative pressure pump **1490**. The pump **1490** can be a suitable pump, such as a diaphragm pump, peristaltic pump, rotary pump, rotary vane pump, scroll pump, screw pump, liquid ring pump, diaphragm pump operated by a piezoelectric transducer, voice coil pump, and the like. In some embodiments, the pump control processor **1470** can measure pressure in a fluid flow path, using data received from one or more pressure sensors, calculate the rate of fluid flow, and control the pump. In some embodiments, the pump control processor **1470** controls the pump motor so that a desired level of negative pressure is achieved in the wound cavity **110**. The desired level of negative pressure can be pressure set or selected by the user. In various embodiments, the pump control processor **1470** controls the pump (e.g., pump motor) using pulse-width modulation (PWM). A control signal for driving the pump can be a 0-100% duty cycle PWM signal. The pump control processor **1470** can perform flow rate calculations and detect alarms. The pump control processor **1470** can communicate information to the processor **1410**. The pump control processor **1470** can include internal memory and/or can utilize memory **1450**. The pump control processor **1470** can be a low-power processor.

[0112] A communications processor **1430** can be configured to provide wired and/or wireless connectivity. The com-

ing of logs, alarms, and other operational data, and adjustment of therapy settings, upgrading of software and/or firmware, and the like. In some embodiments, the communications processor **1430** can provide dual GPS/cellular functionality. Cellular functionality can, for example, be 3G functionality. In such cases, if the GPS module is not be able to establish satellite connection due to various factors including atmospheric conditions, building or terrain interference, satellite geometry, and so on, the device location can be determined using the 3G network connection, such as by using cell identification, triangulation, forward link timing, and the like. In some embodiments, the pump assembly **230** can include a SIM card, and SIM-based positional information can be obtained.

[0113] The communications processor **1430** can communicate information to the processor **1410**. The communications processor **1430** can include internal memory and/or can utilize memory **1450**. The communications processor **1430** can be a low-power processor.

[0114] In some embodiments, the pump assembly **230** can store data illustrated in Table 1. This data can be stored, for example, in memory **1450**. In various embodiments, different or additional data can be stored by the pump assembly **230**. In some embodiments, location information can be acquired by GPS or any other suitable method, such as cellular triangulation, cell identification forward link timing, and the like.

TABLE 1

Example Data Stored by the Pump Assembly			
Category	Item	Type	Source
GPS	Location	Latitude, Longitude, Altitude	Acquired from GPS
	Timestamp Location Acquired	Timestamp	
Therapy	Total time therapy ON since device activation	Minutes	Calculated on device
	Total time therapy ON since last maintenance reset	Minutes	based on user control
	Device Placement; accumulated daily hours starting from first Therapy ON after last maintenance reset, stopping at last Therapy OFF before returning for Maintenance and maintenance reset. (Includes both THERAPY ON and THERAPY OFF hours)	Minutes	
Device	Serial Number	Alphanumeric	Set by Pump Utility
	Controller Firmware Version	Alphanumeric	Unique version identifier, hard coded in firmware
Events	Device Event Log (See Table 3 for example)	List of Events (See Table 2)	Generated in response to various user actions and detected events

munications processor **1430** can utilize one or more antennas **1440** (such as antenna **276**) for sending and receiving data. In some embodiments, the communications processor **1430** can provide one or more of the following types of connections: Global Positioning System (GPS) technology, cellular connectivity (e.g., 2G, 3G, LTE, 4G), WiFi connectivity, Internet connectivity, and the like. Connectivity can be used for various activities, such as pump assembly location tracking, asset tracking, compliance monitoring, remote selection, upload-

[0115] In certain embodiments, the pump assembly **230** can track and log therapy and other operational data. Such data can be stored, for example, in the memory **1450**. In some embodiments, the pump assembly **230** can store log data illustrated in Table 2. Table 3 illustrates an example event log according to some embodiments. One or more such event logs can be stored by the pump assembly **230**. As is illustrated, the event log can include timestamps indicating the time of occurrence. In some embodiments, additional and/or alternative data can be logged.

TABLE 2

Example Data Tracked by the Pump Assembly				
Category	ID	Type	Data Content	Notes
Device	0	Startup (Created DB)		First time, out-of-the-box.
	1	Startup (Resumed DB)		Subsequent power-ups.
	2	Startup (Corrupt DB, Recreated)		Corrupt configuration was detected. The database was deleted and recreated, and next run was in out-of-the-box mode.
	3	Shutdown (Signaled)		Normal shutdown, handled/registered by software.
	4	Shutdown (Inferred)		Unexpected shutdown; on next power-up, last active time registered as shutdown event.
Therapy	5	Start Delivery (Continuous)	modes, setpoints	Modes are Y-connect status, and intensity.
	6	Start Delivery (Intermittent)	modes, setpoints	Modes are Y-connect status, and intensity.
	7	Stop Delivery		
	8	Set Therapy Pressure Setpoint	mmHg	This and other therapy adjustment events are only recorded while therapy is being delivered.
	9	Set Standby Pressure Setpoint	mmHg	
	10	Set Intermittent Therapy Duration	setting (30 s, 60 s, etc)	
	11	Set Intermittent Standby Duration	setting (30 s, 60 s, etc)	
	12	SetMode	cont/intermittent	
	13	Set Intensity	low/med/high	
	14	Set Y Connect	yes/no	
Alarm	15	Over Vacuum	high mmHg	
	16	High Vacuum	high deviation mmHg	
	17	Blocked Full Canister	low airflow lpm	
	18	High Flow Leak	high airflow lpm	
	19	Low Vacuum	low mmHg	
	20	Battery Failure		
	21	Critical Battery		
	22	Low Battery		
	23	Inactivity		
Maintenance	24	Maintenance Reset		
	25	Reset to Defaults		
	26	Software/Device Warning	Warning code	Any detected, minor unexpected software behavior will be logged as an event
	27	Software/Device Fault	Fault code	Any detected, severe unexpected software behavior will be logged as an event

TABLE 3

Example Event Log			
Timestamp	Type ID	Type Description	Data
1:23:45 4/2/2012 (UTC-12)	0	Startup (Created DB)	
1:29:23 4/2/2012 (UTC-12)	15	Set Intensity	medium
1:29:43 4/2/2012 (UTC-12)	10	Set Therapy Pressure Setpoint	120 mmHg
1:31:02 4/2/2012 (UTC-12)	7	Start Delivery (Continuous)	120 mmHg continuous, medium intensity, no Y connect
1:44:20 4/2/2012 (UTC-12)	20	High Flow Leak	4 lpm
1:44:24 4/2/2012 (UTC-12)	9	Stop Delivery	

[0116] In some embodiments, using the connectivity provided by the communications processor 1430, the device can upload any of the data stored, maintained, and/or tracked by the pump assembly 230. In some embodiments, the following information can be uploaded to a remote computer or server: activity log(s), which includes therapy delivery information, such as therapy duration, alarm log(s), which includes alarm type and time of occurrence; error log, which includes internal error information, transmission errors, and the like; therapy duration information, which can be computed hourly, daily, and the like; total therapy time, which includes therapy

duration from first applying a particular therapy program or programs; lifetime therapy information; device information, such as the serial number, software version, battery level, etc.; device location information; patient information; and so on. The device can also download various operational data, such as therapy selection and parameters, firmware and software patches and upgrades, and the like. In certain embodiments, the device can provide Internet browsing functionality using one or more browser programs, mail programs, application software (e.g., apps), etc. In various embodiments, additional processors 1480, such as processor for controlling the display 206, can be utilized.

[0117] FIG. 15 illustrates a firmware and/or software diagram 1500 according to some embodiments. A pump assembly 1520 includes a user interface processor firmware and/or software 1522, which can be executed by the user interface processor 1410, pump control processor firmware and/or software, which can be executed by the pump control processor 1470, communications processor firmware and/or software 1526, which can be executed by the communications processor 1430, and additional processor(s) firmware and/or software, which can be executed by one or more additional processors 1480. The pump assembly 1520 can be connected to a computer 1510, which can be a laptop, desktop, tablet, smartphone, and the like. A wired or wireless connection can be utilized to connect the computer 1510 to the pump assembly 1520. In some embodiments, a USB connection is used. The connection between the computer 1510 and the pump

assembly **1520** can be used for various activities, such as pump assembly location tracking, asset tracking, compliance monitoring, selection, uploading of logs, alarms, and other operational data, and adjustment of therapy settings, upgrading of software and/or firmware, and the like. The pump assembly **1520** and computer **1510** can communicate with a remote computer or server **1540** via the cloud **1530**. The remote computer **1540** can include a data storage module **1542** and a web interface **1544** for accessing the remote computer.

[**0118**] The connection between the computer **1510** and pump assembly **1520** can be utilized to perform one or more of the following: initialization and programming of the pump assembly **1520**, firmware and/or software upgrades, maintenance and troubleshooting, selecting and adjusting therapy parameters, and the like. In some embodiments, the computer **1510** can execute an application program for communicating the pump assembly **1520**.

[**0119**] The pump assembly **1520** can upload various data to the remote computer **1540** via the cloud **1530**. In some embodiments, the pump assembly **1520** can upload data to one or more remote computers **1540**. As explained above, upload data can include activity log(s), alarm log(s), therapy duration information, total therapy time, lifetime therapy information, device information, device location information, patient information, etc. In addition, the pump assembly **1520** can receive and process commands received from the cloud **1530**.

Remote Interface

[**0120**] FIGS. **16A-16S** illustrate remote interface screens or pages according to some embodiments. These screens can be generated in the web interface **1544** of the remote computer **1540**. The remote computer **1540** can be referred to as a cloud platform. FIG. **16A** illustrates a login screen **1600A** for accessing data uploaded by one or more devices. The login screen **1600A** includes a menu **1610**, comprising menu item **1612** for accessing a home page, menu item **1614** for accessing device records, menu item **1616** for accessing fleet status, and menu item **1618** for accessing contacts page. The login screen **1600A** also includes a search box **1632** for locating device information, a logout button **1634**, and additional information menu **1636** for displaying accessibility information, terms of use, patent, trademark, and copyright notices, and disclaimers. Menu items **1612** through **1618** and the search box **1632** can be deactivated until the cloud platform **1540** successfully verifies user's credentials.

[**0121**] The login screen **1600A** comprises a login window **1602** where a user enters credential for verification. If the user has forgotten their password, a link can be sent to the user's email account to allow the user to reset the password. After the cloud platform **1540** has verified the submitted login credentials, the application will display a home page **1600B** illustrated in FIG. **16B**. The home page **1600B** displays an image of the device, a welcome message, the menu **1610**, in which menu items have been activated, search box **1632** which has been activated, and logout button **1634**. From the home screen **1600B**, the user can select the device records **1614** menu item or fleet status menu item **1616** depending on whether the user would like to view one or multiple devices.

In some embodiments, various groups of users with various privileges can be supported. For example, a treatment facility user group for facilities that own or rent multiple devices, can have administrator privileges allowing one or more users to add and/or remove devices. To accomplish this, the menu **1610** can have additional and/or alternative menu items, such as administrator item.

[**0122**] The user can select device records menu item **1614**, which can bring up a device records screen **1600C** illustrated in FIG. **16C**. The device records screen **1600C** includes a menu **1620** comprising menu items for searching devices **1621**, device summary information **1622**, device therapy information **1623**, device alarms information **1624**, device software and/or firmware updates **1625**, device error log information **1626**, and device location tracking **1627**. The device records screen **1600C** provide a list or table **1604** of all devices available to the user. The results can be split into separate pages to reduce page upload time. The table **1604** can be filtered by the search menu and can be sorted in ascending or descending order. The user can also select how many entries will be displayed per page.

[**0123**] Upon selecting a device in the table **1604**, a device summary screen **1600D** illustrated in FIG. **16D**. In some embodiments, the user's login privileges will determine which data items will be shown on the page and whether the current device location will be reported. Table 4 illustrates which data items are visible on the device summary screen **1600D**, according to the user's user group according to certain embodiments. As is illustrated in the table, the following user groups can be supported: administrator, clinician, billing, distributor/purchaser logistics, distributor/purchaser customer service/technical support, maintenance, customer service, hotline, logistics. In Table 4, FIG. **2-5** corresponds to FIG. **16D**, FIG. **2-6** corresponds to FIG. **16E**, FIG. **2-7** corresponds to FIG. **16F**, FIG. **2-8** corresponds to FIG. **16G**, FIG. **2-9** corresponds to FIG. **16H**, FIG. **2-10** corresponds to FIG. **16I**, and FIG. **2-11** corresponds to FIG. **16J**.

[**0124**] Device properties can be shown in table **1605** and location information, including a map **1606a**, can be shown in table **1606**. All values shown in tables **1605** and **1606** can reflect the latest dataset uploaded from the device. In some embodiments, where appropriate, a tooltip feature can be added to tables **1605** and **1606** to provide more detail (e.g., the definition of "Device Placement") when a user hovers a pointing device over a particular table item. As is illustrated in table **1606**, map **1606a** is used to display the latest reported address. The location coordinates, the time that this location was acquired by GPS (or via cellular network data), and the nearest street address are displayed alongside the map. The closest street address can be determined via reverse geocoding.

[**0125**] According to some embodiments, the device summary screen **1600D** corresponds to a summary screen as viewed by a user having administrator ("Admin") privileges. As shown in Table 4, members of the "Admin" User Group will have access to all data items and navigation choices. All other User Groups will have access to various subsets of this screen, as described in Table 4. For example, FIG. **16E** displays the summary screen **1600E** as viewed by a user that has been assigned to a "Clinician" user group. Such user can view information listed in table **1607**.

TABLE 4

Example Access to Device Information Based on Use Credentials									
		User Interface Accessibility							
		Summary Screen (FIGS. 2-5, 2-6)							
User Group	Members	Edit Device Properties	Serial Number	Total Patient Therapy	Device Placement	Manufacture Date	Software Version	Battery Charge	Battery Life
Admin	Website Administrator (S&N)	Y	Y	Y	Y	Y	Y	Y	Y
Clinician	Clinician		Y	Y					
Billing	Customer—Renter (Billing)		Y	Y	Y				
	Distributor/Purchaser (Billing)								
	Billing (S&N)								
D/P Logistics	Distributor/Purchaser (Logistics)		Y						
D/P CSTS	Distributor/Purchaser (Cust Serv/ Tech Support)		Y	Y		Y	Y	Y	
Maintenance	Distributor/Purchaser (Maintenance)		Y	Y		Y	Y	Y	Y
	Quality & Complaints (S&N)								
	Service & Repair (S&N)								
Customer Svc	Customer Service (S&N)		Y						
Hotline	Clinical/Technical Hotline (S&N)		Y	Y		Y	Y	Y	
Logistics	Logistics (S&N)		Y			Y	Y		Y

		User Interface Accessibility						
		Summary Screen (FIGS. 2-5, 2-6)		Therapy Log	Alarms Log	Software Update Log	Error Log	Location Tracking
User Group	Members	Device Lifetime Therapy	Location	Screen (FIG. 2-7)	Screen (FIG. 2-8)	Screen (FIG. 2-9)	Screen (FIG. 2-10)	Screen (FIG. 2-11)
Admin	Website Administrator (S&N)	Y	Y	Y	Y	Y	Y	Y
Clinician	Clinician			Y	Y			
Billing	Customer—Renter (Billing)			Y				
	Distributor/Purchaser (Billing)							
	Billing (S&N)							
D/P Logistics	Distributor/Purchaser (Logistics)		Y					Y
D/P CSTS	Distributor/Purchaser (Cust Serv/ Tech Support)			Y	Y			
Maintenance	Distributor/Purchaser (Maintenance)	Y	Y	Y	Y	Y	Y	
	Quality & Complaints (S&N)							
	Service & Repair (S&N)							
Customer Svc	Customer Service (S&N)		Y					Y
Hotline	Clinical/Technical Hotline (S&N)			Y	Y			
Logistics	Logistics (S&N)	Y	Y			Y		Y

[0126] FIG. 16F illustrates device therapy information screen 1600F. The screen 1600F can be selected via menu item 1623. In some embodiments, events listed in the therapy log 1652 include all therapy ON and OFF events, as well as adjustments to therapy mode and pressure. All past uploaded data can be displayed with each event sorted by its timestamp or in any order selected by the user. Device properties editor 1642 and report generator 1644 can be selected by the user to perform functions explained below.

[0127] FIG. 16G illustrates device alarm information screen 1600G. The screen 1600G can be selected via menu item 1624. In some embodiments, alarm logs listed in the table 1654 provide a sequential listing of each alarm event. Each event is described by the alarm type and any relevant data (e.g. over-vacuum high pressure). Different ordering options can be selected by the user. FIG. 16H illustrates device software information screen 1600H. The screen 1600H can be selected via menu item 1625. In some embodiments, the table 1656 lists all past successful (and, optionally, unsuccessful) software updates by their timestamps or in any other order selected by the user.

[0128] FIG. 16I illustrates device error information screen 1600I. The screen 1600I can be selected via menu item 1626. In some embodiments, the table 1658 lists each logged error event sequentially in the order selected by the user. The error fault or warning code is provided for each error event. FIG. 16J illustrates device location information screen 1600J. The screen 1600J can be selected via menu item 1627. In some embodiments, the table 1660 lists all past reported locations of the device. A map 1600a illustrates markers at up to N of the most recent reported locations. N can be any suitable integer number. If a row 1660b in the table 1600 is selected, then the corresponding marker on the map 1600a will be highlighted.

[0129] FIG. 16K illustrates device properties editor screen 1600K. The screen 1600K can be selected via button 1642. In some embodiments, device properties editor 1662 allows the user to update device data not uploaded by the device, such as, for example, manufacturing date 1664, distributor information 1666, and facility information 1668. The distributor 1666 and facility 1668 fields can be drop down menus that show all distributor device groups stored on the cloud system 1540 and

all facilities device groups stored under the selected distributor. Updated information can be saved in the cloud system **1540**, such as in the data storage module **1542**, by pressing the update button **1669**.

[0130] FIG. **16L** illustrates report generator screen **1600L**. The screen **1600L** can be selected via button **1644**. In some embodiments, report generator **1670** can be used to download reports of past and current device records in CVS, PDF, or any other suitable format. The format of the report can be selected in **1672**, report dates can be selected in **1676**, properties for including in the report can be selected in **1676**, and report can be generated and downloaded by pressing button **1678**.

[0131] In some embodiments, a user, such as a facility user, can view multiple devices owned and/or leased. These devices can be referred to as a fleet. Fleet management can be selected via menu item **1616**, which brings up a set of menus that displays the latest data from multiple devices in the user's current fleet.

[0132] In certain embodiments, to access fleet records, the user should first select one or more devices from the fleet search screen **1600M** illustrated in FIG. **16M**. Screen **1600M** can be selected via menu items **1616** and **1621**. Screen **1600M** includes search menu **1682** and results table **1684**. Data associated with one or more devices from the fleet can be displayed by pressing button **1686**. Fleet device properties screen **1600N** illustrated in FIG. **16N** shows a list of summary data for a set of devices selected in the fleet search screen **1600M**. Device properties are listed in the table **1690**. The properties screen **1600N** can be accessed via menu item **1622**. Therapy data for the selected devices can be viewed by selecting menu item **1623** to bring up fleet device therapy information screen **1600O** illustrated in FIG. **16O**. In some embodiments, latest therapy information for all selected devices can be viewed in table **1692**.

[0133] In various embodiments, fleet device battery information screen **1600P** illustrated in FIG. **16P** shows the last reported battery life and battery charge for all selected devices. Battery information can be displayed in the table **1694**. The fleet battery information screen **1600P** can be selected via menu item **1628**. Fleet device software information screen **1600Q** illustrated in FIG. **16Q** shows the current software version, in table **1685**, for all selected devices. The fleet device software information screen **1600Q** can be selected via menu item **1629**. Fleet device location information screen **1600R** illustrated in FIG. **16R** shows the last reported address for all selected devices. The fleet location information screen **1600Q** can be selected via menu item **1629**. Device location information can be shown in table **1696** which includes a map **1696a**. In some embodiments, the map **1696a** includes markers for N past locations of each selected device, where N is a suitable integer number.

[0134] Contacts page **1600S** illustrated in FIG. **16S** can be selected via menu item **16518**. Contact information, such as administrative and technical contacts information, can be provided in window **1698**.

Graphical User Interface

[0135] FIGS. **17A-17V** illustrate graphical user interface (GUI) screens according to some embodiments. The GUI screens can be displayed on the screen **206**, which can be configured as a touchscreen interface. Information displayed on the screens can be generated by and input received from the user can be processed by the processor **1410**. The GUI screens can be utilized for initializing the device, selecting

and adjusting therapy settings, monitoring device operation, uploading data to the cloud, and the like. Even though some of the screens **1700A-1700D** include an outer Adobe Flash Player **10** window, the screens **1700A-1700D** can be executed without Flash Player. In some embodiments, the screens **1700A-1700D** can be generated directly by an operating system running on the processor **1410** and/or by a graphical user interface layer running on top of the operating system. For instance, the screens can be developed using Qt framework available from Digia.

[0136] FIGS. **17A-17D** illustrated GUI screens **1700A-1700D** for initializing the device according to various embodiments. In some embodiments, screens **1700A-1700D** can be displayed when the device is powered on for the first time, after device reset, etc. Screen **1700A** of FIG. **17A** allows the user to select language in which the device will display and/or announce information to the user. The scroll bar **1702** allows the user to scroll through available languages. The user can select a desired language by pressing or tapping menu item **1701**. After selecting the language, screen **1700B** of FIG. **17B** can be displayed to allow the user to select the time zone. The user can select the desired time zone by pressing menu item **1704**. The user can return to the previous screen by pressing arrow **1703**. In screen **1700C** of FIG. **17C**, the user can confirm the time zone selection by accepting it via button **1705** or rejecting it via button **1706**. In screen **1700D** of FIG. **17D**, the user can complete the initialization by pressing the button **1707**.

[0137] FIG. **17E** illustrates a home screen **1700E** according to some embodiments. The home screen **1700E** can be displayed after the user has initialized the device. The home screen **1700E** includes a status bar **1712** that comprises icons indicating operational parameters of the device. Animated icon **1713** is a therapy delivery indicator. In some embodiments, when therapy is not being delivered, icon **1713** is static and gray. When therapy is being delivered, icon **1713** turns orange and rotates (e.g., clockwise). Other status bar icons include volume indicator, and GPS and 3G connection indicator. The home screen includes a battery indicator **1716** for indicating battery charge level and date/time information **1718**. The home screen **1700E** includes a menu **1720** comprising menu items **1722** for accessing device settings, **1724** for accessing logs, **1726** for accessing help, and **1728** (see FIG. **17G**) for returning to the home screen from other screens. In some embodiments, the device can be configured so that after a period of inactivity, such as not receiving input from the user, home screen **1700E** is displayed.

[0138] The home screen **1700E** includes therapy settings **1730** comprising negative pressure up and down controls **1732** and **1734** and scroll bar **1736** for adjusting the level of negative pressure. In some embodiments, up and down controls **1732** and **1734** adjust reduced pressure by a suitable step size, such as ± 5 mmHg. As is indicated by label **1738**, the current therapy selection is -80 mmHg. The home screen **1700E** includes continuous/intermittent therapy selection **1740**. Continuous therapy selection screen can be accessed via control **1742** and intermittent therapy selection screen can be accessed via control **1744**. In certain embodiments, home screen **1700E** illustrates continuous therapy selection screen. The home screen **1700E** includes Y-connector selection **1745** for treating multiple wounds. Control **1746** selects treatment of a single wound, and control **1748** selects treatment of more than one wound by the device.

[0139] FIG. 17F illustrates home screen 1700F for selecting intermittent therapy according to some embodiments. Screen 1700F can be accessed via control 1744. Home screen 1700F includes intermittent therapy settings 1750 and 1755. As is illustrated by controls 1752, 1754, 1756, and 1758, current therapy selection is applying -80 mmHg for 5 minutes followed by 2 minutes of applying atmospheric pressure (or turning off the vacuum pump). Negative pressure levels and durations can be adjusted by selecting one of controls 1752, 1754, 1756, or 1758 and operating the up and down controls 1732 and 1736 or scroll bar 1736.

[0140] FIG. 17G illustrates settings screen 1700G according to some embodiments. Screen 1700G can be selected via menu item 1722. As is illustrated, wound volume 1760 can be adjusted (currently low wound volume corresponding to a small wound is selected), therapy intensity 1764 can be adjusted (currently low intensity is selected), and wound wizard 1768 can be activated (current selection is low/small). FIG. 17H illustrates wound volume selection screen 1700H, in which low volume (small wound) 1761, medium volume (medium wound) 1762, or high volume (large wound) 1763 can be selected. FIG. 17I illustrates therapy intensity selection screen 1700I, in which low intensity 1765, medium intensity 1766, or high intensity 1767 can be selected. In some embodiments, therapy intensity can be correspond to the volume of wound exudate and default negative pressure levels can be associated with various levels of therapy intensity. FIG. 17J illustrates wound wizard screen 1700J, in which small, low exudating wound 1769 can be selected, medium, moderately exudating wound 1770 can be selected, or large, high exudating wound 1771 can be selected. Therapy settings can be adjusted in accordance with user's selection of a wound type.

[0141] FIG. 17K illustrates a flow meter gauge screen 1700K according to some embodiments. The screen 1700K graphically indicates current leak rate in the system. The screen 1700K includes a dial 1775 with markings 1777, 1778, and 1779 and a gauge 1776. Low leak levels are illustrated by position of the gauge 1776. Higher leak rates may trigger an alarm.

[0142] FIG. 17L illustrates log screen 1700L for accessing therapy log data, alarm log data, and the like. The log screen 1700L can be selected via menu item 1724. The log screen 1700L includes therapy counter 1783 (e.g., relative to last device reset), log view selection controls 1781 and 1782, and log data viewer 1784. Control 1781 selects detailed view, and control 1782 selects overview presentation of log data. In some embodiments, screen 1700L illustrates detailed view of log data. Log data viewer 1784 illustrates events separated by calendar days 1785 and 1787. Calendar day 1785 shows that on Jan. 1, 2012, -120 mmHg of negative pressure therapy is being delivered starting at 12:30 am. Calendar day 1787 shows that on Dec. 31, 2012, the device experienced a blockage/canister full alarm at 7:33 pm (1788), at 7:45 pm intermittent therapy between -80 mmHg and atmospheric pressure (0 mmHg) was delivered (1789), and that delivery of the therapy was stopped at 11:45 pm (1790).

[0143] FIG. 17K illustrates log data overview screen 1700M according to some embodiments. The screen 1700M can be selected via control 1782. The overview screen 1700M includes a graph 1792 displaying log data corresponding to calendar days. Desired month can be selected using controls 1793. Bars, such as 1798, graphically illustrate therapy delivery time corresponding to a calendar day 1794. For example,

on December 21 (1794) 15 hours of therapy (1798) was delivered. In addition, alarm events are indicated by lines on the bars, such as lines 1795 and 1796. In some embodiments, pressing or tapping on a particular bar, such as bar 1798, can bring up a detailed view (not shown) of logged events for the corresponding day.

[0144] FIG. 17N illustrates help screen 1700N according to some embodiments. The main help screen 1700N can be accessed via control 1726. Help screen 1726 includes a menu of help items for alarms/troubleshooting 1802, reference guide 1804, video guides 1806, user guide 1808, and customer assistance 1810. Each of these items can be selected by pressing on a corresponding control. FIG. 17O illustrates video guides screen 1700O, which can be accessed via control 1806. The screen 1700O includes a list of videos, such as instructional videos for operating the device and/or system. Videos, reference guides, user guides, and the like can be stored in the device memory (e.g., memory 1450), downloaded and/or streamed from a network using a wired or wireless connection. In some embodiments, a list of available videos, reference guides, user guides, etc. is downloaded from a remote server and, in response to the user selecting a particular video or guide for viewing, the selected material is downloaded from the network and/or streamed over the network. A desired video can be selected and viewed, as shown in screen 1700P of FIG. 17P. The selected video can be viewed, paused, stopped, etc. by operating control 1814. FIG. 17Q illustrates a user guide screen 1700Q, which can be accessed via control 1808. User can scroll through information displayed in the screen 1700Q.

[0145] FIG. 17R illustrates alarm screens 1700R according to some embodiments. For example, during therapy delivery the device can detect high vacuum condition (e.g., high levels of vacuum are being applied to the wound cavity 110). The device can display a high vacuum alarm as is shown in the left screen of FIG. 17R indicting that high vacuum was detected while delivering therapy (information bar 1822). Because in certain embodiments such alarm cannot be silenced, therapy is paused, as is indicated by information bar 1822 shown on the right screen in FIG. 17R. This screen is displayed after the user presses therapy pause button 212b as prompted by the screen on the left side of FIG. 17R. User can troubleshoot the system by selecting control 1820. If troubleshooting is successfully perform (e.g., leak is mitigated or eliminated), the device can display screen 1700T of FIG. 17T, and user can restart delivery of therapy.

[0146] FIG. 17S illustrates alarm screens 1700S according to certain embodiments. A low battery alarm is illustrated. In some embodiments, this alarm can be silenced for a period of time, during which delivery of therapy is being continued. The user can silence the alarm by selecting control 1823. Message 1824 can then be displayed alerting the user to charge the battery.

[0147] FIGS. 17U-17V illustrate data upload screens according to some embodiments. As is shown in screens 1700U, user can access data upload window 1830, which includes data upload controls 1832 (for starting the upload) and 1834 (for cancelling). If the user selects control 1832, message 1835 is displayed to the user indicating the data is being sent to the remote computer. If upload is successful, a confirmation screen (not shown) can be displayed. Such confirmation screen can automatically fade away after a period of time. However, if the upload is not successful, screen 1700V of FIG. 17V can be displayed. The user can retry the

upload by selecting control **1838** or access upload troubleshooting information by selecting control **1836**.

[0148] FIG. **18** illustrates a process **1850** of operating a device according to some embodiments. The process **1850** can be executed by the processor **1410**. In block **1852**, the process **1850** provides GUI screens to the user. In block **1854**, the process **1850** receives input from the user. In block **1856**, the process **1856** performs one or more operations in accordance with input received from the user.

Flow Rate Monitoring

[0149] Some embodiments of the system monitor and/or determine a rate of flow of fluid in the system. In certain embodiments, flow rate monitoring can be performed by the pump control processor **1470** alone or in combination with the processor **1410**. Monitoring the flow rate can be used, among other things, to ensure that therapy is properly delivered to the wound, to detect blockages, canister full conditions, and/or leaks in the fluid flow path, high pressure, ensure that the flow rate is not unsafe (e.g., dangerously high), etc.

[0150] In some embodiments, the system performs flow rate monitoring by measuring and/or monitoring speed of vacuum pump motor, such as, by using a tachometer. The pump control processor **1470** can continuously monitor voltage and/or current at which the pump is being driven using the tachometer feedback from the pump. Tachometer feedback can be used to determine the pump speed. If pump speed falls below a threshold value over a particular period of time, such as 2 minutes, it can be determined that a blockage is present in the flow path. The blockage can be due to a blockage in a tube or lumen, canister being full, etc. An alarm can be triggered and the system can wait for the user to take one or more actions to resolve the blockage.

[0151] In various embodiments, tachometer can be read periodically, such as every 100 msec, and periodic readings made over a time duration, such as 32 sec, can be combined (e.g., averaged). Combined tachometer readings can be used for leak detection, blockage detection, limiting the maximum flow rate, etc. Combined tachometer readings (e.g., in counts) can be converted to a flow rate (e.g., in mL/min) using one or more conversion equations and/or tables so that a current flow rate is determined. In some embodiments, the flow rate is determined according to the following equation:

$$FR=C_1*F*P+C_2$$

[0152] where FR is the flow rate, F is the frequency of the pump tachometer signal, P is pressure produced by the pump, and C_1 and C_2 are suitable constants. The determined flow rate can be compared to various flow rate thresholds, such as blockage threshold, leakage threshold, and maximum flow rate threshold, to determine a presence of a particular condition, such as a blockage, leakage, over-vacuum.

[0153] In some embodiments, a blockage condition is detected when the determined flow rate falls below a blockage threshold. A blockage alarm can be enabled if the blockage condition is present for a period of time, such as 30 seconds. The blockage alarm can be disabled when the determined flow rate exceeds the blockage threshold. In some embodiments, the system can differentiate between a blockage in a tube or lumen and canister full conditions. In some embodiments, a leakage condition is detected when the determined flow rate exceeds a leakage threshold. A leakage alarm can be enabled if the leakage condition is present for a period of time, such as 30 seconds. The leakage alarm can be disabled when

the detected flow rate exceeds the leakage threshold. In some embodiments, in order to prevent an over-vacuum condition, a maximum flow rate is imposed, such as 1.6 liters/min Pump drive signal, such as voltage or current signal, can be limited not exceed this flow rate threshold.

[0154] In certain embodiments, one or more pressure sensors can be placed in suitable locations in the fluid flow path. Pressure measured by the one or more sensors is provided to the system (e.g., pump control processor **1470**) so that it can determine and adjust the pump drive signal to achieve a desired negative pressure level. The pump drive signal can be generated using PWM. Additional details of flow rate detection and pump control are provided in U.S. patent application Ser. No. 13/589,021, which is assigned to the assignee of the present application is incorporated by reference in its entirety.

[0155] In some embodiments, flow rate monitoring is performed by measuring flow through a flow restrictor placed in a portion of the fluid flow path. In certain embodiments, flow restrictor **278** illustrated in FIG. **2F** can be used. The flow restrictor can be calibrated such that it can be used to reliably monitor flow rate for different types of wounds, dressings, and operating conditions. For example, a high precision silicon flow restrictor can be used. The flow restrictor can be located at any suitable location in the flow path, such as between the source of the negative pressure and the canister, such as upstream of the source of the negative pressure and downstream of the canister. A differential pressure sensor or two pressure sensors can be used to measure a pressure drop across the flow restrictor. For example, as explained above in connection with FIG. **2F**, the pressure drop across the flow restrictor **278** can be measured using sensors **282** and **284**. In certain embodiments, if the pressure drop falls below a pressure differential threshold, which indicates low flow, the measured flow rate is compared to a flow rate threshold. If the measured flow rate falls below the flow rate threshold, blockage condition is detected. Additional details of blockage detection are provided in U.S. Patent Publication No. 2011/0071483, which is assigned to the assignee of the present application is incorporated by reference in its entirety. In some embodiments, the measured flow rate is compared to a leakage threshold. If the measured flow rate exceeds the leakage threshold, a leak is detected. Additional details of leakage detection are provided in U.S. Pat. No. 8,308,714, which is assigned to a subsidiary of the assignee of the present application and is incorporated by reference in its entirety.

[0156] In some embodiments, blockages and presence of fluid in one or more tubes or lumens are detected by processing data from one or more pressure sensors, such as sensors **280**, **282**, and **284**. This detection can be enhanced by changing one or more settings of the vacuum pump, such as increasing vacuum level delivered by the pump, decreasing the vacuum level, stopping the pump, changing the pump speed, changing a cadence of the pump, and the like. In some embodiments, as the pump operates, it generates pressure pulses that are propagated through the fluid flow path. The pressure pulses are illustrated in the pressure curve **1902** of FIG. **19A** according to some embodiments. Region **1904** illustrates pressure pulses detected during normal operation of the system, and region **1906** illustrates pressure pulses detected when canister becomes full. As is illustrated, canister blockage causes a reduced volume to be seen upstream of the canister, and the amplitude of the pressure pulses increases. In certain embodiments, this change or "bounce" in the pressure pulse signal can be magnified or enhanced by

varying the pump speed, varying the cadence of the pump, such as by adjusting PWM parameters, and the like. Such adjustments of pump operation can be performed over a short time duration and the changes can be small such that the operation of the system remains relatively unaffected.

[0157] In some embodiments, the increase in the amplitude of pressure pulses (region **1906**) can be detected and compared to a blockage threshold in order to determine whether a blockage condition exists. In certain embodiments, the frequency, rate of change of the amplitude (or slope), rate of change of the frequency, etc. of the pressure pulse signal can be monitored in place of or in addition to monitoring the amplitude. For example, curve **1910** of FIG. **19B** illustrates pressure sensed by a pressure sensor downstream of the canister filter. As is shown, small or no pressure pulses are detected when the canister filter becomes blocked. A large negative change in the detected pressure signal is observed, as is illustrated by the slope **1912**. In some embodiments, signal processing techniques can be utilized, such as converting the detected pressure pulse signal into frequency domain, for example by using the Fast Fourier Transform (FFT), and analyzing the pressure pulse signal in the frequency domain. Additional details of flow rate detection are described in U.S. Patent Publication No. 2012/0078539, which is assigned to the assignee of the present application is incorporated by reference in its entirety.

[0158] In some embodiments, temporary blockages caused by slugs of fluid in tubes or lumens are detected by turning off the pump and monitoring the pressure change in the fluid flow path. The pump can be turned off for a short duration of time as to not affect the operation of the system. Presence of temporary blockages in the system due to slugs of fluid can cause vacuum level to decline in a discontinuous “stair and risers” pattern, such as that illustrated by curve **2002** of FIG. **20**. This discontinuous decaying pattern is due to slugs of fluid moving through the fluid flow path and arriving at the canister inlet, which can suddenly change the volume seen by the pressure sensor (and the pump). When slugs of fluid are not present, a more continuous decaying pattern, such as illustrated in curve **2004**, is observed. In certain embodiments, when the pattern illustrated in curve **2002** is detected, the system can increase the level of vacuum produced by the pump to clear the slugs.

[0159] In some embodiments, one or more flow sensors and/or flow meters can be used to directly measure the fluid flow. In some embodiments, the system can utilize one or more of the above flow rate monitoring techniques. The system can be configured to suitably arbitrate between flow rates determined using multiple flow rate monitoring techniques if one or more such techniques are executed in parallel. In certain embodiments, the system execute one of the techniques, such as the flow rate determination based on the pump speed, and utilize one or more other techniques as needed. In various embodiments, the system can utilize one or more other techniques in cases the determine flow rate is perceived to be inaccurate or unreliable.

[0160] Other Variations

[0161] Any value of a threshold, limit, duration, etc. provided herein is not intended to be absolute and, thereby, can be approximate. In addition, any threshold, limit, duration, etc. provided herein can be fixed or varied either automatically or by a user. Furthermore, as is used herein relative terminology such as exceeds, greater than, less than, etc. in relation to a reference value is intended to also encompass

being equal to the reference value. For example, exceeding a reference value that is positive can encompass being equal to or greater than the reference value. In addition, as is used herein relative terminology such as exceeds, greater than, less than, etc. in relation to a reference value is intended to also encompass an inverse of the disclosed relationship, such as below, less than, greater than, etc. in relations to the reference value.

[0162] Features, materials, characteristics, or groups described in conjunction with a particular aspect, embodiment, or example are to be understood to be applicable to any other aspect, embodiment or example described herein unless incompatible therewith. All of the features disclosed in this specification (including any accompanying claims, abstract and drawings), and/or all of the steps of any method or process so disclosed, may be combined in any combination, except combinations where at least some of such features and/or steps are mutually exclusive. The protection is not restricted to the details of any foregoing embodiments. The protection extends to any novel one, or any novel combination, of the features disclosed in this specification (including any accompanying claims, abstract and drawings), or to any novel one, or any novel combination, of the steps of any method or process so disclosed.

[0163] While certain embodiments have been described, these embodiments have been presented by way of example only, and are not intended to limit the scope of protection. Indeed, the novel methods and systems described herein may be embodied in a variety of other forms. Furthermore, various omissions, substitutions and changes in the form of the methods and systems described herein may be made. Those skilled in the art will appreciate that in some embodiments, the actual steps taken in the processes illustrated and/or disclosed may differ from those shown in the figures. Depending on the embodiment, certain of the steps described above may be removed, others may be added. For example, the actual steps and/or order of steps taken in the disclosed processes may differ from those shown in the figure. Depending on the embodiment, certain of the steps described above may be removed, others may be added. For instance, the various components illustrated in the figures may be implemented as software and/or firmware on a processor, controller, ASIC, FPGA, and/or dedicated hardware. Any disclosed hardware component or module can include logic circuitry. Furthermore, the features and attributes of the specific embodiments disclosed above may be combined in different ways to form additional embodiments, all of which fall within the scope of the present disclosure.

[0164] User interface screens illustrated and described herein can include additional and/or alternative components. These components can include menus, lists, buttons, text boxes, labels, radio buttons, scroll bars, sliders, checkboxes, combo boxes, status bars, dialog boxes, windows, and the like. User interface screens can include additional and/or alternative information. Components can be arranged, grouped, displayed in any suitable order.

[0165] Although the present disclosure includes certain embodiments, examples and applications, it will be understood by those skilled in the art that the present disclosure extends beyond the specifically disclosed embodiments to other alternative embodiments and/or uses and obvious modifications and equivalents thereof, including embodiments which do not provide all of the features and advantages set forth herein. Accordingly, the scope of the present disclosure

is not intended to be limited by the specific disclosures of preferred embodiments herein, and may be defined by claims as presented herein or as presented in the future.

1.-73. (canceled)

74. A system for applying negative pressure to a wound, the system comprising:

a housing comprising a source of negative pressure and a controller, the source of negative pressure configured to be in fluidic communication with a wound dressing placed over the wound, and the controller configured to operate the source of negative pressure to aspirate fluid from the wound; and

a mounting system configured to attach the housing to a structure, the mounting system comprising:

a cradle configured to be removably attached to the housing;

a first clamp arm attached to the cradle and a second clamp arm, the second clamp arm configured to be moved between a clamped position and an unclamped position, wherein the first and second clamp arms are configured to be substantially securely attached to the structure in the clamped position;

a first screw engaged with a second screw; and the second screw configured to move the second arm between the clamped and unclamped positions.

75. The system according to claim **74**, wherein the first screw comprises a substantially hollow interior portion, and at least a part of the second screw is configured to be positioned in the interior portion of the first screw in the clamped position.

76. The system according to claim **74**, wherein the first screw comprises a first thread oriented in a first direction, and the second screw comprises a second thread oriented in a second direction opposite from the first direction.

77. The system according to claim **74**, further comprising a handle, whereby a rotation of the handle causes the second arm to move a distance proportional to an aggregate of a first lead of the first screw and a second lead of the second screw.

78. An attachment system for mounting an apparatus, the attachment system comprising:

a cradle configured to be removably attached to the apparatus;

a first clamp arm attached to the cradle and a second clamp arm, the second clamp arm configured to be moved between a clamped position and an unclamped position, wherein the first and second clamp arms are configured to be substantially securely attached to a structure in the clamped position;

a first screw engaged with a second screw; and the second screw configured to move the second arm between the clamped and unclamped positions.

79. The attachment system according to claim **78**, wherein the first and second arms are configured to not be substantially securely attached to the structure in the unclamped position.

80. The attachment system according to claim **78**, wherein the second screw is attached to the second arm.

81. The attachment system according to claim **78**, further comprising a knob attached to the second screw, the knob configured to move the second arm between the clamped and unclamped positions.

82. The attachment system according to claim **78**, wherein the first and second screws are power screws.

83. The attachment system according to claim **78**, wherein the first screw comprises a first thread and the second screw comprises a second thread, and the first and second threads are Acme threads.

84. The attachment system according to claim **78**, wherein the first screw comprises a substantially hollow interior portion, and at least a part of the second screw is configured to be positioned in the interior portion of the first screw in the clamped position.

85. The attachment system according to claim **84**, wherein the interior portion of the first screw comprises an interior thread configured to engage with the second thread of the second screw.

86. The attachment system according to claim **78**, wherein the first screw comprises a first thread oriented in a first direction, and the second screw comprises a second thread oriented in a second direction opposite from the first direction.

87. The attachment system according to claim **78**, further comprising a handle, whereby a rotation of the handle causes the second arm to move a distance proportional to an aggregate of a first lead of the first screw and a second lead of the second screw.

88. The attachment system according to claim **78**, wherein the second arm is further configured to be moved between a fully open and a fully closed position, the first and second arms being in contact in the fully closed position, and the first and second arms being separated by a distance in the fully open position, whereby about four rotations of the knob cause the second arm to move between the fully closed and fully open positions.

89. The attachment system according to claim **78**, wherein the structure comprises at least one of a pole and a bedrail.

90. The attachment system according to claim **78**, wherein the apparatus comprises a pump.

91. The attachment system according to claim **78**, wherein the apparatus comprises a negative pressure wound therapy (NPWT) apparatus.

92. The attachment system according to claim **91**, further comprising the NPWT apparatus, wherein the NPWT apparatus comprises a negative pressure source configured to be fluidically connected to a wound dressing, the wound dressing configured to be placed over a wound and to create a substantially fluid impermeable seal over the wound.

93. The attachment system according to claim **78**, wherein the cradle comprises the first arm, a housing, and a plurality of latches configured to be removably attached to the apparatus,

the first screw positioned at least partly within the housing of the cradle, and

the second screw positioned at least partly within the housing of the cradle, the second screw attached to the second arm via an opening in the second arm, the opening comprising a first interior thread configured to engage with the second thread of the second screw, the second screw comprising a substantially hollow interior portion comprising a second interior thread configured to engage with the first thread of the first screw so that at least a part of the first screw is configured to be positioned in the interior of the second screw in the clamped position.