



US 20220275654A1

(19) **United States**

(12) **Patent Application Publication**
CORMIER et al.

(10) **Pub. No.: US 2022/0275654 A1**

(43) **Pub. Date: Sep. 1, 2022**

(54) **LOAD DISTRIBUTION AND ABSORPTION UNDERLAYMENT SYSTEM WITH TRANSITION FEATURES**

E04H 9/06 (2006.01)
E01C 13/02 (2006.01)
E02B 3/06 (2006.01)
E04H 1/02 (2006.01)

(71) Applicant: **VICONIC SPORTING LLC**, Dearborn, MI (US)

(52) **U.S. Cl.**
CPC *E04F 15/225* (2013.01); *A47G 27/0231* (2013.01); *A47G 27/0218* (2013.01); *A47G 27/0287* (2013.01); *E04F 15/02038* (2013.01); *E04F 13/07* (2013.01); *E04H 3/08* (2013.01); *E04H 3/10* (2013.01); *E04H 5/00* (2013.01); *E04H 9/06* (2013.01); *E01C 13/02* (2013.01); *E02B 3/068* (2013.01); *E04H 1/02* (2013.01); *E04F 2290/044* (2013.01)

(72) Inventors: **Joel Matthew CORMIER**, Lathrup Village, MI (US); **Jackson Alexander ELLIOTT**, Plymouth, MI (US); **Richard Francois AUDI**, Dearborn, MI (US); **Donald Scott SMITH**, Commerce, MI (US)

(21) Appl. No.: **17/749,705**

(57) **ABSTRACT**

(22) Filed: **May 20, 2022**

A load distributing and absorbing system that lies below a barrier layer that is exposed to percussive and/or point-applied forces. The load distributing and absorbing system has one or more load distributing and absorbing tiles. At least some of the tiles have an underlayment infrastructure positioned below a barrier layer. The underlayment infrastructure includes one or more hat-shaped absorbing members. Each has a ceiling primarily for load distribution and a curvilinear wall primarily for load absorption extending from the ceiling. A transition feature is provided to smoothly graduate from one height and type of load distributing and absorbing tile to a load distributing and absorbing tile of another type and height. The system distributes and absorbs forces applied to the barrier layer over a broad area when applied either on a seam between adjacent tiles or within a tile.

Related U.S. Application Data

(62) Division of application No. 16/182,931, filed on Nov. 7, 2018.

Publication Classification

(51) **Int. Cl.**
E04F 15/22 (2006.01)
A47G 27/02 (2006.01)
E04F 15/02 (2006.01)
E04F 13/07 (2006.01)
E04H 3/08 (2006.01)
E04H 3/10 (2006.01)
E04H 5/00 (2006.01)

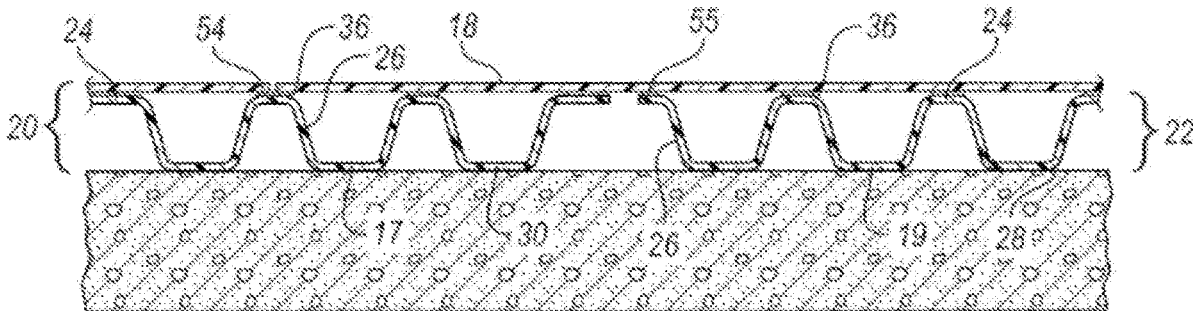

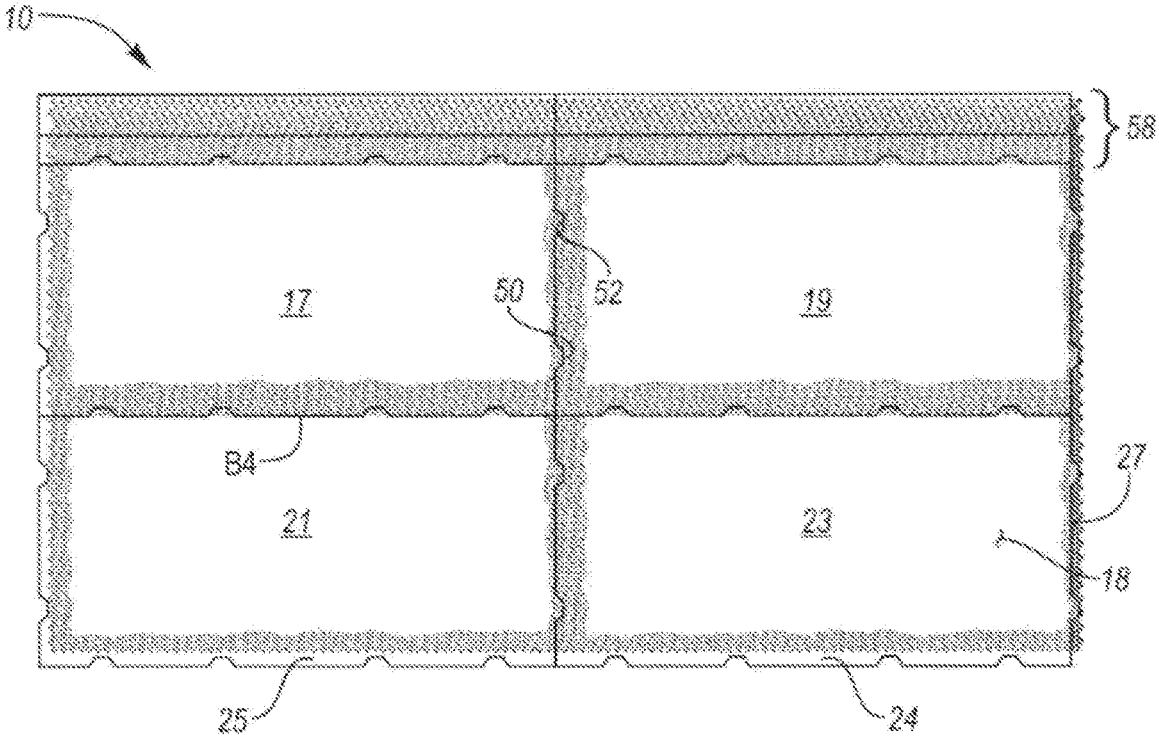

FIG. 1

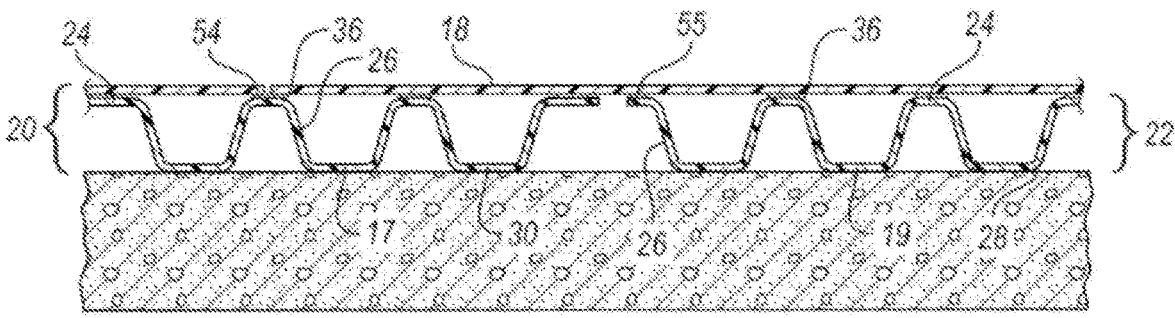

FIG. 2

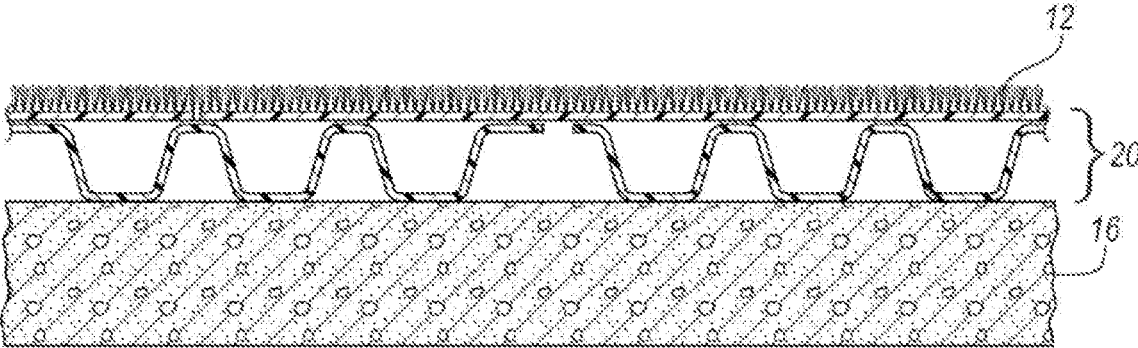

FIG. 3

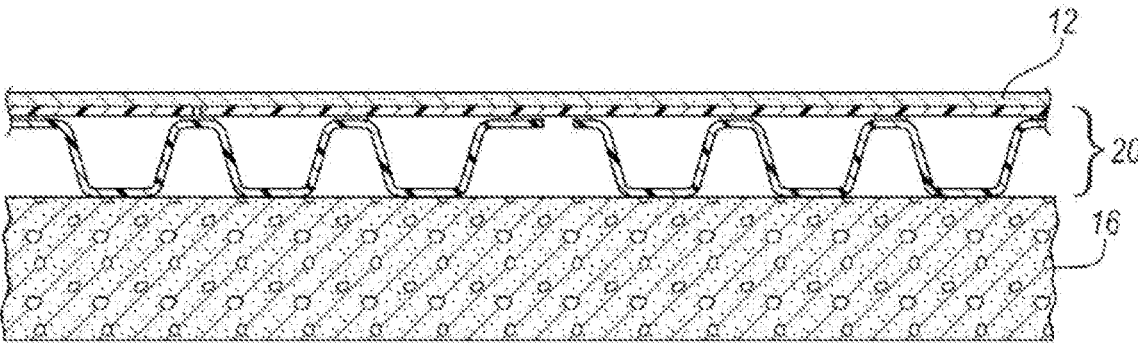

FIG. 4

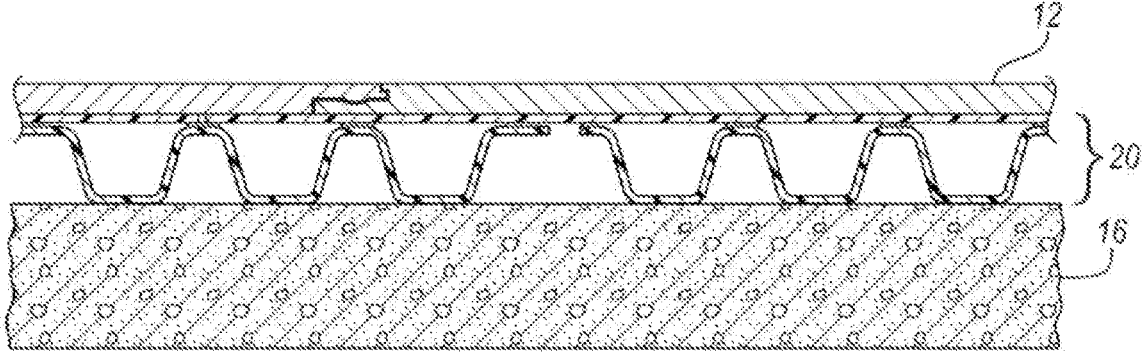

FIG. 5

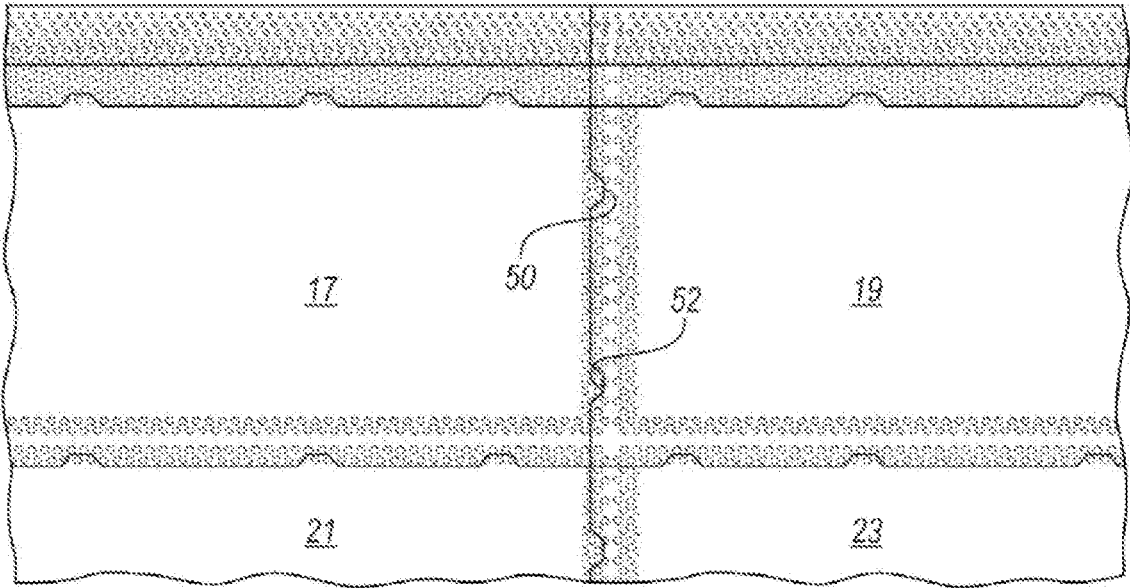

FIG. 6

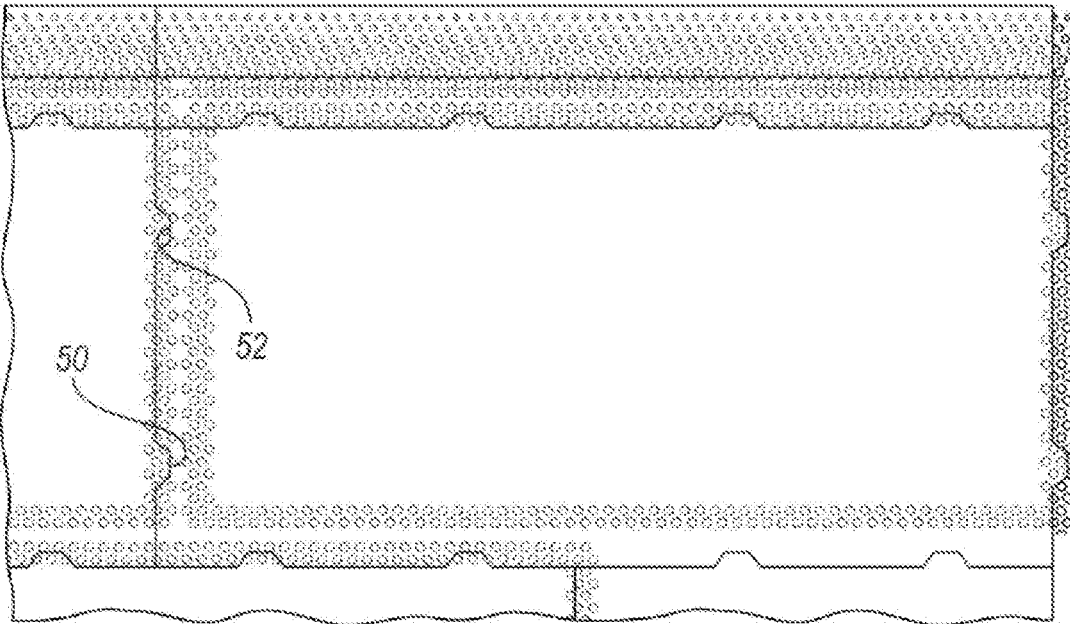

FIG. 7

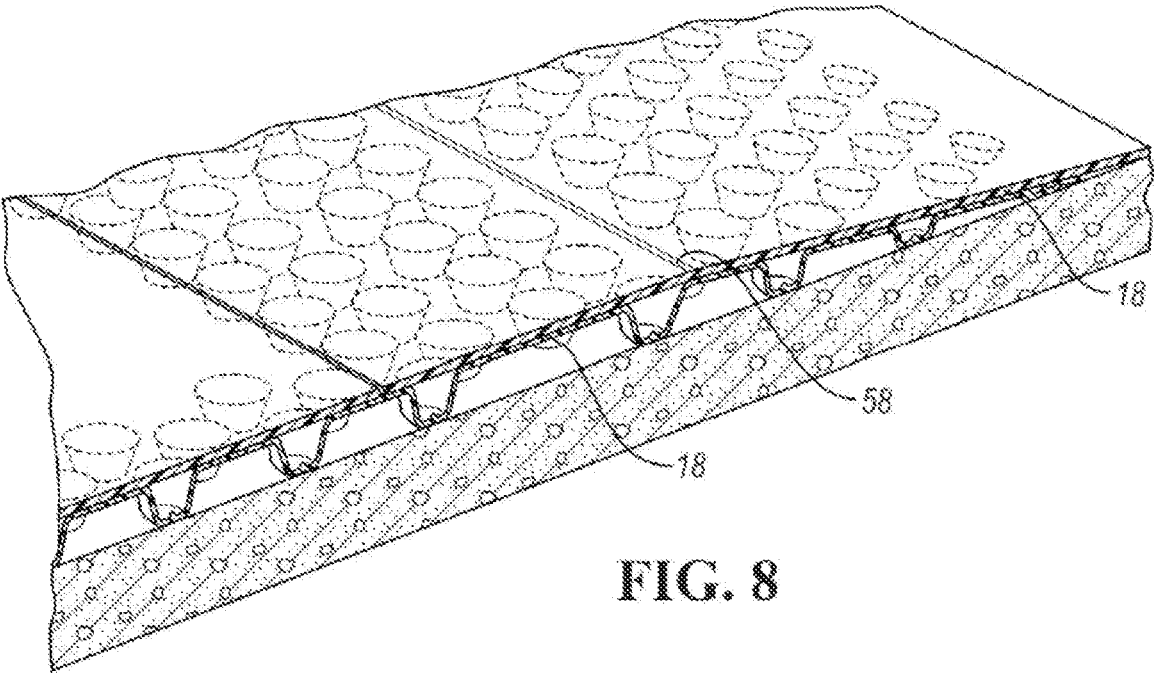

FIG. 8

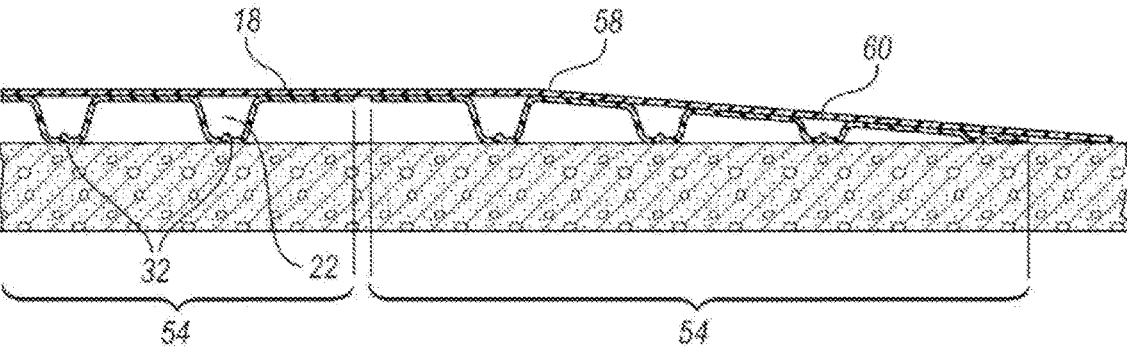

FIG. 9

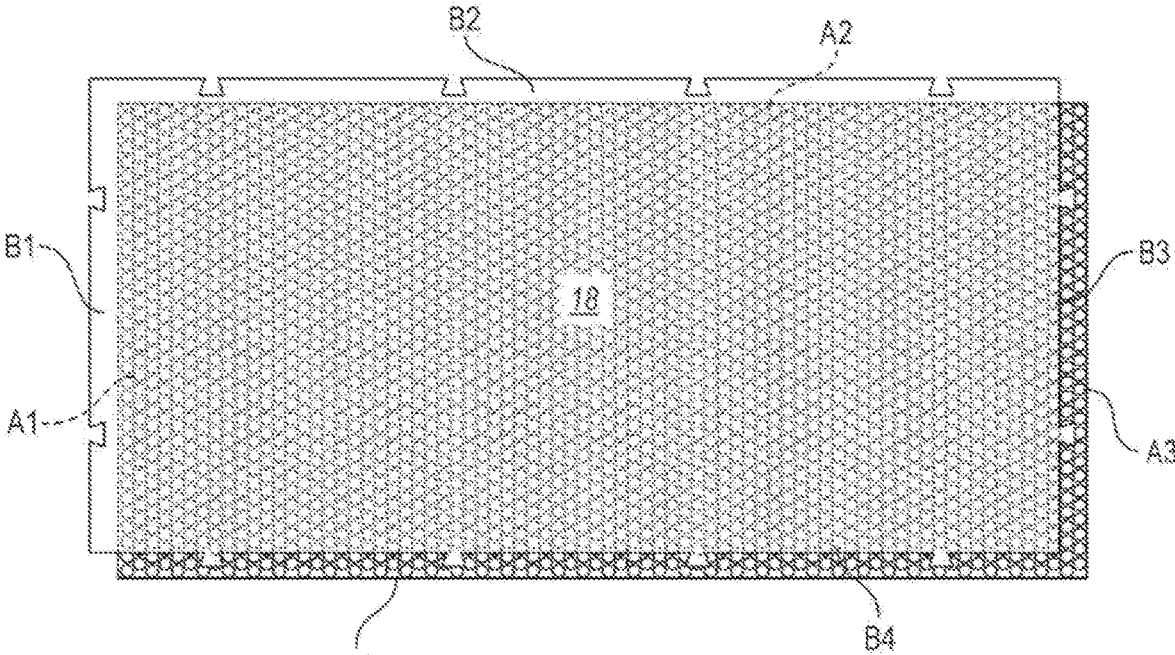

FIG. 10

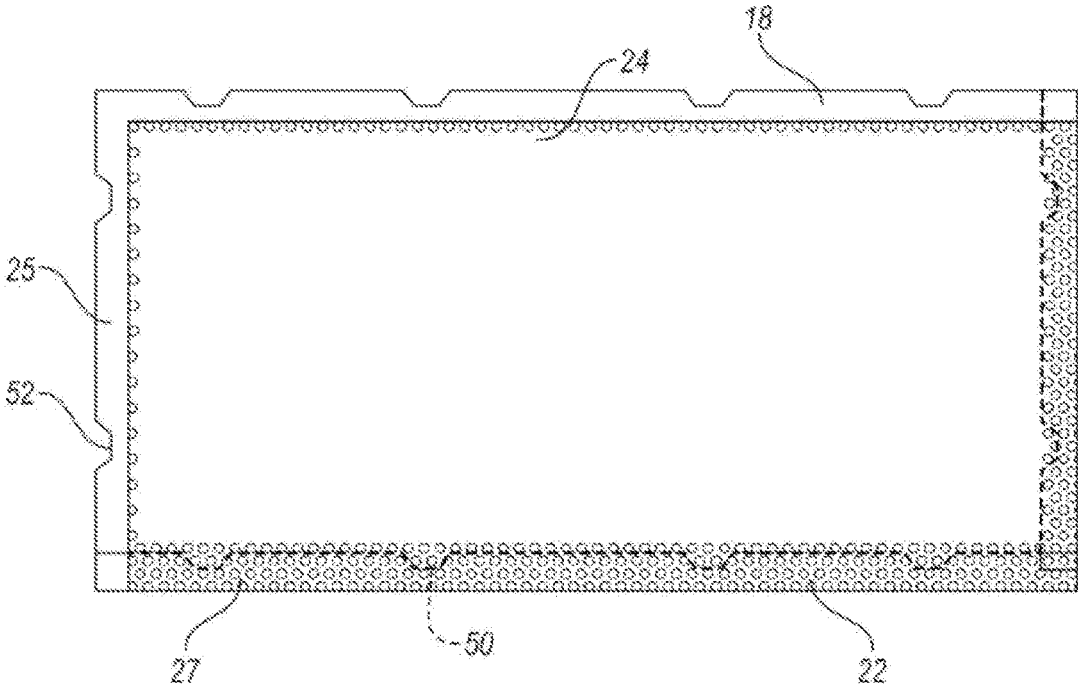

FIG. 11

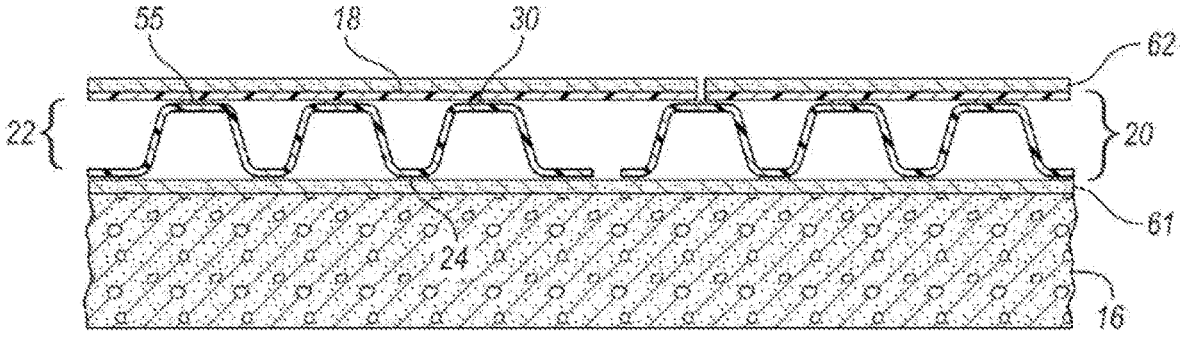

FIG. 12

LOAD DISTRIBUTION AND ABSORPTION UNDERLAYMENT SYSTEM WITH TRANSITION FEATURES

CROSS REFERENCE TO RELATED APPLICATIONS

[0001] This application is a division of U.S. application Ser. No. 16/182,931 filed Nov. 7, 2018, the disclosure of which is hereby incorporated in its entirety by reference herein.

[0002] This patent application is related to the following cases, the contents of which are incorporated by reference herein: U.S. Pat. No. 9,394,702 issued Jul. 19, 2016; U.S. Pat. No. 9,528,280 issued Dec. 27, 2016; U.S. Pat. No. 10,369,739 issued Aug. 6, 2019; U.S. Pat. No. 10,220,736 issued Mar. 5, 2019; and U.S. Pat. No. 10,788,091 issued Sep. 29, 2020.

BACKGROUND OF THE INVENTION

(1) Field of the Invention

[0003] Several aspects of this disclosure relate to a load distribution and absorption underlayment system with ties having transition features that bridge tiles of different heights, primarily for comfort underfoot and injury mitigation in such environments of use as an elder care or senior living facility.

(2) Background

[0004] Fall-related injuries among the ever-growing North American elderly population are a major health concern. In the United States, nearly 340,000 hip fractures occur per year, more than 90% of which are associated with falls. It is estimated that this number may double or triple by the middle of the century. The repercussions of hip fracture among the elderly add to the concern surrounding the issue. Over 25% of hip fracture patients over 65 years of age die within 1 year of the injury, and more than 50% suffer major declines in mobility and functional independence.

[0005] Traumatic brain injuries (TBI) also make up a significant portion of fall-related injuries; seniors are hospitalized twice as often as the general population for fall-related TBI. The incidence of fall-induced TBI and associated deaths has been rising at alarming rates, increasing by over 25% between 1989 and 1998. The risk for fall-related TBI increases substantially with age; persons over the age of 85 are hospitalized for fall-related TBI over twice as often as those aged 75-84, and over 6 times as often as those aged 65-74.

[0006] The financial burden associated with fall-related health care is significant. It is estimated the economic burden of fall-related injuries in Canada approximately \$2 billion in annual treatment costs and is expected to rise to about \$4.4 billion by 2031.

[0007] The costs to treat fall-related injuries in the United States are even higher. The average hospital cost for a fall injury in the US is over \$30,000, and in 2015, costs for falls to Medicare alone totaled over \$31 billion.

[0008] It would therefore be desirable to implement a surface, such as a flooring, underlayment system that will reduce impact forces and therefore reduce the potential risk of injury associated with fall-related impacts on the surface. Relatedly, it would be advantageous to have a low cost, low

profile, durable safety flooring underlayment system that is compatible with sheet vinyl and carpet. Potential benefits include reducing injury risk due to falls on the flooring surface, minimizing system cost, maintaining system durability, facilitating installation, abating noise while offering surface quality and comfort for both patients and caregivers.

[0009] Flooring system manufacturers offer a variety of products to the commercial and residential market. These products include ceramic tile, solid wood, wood composites, carpet in rolls, carpet tiles, sheet vinyl, flexible vinyl tiles, rigid vinyl tiles, rubber sheet, rubber tiles, and the like.

[0010] Commercial flooring systems are typically installed directly over subfloors comprised of either rigid plywood or concrete. These systems are engineered to either be adhered/affixed directly to the subfloor or to float over the subfloor without being affixed to the subfloor. Products commonly affixed to the subfloor include ceramic tiles, vinyl tiles, sheet vinyl, carpet tiles, rubber tiles, wood flooring, and rubber sheet goods. Products that commonly float over the subflooring system are typically rigid and include luxury vinyl tile, rigid wood composites and plastic flooring tiles.

[0011] Further, some flooring constructions add a second layer or underlayment between the subfloor and the flooring system to either increase force distribution, enhance comfort under foot, abate noise within the room and through the flooring, or provide some additional insulation. This second layer can either be affixed to subfloor or float depending upon the recommendation of the system manufacturer.

[0012] While such underlayment layers provide some added benefit, they also increase system cost, and installation complexity, and often reduce the durability of the top flooring material. To date, no commercially cost-effective and durable underlayment system has been developed that provides a substantial injury risk reduction due to falls on a variety of flooring products. Several attempts have been made and are summarized below, but such approaches often fail to meet certain performance and cost-effectiveness objectives.

[0013] Foams of various types have been considered for use in senior living facilities. However, these products are often so soft underfoot that they promote instability. This reaction may be significant to someone whose balance may be impaired. Additionally, such structures are prone to compression set due to their cellular nature and do not return to their original shape after sustaining a point static loading for long periods. Such loading may be imposed by a bed, chair, or another heavy object. The entire flooring system is expected to withstand the rigors of daily traffic over these surfaces.

[0014] Injection-molded molded tiles that snap into one another are often used for temporary or permanent flooring installations such as stage or dance floors, volleyball, basketball, garages, or another indoor flooring for sport surfaces. While the surfaces may be acceptable from an appearance standpoint, they offer little force distribution or comfort characteristics. Furthermore, they often contain moisture on or below the flooring surface. A water-tight system is unacceptable from a healthcare standpoint because there is a tendency for standing water to promote mold propagation, etc.

BRIEF SUMMARY OF THE INVENTION

[0015] Against this background, it would be desirable to develop a load distribution and absorption system that

would, especially in an elder care environment or the like, mitigate injuries and soften footfalls, while reducing noise and vibration where possible.

[0016] Ideally, such a system would be of relatively low cost and present a low profile with transition features to minimize tripping, yet be durable.

[0017] Among the goals are injury risk reduction due to falls on the flooring surface, minimizing system cost, maintaining system durability, facilitating installation, abating noise, yet retaining surface quality and comfort (in the case of elder care facilities) for patients and caregivers.

[0018] Accordingly, several embodiments of this disclosure include a load distributing and absorbing system that lies below a barrier layer that is exposed to continual or intermittent percussive forces. Often, such forces may cause a high localized pressure, such as when forces from a wheelchair are exerted via narrow wheels. The load distributing and absorbing system includes an underlayment infrastructure that is interposed between the barrier layer and a foundation below. In the underlayment infrastructure, load distribution is mainly provided by the barrier layer and load absorption is mainly provided by groups of absorbing members that are provided in tiles thereof (described below).

[0019] Most of the absorbing members have a ceiling which is positioned below the barrier layer. A continuous curvilinear wall plays a major role in energy absorption and extends from the ceiling. At the lower portion of the wall is a floor that lies above the foundation.

[0020] Tiles are united by the inter-engagement of overlapping barrier layers that overlie the ceilings of adjacent tiles. Where adjacent tiles have walls of different heights, overlapping portions of adjacent tiles provide a transition feature or smooth, relatively trip-free graduation for one tile to the next.

BRIEF DESCRIPTION OF THE SEVERAL VIEWS OF THE DRAWINGS

[0021] FIG. 1 is a top view of one embodiment of a load distributing and absorbing underlayment system that has four quadrilateral, preferably rectangular tiles.

[0022] FIG. 2 is a sectional view through two illustrative adjacent abutted tiles.

[0023] FIGS. 3-5 depict representative assembled flooring systems which include an underlayment infrastructure and a superstructure, such as three flooring products.

[0024] FIG. 6 shows a four-tile arrangement where adjacent tiles lie in the same orientation.

[0025] FIG. 7 suggests a three-seam intersection or staggered configuration of adjacent tiles.

[0026] FIG. 8 depicts an illustrative height transition member that transitions from a higher safety flooring system to another flooring product that is lower in average height.

[0027] FIG. 9 is a cross sectional view of one transition feature overlapping an adjacent tile.

[0028] FIG. 10 represents an alternative design of barrier layer mating registration features.

[0029] FIG. 11 illustrates a load distributing and absorbing system with a barrier layer where no adjacent tile exists and a pressure-sensitive adhesive is exposed on a tile edge.

[0030] FIG. 12 shows an alternative (inverted) embodiment.

DETAILED DESCRIPTION OF THE INVENTION

[0031] FIG. 1 is a top view of one embodiment of a load distributing and absorbing underlayment system 10 that has four quadrilateral, preferably rectangular, tiles 17, 19, 21, 23. These tiles are positioned relative to one another by inter-engaging mating registration features 50, 52, including male 50 and female 52 features provided along the edges of a barrier layer 18. Each tile 17, 19, 21, and 23 has an infrastructure 20 with a plurality of absorbing members 22 for load absorption and a barrier layer 18 for load distribution.

[0032] Consider FIG. 10. The barrier layer 18 (in this case) is quadrilateral with edges B1, B2, B3, and B4. A sub-assembly of underlying absorbing members 22 includes individual members 22 that are conjoined by their ceilings 24 which, before for example thermoforming take the form of a planar basal sheet. The absorbing members 22 join together and coordinate to form a periphery of the sub-assembly that is quadrilateral and has edges A1, A2, A3 and A4. Each barrier layer 18 is securely affixed to one or more of the ceilings 24 in a tile. In some cases, the barrier layer 18 is affixed to one or more of the ceilings 24 by means for securing 55 such as an adhesive or by mechanical means including screws, rivets, pins, and the like.

[0033] Edge B1 of the barrier layer 18 overhangs edge A1 of the sub-assembly of absorbing members 22 and edge B2 overhangs edge A2. Thus, edges A3 and A4 of the sub-assembly of absorbing members 22 extend beyond overlying edges B3 and B4 of the barrier layer 18. This arrangement creates an overhanging L-shaped platform 25 (FIGS. 1, 11) of the barrier layer 18 and an open L-shaped roof formed by the ceilings 24 of the absorbing members 22 in the sub-assembly. In adjacent tiles, the L-shaped roof 27 associated with a given tile 19 supports the L-shaped platform of the barrier layer 18 of an adjacent tile.

[0034] One consequence of this arrangement is that adjacent tiles engage each other in such a way as to inhibit relative lateral movement therebetween.

[0035] Interlocking engagement of adjacent tiles in a group is provided by mating registration features 50, 52 (FIGS. 1, 6, 7). In a preferred embodiment, these mating registration features 50, 52 are trapezoidal in shape. For example, a male trapezoid 50 abuts a female trapezoid 52 along the edges of adjacent tiles 17, 19, 21, 23. It will be appreciated that there are alternative shapes of mating registration features, such as keyholes, sawtooths, semi-circles, jigsaw-like pieces, etc.

[0036] FIG. 2 is a vertical sectional view through two illustrative adjacent abutted tiles, such as 17/19, 21/23, 17/21, 19/23 in FIG. 1. One version of an underlayment system 10 according to the present disclosure includes a barrier layer 18 which in some embodiments is in contact with the ceilings 24 of hat-shaped absorbing members 22.

[0037] As used herein the term "hat-shaped" includes frusto-conical. Such hat-shaped members 22 may have a lower portion 28 that has a footprint which is circular, oval, elliptical, a cloverleaf, a race track, or some other rounded shape with a curved perimeter. Similarly, for an upper portion 36 of an absorbing member 22. As used herein the term "hat-shaped" includes shapes that resemble those embodied in at least these hat styles: a boater/skimmer hat, a bowler/Derby hat, a bucket hat, a cloche hat, a fedora, a fez, a gambler hat, a homburg hat, a kettle brim or up-brim

hat, an outback or Aussie hat, a panama hat, a pith helmet, a porkpie hat, a top hat, a steam punk hat, a safari hat or a trilby hat. See, e.g., <https://www.hatsunlimited.com/hat-styles-guide>, which is incorporated by reference.

[0038] As used herein the terms “hat-shaped” and “frustoconical” exclude structures that include a ridge line or crease in a continuous curvilinear wall 26 associated with an absorbing member 22, because such features tend to promote stress concentration and lead to probable failure over time when exposed to percussive blows. They tend to concentrate, rather than distribute or absorb incident forces.

[0039] Connecting the ceiling 24 and the floor 30 of an absorbing member 22 is a curvilinear wall 26. When viewed laterally, a curvilinear wall 26 appears substantially linear or straight before being subjected to an impact force that may reign on a barrier layer 18. When viewed from above or below, the footprint of the lower portion 28 or upper portion 36 may appear circular, elliptical, oval, a clover leaf, a race-track or some other rounded shape with a curved perimeter.

[0040] The floor 30 or ceiling 24 of an absorbing member 22 may be flat or crenelated.

[0041] The absorbing members 22 may be manufactured from a resilient thermoplastic and be formed into frustoconical or hat-shaped members 22 that protrude from a sheet which before exposure to a forming process is substantially flat.

[0042] In one preferred embodiment, the barrier layer 18 is made from a strong thin layer of a polycarbonate (PC), the absorbing member 22 is made from a resilient thermoplastic polyurethane (TPU), and the means for securing 55 is provided by a pressure sensitive adhesive (PSA) which bonds well to both the PC and TPU.

[0043] Thus, an underlayment infrastructure 20 is created by the juxtaposition of a barrier layer 18 and a sub-assembly of absorbing members 22.

[0044] An assembly of absorbing members 22 and overlying barrier layer 18 forms a tile 17, 19, 21, 23 (FIG. 1). Adjacent tiles are inter-engaged by overlapping and underlapping edges of the barrier layer 18 in the manner described above. Preferably, a small, but acceptable, gap exists between barrier layers 18 associated with adjacent tiles. The barrier layer 18 of one tile overlaps at least some of the exposed absorbing members 22 of an adjacent tile.

[0045] If desired, an adhesive 55 (FIG. 2) can be applied to one or both surfaces prior to the application of pressure which then adhesively attaches a barrier layer 18 to a tile 17, 19, 21, 23. adjacent tiles. An underlayment infrastructure 20 is thus assembled when the edges of adjacent tiles are brought into registration through the inter-engagement of mating registration features 50, 52 of adjacent edges of associated barrier layers 18.

[0046] While a pressure sensitive adhesive is a preferred embodiment of means for securing 55 a barrier layer 18 to the ceilings 24 of a tile, alternatives for attaching overlapped tiles together through their associated barrier layers 18 include mechanical means for attaching such as Velcro®, tape, rivets, etc.

[0047] The overlap of the barrier layers 18 and proximity of the absorbing members 22 on adjacent tiles distributes a load applied to the barrier layer 18 over a broad area. Loads are evenly distributed when applied either on a seam between adjacent tiles or within a tile. Loads are at least

partially absorbed by flexure and possible rebound of the walls in the absorbing members.

[0048] FIGS. 3, 4 and 5 depict a representative assembled flooring system which includes the underlayment infrastructure 20 and three superstructure materials 12, such as flooring products. Those figures depict a section through a typical carpet system (FIG. 3), a sheet vinyl or rubber system (FIG. 4), and rigid wood or composite tiles (FIG. 5). Commercial carpet systems are most often bonded directly to a foundation 16 or subfloor or to an underlayment material using an adhesive. Sheet vinyl or rubber are typically adhesively bonded to the underlayment material. The rigid wood or composite tiles may or may not be adhesively bonded to the underlayment material, depending on the product recommendations.

[0049] FIGS. 6 and 7 show two different tile orientations. FIG. 6 shows a four-tile arrangement 17, 19, 21, 23 where adjacent tiles lie in the same orientation. This orientation is preferred as it minimizes the number of edge cuts when the installation site is rectangular. FIG. 7 suggests a three-seam intersection or staggered configuration of adjacent tiles. The periodicity of the male 50 and female features 52 in the barrier layer 18 are engineered such that the tiles can be staggered relative to one another to create a “T” seam (FIG. 7) as opposed to a seam in the four-tile intersection (FIG. 6). Both configurations contemplate overlapping the barrier layer 18 of one tile with another (see also, e.g., FIG. 2).

[0050] It will be appreciated that in some applications, a given sub-assembly 54 absorbing members 22 may have more than one overlying barrier layer 18.

[0051] A preferred embodiment of the finished tiles is a 5 ft×2.5 ft rectangular tile. Tiles of this size can be delivered to the job site on densely packed pallets. They fit through any doorway. Alternatively, any number of polygonal arrangements of tiles including hexagons and the like could form a load distribution and absorbing system 10. However, the four-sided structures are preferred to conform with rectangular rooms.

[0052] Flooring systems are rarely uniformly dimensioned or shaped throughout a facility. Flooring transitions from one product to another often require a transition feature 58 (FIGS. 8, 9) to smoothly graduate from one height and type of product to a product of another type and height. In some cases, sheet vinyl flooring is usually around 2 mm in thickness. But rigid products can be as high as 8 or 9 mm. Commercial carpet often lies somewhere in between sheet vinyl and rigid.

[0053] FIG. 8 shows an illustrative engineered height transition 58 that transitions from an 11 mm safety flooring system to another flooring product that is lower in height. The transition from 11 mm to 1 mm over a length of approximately 150 mm meets the Americans with Disabilities Act (ADA) requirements for wheelchairs.

[0054] FIG. 9 is a cross sectional view of one transition feature 58 overlapping an adjacent tile. In such cases, the transition has a barrier layer 18 extending across the tiles which overlaps adjacent sub-assemblies 54 of absorbing members 22 and provides a sloped section 60 (FIG. 9) to transition down to an alternative construction. While the transition feature 58 could be positioned almost anywhere within a flooring surface, these transitions would often occur near a doorway from one room to the next. For example, a facility may choose to deploy carpet and underlayment in a patient room for comfort and sheet vinyl with no underlay-

ment in a hallway. The transition feature **58** can be cut where the height matches the height of the adjacent flooring system.

[0055] In alternative embodiments, mating registration features **50**, **52** may resemble jigsaw puzzle pieces or rectangles. Overlap of a barrier layer over an adjacent tile of absorbing members is facilitated by a tight gap between adjacent tiles. This feature helps avoid soft spots or read through defects in form and appearance. FIG. **10** represents one alternative interlock design.

[0056] The absorbing members **22** may be made from various materials. In a preferred example, they may be thermoformed from a resilient thermoplastic polyurethane from a 0.5 mm to 2.0 mm base stock. Such units may have a curvilinear wall **26** with 5 to 45 degrees of draft and be 5-30 mm in height. Such constructions are primarily suitable for commercial applications.

[0057] Other environments of deployment, such as residential, may require less durability and resiliency since they experience relatively little wear. In such cases, the absorbing members **22** or the barrier layer **18** could be produced from other less resilient and less expensive thermoplastics such polyethylene, polypropylene, acrylonitrile butadiene styrene, polycarbonate and the like. Residential applications may require less durability and resiliency since they experience only a fraction of the force distribution. Additionally, a casting or injection molding process could also be deployed to produce a similar product or structure.

[0058] For commercial applications, barrier layer materials **18** are preferably made of polycarbonate between 0.5 mm and 2.0 mm in thickness with a surface texture.

[0059] Alternative approaches to affixing the superstructure material **12** to the barrier layer **18** or the barrier layer to the ceiling **24** of an absorbing member **22** through means for securing **34** will now be described. Styrene butadiene rubber and polypropylene-based pressure sensitive adhesive, like HB Fuller 2081, is preferred over other adhesive types based on its affinity for both PC and TPU layers. Pressure sensitive adhesive is preferred over other types of adhesive systems as it allows for adjacent tiles to be adhered to one another with a pre-applied adhesive that requires only pressure to activate. Unlike rigid thermosetting adhesive systems, the PSA remains pliable over the life of the system. However, other adhesives could be utilized to permanently or temporarily bond the layers together. The HB Fuller adhesive preferred is specific to the materials of construction and an alternative might be better suited to a different build of materials.

[0060] Other applications for the disclosed load distributing and absorbing system **10** exist. It will be appreciated that this disclosure is mainly focused on fall protection for older adults or infirm patients in areas where slips and falls are prone to occur. However, it is conceivable that the system could be used in other applications or environments of use beyond fall protection. As non-limiting examples, these include work mats, blast mats, boat matting, work platforms, anti-fatigue mats, enhanced comfort mats, wall protection, playgrounds, day care floors, residences, sports surfaces, and other surfaces where those in contact with the surface might benefit from the technology.

[0061] The system **10** can be enhanced by further layers that provide an added function. The barrier layer **18** may include an additional layer of PSA film for the attachment of a superstructure material **12** such as a flooring surface or an additional sound abatement layer such as rubber, cork, vinyl

barrier, and insulators. The absorbing members **22** may also have additional layers for sound abatement or adhesive.

[0062] In some cases, the load distributing and absorbing system **10** may benefit from the addition of a barrier layer **18** where no adjacent tile exists, and the PSA is exposed on a tile edge as in FIG. **10**. Adding these pieces would be most logical starting from a wall edge so that the first piece does not need to be trimmed back and a full tile can be installed without trimming.

[0063] Advantages of the disclosed load distributing and absorbing system include:

- [0064]** Military grade impact protection for seniors;
 - [0065]** Reduction in the risk of hip and other fractures due to falls;
 - [0066]** Reduction in the risk of traumatic brain injury due to falls;
 - [0067]** Reduction in fatigue with enhanced comfort under foot;
 - [0068]** Stability under foot when and where desired;
 - [0069]** Conformance of engineered transitions meet ADA accessibility requirements;
 - [0070]** Enhanced sound absorption;
 - [0071]** Enhanced vibration dampening;
 - [0072]** Low profile for renovation or new construction;
 - [0073]** Ease of installation;
 - [0074]** Compatibility with conventional flooring adhesives;
 - [0075]** Light weight;
 - [0076]** Affordable;
 - [0077]** Durable and capable of withstanding hundreds of impacts;
 - [0078]** Can be installed over green concrete;
 - [0079]** Provides additional thermal insulation;
 - [0080]** Incorporates post-industrial content;
 - [0081]** Acts as a vapor barrier.
- [0082]** Testing has demonstrated that use of various embodiments of the disclosed system may lead to a:
- [0083]** 20-fold reduction in risk of critical head injury
 - [0084]** 60% reduction in the probability of moderate head injury
 - [0085]** 3-fold reduction in GMAX
 - [0086]** 2.5-fold reduction femoral neck force during falls for average older females
 - [0087]** 3-fold increase in force reduction
 - [0088]** 2.5-fold reduction in energy restitution
 - [0089]** firm and stable and stable surface that supports mobility
 - [0090]** substantially more comfort under foot for caregivers and older adults.

[0091] Test data indicate that the proposed load distributing and absorbing systems have the potential to substantially reduce the risk of injury and improve the quality of life for both older adults and caregivers.

TABLE OF REFERENCE NUMBERS

Reference No.	Component
10	Load distributing and absorbing system
12	Superstructure material
14	Underside
16	Foundation
17	Tile
18	Barrier layer

-continued

TABLE OF REFERENCE NUMBERS

Reference No.	Component
19	Tile
20	Underlayment infrastructure
21	Tile
22	Absorbing members
23	Tile
24	Ceiling
25	Platform
26	Curvilinear wall
27	Roof
28	Lower portion
30	Floor
32	Apertures
34	Means for securing
36	Upper portion
38	Ceiling
40	Lower portion
42	Tiles of underlayment infrastructures
44	First tile
46	Edge
48	Adjacent tile
50	Male registration feature
52	Female registration feature
54	Sub-assemblies of absorbing members
55	Lower means for securing
56	Upper means for securing
58	Transition feature
60	Sloped section
61	Optional lower layer (e.g. sound or vibration dampening)
62	Optional upper layer

[0092] While exemplary embodiments are described above, it is not intended that these embodiments describe all possible forms of the invention. Rather, the words used in the specification are words of description rather than limitation, and it is understood that various changes may be made without departing from the spirit and scope of the invention. Additionally, the features of various implementing embodiments may be combined to form further embodiments of the invention.

What is claimed is:

1. A load distributing and absorbing system that lies below a barrier layer which is exposed to percussive forces, the load distributing and absorbing system being interposed between an underside of the barrier layer and a foundation below, the load distributing and absorbing system comprising:

a plurality of load distributing and absorbing tiles, at least some of the tiles having

an underlayment infrastructure positioned below the barrier layer, the underlayment infrastructure including

one or more hat-shaped absorbing members, at least some of the hat-shaped absorbing members having

a ceiling primarily for load distribution, the ceiling being positioned below the barrier layer;

a curvilinear wall primarily for load absorption extending from the ceiling, the curvilinear wall having a lower portion;

a floor that connects lower portions of the curvilinear wall of adjacent hat-shaped absorbing members, the floor lying above the foundation;

wherein the barrier layer of a first tile extends from two edges thereof and overhangs ceiling portions of two different adjacent tiles to create an L-shaped platform and promote inter-engagement of adjacent tiles without slippage,

a transition feature to smoothly graduate from one height and type of load distributing and absorbing tile to a load distributing and absorbing tile of another height and type,

wherein at least some tiles are joined together by mating registration features proximate the edges of the barrier layers, the mating registration features being defined by a male feature associated with an edge of a barrier layer that engages a female feature associated with an edge of a barrier layer in an adjacent tile, so that the overhang of the barrier layers and proximity of the absorbing members on adjacent tiles distribute a load applied to the barrier layer over a broad area, thereby distributing a load when applied either on a seam between adjacent tiles or within a tile.

2. The load distributing and absorbing system of claim 1 wherein an edge of the barrier layer defines the transition feature between tiles having different average heights of curvilinear walls.

3. The load distributing and absorbing system of claim 1 wherein the transition feature provides a sloped section to transition to a tile of different average wall height or product of a different height.

4. The load distributing and absorbing system wherein the transition feature of claim 1, including an underlayment infrastructure with curvilinear walls of progressively diminished height.

5. The load distributing and absorbing system of claim 1, wherein the barrier layer is selected from the group consisting of a ceramic tile, solid wood, a wood composite, a carpet, a carpet tile, sheet vinyl, a vinyl tile, a rigid vinyl tile, a rigid thermoplastic, a rubber sheet, and a rubber tile, a grating, and an anti-slip metallic surface.

6. The load distributing and absorbing system of claim 1, wherein the foundation includes concrete, a gravel, a metal and a hardwood.

7. The load distributing and absorbing system of claim 1, wherein at least some of the hat-shaped absorbing members have a configuration defined at least in part by an upper portion of a wall of an absorbing member that extends from a ceiling, a shape of the upper portion being selected from the group consisting of a circle, an oval, an ellipse, a cloverleaf, a race-track, and other curved perimeters.

8. The load distributing and absorbing system of claim 1, wherein at least some of the hat-shaped absorbing members have a configuration defined at least in part by an imaginary footprint defined by the lower portion of a wall adjacent to the floor, the footprint being selected from the group consisting of a circle, an oval, an ellipse, a cloverleaf, a race-track, and other curved perimeters.

9. The load distributing and absorbing infrastructure of claim 1, wherein

the barrier layer distributes at least some of the percussive forces, the barrier layer being quadrilateral with edges B1, B2, B3 and B4, the edges B1 and B2 including female registration features, the edges B3 and B4 including male registration features;

the absorbing member for absorbing at least some of the percussive forces is positioned at least partially below

the barrier layer, the absorbing member being quadrilateral and having edges A1, A2, A3 and A4, the absorbing member including hat-shaped energy absorbing units, at least some of the hat-shaped energy absorbing units having

a ceiling primarily for load distribution, the ceiling being positioned below the barrier layer;

a curvilinear wall primarily for load absorption, the curvilinear wall extending from the ceiling, the curvilinear wall having a lower portion;

and

a floor that connects facing sections of the curvilinear walls of adjacent hat-shaped energy absorbing units, the floor lying above the foundation, so that

edge B1 of the barrier layer overhangs edge A1 of the absorbing member and edge B2 overlies edge A2, thereby creating an L-shaped platform and edges A4 and A3 of the absorbing member extend beyond edges B4 and B3 of the barrier layer, thereby creating an L-shaped roof, the registration features of the barrier layer engaging corresponding registration features of the barrier layers of adjacent infrastructure tiles.

10. The load distributing and absorbing system of claim 1, wherein the ceiling between the walls of an absorbing member in a tile has a length that is less than a length of the floor between adjacent absorbing members in that tile.

11. The load distributing and absorbing system of claim 1, wherein the barrier layer includes a material selected from the group consisting of

a floor located in a senior living or elder care facility;

a hospital or out-patient facility;

an anti-fatigue mat;

an enhanced comfort mat;

a wall protection material;

a day care floor;

a flooring material in homes and residences; and

combinations thereof.

12. A load distributing and absorbing infrastructure tile in a load distributing and absorbing system that lies below a superstructure material that is exposed to percussive forces, the load distributing and absorbing infrastructure tile being interposed between the superstructure material and a foundation below, the load distributing and absorbing tile having

a barrier layer for distributing at least some of the percussive forces that lies below the superstructure mate-

rial and is quadrilateral with edges B1, B2, B3 and B4, the edges B1 and B2 including female trapezoidal registration features, the edges B3 and B4 including male trapezoidal registration features;

an absorbing member for absorbing at least some of the percussive forces that is positioned below the barrier layer, the absorbing member being quadrilateral and having edges A1, A2, A3 and A4, the absorbing member including hat-shaped energy absorbing units, at least some of the hat-shaped energy absorbing units having

a floor positioned below the barrier layer, the barrier layer being primarily for load distribution;

a curvilinear wall primarily for load absorption, the curvilinear wall extending from the floor, the curvilinear wall having a lower portion;

and

a ceiling lying above the foundation, the ceiling connecting facing sections of the curvilinear wall of adjacent hat-shaped energy absorbing units, wherein the barrier layer is secured to an absorbing member so that

edge B1 of the barrier layer overlies edge A1 of the absorbing member and edge B2 of the barrier layer overlies edge A2 of the absorbing member, creating

an L-shaped platform and a transition feature between tiles of differing heights of curvilinear wall;

edges A4 and A3 of the absorbing member extend beyond respective edges B4 and B3 of the barrier layer,

edges A3 and A4 creating an L-shaped roof,

the L-shaped platform having registration features that engage corresponding registration features of adjacent L-shaped platforms, so that the overhang of the barrier layers and proximity of the absorbing members on adjacent tiles distribute a load applied to the barrier layer over a broad area, thereby distributing a percussive or point-applied load when exerted either on a seam between adjacent tiles or within a tile, regardless of wall height in adjacent tiles.

13. The load distributing and absorbing system of claim 1, wherein the transition feature extends from about 11 mm down to about 1 mm over a length of about 150 mm and thus meets Americans with Disabilities Act (ADA) requirements for wheelchairs.

* * * * *