



US011464628B2

(12) **United States Patent**
Vidlund et al.

(10) **Patent No.:** **US 11,464,628 B2**

(45) **Date of Patent:** **Oct. 11, 2022**

(54) **EXPANDABLE EPICARDIAL PADS AND DEVICES AND METHODS FOR DELIVERY OF SAME**

(71) Applicant: **Tendyne Holdings, Inc.**, St. Paul, MN (US)

(72) Inventors: **Robert M. Vidlund**, Forest Lake, MN (US); **Igor Kovalsky**, Minnetonka, MN (US); **Zachary J. Tegels**, Minneapolis, MN (US); **Craig A. Ekvall**, East Bethel, MN (US)

(73) Assignee: **Tendyne Holdings, Inc.**, St. Paul, MN (US)

(*) Notice: Subject to any disclaimer, the term of this patent is extended or adjusted under 35 U.S.C. 154(b) by 463 days.

(21) Appl. No.: **16/788,382**

(22) Filed: **Feb. 12, 2020**

(65) **Prior Publication Data**
US 2020/0179111 A1 Jun. 11, 2020

Related U.S. Application Data

(60) Division of application No. 15/654,374, filed on Jul. 19, 2017, now Pat. No. 10,610,356, which is a (Continued)

(51) **Int. Cl.**
A61F 2/24 (2006.01)
A61B 17/04 (2006.01)
A61B 17/34 (2006.01)

(52) **U.S. Cl.**
CPC *A61F 2/2418* (2013.01); *A61B 17/0401* (2013.01); *A61F 2/2433* (2013.01); (Continued)

(58) **Field of Classification Search**
CPC *A61F 2/2418*; *A61F 2/2433*; *A61F 2/2439*; *A61F 2/2436*; *A61F 2250/0098*; (Continued)

(56) **References Cited**

U.S. PATENT DOCUMENTS

2,697,008 A 12/1954 Ross
3,409,013 A 11/1968 Berry
(Continued)

FOREIGN PATENT DOCUMENTS

CN 1486161 A 3/2004
CN 1961845 A 5/2007
(Continued)

OTHER PUBLICATIONS

US 9,155,620 B2, 10/2015, Gross et al. (withdrawn)
(Continued)

Primary Examiner — Julian W Woo

(74) *Attorney, Agent, or Firm* — Wei & Sleman LLP

(57) **ABSTRACT**

Apparatus and methods are described herein for use in the delivery of a prosthetic mitral valve. In some embodiments, an apparatus includes an epicardial pad configured to engage an outside surface of a heart to secure a prosthetic heart valve in position within the heart. The epicardial pad defines a lumen configured to receive therethrough a tether extending from the prosthetic valve. The epicardial pad is movable between a first configuration in which the epicardial pad has a first outer perimeter and is configured to be disposed within a lumen of a delivery sheath and a second configuration in which the epicardial pad has a second outer perimeter greater than the first outer perimeter. The epicardial pad can be disposed against the outside surface of the heart when in the second configuration to secure the prosthetic valve and tether in a desired position within the heart.

6 Claims, 61 Drawing Sheets

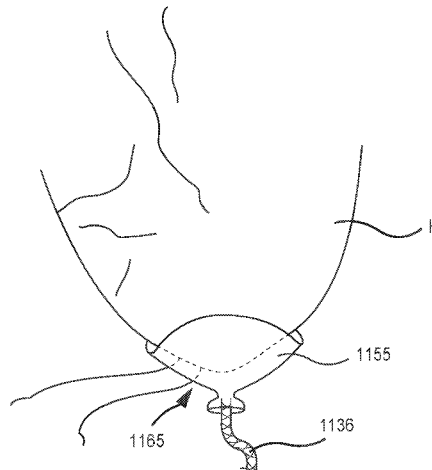

Related U.S. Application Data

- continuation of application No. PCT/US2016/016567, filed on Feb. 4, 2016, which is a continuation-in-part of application No. PCT/US2015/014572, filed on Feb. 5, 2015.
- (60) Provisional application No. 62/212,803, filed on Sep. 1, 2015, provisional application No. 62/100,548, filed on Jan. 7, 2015, provisional application No. 61/935,899, filed on Feb. 5, 2014.
- (52) **U.S. Cl.**
 CPC *A61F 2/2436* (2013.01); *A61F 2/2439* (2013.01); *A61B 2017/0443* (2013.01); *A61B 2017/3425* (2013.01); *A61F 2/2457* (2013.01); *A61F 2220/0016* (2013.01); *A61F 2220/0041* (2013.01); *A61F 2220/0075* (2013.01); *A61F 2220/0083* (2013.01); *A61F 2230/0093* (2013.01); *A61F 2250/0039* (2013.01); *A61F 2250/0063* (2013.01); *A61F 2250/0098* (2013.01)
- (58) **Field of Classification Search**
 CPC *A61F 2250/0063*; *A61F 2250/0039*; *A61F 2230/0093*; *A61F 2220/0083*; *A61F 2220/0075*; *A61F 2220/0041*; *A61F 2220/0016*; *A61F 2/2457*; *A61B 17/0401*; *A61B 2017/3425*; *A61B 2017/0443*
 See application file for complete search history.

(56) **References Cited**

U.S. PATENT DOCUMENTS

3,472,230 A 10/1969 Fogarty et al.
 3,476,101 A 11/1969 Ross
 3,548,417 A 12/1970 Kischer
 3,587,115 A 6/1971 Shiley
 3,657,744 A 4/1972 Ersek
 3,671,979 A 6/1972 Mouloupoulos
 3,714,671 A 2/1973 Edwards et al.
 3,755,823 A 9/1973 Hancock
 3,976,079 A 8/1976 Samuels et al.
 4,003,382 A 1/1977 Dyke
 4,035,849 A 7/1977 Angell et al.
 4,056,854 A 11/1977 Boretos et al.
 4,073,438 A 2/1978 Meyer
 4,106,129 A 8/1978 Carpentier et al.
 4,222,126 A 9/1980 Boretos et al.
 4,265,694 A 5/1981 Boretos et al.
 4,297,749 A 11/1981 Davis et al.
 4,339,831 A 7/1982 Johnson
 4,343,048 A 8/1982 Ross et al.
 4,345,340 A 8/1982 Rosen
 4,373,216 A 2/1983 Klawitter
 4,406,022 A 9/1983 Roy
 4,470,157 A 9/1984 Love
 4,490,859 A 1/1985 Black et al.
 4,535,483 A 8/1985 Klawitter et al.
 4,574,803 A 3/1986 Storz
 4,585,705 A 4/1986 Broderick et al.
 4,592,340 A 6/1986 Boyles
 4,605,407 A 8/1986 Black et al.
 4,612,011 A 9/1986 Kautzky
 4,626,255 A 12/1986 Reichart et al.
 4,638,886 A 1/1987 Marietta
 4,643,732 A 2/1987 Pietsch et al.
 4,655,771 A 4/1987 Wallsten
 4,692,164 A 9/1987 Dzemeshkevich et al.
 4,733,665 A 3/1988 Palmaz
 4,759,758 A 7/1988 Gabbay
 4,762,128 A 8/1988 Rosenbluth
 4,777,951 A 10/1988 Cribier et al.
 4,787,899 A 11/1988 Lazarus

4,787,901 A 11/1988 Baykut
 4,796,629 A 1/1989 Grayzel
 4,824,180 A 4/1989 Levrai
 4,829,990 A 5/1989 Thuroff et al.
 4,830,117 A 5/1989 Capasso
 4,851,001 A 7/1989 Taheri
 4,856,516 A 8/1989 Hillstead
 4,878,495 A 11/1989 Grayzel
 4,878,906 A 11/1989 Lindemann et al.
 4,883,458 A 11/1989 Shiber
 4,922,905 A 5/1990 Streckler
 4,923,013 A 5/1990 De Gennaro
 4,960,424 A 10/1990 Grooters
 4,966,604 A 10/1990 Reiss
 4,979,939 A 12/1990 Shiber
 4,986,830 A 1/1991 Owens et al.
 4,994,077 A 2/1991 Dobben
 4,996,873 A 3/1991 Takeuchi
 5,007,896 A 4/1991 Shiber
 5,026,366 A 6/1991 Leckrone
 5,032,128 A 7/1991 Alonso
 5,035,706 A 7/1991 Giantureo et al.
 5,037,434 A 8/1991 Lane
 5,047,041 A 9/1991 Samuels
 5,059,177 A 10/1991 Towne et al.
 5,064,435 A 11/1991 Porter
 5,080,668 A 1/1992 Bolz et al.
 5,085,635 A 2/1992 Cragg
 5,089,015 A 2/1992 Ross
 5,152,771 A 10/1992 Sabbaghian et al.
 5,163,953 A 11/1992 Vince
 5,167,628 A 12/1992 Boyles
 5,192,297 A 3/1993 Hull
 5,201,880 A 4/1993 Wright et al.
 5,266,073 A 11/1993 Wall
 5,282,847 A 2/1994 Trescony et al.
 5,295,958 A 3/1994 Shturman
 5,306,296 A 4/1994 Wright et al.
 5,332,402 A 7/1994 Teitelbaum
 5,336,616 A 8/1994 Livesey et al.
 5,344,442 A 9/1994 Deac
 5,360,444 A 11/1994 Kusuvara
 5,364,407 A 11/1994 Poll
 5,370,685 A 12/1994 Stevens
 5,397,351 A 3/1995 Pavcnik et al.
 5,411,055 A 5/1995 Kane
 5,411,552 A 5/1995 Andersen et al.
 5,415,667 A 5/1995 Frater
 5,443,446 A 8/1995 Shturman
 5,480,424 A 1/1996 Cox
 5,500,014 A 3/1996 Quijano et al.
 5,545,209 A 8/1996 Roberts et al.
 5,545,214 A 8/1996 Stevens
 5,549,665 A 8/1996 Vesely et al.
 5,554,184 A 9/1996 Machiraju
 5,554,185 A 9/1996 Block et al.
 5,571,175 A 11/1996 Vanney et al.
 5,591,185 A 1/1997 Kilmer et al.
 5,607,462 A 3/1997 Imran
 5,607,464 A 3/1997 Trescony et al.
 5,609,626 A 3/1997 Quijano et al.
 5,639,274 A 6/1997 Fischell et al.
 5,662,704 A 9/1997 Gross
 5,665,115 A 9/1997 Cragg
 5,674,279 A 10/1997 Wright et al.
 5,697,905 A 12/1997 d'Ambrosio
 5,702,368 A 12/1997 Stevens et al.
 5,716,417 A 2/1998 Girard et al.
 5,728,068 A 3/1998 Leone et al.
 5,728,151 A 3/1998 Garrison et al.
 5,735,842 A 4/1998 Krueger et al.
 5,741,333 A 4/1998 Frid
 5,749,890 A 5/1998 Shaknovich
 5,756,476 A 5/1998 Epstein et al.
 5,769,812 A 6/1998 Stevens et al.
 5,792,179 A 8/1998 Sideris
 5,800,508 A 9/1998 Goicoechea et al.
 5,833,673 A 11/1998 Ockuly et al.
 5,840,081 A 11/1998 Andersen et al.

(56)

References Cited

U.S. PATENT DOCUMENTS

5,855,597	A	1/1999	Jayaraman	6,810,882	B2	11/2004	Langberg et al.
5,855,601	A	1/1999	Bessler et al.	6,830,584	B1	12/2004	Seguin
5,855,602	A	1/1999	Angell	6,854,668	B2	2/2005	Wancho et al.
5,904,697	A	5/1999	Gifford, III et al.	6,855,144	B2	2/2005	Lesh
5,925,063	A	7/1999	Khosravi	6,858,001	B1	2/2005	Aboul-Hosn
5,957,949	A	9/1999	Leonhardt et al.	6,890,353	B2	5/2005	Cohn et al.
5,968,052	A	10/1999	Sullivan, III et al.	6,893,460	B2	5/2005	Spenser et al.
5,968,068	A	10/1999	Dehdashtian et al.	6,896,690	B1	5/2005	Lambrecht et al.
5,972,030	A	10/1999	Garrison et al.	6,908,424	B2	6/2005	Mortier et al.
5,993,481	A	11/1999	Marcade et al.	6,908,481	B2	6/2005	Cribier
6,027,525	A	2/2000	Suh et al.	6,936,067	B2	8/2005	Buchanan
6,042,607	A	3/2000	Williamson, IV et al.	6,945,996	B2	9/2005	Sedransk
6,045,497	A	4/2000	Schweich, Jr. et al.	6,955,175	B2	10/2005	Stevens et al.
6,063,112	A	5/2000	Sgro	6,974,476	B2	12/2005	McGuckin, Jr. et al.
6,077,214	A	6/2000	Mortier et al.	6,976,543	B1	12/2005	Fischer
6,099,508	A	8/2000	Bousquet	6,997,950	B2	2/2006	Chawla
6,132,473	A	10/2000	Williams et al.	7,018,406	B2	3/2006	Seguin et al.
6,168,614	B1	1/2001	Andersen et al.	7,018,408	B2	3/2006	Bailey et al.
6,171,335	B1	1/2001	Wheatley et al.	7,044,905	B2	5/2006	Vidlund et al.
6,174,327	B1	1/2001	Mertens et al.	7,060,021	B1	6/2006	Wilk
6,183,411	B1	2/2001	Mortier et al.	7,077,862	B2	7/2006	Vidlund et al.
6,210,408	B1	4/2001	Chandrasekaran et al.	7,087,064	B1	8/2006	Hyde
6,217,585	B1	4/2001	Houser et al.	7,100,614	B2	9/2006	Stevens et al.
6,221,091	B1	4/2001	Khosravi	7,101,395	B2	9/2006	Tremulis et al.
6,231,602	B1	5/2001	Carpentier et al.	7,108,717	B2	9/2006	Freidberg
6,245,102	B1	6/2001	Jayaraman	7,112,219	B2	9/2006	Vidlund et al.
6,260,552	B1	7/2001	Mortier et al.	7,115,141	B2	10/2006	Menz et al.
6,261,222	B1	7/2001	Schweich, Jr. et al.	7,141,064	B2	11/2006	Scott et al.
6,264,602	B1	7/2001	Mortier et al.	7,175,656	B2	2/2007	Khairkahan
6,287,339	B1	9/2001	Vazquez et al.	7,198,646	B2	4/2007	Figulla et al.
6,299,637	B1	10/2001	Shaolian et al.	7,201,772	B2	4/2007	Schwammenthal et al.
6,302,906	B1	10/2001	Goicoechea et al.	7,247,134	B2	7/2007	Vidlund et al.
6,312,465	B1	11/2001	Griffin et al.	7,252,682	B2	8/2007	Seguin
6,332,893	B1	12/2001	Mortier et al.	7,267,686	B2	9/2007	DiMatteo et al.
6,350,277	B1	2/2002	Kocur	7,275,604	B1	10/2007	Wall
6,358,277	B1	3/2002	Duran	7,276,078	B2	10/2007	Spenser et al.
6,379,372	B1	4/2002	Dehdashtian et al.	7,276,084	B2	10/2007	Yang et al.
6,402,679	B1	6/2002	Mortier et al.	7,316,706	B2	1/2008	Bloom et al.
6,402,680	B2	6/2002	Mortier et al.	7,318,278	B2	1/2008	Zhang et al.
6,402,781	B1	6/2002	Langberg et al.	7,326,236	B2	2/2008	Andreas et al.
6,406,420	B1	6/2002	McCarthy et al.	7,329,278	B2	2/2008	Seguin et al.
6,425,916	B1	7/2002	Garrison et al.	7,331,991	B2	2/2008	Kheradvar et al.
6,440,164	B1	8/2002	DiMatteo et al.	7,335,213	B1	2/2008	Hyde et al.
6,454,799	B1	9/2002	Schreck	7,361,137	B2	4/2008	Taylor et al.
6,458,153	B1	10/2002	Bailey et al.	7,374,571	B2	5/2008	Pease et al.
6,461,382	B1	10/2002	Cao	7,377,941	B2	5/2008	Rhee et al.
6,468,660	B2	10/2002	Ogle et al.	7,381,210	B2	6/2008	Zarbatany et al.
6,482,228	B1	11/2002	Norred	7,381,218	B2	6/2008	Schreck
6,488,704	B1	12/2002	Connelly et al.	7,393,360	B2	7/2008	Spenser et al.
6,537,198	B1	3/2003	Vidlund et al.	7,404,824	B1	7/2008	Webler et al.
6,540,782	B1	4/2003	Snyders	7,416,554	B2	8/2008	Lam et al.
6,569,196	B1	5/2003	Vesely	7,422,072	B2	9/2008	Dade
6,575,252	B2	6/2003	Reed	7,429,269	B2	9/2008	Schwammenthal et al.
6,582,462	B1	6/2003	Andersen et al.	7,442,204	B2	10/2008	Schwammenthal et al.
6,605,112	B1	8/2003	Moll et al.	7,445,631	B2	11/2008	Salahieh et al.
6,616,684	B1	9/2003	Vidlund et al.	7,462,191	B2	12/2008	Spenser et al.
6,622,730	B2	9/2003	Ekvall et al.	7,470,285	B2	12/2008	Nugent et al.
6,629,534	B1	10/2003	St. Goar et al.	7,500,989	B2	3/2009	Solem et al.
6,629,921	B1	10/2003	Schweich, Jr. et al.	7,503,931	B2	3/2009	Kowalsky et al.
6,648,077	B2	11/2003	Hoffman	7,510,572	B2	3/2009	Gabbay
6,648,921	B2	11/2003	Anderson et al.	7,510,575	B2	3/2009	Spenser et al.
6,652,578	B2	11/2003	Bailey et al.	7,513,908	B2	4/2009	Lattouf
6,669,724	B2	12/2003	Park et al.	7,524,330	B2	4/2009	Berrekouw
6,706,065	B2	3/2004	Langberg et al.	7,527,647	B2	5/2009	Spence
6,709,456	B2	3/2004	Langberg et al.	7,534,260	B2	5/2009	Lattouf
6,723,038	B1	4/2004	Schroeder et al.	7,556,646	B2	7/2009	Yang et al.
6,726,715	B2	4/2004	Sutherland	7,579,381	B2	8/2009	Dove
6,730,118	B2	5/2004	Spenser et al.	7,585,321	B2	9/2009	Cribier
6,733,525	B2	5/2004	Yang et al.	7,591,847	B2	9/2009	Navia et al.
6,740,105	B2	5/2004	Yodfat et al.	7,618,446	B2	11/2009	Andersen et al.
6,746,401	B2	6/2004	Panescu	7,618,447	B2	11/2009	Case et al.
6,746,471	B2	6/2004	Mortier et al.	7,618,449	B2	11/2009	Tremulis et al.
6,752,813	B2	6/2004	Goldfarb et al.	7,621,948	B2	11/2009	Herrmann et al.
6,764,510	B2	7/2004	Vidlund et al.	7,632,304	B2	12/2009	Park
6,797,002	B2	9/2004	Spence et al.	7,632,308	B2	12/2009	Loulmet
				7,635,386	B1	12/2009	Gammie
				7,674,222	B2	3/2010	Nikolic et al.
				7,674,286	B2	3/2010	Alfieri et al.
				7,695,510	B2	4/2010	Bloom et al.

(56)

References Cited

U.S. PATENT DOCUMENTS

7,708,775	B2	5/2010	Rowe et al.	8,986,376	B2	3/2015	Solem
7,748,389	B2	7/2010	Salahieh et al.	9,011,522	B2	4/2015	Annest
7,766,961	B2	8/2010	Patel et al.	9,023,099	B2	5/2015	Duffy et al.
7,783,366	B1	8/2010	Morgan et al.	9,034,032	B2	5/2015	McLean et al.
7,789,909	B2	9/2010	Andersen et al.	9,034,033	B2	5/2015	McLean et al.
7,803,168	B2	9/2010	Gifford et al.	9,039,757	B2	5/2015	McLean et al.
7,803,184	B2	9/2010	McGuckin, Jr. et al.	9,039,759	B2	5/2015	Alkhatib et al.
7,803,185	B2	9/2010	Gabbay	9,078,645	B2	7/2015	Conklin et al.
7,806,928	B2	10/2010	Rowe et al.	9,078,749	B2	7/2015	Lutter et al.
7,837,727	B2	11/2010	Goetz et al.	9,084,676	B2	7/2015	Chau et al.
7,854,762	B2	12/2010	Speziali et al.	9,095,433	B2	8/2015	Lutter et al.
7,892,281	B2	2/2011	Seguin et al.	9,125,742	B2	9/2015	Yoganathan et al.
7,896,915	B2	3/2011	Guyenot et al.	9,149,357	B2	10/2015	Seguin
7,901,454	B2	3/2011	Kapadia et al.	9,161,837	B2	10/2015	Kapadia
7,927,370	B2	4/2011	Webler et al.	9,168,137	B2	10/2015	Subramanian et al.
7,931,630	B2	4/2011	Nishtala et al.	9,232,995	B2	1/2016	Kovalsky et al.
7,942,928	B2	5/2011	Webler et al.	9,232,998	B2	1/2016	Wilson et al.
7,955,247	B2	6/2011	Levine et al.	9,232,999	B2	1/2016	Maurer et al.
7,955,385	B2	6/2011	Crittenden	9,241,702	B2	1/2016	Maisano et al.
7,972,378	B2	7/2011	Tabor et al.	9,254,192	B2	2/2016	Lutter et al.
7,988,727	B2	8/2011	Santamore et al.	9,265,608	B2	2/2016	Miller et al.
7,993,394	B2	8/2011	Hariton et al.	9,289,295	B2	3/2016	Aklog et al.
8,007,992	B2	8/2011	Tian et al.	9,289,297	B2	3/2016	Wilson et al.
8,029,556	B2	10/2011	Rowe	9,345,573	B2	5/2016	Nyuli et al.
8,043,368	B2	10/2011	Crabtree	9,468,526	B2	10/2016	Subramanian et al.
8,052,749	B2	11/2011	Salahieh et al.	9,480,557	B2	11/2016	Pellegrini et al.
8,052,750	B2	11/2011	Tuval et al.	9,480,559	B2	11/2016	Vidlund et al.
8,052,751	B2	11/2011	Aklog et al.	9,526,611	B2	12/2016	Tegels et al.
8,062,355	B2	11/2011	Figulla et al.	9,597,181	B2	3/2017	Christianson et al.
8,062,359	B2	11/2011	Marquez et al.	9,610,159	B2	4/2017	Christianson et al.
8,070,802	B2	12/2011	Lamphere et al.	9,675,454	B2	6/2017	Vidlund et al.
8,109,996	B2	2/2012	Stacchino et al.	9,730,792	B2	8/2017	Lutter et al.
8,142,495	B2	3/2012	Hasenkam et al.	9,827,092	B2	11/2017	Vidlund et al.
8,152,821	B2	4/2012	Gambale et al.	9,833,315	B2	12/2017	Vidlund et al.
8,157,810	B2	4/2012	Case et al.	9,848,880	B2	12/2017	Coleman et al.
8,167,932	B2	5/2012	Bourang et al.	9,867,700	B2	1/2018	Bakis et al.
8,167,934	B2	5/2012	Styrc et al.	9,883,941	B2	2/2018	Hastings et al.
8,187,299	B2	5/2012	Goldfarb et al.	9,895,221	B2	2/2018	Vidlund
8,206,439	B2	6/2012	Gomez Duran	9,986,993	B2	6/2018	Vidlund et al.
8,216,301	B2	7/2012	Bonhoeffer et al.	10,016,271	B2	7/2018	Morriss et al.
8,226,711	B2	7/2012	Mortier et al.	10,226,334	B2	3/2019	Rowe et al.
8,236,045	B2	8/2012	Benichou et al.	2001/0018611	A1	8/2001	Solem et al.
8,241,274	B2	8/2012	Keogh et al.	2001/0021872	A1	9/2001	Bailey et al.
8,252,051	B2	8/2012	Chau et al.	2001/0025171	A1	9/2001	Mortier et al.
8,303,653	B2	11/2012	Bonhoeffer et al.	2002/0010427	A1	1/2002	Scarfone et al.
8,308,796	B2	11/2012	Lashinski et al.	2002/0116054	A1	8/2002	Lundell et al.
8,323,334	B2	12/2012	Deem et al.	2002/0139056	A1	10/2002	Finnell
8,353,955	B2	1/2013	Styrc et al.	2002/0151961	A1	10/2002	Lashinski et al.
RE44,075	E	3/2013	Williamson et al.	2002/0161377	A1	10/2002	Rabkin
8,449,599	B2	5/2013	Chau et al.	2002/0173842	A1	11/2002	Buchanan
8,454,656	B2	6/2013	Tuval	2002/0183827	A1	12/2002	Derus et al.
8,470,028	B2	6/2013	Thornton et al.	2003/0010509	A1	1/2003	Hoffman
8,480,730	B2	7/2013	Maurer et al.	2003/0036698	A1	2/2003	Kohler et al.
8,486,138	B2	7/2013	Vesely	2003/0050694	A1	3/2003	Yang et al.
8,506,623	B2	8/2013	Wilson et al.	2003/0069593	A1	4/2003	Tremulis et al.
8,506,624	B2	8/2013	Vidlund et al.	2003/0078652	A1	4/2003	Sutherland
8,556,963	B2	10/2013	Tremulis et al.	2003/0100939	A1	5/2003	Yodfat et al.
8,578,705	B2	11/2013	Sindano et al.	2003/0105519	A1	6/2003	Fasol et al.
8,579,913	B2	11/2013	Nielsen	2003/0105520	A1	6/2003	Alferness et al.
8,591,573	B2	11/2013	Barone	2003/0120340	A1	6/2003	Liska et al.
8,591,576	B2	11/2013	Hasenkam et al.	2003/0130731	A1	7/2003	Vidlund et al.
8,597,347	B2	12/2013	Maurer et al.	2003/0149476	A1	8/2003	Damm et al.
8,685,086	B2	4/2014	Navia et al.	2003/0212454	A1	11/2003	Scott et al.
8,790,394	B2	7/2014	Miller et al.	2004/0039436	A1	2/2004	Spenser et al.
8,845,717	B2	9/2014	Khairkhahan et al.	2004/0049211	A1	3/2004	Tremulis et al.
8,888,843	B2	11/2014	Khairkhahan et al.	2004/0049266	A1	3/2004	Anduiza et al.
8,900,214	B2	12/2014	Nance et al.	2004/0064014	A1	4/2004	Melvin et al.
8,900,295	B2	12/2014	Migliazza et al.	2004/0092858	A1	5/2004	Wilson et al.
8,926,696	B2	1/2015	Cabiri et al.	2004/0093075	A1	5/2004	Kuehne
8,932,342	B2	1/2015	McHugo et al.	2004/0097865	A1	5/2004	Anderson et al.
8,932,348	B2	1/2015	Solem et al.	2004/0127983	A1	7/2004	Mortier et al.
8,945,208	B2	2/2015	Jimenez et al.	2004/0133263	A1	7/2004	Dusbabek et al.
8,956,407	B2	2/2015	Macoviak et al.	2004/0147958	A1	7/2004	Lam et al.
8,961,597	B2	2/2015	Subramanian et al.	2004/0152947	A1	8/2004	Schroeder et al.
8,979,922	B2	3/2015	Jayasinghe et al.	2004/0162610	A1	8/2004	Liska et al.
				2004/0163828	A1	8/2004	Silverstein et al.
				2004/0181239	A1	9/2004	Dorn et al.
				2004/0186565	A1	9/2004	Schreck
				2004/0186566	A1	9/2004	Hindrichs et al.

(56)

References Cited

U.S. PATENT DOCUMENTS

2004/0210304	A1	10/2004	Seguin et al.	2007/0078297	A1	4/2007	Rafiee et al.
2004/0260317	A1	12/2004	Bloom et al.	2007/0083076	A1	4/2007	Lichtenstein
2004/0260389	A1	12/2004	Case et al.	2007/0083259	A1	4/2007	Bloom et al.
2005/0004652	A1	1/2005	van der Burg et al.	2007/0093890	A1	4/2007	Eliassen et al.
2005/0004666	A1	1/2005	Altieri et al.	2007/0100439	A1	5/2007	Cangialosi et al.
2005/0075727	A1	4/2005	Wheatley	2007/0112422	A1	5/2007	Dehdashtian
2005/0080402	A1	4/2005	Santamore et al.	2007/0112425	A1	5/2007	Schaller et al.
2005/0085900	A1	4/2005	Case et al.	2007/0118151	A1	5/2007	Davidson
2005/0096498	A1	5/2005	Houser et al.	2007/0118154	A1	5/2007	Crabtree
2005/0107661	A1	5/2005	Lau et al.	2007/0118210	A1	5/2007	Pinchuk
2005/0113798	A1	5/2005	Slater et al.	2007/0118213	A1	5/2007	Loulmet
2005/0113810	A1	5/2005	Houser et al.	2007/0142906	A1	6/2007	Figulla et al.
2005/0113811	A1	5/2005	Houser et al.	2007/0161846	A1	7/2007	Nikolic et al.
2005/0119519	A9	6/2005	Girard et al.	2007/0162048	A1	7/2007	Quinn et al.
2005/0121206	A1	6/2005	Dolan	2007/0162103	A1	7/2007	Case et al.
2005/0125012	A1	6/2005	Houser et al.	2007/0168024	A1	7/2007	Khairkahan
2005/0137686	A1	6/2005	Salahieh et al.	2007/0173931	A1	7/2007	Tremulis et al.
2005/0137688	A1	6/2005	Salahieh et al.	2007/0185565	A1	8/2007	Schwammenthal et al.
2005/0137695	A1	6/2005	Salahieh et al.	2007/0185571	A1	8/2007	Kapadia et al.
2005/0137698	A1	6/2005	Salahieh et al.	2007/0203575	A1	8/2007	Forster et al.
2005/0148815	A1	7/2005	Mortier et al.	2007/0213813	A1	9/2007	Von Segesser et al.
2005/0177180	A1	8/2005	Kaganov et al.	2007/0215362	A1	9/2007	Rodgers
2005/0197695	A1	9/2005	Stacchino et al.	2007/0221388	A1	9/2007	Johnson
2005/0203614	A1	9/2005	Forster et al.	2007/0233239	A1	10/2007	Navia et al.
2005/0203615	A1	9/2005	Forster et al.	2007/0239265	A1	10/2007	Birdsall
2005/0203617	A1	9/2005	Forster et al.	2007/0256843	A1	11/2007	Pahila
2005/0234546	A1	10/2005	Nugent et al.	2007/0265658	A1	11/2007	Nelson et al.
2005/0240200	A1	10/2005	Bergheim	2007/0267202	A1	11/2007	Mariller
2005/0251157	A1	11/2005	Saadat et al.	2007/0270932	A1	11/2007	Headley et al.
2005/0251209	A1	11/2005	Saadat et al.	2007/0270943	A1	11/2007	Solem et al.
2005/0256567	A1	11/2005	Lim et al.	2007/0293944	A1	12/2007	Spenser et al.
2005/0283231	A1	12/2005	Haug et al.	2008/0009940	A1	1/2008	Cribier
2005/0288766	A1	12/2005	Plain et al.	2008/0033543	A1	2/2008	Gurskis et al.
2006/0004442	A1	1/2006	Spenser et al.	2008/0065011	A1	3/2008	Marchand et al.
2006/0025784	A1	2/2006	Starksen et al.	2008/0071361	A1	3/2008	Tuval et al.
2006/0025857	A1	2/2006	Bergheim et al.	2008/0071362	A1	3/2008	Tuval et al.
2006/0030885	A1	2/2006	Hyde	2008/0071363	A1	3/2008	Tuval et al.
2006/0042803	A1	3/2006	Gallaher	2008/0071366	A1	3/2008	Tuval et al.
2006/0047338	A1	3/2006	Jenson et al.	2008/0071368	A1	3/2008	Tuval et al.
2006/0052868	A1	3/2006	Mortier et al.	2008/0071369	A1	3/2008	Tuval et al.
2006/0058872	A1	3/2006	Salahieh et al.	2008/0082163	A1	4/2008	Woo
2006/0074397	A1	4/2006	Shimada	2008/0082166	A1	4/2008	Styrc et al.
2006/0074484	A1	4/2006	Huber	2008/0091264	A1	4/2008	Machold et al.
2006/0094983	A1	5/2006	Burbank et al.	2008/0109069	A1	5/2008	Coleman et al.
2006/0129025	A1	6/2006	Levine et al.	2008/0114442	A1	5/2008	Mitchell et al.
2006/0142784	A1	6/2006	Kontos	2008/0125861	A1	5/2008	Webler et al.
2006/0161040	A1	7/2006	McCarthy et al.	2008/0140189	A1	6/2008	Nguyen et al.
2006/0161249	A1	7/2006	Realyvasquez et al.	2008/0147179	A1	6/2008	Cai et al.
2006/0167541	A1	7/2006	Lattouf	2008/0154355	A1	6/2008	Benichou et al.
2006/0195134	A1	8/2006	Crittenden	2008/0154356	A1	6/2008	Obermiller et al.
2006/0195183	A1	8/2006	Navia et al.	2008/0161911	A1	7/2008	Revuelta et al.
2006/0196137	A1	9/2006	Brenzel et al.	2008/0172035	A1	7/2008	Starksen et al.
2006/0229708	A1	10/2006	Powell et al.	2008/0177381	A1	7/2008	Navia et al.
2006/0229719	A1	10/2006	Marquez et al.	2008/0183203	A1	7/2008	Fitzgerald et al.
2006/0241745	A1	10/2006	Solem	2008/0183273	A1	7/2008	Mesana et al.
2006/0247491	A1	11/2006	Vidlund et al.	2008/0188928	A1	8/2008	Salahieh et al.
2006/0252984	A1	11/2006	Rahdert et al.	2008/0208328	A1	8/2008	Antocci et al.
2006/0259135	A1	11/2006	Navia et al.	2008/0208332	A1	8/2008	Lamphere et al.
2006/0259136	A1	11/2006	Nguyen et al.	2008/0221672	A1	9/2008	Lamphere et al.
2006/0259137	A1	11/2006	Artof et al.	2008/0228263	A1	9/2008	Ryan
2006/0276874	A1	12/2006	Wilson et al.	2008/0243150	A1	10/2008	Starksen et al.
2006/0282161	A1	12/2006	Huynh et al.	2008/0243245	A1	10/2008	Thambar et al.
2006/0287716	A1	12/2006	Banbury et al.	2008/0255660	A1	10/2008	Guyenot et al.
2006/0287717	A1	12/2006	Rowe et al.	2008/0255661	A1	10/2008	Straubinger et al.
2007/0005131	A1	1/2007	Taylor	2008/0281411	A1	11/2008	Berrekouw
2007/0005231	A1	1/2007	Seguchi	2008/0288060	A1	11/2008	Kaye et al.
2007/0010877	A1	1/2007	Salahieh et al.	2008/0293996	A1	11/2008	Evans et al.
2007/0016286	A1	1/2007	Herrmann et al.	2008/0300678	A1	12/2008	Eidenschink et al.
2007/0016288	A1	1/2007	Gurskis et al.	2009/0005863	A1	1/2009	Goetz et al.
2007/0027535	A1	2/2007	Purdy et al.	2009/0048668	A1	2/2009	Wilson et al.
2007/0038291	A1	2/2007	Case et al.	2009/0054968	A1	2/2009	Bonhoeffer et al.
2007/0050020	A1	3/2007	Spence	2009/0054974	A1	2/2009	McGuckin, Jr. et al.
2007/0061010	A1	3/2007	Hauser et al.	2009/0062908	A1	3/2009	Bonhoeffer et al.
2007/0066863	A1	3/2007	Rafiee et al.	2009/0076598	A1	3/2009	Salahieh et al.
2007/0073387	A1	3/2007	Forster et al.	2009/0082619	A1	3/2009	De Marchena
				2009/0088836	A1	4/2009	Bishop et al.
				2009/0099410	A1	4/2009	De Marchena
				2009/0112309	A1	4/2009	Jaramillo et al.
				2009/0131849	A1	5/2009	Maurer et al.

(56)

References Cited

U.S. PATENT DOCUMENTS

2009/0132035	A1	5/2009	Roth et al.	2011/0288637	A1	11/2011	De Marchena
2009/0137861	A1	5/2009	Goldberg et al.	2011/0319988	A1	12/2011	Schankerele et al.
2009/0138079	A1	5/2009	Tuval et al.	2011/0319989	A1	12/2011	Lane et al.
2009/0157175	A1	6/2009	Benichou	2012/0010694	A1	1/2012	Lutter et al.
2009/0164005	A1	6/2009	Dove et al.	2012/0010700	A1	1/2012	Spenser
2009/0171432	A1	7/2009	Von Segesser et al.	2012/0016468	A1	1/2012	Robin et al.
2009/0171447	A1	7/2009	Von Segesser et al.	2012/0022640	A1	1/2012	Gross et al.
2009/0171456	A1	7/2009	Kveen et al.	2012/0035703	A1	2/2012	Lutter et al.
2009/0177266	A1	7/2009	Powell et al.	2012/0035713	A1	2/2012	Lutter et al.
2009/0182417	A1	7/2009	Tremulis et al.	2012/0035722	A1	2/2012	Tuval
2009/0192601	A1	7/2009	Rafiee et al.	2012/0053686	A1	3/2012	McNamara et al.
2009/0210047	A1	8/2009	Amplatz et al.	2012/0059487	A1	3/2012	Cunanan et al.
2009/0210052	A1	8/2009	Forster et al.	2012/0089171	A1	4/2012	Hastings et al.
2009/0216322	A1	8/2009	Le et al.	2012/0101571	A1	4/2012	Thambar et al.
2009/0222076	A1	9/2009	Figulla et al.	2012/0101572	A1	4/2012	Kovalsky et al.
2009/0224529	A1	9/2009	Gill	2012/0109079	A1	5/2012	Asleson et al.
2009/0234318	A1	9/2009	Loulmet et al.	2012/0116351	A1	5/2012	Chomas et al.
2009/0234435	A1	9/2009	Johnson et al.	2012/0123529	A1	5/2012	Levi et al.
2009/0234443	A1	9/2009	Ottma et al.	2012/0158129	A1	6/2012	Duffy et al.
2009/0240320	A1	9/2009	Tuval et al.	2012/0165930	A1	6/2012	Gifford, III et al.
2009/0248149	A1	10/2009	Gabbay	2012/0179244	A1	7/2012	Schankerele et al.
2009/0276038	A1	11/2009	Tremulis et al.	2012/0203336	A1	8/2012	Annest
2009/0276040	A1	11/2009	Rowe et al.	2012/0215303	A1	8/2012	Quadri et al.
2009/0281619	A1	11/2009	Le et al.	2012/0226348	A1	9/2012	Lane et al.
2009/0287299	A1	11/2009	Tabor et al.	2012/0245678	A1	9/2012	Solem
2009/0292262	A1	11/2009	Adams et al.	2012/0283824	A1	11/2012	Lutter et al.
2009/0319037	A1	12/2009	Rowe et al.	2012/0289945	A1	11/2012	Segermark
2009/0326575	A1	12/2009	Galdonik et al.	2013/0030522	A1	1/2013	Rowe et al.
2010/0004740	A1	1/2010	Seguin et al.	2013/0053950	A1	2/2013	Rowe et al.
2010/0016958	A1	1/2010	St. Goar et al.	2013/0066341	A1	3/2013	Ketai et al.
2010/0021382	A1	1/2010	Dorshow et al.	2013/0079873	A1	3/2013	Migliazza et al.
2010/0023117	A1	1/2010	Yoganathan et al.	2013/0103140	A1	4/2013	Subramanian et al.
2010/0036479	A1	2/2010	Hill et al.	2013/0131788	A1	5/2013	Quadri et al.
2010/0049313	A1	2/2010	Alon et al.	2013/0172978	A1	7/2013	Vidlund et al.
2010/0082094	A1	4/2010	Quadri et al.	2013/0184811	A1	7/2013	Rowe et al.
2010/0121435	A1	5/2010	Subramanian et al.	2013/0190860	A1	7/2013	Sundt, III
2010/0121437	A1	5/2010	Subramanian et al.	2013/0190861	A1	7/2013	Chau et al.
2010/0161041	A1	6/2010	Maisano et al.	2013/0197622	A1	8/2013	Mitra et al.
2010/0168839	A1	7/2010	Braido et al.	2013/0226288	A1	8/2013	Goldwasser et al.
2010/0179641	A1	7/2010	Ryan et al.	2013/0226290	A1	8/2013	Yellin et al.
2010/0185277	A1	7/2010	Braido et al.	2013/0231735	A1	9/2013	Deem et al.
2010/0185278	A1	7/2010	Schankerele	2013/0274874	A1	10/2013	Hammer
2010/0191326	A1	7/2010	Alkhatib	2013/0282101	A1	10/2013	Eidenschink et al.
2010/0192402	A1	8/2010	Yamaguchi et al.	2013/0304200	A1	11/2013	McLean et al.
2010/0204781	A1	8/2010	Alkhatib	2013/0310928	A1	11/2013	Morriss et al.
2010/0210899	A1	8/2010	Schankerele	2013/0317603	A1	11/2013	McLean et al.
2010/0217382	A1	8/2010	Chau et al.	2013/0325041	A1	12/2013	Annest et al.
2010/0249489	A1	9/2010	Jarvik	2013/0325110	A1	12/2013	Khalil et al.
2010/0249923	A1	9/2010	Alkhatib et al.	2013/0338752	A1	12/2013	Geusen et al.
2010/0280589	A1	11/2010	Stycr	2013/0338764	A1	12/2013	Thornton et al.
2010/0280604	A1	11/2010	Zipory et al.	2014/0005778	A1	1/2014	Buchbinder et al.
2010/0286768	A1	11/2010	Alkhatib	2014/0031924	A1	1/2014	Bruchman et al.
2010/0298755	A1	11/2010	McNamara et al.	2014/0046433	A1	2/2014	Kovalsky
2010/0298931	A1	11/2010	Quadri et al.	2014/0081323	A1	3/2014	Hawkins
2011/0004296	A1	1/2011	Lutter et al.	2014/0094918	A1	4/2014	Vishnubholta et al.
2011/0015616	A1	1/2011	Straubinger et al.	2014/0142691	A1	5/2014	Pouletty
2011/0015728	A1	1/2011	Jimenez et al.	2014/0163668	A1	6/2014	Rafiee
2011/0015729	A1	1/2011	Jimenez et al.	2014/0194981	A1	7/2014	Menk et al.
2011/0022157	A1	1/2011	Essinger et al.	2014/0194983	A1	7/2014	Kovalsky et al.
2011/0029072	A1	2/2011	Gabbay	2014/0214159	A1	7/2014	Vidlund et al.
2011/0066231	A1	3/2011	Cartledge et al.	2014/0222142	A1	8/2014	Kovalsky et al.
2011/0066233	A1	3/2011	Thornton et al.	2014/0243857	A1	8/2014	Miller et al.
2011/0112632	A1	5/2011	Chau et al.	2014/0243965	A1	8/2014	Benson et al.
2011/0137397	A1	6/2011	Chau et al.	2014/0243966	A1	8/2014	Garde et al.
2011/0137408	A1	6/2011	Bergheim	2014/0257466	A1	9/2014	Board et al.
2011/0213459	A1	9/2011	Garrison et al.	2014/0277419	A1	9/2014	Garde et al.
2011/0218619	A1	9/2011	Benichou et al.	2014/0296969	A1	10/2014	Tegels et al.
2011/0224655	A1	9/2011	Asirvatham et al.	2014/0296970	A1	10/2014	Ekvall et al.
2011/0224678	A1	9/2011	Gabbay	2014/0296971	A1	10/2014	Tegels et al.
2011/0224728	A1	9/2011	Martin et al.	2014/0296972	A1	10/2014	Tegels et al.
2011/0224784	A1	9/2011	Quinn	2014/0296975	A1	10/2014	Tegels et al.
2011/0245911	A1	10/2011	Quill et al.	2014/0303718	A1	10/2014	Tegels et al.
2011/0251682	A1	10/2011	Murray, III et al.	2014/0309732	A1	10/2014	Solem
2011/0264191	A1	10/2011	Rothstein	2014/0316516	A1	10/2014	Vidlund et al.
2011/0264206	A1	10/2011	Tabor	2014/0324160	A1	10/2014	Benichou et al.
				2014/0324161	A1	10/2014	Tegels et al.
				2014/0324164	A1	10/2014	Gross et al.
				2014/0331475	A1	11/2014	Duffy et al.
				2014/0358222	A1	12/2014	Gorman, III et al.

(56)

References Cited

U.S. PATENT DOCUMENTS

2014/0358224	A1	12/2014	Tegels et al.	2017/0312077	A1	11/2017	Vidlund et al.
2014/0364942	A1	12/2014	Straubinger et al.	2017/0319333	A1	11/2017	Tegels et al.
2014/0364944	A1	12/2014	Lutter et al.	2017/0325842	A1	11/2017	Siegel
2014/0379076	A1	12/2014	Vidlund et al.	2018/0028314	A1	2/2018	Ekvall et al.
2015/0005874	A1	1/2015	Vidlund et al.	2018/0078368	A1	3/2018	Vidlund et al.
2015/0011821	A1	1/2015	Gorman et al.	2018/0078370	A1	3/2018	Kovalsky et al.
2015/0025553	A1	1/2015	Del Nido et al.	2018/0147055	A1	5/2018	Vidlund et al.
2015/0057705	A1	2/2015	Vidlund	2018/0193138	A1	7/2018	Vidlund
2015/0073542	A1	3/2015	Heldman	2018/0296212	A1	10/2018	Jimenez et al.
2015/0073545	A1	3/2015	Braido	2019/0167407	A1	6/2019	Schaer et al.
2015/0094802	A1	4/2015	Buchbinder et al.	2020/0179111	A1	6/2020	Vidlund et al.
2015/0105856	A1	4/2015	Rowe et al.				
2015/0119936	A1	4/2015	Gilmore et al.	CN	2902226	Y	5/2007
2015/0119978	A1	4/2015	Tegels et al.	CN	101146484	A	3/2008
2015/0127093	A1	5/2015	Hosmer et al.	CN	101180010	A	5/2008
2015/0127096	A1	5/2015	Rowe et al.	CN	101484093		7/2009
2015/0134050	A1	5/2015	Solem et al.	CN	101180010		12/2010
2015/0142100	A1	5/2015	Morriss et al.	CN	101984938	A	3/2011
2015/0142101	A1	5/2015	Coleman et al.	CN	102639179	A	8/2012
2015/0142103	A1	5/2015	Mdlund	CN	102791223	A	11/2012
2015/0142104	A1	5/2015	Braido	CN	102869317	A	1/2013
2015/0173897	A1	6/2015	Raanani et al.	CN	102869318	A	1/2013
2015/0196393	A1	7/2015	Vidlund et al.	CN	102869321	A	1/2013
2015/0196688	A1	7/2015	James	CN	103220993	A	7/2013
2015/0202044	A1	7/2015	Chau et al.	CN	103974674	A	8/2014
2015/0216653	A1	8/2015	Freudenthal	CN	102639179	B	10/2014
2015/0216660	A1	8/2015	Pintor	CN	104941016		9/2015
2015/0223820	A1	8/2015	Olson	DE	2246526	A1	3/1973
2015/0223934	A1	8/2015	Vidlund et al.	DE	19532846	A1	3/1997
2015/0223935	A1	8/2015	Subramanian et al.	DE	19546692	A1	6/1997
2015/0238312	A1	8/2015	Lashinski	DE	19857887	A1	7/2000
2015/0238729	A1	8/2015	Jenson et al.	DE	19907646	A1	8/2000
2015/0272731	A1	10/2015	Racchini et al.	DE	10049812	A1	4/2002
2015/0305860	A1	10/2015	Wang et al.	DE	10049813	C1	4/2002
2015/0305864	A1	10/2015	Quadri et al.	DE	10049815	A1	4/2002
2015/0305868	A1	10/2015	Lutter et al.	DE	102006052564	B3	12/2007
2015/0327995	A1	11/2015	Morin et al.	DE	102006052710	A1	5/2008
2015/0328001	A1	11/2015	McLean	DE	102007043830	A1	4/2009
2015/0335424	A1	11/2015	McLean	DE	102007043831	A1	4/2009
2015/0335429	A1	11/2015	Morriss et al.	EP	0103546	A1	3/1984
2015/0342717	A1	12/2015	O'Donnell et al.	EP	1057460	A1	12/2000
2015/0351903	A1	12/2015	Morriss et al.	EP	1088529	A2	4/2001
2015/0351906	A1	12/2015	Hammer et al.	EP	1469797		10/2004
2016/0000562	A1	1/2016	Siegel	EP	1469797	B1	11/2005
2016/0008131	A1	1/2016	Christianson et al.	EP	2111800	A1	10/2009
2016/0067042	A1	3/2016	Murad et al.	EP	2193762	A1	6/2010
2016/0074160	A1	3/2016	Christianson et al.	EP	2278944	A2	2/2011
2016/0106537	A1	4/2016	Christianson et al.	EP	2747707	A1	7/2014
2016/0113764	A1	4/2016	Sheahan	EP	2918248	A1	9/2015
2016/0120673	A1	5/2016	Siegel et al.	FR	2788217	A1	7/2000
2016/0143736	A1	5/2016	Vidlund	FR	2815844	A1	5/2002
2016/0151155	A1	6/2016	Lutter et al.	FR	2815844	A1	5/2002
2016/0206280	A1	7/2016	Vidlund et al.	JP	2003505146	A	2/2003
2016/0242902	A1	8/2016	Morriss	JP	2005515836	A	6/2005
2016/0262879	A1	9/2016	Meiri et al.	JP	2009514628	A	4/2009
2016/0262881	A1	9/2016	Schankereli et al.	JP	2009519783	A	5/2009
2016/0278955	A1	9/2016	Liu et al.	JP	2010517623	A	5/2010
2016/0317290	A1	11/2016	Chau	JP	2013512765	A	4/2013
2016/0324635	A1	11/2016	Vidlund et al.	JP	2014532457	A	12/2014
2016/0331527	A1	11/2016	Vidlund et al.	NL	1017275	C2	8/2002
2016/0346086	A1	12/2016	Solem	SU	1271508	A1	11/1986
2016/0367365	A1	12/2016	Conklin	WO	9217118	A1	10/1992
2016/0367367	A1	12/2016	Maisano et al.	WO	9301768	A1	2/1993
2016/0367368	A1	12/2016	Vidlund et al.	WO	9829057		7/1998
2017/0071733	A1	3/2017	Ghione et al.	WO	9940964	A1	8/1999
2017/0079790	A1	3/2017	Vidlund et al.	WO	9947075	A1	9/1999
2017/0100245	A1	4/2017	Subramanian et al.	WO	2000018333	A1	4/2000
2017/0100248	A1	4/2017	Tegels et al.	WO	2000030550	A1	6/2000
2017/0128208	A1	5/2017	Christianson et al.	WO	2000041652		7/2000
2017/0181854	A1	6/2017	Christianson et al.	WO	2000047139	A1	8/2000
2017/0196688	A1	7/2017	Christianson et al.	WO	2001035878	A2	5/2001
2017/0252153	A1	9/2017	Chau et al.	WO	2001049213	A2	7/2001
2017/0266001	A1	9/2017	Vidlund et al.	WO	2001054624	A1	8/2001
2017/0281343	A1	10/2017	Christianson et al.	WO	2001054625	A1	8/2001
2017/0312076	A1	11/2017	Lutter et al.	WO	2001056512	A1	8/2001
				WO	2001061289	A1	8/2001
				WO	0176510	A2	10/2001

(56)

References Cited

FOREIGN PATENT DOCUMENTS

WO 2001076510 A2 10/2001
 WO 0182840 11/2001
 WO 2001082840 A1 11/2001
 WO 2002004757 A1 1/2002
 WO 0222054 A1 3/2002
 WO 2002022054 A1 3/2002
 WO 2002028321 A2 4/2002
 WO 0236048 A1 5/2002
 WO 2002036048 A1 5/2002
 WO 2002041789 A2 5/2002
 WO 0243620 A1 6/2002
 WO 0249540 A2 6/2002
 WO 2002043620 A1 6/2002
 WO 2002049540 A2 6/2002
 WO 2002076348 A1 10/2002
 WO 2003003943 A2 1/2003
 WO 2003030776 A2 4/2003
 WO 2003047468 A1 6/2003
 WO 2003049619 A2 6/2003
 WO 2004019825 A1 3/2004
 WO 2005102181 A1 11/2005
 WO 2006014233 A2 2/2006
 WO 2006034008 A2 3/2006
 WO 2006064490 A1 6/2006
 WO 2006070372 A2 7/2006
 WO 2006105009 A1 10/2006
 WO 2006113906 A1 10/2006
 WO 2006127756 A2 11/2006
 WO 2007081412 A1 7/2007
 WO 2007100408 A2 9/2007
 WO 2008005405 A2 1/2008
 WO 2008035337 A2 3/2008
 WO 2008091515 A2 7/2008
 WO 2008125906 A2 10/2008
 WO 2008147964 A1 12/2008
 WO 2009024859 A2 2/2009
 WO 2009026563 A2 2/2009
 WO 2009045338 A1 4/2009
 WO 2009132187 A1 10/2009
 WO 2010090878 A2 8/2010
 WO 2010098857 A1 9/2010
 WO 2010121076 A2 10/2010
 WO 2011017440 A2 2/2011
 WO 2011022658 A1 2/2011
 WO 2011069048 A2 6/2011
 WO 2011072084 A2 6/2011
 WO 201106735 A1 9/2011
 WO 2011109813 A2 9/2011
 WO 2011159342 A1 12/2011
 WO 2011163275 A2 12/2011
 WO 2012027487 A2 3/2012
 WO 2012036742 A2 3/2012
 WO 2012095116 A1 7/2012
 WO 2012177942 A2 12/2012
 WO 2013028387 A2 2/2013
 WO 2013045262 A1 4/2013
 WO 2013059747 A1 4/2013
 WO 2013028387 5/2013
 WO 2013096411 A1 6/2013
 WO 2013096757 A1 6/2013
 WO 2013116785 A1 8/2013
 WO 2013175468 A2 11/2013
 WO 2014121280 A2 8/2014
 WO 2014138284 A1 9/2014
 WO 2014144020 A1 9/2014
 WO 2014144937 A2 9/2014
 WO 2014162306 A2 10/2014
 WO 2014189974 A1 11/2014
 WO 2014194178 A1 12/2014
 WO 2014210124 A1 12/2014
 WO 2015051430 A1 4/2015
 WO 2015058039 A1 4/2015
 WO 2015063580 A2 5/2015
 WO 2015065646 A1 5/2015
 WO 2015120122 A2 8/2015

WO 2015138306 A2 9/2015
 WO 2015173609 A1 11/2015
 WO 2016112085 A2 7/2016
 WO 2016126942 A2 8/2016
 WO 2016168609 A1 10/2016
 WO 2016196933 A1 12/2016
 WO 2017096157 A1 6/2017
 WO 2017132008 A1 8/2017
 WO 2017218375 A1 12/2017
 WO 2018005779 A1 1/2018
 WO 2018013515 A1 1/2018

OTHER PUBLICATIONS

“Shape Memory Alloys,” Retrieved from the Internet: <<http://webdocs.cs.ualberta.ca/~about.database/MEMS/sma.html>>, Nov. 14, 2012, 3 pages.

Australian Search Report for Application No. AU 2016215197 dated Sep. 12, 2019.

Chinese Search Report for CN Application No. 201680013223.9, dated Oct. 29, 2018.

International Search Report and Written Opinion for International Application No. PCT/US2016/012305, dated Aug. 3, 2016, 18 pages.

US 9,155,620, 10/2015, Gross et al. (withdrawn).

“Shape Memory Alloys,” Retrieved from the Internet: <<http://webdocs.cs.ualberta.ca/~database/MEMS/sma.html>>, Feb. 5, 2016, 3 pages.

Al Zaibag, Muayed, et al., “Percutaneous Balloon Valvotomy in Tricuspid Stenosis,” *British Heart Journal*, Jan. 1987, vol. 57, No. 1, pp. 51-53.

Al-Khaja, N. et al., “Eleven Years’ Experience with Carpentier-Edwards Biological Valves in Relation to Survival and Complications,” *European Journal of Cardiothoracic Surgery*, Jun. 30, 1989, 3:305-311.

Almagor, Y. et al., “Balloon Expandable Stent Implantation in Stenotic Right Heart Valved Conduits,” *Journal of the American College of Cardiology*, Nov. 1, 1990, 16(6):1310-1314.

Andersen, H. R., “History of Percutaneous Aortic Valve Prosthesis,” *Herz*, Aug. 2009, 34(5):343-346.

Andersen, H. R., “Transluminal catheter implanted prosthetic heart valves,” *International Journal of Angiology*, 1998, 7(2):102-106.

Benchimol, A. et al., “Simultaneous Left Ventricular Echocardiography and Aortic Blood Velocity During Rapid Right Ventricular Pacing in Man,” *The American Journal of the Medical Sciences*, Jan.-Feb. 1977, 273(1):55-62.

Boudjemline, Y. et al., “Steps Toward the Percutaneous Replacement of Atrioventricular Valves: An Experimental Study,” *Journal of the American College of Cardiology*, Jul. 2005, 46(2):360-365.

Buckberg, G. et al., “Restoring Papillary Muscle Dimensions During Restoration in Dilated Hearts,” *Interactive Cardiovascular and Thoracic Surgery*, 2005, 4:475-477.

Chamberlain, G., “Ceramics Replace Body Parts,” *Design News*, Jun. 9, 1997, Issue 11, vol. 52, 5 pages.

Choo, S. J. et al., “Aortic Root Geometry: Pattern of Differences Between Leaflets and Sinuses of Valsava,” *The Journal of Heart Valve Disease*, Jul. 1999, 8:407-415.

Cullen, et al., “Transvenous, Antegrade Melody Valve-in-Valve Implantation for Bioprosthetic Mitral and Tricuspid Valve Dysfunction,” *JACC: Cardiovascular Interventions*, vol. 6, No. 6, Jun. 2013, pp. 598-605.

Declaration of Malcolm J. R. Dalrymple-Hay, Nov. 9, 2012, pp. 1-11; with Curriculum Vitae, Oct. 4, 2012.

Dotter, C. T. et al., “Transluminal Treatment of Arteriosclerotic Obstruction. Description of a New Technic and a Preliminary Report of its Application,” *Circulation*, Nov. 1964, 30:654-670.

Drawbaugh, K., “Feature—Heart Surgeons Explore Minimally Invasive Methods,” *Reuters Limited*, Jul. 16, 1996, 3 pages.

G. M. Bernacca, et al., “Polyurethane Heart Valves: Fatigue Failure, Calcification, and Polyurethane Structure,” *Journal of Biomedical Materials Research*, Mar. 5, 1997, Issue 3, vol. 34, pp. 371-379.

(56)

References Cited

OTHER PUBLICATIONS

- Gray, H., *The Aorta, Anatomy of the Human Body*, 1918, Retrieved from the Internet <<http://www.bartleby.com/107/142.html>>, Dec. 10, 2012, 5 pages.
- Gray, H., *The Heart, Anatomy of the Human Body*, 1918, Retrieved from the Internet <<http://education.yahoo.com/reference/gray/subjects/subject/138>>, Aug. 10, 2012, 9 pages.
- Greenhalgh, E. S., "Design and characterization of a biomimetic prosthetic aortic heart valve," 1994, ProQuest Dissertations and Theses, Department of Fiber and Polymer Science, North Carolina State University at Raleigh, 159 pages.
- H. R. Andersen et al., "Transluminal Implantation of Artificial Heart Valves: Description of a New Expandable Aortic Valve and Initial Results with Implantation by Catheter Technique in Closed Chest Pigs," *European Heart Journal*, 1992, Issue 5, vol. 13, pp. 704-708.
- Inoue, K. et al., "Clinical Application of Transvenous Mitral Commissurotomy by a New Balloon Catheter," *The Journal of Thoracic and Cardiovascular Surgery*, 1984, 87:394-402.
- International Search Report and Written Opinion for International Application No. PCT/US2016/016567, dated Aug. 3, 2016, 17 pages.
- Jin, X. Y. et al., "Aortic Root Geometry and Stentless Porcine Valve Competence," *Seminars in Thoracic and Cardiovascular Surgery*, Oct. 1999, 11(4):145-150.
- Knudsen, L. L. et al., "Catheter-implanted prosthetic heart valves. Transluminal catheter implantation of a new expandable artificial heart valve in the descending thoracic aorta in isolated vessels and closed chest pigs," *The International Journal of Artificial Organs*, 1993, 16(5):253-262.
- Kolata, G., "Device That Opens Clogged Arteries Gets a Failing Grade in a New Study," *New York Times* [online], <<http://www.nytimes.com/1991/01/03/health/device-that-opens-clogged-arteries-gets-a-failing-grade-in-a-new-study>>, published Jan. 3, 1991, retrieved from the Internet on Feb. 5, 2016, 3 pages.
- Lawrence, D. D., "Percutaneous Endovascular Graft: Experimental Evaluation," *Radiology*, 1987, 163:357-360.
- Lozonschi, L., et al., "Transapical mitral valved stent implantation: A survival series in swine," *The Journal of Thoracic and Cardiovascular Surgery*, 140(2):422-426 (Aug. 2010) published online Mar. 12, 2010, 1 page.
- Lutter, G. et al., "Mitral Valved Stent Implantation," *European Journal of Cardio-Thoracic Surgery*, 2010, 38:350-355, 2 pages.
- Ma, L. et al., "Double-crowned valved stents for off-pump mitral valve replacement," *European Journal of Cardio-Thoracic Surgery*, Aug. 2005, 28(2): 194-198.
- Moazami, N. et al., "Transluminal aortic valve placement: A feasibility study with a newly designed collapsible aortic valve," *ASAIO Journal*, Sep./ Oct. 1996, 42(5):M381-M385.
- Orton, C., "Mitral Seal: Hybrid Transcatheter Mitral Valve Replacement," *Symposium: Small Animal Proceedings*, 2011, pp. 311-312.
- Pavcnik, D. et al., "Development and Initial Experimental Evaluation of a Prosthetic Aortic Valve for Transcatheter Placement," *Radiology*, 1992; 183:151-154.
- Porstmann, W. et al., "Der Verschluss des Ductus Arteriosus Persistens ohne Thorakotomie," *Thoraxchirurgie Vasculare Chirurgie*, Band 15, Heft 2, Stuttgart, Apr. 1967, pp. 199-203.
- Rashkind, W. J., "Creation of an Atrial Septal Defect Without Thoracotomy," *The Journal of the American Medical Association*, Jun. 13, 1966, 196(11): 173-174.
- Rashkind, W. J., "Historical Aspects of Interventional Cardiology: Past, Present, Future," *Texas Heart Institute Journal*, Dec. 1986, 13(4):363-367.
- Reul, H. et al., "The Geometry of the Aortic Root in Health, at Valve Disease and After Valve Replacement," *J. Biomechanics*, 1990, 23(2):181-191.
- Robert C. Ashton Jr., "Development of an Intraluminal Device for the Treatment of Aortic Regurgitation: Prototype and in Vitro Testing System," *Journal of Thoracic and Cardiovascular Surgery*, 1996, Issue/vol. 112, pp. 979-983.
- Rosch, J. et al., "The Birth, Early Years and Future of Interventional Radiology," *J Vase Interv Radiol.*, Jul. 2003, 4:841-853.
- Ross, D. N., "Aortic Valve Surgery," *Guy's Hospital*, London, 1968, pp. 192-197.
- Rousseau, E. P. M. et al., "A Mechanical Analysis of the Closed Hancock Heart Valve Prosthesis," *Journal of Biomechanics*, 1998, 21(7):545-562.
- Sabbah, A. N. et al., "Mechanical Factors in the Degeneration of Porcine Bioprosthetic Valves: An Overview," Dec. 1989, *Journal of Cardiac Surgery*, 4(4):302-309.
- Selby, M.D., J. Bayne, "Experience with New Retrieval Forceps for Foreign Body Removal in the Vascular, Urinary, and Biliary Systems," *Radiology* 1990; 176:535-538.
- Serruys, P.W., et al., "Stenting of Coronary Arteries. Are we the Sorcerer's Apprentice?," *European Heart Journal* (1989) 10, 774-782, pp. 37-45, Jun. 13, 1989.
- Sigwart, U., "An Overview of Intravascular Stents: Old and New," Chapter 48, *Interventional Cardiology*, 2nd Edition, W.B. Saunders Company, Philadelphia, PA, © 1994, 1990, pp. 803-815.
- Tofeig, M. et al., "Transcatheter Closure of a Mid-Muscular Ventricular Septal Defect with an Amplatzer VSD Occluder Device," *Heart*, 1999, 81:438-440.
- Uchida, Barry T., et al., "Modifications of Gianturco Expandable Wire Stents," *AJR*:150, May 1988, Dec. 3, 1987, pp. 1185-1187.
- Watt, A.H., et al., "Intravenous Adenosine in the Treatment of Supraventricular Tachycardia; a Dose-Ranging Study and Interaction with Dipyridamole," *British Journal of Clinical Pharmacology* (1986), 21, pp. 227-230.
- Webb, J. G. et al., "Percutaneous Aortic Valve Implantation Retrograde from the Femoral Artery," *Circulation*, 2006, 113:842-850.
- Wheatley, M.D., David J., "Valve Prostheses," *Rob & Smith's Operative Surgery*, Fourth Edition, pp. 415-424, Butterworths 1986.
- Yoganathan, A. P. et al., "The Current Status of Prosthetic Heart Valves," In *Polymetric Materials and Artificial Organs*, Mar. 20, 1983, pp. 111-150, American Chemical Society.
- A. P. Yoganathan et al., "The Current Status of Prosthetic Heart Valves, Polymetric Materials and Artificial Organs," *American Chemical Society*, Mar. 20, 1983 pp. 111-150.
- Al Zaibag, M. et al., "Percutaneous Balloon Valvotomy in Tricuspid Stenosis," *British Heart Journal*, Jan. 1987, 57(1):51-53.
- Bernacca, G. M. et al., "Polyurethane heart valves: Fatigue failure, calcification, and polyurethane structure," *Journal of Biomedical Materials Research*, Mar. 5, 1997, 34(3):371-379.
- Henning Rud Andersen, "Transluminal Catheter Implanted Prosthetic Heart Valves," *International Journal of Angiology*, 1998, Issue 2, vol. 7 pp. 102-106.
- Lutter, Georg, et al., "Mitral Valved Stent Implantation," *European Journal of Cardio-Thoracic Surgery*, 2010, vol. 38pp. 350-355.
- Rousseau, E. P. M. et al., "A mechanical analysis of the closed Hancock heart valve prosthesis," *Journal of Biomechanics*, 1988, 21(7):545-562.
- International Search Report for Appl. No. PCT/US2021/040996 dated Oct. 21, 2021. (3 pages).

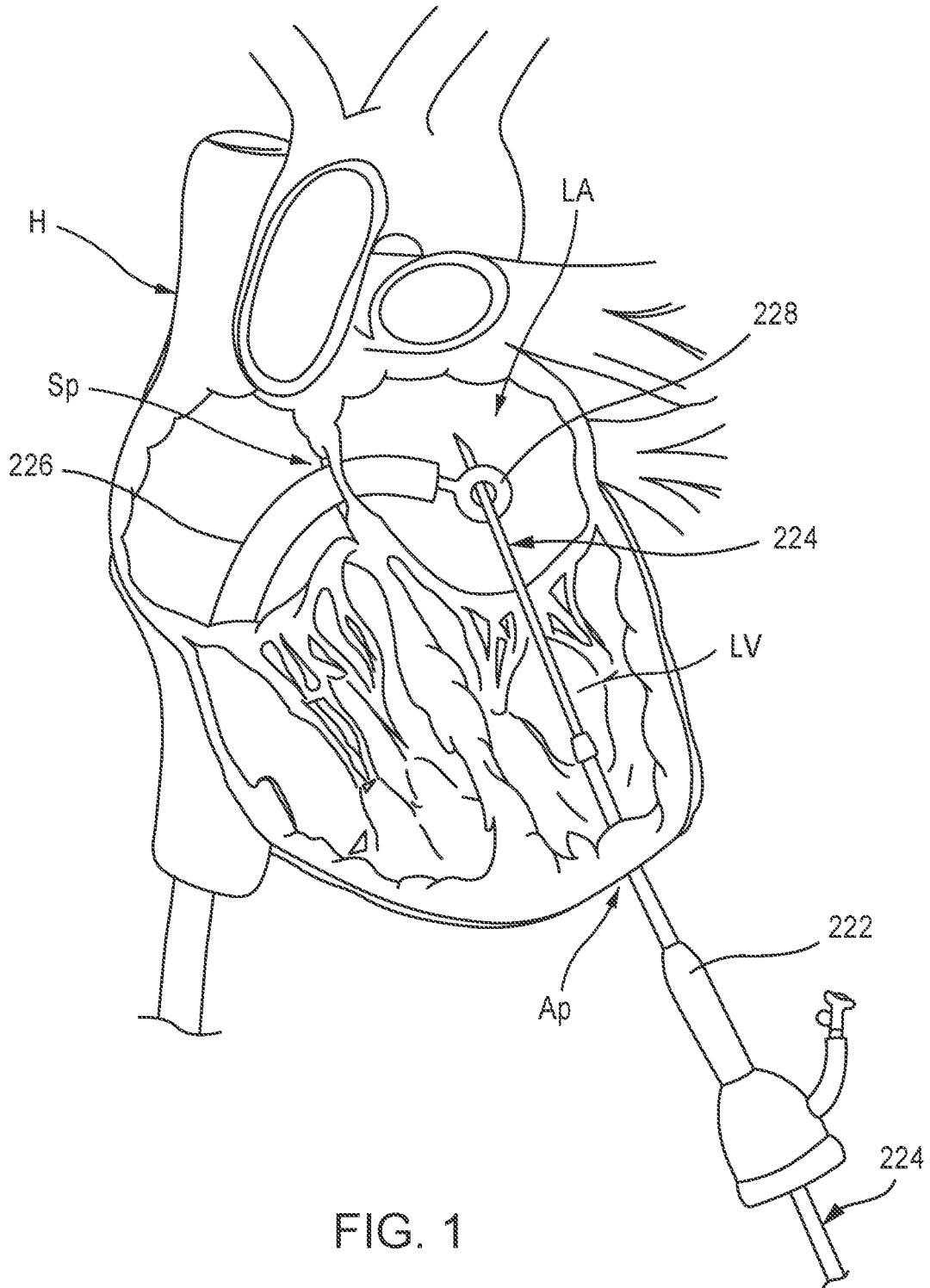

FIG. 1

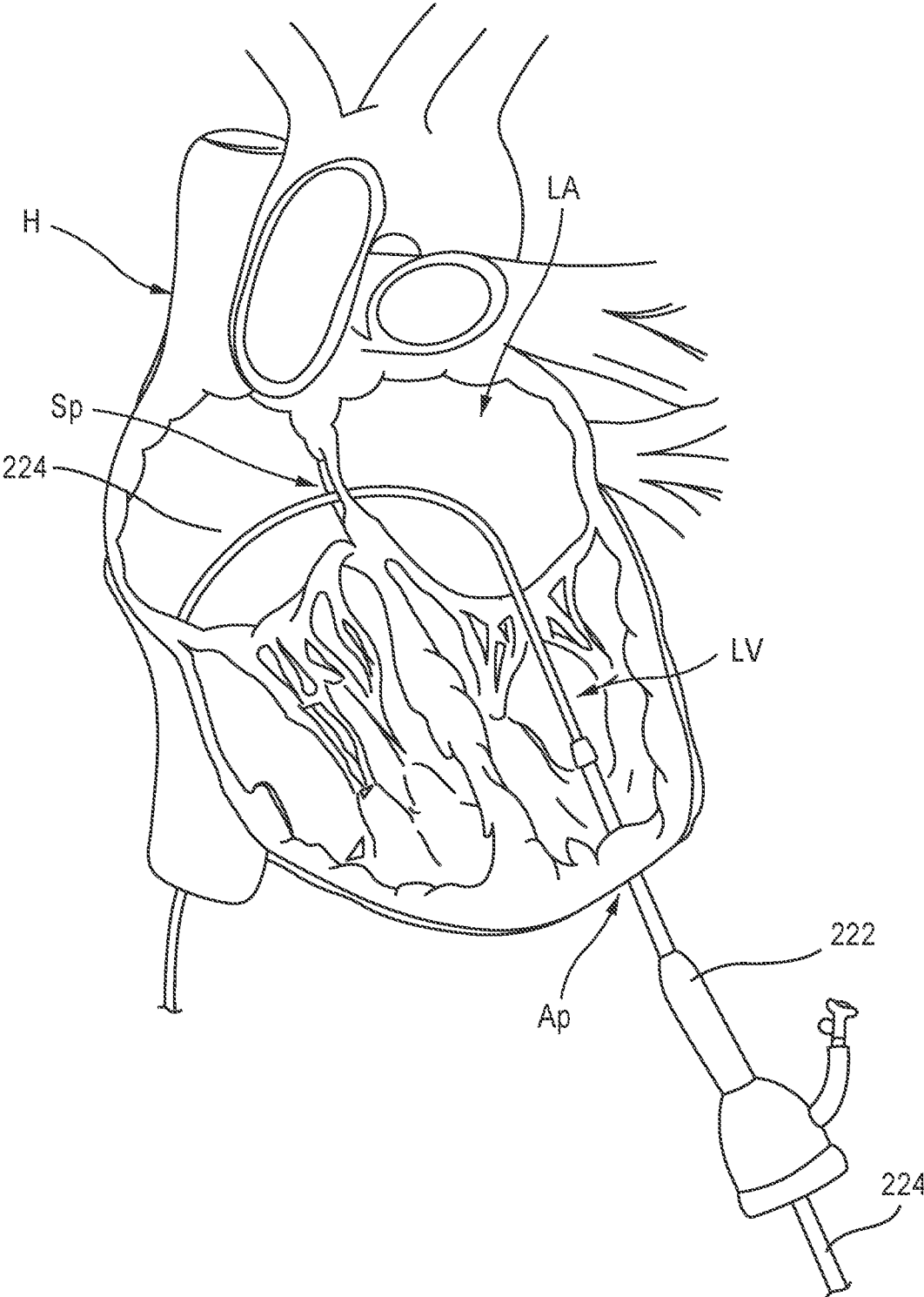

FIG. 2

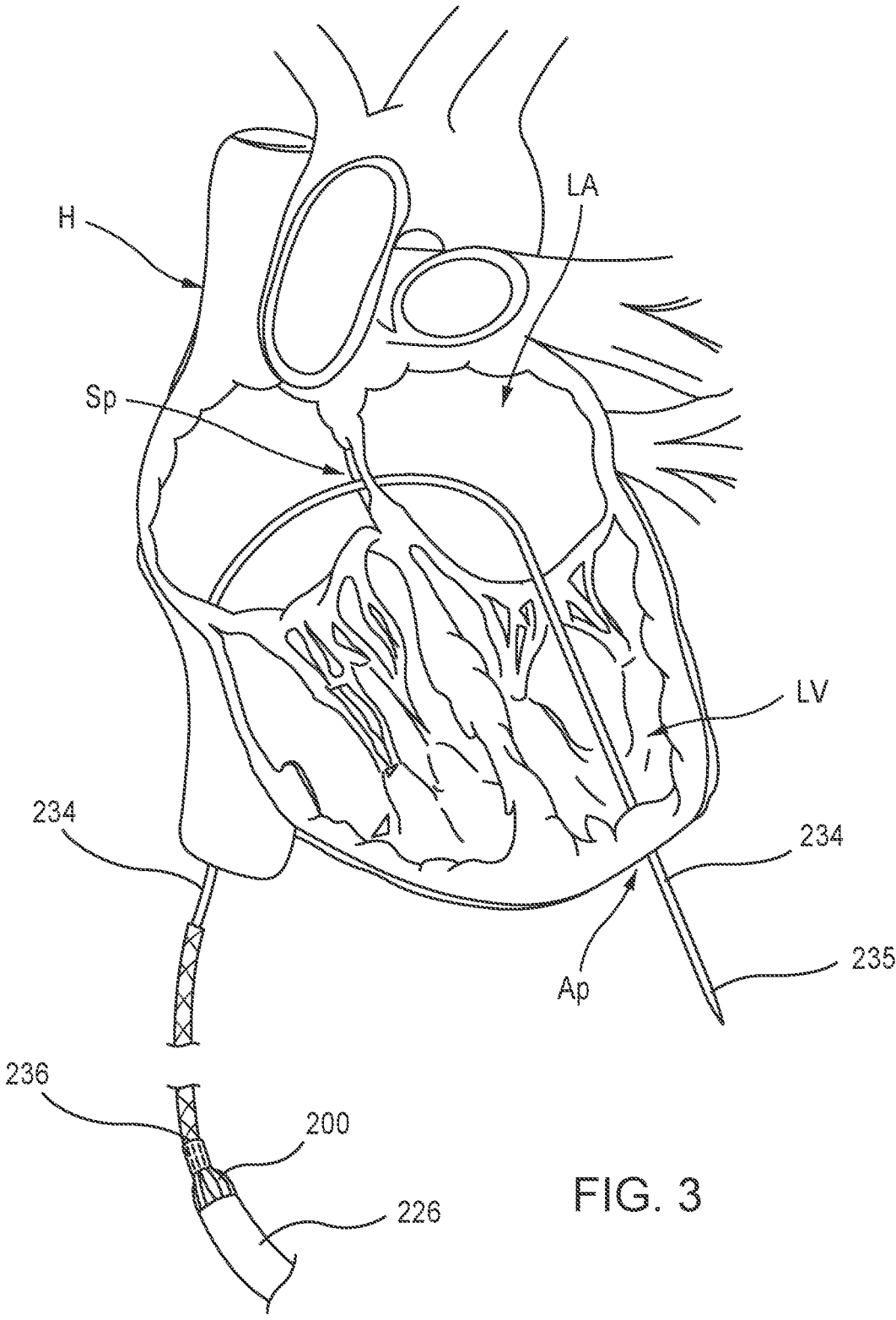

FIG. 3

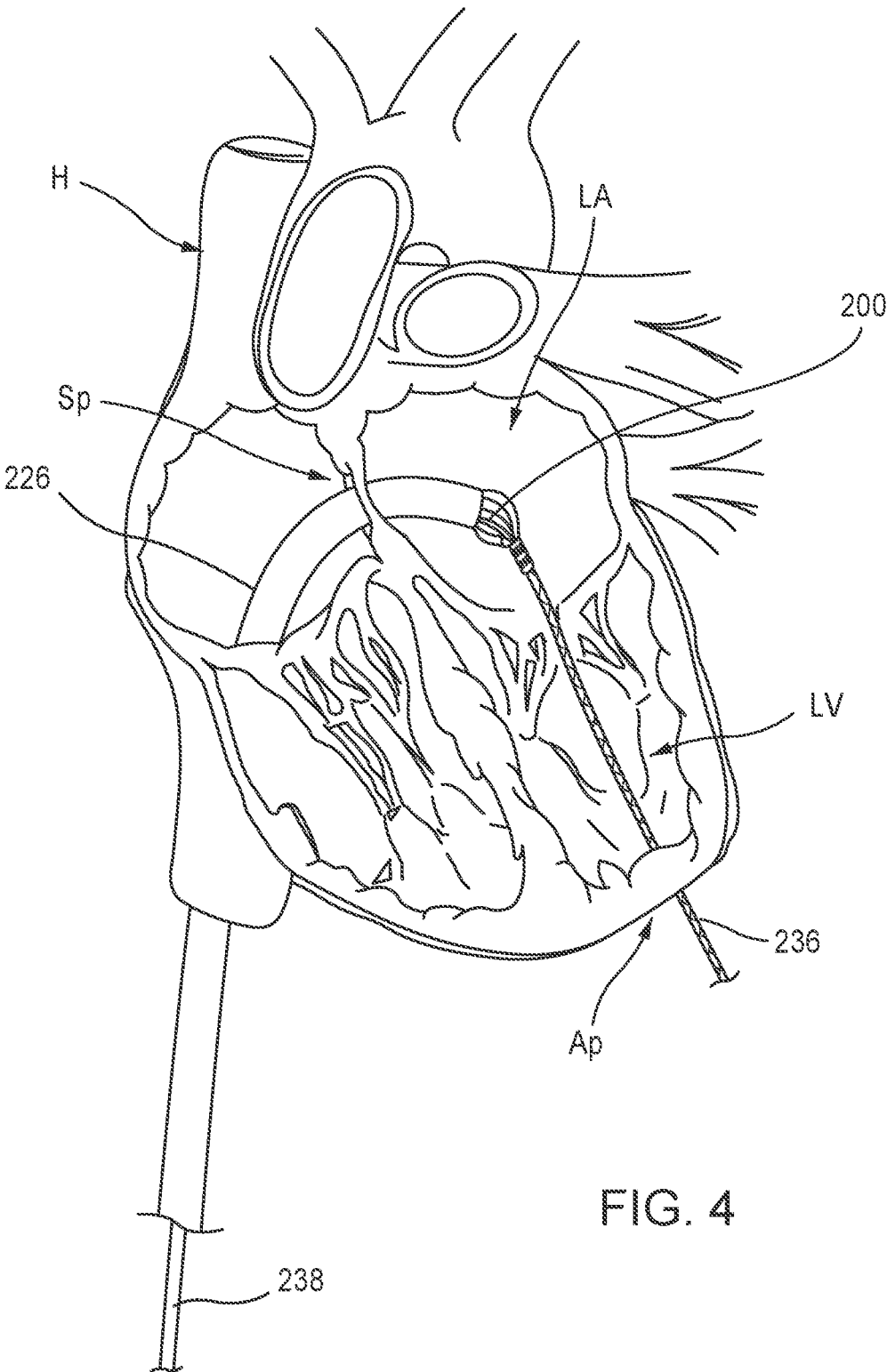

FIG. 4

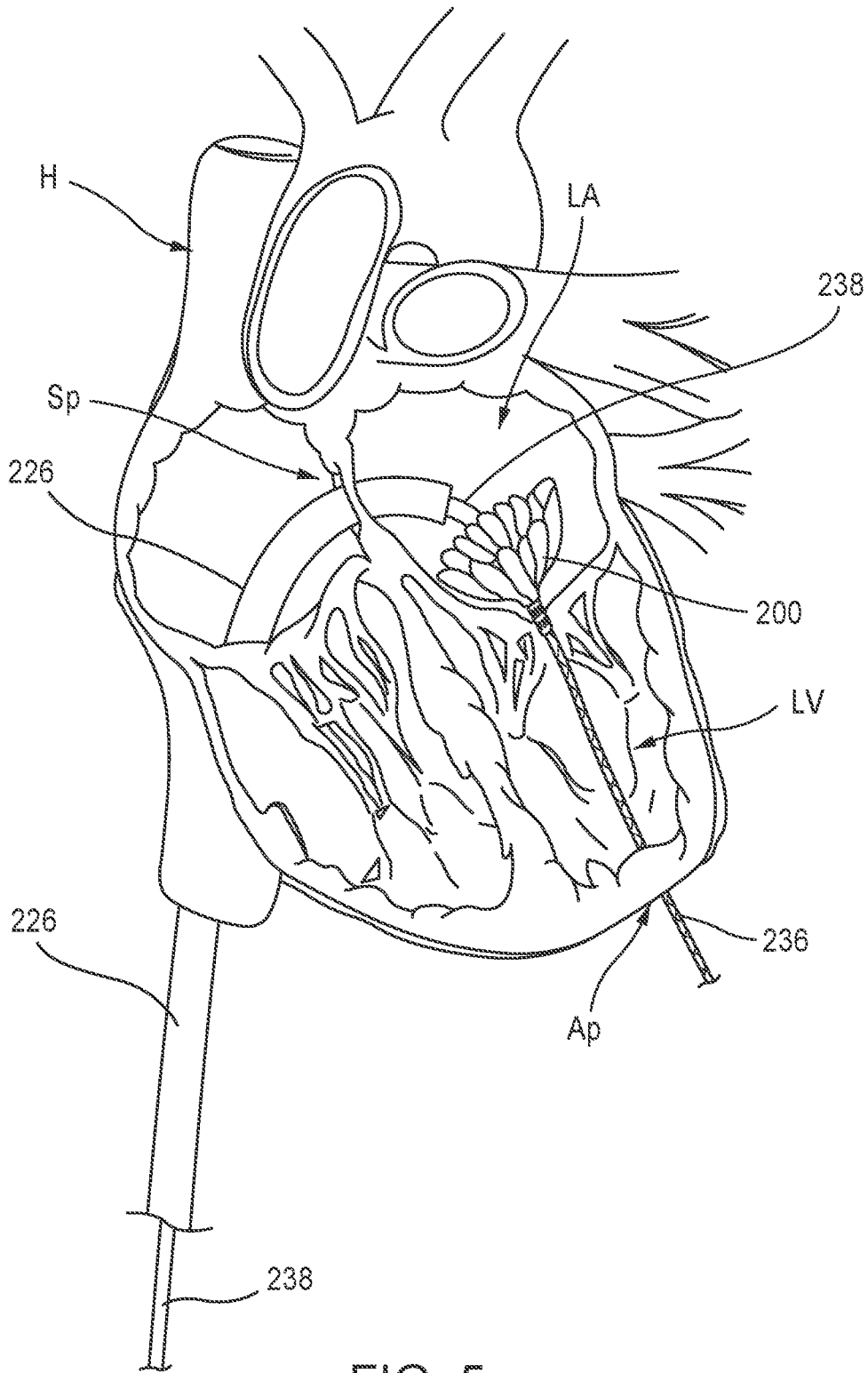

FIG. 5

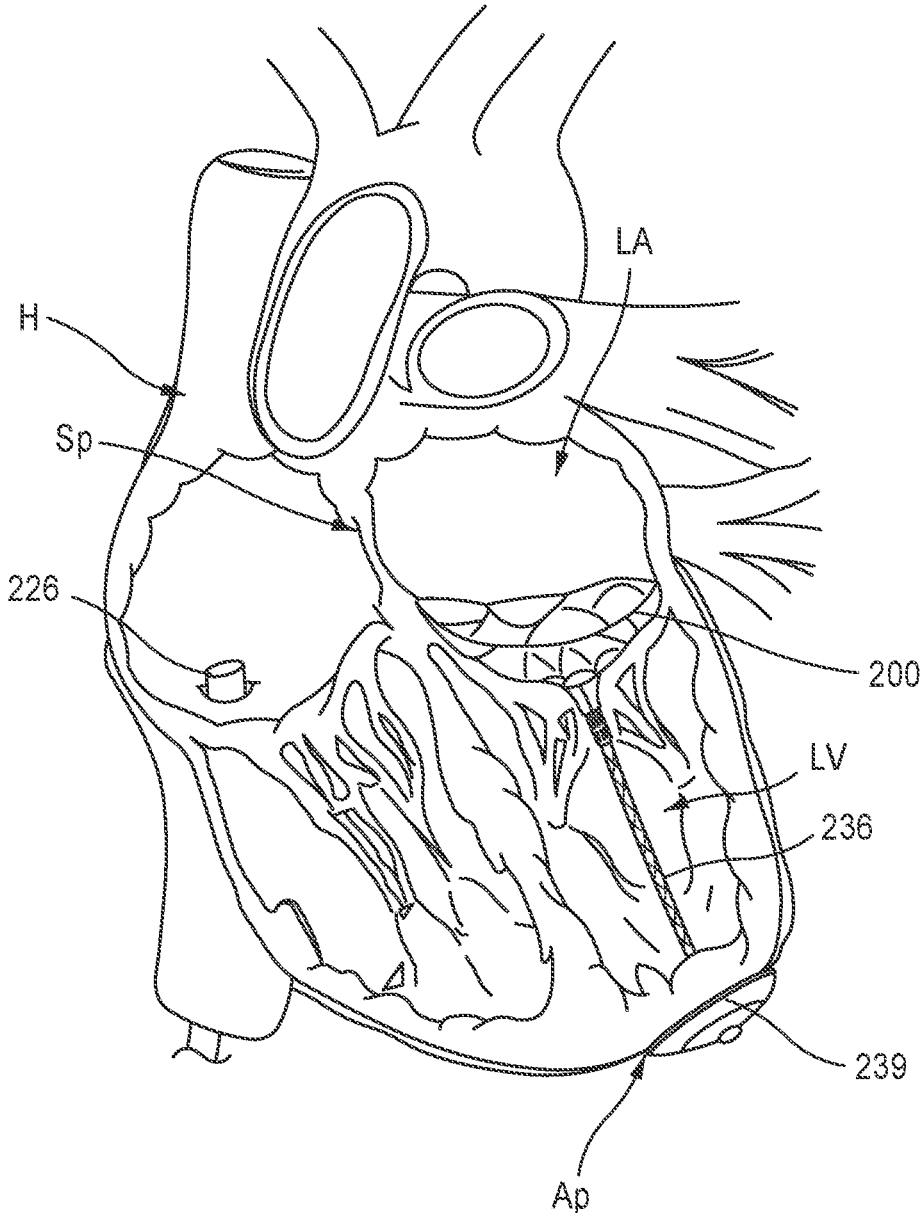

FIG. 6

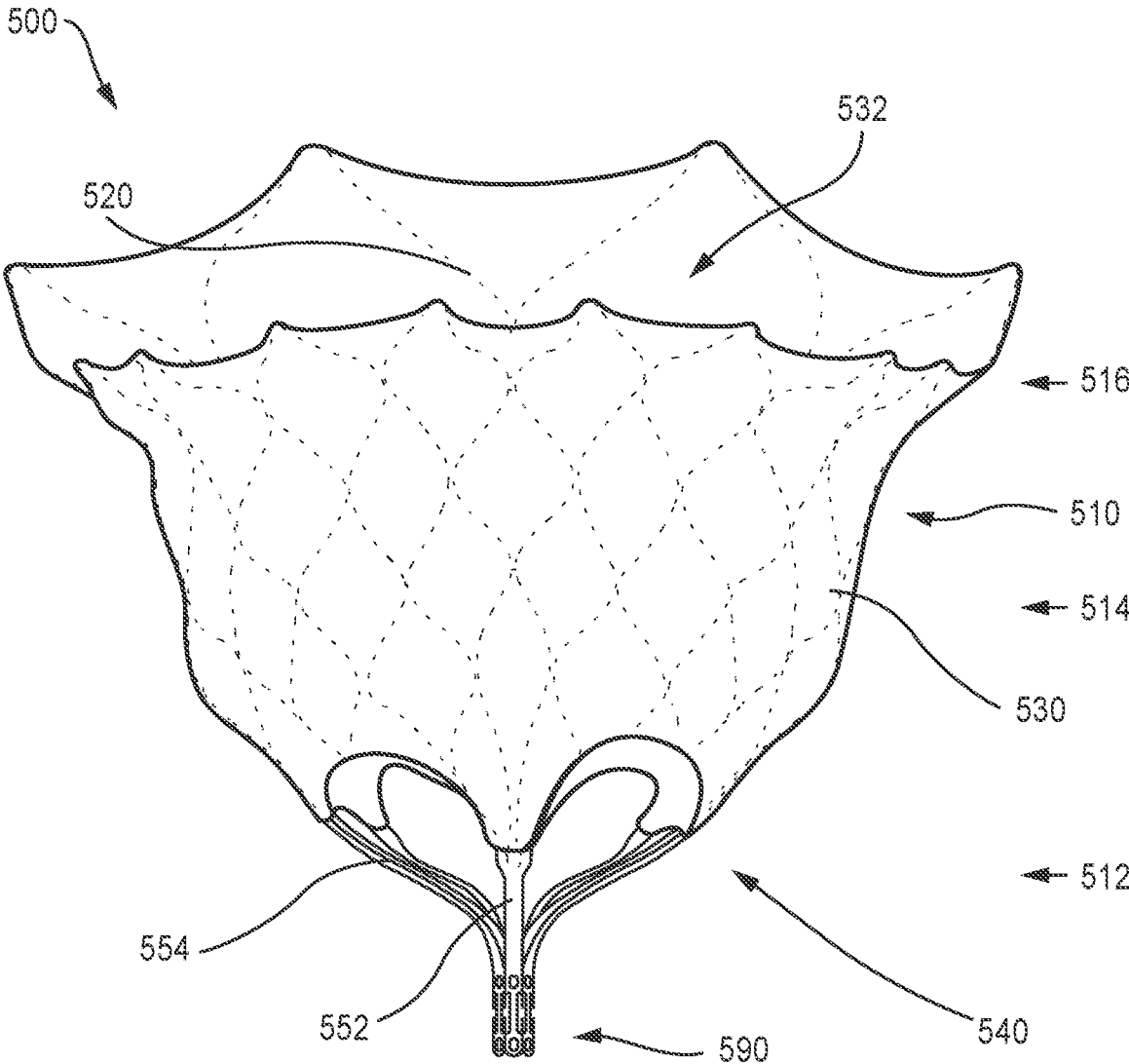

FIG. 7

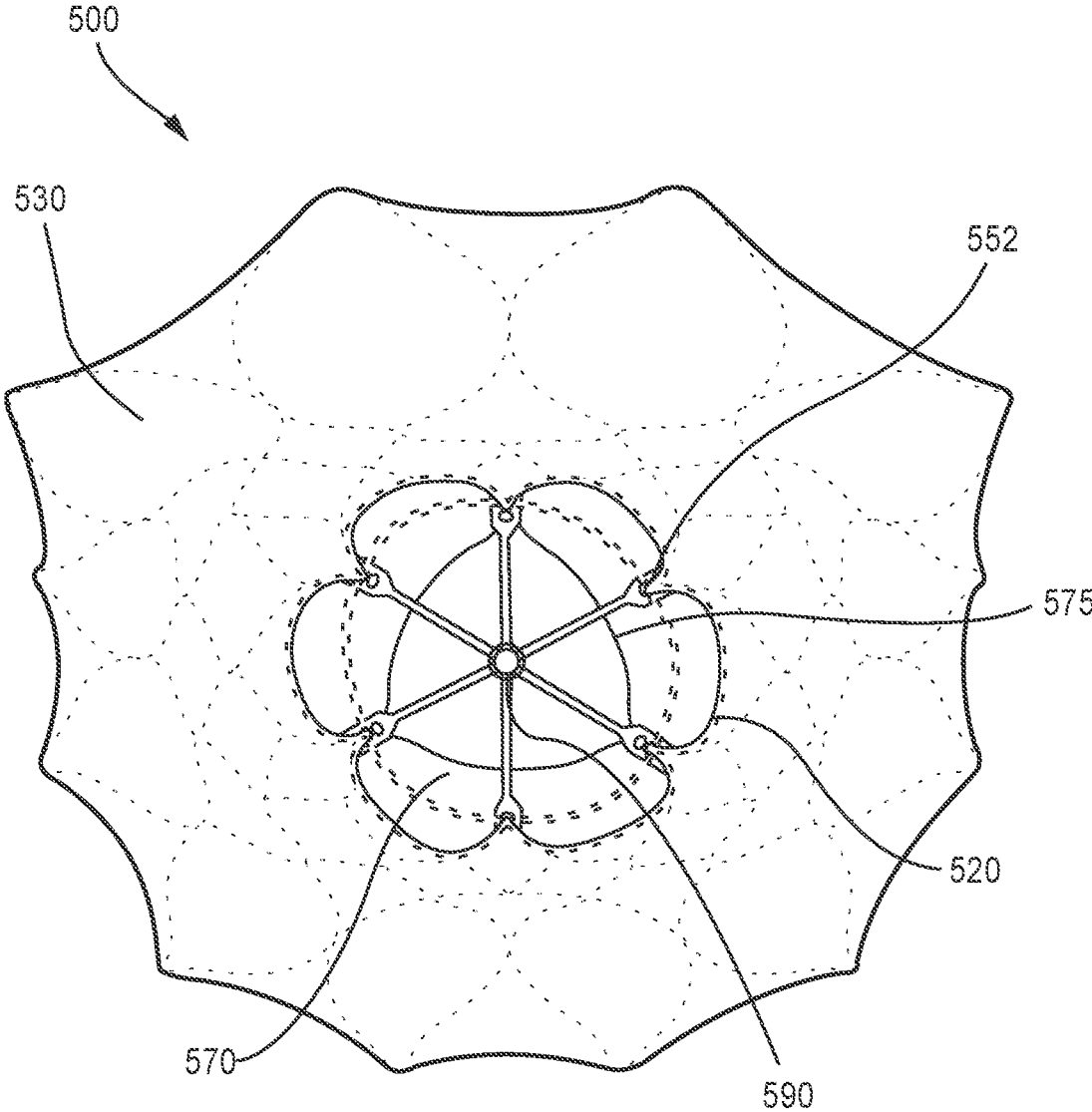

FIG. 8

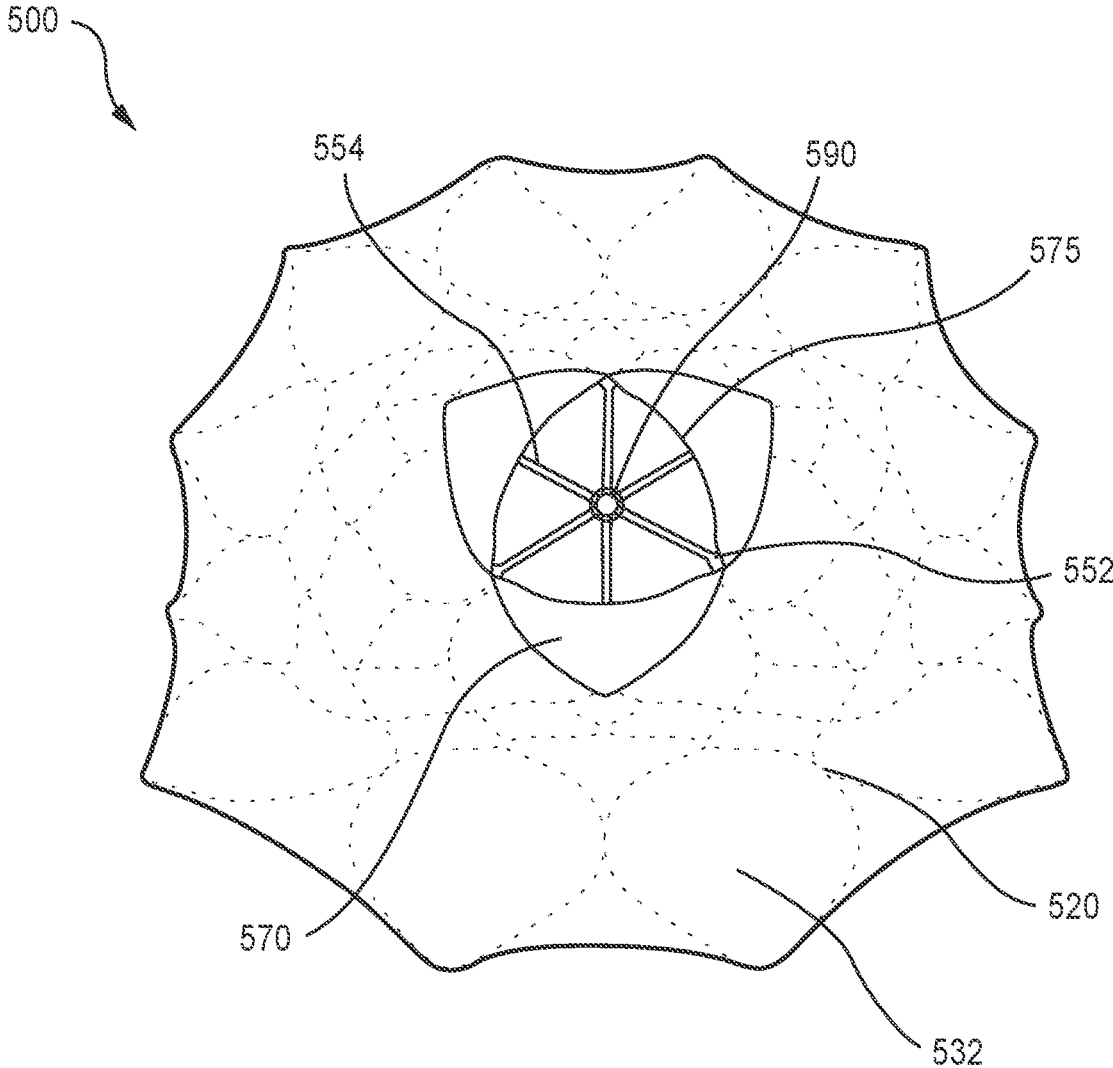

FIG. 9

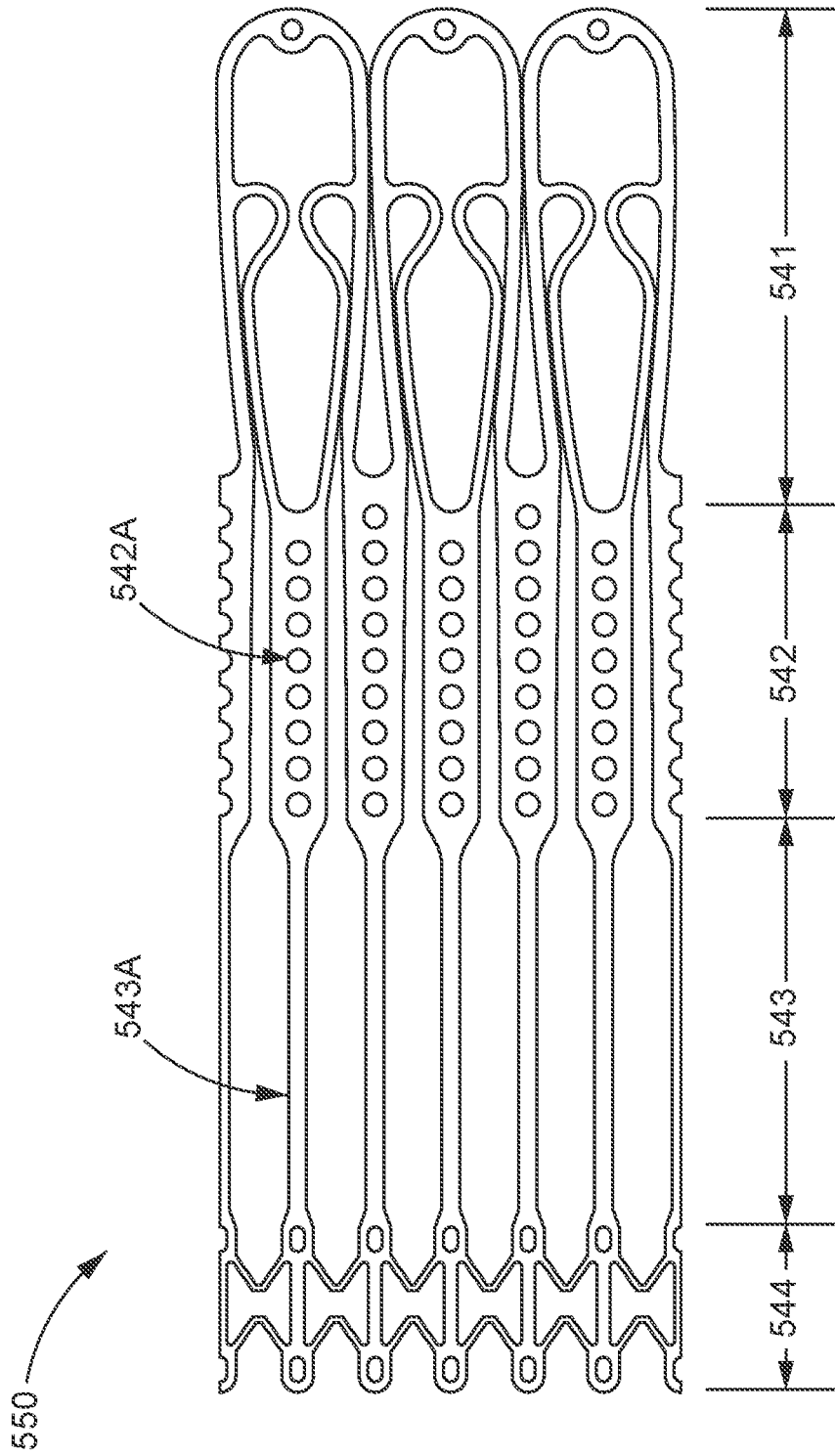

FIG. 10

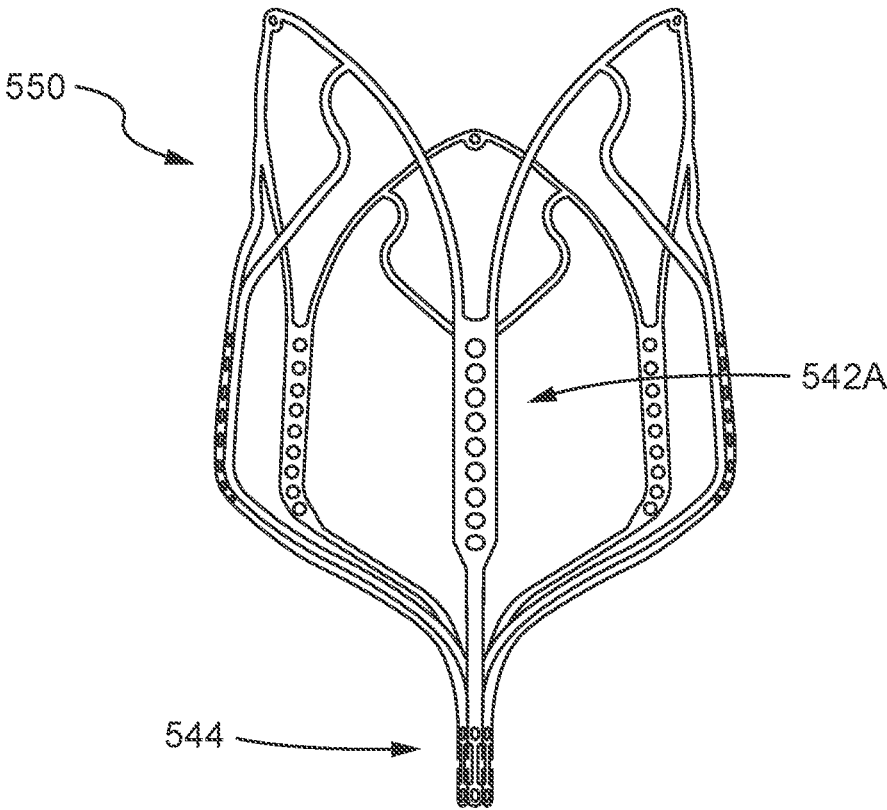

FIG. 11

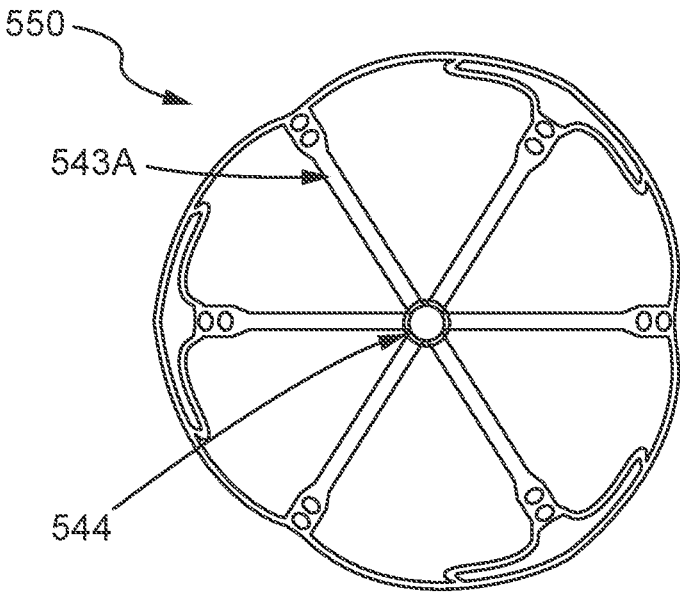

FIG. 12

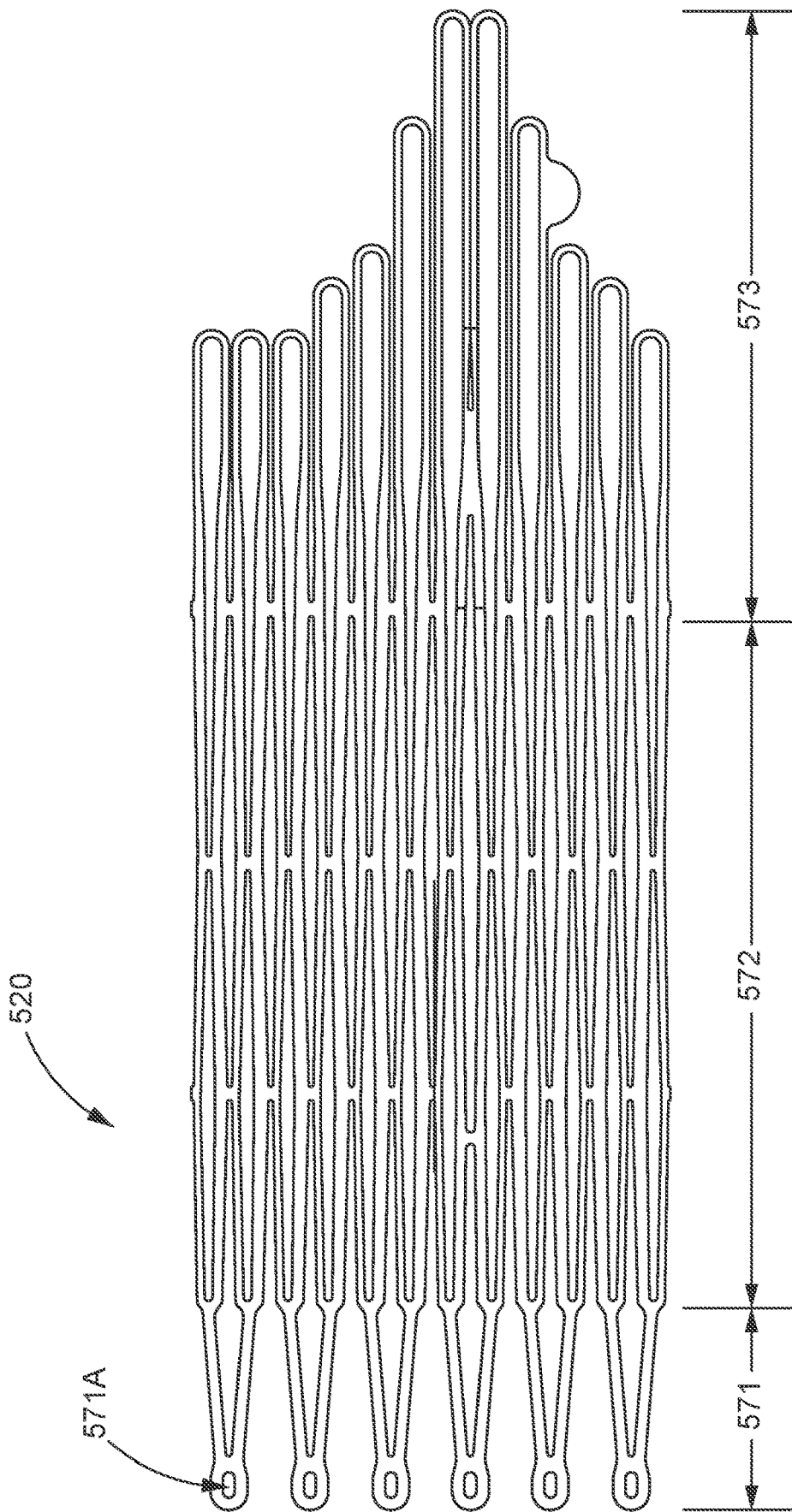

FIG. 13

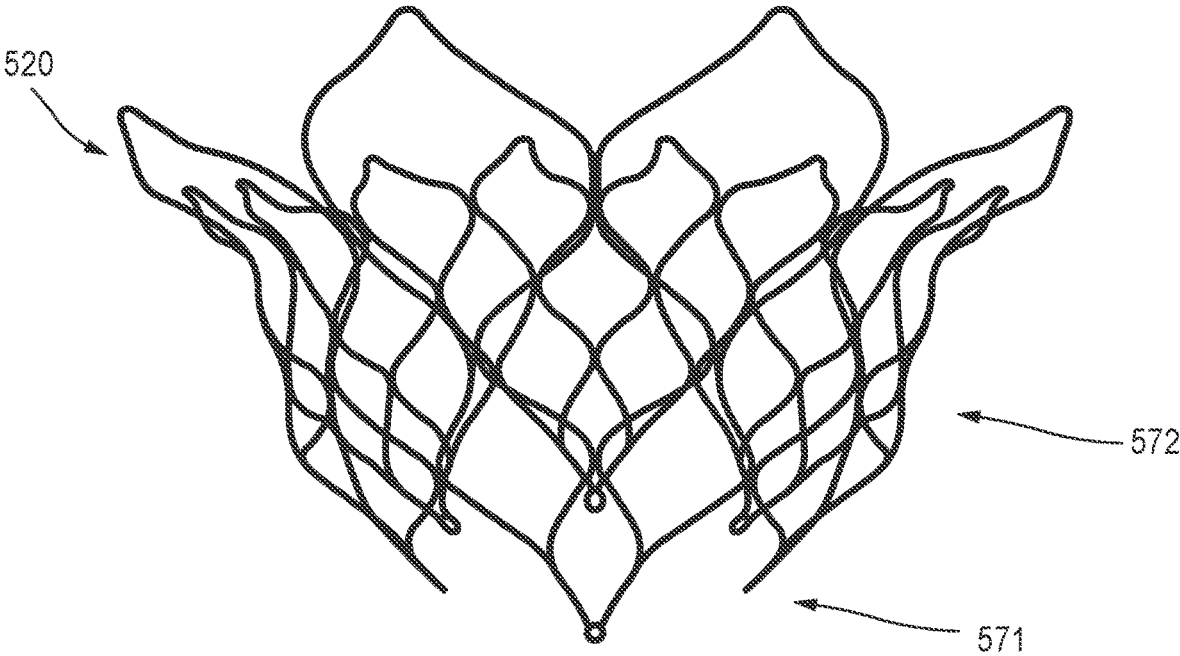

FIG. 14

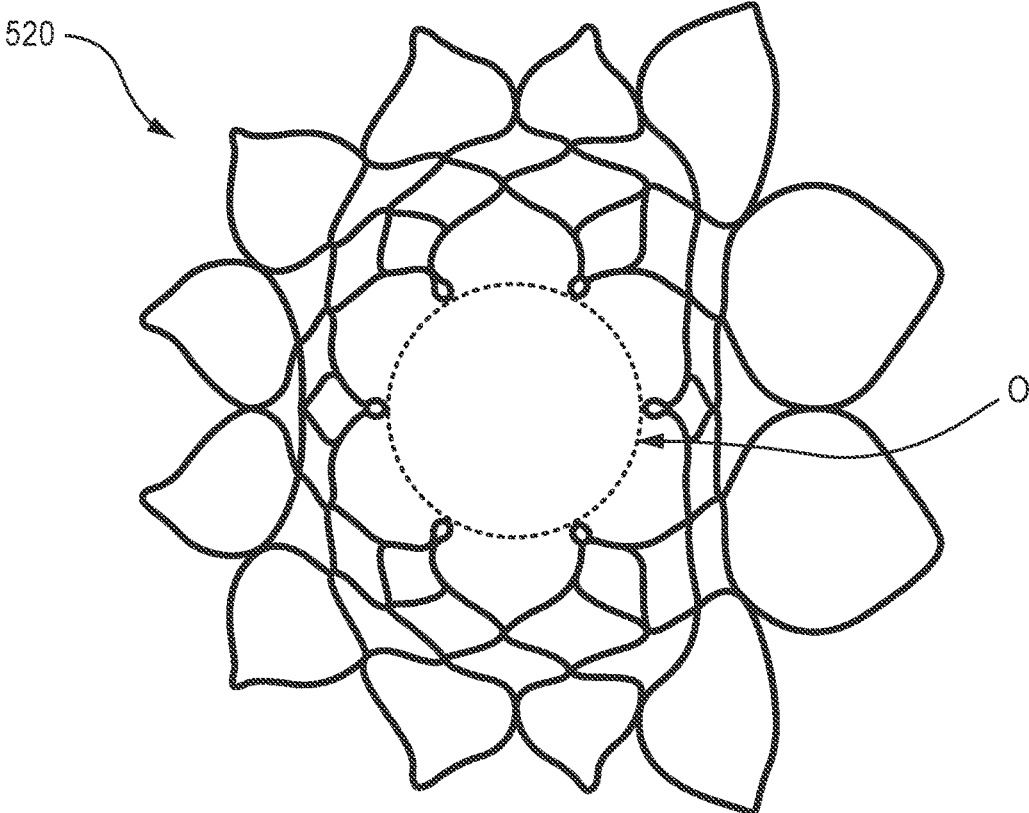

FIG. 15

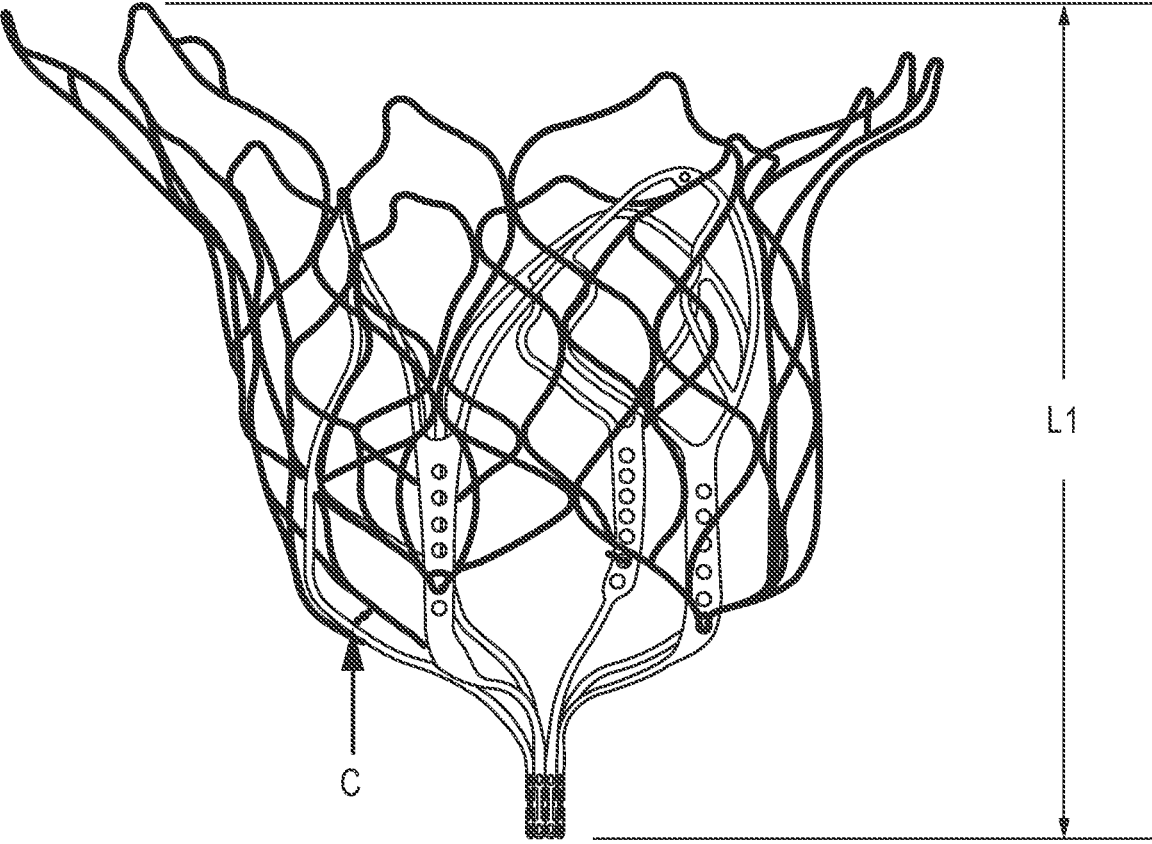

FIG. 16

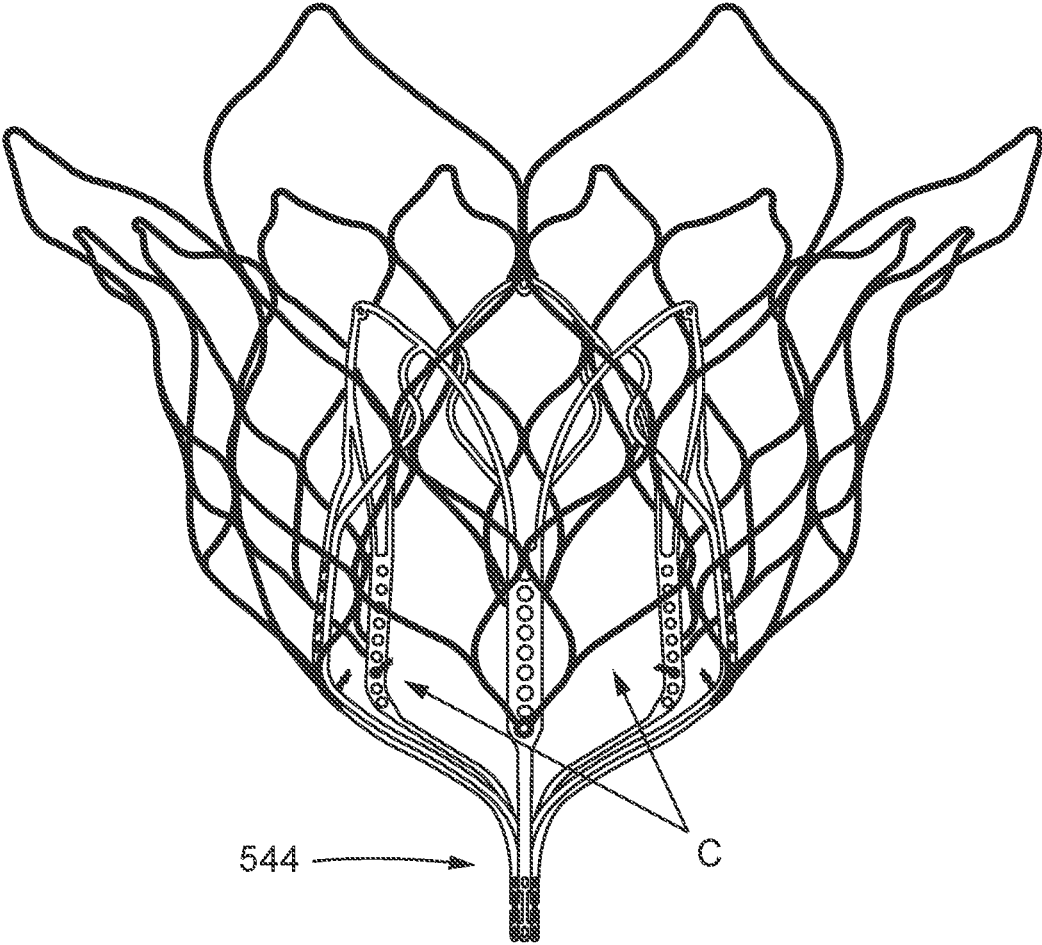

FIG. 17

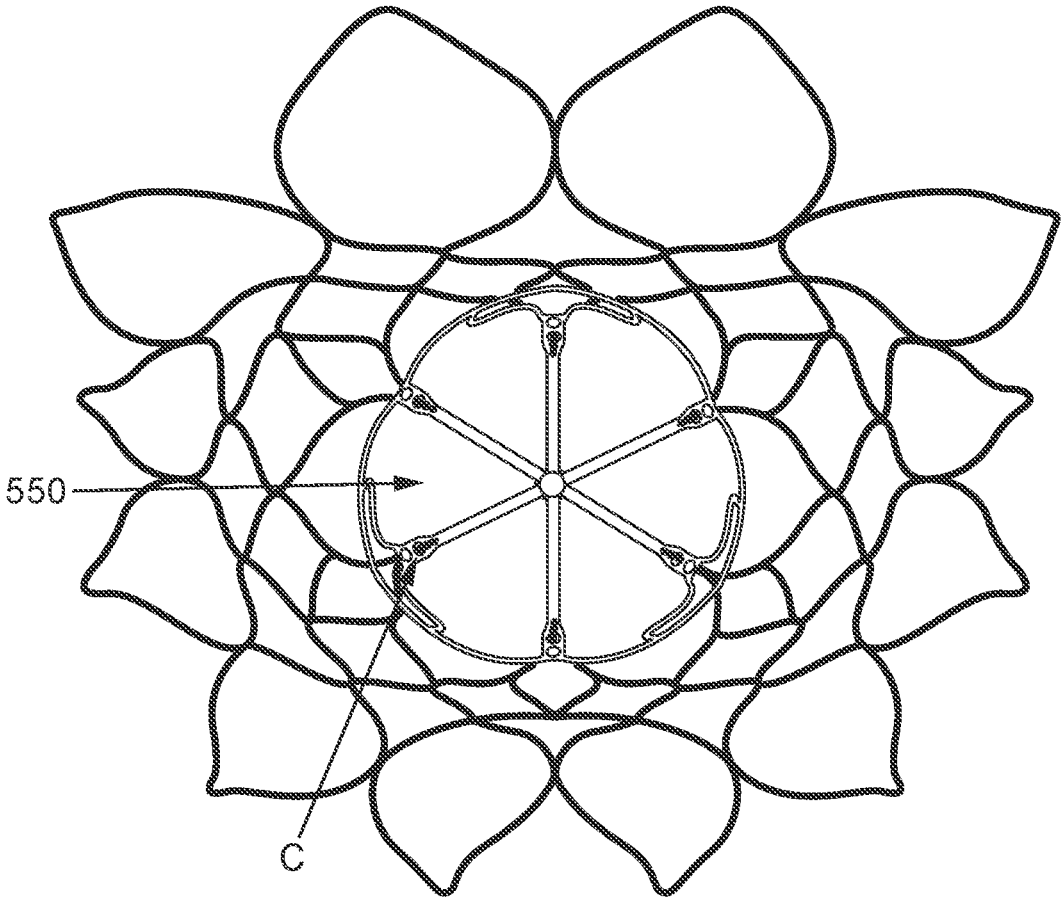

FIG. 18

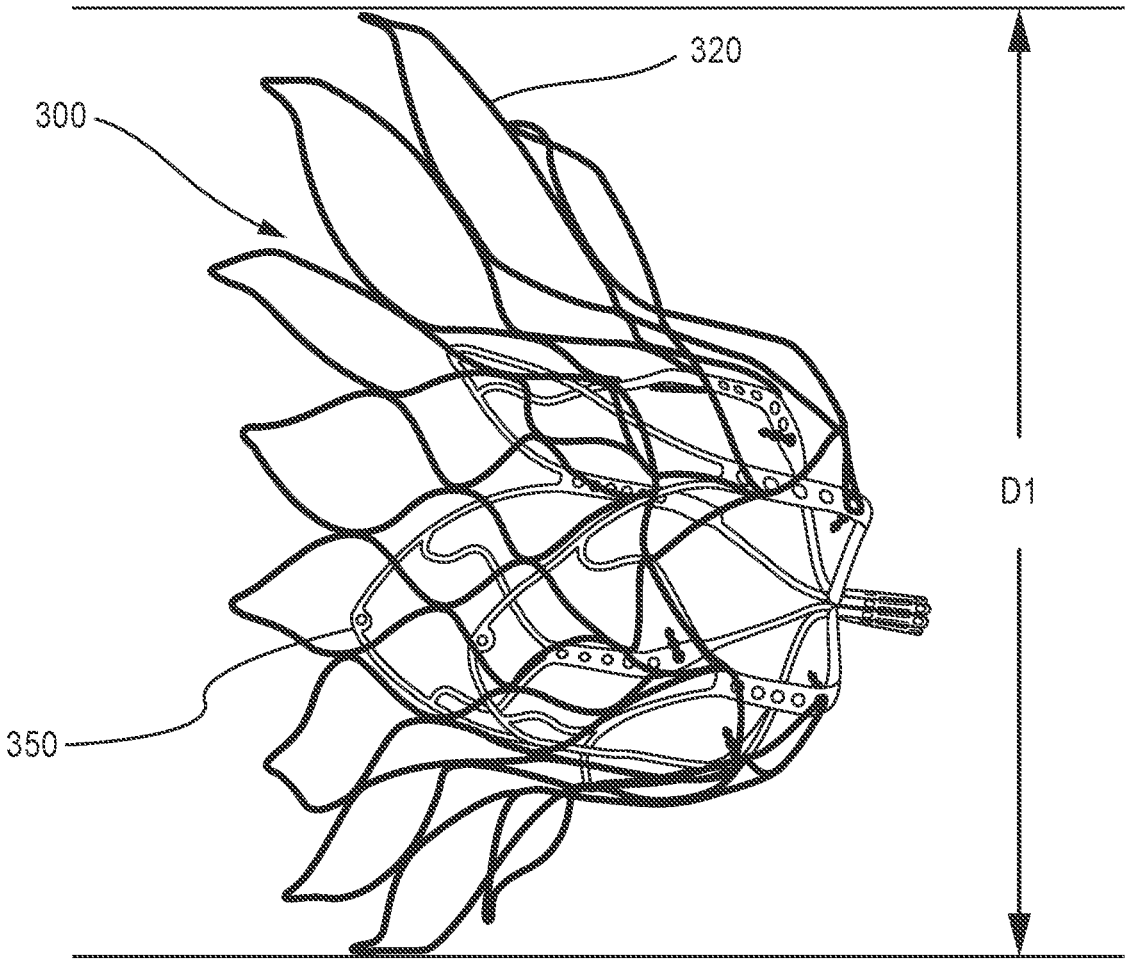

FIG. 19

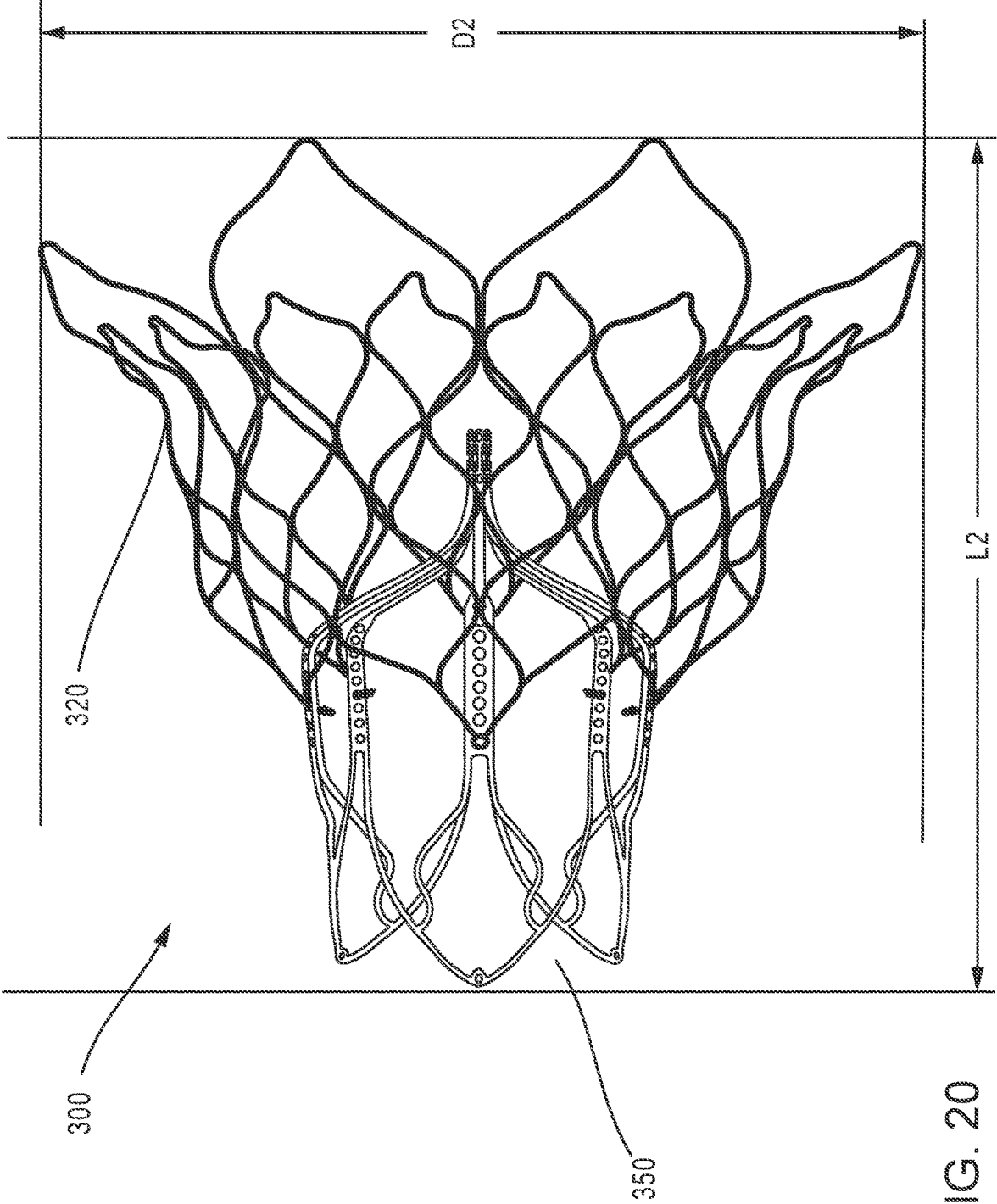

FIG. 20

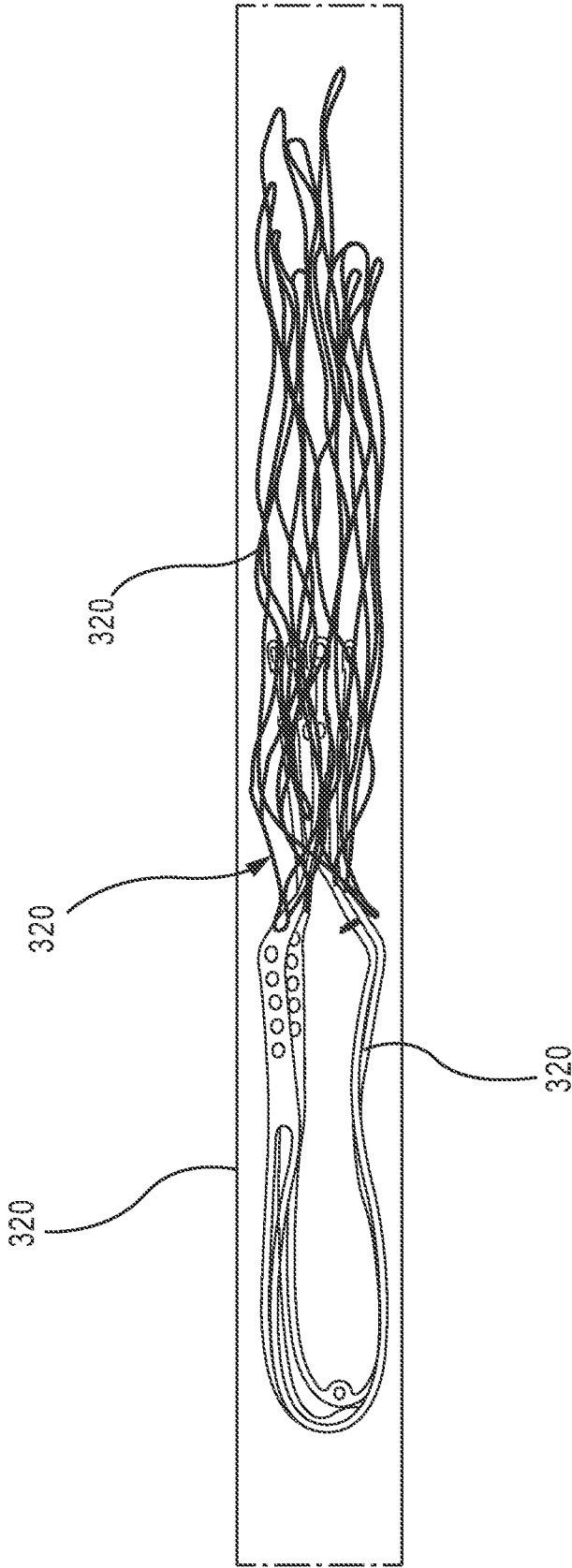

FIG. 21

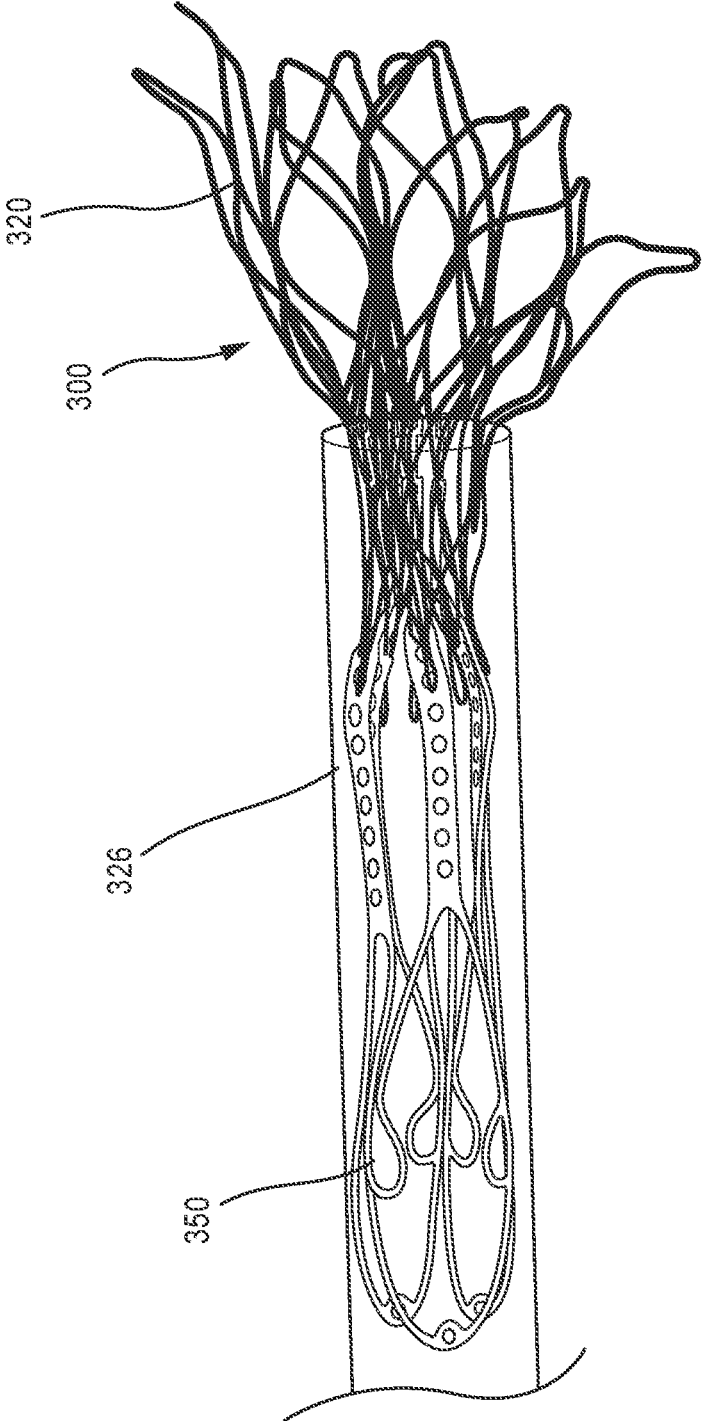

FIG. 22

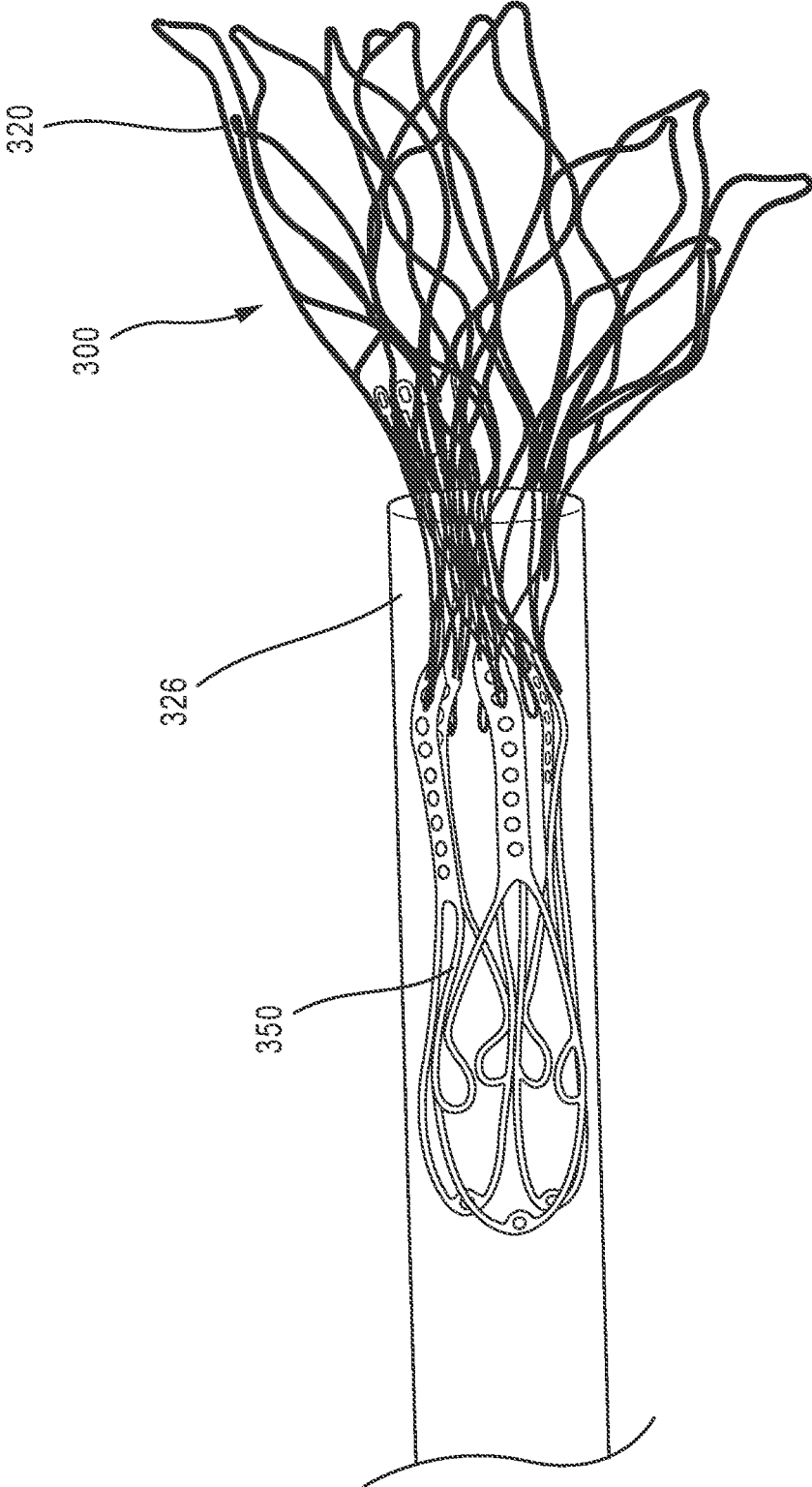

FIG. 23

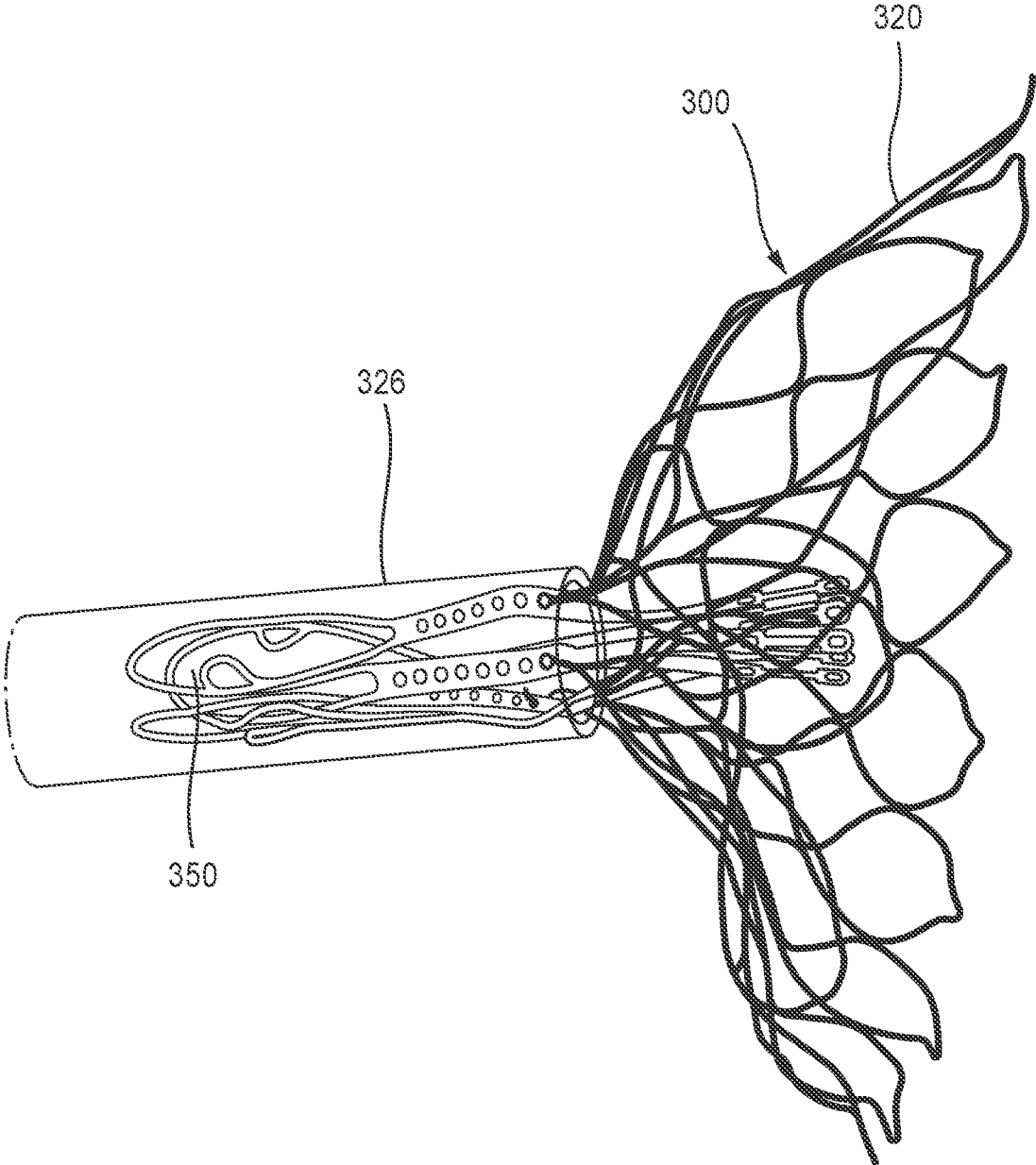

FIG. 24

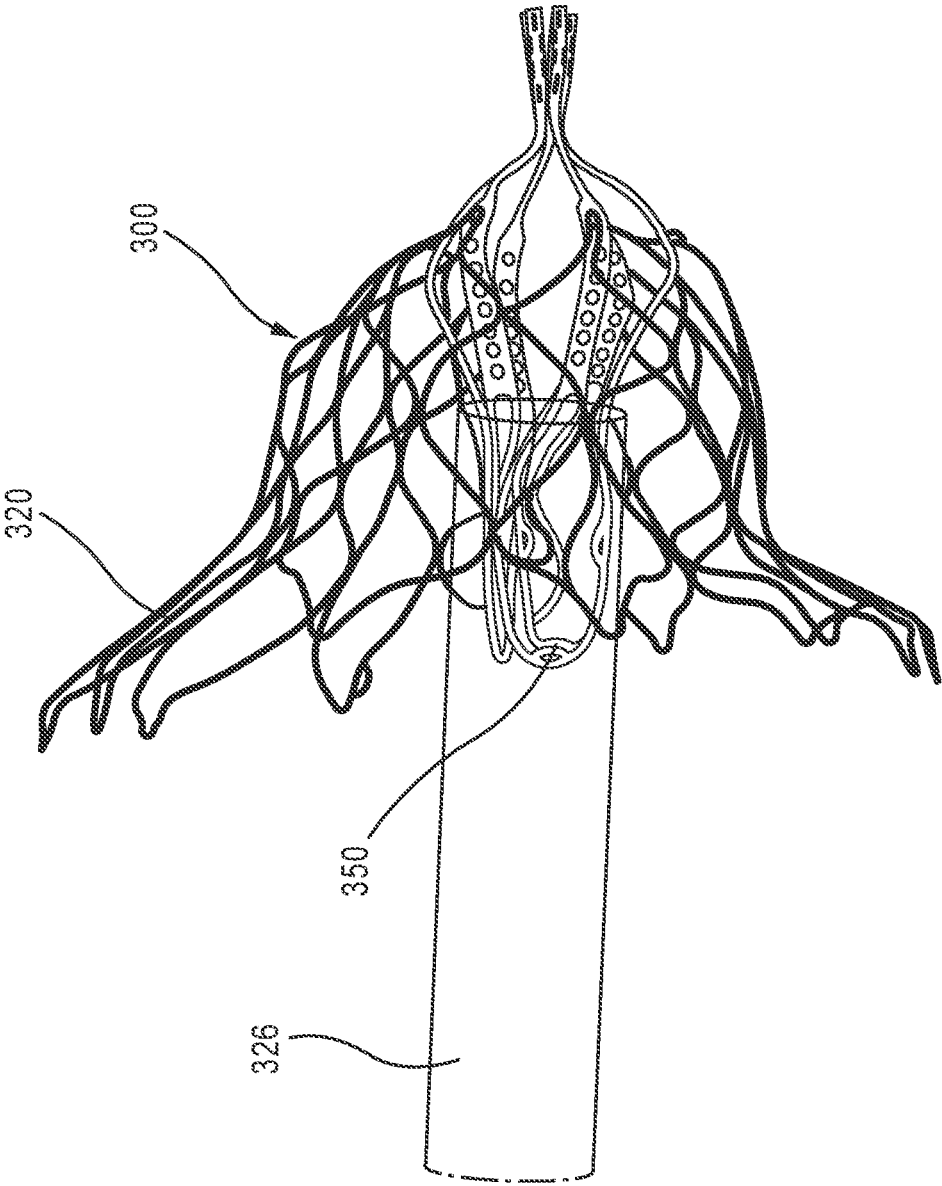

FIG. 25

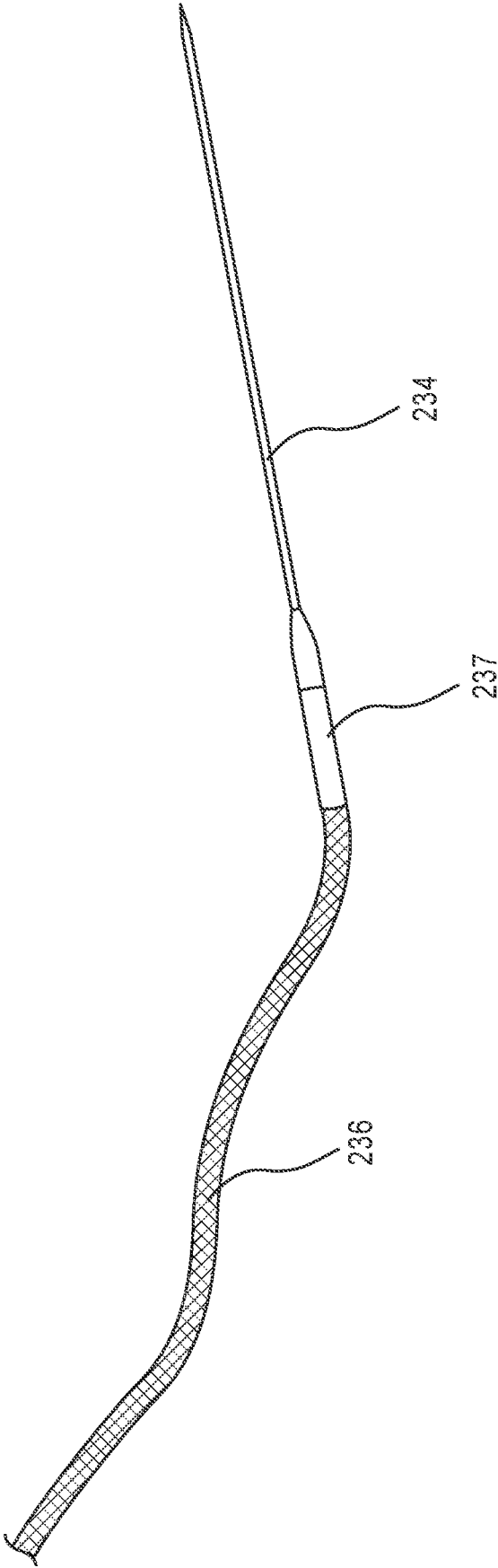

FIG. 26

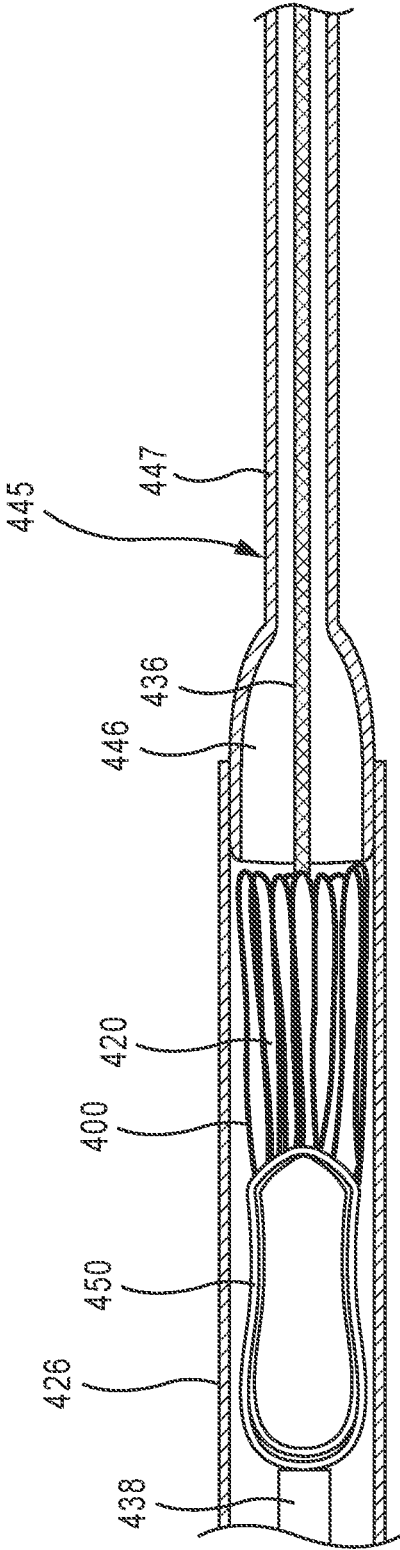
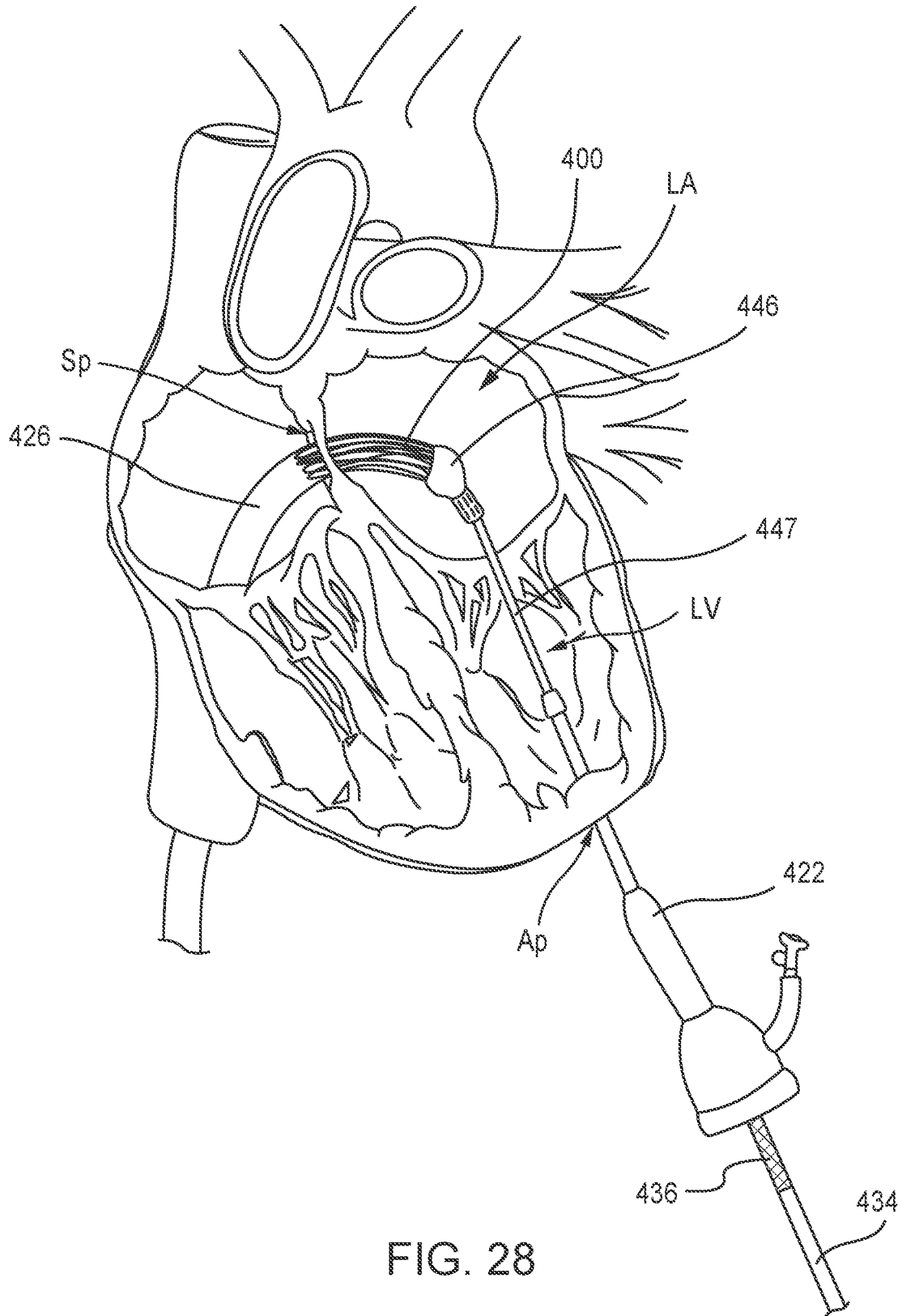

FIG. 27



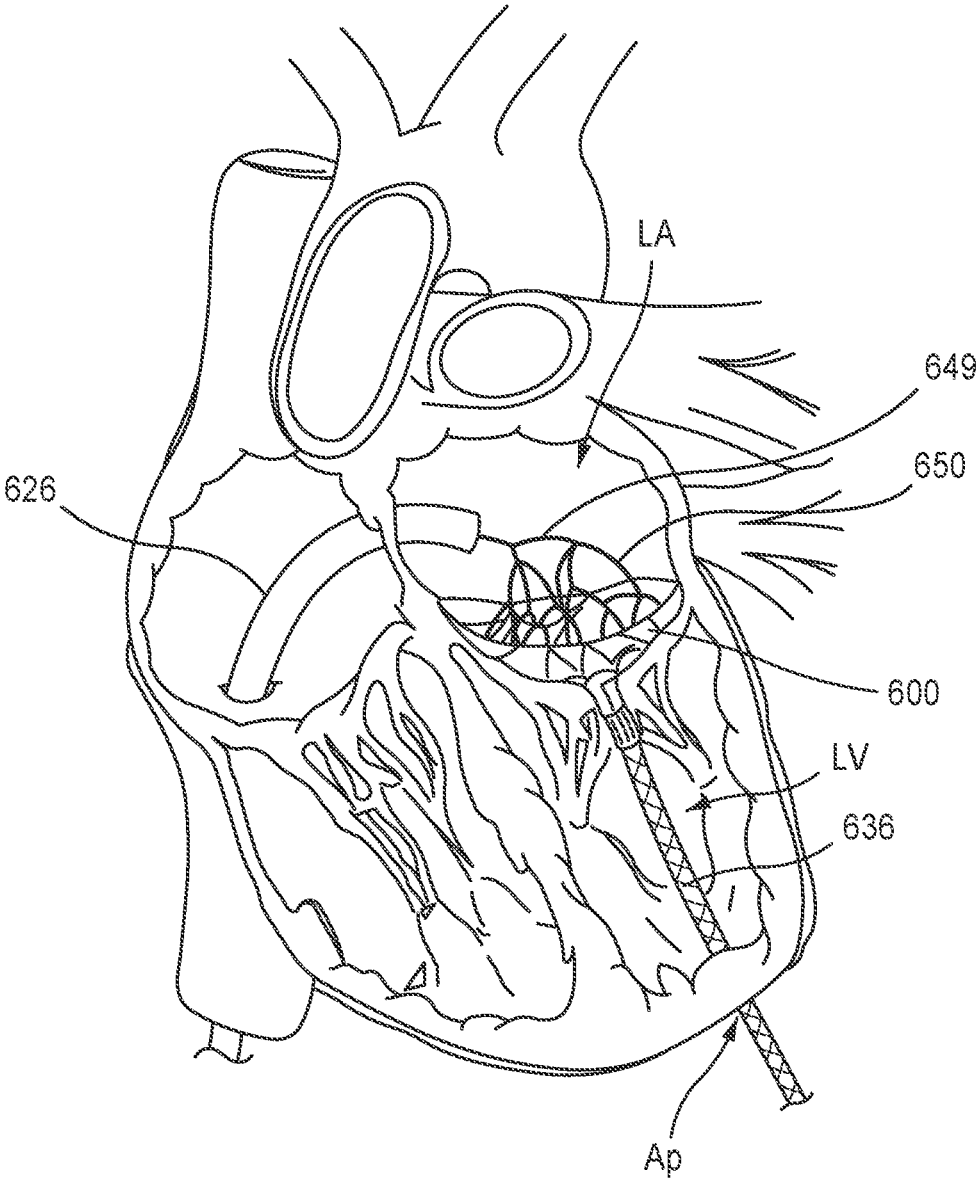

FIG. 29

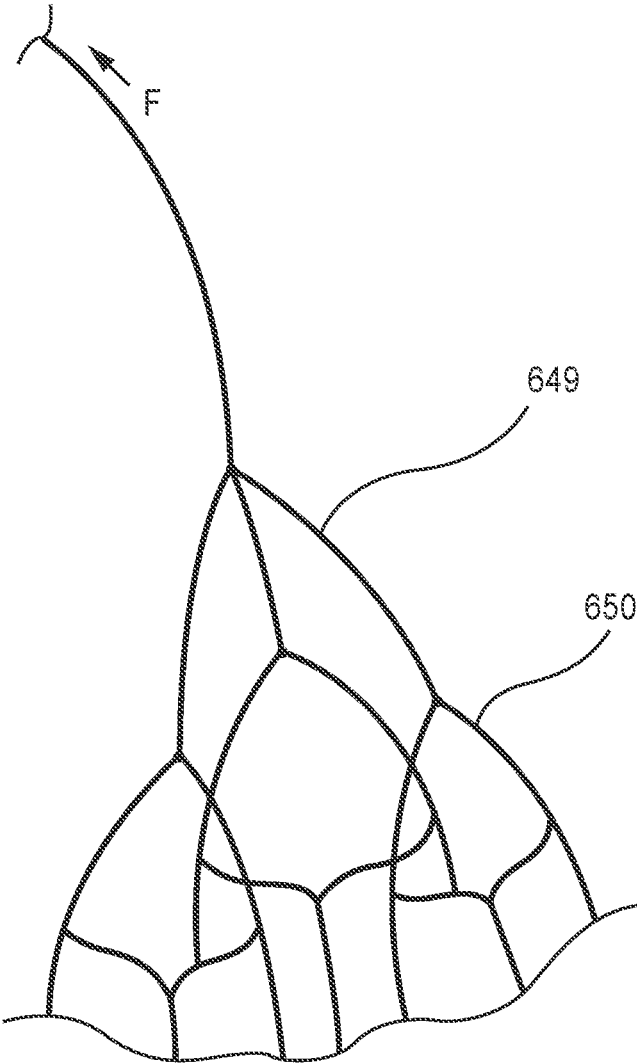

FIG. 30

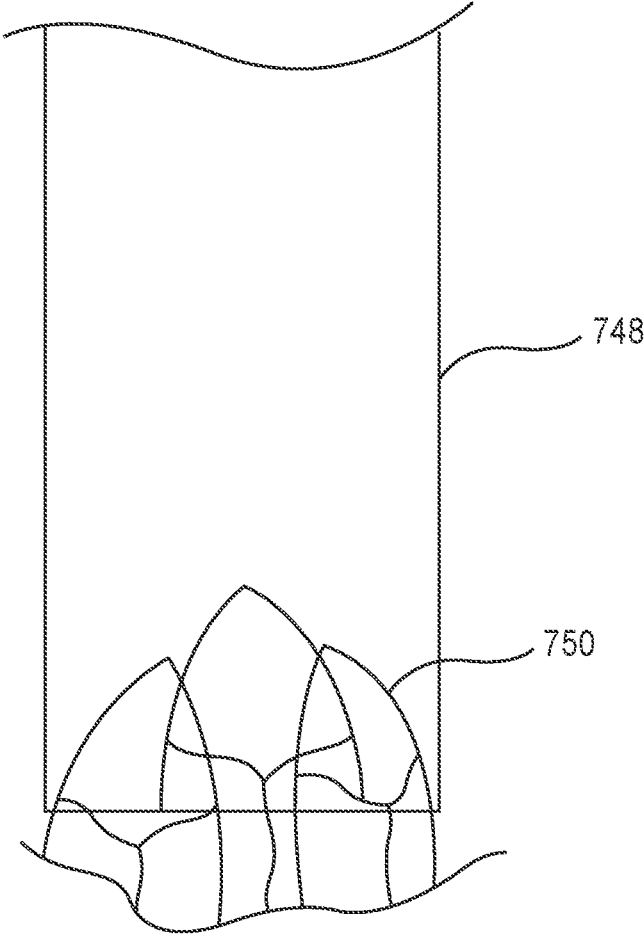

FIG. 31

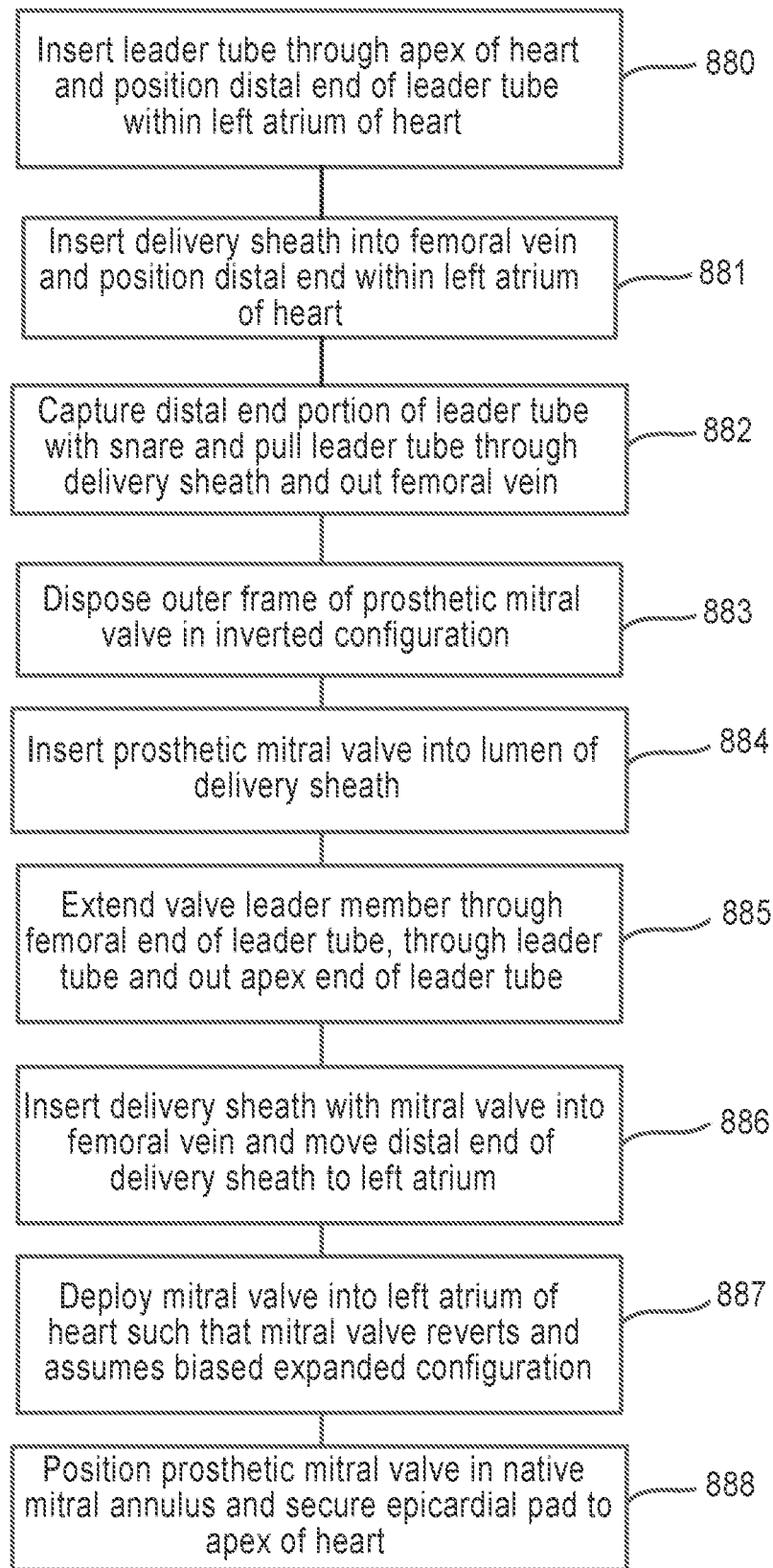

FIG. 32

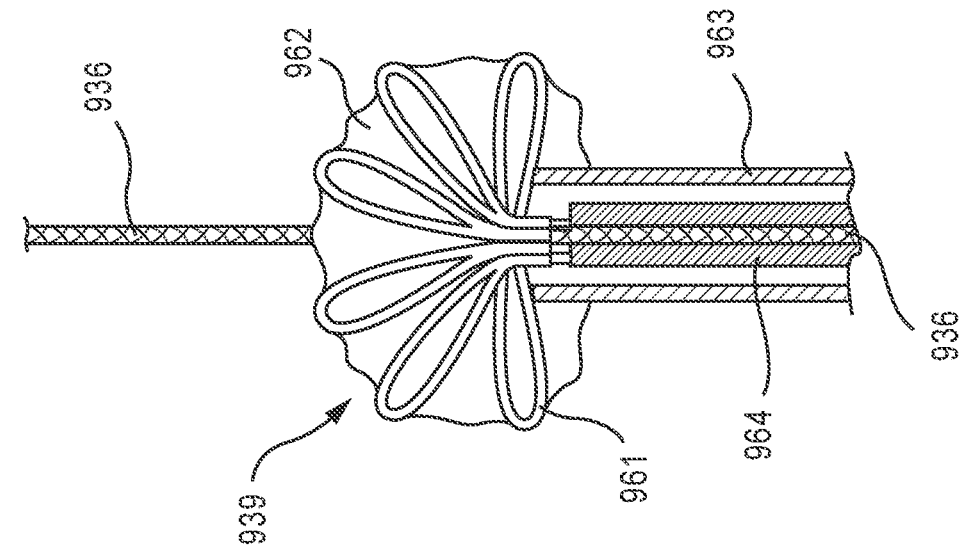

FIG. 33

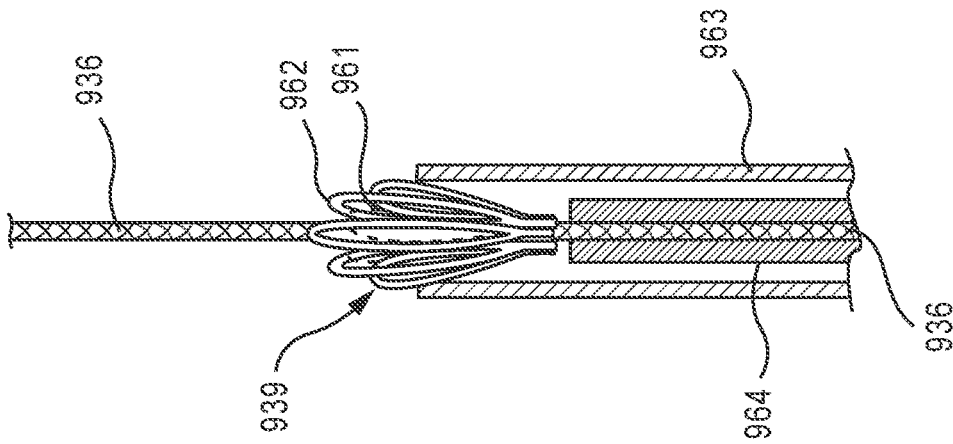

FIG. 34

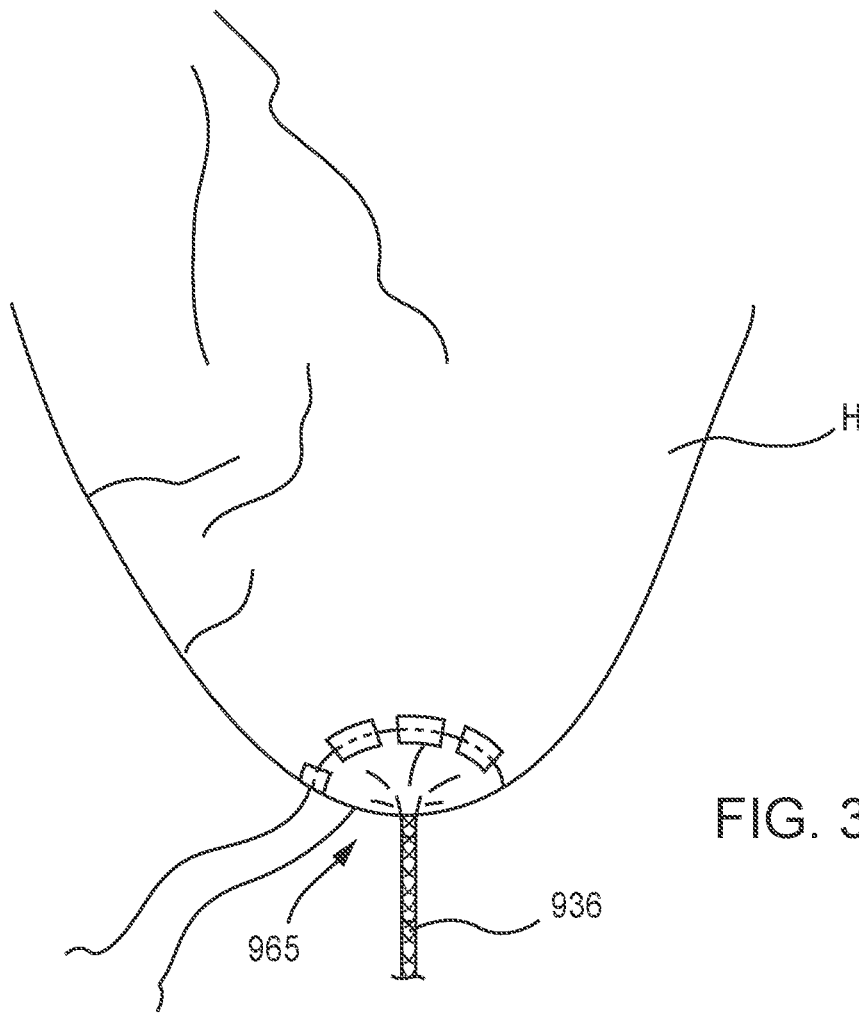

FIG. 35

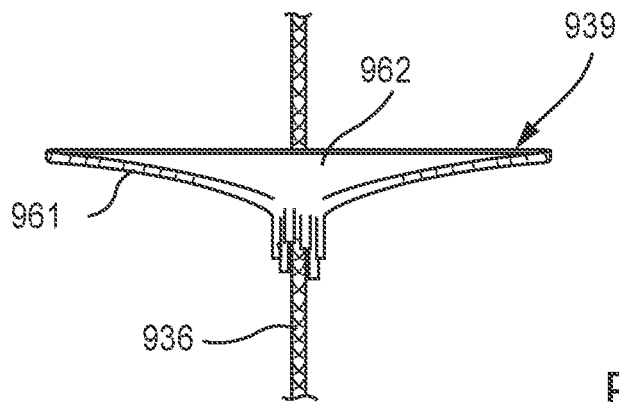

FIG. 36

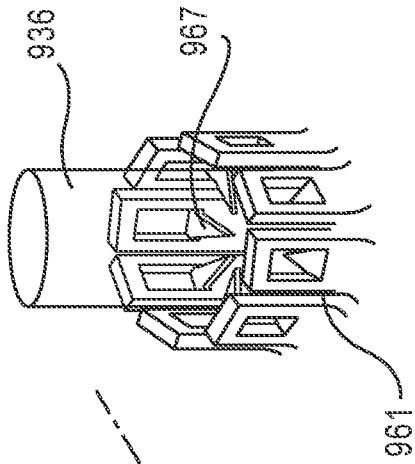

FIG. 38

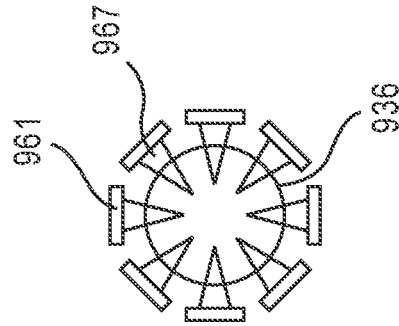

FIG. 39

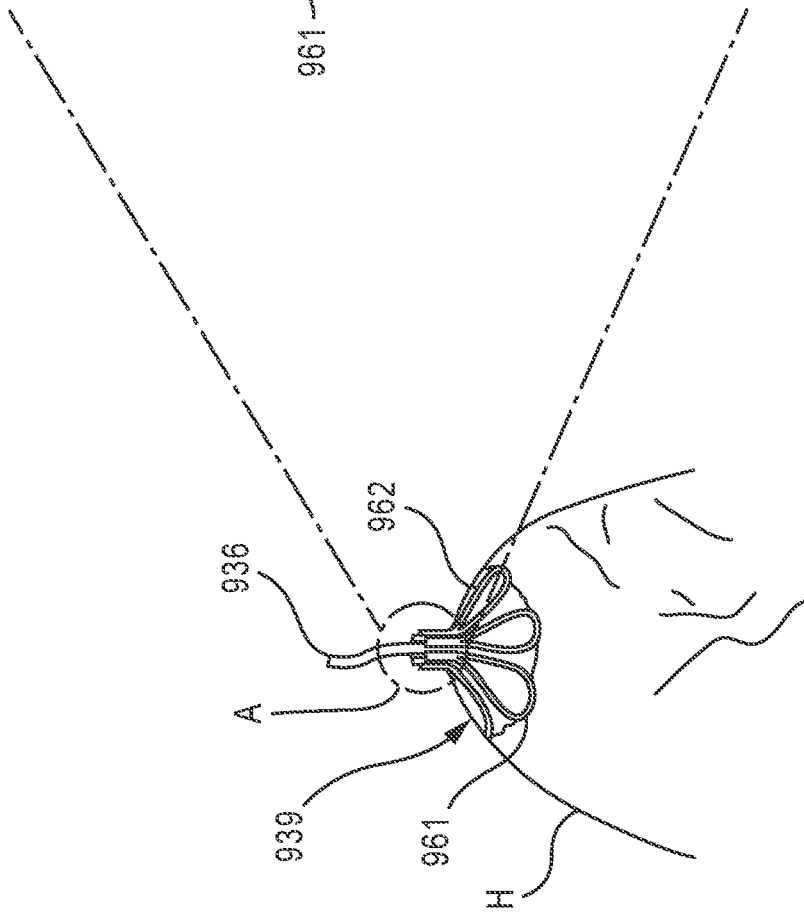

FIG. 37

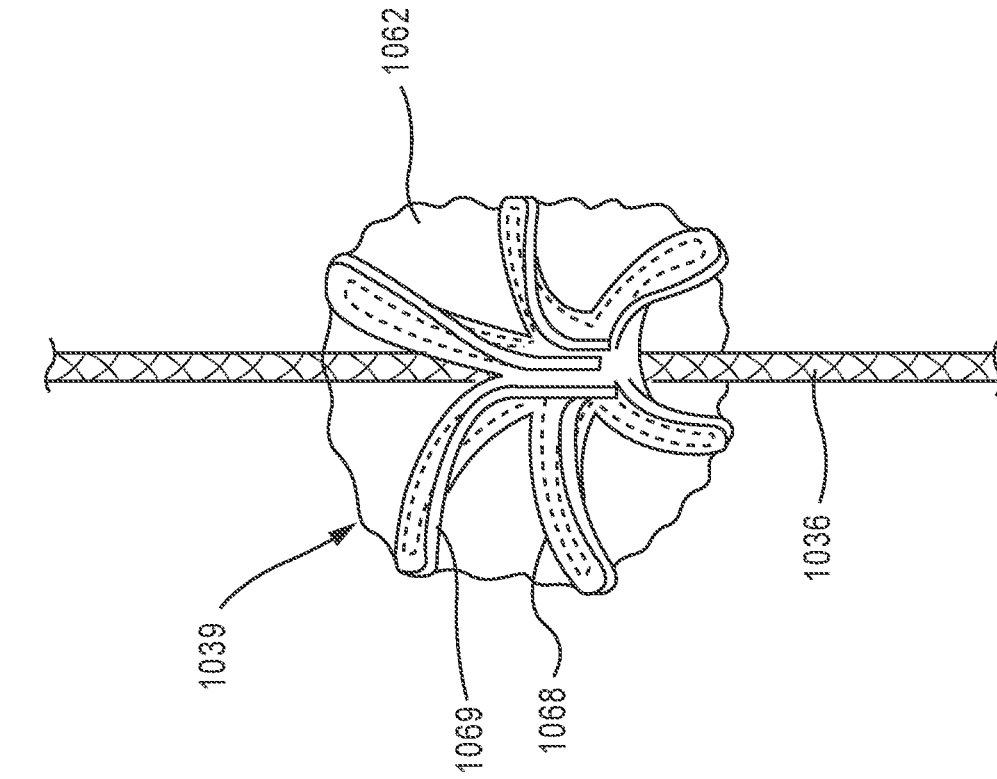

FIG. 40

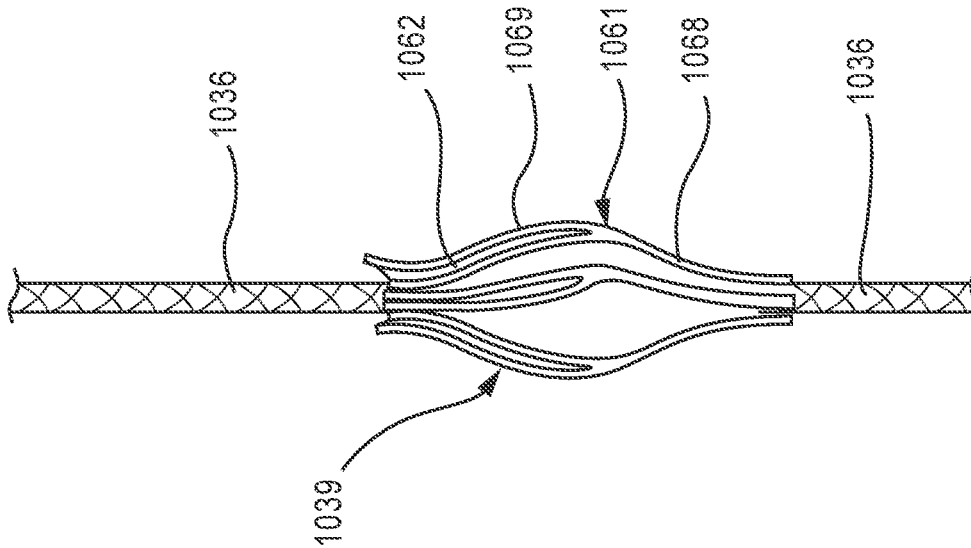

FIG. 41

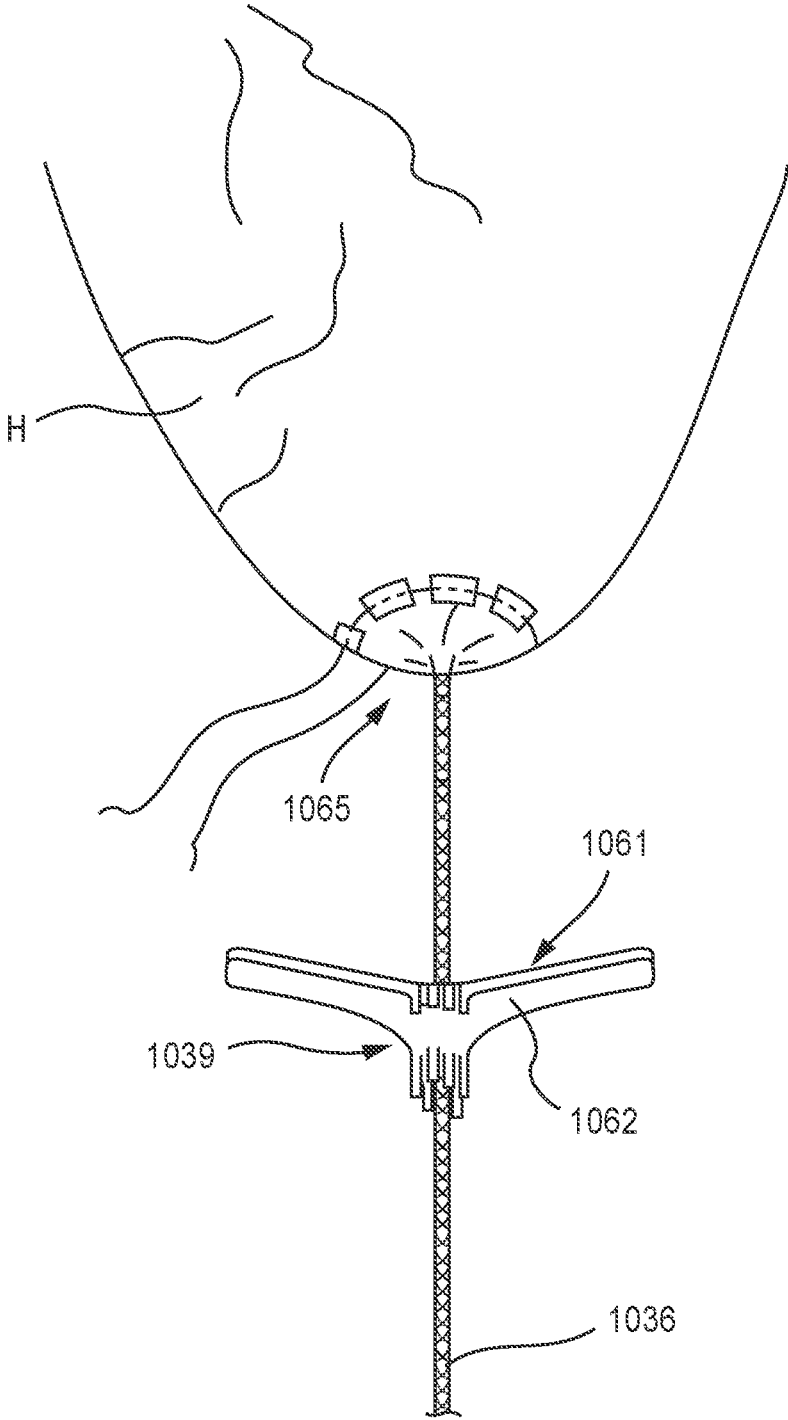

FIG. 42

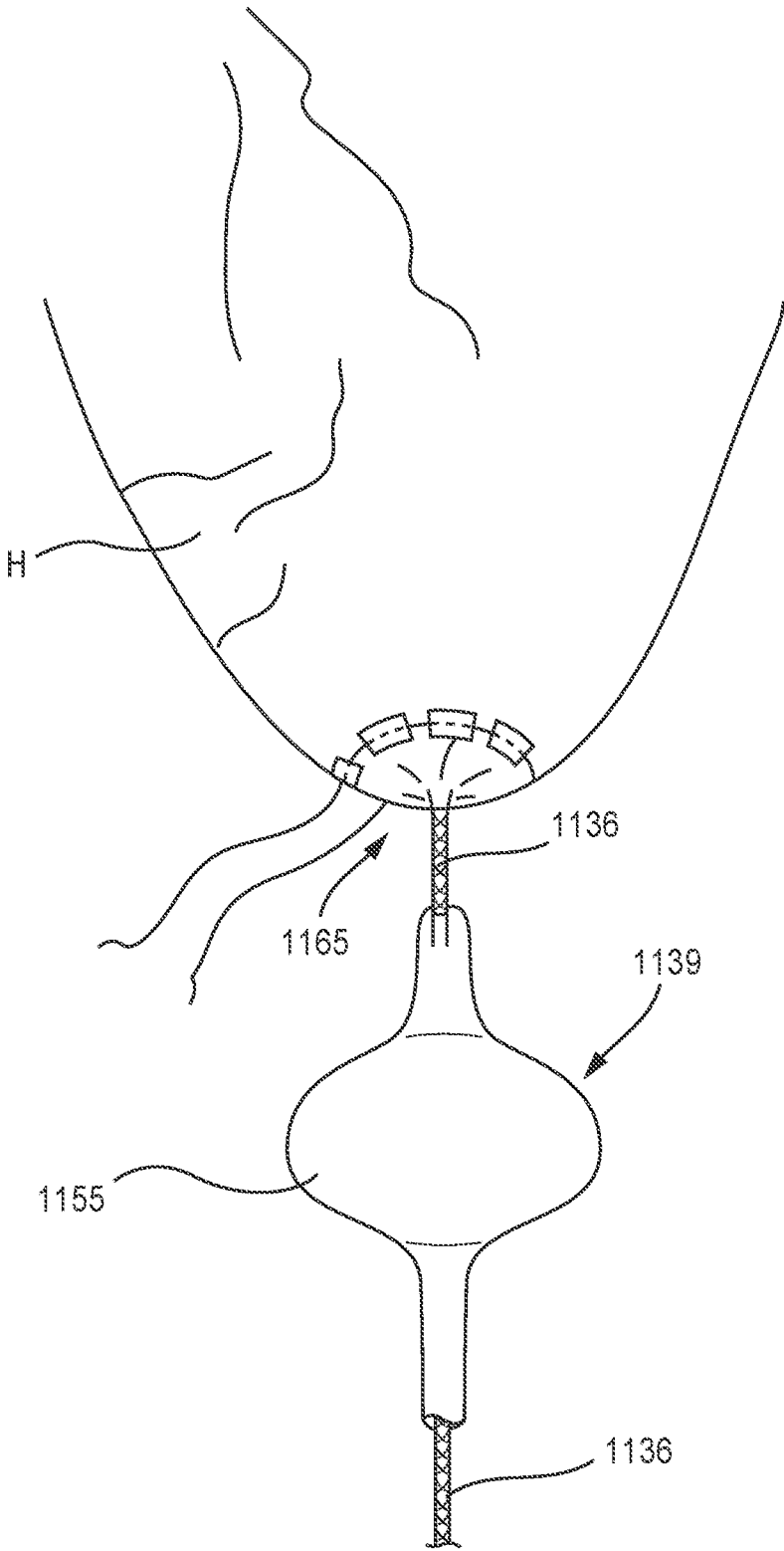

FIG. 43

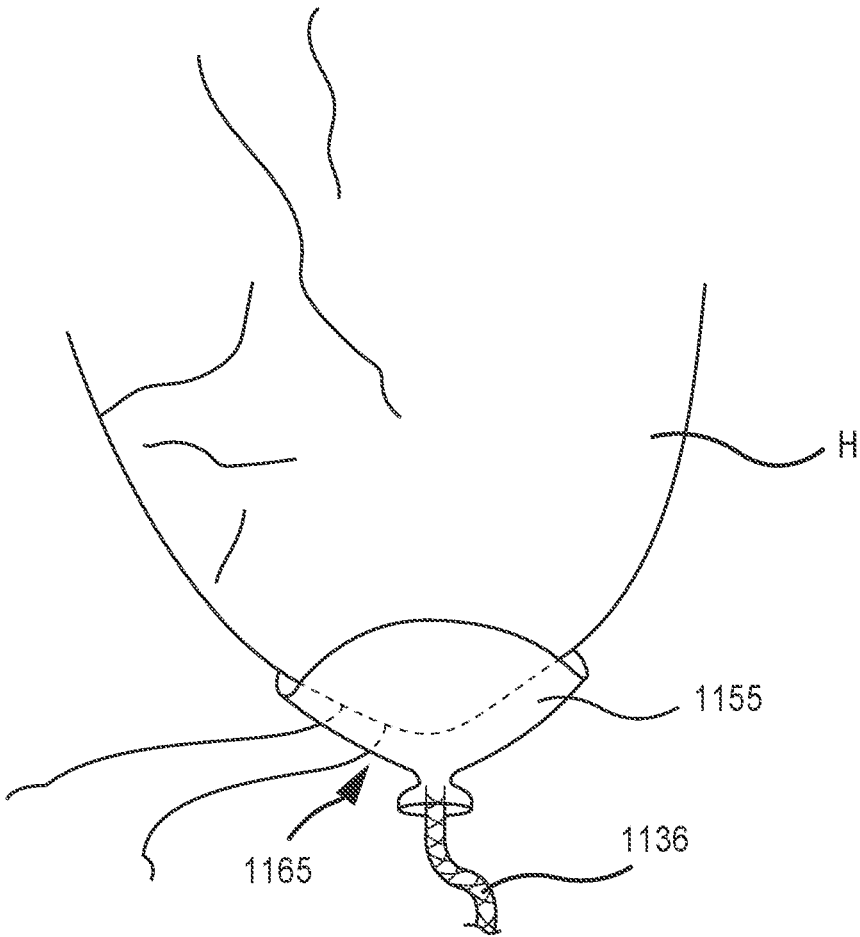

FIG. 44

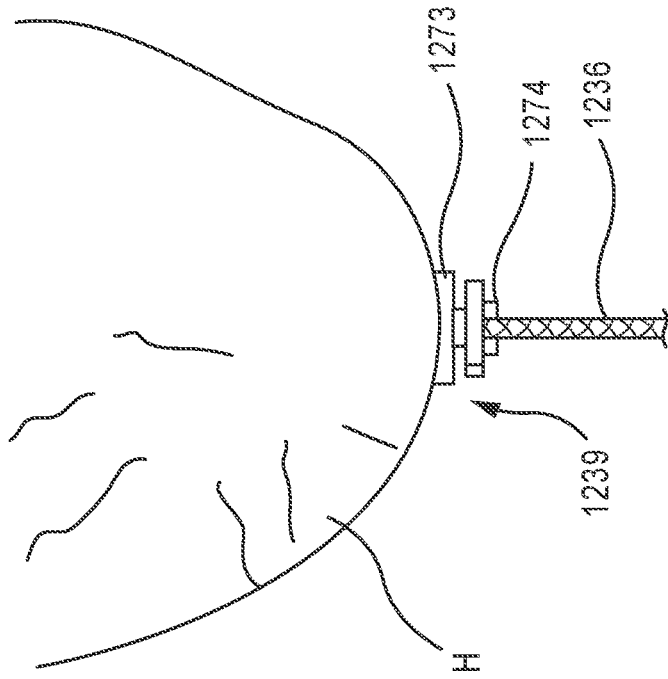

FIG. 45

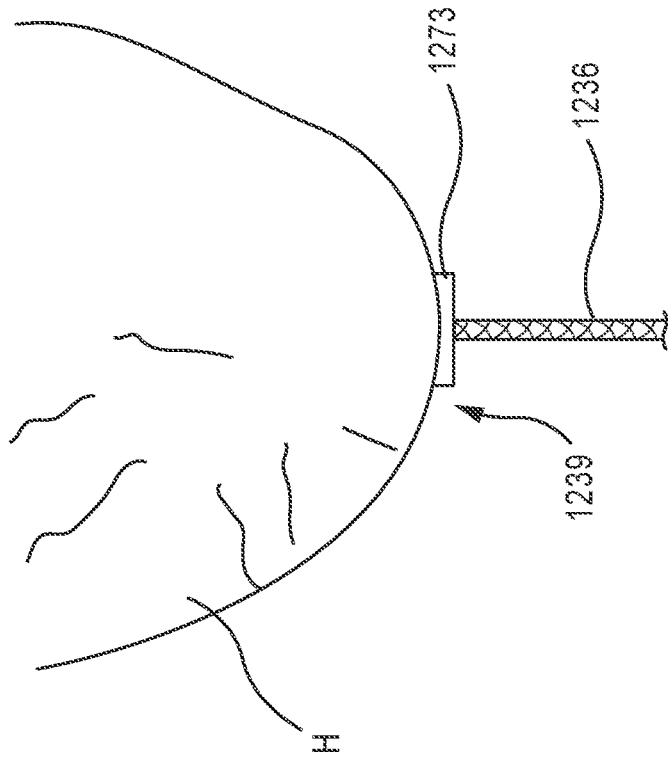

FIG. 46

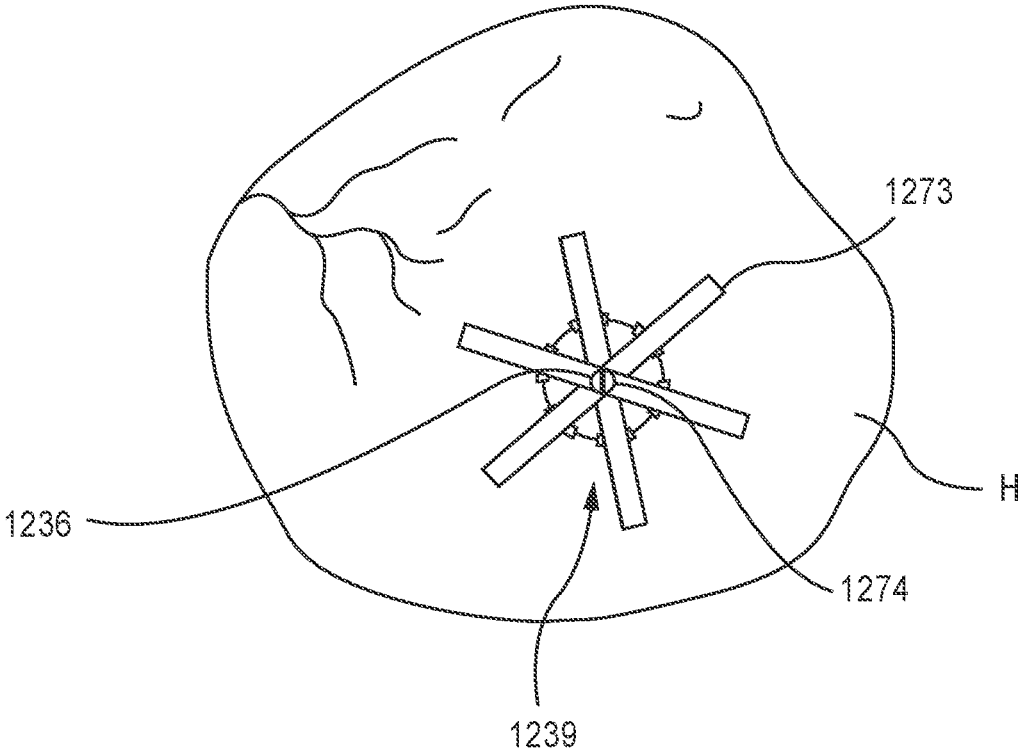

FIG. 47

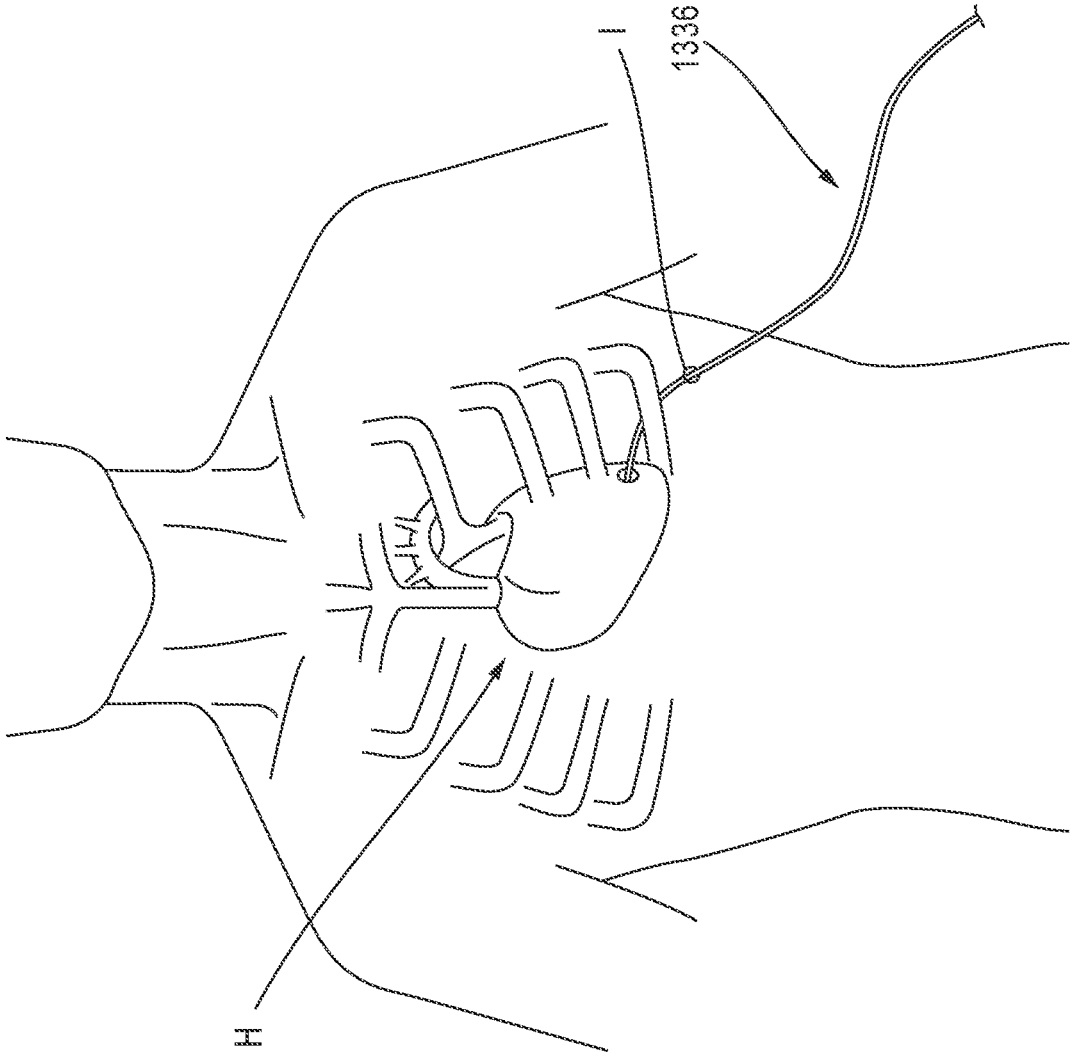

FIG. 48

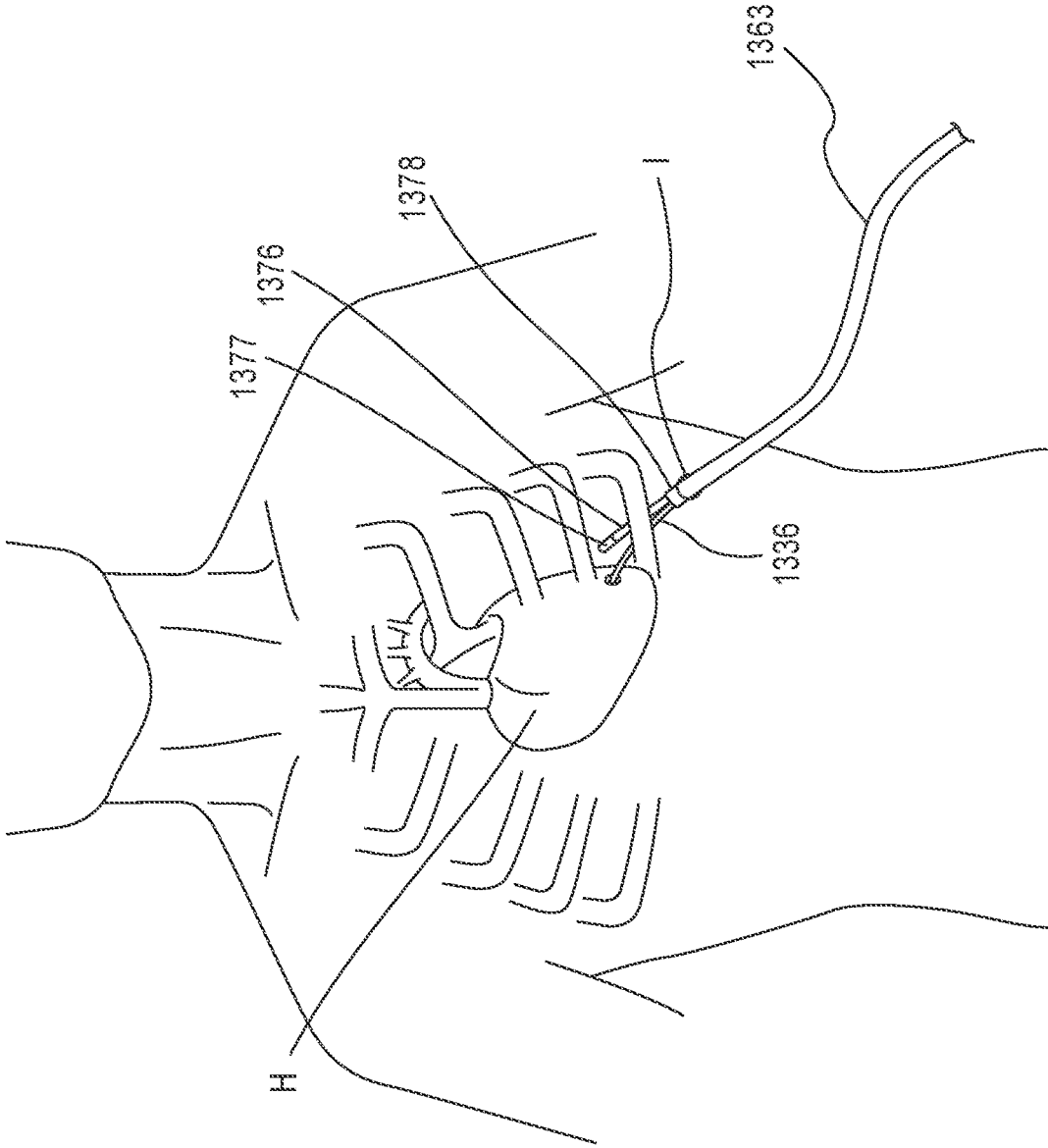

FIG. 49

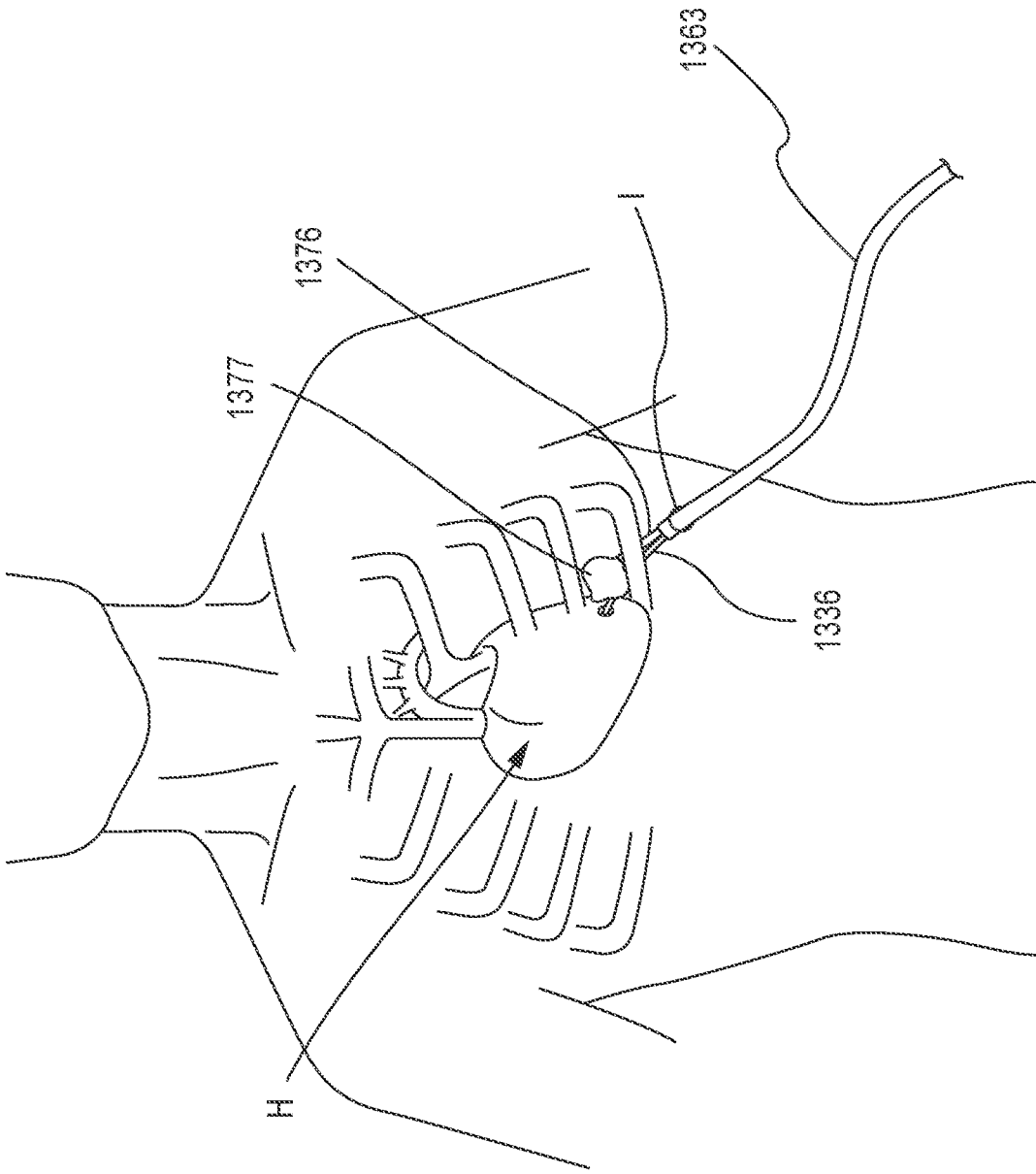

FIG. 50

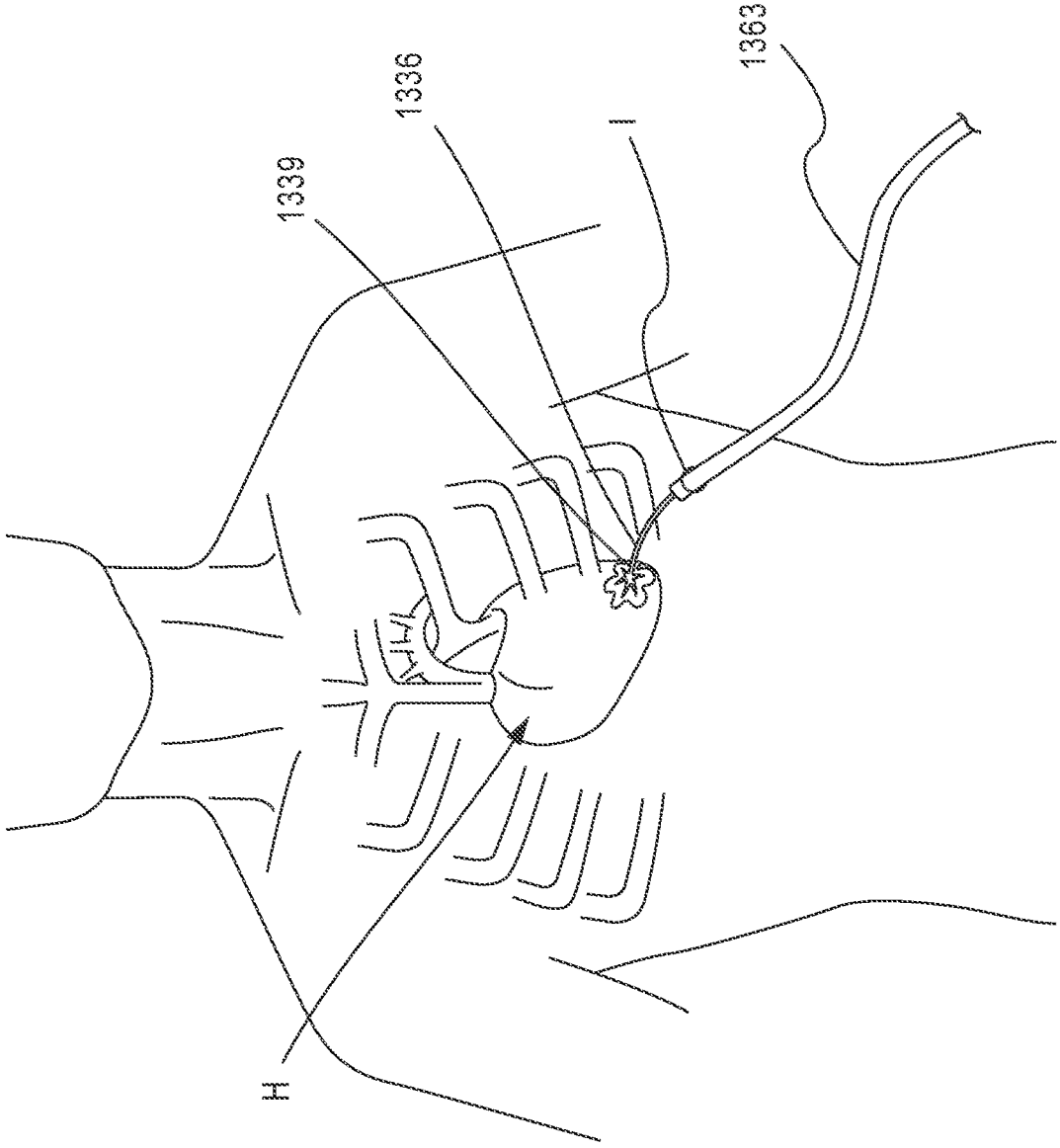

FIG. 51

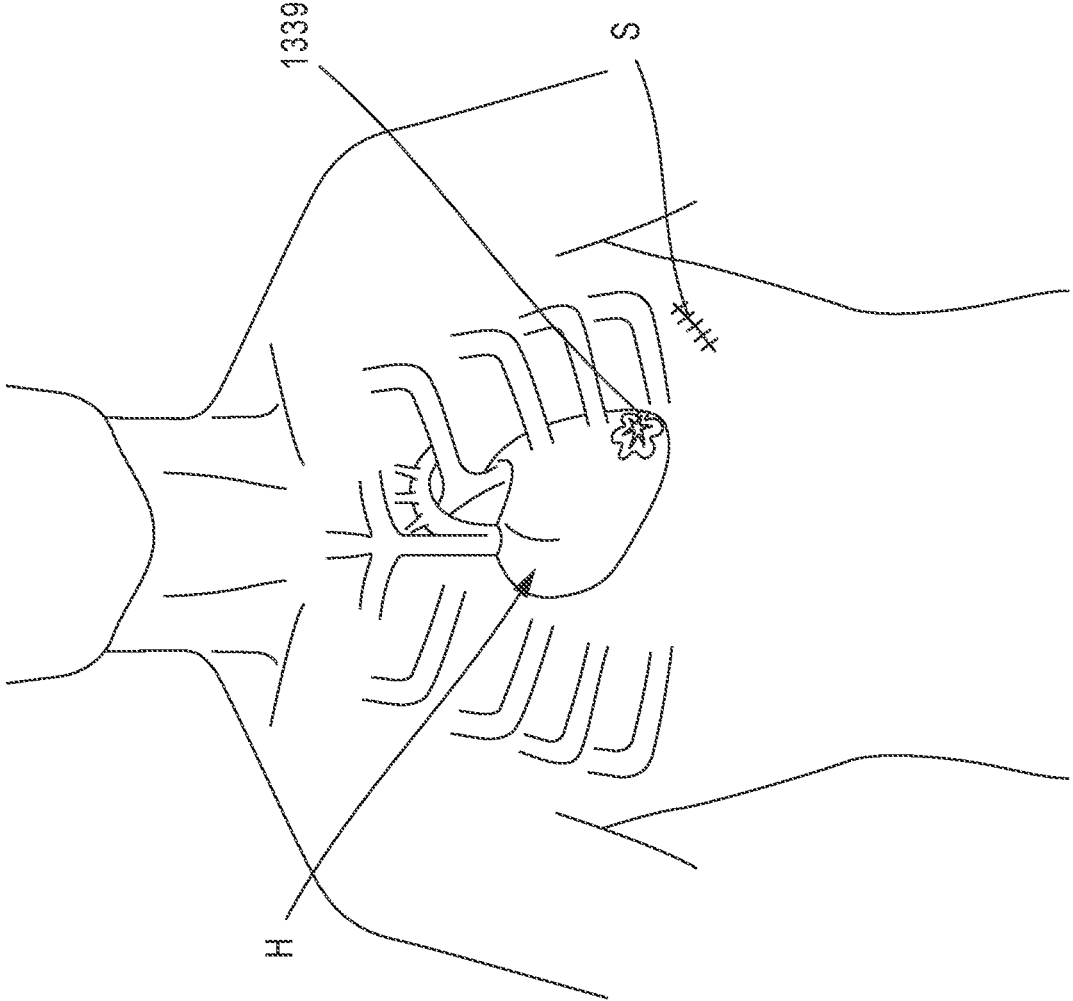

FIG. 52

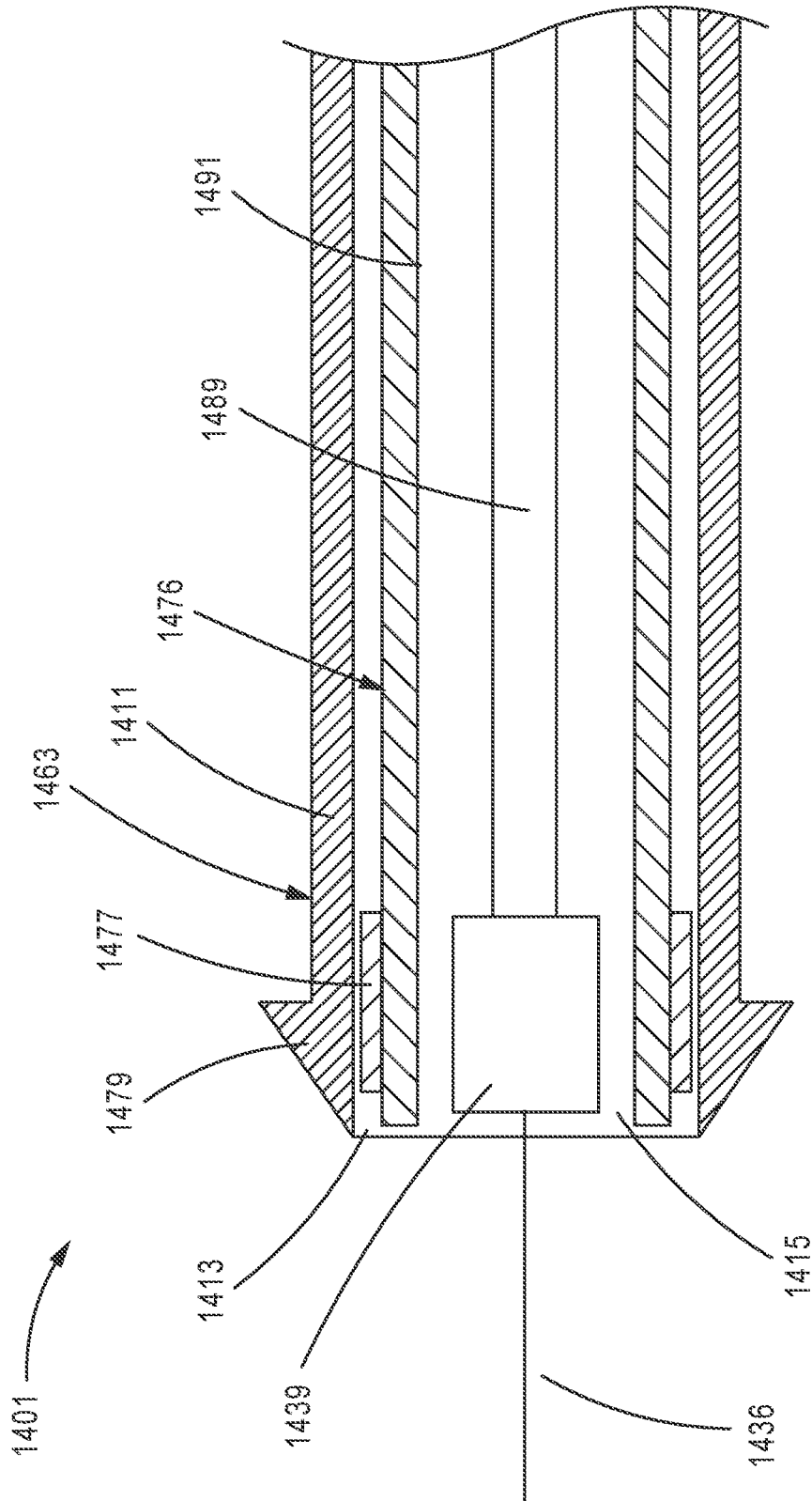

FIG. 53

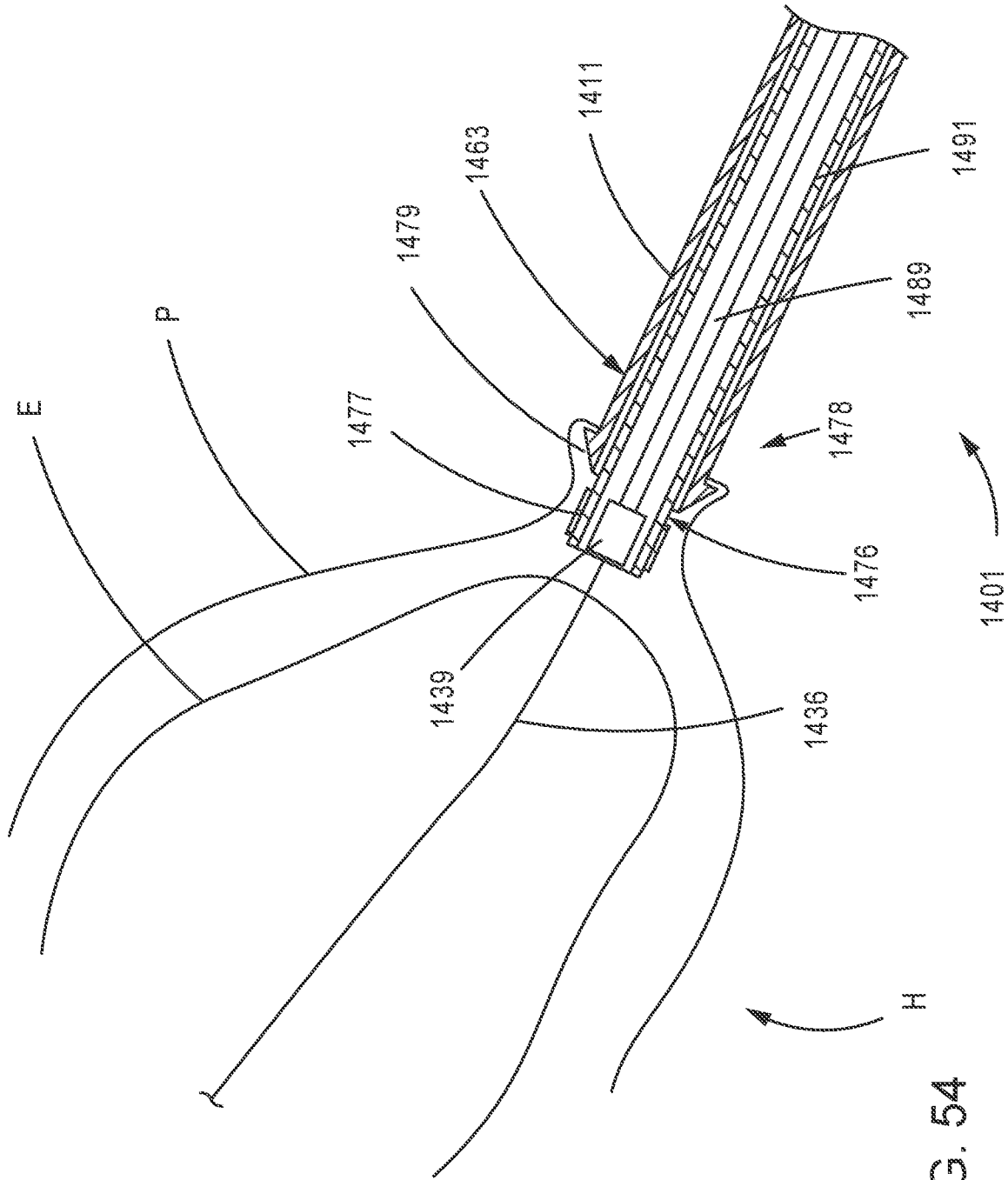

FIG. 54

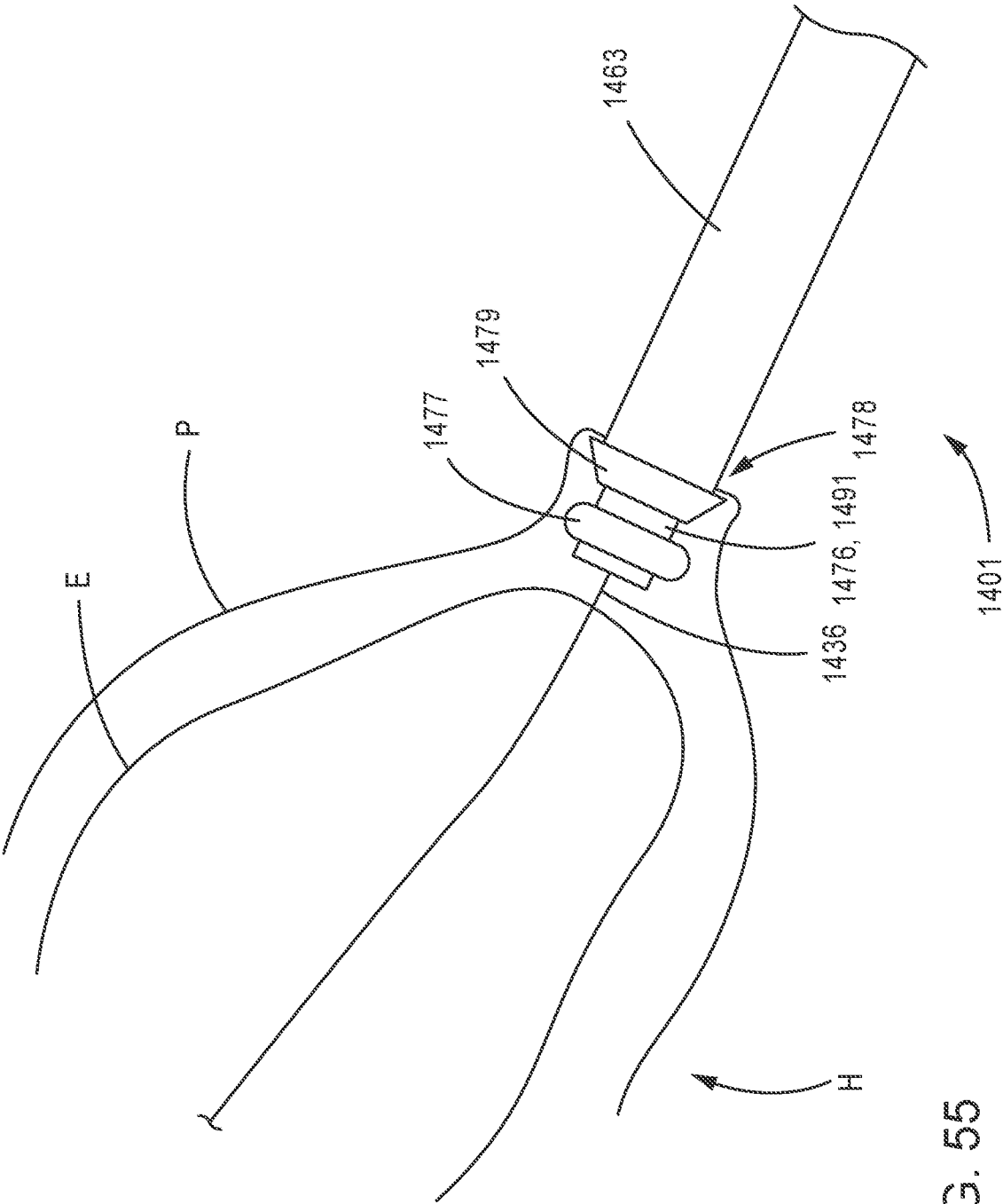

FIG. 55

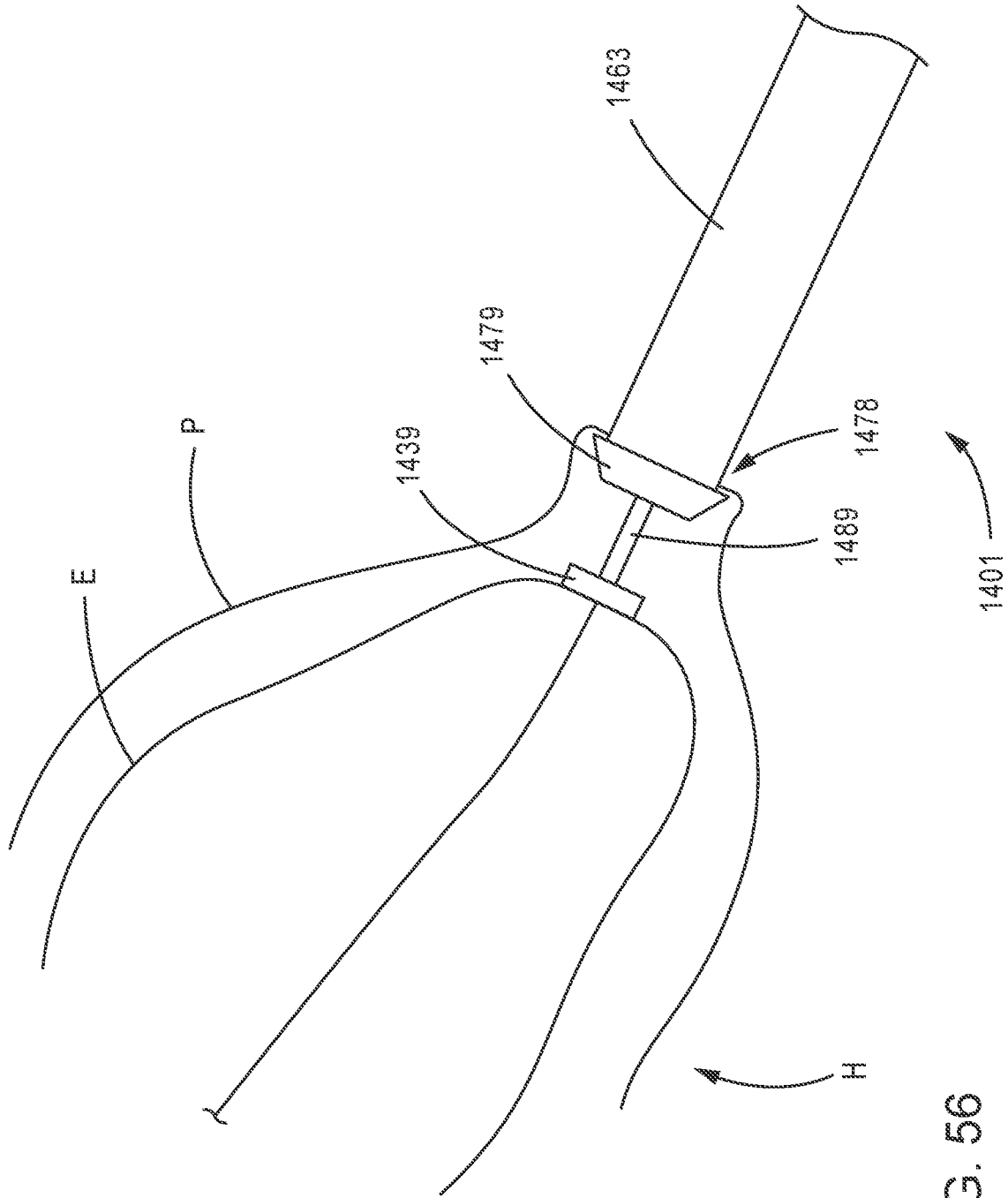

FIG. 56

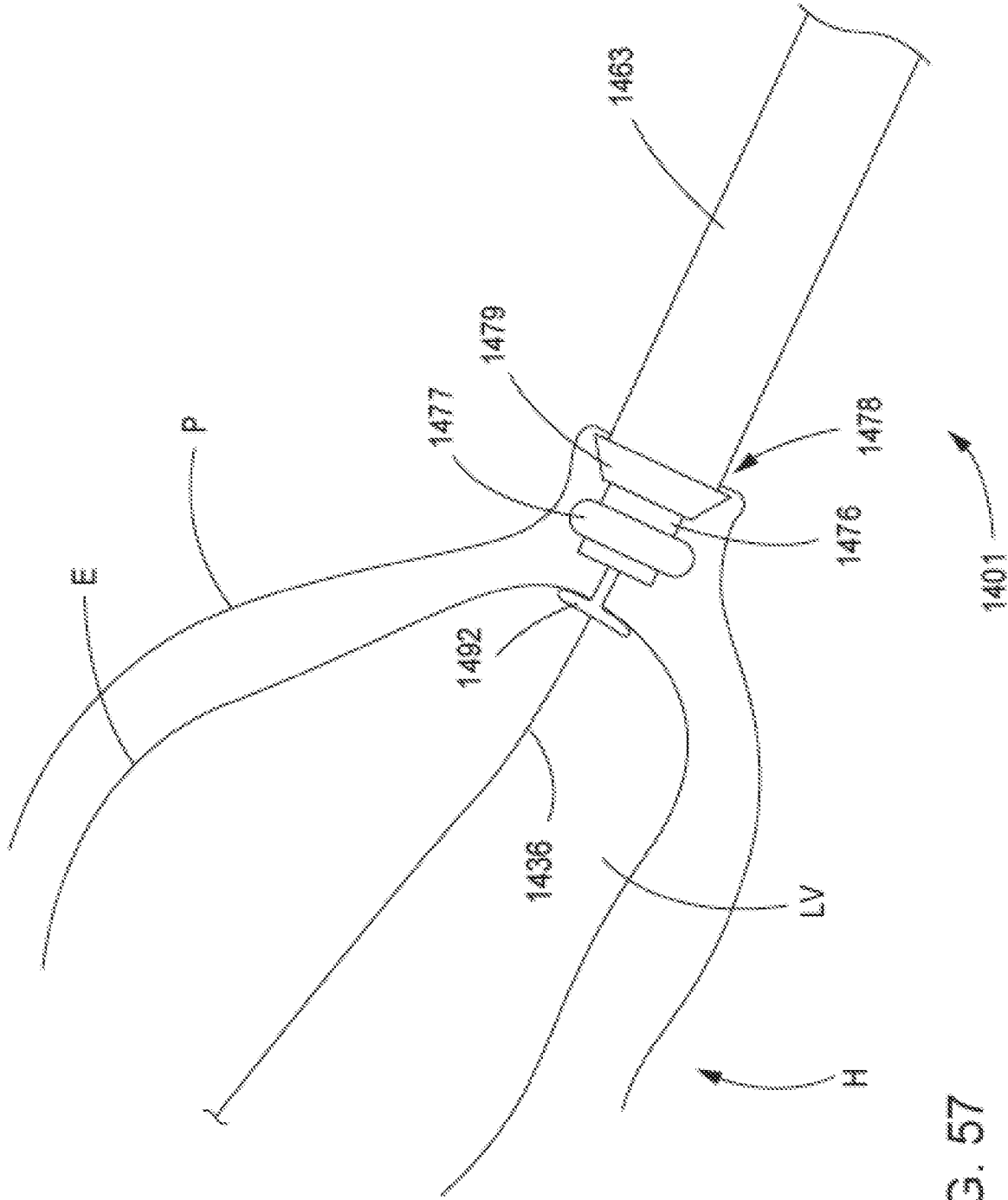

FIG. 57

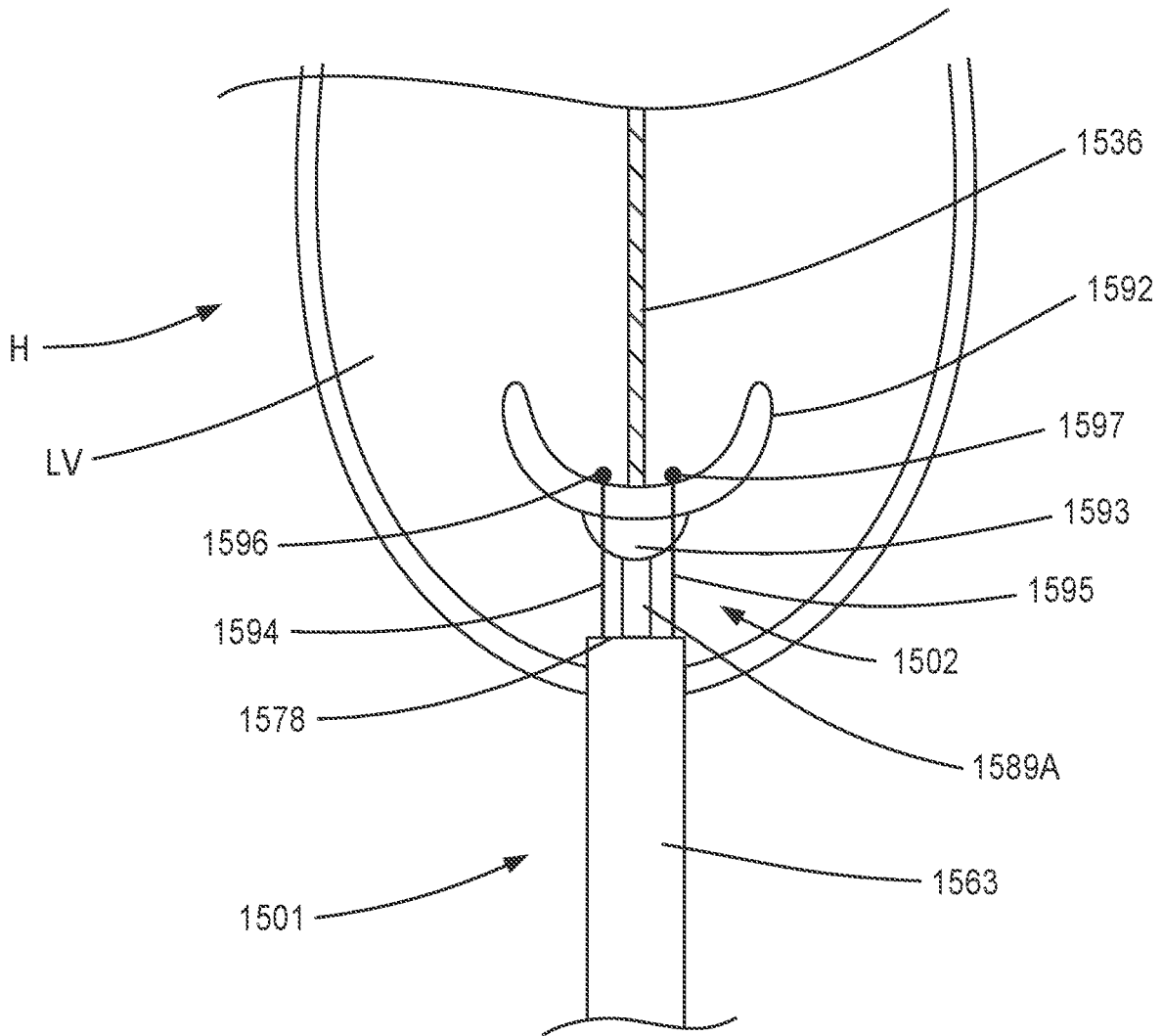

FIG. 58

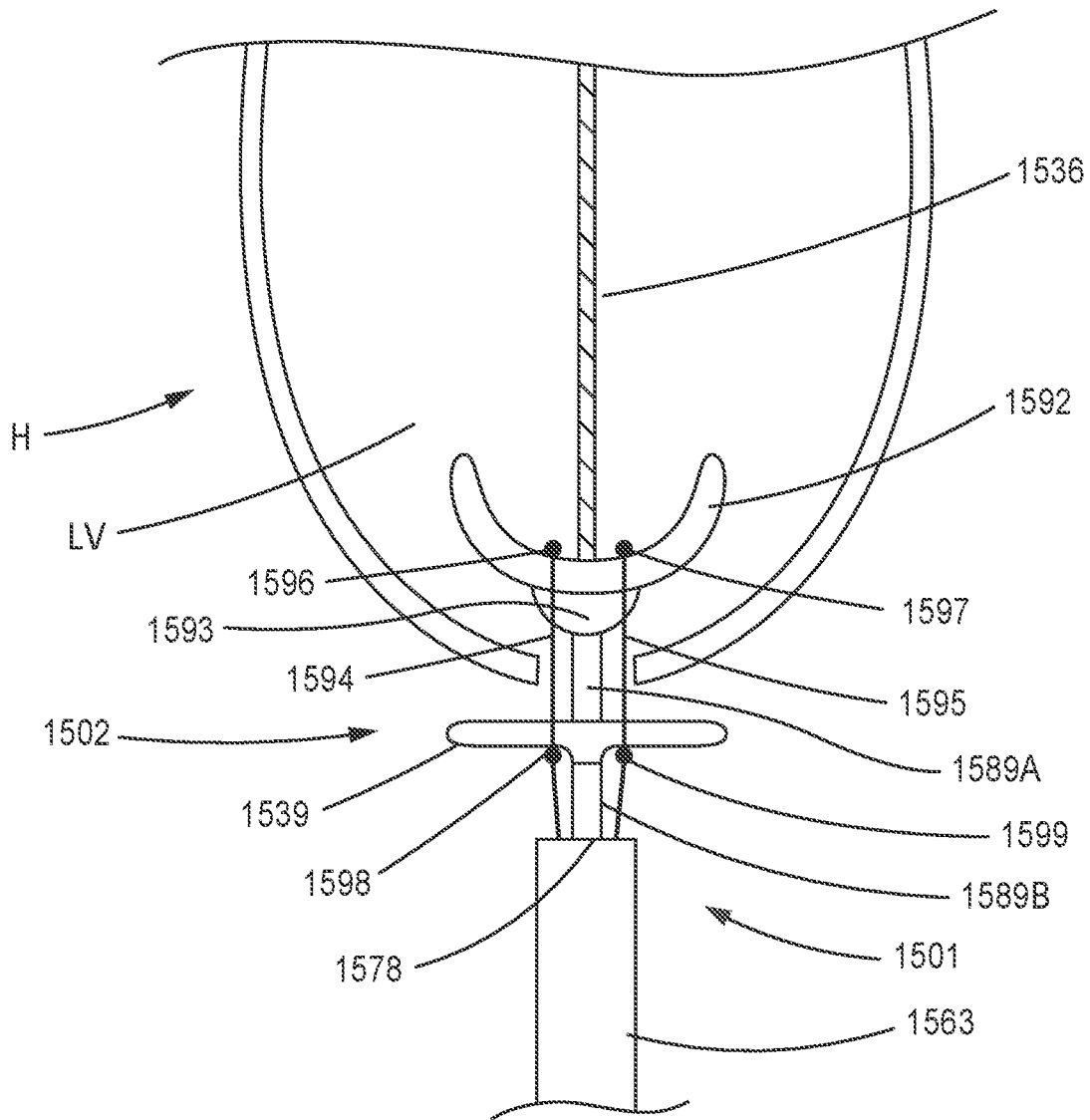

FIG. 59

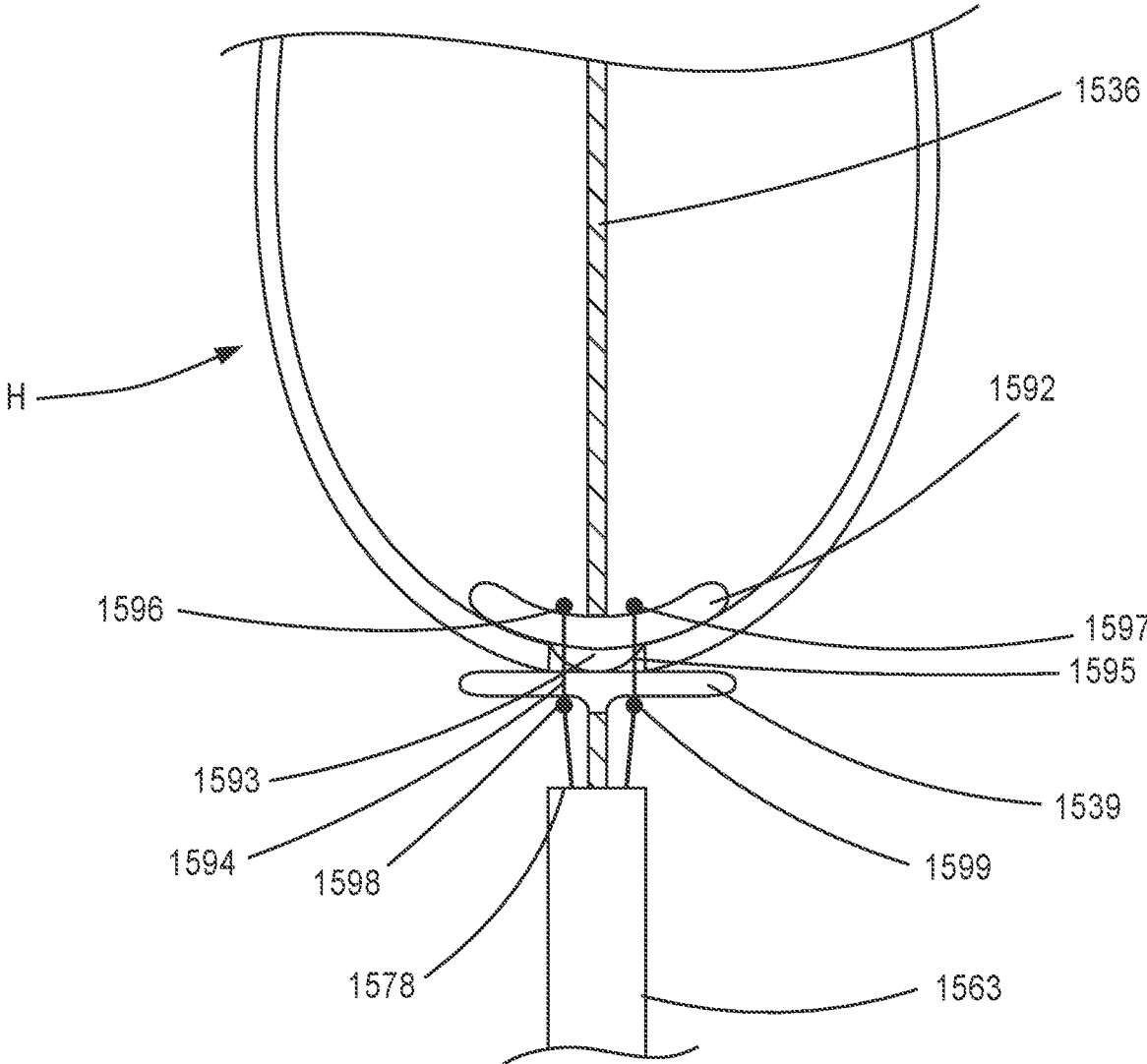

FIG. 60

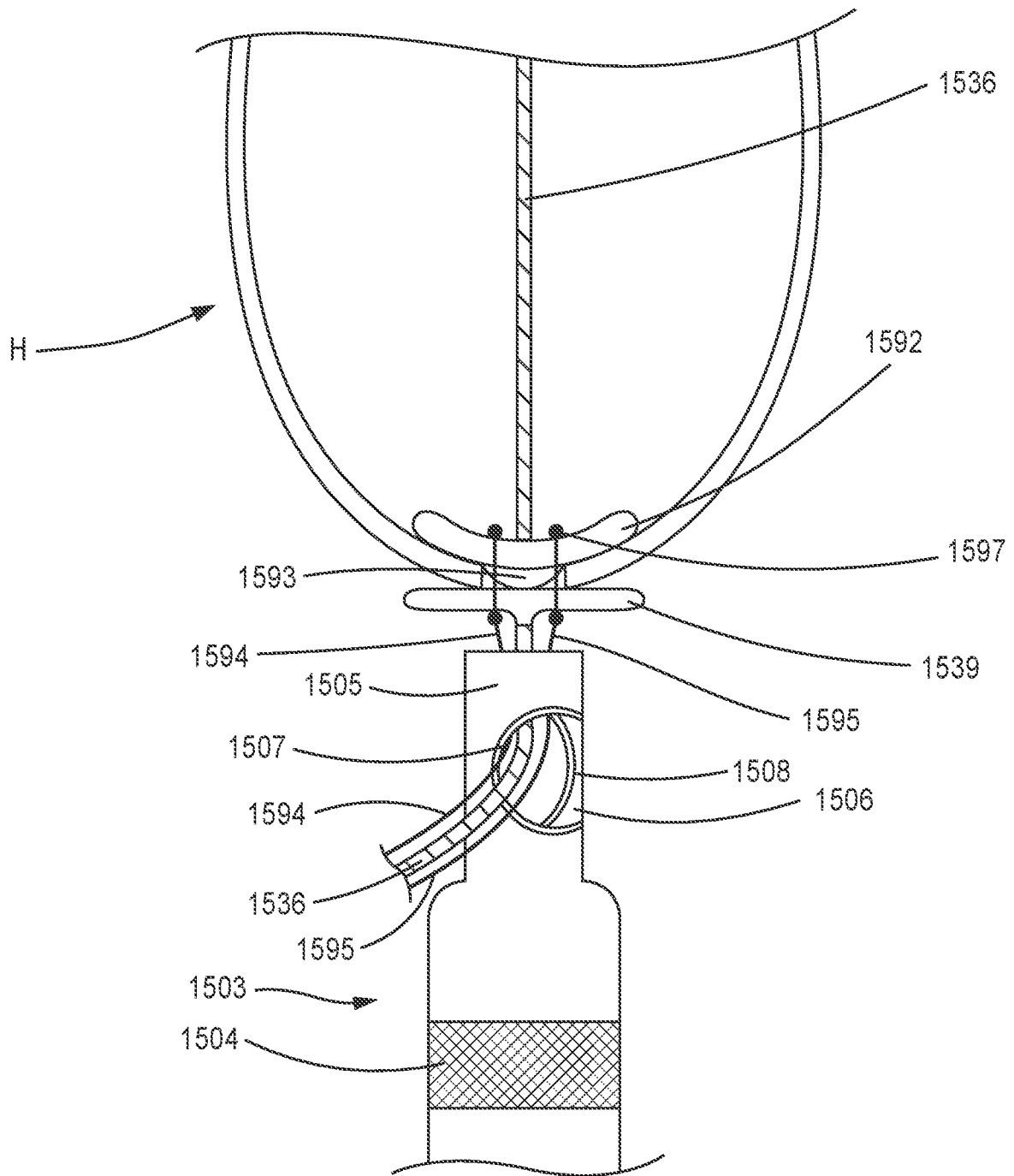

FIG. 61

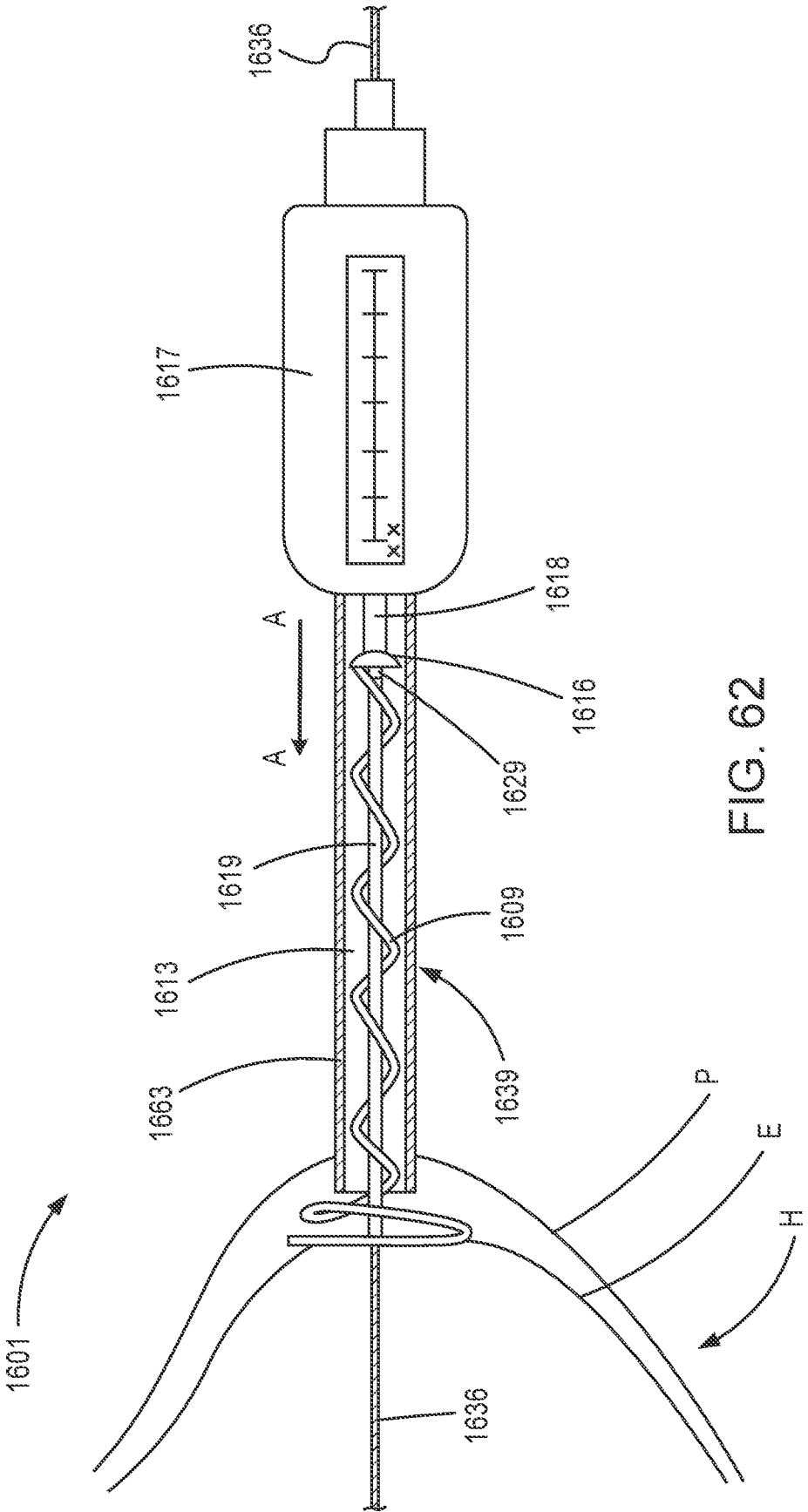

FIG. 62

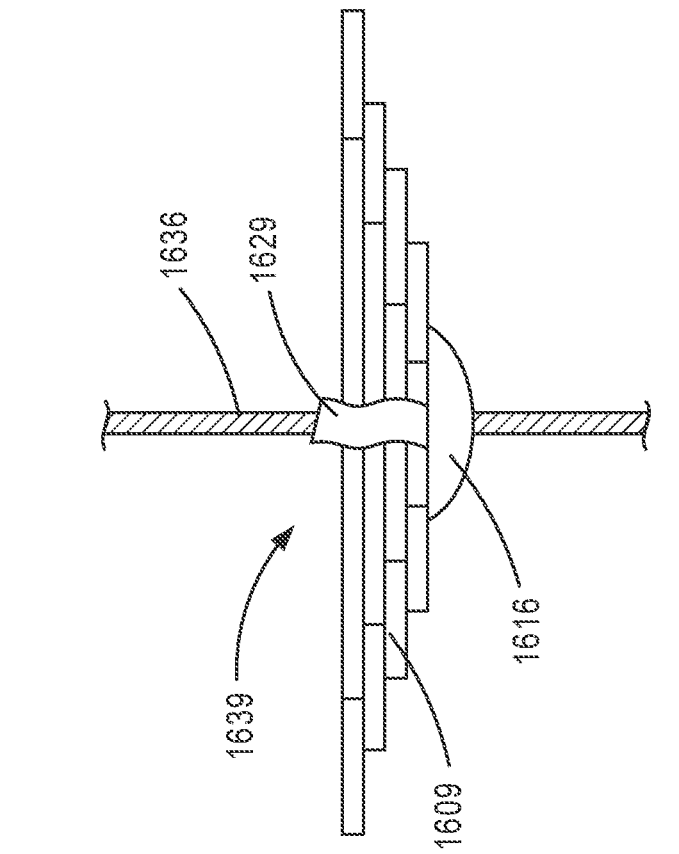

FIG. 64

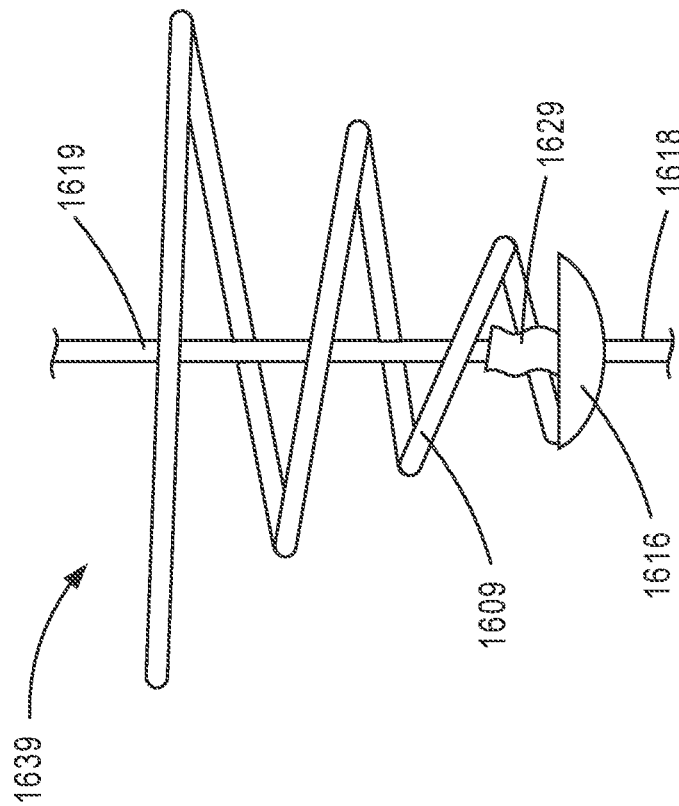

FIG. 63

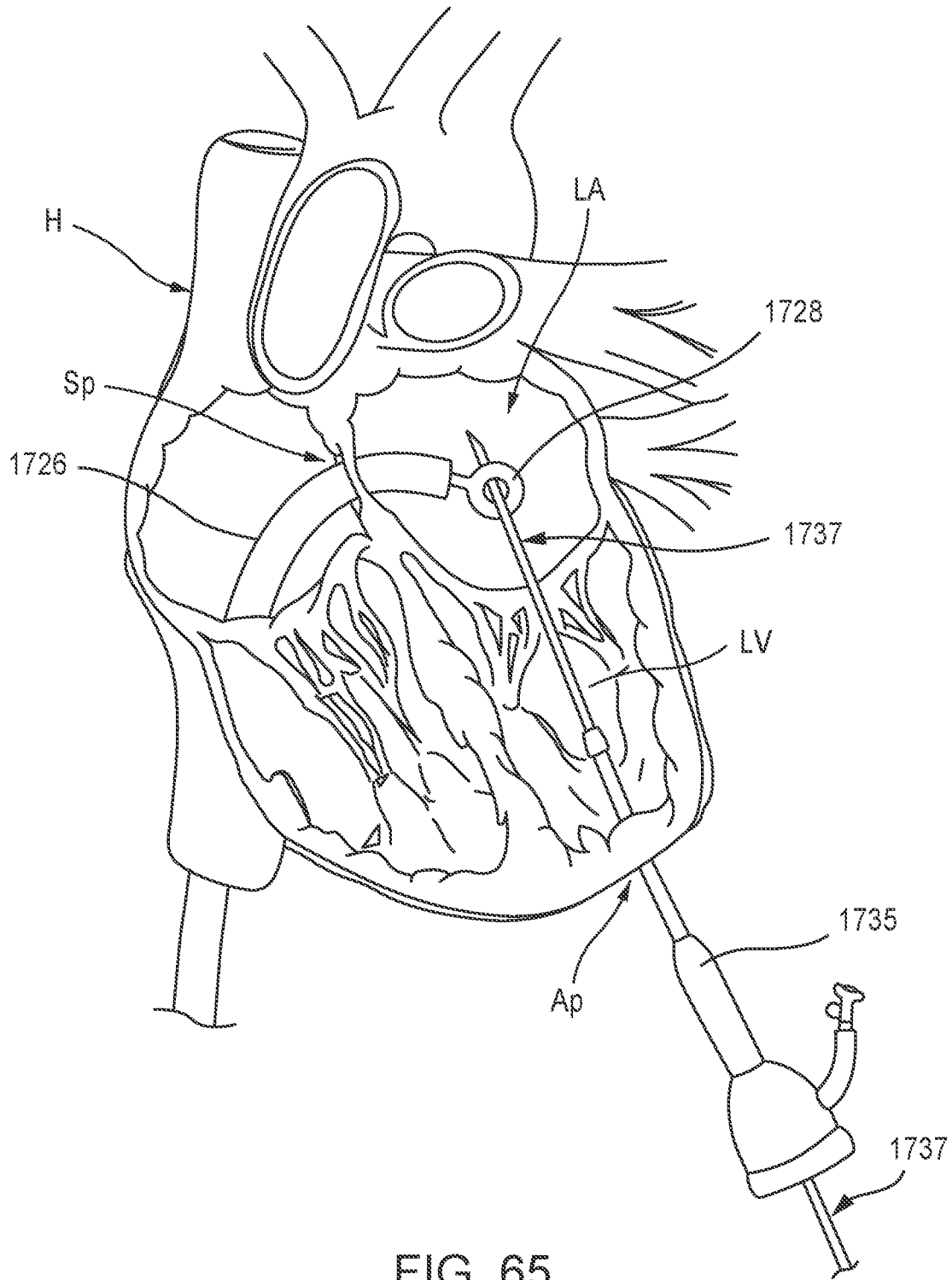

FIG. 65

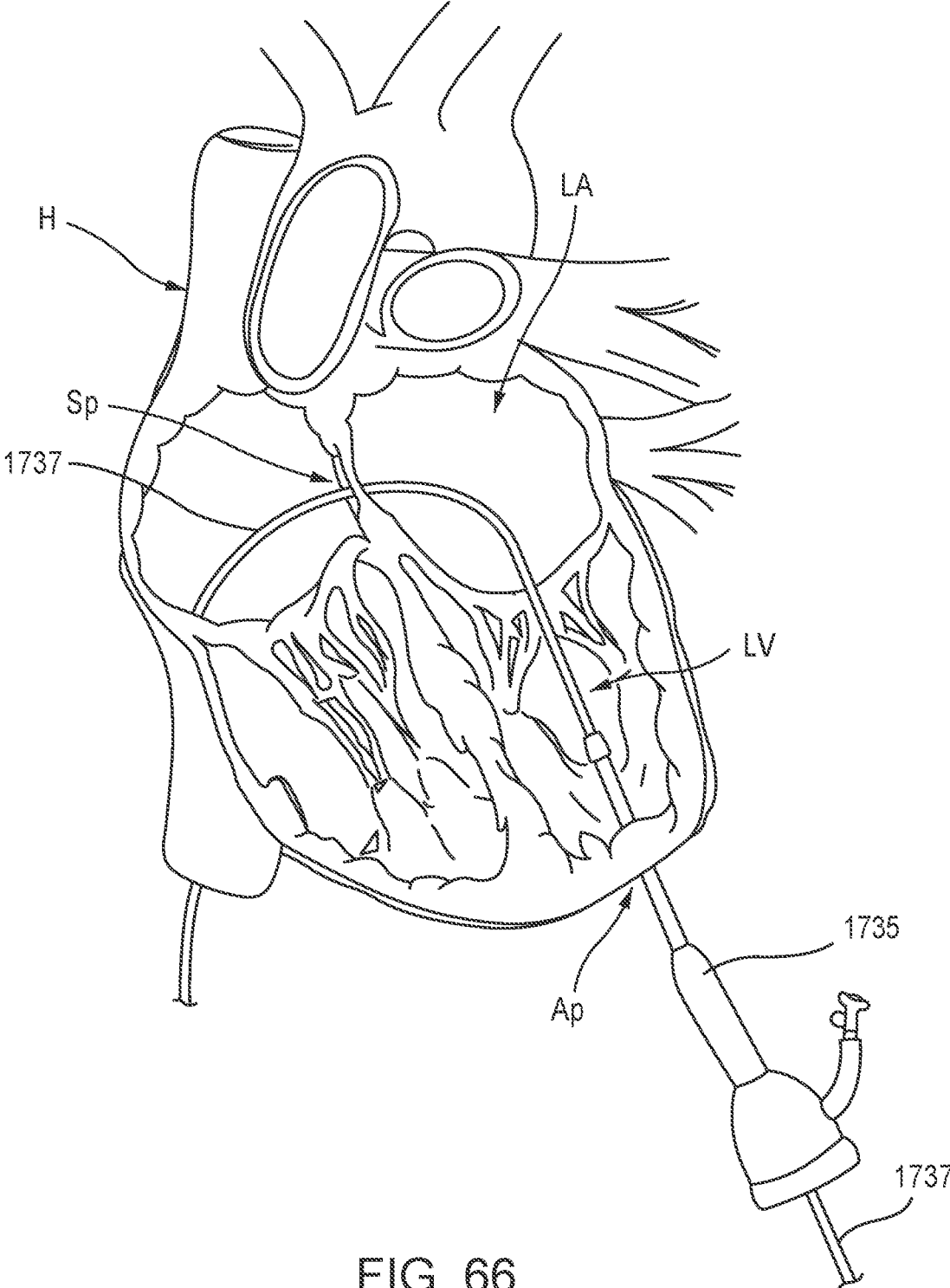

FIG. 66

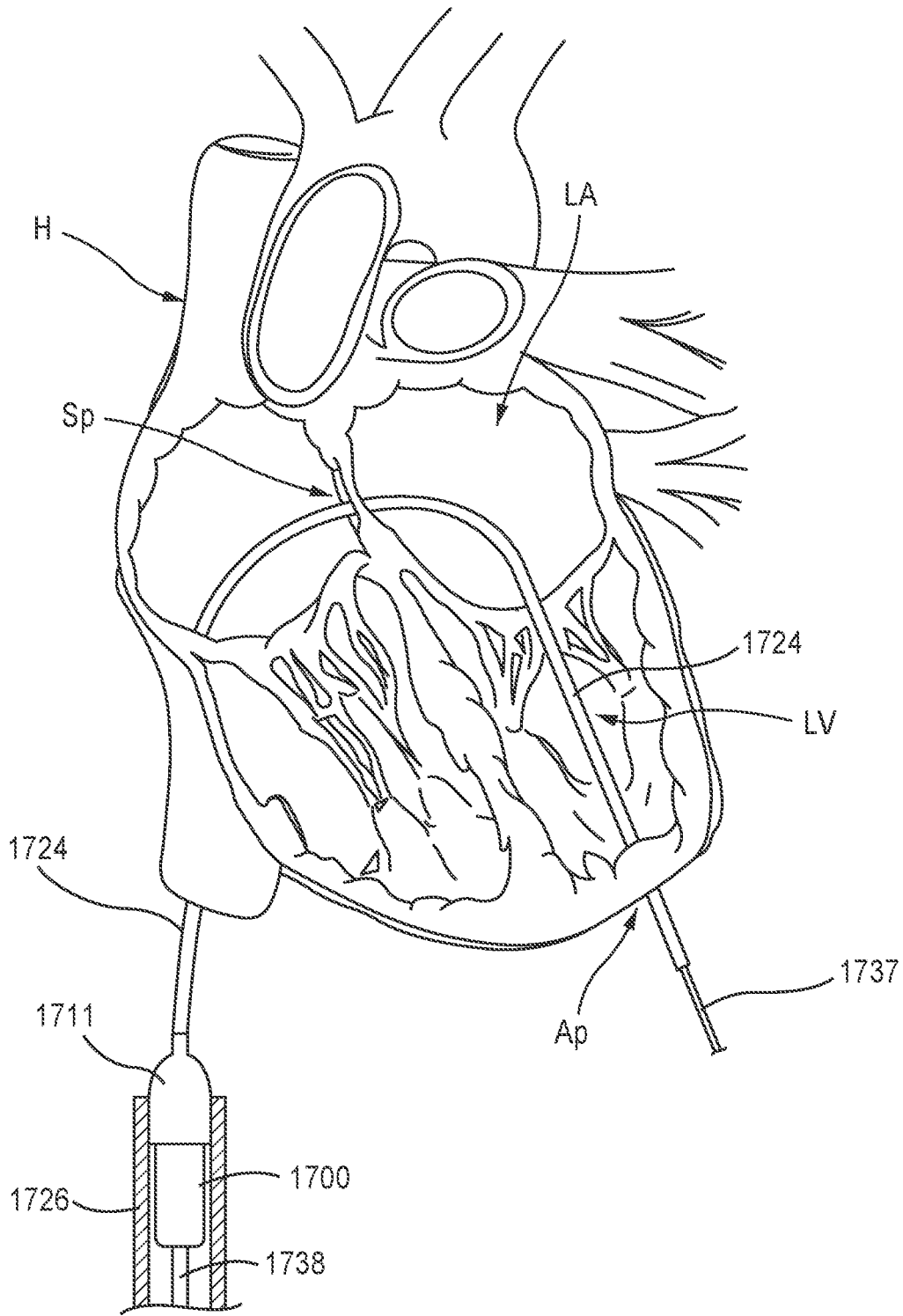

FIG. 67

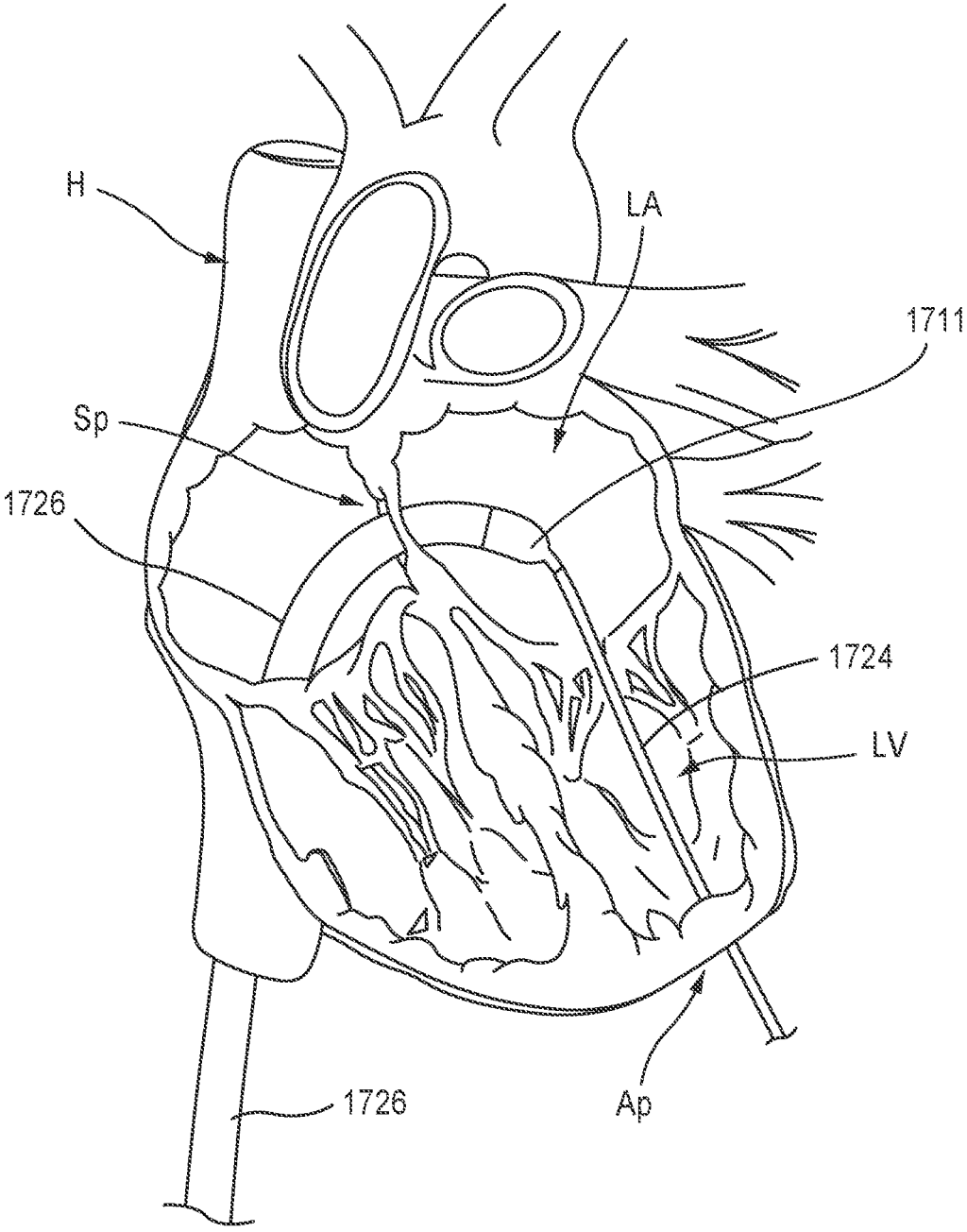

FIG. 68

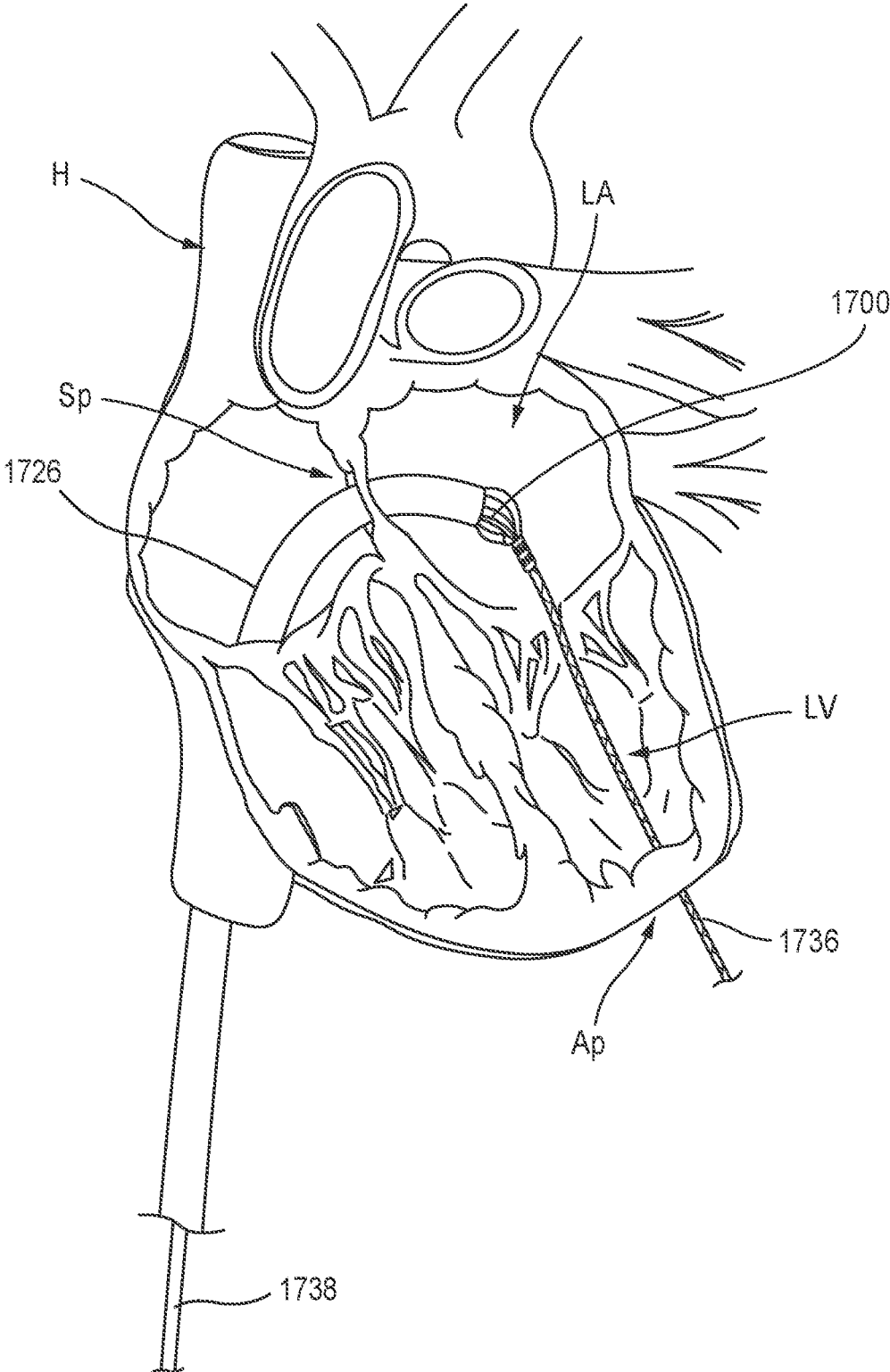

FIG. 69

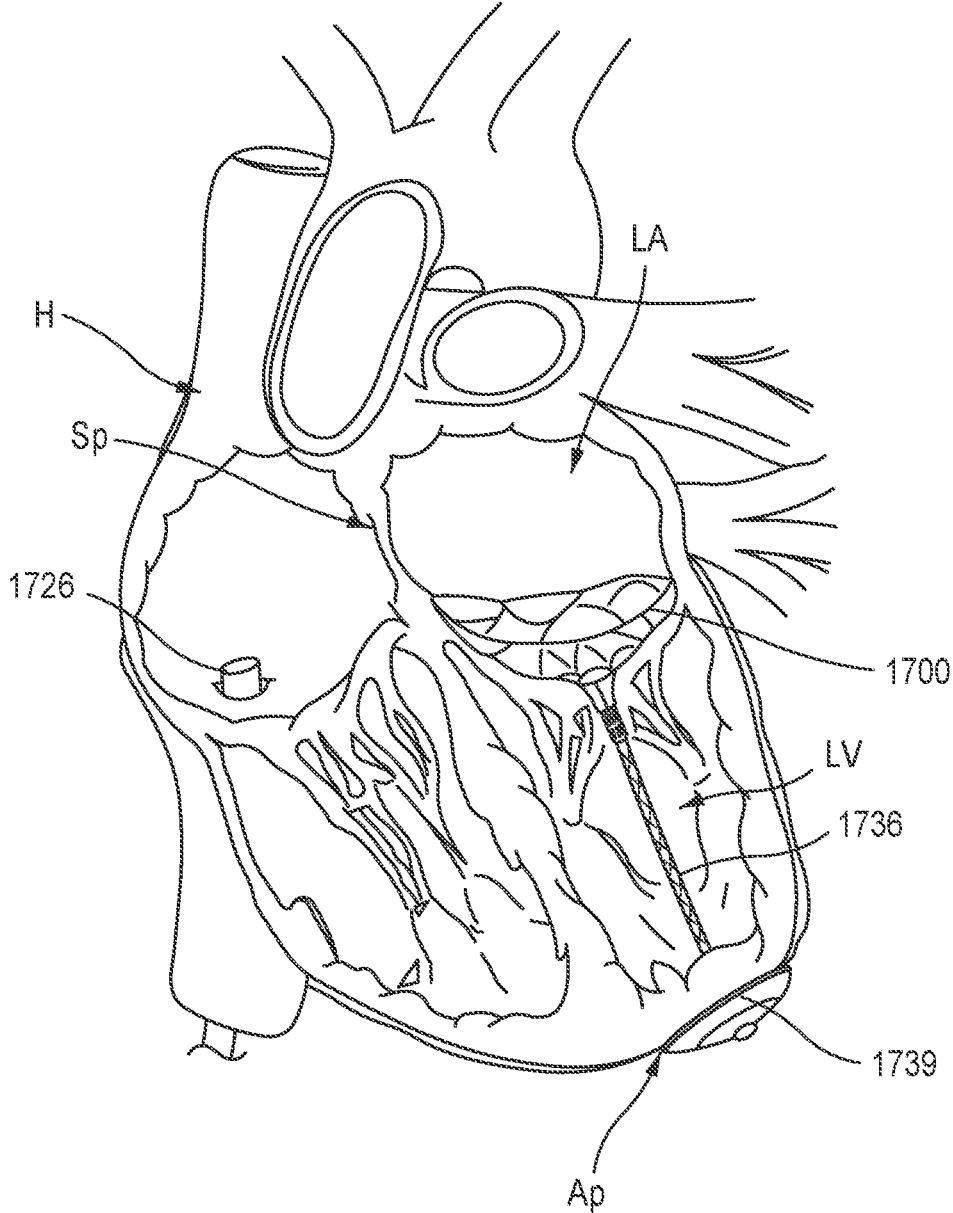

FIG. 70

**EXPANDABLE EPICARDIAL PADS AND
DEVICES AND METHODS FOR DELIVERY
OF SAME**

This application is a divisional of U.S. patent application 5
Ser. No. 15/654,374, filed Jul. 19, 2017, which is a continuation
of International PCT Application No. PCT/US2016/
016567, entitled “Expandable Epicardial Pads and Devices
and Methods for Delivery of Same,” filed Feb. 4, 2016,
which claims priority to and is a continuation-in-part of
International PCT Application No. PCT/US2015/014572,
entitled “Apparatus and Methods for Transfemoral Delivery
of Prosthetic Mitral Valve,” filed Feb. 5, 2015, which claims
priority to and the benefit of U.S. Provisional Patent Appli-
cation Ser. No. 61/935,899, entitled “Transfemoral Delivery
of Prosthetic Mitral Valve,” filed Feb. 5, 2014, and U.S.
Provisional Patent Application No. 62/100,548, entitled
“Apparatus and Methods for Transfemoral Delivery of Pros-
thetic Mitral Valve,” filed Jan. 7, 2015. The disclosure of 20
each of the above applications is incorporated herein by
reference in its entirety.

International PCT Application No. PCT/US2016/016567
also claims priority to and the benefit of U.S. Provisional
Patent Application No. 62/212,803, entitled “Dilator 25
Devices and Methods for Epicardial Pad Delivery,” filed
Sep. 1, 2015, the disclosure of which is incorporated herein
by reference in its entirety.

International PCT Application No. PCT/US2016/016567
is also related to International PCT Application No. PCT/
US2014/0049218, entitled “Epicardial Anchor Devices and
Methods,” filed Jul. 31, 2014, the disclosure of which is
incorporated herein by reference in its entirety.

BACKGROUND

Embodiments are described herein that relate to devices
and methods for delivery and deployment of prosthetic
valves and epicardial pads.

Prosthetic heart valves can pose particular challenges for
delivery and deployment within a heart. Valvular heart
disease, and specifically, aortic and mitral valve disease is a
significant health issue in the United States (US); annually
approximately 90,000 valve replacements are conducted in
the US. Traditional valve replacement surgery involving the
orthotopic replacement of a heart valve is considered an
“open heart” surgical procedure. Briefly, the procedure
necessitates surgical opening of the thorax, the initiation of
extra-corporeal circulation with a heart-lung machine, stop-
ping and opening the heart, excision and replacement of the
diseased valve, and re-starting of the heart. While valve
replacement surgery typically carries a 1-4% mortality risk
in otherwise healthy persons, a significantly higher morbidity
is associated to the procedure largely due to the necessity
for extra-corporeal circulation. Further, open heart surgery is
often poorly tolerated in elderly patients. Thus elimination
of the extra-corporeal component of the procedure could
result in reduction in morbidities and cost of valve replace-
ment therapies could be significantly reduced.

While replacement of the aortic valve in a transcatheter
manner is the subject of intense investigation, lesser atten-
tion has been focused on the mitral valve. This is in part
reflective of the greater level of complexity associated to the
native mitral valve apparatus, and thus, a greater level of
difficulty with regards to inserting and anchoring the

replacement prosthesis. A need exists for delivery devices
and methods for transcatheter mitral valve replacements.

SUMMARY

Devices and methods for use in the delivery and deploy-
ment of a prosthetic valve and an epicardial pad are
described herein. As described herein, in some embodi-
ments, a method includes delivering and deploying an
expandable tissue dilator device. The expandable tissue
dilator device can be used to dilate tissue or otherwise create
space near an apex of a heart. In some embodiments, after
a prosthetic mitral valve has been deployed within the heart
via a transfemoral, transapical or other suitable delivery
approach, a tether attached to the prosthetic valve can extend
outside the apex of the heart. The tissue dilator can be used
to dilate tissue or otherwise create space for delivery and/or
deployment of an epicardial pad device near the apex of the
heart to secure the tether and the prosthetic valve in a desired
position. In some embodiments, the epicardial pad can be an
expandable epicardial pad.

BRIEF DESCRIPTION OF THE FIGURES

FIGS. 1-6 are each a cross-sectional illustration of a heart
with devices used during various stages in a procedure to
transfemorally deliver and deploy a prosthetic mitral valve.

FIGS. 7-9 are front, bottom, and top views of a prosthetic
heart valve according to an embodiment.

FIG. 10 is an opened and flattened view of the inner frame
of the prosthetic heart valve of FIGS. 7-9, in an unexpanded
configuration.

FIGS. 11 and 12 are side and bottom views, respectively,
of the inner frame of FIG. 10 in an expanded configuration.

FIG. 13 is an opened and flattened view of the outer frame
of the valve of FIGS. 7-9, in an unexpanded configuration.

FIGS. 14 and 15 are side and top views, respectively, of
the outer frame of FIG. 13 in an expanded configuration.

FIGS. 16-18 are side, front, and top views of an assembly
of the inner frame of FIGS. 10-12 and the outer frame of
FIGS. 13-15.

FIG. 19 is a side perspective view of the assembly of the
inner frame of FIGS. 10-12 and the outer frame of FIGS.
13-15 shown in a biased expanded configuration.

FIG. 20 is a side perspective view of the assembly of FIG.
19 with the outer frame shown inverted.

FIG. 21 is a side view of the assembly of FIG. 20 shown
in a collapsed configuration within a lumen of a delivery
sheath.

FIG. 22 is a side view of the assembly of FIG. 21 shown
in a first partially deployed configuration.

FIG. 23 is a side view of the assembly of FIG. 21 shown
in a second partially deployed configuration.

FIG. 24 is a side view of the assembly of FIG. 21 shown
in a third partially deployed configuration in which the
inverted outer frame is substantially deployed outside of the
delivery sheath.

FIG. 25 is a side view of the assembly of FIG. 21 shown
in a fourth partially deployed configuration in which the
outer frame has reverted and assumed a biased expanded
configuration.

FIG. 26 is a side view illustrating a portion of a tether
coupled to a portion of a valve leader member, according to
an embodiment.

FIG. 27 is a side view of a prosthetic mitral valve in a
collapsed configuration within a lumen of a portion of a
delivery sheath and a balloon dilator device coupled to the
delivery sheath.

FIG. 28 is a cross-sectional illustration of a heart with the delivery sheath and balloon dilator device of FIG. 27 at a stage of a procedure to deliver and deploy the prosthetic mitral valve disposed within the delivery sheath.

FIG. 29 is a cross-sectional illustration of a heart with a portion of a delivery sheath shown after deploying a prosthetic mitral valve with the assistance of a wire assist structure, according to an embodiment.

FIG. 30 is a perspective view of the wire assist structure of FIG. 29 coupled to a portion of a prosthetic mitral valve, according to an embodiment.

FIG. 31 is a perspective view of an assist member coupled to a portion of a prosthetic mitral valve, according to an embodiment.

FIG. 32 is a flowchart illustrating a method of delivering a prosthetic mitral valve via a femoral vein, according to an embodiment.

FIG. 33 is a side view of a portion of an epicardial pad device, according to an embodiment, and shown in a collapsed configuration within a delivery sheath.

FIG. 34 is a side perspective view of the epicardial pad device of FIG. 33 shown in an expanded configuration.

FIG. 35 is a side perspective view of a portion of a heart illustrating purse-string sutures at an apex of the heart prior to securing an epicardial pad device thereto.

FIG. 36 is a side perspective view of the epicardial pad device of FIG. 33 shown in the expanded configuration.

FIG. 37 is a bottom perspective view of a portion of a heart illustrating with the epicardial pad device of FIG. 33 secured thereto.

FIG. 38 is an enlarged side perspective view and FIG. 39 is an enlarged bottom view of a portion A in FIG. 37 illustrating an integrated locking mechanism.

FIG. 40 is a side view of an epicardial pad device, according to another embodiment, and shown in a collapsed configuration.

FIG. 41 is a side perspective view of the epicardial pad device of FIG. 40 shown in an expanded configuration.

FIG. 42 is a side view of the epicardial device of FIG. 40 shown in the expanded configuration and being deployed near an apex of a heart.

FIG. 43 is a side view of an epicardial pad device, according to another embodiment, and shown in an expanded configuration being deployed near a heart.

FIG. 44 is a side view of the epicardial pad device of FIG. 43 shown in a collapsed configuration and deployed on the apex of the heart.

FIGS. 45 and 46 are each a side view of an epicardial pad device, according to another embodiment, and shown being deployed on an apex of a heart.

FIG. 47 is a bottom view of a heart with the epicardial pad of FIGS. 45 and 46 secured to the apex of the heart.

FIG. 48 is an illustration of a patient with a portion of a tether shown extended from within the heart of the patient to outside of the patient, according to an embodiment.

FIG. 49 is an illustration of the patient of FIG. 48 with an expandable tissue dilator device disposed within the patient, shown in a collapsed configuration near the patient's heart, and distal to a distal end of a delivery sheath.

FIG. 50 is an illustration of the expandable tissue dilator device of FIG. 49 in an expanded configuration and disposed within the patient near the patient's heart.

FIG. 51 is an illustration of a portion of an epicardial pad device in an expanded configuration extending from a delivery sheath and disposed near an apex region of the patient's heart.

FIG. 52 is an illustration of the epicardial pad device of FIG. 51 delivered and deployed at the apex region of the patient's heart.

FIG. 53 is a partial cross-sectional side view of a portion of an epicardial pad delivery device, according to an embodiment, in an undeployed configuration.

FIG. 54 is a partial cross-sectional side view of the epicardial pad delivery device of FIG. 53 during a stage of a procedure to deliver an epicardial pad device to the apex region of a patient's heart.

FIG. 55 is a side view illustration of the epicardial pad delivery device of FIG. 53 during another stage of a procedure to deliver an epicardial pad device to the apex region of a patient's heart.

FIG. 56 is a side view illustration of the epicardial pad delivery device of FIG. 53 during another stage of a procedure to deliver an epicardial pad device to the apex region of a patient's heart.

FIG. 57 is a side view illustration of the epicardial pad delivery device of FIG. 53 during another stage of a procedure to deliver an epicardial pad device to the apex region of a patient's heart.

FIG. 58 is a side view illustration of a portion of an epicardial pad assembly and an epicardial pad delivery device, according to an embodiment, during a stage of a procedure to deliver the epicardial pad assembly to the apex region of a patient's heart.

FIG. 59 is a side view illustration of the epicardial pad assembly and the epicardial pad delivery device of FIG. 58 during another stage of a procedure to deliver the epicardial pad assembly to the apex region of a patient's heart.

FIG. 60 is a side view illustration of the epicardial pad assembly and the epicardial pad delivery device of FIG. 58 during another stage of a procedure to deliver the epicardial pad assembly to the apex region of a patient's heart.

FIG. 61 is an illustration of a cutter assembly, according to an embodiment, used during a stage of a procedure to deliver the epicardial pad assembly of FIGS. 58-60 to the apex region of a patient's heart.

FIG. 62 is a side view illustration shown partially in cross-section of an epicardial pad assembly and an epicardial pad delivery device, according to an embodiment, during a stage of a procedure to deliver the epicardial pad assembly to the apex region of a patient's heart.

FIG. 63 is a side view illustration of the epicardial pad assembly of FIG. 62 in an expanded configuration.

FIG. 64 is a side view illustration of the epicardial pad assembly of FIG. 62 in a collapsed configuration.

FIGS. 65-70 are each a cross-sectional illustration of a heart with devices used during various stages in a procedure to transfemorally deliver and deploy a prosthetic mitral valve.

DETAILED DESCRIPTION

Devices and methods for use in the delivery and deployment of prosthetic mitral valves and epicardial pads are described herein. As described herein, in some embodiments, a method includes delivering and deploying an expandable tissue dilator device. The expandable tissue dilator device can be used to dilate tissue or otherwise create space near an apex region of a heart. In some embodiments, after a prosthetic mitral valve has been deployed within the heart via a transcatheter or other suitable delivery approach, a tether attached to the prosthetic valve can extend outside the apex of the heart. The tissue dilator device can be used to dilate tissue or otherwise create space for delivery and/or

deployment of an epicardial pad device at the apex region of the heart to secure the tether and the prosthetic valve in a desired position.

The prosthetic valve can be delivered to within a patient's heart using a variety of different delivery approaches for delivering a prosthetic heart valve (e.g., prosthetic mitral valve). For example, the prosthetic valves described herein can be delivered using a transfemoral delivery approach as described in International Application No. PCT/US15/14572 (the '572 PCT application) incorporated by reference above, or via a transatrial approach, such as described in U.S. Provisional Patent Application Ser. No. 62/220,704, entitled "Apparatus and Methods for Transatrial Delivery of Prosthetic Mitral Valve," filed Sep. 18, 2015 ("the '704 provisional application"), which is incorporated herein by reference in its entirety. In another example, a prosthetic mitral valve as described herein can be delivered via a transjugular approach, via the right atrium and through the atrial septum and into the left atrium. The prosthetic valves described herein can also be delivered apically if desired.

In some embodiments, an apparatus includes an epicardial pad configured to engage an outside surface of a heart to secure a prosthetic heart valve in position within the heart. The prosthetic heart valve has a tether extending therefrom and outside the heart when the prosthetic heart valve is disposed within the heart. The epicardial pad defines a lumen configured to receive the tether therethrough. The epicardial pad is movable between a first configuration in which the epicardial pad has a first outer perimeter and is configured to be disposed within a lumen of a delivery sheath and a second configuration in which the epicardial pad has a second outer perimeter greater than the first outer perimeter. The epicardial pad can be disposed against the outside surface of the heart when in the second configuration to secure the prosthetic valve and tether in a desired position within the heart.

In some embodiments, an apparatus includes a delivery sheath that defines a first lumen and a dilator device that defines a second lumen and is movably disposed within the first lumen of the delivery sheath. The dilator device includes an elongate member and an expandable member disposed at a distal end of the elongate member. The expandable member has a collapsed configuration and an expanded configuration. The dilator device is in the collapsed configuration when disposed within the first lumen. An epicardial pad having a collapsed configuration and an expanded configuration is configured to be disposed within the second lumen when in the collapsed configuration. The epicardial pad is configured to be disposed against an outside surface of a heart when in the expanded configuration. The dilator member of the dilator device is configured to dilate tissue associated with the outside surface of the heart when moved from its collapsed configuration to its expanded configuration such that a space is formed in which the epicardial pad can be disposed.

In some embodiments, a method includes disposing a distal end portion of a delivery sheath outside a surface of a heart near an apex of the heart. The delivery sheath has a dilator device movably disposed within a lumen of the delivery sheath. The dilator device includes an elongate member and a dilator member disposed at a distal end portion of the elongate member, and is movable from a collapsed configuration when disposed within the lumen of the delivery sheath and an expanded configuration. After disposing the delivery sheath outside a surface of the heart, the dilator member of the dilator device is disposed outside a distal end of the delivery sheath, and is moved to the

expanded configuration such that tissue associated with the surface of the heart is dilated from pressure exerted on the tissue by the dilator member and a space is formed to receive an epicardial pad device.

In some embodiments, a method includes disposing a distal end portion of a delivery sheath outside a surface of a heart near an apex of the heart. The delivery sheath has an epicardial pad disposed within a lumen of the delivery sheath. The epicardial pad has a collapsed configuration when disposed within the lumen of the delivery sheath and an expanded configuration. The epicardial pad defines an opening and has a tether extending through the opening. The tether is coupled to a prosthetic heart valve implanted within the heart. The epicardial pad is disposed outside a distal end of the delivery sheath and outside the surface of the heart near the apex of the heart. The epicardial pad is secured in the expanded configuration to the outside surface of the heart to secure the prosthetic heart valve and the tether in a desired position.

FIGS. 1-6 illustrate one example method of delivering a prosthetic mitral valve **200** (shown in FIGS. 3-6) to a left atrium LA of a heart H via introduction through a femoral vein. As shown in FIG. 1, a procedural catheter **222** is inserted through an apical puncture (e.g., a 5F apical puncture) in a ventricular wall at the apex Ap of the heart H. A leader tube **224** is inserted through a lumen (not shown) of the procedural catheter **222** and extended through the left ventricle LV, through a mitral valve gap and into the left atrium LA. A delivery sheath **226** is introduced through a femoral vein puncture and extended through the inferior vena cava, into the right atrium, and then through a transseptal puncture of the septum Sp of the heart H, and into the left atrium LA of the heart H. A snare device **228** is movably disposed within the delivery sheath **226** and used to grab or snare a distal end portion of the leader tube **224**, as shown in FIG. 1. The snare device **228** can be used to pull the leader tube **224** through the delivery sheath **226** such that the distal end portion of the leader tube **224** extends outside the femoral vein and a proximal end of the leader tube **224** is disposed through the ventricular wall at the apex Ap of the heart H, as shown in FIG. 2. The leader tube **224** allows for back-loading of the prosthetic mitral valve **200** starting in the femoral vein and exiting the heart H at the apex Ap. Although not shown in FIGS. 1 and 2, the procedural catheter **224** is disposed outside the patient's body, the distal end of the leader tube **224** extends outside the femoral vein and outside the patient's body, and the proximal end of the leader tube **224** extends outside the apex Ap and outside the patient's body. Although the above described snare process describes delivering the leader tube **224** to the left atrium of the heart and then snaring the leader tube **224** using the snare device **228**, in alternative embodiments, the leader tube **224** can be delivered to the left ventricle LV and the snare device **228** and delivery sheath **226** can be inserted through the mitral annulus and into the left ventricle LV to grab or snare the leader tube **224** as described above.

After the leader tube **224** has been extended between the apex Ap and the access site to the femoral vein, a valve leader member **234** attached to the prosthetic mitral valve **200** (also referred to as "valve") can be inserted into the leader tube **224** at the femoral end of the leader tube **224** and extended through the leader tube **224** until the valve leader member **234** exits the leader tube at the apex end of the leader tube **224**. After the valve leader member **234** is inserted and extended outside the apex Ap, the leader tube **224** can be removed from the patient. For example, the leader tube **224** can be pulled out through the apex puncture

site, or through the femoral vein puncture site. Thus, only the valve leader member **234** remains disposed within the body, as shown in FIG. 3.

The valve leader member **234** can have a tapered distal end **235** to aid in the insertion and maneuvering of the valve leader member **234** through the leader tube **224**. The valve leader member **234** is attached at a proximal end portion **237** to a tether line **236** (also referred to herein as “tether”), which is attached to the valve **200**. FIG. 26 illustrates an enlarged view of the attachment of the proximal end portion **237** to tether **236**. The tether **236** can be formed, for example, as a braided rope or cord as shown, for example, in FIG. 26.

As shown in FIG. 3, the valve **200** is partially disposed within a lumen of the delivery sheath **226**. Although the delivery sheath **226** is used to deliver both the snare device **228** and the valve **200**, in other embodiments, a different delivery sheath can be used to deliver the snare device **228** than is used to deliver the valve **200**. As shown in FIG. 3, prior to inserting the valve leader member **234** into the leader tube **224**, the procedural catheter **222** can be removed. Alternatively, the procedural catheter **222** can be removed after inserting the valve leader member **234**.

Also as shown in FIG. 3, in this embodiment, a portion of the valve **200** is allowed to partially deploy outside a distal end of the delivery sheath **226**. The partially deployed portion of the valve **200** can be used as a lead-in to the delivery sheath **226** as the valve **200** is inserted through the femoral vein. For example, the valve **200** can be formed with a shape-memory material (as described in more detail below) and can have a biased undeformed shape and can be manipulated and/or deformed (e.g., compressed and/or expanded) and, when released, return to its original undeformed shape. In some embodiments, the valve **200** can have a biased expanded or undeformed configuration when deployed within a heart, and can be moved to a collapsed or deformed configuration when placed within the lumen of the delivery sheath **226** for delivery through the femoral vein. The valve can be, for example, a valve constructed the same as or similar to, and function in the same or similar manner as, the prosthetic heart valve **500**, described in detail below.

After the valve leader member **234** has been placed in position between the femoral puncture site and the apical puncture site, as described above, the delivery sheath **226** with the valve **200** can be inserted through the femoral puncture site and moved through the femoral vein, through the inferior vena cava, into the right atrium, and then through the septum Sp until a distal end portion of the delivery sheath **226** (with the valve **200**) is disposed within the left atrium LA, as shown in FIG. 4. As shown in FIG. 4, the tether **236** extends from the valve **200** through the apical puncture and outside the patient’s body. As the delivery sheath **226** is advanced, the tether **236** can optionally be pulled at the apex end to help move the delivery sheath **226**, with the valve **200** disposed therein, through the femoral vein, through the septal puncture and into the left atrium LA. The valve **200** can then be fully deployed within the left atrium LA (see, e.g., FIG. 5) by pulling the apex end portion of the tether **236** until the valve **200** is pulled out of the lumen of the delivery sheath **226** and disposed within the left atrium LA. Alternatively, pusher device **238** (see, e.g., FIG. 4) can be inserted within the delivery sheath **226** and used to push the valve **200** outside a distal end of the delivery sheath **226**. In yet other embodiments, the pusher device **238** can be used to push the valve **200** while the tether **236** is pulled. In other words, the valve **200** can be deployed by pushing the valve **200** with the pusher device **238**, by pulling

the valve **200** with the tether **236**, or both. The pusher **238** can also be used to aid in positioning the valve **200** in a desired radial orientation within the left atrium LA. For example, the pusher device **238** can define an internal lumen (not shown) that can be placed over an inner frame portion of the valve **200** to hold the inner frame portion in a small diameter, which can help enable the valve **200** to be positioned in a desired radial orientation and be seated within the annulus of the mitral valve. Further examples of such a valve assist device are described below with reference to FIGS. 29-31.

As shown in FIGS. 5 and 6, as the valve **200** is deployed within the left atrium LA, the valve **200** is allowed to assume its biased expanded or deployed configuration. The delivery sheath **226** can then be removed from the patient and the valve **200** can be positioned and tensioned using the tether **236** to obtain the desired or optimal location in the native mitral annulus and minimize perivalvular leaks. An epicardial pad device **239** can be used to secure the tether **236** and valve **200** in position within the mitral annulus as shown in FIG. 6. For example, an epicardial pad device as described in International Patent Application No. PCT/US14/49218 (“the ’218 PCT application”), the disclosure of which is incorporated herein by reference in its entirety, can be used. In some embodiments, an expandable epicardial pad can be used to secure the tether and valve in position. Example embodiments of expandable pads that can be used are described herein with reference to FIGS. 33-47. Such a pad can be smaller in size such that the pad can be delivered to the heart via a small incision and small catheter or delivery sheath. In some embodiments, a positioning device (not shown) can be used to help position the valve **200** and deploy the epicardial pad device. For example, a positioning device as described in the ’218 PCT application incorporated by reference above, or devices described in International Patent Application No. PCT/US14/61046, the disclosure of which is incorporated herein by reference in its entirety, can be used. In some embodiments, rather than securing the prosthetic mitral valve with a tether and epicardial pad, the prosthetic mitral valve can be secured with clips or other coupling methods to a portion(s) of the mitral valve apparatus and/or the ventricular wall of the heart. For example, such coupling methods are described in International Patent Application No. PCT/US14/58826 (“the ’826 PCT application”), the disclosure of which is incorporated herein by reference in its entirety.

FIGS. 7-9 illustrate an embodiment of a prosthetic heart valve that can be delivered and deployed within a left atrium of a heart using a transfemoral delivery approach as described above. FIGS. 7-9 are front, bottom, and top views, respectively, of a prosthetic heart valve **500** according to an embodiment. Prosthetic heart valve **500** (also referred to herein as “valve”) is designed to replace a damaged or diseased native heart valve such as a mitral valve. Valve **500** includes an outer frame assembly **510** and an inner valve assembly **540** coupled to the outer frame assembly **510**.

As shown, outer frame assembly **510** includes an outer frame **520**, covered on all or a portion of its outer face with an outer covering **530**, and covered on all or a portion of its inner face by an inner covering **532**. Outer frame **520** can provide several functions for prosthetic heart valve **500**, including serving as the primary structure, as an anchoring mechanism and/or an attachment point for a separate anchoring mechanism to anchor the valve to the native heart valve apparatus, a support to carry inner valve assembly

540, and/or a seal to inhibit paravalvular leakage between prosthetic heart valve 500 and the native heart valve apparatus.

Outer frame 520 is configured to be manipulated and/or deformed (e.g., compressed and/or expanded) and, when released, return to its original (undeformed) shape. To achieve this, outer frame 520 can be formed of materials, such as metals or plastics, that have shape memory properties. With regards to metals, Nitinol has been found to be especially useful since it can be processed to be austenitic, martensitic or super elastic. Other shape memory alloys, such as Cu—Zn—Al—Ni alloys, and Cu—Al—Ni alloys, may also be used.

As best shown in FIG. 7, outer frame assembly 510 has an upper end (e.g., at the atrium portion 516), a lower end (e.g., at the ventricle portion 512), and a medial portion (e.g., at the annulus portion 514) therebetween. The medial portion of the outer frame assembly 510 has a perimeter that is configured (e.g., sized, shaped) to fit into an annulus of a native atrioventricular valve. The upper end of the outer frame assembly 510 has a perimeter that is larger than the perimeter of the medial portion. In some embodiments, the perimeter of the upper end of the outer frame assembly 510 has a perimeter that is substantially larger than the perimeter of the medial portion. As shown best in FIG. 9, the upper end and the medial portion of the outer frame assembly 510 has a D-shaped cross-section. In this manner, the outer frame assembly 510 promotes a suitable fit into the annulus of the native atrioventricular valve.

Inner valve assembly 540 includes an inner frame 550, an outer covering 560, and leaflets 570. As shown, the inner valve assembly 540 includes an upper portion having a periphery formed with multiple arches. The inner frame 550 includes six axial posts or frame members that support outer covering 560 and leaflets 570. Leaflets 570 are attached along three of the posts, shown as commissure posts 552 (best illustrated in FIG. 8), and outer covering 560 is attached to the other three posts, 554 (best illustrated in FIG. 8), and optionally to commissure posts 552. Each of outer covering 560 and leaflets 570 are formed of approximately rectangular sheets of material, which are joined together at their upper, or atrium end. The lower, ventricle end of outer covering 560 may be joined to inner covering 532 of outer frame assembly 510, and the lower, ventricle end of leaflets 570 may form free edges 575, though coupled to the lower ends of commissure posts 552.

Although inner valve assembly 540 is shown as having three leaflets, in other embodiments, an inner valve assembly can include any suitable number of leaflets. The leaflets 570 are movable between an open configuration and a closed configuration in which the leaflets 570 coapt, or meet in a sealing abutment.

Outer covering 530 of the outer frame assembly 510 and inner covering 532 of outer frame assembly 510, outer covering 560 of the inner valve assembly 540 and leaflets 570 of the inner valve assembly 540 may be formed of any suitable material, or combination of materials, such as those discussed above. In this embodiment, the inner covering 532 of the outer frame assembly 510, the outer covering 560 of the inner valve assembly 540, and the leaflets 570 of the inner valve assembly 540 are formed, at least in part, of porcine pericardium. Moreover, in this embodiment, the outer covering 530 of the outer frame assembly 510 is formed, at least in part, of polyester.

Inner frame 550 is shown in more detail in FIGS. 10-12. Specifically, FIGS. 10-12 show inner frame 550 in an undeformed, initial state (FIG. 10), a side view of the inner

frame 550 in a deployed configuration (FIG. 11), and a bottom view of the inner frame 550 in a deployed configuration (FIG. 12), respectively, according to an embodiment.

In this embodiment, inner frame 550 is formed from a laser-cut tube of Nitinol®. Inner frame 550 is illustrated in FIG. 10 in an undeformed, initial state, i.e. as laser-cut, but cut and unrolled into a flat sheet for ease of illustration. Inner frame 550 can be divided into four portions, corresponding to functionally different portions of the inner frame 550 in final form: atrial portion 541, body portion 542, strut portion 543, and tether clamp or connecting portion 544. Strut portion 543 includes six struts, such as strut 543A, which connect body portion 542 to tether clamp portion 544.

Connecting portion 544 includes longitudinal extensions of the struts, connected circumferentially by pairs of opposed, slightly V-shaped connecting members (or “micro-Vs”). Connecting portion 544 is configured to be radially collapsed by application of a compressive force, which causes the micro-Vs to become more deeply V-shaped, with the vertices moving closer together longitudinally and the open ends of the V shapes moving closer together circumferentially. Thus, connecting portion 544 can be configured to compressively clamp or grip one end of a tether, either connecting directly onto a tether line (e.g. braided filament line) or onto an intermediate structure, such as a polymer or metal piece that is in turn firmly fixed to the tether line.

In contrast to connecting portion 544, atrial portion 541 and body portion 542 are configured to be expanded radially. Strut portion 543 forms a longitudinal connection, and radial transition, between the expanded body portion and the compressed connecting portion 544.

Body portion 542 includes six longitudinal posts, such as post 542A. The posts can be used to attach leaflets 570 to inner frame 540, and/or can be used to attach inner assembly 540 to outer assembly 510, such as by connecting inner frame 550 to outer frame 520. In the illustrated embodiment, the posts include openings through which connecting members (such as suture filaments and/or wires) can be passed to couple the posts to other structures.

Inner frame 550 is shown in a fully deformed, i.e. the final, deployed configuration, in side view and bottom view in FIGS. 11 and 12, respectively.

Outer frame 520 of valve 500 is shown in more detail in FIGS. 13-15. In this embodiment, outer frame 520 is also formed from a laser-cut tube of Nitinol®. Outer frame 520 is illustrated in FIG. 13 in an undeformed, initial state, i.e. as laser-cut, but cut and unrolled into a flat sheet for ease of illustration. Outer frame 520 can be divided into a coupling portion 571, a body portion 572, and a cuff portion 573, as shown in FIG. 13. Coupling portion 571 includes multiple openings or apertures, such as 571A, by which outer frame 520 can be coupled to inner frame 550, as discussed in more detail below.

Outer frame 520 is shown in a fully deformed, i.e. the final, deployed configuration, in side view and top view in FIGS. 14 and 15, respectively. As best seen in FIG. 15, the lower end of coupling portion 571 forms a roughly circular opening (identified by “0” in FIG. 15). The diameter of this opening preferably corresponds approximately to the diameter of body portion 542 of inner frame 550, to facilitate coupling of the two components of valve 500.

Outer frame 520 and inner frame 550 are shown coupled together in FIGS. 16-18, in front, side, and top views, respectively. The two frames collectively form a structural support for a prosthetic valve such as valve 500. The frames support the valve leaflet structure (e.g., leaflets 570) in the desired relationship to the native valve annulus, support the

coverings (e.g., outer covering 530, inner covering 532, outer covering 560) for the two frames to provide a barrier to blood leakage between the atrium and ventricle, and couple to the tether (e.g., tether assembly 590) (by the inner frame 550) to aid in holding the prosthetic valve in place in the native valve annulus by the tether connection to the ventricle wall. The outer frame 520 and the inner frame 550 are connected at six coupling points (representative points are identified as "C"). In this embodiment, the coupling points are implemented with a mechanical fastener, such as a short length of wire, passed through an aperture (such as aperture 571A) in coupling portion 571 of outer frame 520 and corresponding openings in longitudinal posts (such as post 542A) in body portion 542 of inner frame 550. Inner frame 550 is thus disposed within the outer frame 520 and securely coupled to it.

FIGS. 19-25 illustrate a method of reconfiguring a prosthetic heart valve 300 (e.g., prosthetic mitral valve) prior to inserting the prosthetic heart valve 300 into a delivery sheath 326 (see, e.g., FIGS. 21-25) for delivery into the heart via the femoral vein. The prosthetic heart valve 300 (also referred to herein as "valve") can be constructed the same as or similar to, and function the same as or similar to the valve 500 described above. Thus, some details regarding the valve 300 are not described below. It should be understood that for features and functions not specifically discussed, those features and functions can be the same as or similar to the valve 500.

As shown in FIG. 19, the valve 300 has an outer frame 320 and an inner frame 350. As discussed above for valves 200 and 500, the outer frame 320 and the inner frame 350 of valve 300 can each be formed with a shape-memory material and have a biased expanded or deployed configuration. The outer frame 320 and the inner frame 350 can be moved to a collapsed or undeployed configuration for delivery of the valve 300 to the heart. In this example method of preparing the valve 300 for delivery to the heart, the outer frame 320 of the valve 300 is first disposed in a prolapsed or inverted configuration as shown in FIG. 20. Specifically, the elastic or superelastic structure of outer frame 320 of valve 300 allows the outer frame 320 to be disposed in the prolapsed or inverted configuration prior to the valve 300 being inserted into the lumen of the delivery sheath 326. As shown in FIG. 20, to dispose the outer frame 320 in the inverted configuration, the outer frame 320 is folded or inverted distally such that the outer frame 320 is pointed away from the inner frame 350. In this inverted configuration, the overall outer perimeter or outer diameter of the valve 300 is reduced and the overall length is increased. For example, the diameter D1 shown in FIG. 19 is greater than the diameter D2 shown in FIG. 20, and the length L1 in FIG. 19 is less than the length L2 in FIG. 20. With the outer frame 320 in the inverted configuration, the valve 300 can be placed within a lumen of a delivery sheath 326 as shown in FIG. 21 for delivery of the valve 300 to the left atrium of the heart. By disposing the outer frame 320 in the inverted configuration, the valve 300 can be collapsed into a smaller overall diameter, i.e. placed in a smaller diameter delivery sheath, than would be possible if the valve 300 in the configuration shown in FIG. 19 were collapsed radially. This is because in the configuration shown in FIG. 19, the two frames are concentric, and thus the outer frame 320 must be collapsed around the inner frame 350, whereas in the configuration shown in FIG. 20, the two frames are coaxial but not concentric, such that the outer frame 320 can be collapsed without needing to accommodate the inner frame 350 inside it.

The procedure to deliver the valve 300 to the heart can be the same as or similar to the procedure described with reference to FIGS. 1-6. In this embodiment, the valve 300 is not partially deployed outside of the lumen of the delivery sheath 326 prior to being inserted into a femoral puncture, through the femoral vein, through the inferior vena cava, into the right atrium, through the septum Sp and into the left atrium LA of the heart. With the distal end portion of the delivery sheath 326 disposed within the left atrium of the heart, the valve 300 can be deployed outside of the delivery sheath 326. For example, although not shown, a tether such as tether 236 described above for valve 200 can be attached to the valve 300 and used to pull the valve 300 out of the lumen of the delivery sheath 326. Alternatively, or in addition to, a pusher device (not shown) can be used to deploy the valve 300. Thus, as described above for valve 200, the valve 300 can be deployed by pushing with the pusher device, pulling with the tether, or both.

As the valve 300 exits the lumen of the delivery sheath 326, the outer frame assembly 310 exits first in its inverted configuration as shown in the progression of FIGS. 22-24. After the outer frame assembly 310 is fully outside of the lumen of the delivery sheath 326, the outer frame 320 can revert to its expanded or deployed configuration as shown in FIG. 25. In some embodiments, the pusher device and/or the tether can be used to aid in the reversion of the outer frame assembly 310. The valve 300 can continue to be deployed until the inner frame 350 is fully deployed within the left atrium and the valve 300 is in the expanded or deployed configuration (as shown in FIG. 19).

FIGS. 27 and 28 illustrate an optional balloon dilator device that can be used during a procedure for transfemoral delivery of a prosthetic heart valve to the heart. FIG. 27 illustrates a valve 400 disposed within a lumen of a delivery sheath 426. The valve 400 can be constructed the same as or similar to, and function the same as or similar to, the valves 200, 500 and 300 described above. For example, the valve 400 can include an outer frame 420 and an inner frame 450 as described above for previous embodiments. A tether 436 can be coupled to the valve 400 and a valve leader member 434 (see FIG. 28) can be coupled to the tether 436.

In this embodiment, to deliver the valve 400, a leader tube (not shown) can be inserted through an apical puncture and extended through the heart and out through a femoral vein access site. A valve leader member 434 coupled to a tether 436 can be inserted through the femoral end of the leader tube and extended out the apical end of the leader tube, as described above with respect to FIGS. 1-6. The valve 400 can be loaded into the distal end of a lumen of a delivery sheath 426 either before or after the tether 436 and valve leader member 434 are looped through the patient. A balloon dilator device 445 can then be advanced along the valve leader member 434 from the apical end, through the heart, through the femoral vein and out the femoral access site.

The balloon dilator device 445 includes a balloon member 446 that can be disposed at least partially within the distal end portion of the lumen of the delivery device 426, and distal of the valve 400, as shown in FIG. 27. The balloon dilator device 445 also includes an elongate member 447 coupled to the balloon member 446 and that defines an inflation lumen in fluid communication with an interior of the balloon member 446. The elongate member 447 can be coupled to a source of an inflation medium (not shown) configured to supply the inflation medium to the balloon member 446. With the balloon dilator device 445 coupled to the delivery sheath 426 as shown in FIG. 27, the balloon member 446 can be inflated. The delivery sheath 426 can

then be inserted through the femoral access site and advanced through the femoral vein, through the inferior vena cava, into the right atrium, through the septum Sp and into the left atrium LA as shown in FIG. 28. The balloon member 446 provides a smooth surface to aid in maneuvering the delivery sheath 426 through the femoral vein and the septum and into the heart. With the distal end portion of the delivery sheath 426 disposed within the left atrium LA, the balloon member 446 can be deflated and removed through the apical access site. The valve 400 can then be deployed and positioned within the mitral annulus as described above for FIGS. 1-6. For example, a pusher device 438 (see FIG. 27) can be used to push the valve 400 out of the lumen of the delivery sheath 426 and/or the tether 436 coupled to the valve 400 can be pulled.

FIGS. 29 and 30 illustrate an optional wire assist structure that can be used during a procedure to deliver a prosthetic heart valve transfemorally as described above for previous embodiments. A wire assist structure 649 can be releasably coupled to a valve 600 as shown in FIG. 29. The valve 600 can be constructed the same as or similar to, and function the same as or similar to, the valves described above for previous embodiments. For example, the valve 600 can include an outer frame 620 and an inner frame 650. The wire assist structure 649 can be releasably coupled to the inner frame 650 as best shown in FIG. 30. For example, releasable connectors (not shown) can be used to couple the wire assist structure 649 to the inner frame 650.

In use, the wire assist structure 649 can be movably disposed within a delivery sheath 626 used to deliver the valve 600 to the heart. The wire assist structure 649 can hold the inner frame 650 and allow for positioning control of the valve 600 (i.e., clocking and advancement) while the outer frame 650 of the valve 600 is fully expanded, which allows the valve 600 to be functioning during the positioning phase. When the valve 600 is in the desired final position, the wire assist structure 649 can be released from the inner frame 650 and removed with the delivery sheath 626.

FIG. 31 illustrates another optional assist member that can be used during a procedure to deliver a prosthetic heart valve transfemorally. An assist member 748 can be in the form of a tubular member defining a lumen with a diameter sized to receive at least a portion of the inner frame 750 of a valve 700. The valve 700 can be constructed the same as or similar to, and function the same as or similar to, the valves described above for previous embodiments. For example, the valve 700 can include an outer frame (not shown) and the inner frame 750 as described above for previous embodiments.

In use, the assist member 748 can be movably disposed within a delivery sheath (not shown) used to deliver the valve 700 and be disposed over at least a portion of the inner valve assembly 740. As with the wire assist structure 649, the assist member 748 can hold the inner frame 750 in a small compact configuration and allow for positioning control of the valve 700 (i.e., clocking and advancement) while the outer frame of the valve 700 is being expanded. This can in some cases allow the valve 700 to be functioning (or at least partially functioning) during the positioning phase of the valve 700. With the inner frame 750 held in a compact or small diameter form factor, the valve 700 can be more easily positioned to help seal the annulus with the outer frame (not shown) of the valve 700. When the valve 700 is in the desired final position, the assist member 748 can be removed.

FIG. 32 is a flowchart illustrating a method of deploying a prosthetic mitral valve to a heart using a transfemoral

delivery approach. The method includes at 880, inserting a leader tube through an access site on the skin of the patient, through an access puncture site on the apex of the heart, and positioning a distal end portion of the leader tube in the left atrium of the heart. At 881, inserting a delivery sheath with a snare device coupled thereto through an access site into the femoral vein and into the left atrium of the heart. At 882, the leader tube is captured with the snare device, and pulled through the femoral vein such that the leader tube extends between the apex of the heart and the entry to the femoral vein. At 883, an outer frame of a prosthetic mitral valve is disposed in an inverted configuration when the mitral valve is in a biased expanded configuration. For example, the prosthetic mitral valve can be formed with a shape-memory material and have a biased expanded configuration.

At 884, after inverting the outer frame, the prosthetic mitral valve is inserted into a lumen of a delivery sheath such that the prosthetic mitral valve is moved to a collapsed configuration. The delivery sheath can be the same delivery sheath as used with the snare device or a different delivery sheath. At 885, a valve leader member is inserted to the leader tube at the femoral end of the leader tube, and moved through the leader tube until the valve leader member exits the leader tube outside of the apex of the heart. A proximal end of the valve leader member is coupled to a tether line that in turn is coupled to the prosthetic mitral valve and disposed within the delivery sheath. At 886, the delivery sheath is inserted into the femoral vein and moved through the femoral vein and through a septum of a heart until a distal end portion of the delivery sheath is disposed in the left atrium of the heart. At 887, the prosthetic mitral valve is moved distally out of the delivery sheath such that the inverted outer frame of the prosthetic mitral valve reverts, and the prosthetic mitral valve assumes its biased expanded configuration. At 888, the prosthetic mitral valve is positioned within a mitral annulus of the heart and optionally an epicardial pad device can be secured to the apex of the heart to maintain the prosthetic mitral valve in the desired position (e.g., orientation) within the mitral annulus. In some embodiments, rather than securing the prosthetic mitral valve with a tether and epicardial pad, the prosthetic mitral valve can be secured with clips or other coupling methods to a portion(s) of the ventricular wall of the heart.

FIGS. 33-37 illustrate an embodiment of an expandable epicardial pad device that can be used to secure a tether attached to a prosthetic mitral valve to the heart, for example, at the apex of the heart. An epicardial pad device 939 (also referred to herein as "epicardial pad" or "pad") can be used, for example, during a procedure to deliver a prosthetic heart valve as described herein. The epicardial pad 939 can be formed with a small profile such that the epicardial pad 939 can be delivered to the exterior of the heart via a small incision and a small diameter delivery catheter or sheath 963 (see FIGS. 33 and 34). In some embodiments, the delivery sheath 963 can have a diameter, for example, in the range of 3-5 mm. An inner delivery sheath 964 can be movably disposed within a lumen of the delivery sheath 963 and used to hold the tether 936 while the epicardial pad 939 is being deployed as described in more detail below.

As shown in FIGS. 33 and 34 the epicardial pad 939 includes a frame member 961 and a fabric cover 962. The frame member 961 can be formed with, for example a shape-memory material such as Nitinol® such that the epicardial pad 939 can have a biased expanded configuration as shown in FIGS. 34 and 36, and can be moved to a collapsed configuration as shown in FIG. 33. For example,

15

as shown in FIG. 33 the epicardial pad 939 can be placed within a lumen of the delivery sheath 963 to move the epicardial pad 939 to the collapsed configuration. The fabric cover 962 can be formed with various suitable material(s) such as, for example, polyester, polyethylene or ePTFE.

In use, after a prosthetic mitral valve has been deployed within the heart H (e.g., via a transfemoral delivery approach as described herein or a transatrial delivery approach), the tether 936 attached to the prosthetic valve (not shown) can extend outside the apex of the heart. The epicardial pad 939 can be used to secure the tether 936 and prosthetic valve in a desired position. With the tether 936 extending outside of the heart, the tether 936 can be threaded through a center opening of the epicardial pad 939 and through a lumen of the inner delivery sheath 964, as shown in FIGS. 33 and 34. The outer delivery sheath 963 can be placed over the inner delivery sheath 964 and the epicardial pad 939 to collapse the epicardial pad 939 as shown in FIG. 33. Although not shown, the epicardial pad 936 can be entirely disposed within the lumen of the outer delivery sheath 963 during delivery. As described above, the outer delivery sheath 963 can have a relatively small outer diameter such that it can be inserted through a small incision in the skin of the patient. When the distal end of the delivery sheath 963 is at a desired location near the apex of the heart, the epicardial pad 939 can be moved outside of the delivery sheath 963 such that the epicardial pad 939 can assume its biased expanded configuration as shown in FIGS. 34 and 36. For example, to move the epicardial pad 939 outside of the lumen of the delivery sheath 963, the delivery sheath 963 can be moved proximally, such that the delivery sheath 963 is removed from epicardial pad 939. Alternatively, the epicardial pad 939 can be moved distally outside of the lumen of the delivery sheath 963. For example, a push rod (not shown) can be used, or the inner delivery sheath 964 in which the tether 936 is disposed can be used to move or push the epicardial pad 939 out of the delivery sheath 963.

Prior to moving the expanded epicardial pad 939 into position on the apex of the heart, conventional purse-string sutures 965 at the incision through which the tether 936 extends out of the heart at the apex of the heart can be closed. Although purse-string sutures 965 are illustrated in this embodiment, the epicardial pad 939 can alternatively be implemented without the use of such purse-string sutures 965. The epicardial pad 939, in the expanded configuration, can then be positioned on the apex of the heart. In this embodiment, the epicardial pad 939 includes an integral locking mechanism that includes barbs 967 as shown in FIGS. 37-39. The locking mechanism or barbs 967 can be formed integrally with the frame member 961. As shown in FIGS. 33 and 34, the tether 936 can be inserted through a lumen of the inner delivery sheath 964 such that the delivery sheath 964 can prevent the barbs 967 from contacting the tether 936. For example, the tether 936 can be threaded into the inner delivery sheath 964 prior to the inner delivery sheath 964 and tether 936 being inserted through the center opening of the epicardial pad 939. Thus, the inner delivery sheath 964 can protect the tether 936 from the barbs 967 during deployment of the epicardial pad 939. When the epicardial pad 939 is deployed at the desired position on the apex region of the heart, the inner delivery sheath 964 can be removed uncovering the tether 936 and allowing the barbs 967 to engage or pierce the tether 936 as shown in FIGS. 38 and 39. The barbs 967 can hold or lock the tether 936 and epicardial pad 939 in the desired position. The barbs 967 can be oriented at various different angles relative to a

16

longitudinal axis of the epicardial pad 939, such as, for example, between 45-120 degrees.

In alternative embodiments, other methods of securing the epicardial pad 939 to the heart can be used. For example, in an embodiment in which the epicardial pad 939 does not include an integrated locking mechanism as described above, the distal end portion of the tether 936 can be tied or another securing device such as a clip or locking pin can be used.

FIGS. 40-42 illustrate another embodiment of an expandable epicardial pad device that can be used to secure a tether attached to a prosthetic mitral valve to the heart, for example, at the apex of the heart. An epicardial pad device 1039 (also referred to herein as "epicardial pad" or "pad") can be used, for example, during a procedure to deliver a prosthetic heart valve as described herein. The epicardial pad 1039 can be formed with a small profile such that the epicardial pad 1039 can be delivered to the exterior of the heart via a small incision and a small diameter delivery catheter or sheath (not shown) as described above for epicardial pad 939.

As shown in FIGS. 40-42, the epicardial pad 1039 includes a frame member 1061 and a fabric cover 1062. In this embodiment, the frame member 1061 includes a first frame portion 1068 and a second frame portion 1069. As with the previous embodiment, the frame member 1061 can be formed with, for example a shape-memory material such as Nitinol®, such that the epicardial pad 1039 can have a biased expanded configuration as shown in FIGS. 41 and 42, and can be moved to a collapsed configuration as shown in FIG. 40. For example, although not shown for this embodiment, the epicardial pad 1039 can be placed within a lumen of a delivery sheath to collapse or move the epicardial pad 1039 to the collapsed configuration. In the expanded configuration, the second frame portion 1069 expands within an interior region defined by the first frame portion 1068 as best shown in FIG. 41. In other words, the second frame portion 1069 and the first frame portion 1068 form a double-layer flower-like shape. The fabric cover 1062 can be formed with, for example, various suitable material(s) such as, for example, polyester, polyethylene or ePTFE, as described above for fabric cover 962.

In use, after a prosthetic mitral valve has been deployed within the heart H (FIG. 42), for example, via a transfemoral delivery approach as described herein, the tether 1036 attached to the prosthetic valve (not shown) can extend outside the apex of the heart. The epicardial pad 1039 can be used to secure the tether 1036 and prosthetic valve in a desired position. With the tether 1036 extending outside of the heart, the tether 1036 can be threaded through a lumen of an inner delivery sheath (not shown), such as inner delivery sheath 964 described above, and through a center opening of the epicardial pad 1039. An outer delivery sheath (not shown) can be placed over the inner delivery sheath to collapse the epicardial pad 1039. As described above, the outer delivery sheath can have a relatively small outer diameter such that it can be inserted through a small incision in the skin of the patient. When the distal end of the delivery sheath is at a desired location near the apex of the heart, the epicardial pad 1039 can be moved outside of the outer delivery sheath such that the epicardial pad 1039 can assume its biased expanded configuration as shown in FIGS. 41 and 42 in a similar manner as described above for epicardial pad 939.

Prior to moving the expanded epicardial pad 1039 into position on the apex of the heart, conventional purse-string sutures 1065 at the incision through which the tether 1036

extends out of the heart at the apex of the heart can be closed. As with the previous embodiment, although purse-string sutures **1065** are illustrated in this embodiment, the epicardial pad **1039** can alternatively be implemented without such purse-string sutures **1065**. The epicardial pad **1039**, in the expanded configuration, can then be positioned on the apex of the heart. The epicardial pad **1039** can include an integral locking mechanism, similar to or the same as locking mechanism (e.g., barbs) described above to secure or lock the tether **1036** and epicardial pad **1039** in position on the heart. In alternative embodiments, other methods of securing the epicardial pad **1039** to the heart can be used. For example, as described above, the distal end portion of the tether **1036** can be tied or another securing device such as a clip or locking pin can be used.

FIGS. **43** and **44** illustrate an expandable epicardial pad device **1139** according to another embodiment. The epicardial pad device **1139** can be used in the same or similar manner as described for previous embodiments to secure a tether attached to a prosthetic mitral valve to the heart, for example, at the apex of the heart. The epicardial pad device **1139** (also referred to herein as “epicardial pad” or “pad”) can be used, for example, during a procedure to deliver a prosthetic heart valve as described herein. In this embodiment, the epicardial pad device **1139** includes a balloon member **1155**. The balloon member **1155** can be small in size such that the balloon member **1155** can be delivered to the exterior of the heart via a small incision and a small diameter delivery catheter or sheath (not shown) as described above for previous embodiments.

The balloon member **1155** can define an inner lumen through which the tether **1136** can be inserted. The epicardial pad **1139** can also include an inflation lumen through which an inflation medium can be communicated to and from the balloon member **1155**. For example, the inflation lumen (not shown) can be defined by the balloon member **1155** or by a separate inflation line (not shown) in fluid communication with an interior of the balloon member **1155**.

In use, after a prosthetic mitral valve has been deployed within the heart H (FIG. **43**), as described herein, the tether **1136** attached the prosthetic valve (not shown) can extend outside the apex of the heart. With the tether **1136** extending outside of the heart, the tether **1136** can be threaded or inserted through the lumen of the balloon member **1155** as described above. The balloon member **1155** can be inflated or deflated when the tether **1136** is inserted into the balloon lumen. The balloon member **1155** can be collapsed or deflated (not shown) and then placed within a lumen of a delivery sheath (not shown). The delivery sheath can be inserted through a small incision in the skin of the patient and a distal end of the delivery sheath disposed at a desired location near the apex of the heart. The epicardial pad **1139** (i.e., balloon member **1155**) can be moved outside of the delivery sheath and then can be inflated as shown in FIG. **43**.

Purse-string sutures **1165** at the incision through which the tether **1136** extends out of the heart at the apex of the heart can be closed prior to positioning the epicardial pad **1139** on the apex. As with previous embodiments, although purse-string sutures **1165** are illustrated in this embodiment, the epicardial pad **1139** can alternatively be implemented without such purse-string sutures **1165**. Prior to positioning the balloon member **1155** on the apex of the heart, the balloon member **1155** can be partially deflated or fully deflated. The balloon member **1155** is then moved distally into contact with the heart where it can collapse inwardly upon itself to form a cup shape as the balloon member **1155**

is pushed against the heart, as shown in FIG. **44**. The epicardial pad **1139** and tether **1136** can be secured in the desired position with, for example, clip(s) or a locking pin(s) or by tying the tether **1136**. In some embodiments, the balloon member **1155** is secured by adhesively coupling the balloon member **1155** to the tether **1136** such that the balloon member **1155** is prevented from moving relative to the tether **1136**. In some embodiments, the balloon member **1155** can be adhesively coupled to the tether **1136** and also adhesively coupled to the heart. In some embodiments, the balloon member **1155** is fully deflated and can be filled with an adhesive or a cement material to add strength and rigidity to the balloon member **1155**.

FIGS. **45-47** illustrate yet another embodiment of an epicardial pad device that can be used to secure a tether attached to a prosthetic mitral valve to the heart, for example, at the apex of the heart. The epicardial pad device **1239** (also referred to herein as “epicardial pad” or “pad”) can be used, for example, during a procedure to deliver a prosthetic heart valve as described herein. In this embodiment, the epicardial pad device **1239** includes multiple stackable pad members **1273** that can be sized such that each stackable pad member **1273** can be delivered separately to the exterior of the heart via a small incision and a small diameter delivery catheter or sheath (not shown). When all of the stackable pad members **1273** are implanted and attached to the heart, the stackable pad members **1273** can define a total surface area of, for example, 2 cm. The stackable pad members **1273** can be formed with, for example, suitable polymer or metal materials such as, for example, PEEK plastic, or stainless steel such as, for example, MP35N stainless steel.

In use, after a prosthetic mitral valve has been deployed within the heart H, for example, via a transfemoral delivery approach as described herein, the tether **1236** attached to the prosthetic valve (not shown) can extend outside the apex of the heart. With the tether **1236** extending outside of the heart, a first stackable pad member **1273** can be slid onto the tether **1236**. For example, the stacking members **1273** can define a through-hole in which the tether **1236** can be received. The first stackable pad member **1273** can be slid or moved distally along the tether **1236** until it contacts the surface of the heart H as shown in FIG. **45**. A second stackable pad member **1273** can then be slid distally along the tether **1236** until it contacts the first stackable pad member **1273** and then a third stackable pad member **1273** can be slid distally along the tether **1236** until it contacts the second stackable pad member **1273** as shown in FIG. **46**. Each stackable pad member **1273** can be oriented at a different angle relative to the tether **1236** as shown in FIG. **47**. Using three separate stackable pad members **1273** in this manner can distribute the forces against the surface of the heart more evenly than a single stackable pad member **1273**. After the three stackable pad members **1273** have been positioned against the heart, a locking pin **1274** can be inserted laterally through the tether **1236** to secure the stackable pad members **1273** against the surface of the heart. Although three stackable pad members **1273** are shown with respect to epicardial pad device **1239**, a different number of stackable pads **1273** can alternatively be used, such as, for example, 2, 4, 5, 6, etc. In some embodiments, it may be desirable to insert a locking pin after each stackable pad member **1273** has been positioned.

In some embodiments, prior to deployment of an epicardial pad device to secure a tether and a prosthetic valve in a desired position, as discussed above, for example, with respect to FIGS. **33-37**, an expandable tissue dilator device

can be used to dilate tissue or otherwise create space suitable for delivery and/or deployment of the epicardial pad device. FIGS. 48-50 illustrate an embodiment of an expandable tissue dilator device 1376 (also referred to herein as “tissue dilator”) that can be used to dilate tissue or otherwise create space suitable for delivery and/or deployment of an epicardial pad device 1339 (see FIGS. 51 and 52). The epicardial pad device 1339 can be the same as or similar to any epicardial pad device described herein or in International PCT Application No. PCT/US2014/0049218 (the ‘218 PCT Application), and can be used in the same or similar manner as described for previous embodiments herein or in the ‘218 PCT Application to secure a tether attached to a prosthetic mitral valve to the heart, for example, at the apex of the heart.

The tissue dilator 1376 can be used, for example, during a procedure to deliver a prosthetic heart valve transfemorally as described herein or in any other suitable delivery method (e.g., transapical, transatrial, transjugular). In this embodiment the tissue dilator 1376 can include an expandable member 1377 coupled to a distal end of an elongate member (not shown). The expandable member 1377 can be moved between a collapsed configuration for delivery of the expandable member 1377 and an expanded configuration, in which the size (e.g., diameter) of the expandable member 1377 is greater than when in the collapsed configuration. When in the collapsed configuration, the expandable member 1377 can be introduced through a lumen defined by a small profile delivery sheath 1363 and to a desired location within a patient’s body (e.g., near a patient’s heart H). The expandable member 1377 can be moved to the expanded configuration when at the desired location to dilate surrounding tissue as described in more detail below. In some embodiments, the expandable member 1377 can be a balloon that can be expanded (e.g., inflated) with an inflation medium. For example, the elongate member (not shown) can define a lumen that can communicate an inflation medium to and from the expandable member 1377. The tissue dilator 1376 can be delivered to the exterior of the heart via a small incision I, in which the delivery catheter or sheath 1363 (see FIG. 49) can be inserted. In some embodiments, the delivery sheath 1363 can have a diameter, for example, in the range of 3-5 mm.

In use, after a prosthetic mitral valve has been deployed within the heart H via a transfemoral approach (as described herein), a transapical approach, or other suitable delivery approach, the tether 1336 attached to the prosthetic valve (not shown) can extend outside the apex of the heart H and outside the patient’s body via a small incision I (see, e.g., FIG. 48). A proximal end of the tether 1336 can be threaded into and through a distal end of a lumen of the delivery sheath 1363. In this manner, the tether 1336 can provide a guide or otherwise assist in the insertion and movement of the delivery sheath 1363 through the incision I in the skin of the patient. A distal end 1378 of the delivery sheath 1363 can be moved along the tether 1336 and disposed at a desired location near the apex of the heart H (see FIG. 49). The expandable member 1377 of the tissue dilator 1376, when in its collapsed or deflated configuration, can be delivered to the apex region of the heart via the delivery sheath 1363. More specifically, the tissue dilator 1376, with the expandable member 1377 in its collapsed or deflated configuration, can be inserted through the proximal end of the lumen of the delivery sheath 1363, and moved distally towards the distal end of the delivery sheath 1363. In some embodiments, the tissue dilator 1376 can be inserted into the delivery sheath 1363 prior to the delivery sheath 1363 being inserted into the

body of the patient. The expandable member 1377 of the tissue dilator 1376 can then be extended outside the distal end of the lumen of the delivery sheath 1363 (see FIG. 49), and moved to its expanded configuration (e.g., inflated), as shown in FIG. 50. For example, to move the expandable member 1377 of the tissue dilator 1376 outside of the lumen of the delivery sheath 1363, the delivery sheath 1363 can be moved proximally, such that the delivery sheath 1363 is removed from the expandable member 1377 of the tissue dilator 1376. Alternatively or additionally, the tissue dilator 1376 can be moved distally such that the expandable member 1377 is moved outside of the lumen of the delivery sheath 1363.

With the expandable member 1377 disposed outside the heart of the patient (e.g., between the patient’s ribs and the heart) the expandable member 1377 can be moved to its expanded configuration such that tissue near the expandable member 1377 is dilated by the pressure exerted by the expandable member 1377 on the surrounding tissue. For example, the elongate member of the tissue dilator 1376 can be fluidically coupled directly, or via a fluid line (not shown), to a source of an inflation medium suitable to expand (e.g., inflate) the expandable member 1377. When the expandable member 1377 is disposed at the desired location in the patient near the apex of the heart, the expandable member 1377 can be expanded. In this manner, the tissue dilator 1376 can be used to dilate tissue or otherwise create space suitable for delivery and/or deployment (e.g., expansion and securement to the heart H) of the epicardial pad device 1339, as described in more detail below.

After inflation of the expandable member 1377 of the tissue dilator 1376, and the dilation of the surrounding tissue, the expandable member 1377 of the tissue dilator 1376 can be deflated or collapsed and withdrawn proximally (not shown) through the lumen of the delivery sheath 1363 and outside of the patient. In some embodiments, the delivery sheath 1363 can be removed from the patient’s body at the same time or after the tissue dilator 1376 is removed. The tether 1336 extending outside of the patient can be threaded through a center opening of the epicardial pad 1339 and through a lumen of an inner delivery sheath (not shown). The epicardial pad 1339 can be used to secure the tether 1336 and the prosthetic valve (not shown) in a desired position. The delivery sheath 1363 can be placed over the inner delivery sheath and the epicardial pad 1339 to collapse the epicardial pad 1339 in a similar manner as described above for previous embodiments.

The delivery sheath 1363 can then be re-inserted through the small incision I in the skin of the patient and a distal end of the delivery sheath 1363 disposed near the apex of the heart. When the distal end of the delivery sheath 1363 is at the desired location near the apex of the heart, the epicardial pad 1339 can be moved outside the distal end of the delivery sheath 1363 such that the epicardial pad 1339 can assume a biased expanded configuration (see FIG. 51), similar to, for example, the epicardial pad 936 described above, or can be moved to an expanded configuration as described above for epicardial pad 1139. For example, to move the epicardial pad 1339 outside of the lumen of the delivery sheath 1363, the delivery sheath 1363 can be moved proximally, such that the delivery sheath 1363 is removed from epicardial pad 1339. Alternatively, the epicardial pad 1339 can be moved distally outside of the lumen of the delivery sheath 1363. For example, a push rod (not shown) can be used, or the inner delivery sheath (not shown) in which the tether 1336 is disposed can be used to move or push the epicardial pad

1339 out of the delivery sheath 1363. Upon delivery and deployment of the epicardial pad 1339 about the heart H, the delivery sheath 1363 can be removed from the patient and the incision I can be closed with sutures S (see FIG. 52).

In other alternative embodiments, an expandable tissue dilator device can define an inner lumen through which the tether can be inserted. The tissue dilator can also include an inflation lumen through which an inflation medium can be communicated to and from the expandable member of the tissue dilator, as previously described. For example, the inflation lumen can be defined by the tissue dilator or by a separate inflation line that can be disposed within a lumen of the tissue dilator (e.g., a lumen defined by the elongate member of the tissue dilator). In such embodiments, in use, after a prosthetic mitral valve has been deployed within the heart, the tether attached to the prosthetic valve can extend outside the apex of the heart, as described with respect to previous embodiments. With the tether extending outside of the heart, the tether can be threaded or inserted through the lumen of the tissue dilator. As described with respect to previous embodiments, the expandable member of the tissue dilator can be collapsed or deflated and placed within the lumen of the delivery sheath. The delivery sheath can be inserted through a small incision in the skin of the patient and a distal end of the delivery sheath disposed at a desired location near the apex of the heart. The expandable member of the tissue dilator can be moved outside a distal end of the delivery sheath and expanded at or near the heart (e.g., the apex region) as shown and described with respect to the tissue dilator 1376.

After expanding the expandable member of the tissue dilator, and in turn creating space suitable for delivery and/or deployment of an epicardial pad device, the tissue dilator can be collapsed or deflated and withdrawn proximally about the tether and through the lumen of the delivery sheath and outside of the patient. The delivery sheath can be withdrawn from the patient's body through the small incision I. Upon removal of the tissue dilator and the delivery sheath from the tether, the proximal end of the tether can be threaded through a center opening of the epicardial pad and an inner sheath, and the epicardial pad can be delivered to and deployed at the heart using the delivery sheath, as described in previous embodiments.

In alternative embodiments, the tissue dilator can be delivered through a lumen of a delivery sheath separate from the delivery sheath through which the epicardial pad is delivered. Said another way, the tissue dilator can be delivered through a first delivery sheath and the epicardial pad can be delivered through a second delivery sheath.

In yet other alternative embodiments, a delivery sheath can include multiple lumens (e.g., two lumens). In such embodiments, the tether can be routed or threaded through a first lumen of the delivery sheath, and the tissue dilator can be routed and delivered through the second lumen of the delivery sheath. In such an embodiment, after the tissue dilator has been used to dilate the surrounding tissue near the apex of the heart, the tissue dilator can be removed leaving the delivery sheath within the body of the patient. The proximal end of the tether (extending through the first lumen of the delivery sheath) can then be threaded through an epicardial pad and an inner sheath as described above. The epicardial pad and inner sheath can then be inserted into the proximal end of the delivery sheath (e.g., delivery sheath 1363) and moved distally to the distal end of the delivery sheath. For example, the inner sheath can push the epicardial pad distally along the tether. The epicardial pad can then be

deployed out the distal end of the delivery sheath and secured to the apex of the heart, as described above for previous embodiments.

In another embodiment, a delivery device can define a lumen that can receive both a dilator device and an expandable epicardial pad. For example, FIGS. 53-57 illustrate an embodiment of an epicardial pad delivery device that can be used to deliver an expandable epicardial pad that can be used to secure a tether attached to a prosthetic mitral valve to the heart, for example, at the apex of the heart. An expandable epicardial pad delivery device 1401 (also referred to herein as "pad delivery device" or "delivery device") can be used, for example, during a procedure to deliver a prosthetic heart valve (e.g., a prosthetic mitral valve) as described herein. The delivery device 1401 can be used to deliver an expandable epicardial pad 1439. The delivery device 1401 can have a small outer diameter such that the delivery device 1401 can be inserted through a small incision in a patient to deliver the epicardial pad 1439 to the exterior of the heart of the patient. The delivery device 1401 includes an outer delivery sheath 1463, an expandable tissue dilator device 1476, and a stopper tube 1489.

The expandable epicardial pad 1439 (also referred to as "epicardial pad" or "pad") can have a collapsed configuration for delivery of the pad 1439 within a body of a patient, and an expanded configuration. When in the collapsed configuration, the pad 1439 can have a small profile such that the pad 1439 can be disposed within a lumen of the delivery device 1401. A tether 1436 attached to a prosthetic mitral valve (not shown) deployed within the heart H can extend through the delivery device 1401 as described in more detail below.

The delivery sheath 1463 includes an elongate member 1411 and at least one retracting element 1479. The delivery sheath 1463 also defines a lumen 1413 that can receive therethrough the dilator device 1476. The elongate member 1411 can have an outer diameter, for example, in the range of 3-5 mm. The retracting element 1479 can be located at or near a distal end of the delivery sheath 1463. The at least one retracting element 1479 can include a lip that extends partially or fully around the circumference of the delivery sheath 1463. The lip can be shaped such that the retracting element 1479 can pull tissue proximally when the delivery sheath 1463 is moved in a proximal direction. For example, in this embodiment, at least a portion of the lip can form an angle relative to the elongate member 1411 such that the lip is capable of catching and pulling tissue. For example, the retracting element 1479 can be used to retract or separate pericardium tissue from epicardial tissue at the surface of the heart as described in more detail below. The angle can be, for example, about 90°. In other configurations, the angle can be greater than or less than 90°.

In some embodiments, the retracting element 1479 can include a threaded feature (not shown). Rotation of the delivery sheath 1463 in a first direction can cause the threaded feature to engage with and/or capture tissue. Rotation of the delivery sheath 1463 in a second direction opposite the first direction can cause the thread feature to release the tissue. For example, depending on the direction of thread or threads in the threaded feature, the threaded feature could be rotated clockwise to capture the tissue (e.g., pericardium) such that the retracting element 1479 can be used to pull the tissue proximally. To release the tissue from the retracting element 1479, the threaded feature can be rotated counter-clockwise. In other embodiments, the retracting element 1479 can be configured to release captured tissue when the retracting element 1479 reaches a

predetermined tension. In some embodiments, the retracting element **1479** can be collapsible from an expanded configuration in which the retracting element **1479** engages with and captures tissue to a collapsed configuration in which the retracting element **1479** disengages with the captured tissue.

The expandable tissue dilator device **1476** (also referred to herein as “tissue dilator” or “dilator device”) can be movably disposed within the lumen **1413** of the delivery sheath **1463**. The tissue dilator **1476** can be used to dilate tissue or otherwise create space suitable for delivery and/or deployment of the epicardial pad device **1439**. The tissue dilator **1476** can include an expandable member **1477** coupled to a distal end of an elongate member **1491** and can define a lumen **1415**. The expandable member **1477** can be moved between a collapsed configuration for delivery of the expandable member **1477** and an expanded configuration, in which the size (e.g., diameter) of the expandable member **1477** is greater than when in the collapsed configuration. When in the collapsed configuration, the expandable member **1477** can be introduced through the lumen **1413** of the delivery sheath **1463** to a desired location within a patient’s body (e.g., near a patient’s heart H). The expandable member **1477** can be moved to the expanded configuration when at the desired location to dilate surrounding tissue as described in more detail below. In some embodiments, the expandable member **1477** can be a balloon that can be expanded (e.g., inflated) with an inflation medium. For example, the elongate member **1491** can define an inflation lumen (not shown) that can communicate an inflation medium to and from the expandable member **1477**.

As described above, the expandable epicardial pad **1439** can have a collapsed configuration for delivery of the epicardial pad **1439** to the exterior of the heart. As shown in FIGS. **53** and **54**, in this embodiment, the epicardial pad **1439** is disposed within a lumen **1415** of the tissue dilator **1476** to deliver the epicardial pad **1439** to the heart. The epicardial pad **1439** can also define an inner lumen (not shown) through which the tether **1436** can be inserted. The epicardial pad **1439** can be the same as or similar to any epicardial pad devices described herein or in International PCT Application No. PCT/US2014/0049218 (the ‘218 PCT Application), and can be used in the same or similar manner as described for other embodiments herein or in the ‘218 PCT Application to secure a tether attached to a prosthetic mitral valve to the heart, for example, at the apex of the heart. For example, the epicardial pad **1439** can include an expandable balloon that is the same as or similar to the balloon member **1155** described above with reference to FIG. **43**. Alternatively, although not shown, the epicardial pad **1439** can be biased toward an expanded configuration and be movable between a collapsed configuration in which the epicardial pad **1439** is compressed within the tissue dilator **1476** and the expanded configuration when moved out of the tissue dilator **1476**.

The stopper tube **1489** can define an inner lumen through which the tether **1436** can be inserted. The tether **1436** can be movably disposed within the stopper tube **1489** such that the stopper tube **1489** can control the movement of the expandable epicardial pad **1439**. Said another way, the stopper tube **1489** can be used to prevent proximal movement of the expandable epicardial pad **1439** and to push the expandable epicardial pad **1439** distally relative to the tissue dilator **1476** and/or the outer delivery sheath **1463**. The stopper tube **1489** can be releasably attachable to the epicardial pad **1439** such that the stopper tube **1489** is secured to the epicardial pad **1439** during insertion and/or delivery of the epicardial pad **1439**. In other embodiments, the stopper

tube **1489** is configured to abut a portion of the epicardial pad **1439** such that it can limit proximal movement of the epicardial pad **1439** and push the epicardial pad **1439** distally. The stopper tube **1489** can also include an inflation lumen (not shown) through which an inflation medium can be communicated to and from the epicardial pad **1439**. Alternatively, the inflation lumen can be defined by a separate inflation line (not shown) in fluid communication with an interior of the epicardial pad **1439**.

In use, after a prosthetic mitral valve (not shown) has been deployed within the heart H via a transfemoral approach (as described herein), a transapical approach, a transjugular approach, or another suitable delivery approach, the tether **1436** attached to the prosthetic valve can extend outside the apex of the heart H and outside the patient’s body via a small incision (similar to incision I as shown above in FIG. **48**). A proximal end of the tether **1436** can be threaded into and through the delivery device **1401**. Specifically, when the delivery device **1401** is in the configuration of FIG. **53** in which the epicardial pad **1439** and stopper tube **1489** are disposed within the lumen **1415** of the tissue dilator **1476** and the tissue dilator **1476** is disposed within the lumen **1413** of the delivery sheath **1463**, the proximal end of the tether **1436** can be threaded through the lumen of the epicardial pad **1439** and the lumen of the stopper tube **1489**. In this manner, the tether **1436** can provide a guide or otherwise assist in the insertion and movement of the delivery device **1401** through the incision in the skin of the patient. A distal end of the delivery device **1401** can be moved along the tether **1436** and disposed at a desired location near the apex of the heart H. A distal end **1478** of the delivery sheath **1463** can then be inserted through the pericardium P of the heart H such that the retracting element **1479** is between the pericardium P and the epicardium E.

FIG. **54** is a cross-sectional illustration of the delivery device **1401** after insertion of the distal end **1478** of the delivery device **1401** between the pericardium P and the epicardium E. As shown in FIG. **54**, the delivery sheath **1463** can be pulled proximally such that the pericardium P is pulled proximally by the retracting element **1479** relative to the epicardium E, creating a space between the pericardium P and the epicardium E. The proximal movement of the delivery sheath **1463** relative to the tissue dilator **1476** results in the expandable member **1477** being disposed distally of the distal end **1478** of the delivery sheath **1463**. Alternatively or additionally, the tissue dilator **1476** can be moved distally such that the expandable member **1477** is moved outside of the lumen of the delivery sheath **1463**.

Alternatively, rather than arranging the tissue dilator **1476**, the epicardial pad **1439**, and the stopper tube **1489** within the delivery sheath **1463** prior to insertion of the delivery device **1401**, in some embodiments, the components of the delivery device **1401** can be inserted in stages. The tether **1436** can be threaded into and through the lumen **1413** of the delivery sheath **1463** and the delivery sheath **1463** can then be moved along the tether **1436** and inserted through the pericardium P of the heart H such that the retracting element **1479** is disposed between the pericardium P and the epicardium E. The tissue dilator **1476** can then be delivered to the apex region of the heart H via the delivery sheath **1463**. More specifically, the tissue dilator **1476**, with the expandable member **1477** in its collapsed or deflated configuration, can be inserted through the proximal end of the lumen **1413** of the delivery sheath **1463**, and moved distally towards the distal end **1478** of the delivery sheath **1463**. The tether **1436** extending outside of the patient can then be threaded through a center opening of the epicardial

pad 1439. Before insertion, the delivery sheath 1463 and the tissue dilator 1476 can be placed over the epicardial pad 1439 to collapse the epicardial pad 1439 in a similar manner as described above for previous embodiments. Alternatively, the epicardial pad 1439 can be threaded over the tether 1436 and into the lumen 1413 of the tissue dilator 1476.

FIG. 55 is a side view illustration of the delivery device 1401 after the expandable member 1477 has been expanded. As shown in FIG. 55, after the delivery sheath 1463 has been retracted and the expandable member 1477 is positioned distally of the distal end of the delivery sheath 1463 between the pericardium P and the epicardium E, the expandable member 1477 can be moved to its expanded configuration such that tissue near the expandable member 1477 is dilated by the pressure exerted by the expandable member 1477 on the surrounding tissue. For example, the elongate member 1491 of the tissue dilator 1476 can be fluidically coupled directly or via a fluid line (not shown) to a source of an inflation medium suitable to expand (e.g., inflate) the expandable member 1477. When the expandable member 1477 is disposed at the desired location in the patient, the expandable member 1477 can be expanded. In this manner, the tissue dilator 1476 can be used to dilate tissue or otherwise create space suitable for delivery and/or deployment (e.g., expansion and securement to the heart H) of the epicardial pad device 1439, as described in more detail below.

After inflation of the expandable member 1477 of the tissue dilator 1476, and the dilation of the surrounding tissue, the expandable member 1477 of the tissue dilator 1476 can be deflated or collapsed and withdrawn proximally into the lumen 1413 of the delivery sheath 1463 or through the lumen 1413 of the delivery sheath 1463 and outside of the patient. The proximal movement of the tissue dilator 1476 relative to the epicardial pad 1439 causes the epicardial pad 1439 to be disposed distally of the distal end of both the delivery sheath 1463 and the tissue dilator 1476. The stopper tube 1489 can prevent undesired proximal movement of the epicardial pad 1439. Alternatively or additionally, the epicardial pad 1439 can be moved distally outside of the lumen of the delivery sheath 1463 and the lumen of the tissue dilator 1476. For example, the stopper tube 1489 can be used to move or push the epicardial pad 1439 out of the delivery sheath 1463. When the epicardial pad 1439 has been moved distally relative to the delivery sheath 1463 and the tissue dilator 1476, the epicardial pad 1439 can assume a biased expanded configuration, similar to, for example, the epicardial pad 936 described above, or can be moved to an expanded configuration as described above for epicardial pad 1139. The stopper tube 1489 can then be moved distally to position the epicardial pad 1439 against the apex of the heart H as shown in FIG. 56. When the epicardial pad 1439 is in the desired position, the stopper tube 1489 can release or be detached from the epicardial pad 1439.

Upon delivery and deployment of the epicardial pad 1439 at the apex of the heart H, the delivery sheath 1463, tissue dilator 1476, and stopper tube 1489 can be removed from the patient and the incision can be closed with sutures (similar to above with reference to FIG. 52). The retracting element 1479 can be disengaged from the tissue of the pericardium P. The delivery sheath 1463, the tissue dilator 1476, and the stopper tube 1489 can be removed from the patient's body at the same time or in stages. The epicardial pad 1439 and tether 1436 can be secured in the desired position with, for example, one or more clips or one or more locking pins or by tying the tether 1436.

In some embodiments, the delivery device 1401 can include an anchoring member in the form of an internal balloon that can be disposed inside the heart during the delivery of the epicardial pad 1439. For example, FIG. 57 is an illustration of the embodiment of FIGS. 53-56 including an optional expandable anchoring member 1492. The expandable anchoring member 1492 includes an elongate member and a locating balloon on the distal end of the elongate member. The elongate member can define an inflation lumen through which the locating balloon can be expanded (e.g., inflated) with an inflation medium. Said another way, the elongate member can define an inflation lumen that can communicate an inflation medium to and from the locating balloon. Additionally, the elongate member and the locating balloon can define a tether lumen (not shown).

In use, the tether 1436 can be threaded through the tether lumen of the expandable anchoring member 1492. With the locating balloon in an unexpanded configuration, the expandable anchoring member 1492 can be pushed or moved distally through the lumen of the stopper tube 1489 and the epicardial pad 1439. When the delivery device 1401 is positioned in the desired location near the apex of the heart H, the elongate member of the expandable anchoring member 1492 can be pushed distally, pushing the locating balloon through the puncture site in the apex of the heart H through which the tether 1436 extends.

With the locating balloon disposed within the left ventricle LV, the locating balloon can be transitioned from an unexpanded configuration (not shown) to an expanded configuration, as shown in FIG. 57. With the locating balloon in its expanded configuration, the elongate member of the expandable anchoring member 1492 can be pulled proximally. The proximal movement of the elongate member of the expandable anchoring member 1492 pulls the locating balloon toward the apex of the heart H, helping to stabilize the location of the tissue surrounding the puncture site for placement of the epicardial pad 1439. After the epicardial pad 1439 is positioned against the outside of the heart H, the locating balloon can be deflated and withdrawn through the apex of the heart H and the epicardial pad 1439 by pulling proximally on the elongate member of the expandable anchoring member 1492.

FIGS. 58-61 illustrate an embodiment of an expandable epicardial pad assembly. The expandable epicardial pad assembly can be used to secure a tether attached to a prosthetic mitral valve to the heart, for example, at the apex of the heart. An expandable epicardial pad assembly 1502 (also referred to herein as "pad assembly") can be used, for example, during a procedure to deliver a prosthetic heart valve as described herein. The epicardial pad assembly 1502 can be formed with a small profile, or can be moved between a collapsed configuration for delivery in which the pad assembly 1502 has a small profile, and an expanded configuration for deployment/implantation within a patient's body. For example, as described above for previous embodiments, the epicardial pad assembly 1502 can be delivered to the heart H via a delivery device 1501 including a small diameter delivery catheter or sheath 1563 that can be inserted through a small incision in the patient. In some embodiments, the delivery sheath 1563 can have a diameter, for example, in the range of 3-5 mm.

In this embodiment, the pad assembly 1502 can include an inner anchor 1592 and an expandable epicardial pad 1539 (shown in FIGS. 59-61). The inner anchor 1592 includes a protrusion 1593. The protrusion 1593 can be shaped and sized to fill the puncture site in the apex of the heart H

through which a tether **1536** coupled to a prosthetic heart valve (not shown) extends. The expandable epicardial pad **1539** can be the same as or similar to any epicardial pad device described herein or in International PCT Application No. PCT/US2014/0049218 (the '218 PCT Application), and can be used in the same or similar manner as described for previous embodiments herein or in the '218 PCT Application to secure a tether attached to a prosthetic mitral valve to the heart, for example, at the apex of the heart. The epicardial pad **1539** can be used to secure the tether **1536** and the prosthetic valve (not shown) in a desired position.

The expandable epicardial pad **1539** and the inner anchor **1592** are attached via a first suture **1594** and a second suture **1595**. The first suture **1594** is attached to the inner anchor **1592** via a first suture knot **1596** and the second suture **1595** is attached to the inner anchor **1592** via a second suture knot **1596**. The first suture **1594** also includes a third knot **1598** and a fourth knot **1599**. The third knot **1598** and the fourth knot **1599** are sliding knots configured to be tightened to secure the expandable epicardial pad **1539** against the heart H as described in more detail below.

In addition to the delivery sheath **1563**, the delivery device **1501** includes an inner stopper tube **1589A** and an outer stopper tube **1589B**. The outer stopper tube **1589B** is movably disposed within a lumen of the delivery sheath **1563**, and the inner stopper tube **1589A** is movably disposed within a lumen of the outer stopper tube **1589A**. The inner stopper tube **1589A** can define an inner lumen through which the tether **1536** can be inserted. The inner stopper tube **1589A** can be coupled to the inner anchor **1592** and control the movement of the inner anchor **1592**. For example, the inner stopper tube **1589A** can be used to prevent proximal movement of the inner anchor **1592** and to push the inner anchor **1592** distally relative to the delivery sheath **1563** and/or the outer stopper tube **1589B**. The inner stopper tube **1589A** can be releasably coupled to the inner anchor **1592** such that the inner stopper tube **1589A** is secured to the inner anchor **1592** during insertion and/or delivery of the epicardial pad assembly **1501**. In other embodiments, the inner stopper tube **1589A** is configured to abut a portion of the inner anchor **1592** such that it can limit proximal movement of the inner anchor **1592** and push the inner anchor **1592** distally.

Similarly, the outer stopper tube **1589B** can define an inner lumen through which the inner stopper tube **1589A** can be inserted. The outer stopper tube **1589B** can be coupled to and can control movement of the epicardial pad **1539**. For example, the outer stopper tube **1589B** can be used to prevent proximal movement of the epicardial pad **1539** and to push the epicardial pad **1539** distally relative to the delivery sheath **1563** and/or the inner stopper tube **1589A**. The outer stopper tube **1589B** can be releasably coupled to the epicardial pad **1539** such that the outer stopper tube **1589B** is secured to the epicardial pad **1539** during insertion and/or delivery of the epicardial pad assembly **1501**. In other embodiments, the outer stopper tube **1589B** is configured to abut a portion of the epicardial pad **1539** such that it can limit proximal movement of the epicardial pad **1539** and push the epicardial pad **1539** distally.

The inner anchor **1592** can be formed with, for example, suitable medical-grade polymer or metal materials such as, for example, PEEK plastic, or stainless steel such as, for example, MP35N stainless steel. The inner anchor **1592** can also be formed with, for example, purified terephthalic acid (PTA), polylactic acid (PLA), or Nitinol®. In some embodiments, the inner anchor **1592** can be configured to remain in the heart. In other embodiments, the inner anchor **1592** can

be formed of a bioabsorbable material or a bioresorbable material such that initially, the inner anchor **1592** can contribute to the stability of the epicardial pad **1539**, and after a period of time, the inner anchor **1592** can be absorbed into the body. For example, in some cases, the inner anchor **1592** can be absorbed or at least partially absorbed when ingrowth of the epicardial pad **1539** to the heart has at least partially begun.

In use, after a prosthetic mitral valve has been deployed within the heart H via a transfemoral approach (as described herein), a transapical approach, or another suitable delivery approach, the tether **1536** attached to the prosthetic valve (not shown) can extend outside the apex of the heart H and outside the patient's body via a small incision (similar to incision I as shown above in FIG. 48). The delivery sheath **1563** can be placed over the inner anchor **1592** and the epicardial pad **1539** to collapse the inner anchor **1592** and the epicardial pad **1539** in a similar manner as described above for previous embodiments. A proximal end of the tether **1536** can be threaded into and through a distal end of a lumen of the outer delivery sheath **1563** and through a center opening of the inner anchor **1592** and a center opening of the epicardial pad **1539**. In this manner, the tether **1536** can provide a guide or otherwise assist in the insertion and movement of the delivery sheath **1563** through the incision in the skin of the patient. A distal end **1578** of the delivery sheath **1563** can be moved along the tether **1536** and disposed at a desired location near the apex of the heart H. The distal end **1578** of the delivery sheath **1563** can then be inserted through the apex of the heart H such that the distal end **1578** is positioned in the left ventricle LV. Alternatively, the tether **1536** can be threaded into the delivery sheath **1563** and the delivery sheath **1563** can be positioned in the left ventricle LV prior to the pad assembly **1502** being inserted into the lumen of the delivery sheath **1563**. In such a case, the inner anchor **1592** and epicardial pad **1539** can be moved at least partially through the distal end **1578** of the delivery sheath **1563** via the inner stopper tube **1589A** and the outer stopper tube **1589B**, respectively.

With the distal end **1578** of the delivery sheath **1563** positioned in the left ventricle LV, the inner anchor **1592** can be extended outside the distal end of the lumen of the delivery sheath **1563** and moved to its expanded configuration in the left ventricle LV, as shown in FIG. 59. For example, to move the inner anchor **1592** outside of the lumen of the delivery sheath **1563**, the delivery sheath **1563** can be moved proximally relative to the inner stopper tube **1589A**, such that the delivery sheath **1563** is removed from the inner anchor **1592**. Alternatively or additionally, the inner anchor **1592** can be pushed distally via a distal movement of the inner stopper tube **1589A** such that the inner anchor **1592** is moved outside of the lumen of the delivery sheath **1563**.

When the inner anchor **1592** is positioned in the left ventricle LV, the delivery sheath **1563** can be moved proximally such that the delivery sheath **1563** is withdrawn from the left ventricle LV through the apex of the heart H. As shown in FIG. 60, when the distal end **1578** of the delivery sheath **1563** is at the desired location near the apex of the heart H outside of the left ventricle LV, the epicardial pad **1539** can be moved outside the distal end **1578** of the delivery sheath **1563** such that the epicardial pad **1539** can assume a biased expanded configuration, similar to, for example, the epicardial pad **936** described above, or can be moved to an expanded configuration as described above for epicardial pad **1139**. For example, to move the epicardial pad **1539** outside of the lumen of the delivery sheath **1563**,

the delivery sheath **1563** can be moved proximally relative to the outer stopper tube **1589B**, such that the delivery sheath **1563** is removed from the epicardial pad **1539**. Alternatively, the epicardial pad **1539** can be pushed distally via a distal movement of the outer stopper tube **1589B** such that the epicardial pad **1539** is moved outside of the lumen of the delivery sheath **1563**.

As shown in FIG. **60**, after the epicardial pad **1539** has moved to its expanded configuration, the third knot **1598** and the fourth knot **1599** can be slid distally along the first suture **1594** and the second suture **1595**, respectively, to secure the epicardial pad **1539** and the inner anchor **1592** in position. In some embodiments, the third knot **1598** and the fourth knot **1599** can be tightened against the epicardial pad **1539** by pulling on the first suture **1594** and the second suture **1595**. In other embodiments, the delivery assembly **1501** can include a first suture tube (not shown) and a second suture tube (not shown). The first suture **1594** can be threaded through the first suture tube and the second suture **1595** can be threaded through the second suture tube. The first suture tube and the second suture tube can be slid along the first suture **1594** and the second suture **1595**, respectively, to push the third knot **1598** and the fourth knot **1599** against the epicardial pad **1539** to secure the epicardial pad **1539** and the inner anchor **1592** against the apex of the heart H.

Upon delivery and deployment of the epicardial pad **1539** at the apex of the heart H, the delivery sheath **1563**, the inner stopper tube **1589A** and the outer stopper tube **1589B** can be removed from the patient. The epicardial pad **1539** and tether **1536** can be secured in the desired position with, for example, clip(s) or a locking pin(s) or by tying the tether **1536**.

FIG. **61** is an illustration of a cutting assembly **1503** that can optionally be used to cut or sever the tether **1536**, the first suture **1594**, and/or the second suture **1595**. The cutting assembly **1503** includes an outer tube **1505**, an inner tube **1506**, and a rotational knob **1504**. The outer tube **1505** and the inner tube **1506** each define a distal end opening and a side opening. A first sharp edge **1507** surrounds the side opening of the outer tube **1505** and a second sharp edge **1508** surrounds the side opening of the inner tube **1506**. The outer tube **1505** and the inner tube **1506** are arranged such that the inner tube **1506** is movably disposed within the outer tube **1505**. For example, the inner tube **1506** can be rotationally movable relative to the outer tube **1505** and vice versa. Additionally, the distal end opening of the inner tube **1506** and the distal end opening of the outer tube **1505** can be coaxial.

In use, the side openings of the outer tube **1505** and the inner tube **1506** can be aligned such that the side openings at least partially overlap to collectively define an opening between the first sharp edge **1507** and the second sharp edge **1508**. The tether **1536**, the first suture **1594**, and the second suture **1595** can be inserted through the distal end opening in the inner tube **1506** and threaded through the combined opening defined between the first sharp edge **1507** and the second sharp edge **1508**. The rotational knob **1504** can rotate the inner tube **1506** relative to the outer tube **1507** (or vice versa) such that the second sharp edge **1508** rotates toward the first sharp edge **1507** and pinches the tether **1536**, the first suture **1594**, and/or the second suture **1595** between the first sharp edge **1507** and the second sharp edge **1508**. The inner tube **1506** and the outer tube **1507** can be further rotated relative to each other such that the first sharp edge **1507** and the second sharp edge **1508** cut the tether **1536**, the first suture **1594**, and/or the second suture **1595**.

In some embodiments, the cutting assembly **1503** can be used to cut the tether **1536** at a first time and be used to cut the first suture **1594** and/or the second suture **1595** at a second time before or after the first time. In other embodiments, the cutting assembly **1503** can be used to cut the tether **1536**, the first suture **1594**, and the second suture **1595** in one motion. In some embodiments, a first cutting assembly can be used to cut the tether **1536** and a second cutting assembly can be used to cut the first suture **1594** and/or the second suture **1595**. The first cutting assembly can be a different size than the second cutting assembly depending on the size of the tether **1536**, the first suture **1594** and/or the second suture **1595**. In still other embodiments, the tether **1536**, the first suture **1594** and/or the second suture **1595** can be trimmed using scissors, cauterization, or any other suitable cutting methods. Additionally, in some embodiments, the cutting assembly **1503** can be used to slide the third knot **1598** and the fourth knot **1599** distally along the first suture **1594** and the second suture **1595**, respectively, to secure the epicardial pad **1539** and the inner anchor **1592** against the apex of the heart H.

FIGS. **62-64** illustrate another embodiment of an expandable epicardial pad delivery device that can be used to deliver an expandable epicardial pad. The expandable epicardial pad can be used to secure a tether attached to a prosthetic mitral valve to the heart, for example, at the apex of the heart. An expandable epicardial pad delivery device **1601** (also referred to herein as “pad delivery device” or “delivery device”) can be used, for example, during a procedure to deliver a prosthetic heart valve as described herein. The delivery device **1601** can be used to deliver an expandable epicardial pad **1639**. The expandable epicardial pad **1639** includes a spiral member **1609** and a locking member **1616** at a proximal end portion of the spiral member **1609**. The spiral member **1609** can be formed such that the spiral member **1609** can have a small profile for delivery of the spiral member **1609** within a delivery sheath of the delivery device **1601**. The delivery device **1601** can include an outer delivery sheath **1663** that has a small outer diameter such that the epicardial pad **1639** can be delivered within the delivery device **1601** to the exterior of the heart via a small incision. The delivery device **1601** also includes an inner tube **1619**, and a handle assembly **1617**. The delivery device **1601** can also include a push rod **1618** to control the location of the locking member **1616** relative to the inner tube **1619** and outer delivery sheath **1663**.

The outer delivery sheath **1663** extends from the handle **1617** and defines a lumen **1613**. The outer delivery sheath **1663** can have an outer diameter, for example, in the range of 3-5 mm. The inner tube **1619** can be moveably disposed within the lumen **1613** of the outer delivery sheath **1663**. The inner tube **1619** defines a lumen (not shown) configured to receive a portion of the tether **1636**. The push rod **1618** can be movably disposed within the lumen **1613** such that the push rod **1618** can control the movement of the locking member **1616** and the spiral member **1609**. For example, the push rod **1618** can be used to push the locking member **1616** until most or all of the spiral member **1609** and/or the locking member **1616** has been pushed out of the distal end of the outer delivery sheath **1663**.

The spiral member **1609** is configured to be manipulated and/or deformed (e.g., compressed and/or expanded) and, when released, return to its original (undeformed) shape. To achieve this, the spiral member **1609** can be formed of various materials, such as biocompatible metals or plastics, that have shape memory properties. For example, the spiral member **1609** can be formed with, for example, a suitable

polymer, such as, for example, PEEK plastic. With regards to metals, Nitinol® has been found to be especially useful since it can be processed to be austenitic, martensitic or super elastic. Other shape memory alloys, such as Cu—Zn—Al—Ni alloys, and Cu—Al—Ni alloys, may also be used. The spiral member 1609 can also optionally be covered at least in part with a polyester material to promote ingrowth.

The spiral member 1609 can be moved from a first configuration when the spiral member 1609 is disposed within the outer delivery sheath 1663 to a second, expanded configuration when the spiral member 1609 is unconstrained (e.g., outside the lumen of the delivery sheath 1663). In the first configuration, the spiral member 1609 is radially compressed and placed into an elongated, stretched shape within the lumen 1613 of the outer delivery sheath 1663 as partially shown in FIG. 62. For example, the spiral member 1609 may be shaped as an elongated spiral or coil. In the second, expanded configuration, as shown in FIG. 63, the coils of the spiral member 1609 are unconstrained by the delivery sheath 1663 and collectively have a larger diameter than when in the first configuration. The spiral member 1609 can then be moved to a third configuration in which the spiral member 1609 is compressed axially such that the coils of the spiral member 1609 are collapsed upon each other and form a collapsed, flattened spiral shape (as shown in FIG. 64).

In some embodiments, the spiral member 1609 can be biased toward the second expanded configuration shown in FIG. 63. The spiral member 1609 can then be moved by the locking member 1616 into the third configuration of FIG. 64. In other embodiments, the spiral member 1609 can be biased toward the third configuration shown in FIG. 64 such that the spiral member 1609 automatically moves into the third configuration after being moved outside the distal end of the outer delivery sheath 1663.

The locking member 1616 can include a collapsible sock portion 1629 that can be used to lock the spiral member 1609 in the third configuration as described in more detail below. More specifically, the locking member 1616 can define a lumen (not shown) configured to receive the inner tube 1619 such that the locking member 1616 can move distally along the inner tube 1619 as the push rod 1618 pushes the locking member 1616 distally relative to the outer delivery sheath 1663. Additionally, the push rod 1618 can define a lumen configured to receive the inner tube 1619 such that the push rod 1618 can travel over the inner tube 1619 as the push rod 1618 pushes the locking member 1616 and the spiral member 1609 distally through the outer delivery sheath 1663. The sock portion 1629 can be formed of, for example, a mesh or fabric material. The sock portion 1629 can be, for example, a Dacron sock. The sock portion 1629 is tubular shaped and can be moved from a first configuration during delivery of the epicardial pad 1639 in which the sock portion 1629 has a first length, to a second configuration in which the sock portion 1629 is at least partially collapsed upon itself and has a second shorter length than the first length. In the second configuration, the sock portion 1629 can engage at least some of the coils of the spiral member 1609 to maintain the spiral member 1609 in the third configuration (as shown in FIG. 64). Further, the material of the sock portion 1629 can maintain the sock portion 1629 in its second, collapsed configuration.

As described above for previous embodiments, a tether locking mechanism (not shown) can be used to lock the tether 1636 to the epicardial pad 1639. For example, when the tether 1636 is taut (e.g., when a desired tension on the tether has been achieved), the tether locking mechanism can

be configured to pin or lock the tether 1636 to the epicardial pad 1639. In some embodiments, the tether locking mechanism can be incorporated into the locking member 1616. Alternatively, the delivery device 1601 can include an extension element (not shown). The tether 1636 can be extended through the extension element. The extension element can be, for example, a tube, coil, or spring. The extension element can abut the locking member 1616 on the side of the locking member 1616 opposite the spiral member 1609 and extend proximally from the locking member 1616. The tether locking mechanism can be located on the proximal end of the extension element. In embodiments including the extension element, the tether locking mechanism can be located close to the skin of the patient after delivery of the spiral member 1609, providing easier access to the tether locking mechanism if a user (e.g., physician) desires to release the tether and remove the spiral member 1609 from the patient.

In some embodiments, the delivery device 1601 includes an inner delivery sheath (not shown). The spiral member 1609 in the first configuration can be movably disposed within the inner delivery sheath. The inner delivery sheath can be moved distally relative to the outer delivery sheath 1663 by rotating the inner delivery sheath such that the distal end of the inner delivery sheath extends beyond the distal end of the outer delivery sheath 1663. The rotation of the inner delivery sheath can assist in shaping the spiral member 1609 as it is being moved to the second and/or third configuration.

As shown in FIG. 62, the handle assembly 1617 can include a window with a scale. The window can be used to view the tether 1636. For example, the tether 1636 can extend through the handle assembly 1617 and include markings (not shown). For example, in some embodiments, the inner tube 1619 can be clear or transparent and extend through the handle assembly 1617 such that the markings on the tether 1636 are visible through the inner tube 1619. In some embodiments, the inner tube 1619 can include markings that are viewable through the window of the handle assembly 1617. The markings can be used to indicate the tautness or length of the tether 1636. The user can view the markings through the window to determine a condition of the tether 1636, such as the tautness. In some embodiments, the handle assembly 1617 can also include a tether locking device, such as for example a locking pin or vise type mechanism that can be used to hold the tether 1636 to the handle assembly 1617 during the delivery procedure. The handle assembly 1617 can also include a mechanism that can be used to increase or decrease the tension on the tether 1636.

In use, after a prosthetic mitral valve has been deployed within the heart H via a transfemoral approach (as described herein), a transapical approach, or another suitable delivery approach, the tether 1636 attached to the prosthetic valve (not shown) can extend outside the apex of the heart H and outside the patient's body via a small incision (similar to incision I as shown above in FIG. 48). The epicardial pad 1639 can be loaded into the outer delivery sheath 1663 to place the spiral member 1609 in the first configuration. A proximal end of the tether 1636 can be threaded into and through a distal end of the lumen of the inner tube 1619. The tether 1636 and the inner tube 1619 can then be threaded through the lumen 1613 of the outer delivery sheath 1663, through the center opening of the locking member 1616, and through the lumen of the stopper tube 1618. In this manner, the tether 1636 can provide a guide or otherwise assist in the insertion and movement of the outer delivery sheath 1663

through the incision in the skin of the patient. A distal end of the delivery sheath **1663** and a distal end of the inner tube **1619** can be moved along the tether **1636** and disposed at a desired location near the apex of the heart H. The distal end of the outer delivery sheath **1663** can be inserted through the

apex of the heart H such that the distal end is positioned between the epicardium E and the pericardium P of the heart H. When positioned between the epicardium E and the pericardium P, the distal end of the delivery sheath **1663** can be pulled proximally slightly to make room for the delivery of the epicardial pad **1639** (as shown in FIG. **62**). The stopper tube **1618** can then be moved relative to the outer delivery sheath **1663** to move the locking member **1616** distally relative to the outer delivery sheath **1663**, causing the locking member **1616** to move a portion of the spiral member **1609** out of the distal end of the outer delivery sheath **1663**. For example, the stopper tube **1618** can be moved distally along arrow AA relative to the outer delivery sheath **1663**, pushing the locking member **1616** and the spiral member **1609** distally. Alternatively, the outer delivery sheath **1663** can be pulled proximally relative to the stopper tube **1618** such that the distal end of the spiral member **1609** is released from the outer delivery sheath **1663**.

After the stopper tube **1618** has pushed the epicardial pad **1639** far enough distally, the spiral member **1609** can transition to its second configuration outside the apex of the heart H, as shown in FIG. **63**. The inner tube **1619** can then be retracted and the locking member **1616** can be pushed distally by the stopper tube **1618** such that the spiral member **1609** is moved into the third configuration (as shown in FIG. **64**), against the apex of the heart H. To secure the spiral member **1609** in its third configuration, the locking member **1616** can be moved to its second configuration (e.g., collapsed upon itself) to engage the coils of the spiral member **1609** as described above. The tether **1636** can be pulled taut (or to a desired tension) and secured to the epicardial pad **1639**. For example, one or more clips or one or more locking pins associated with the locking member **1616** can be used to secure the locking member **1616** to the tether **1636**. Alternatively, the tether **1636** can be tied such that the spiral member **1609** and the locking member **1616** are secured against the apex of the heart H. The stopper tube **1618** can then be disengaged from the locking member **1616** and retracted. In embodiments where the spiral member **1609** is biased towards the collapsed configuration, the stopper tube **1618** can be retracted prior to securing the spiral member **1609** and the tether **1636** in position relative to the tether **1636**.

FIGS. **65-70** illustrate an alternative method of delivering a prosthetic valve within an annulus of a heart via a transfemoral delivery approach. As shown in FIG. **65**, a procedural catheter **1735** is inserted through an apical puncture (e.g., a 5F apical puncture) in a ventricular wall at the apex Ap of the heart H. A guide wire **1737** is inserted through a lumen (not shown) of the procedural catheter **1735** and extended through the left ventricle LV, through a mitral valve gap and into the left atrium LA. A delivery sheath **1726** is introduced through a femoral vein puncture and extended through the inferior vena cava, into the right atrium, and then through a transeptal puncture of the septum Sp of the heart H, and into the left atrium LA of the heart H. A snare device **1728** is movably disposed within the delivery sheath **1726** and used to grab or snare a distal end portion of the guide wire **1737**, as shown in FIG. **65**. The snare device **1728** can be used to pull the guide wire **1737** through the delivery sheath **1726** such that the distal end portion of the guide wire

1737 extends outside the femoral vein and a proximal end of the guide wire **1737** is disposed through the ventricular wall at the apex Ap of the heart H, as shown in FIG. **44**. Although not shown in FIGS. **43** and **44**, the procedural catheter **1735** is disposed outside the patient's body, the distal end of the guide wire **1737** extends outside the femoral vein and outside the patient's body, and the proximal end of the guide wire **1737** extends outside the apex Ap and outside the patient's body. Although the above described snare process describes delivering the guide wire **1737** to the left atrium of the heart and then snaring the guide wire **1737** using the snare device **1728**, in alternative embodiments, the guide wire **1737** can be delivered to the left ventricle LV and the snare device **1728** and delivery sheath **1726** can be inserted through the mitral annulus and into the left ventricle LV to grab or snare the guide wire **1737** as described above.

After the guide wire **1737** has been extended between the apex Ap and the access site to the femoral vein, the delivery sheath **1726** can be removed. A leader tube **1724** is loaded over the guide wire **1737** starting outside the heart (and outside the procedural catheter **1735**) and exiting the femoral vein at the femoral puncture site as shown in FIG. **45**. As shown in FIG. **45**, the leader tube **1724** includes a balloon dilator member **1711** that is inserted into a distal end of the delivery sheath **1726** and disposed partially over a distal end portion of the prosthetic valve **1700**. For example, the balloon dilator member **1711** can have a collapsed or uninflated configuration (not shown) for delivery over the guide wire **1737** and can then be inflated or otherwise moved to an expanded configuration as shown in FIG. **45**. Also shown in FIG. **45**, a pusher **1738** is disposed within the lumen of the delivery sheath **1726** and can be used to move or push the prosthetic valve **1700** into the left atrium LA, as described in more detail below. With the leader tube **1724** disposed between the femoral puncture site and the apex of the heart, the guide wire **1737** can be removed. Although not shown in FIGS. **45-47**, the procedural catheter **1735** remains inserted into the left ventricle LV of the heart as shown in FIGS. **43** and **44**.

The prosthetic valve **1700** can be configured the same as or similar to the prosthetic valves described herein. The prosthetic valve **1700** (shown schematically within the delivery sheath **1726** in FIG. **45**) can be disposed in an inverted configuration within the delivery sheath **1726** to reduce the overall outer perimeter of the prosthetic valve **1700**. A tether **1736** is coupled to a distal end portion of the prosthetic valve **1700** (see FIGS. **47** and **48**). The tether **1736** can be threaded through the leader tube **1724** prior to the leader tube **1724** being disposed within the distal end of the delivery sheath **1726**. For example, as previously described, the tether **1736** can include a valve leader member (not shown). The valve leader member can have a tapered distal end to aid in the insertion and maneuvering of the valve leader member through the leader tube **1724**. The valve leader member can be attached at a proximal end portion of the tether **1736**, which is attached to the valve **1700**. The tether **1736** can be formed, for example, as a braided rope or cord. The tether **1736** can be threaded through the leader tube **1724** with the valve leader member extended out the apex of the proximal end of the leader tube **1724** outside the apex of the heart. Thus, the tether **1736** extends between the apex Ap and the femoral puncture site where it is coupled to the valve **1700**.

The delivery sheath **1726** can then be inserted through the femoral puncture site and moved through the femoral vein, through the inferior vena cava, into the right atrium, and then through the septum Sp until a distal end portion of the

delivery sheath **1726** (with the valve **1700**) is disposed within the left atrium LA, as shown in FIG. **46**. The dilator balloon member **1711** can provide a smooth lead-in to assist in maneuvering the distal end of the delivery sheath **1726** through the femoral vein and within the heart. Although the delivery sheath **1726** is used to deliver both the snare device **1728** and the valve **1700**, in other embodiments, a different delivery sheath can be used to deliver the snare device **1728** than is used to deliver the valve **1700**.

With the distal end of the delivery sheath **1726** within the left atrium LA, the leader tube **1724** can be removed through the apex Ap, leaving the tether **1736** extended between the valve **1700** and outside the apex Ap of the heart (see FIG. **47**). For example, the balloon dilator member **1711** can be moved back to a collapsed configuration for removal through the procedural catheter **1735**. The procedural catheter **1735** can then also be removed. The pusher **1738** can be used to push or move the valve **1700** out the distal end of the delivery sheath **1726** and within the left atrium LA of the heart as shown in FIG. **47**. As the valve exits the distal end of the delivery sheath **1726** the valve **1700** can revert and return to its original undeformed shape as described above, for example, for valve **200**. For example, the valve **1700** can be formed with a shape-memory material and can have a biased undeformed shape and can be manipulated and/or deformed (e.g., compressed and/or expanded) and, when released, return to its original undeformed shape. The valve can be, for example, a valve constructed the same as or similar to, and function in the same or similar manner as, the prosthetic heart valve **200**, described above.

As shown in FIG. **47**, the tether **1736** extends from the valve **1700** through the apical puncture and outside the patient's body. As the delivery sheath **1726** is advanced, the tether **1736** can optionally be pulled at the apex end to help move the delivery sheath **1726**, with the valve **1700** disposed therein, through the femoral vein, through the septal puncture and into the left atrium LA. The valve **1700** can then be fully deployed within the left atrium LA, as shown in FIG. **48**, by using the pusher **1738** described above and/or by pulling the apex end portion of the tether **1736** until the valve **1700** is pulled out of the lumen of the delivery sheath **1726** and disposed within the left atrium LA.

In some embodiments, the pusher **1738** can also be used to aid in positioning the valve **1700** in a desired radial orientation within the left atrium LA. For example, the pusher device **1738** can define an internal lumen (not shown) that can be placed over an inner frame portion of the valve **1700** to hold the inner frame portion in a small diameter, which can help enable the valve **1700** to be positioned in a desired radial orientation and be seated within the annulus of the mitral valve. Further examples of such a valve assist device are described below with reference to FIGS. **49-51**.

As shown in FIG. **48**, as the valve **1700** is deployed within the left atrium LA, the valve **1700** is allowed to assume its biased expanded or deployed configuration. The delivery sheath **1726** can then be removed from the patient and the valve **1700** can be positioned and tensioned using the tether **1736** to obtain the desired or optimal location in the native mitral annulus and minimize perivalvular leaks. An epicardial pad device **1739** (as described above) can be used to secure the tether **1736** and valve **1700** in position within the mitral annulus. In some embodiments, rather than securing the prosthetic mitral valve with a tether and epicardial pad, the prosthetic mitral valve can be secured with clips or other coupling methods to a portion(s) of the mitral valve apparatus and/or the ventricular wall of the heart.

Although not shown for all embodiments, any of the embodiments of a delivery device or system can include a handle or handle assembly to which the various delivery sheaths and components can be operatively coupled and which a user (e.g., physician) can grasp and use to manipulate the delivery device or system. For example, the handle assembly can include controls to move the various delivery sheaths and other components.

In addition, the systems and methods described herein can also be adapted for use with a prosthetic tricuspid valve. For example, in such a case, a procedural catheter can be inserted into the right ventricle of the heart, and the delivery sheath delivered to the right atrium of the heart either directly (transatrial), or via the jugular or femoral vein. In such a case, the delivery devices to deliver an epicardial pad can be disposed outside the heart below the right ventricle and/or be inserted within the right ventricle depending on the particular embodiment of the epicardial pad being delivered.

While various embodiments have been described above, it should be understood that they have been presented by way of example only, and not limitation. Where methods described above indicate certain events occurring in certain order, the ordering of certain events may be modified. Additionally, certain of the events may be performed concurrently in a parallel process when possible, as well as performed sequentially as described above.

Where schematics and/or embodiments described above indicate certain components arranged in certain orientations or positions, the arrangement of components may be modified. While the embodiments have been particularly shown and described, it will be understood that various changes in form and details may be made. Any portion of the apparatus and/or methods described herein may be combined in any combination, except mutually exclusive combinations. The embodiments described herein can include various combinations and/or sub-combinations of the functions, components, and/or features of the different embodiments described.

What is claimed is:

1. An apparatus, comprising:

an epicardial pad configured to engage an outside surface of a heart to secure a prosthetic heart valve in position within the heart, the prosthetic heart valve having a tether extending therefrom and outside the heart when the prosthetic heart valve is disposed within the heart, the epicardial pad defining a lumen configured to receive the tether therethrough,

the epicardial pad being movable between a first configuration in which the epicardial pad has a first outer perimeter and is configured to be disposed within a lumen of a delivery sheath and a second configuration in which the epicardial pad has a second outer perimeter greater than the first outer perimeter,

the epicardial pad configured to be disposed against the outside surface of the heart when in the second configuration to secure the prosthetic valve and tether in a desired position within the heart,

wherein the epicardial pad is a balloon.

2. The apparatus of claim 1, wherein the balloon is configured to be inflated by an inflation medium to move the epicardial pad to the second configuration.

3. The apparatus of claim 1, wherein the balloon is configured to be inflated by an inflation medium to move the epicardial pad to a third configuration in which the epicardial pad is expanded,

the epicardial pad configured to be moved from the third configuration to the second configuration in which the epicardial pad is collapsed inwardly to form a cup shape.

4. The apparatus of claim 1, wherein the balloon includes an inflation lumen through which an inflation medium can be communicated to and from the balloon. 5

5. The apparatus of claim 4, wherein the inflation lumen is defined by the balloon.

6. The apparatus of claim 4, wherein the inflation lumen is defined by an inflation line separate from the balloon and in fluid communication with an interior of the balloon. 10

* * * * *