



US 20060151588A1

(19) **United States**

(12) **Patent Application Publication**
Mikolajczyk et al.

(10) **Pub. No.: US 2006/0151588 A1**

(43) **Pub. Date: Jul. 13, 2006**

(54) **CLUSTER BOX MAIL DELIVERY UNIT
HAVING SECURITY FEATURES**

(52) **U.S. Cl. 232/24**

(76) Inventors: **Ryszard K. Mikolajczyk**, Chicago, IL
(US); **Taurris D. Baskerville**,
Schaumburg, IL (US)

(57) **ABSTRACT**

Correspondence Address:
**FINNEGAN, HENDERSON, FARABOW,
GARRETT & DUNNER
LLP**
901 NEW YORK AVENUE, NW
WASHINGTON, DC 20001-4413 (US)

An apparatus and method for enhancing the security of a cluster box unit which includes a protective enclosure, internal cabinetry, door, hinge and locking system. The cluster box unit may also include outgoing mail compartment doors that are heavily constructed and rigidly reinforced, with the locks carried thereon protectively shielded, and with the extensible bolts of these locks being engaged by brackets that not only lock the outgoing mail compartment doors but also the master loading doors of the cluster box units. The cluster box unit may also include master loading doors are provided with hinges that extend the full height of the doors—hinges that are defined by pivotally interfitting elements of extrusions that very sturdily mount the master loading doors, that prevent prying or bending the doors in the vicinities of their hinges. The interfitting elements of the hinge extrusions also permit the doors to be installed on their surrounding door frames quickly and easily, and permit one or both of the master loading doors to be quickly and easily removed for service or replacement when necessary.

(21) Appl. No.: **11/168,302**

(22) Filed: **Jun. 29, 2005**

Related U.S. Application Data

(60) Provisional application No. 60/583,419, filed on Jun. 29, 2004.

Publication Classification

(51) **Int. Cl.**
A47G 29/12 (2006.01)

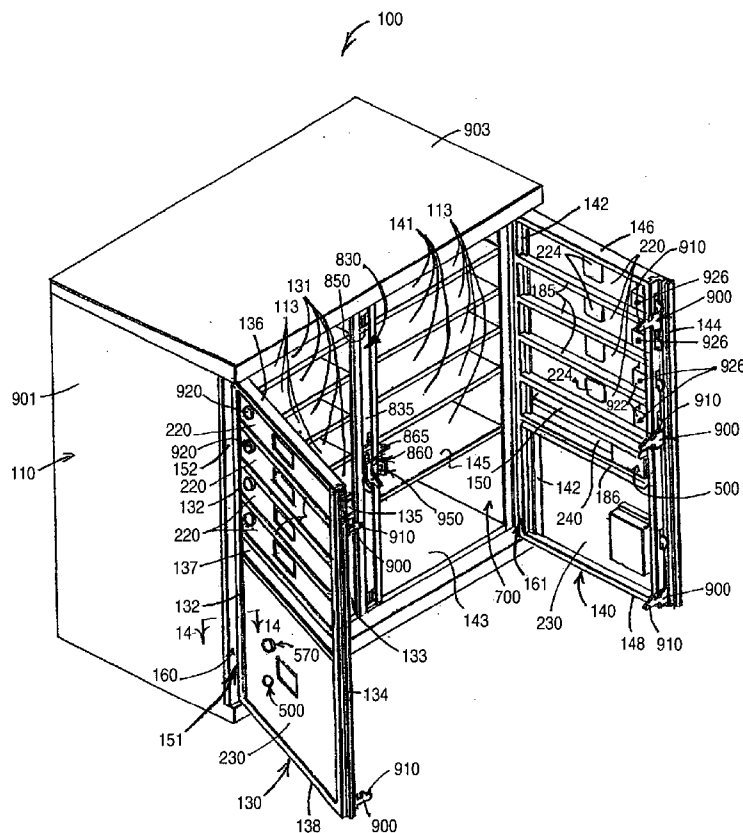

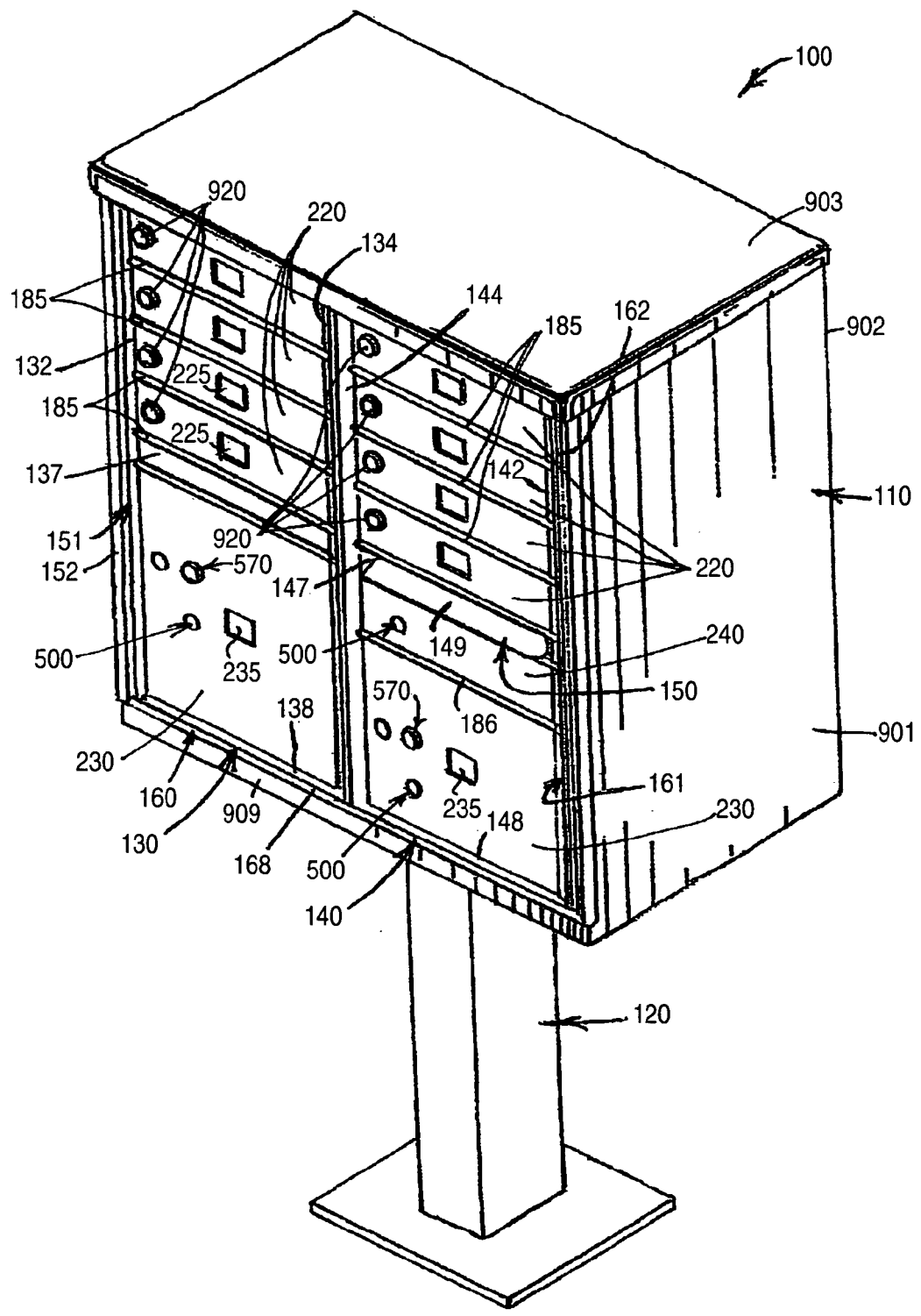

FIG. 1

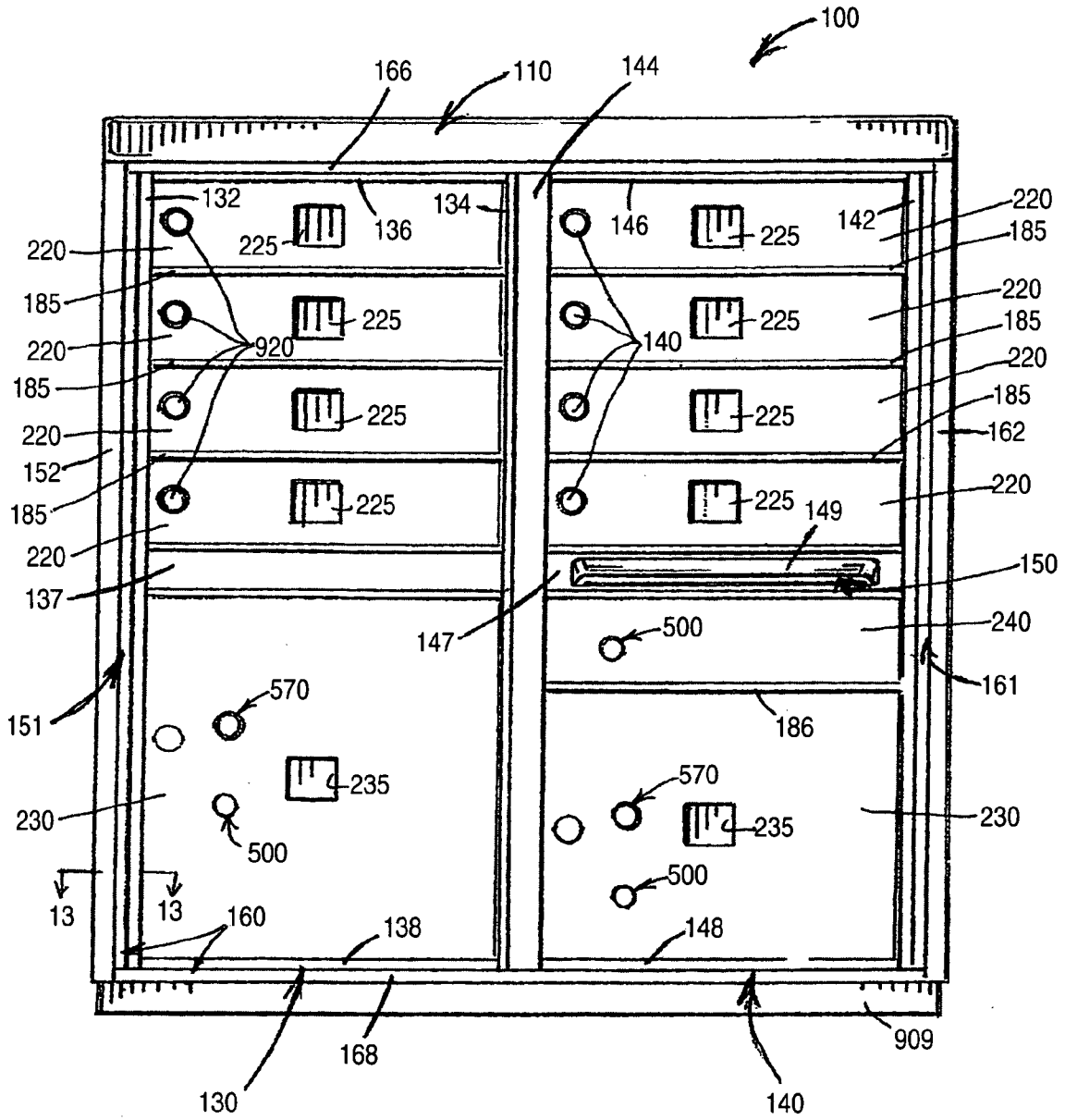

FIG. 2

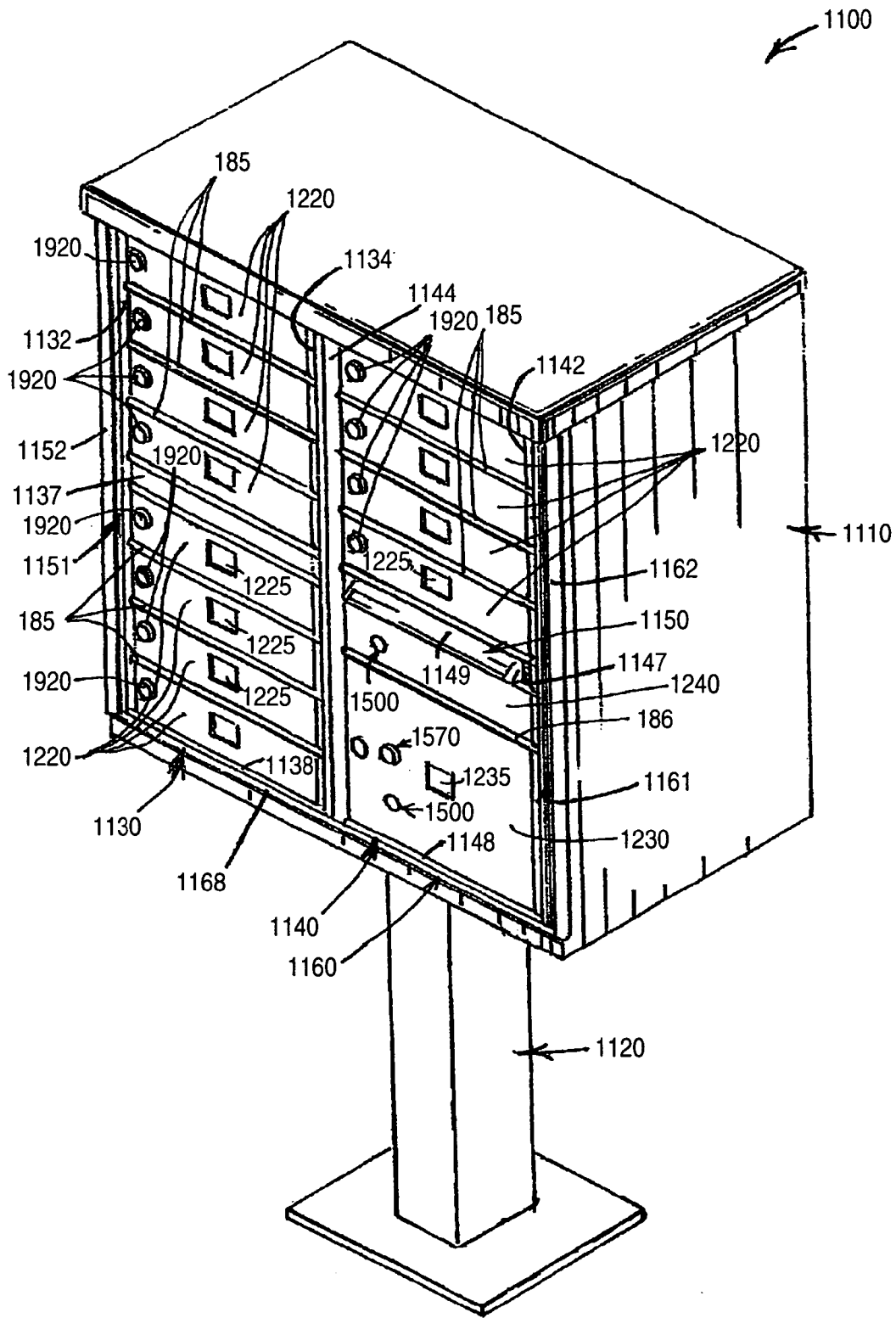

FIG. 3

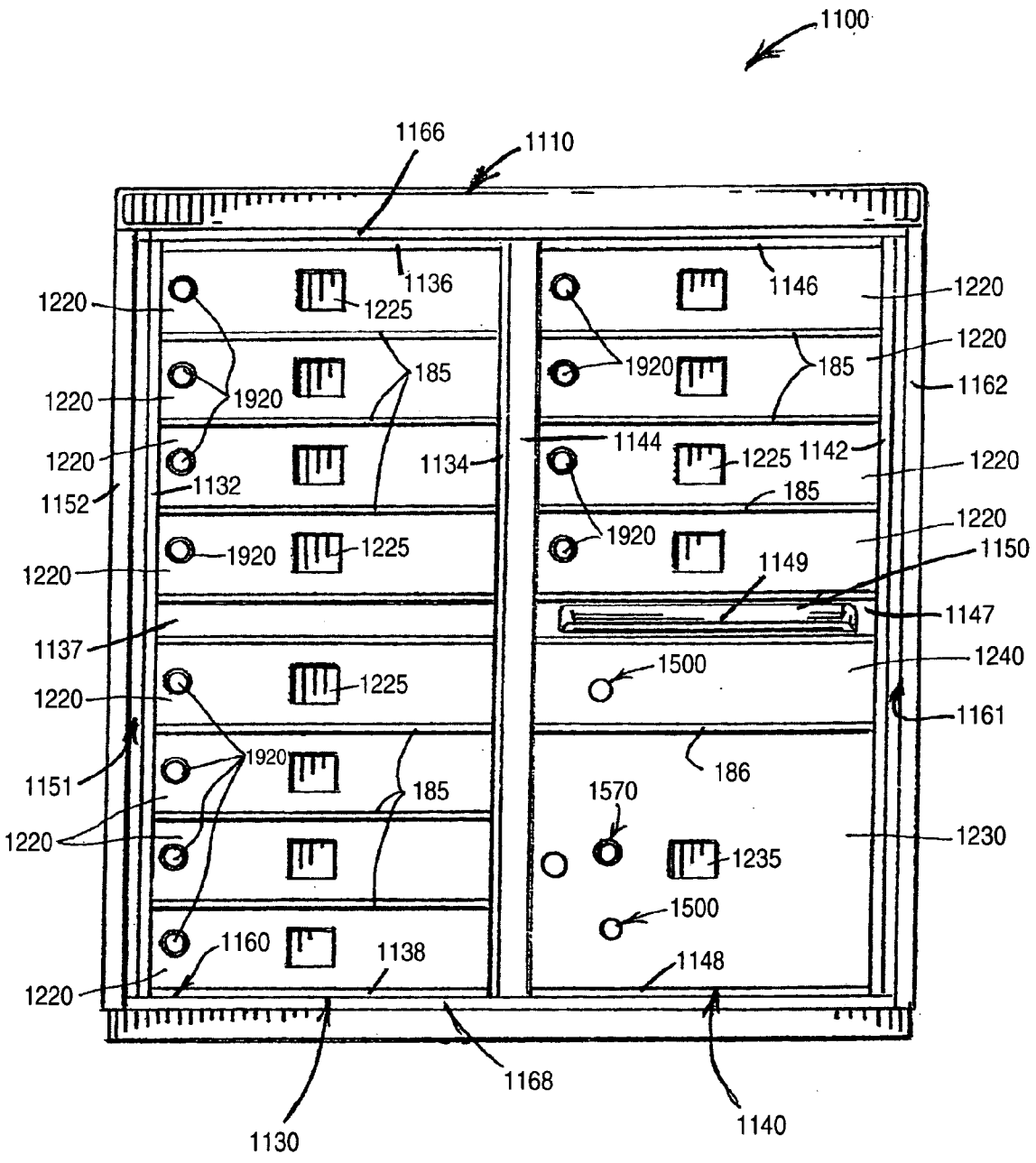

FIG. 4

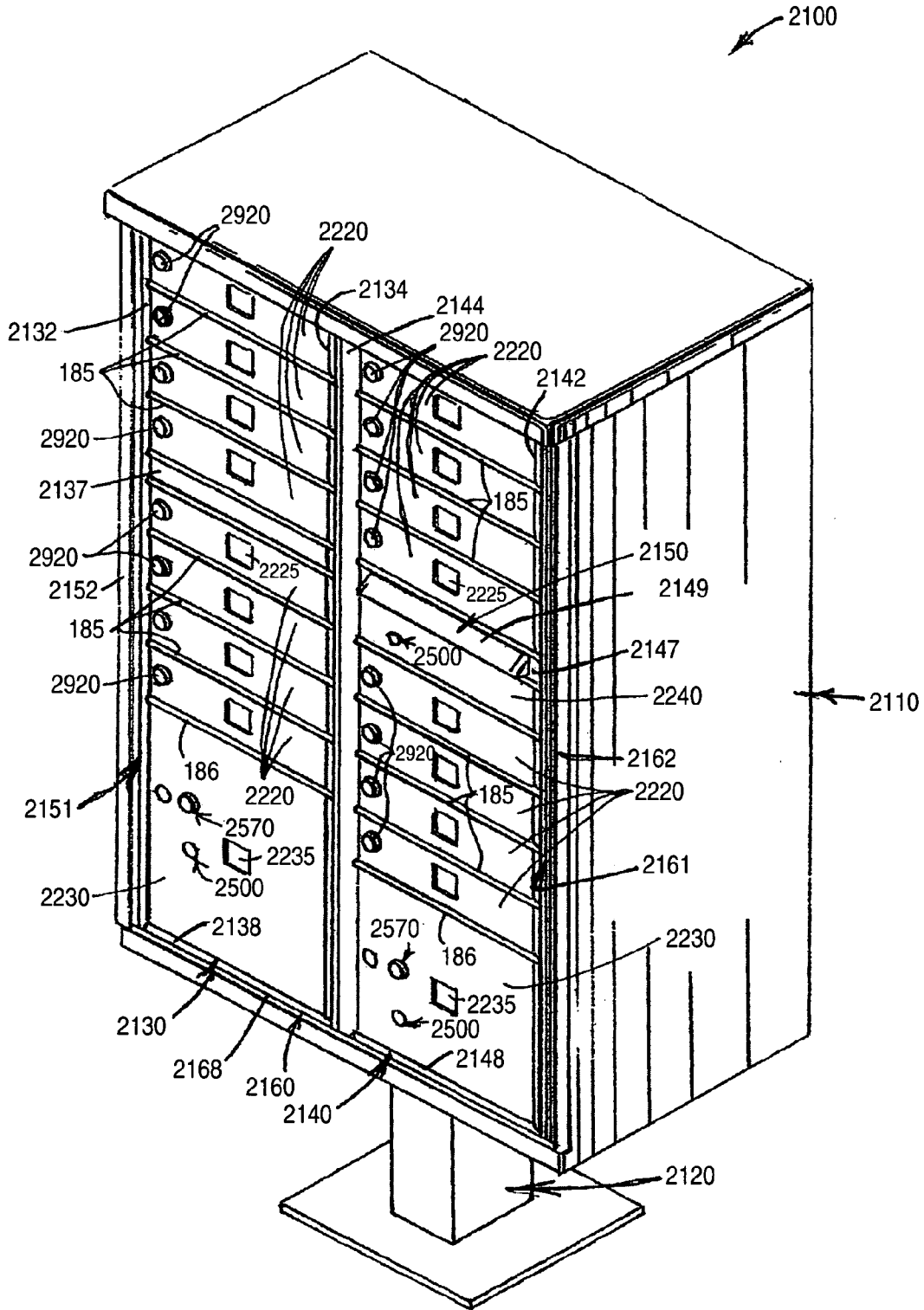

FIG. 5

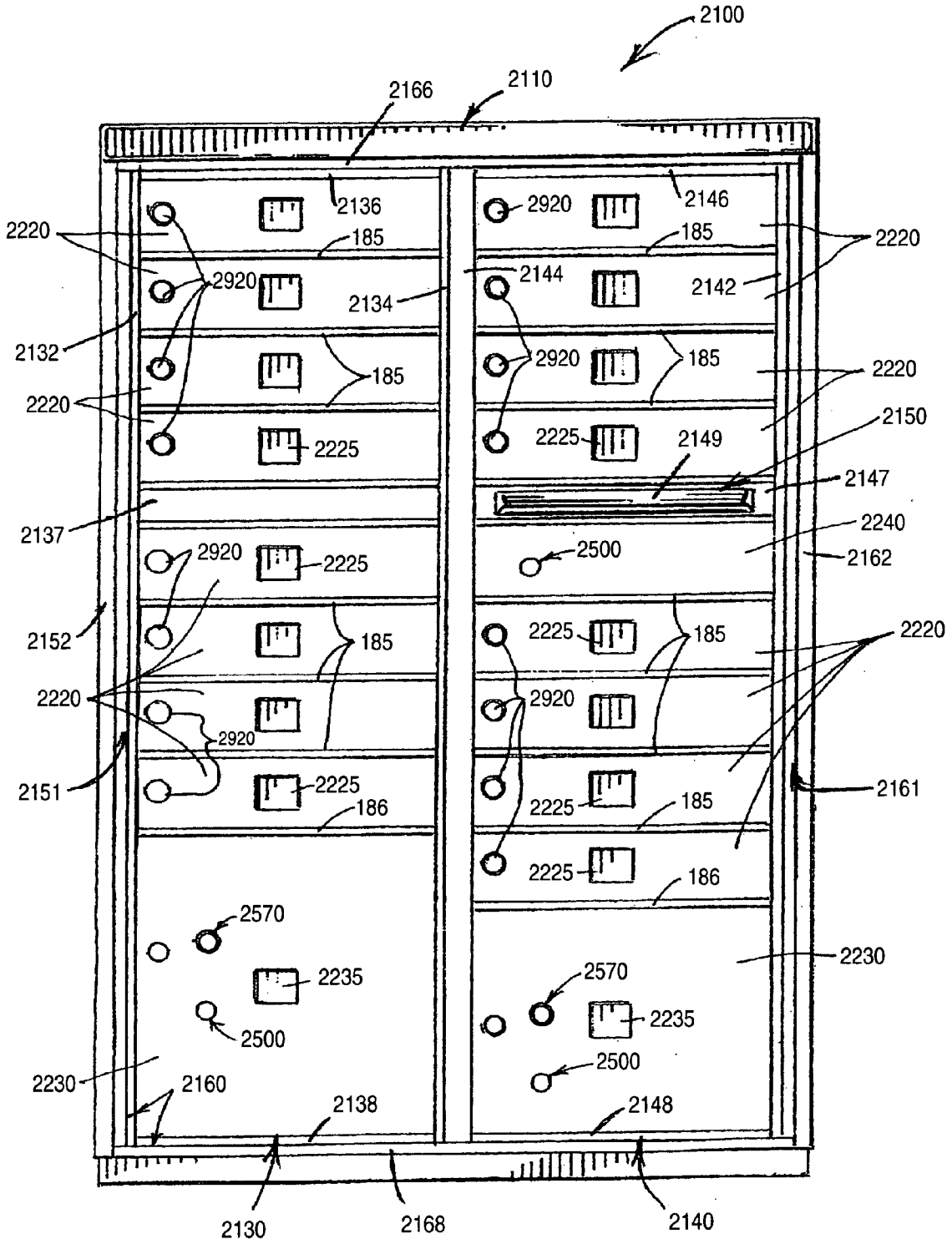

FIG. 6

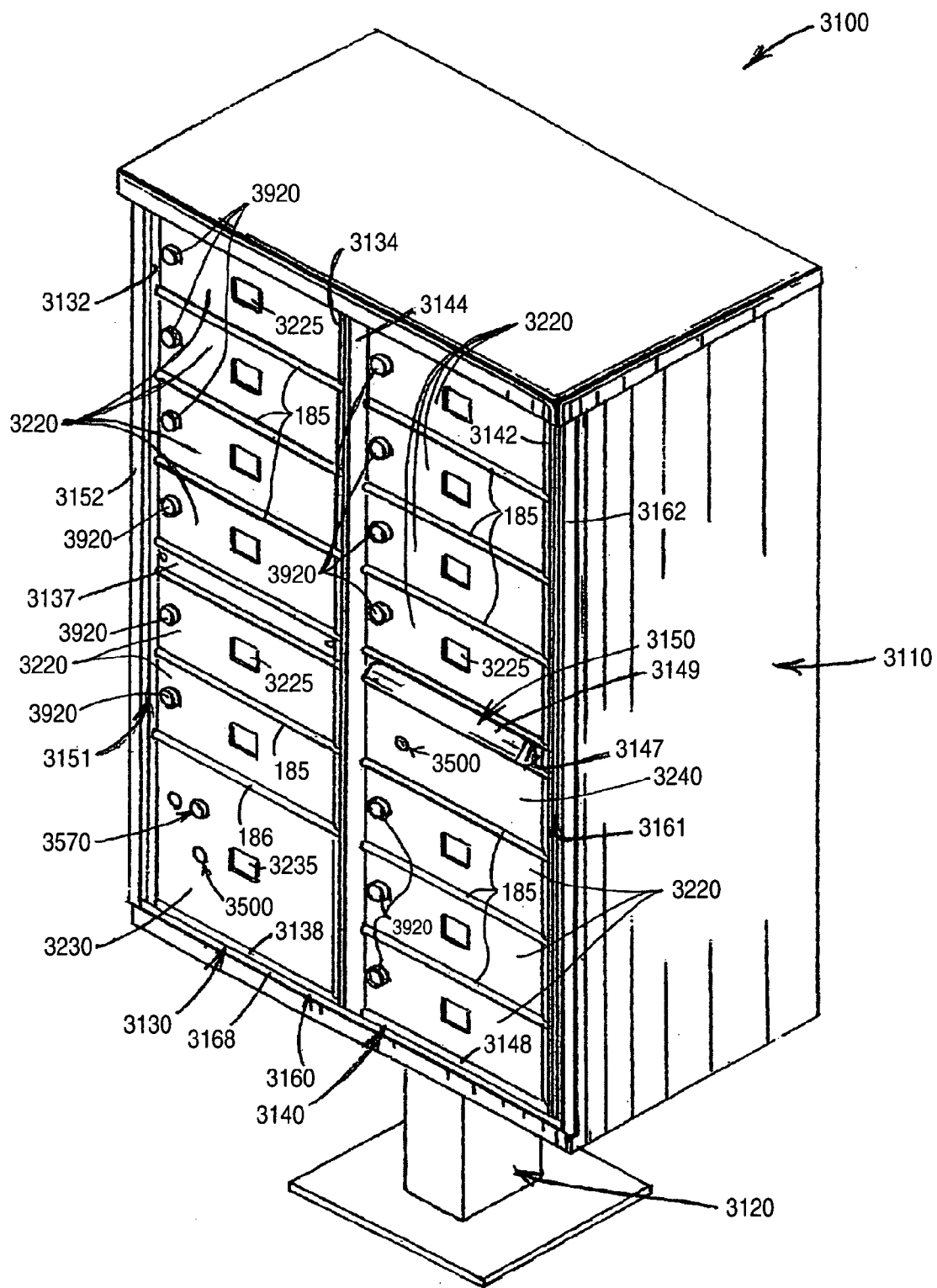
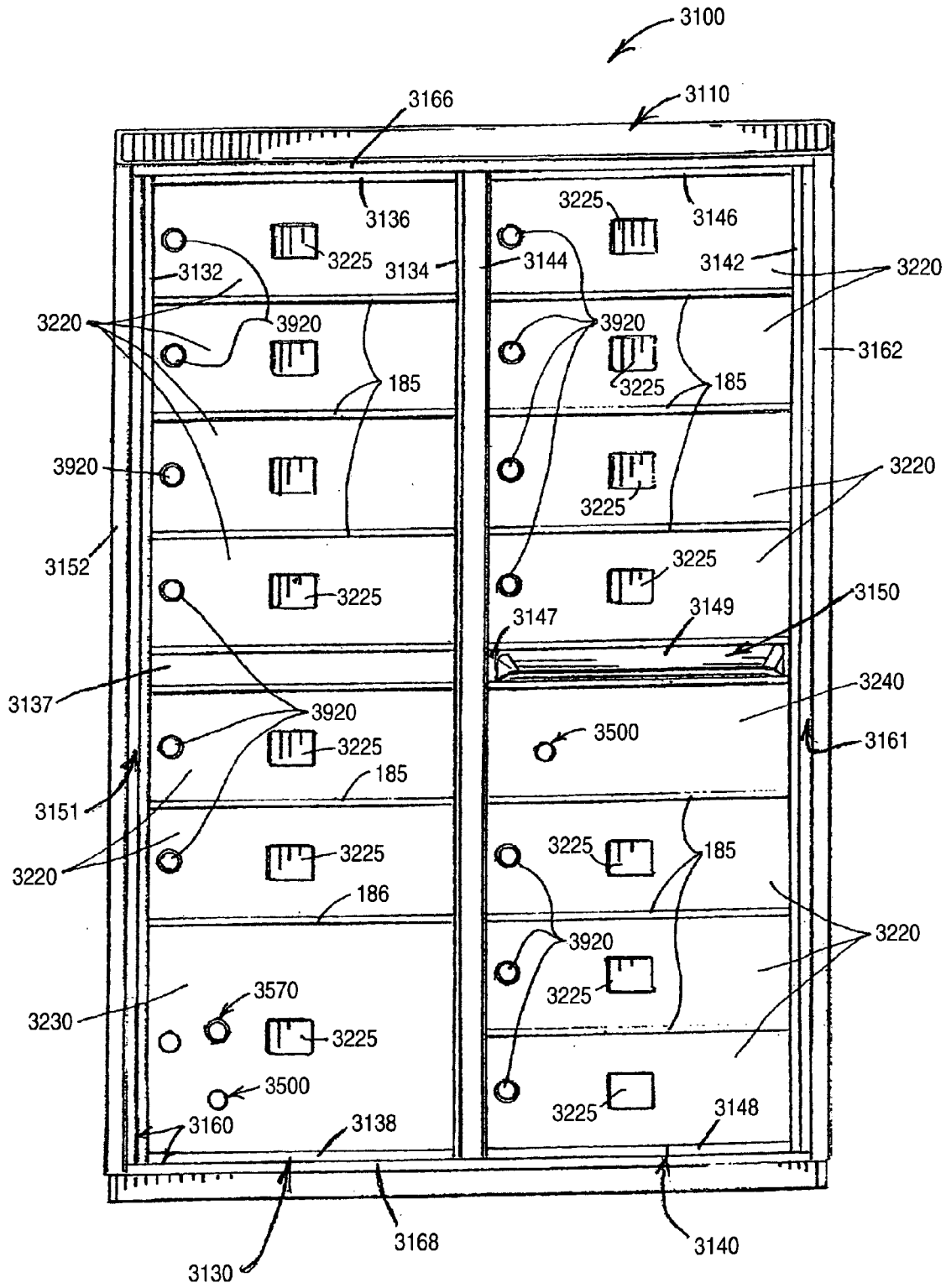

FIG. 7



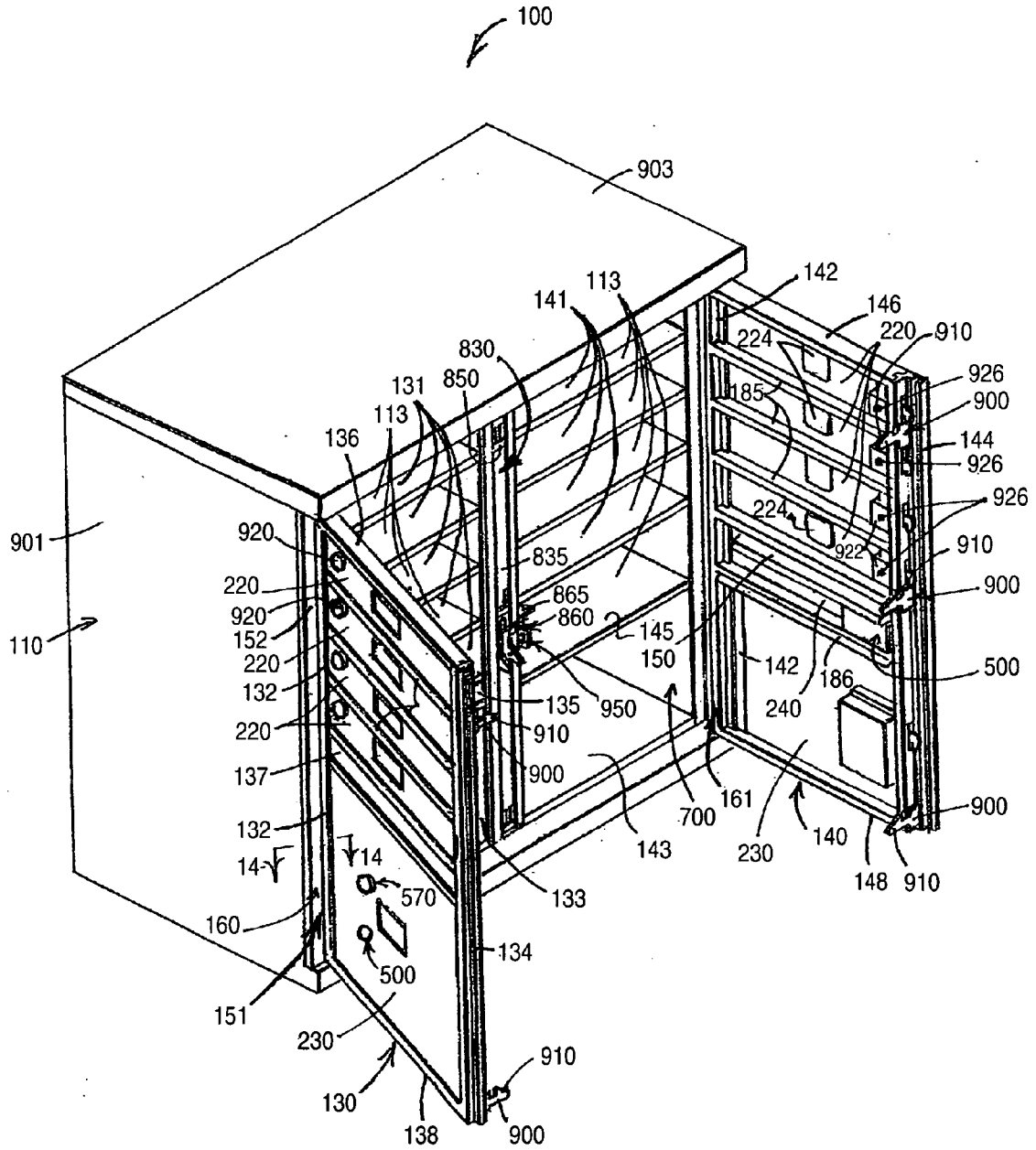

FIG. 9

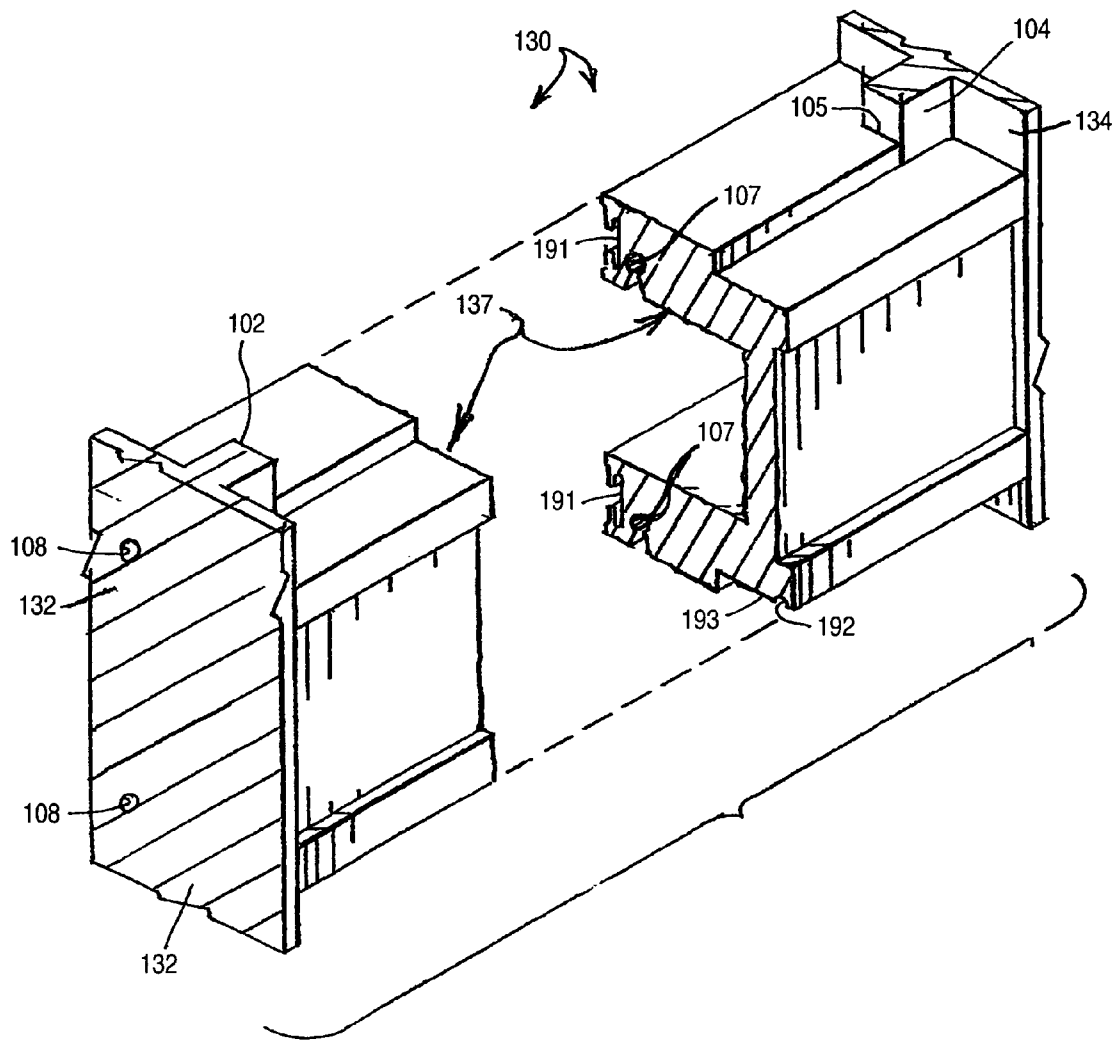

FIG. 10

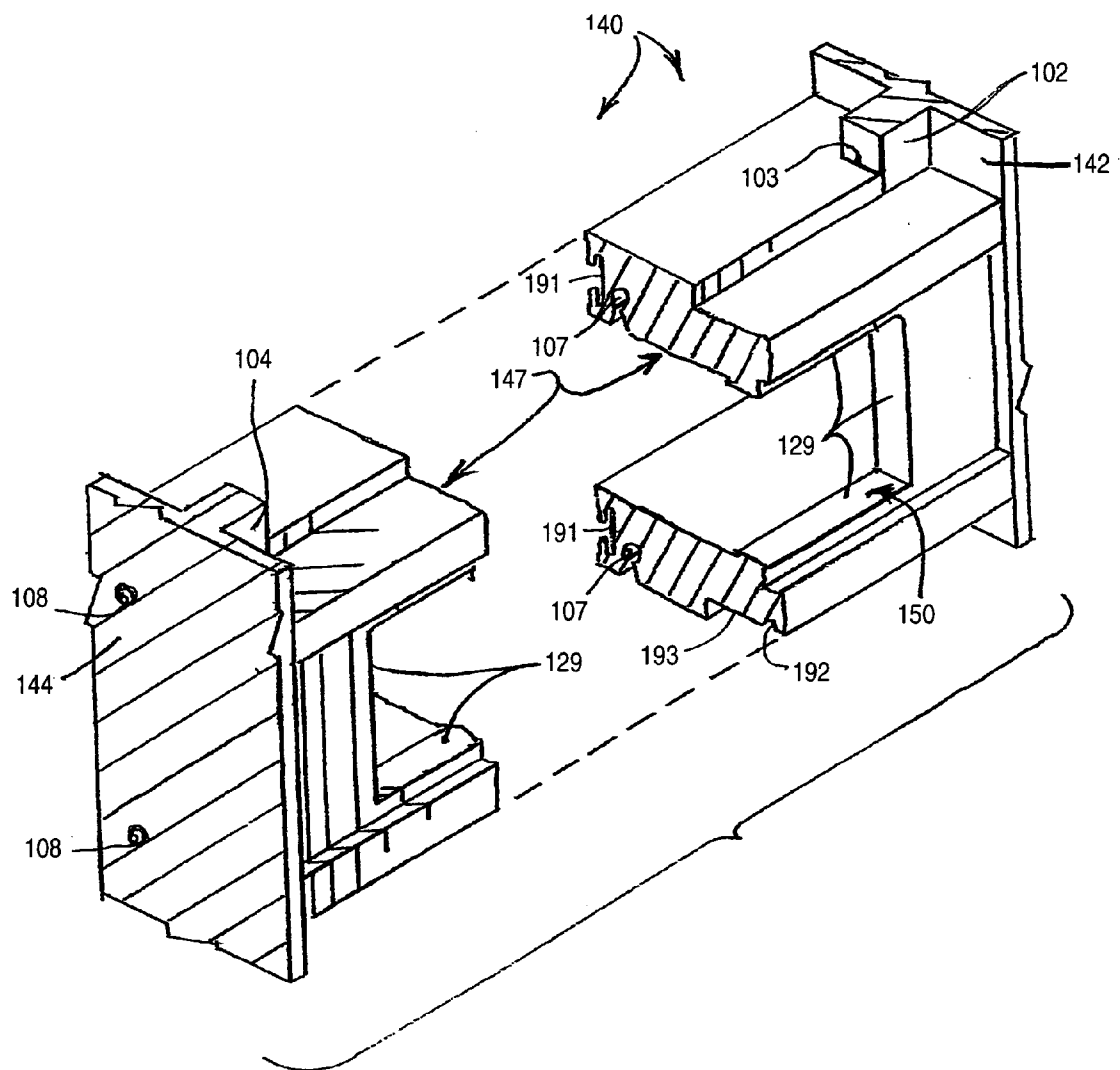

FIG. 11

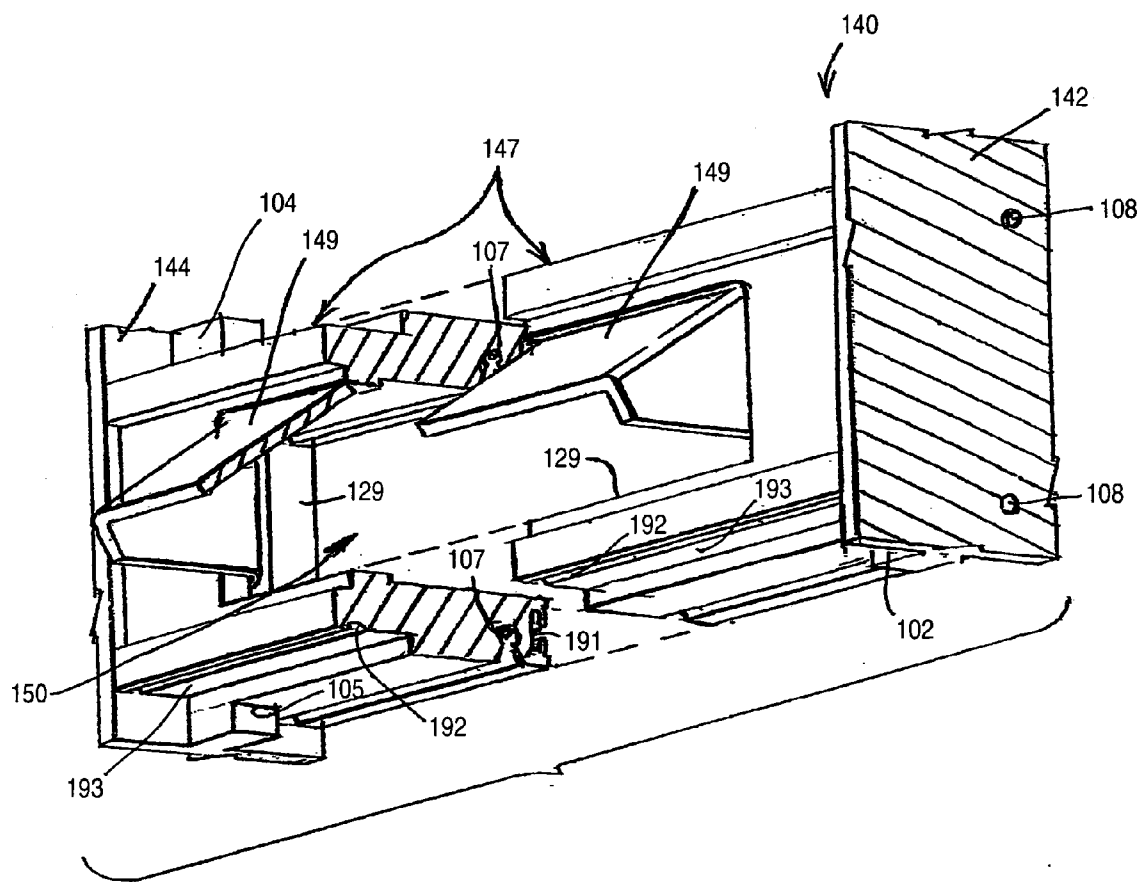

FIG. 12

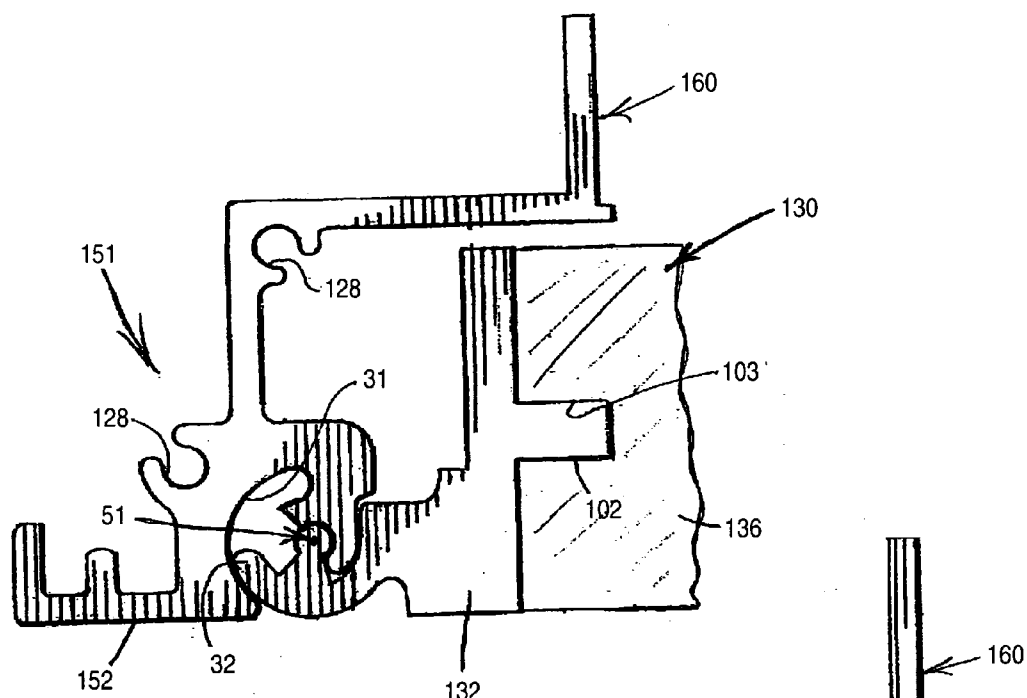

FIG. 13

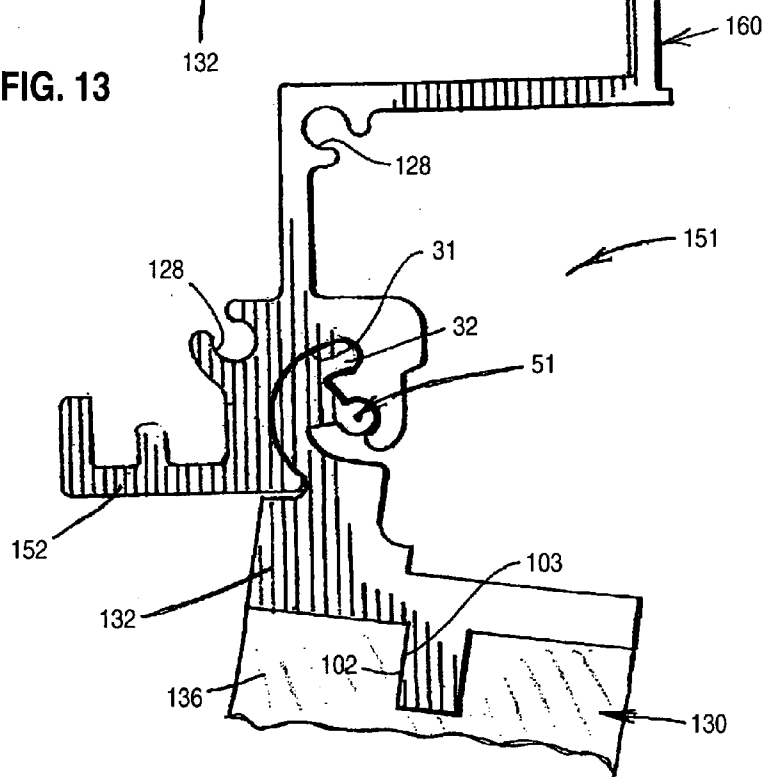

FIG. 14

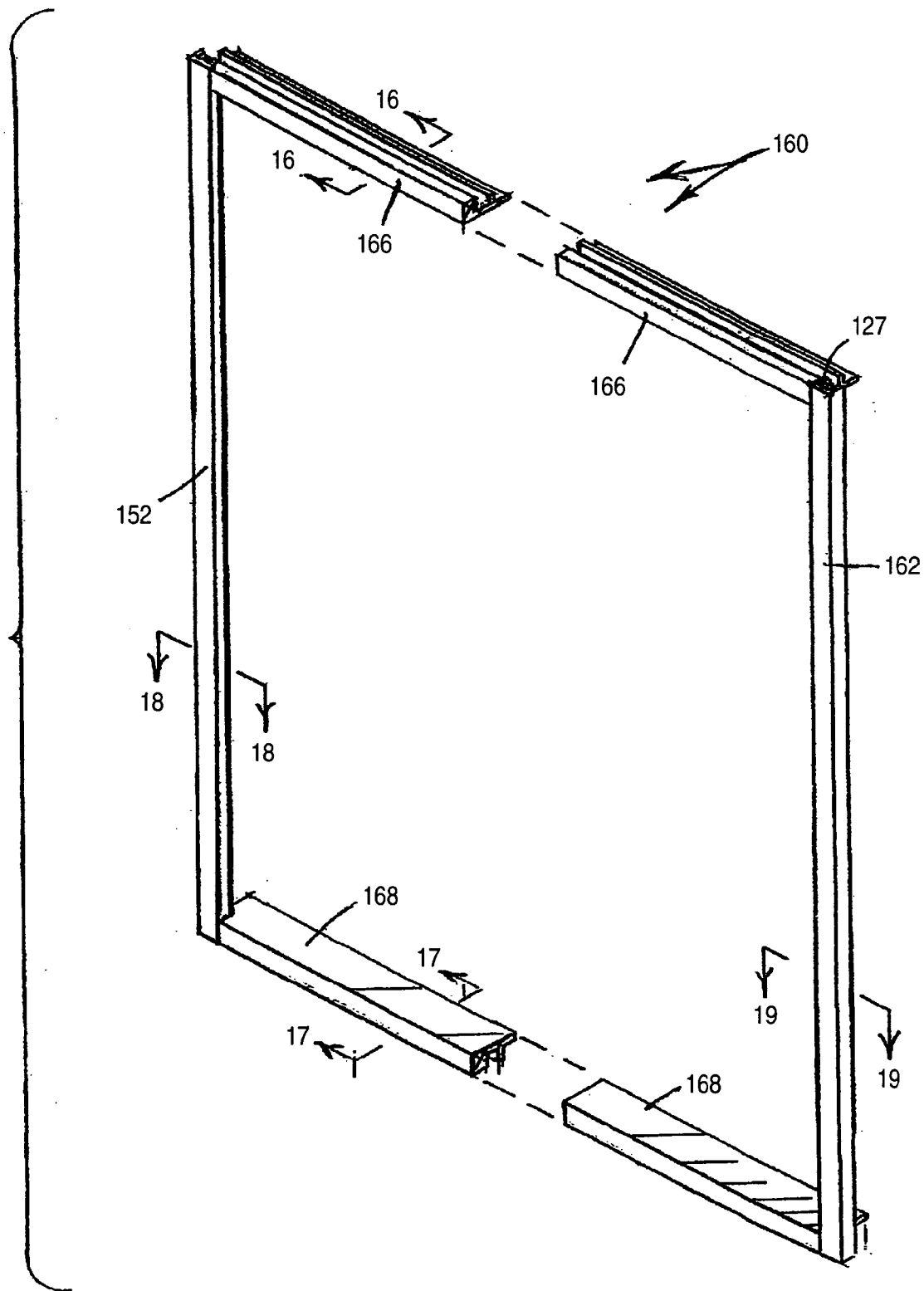

FIG. 15

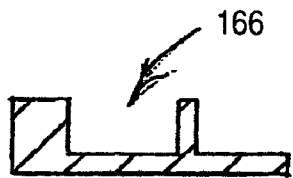

FIG. 16

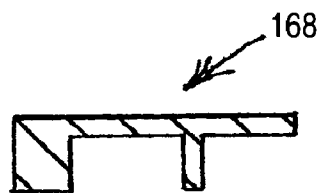

FIG. 17

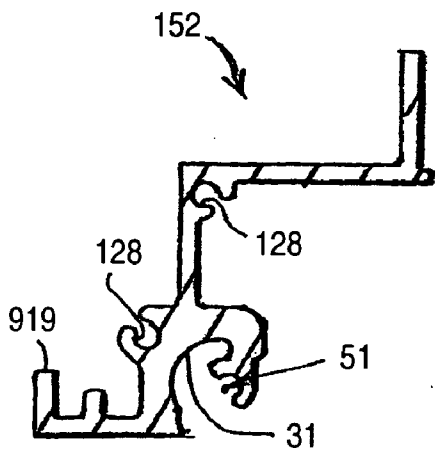

FIG. 18

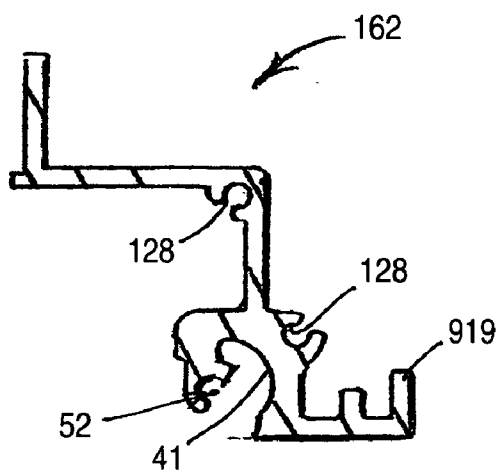

FIG. 19

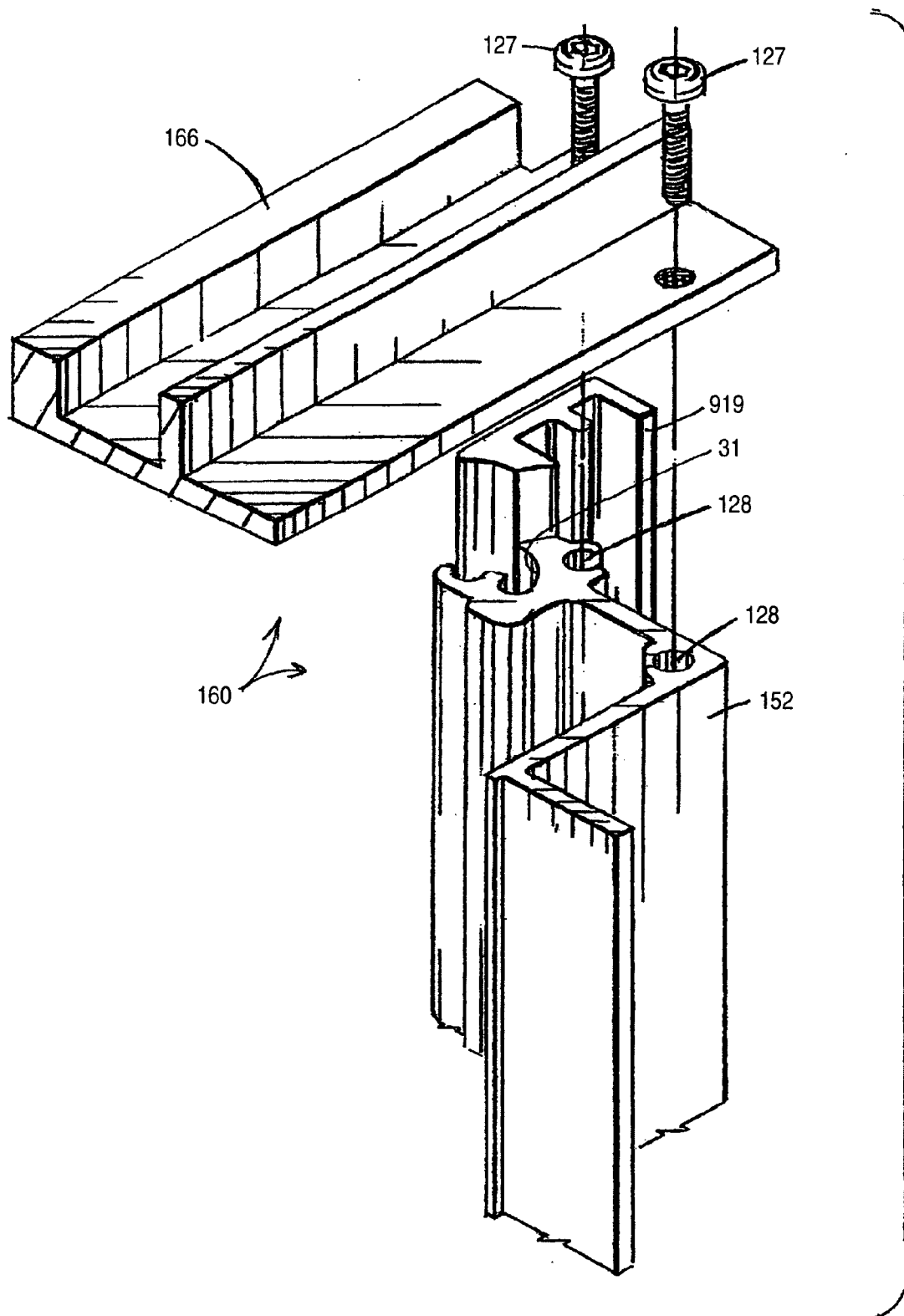

FIG. 20

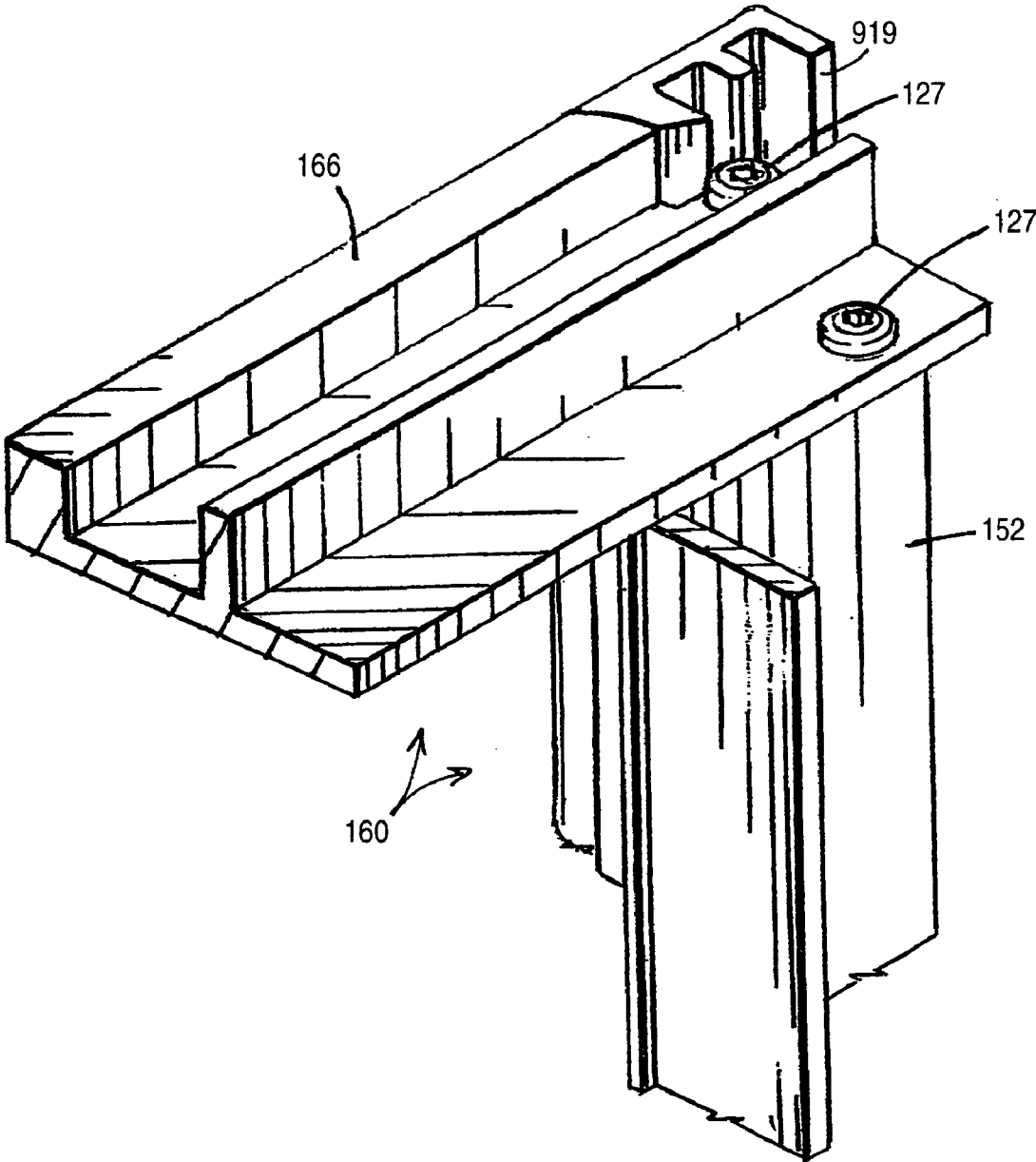

FIG. 21

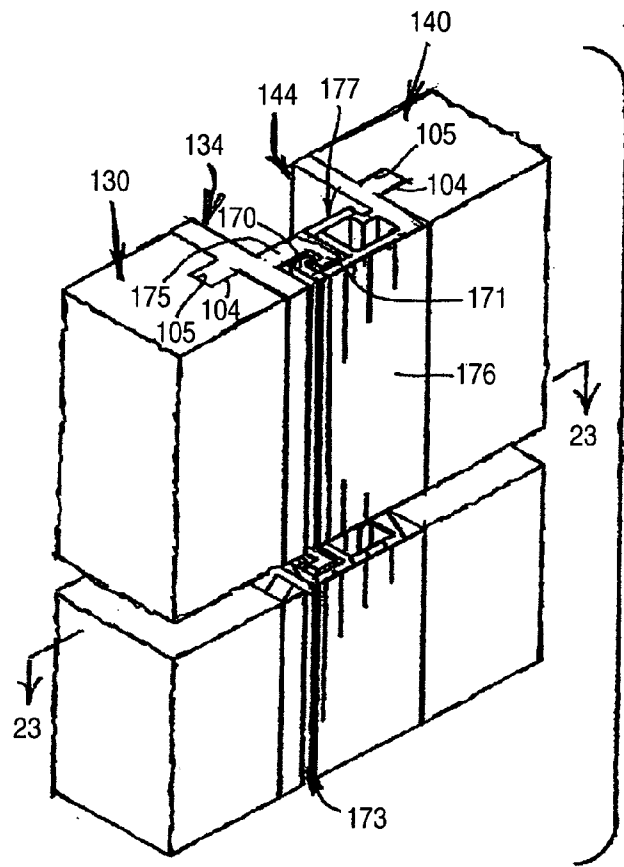

FIG. 22

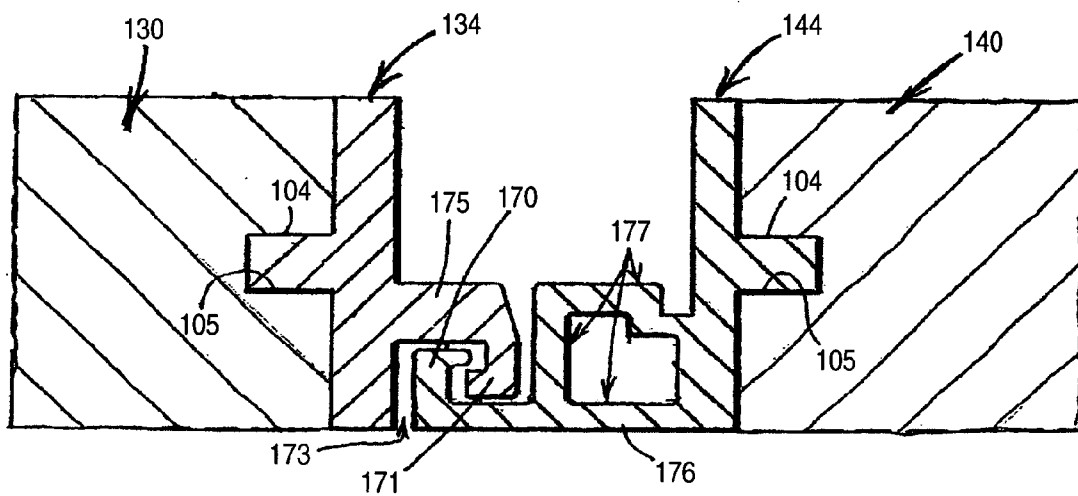

FIG. 23

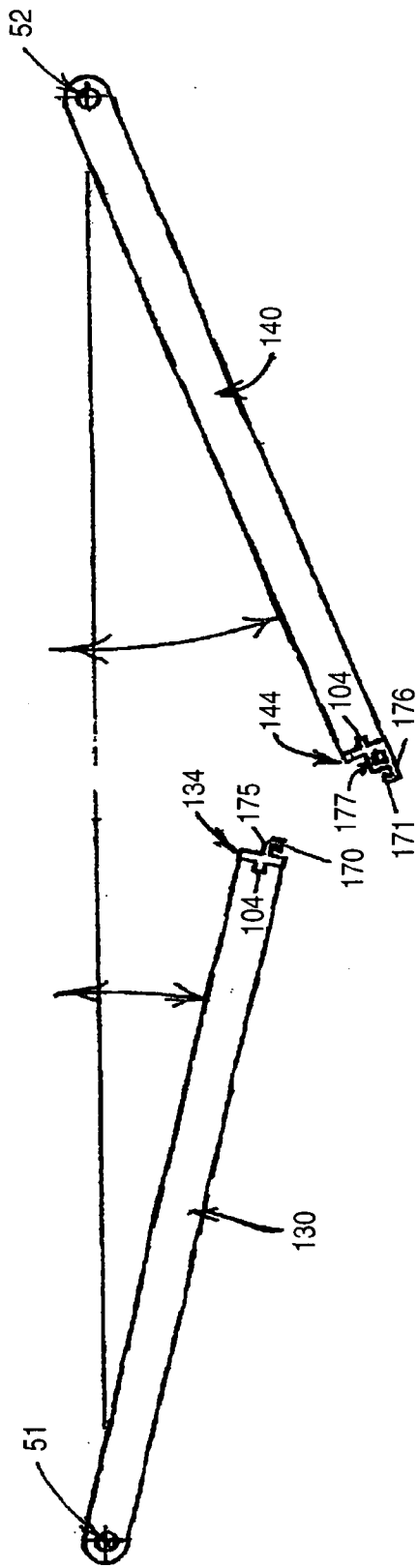

FIG. 24

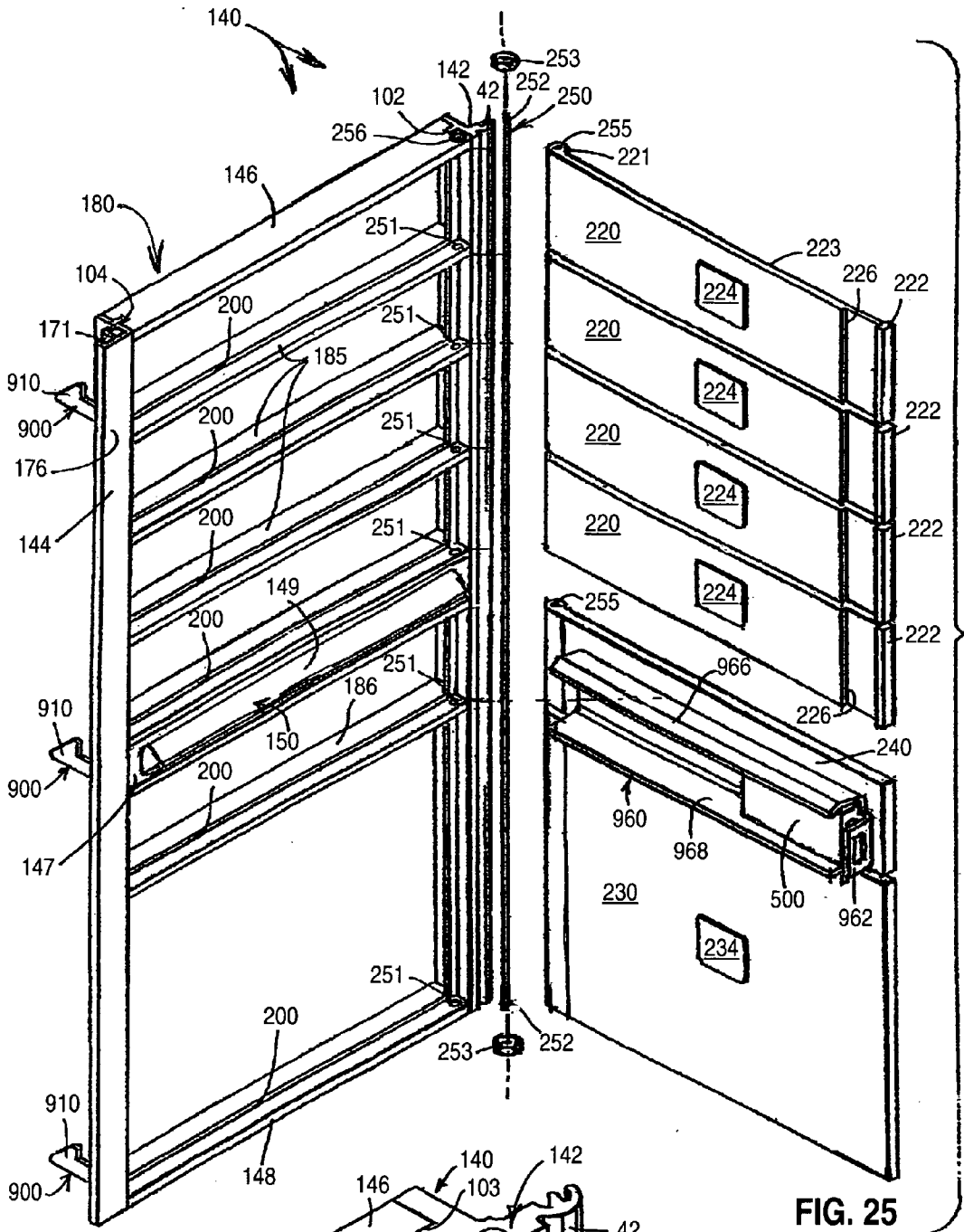

FIG. 25

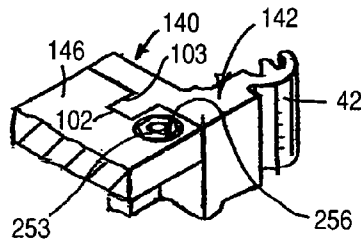

FIG. 26

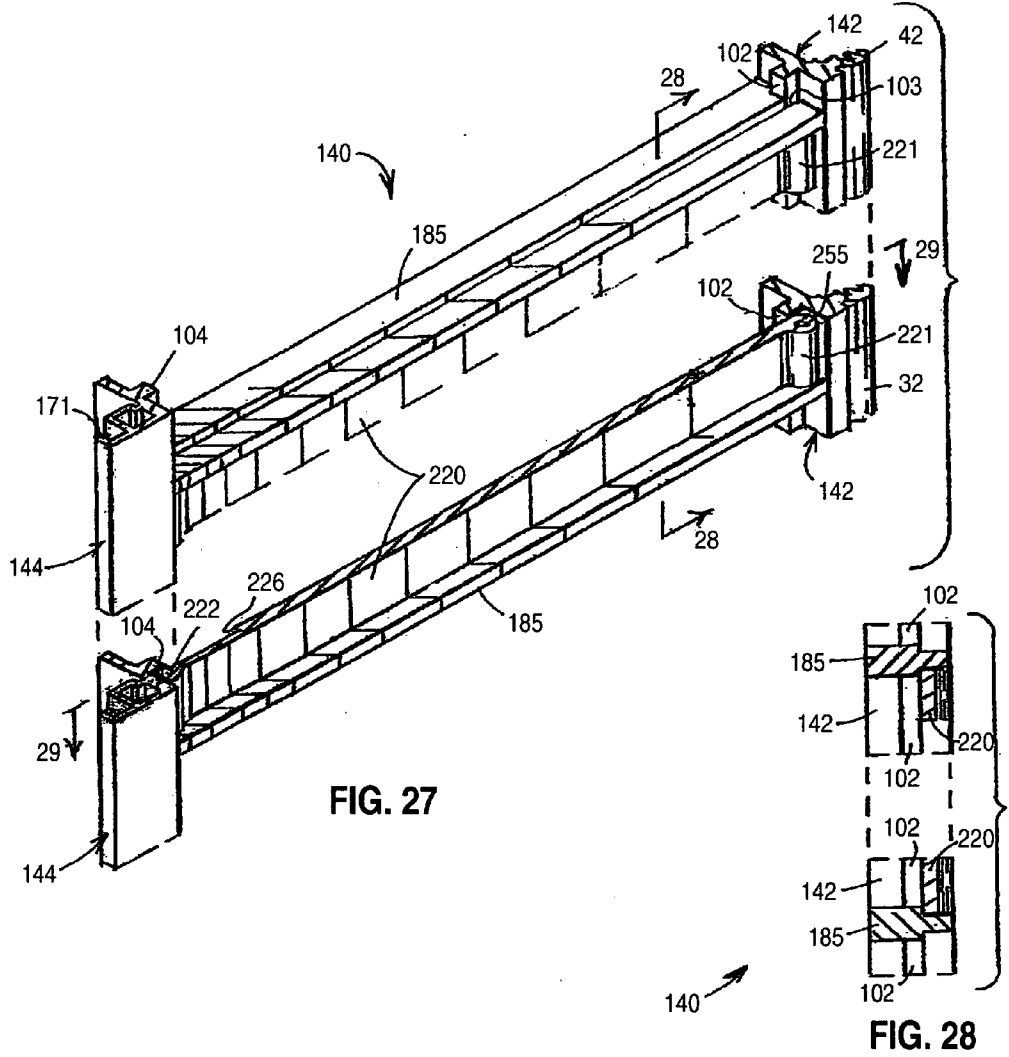

FIG. 27

FIG. 28

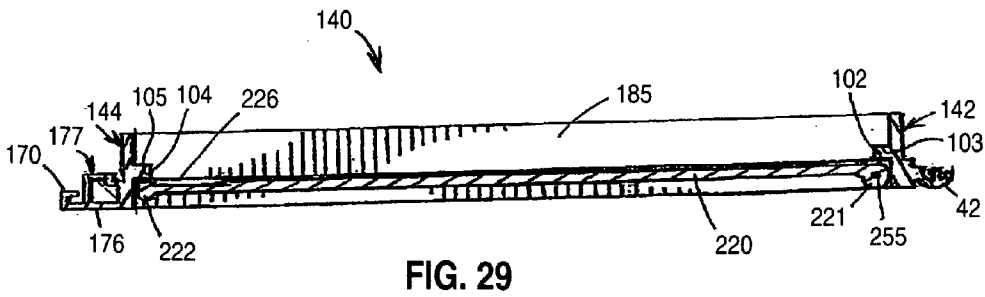

FIG. 29

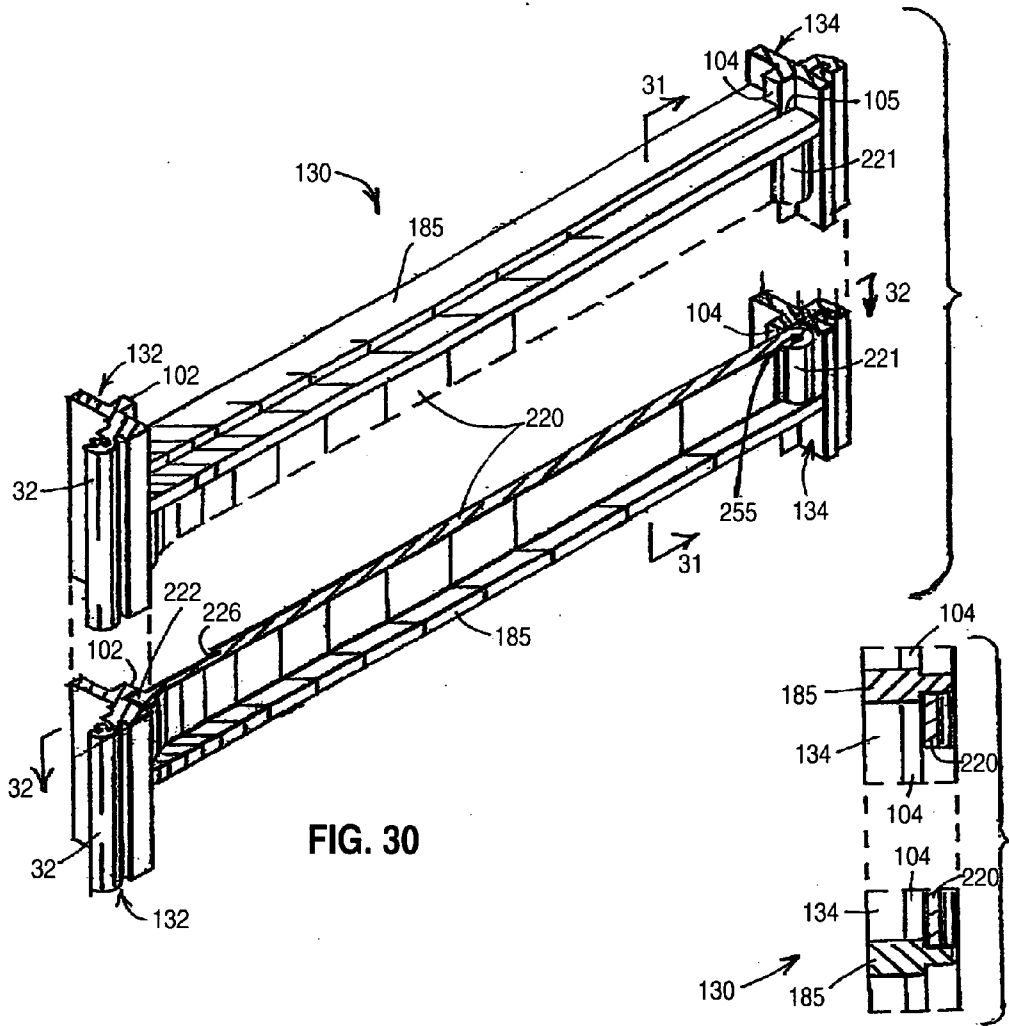

FIG. 30

FIG. 31

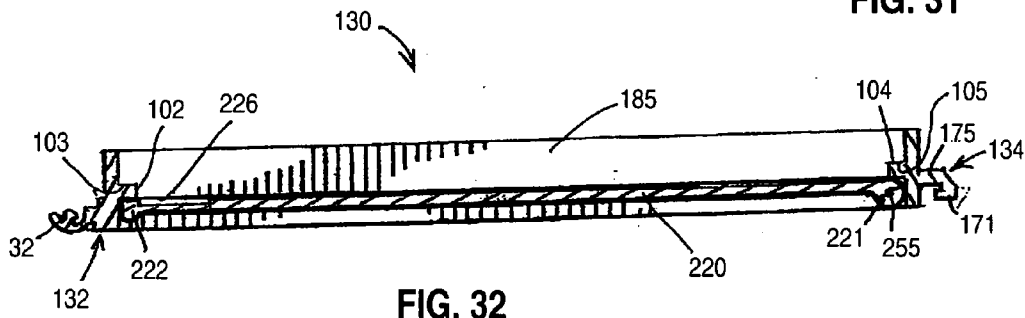

FIG. 32

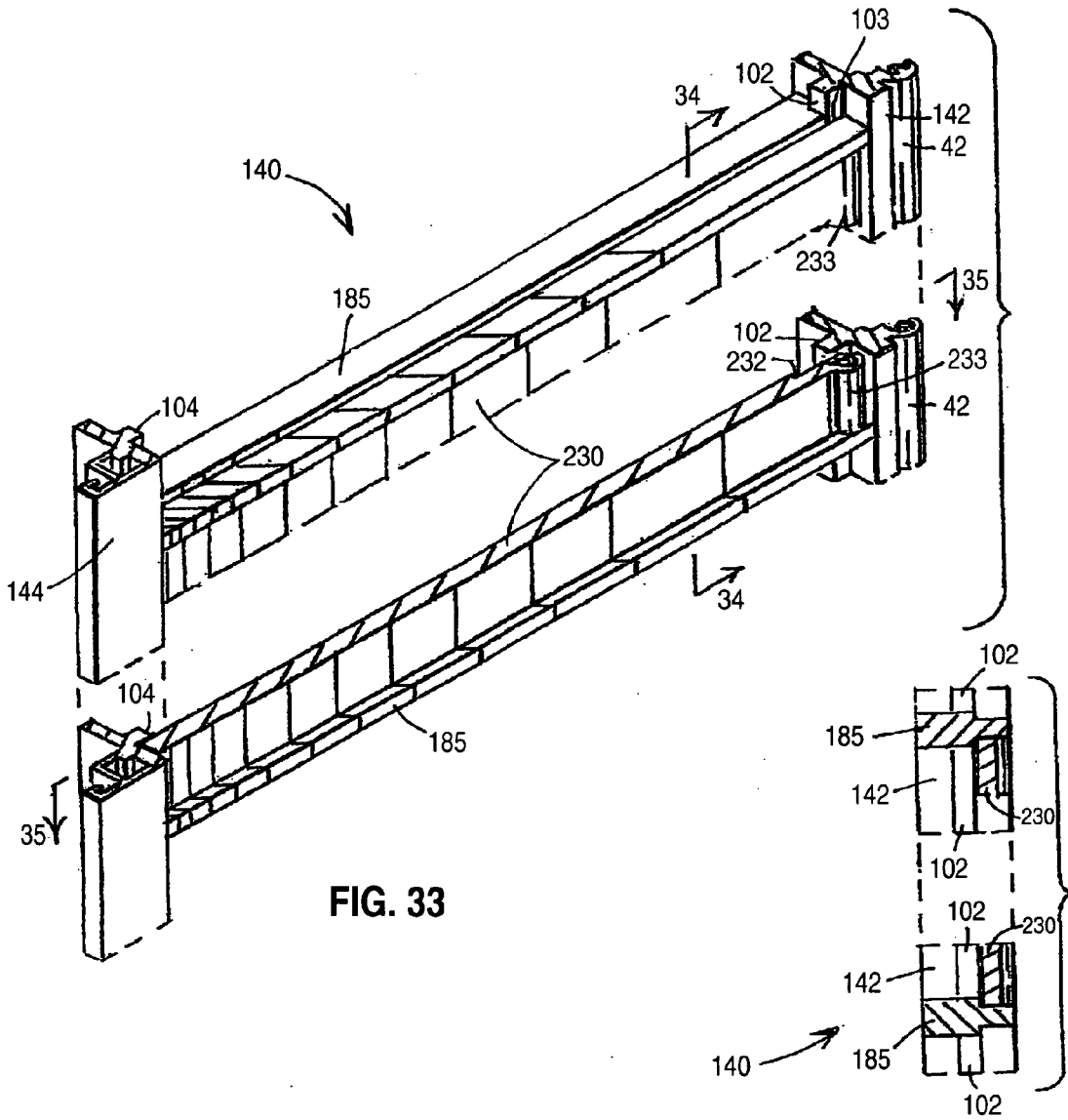

FIG. 33

FIG. 34

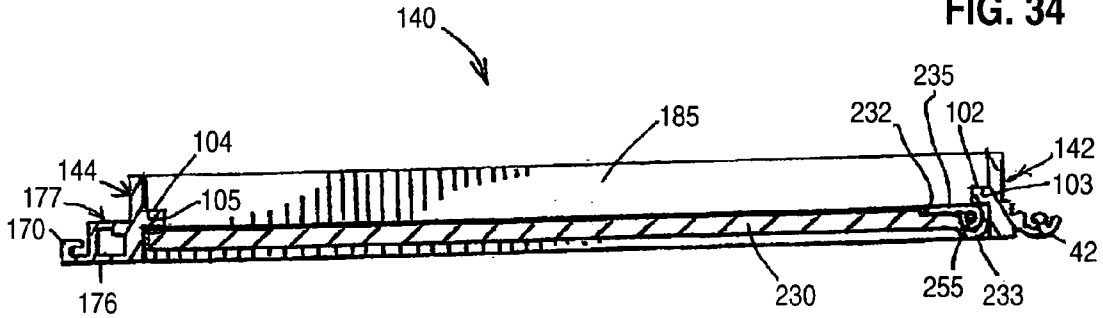

FIG. 35

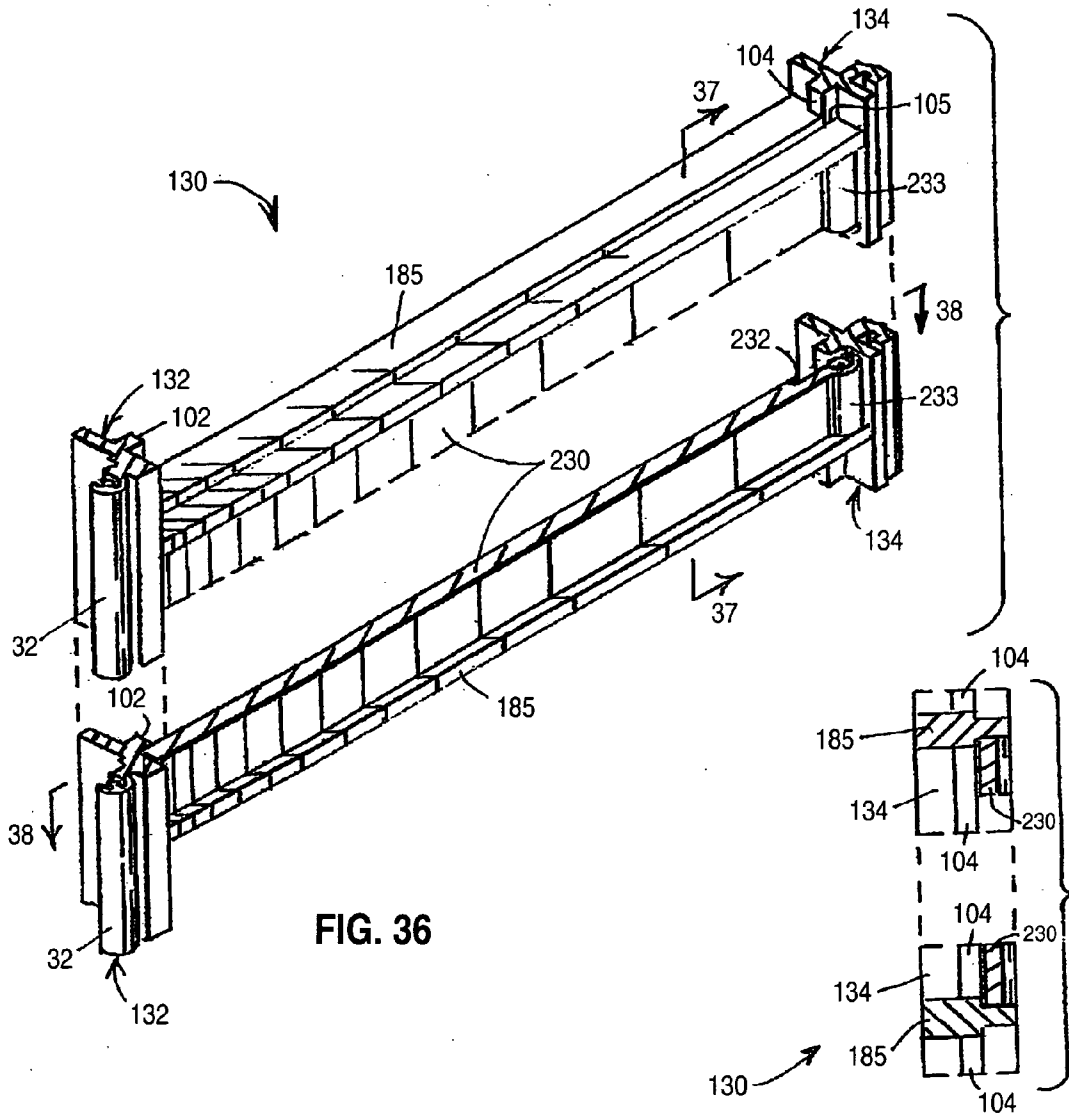

FIG. 36

FIG. 37

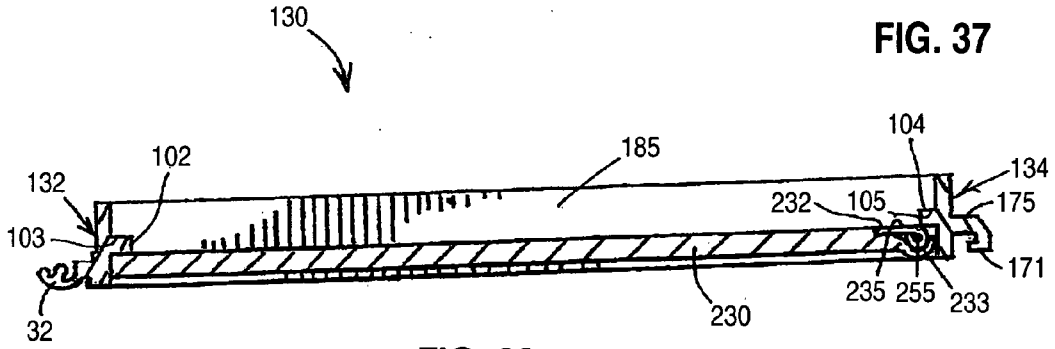

FIG. 38

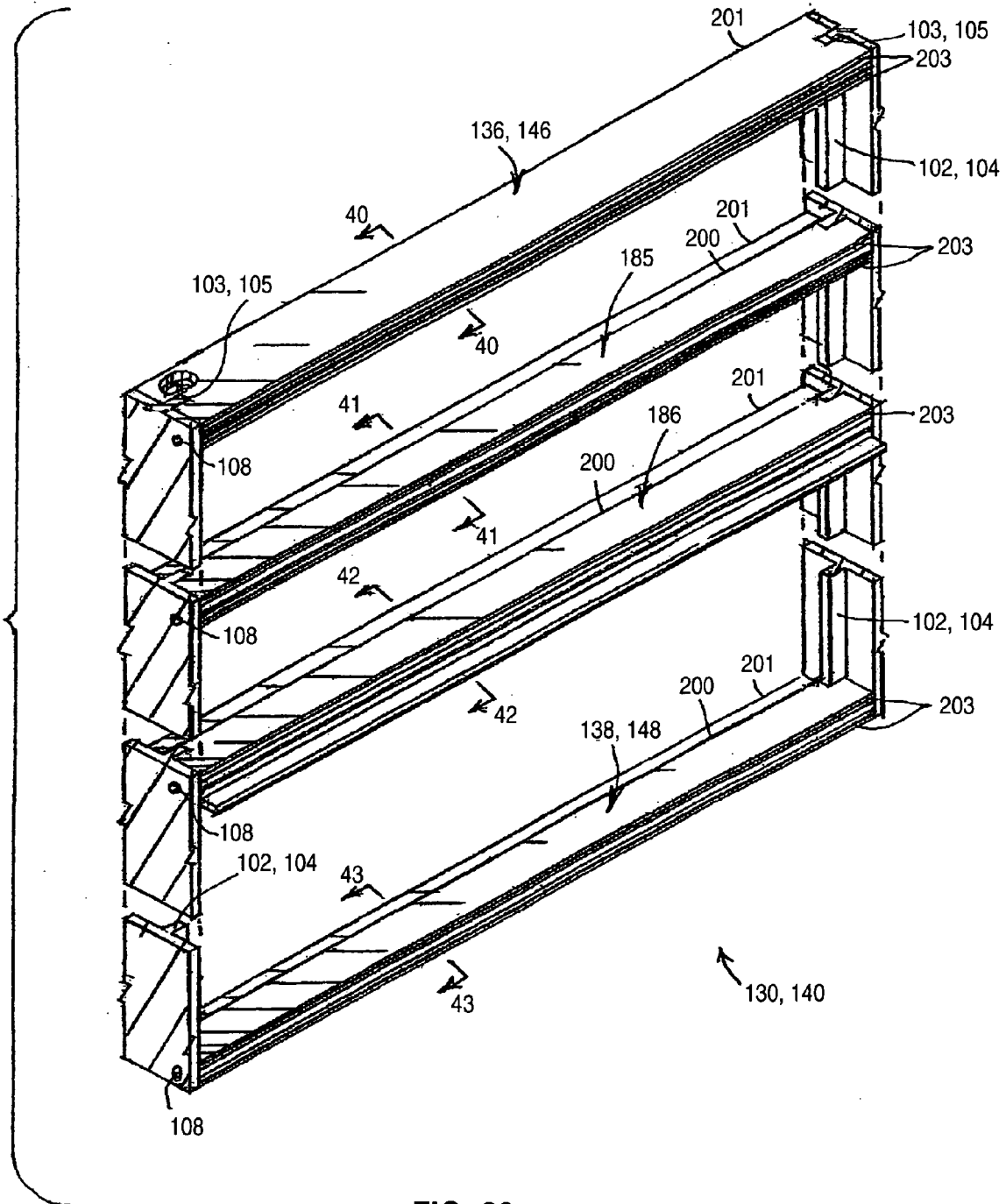

FIG. 39

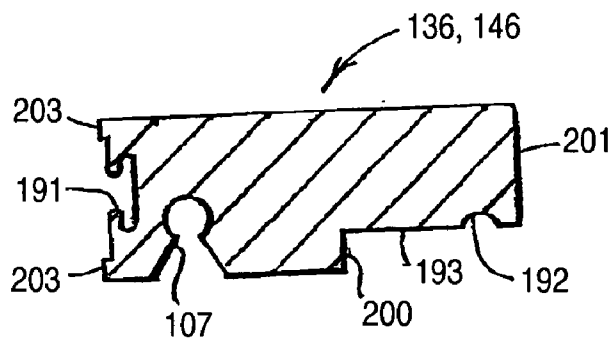

FIG. 40

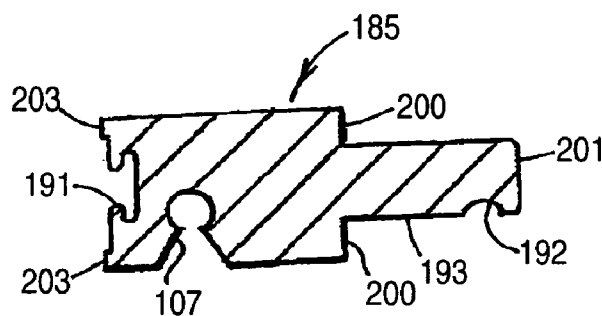

FIG. 41

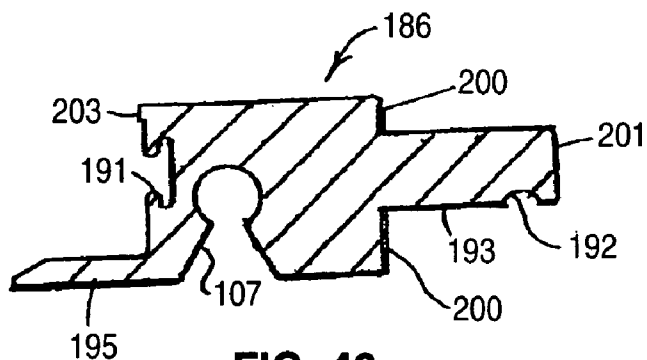

FIG. 42

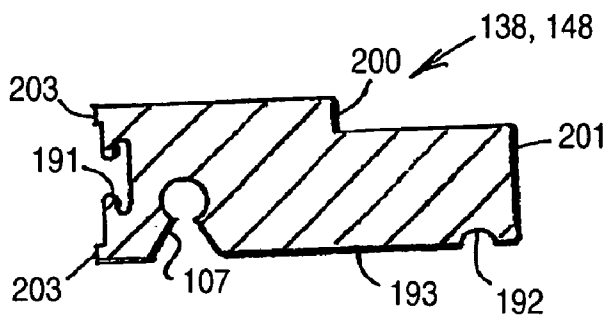

FIG. 43

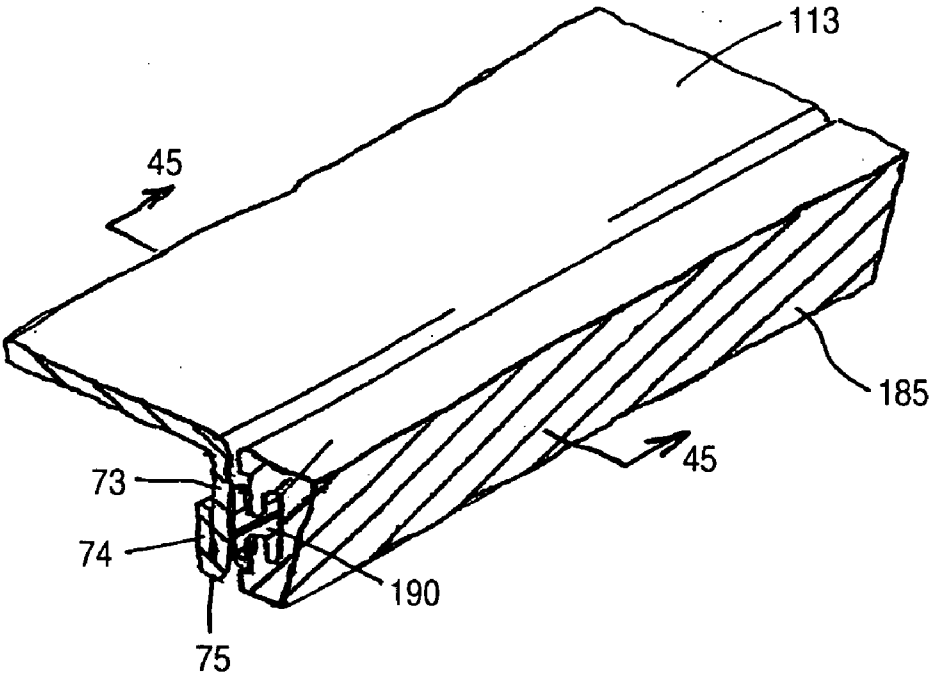

FIG. 44

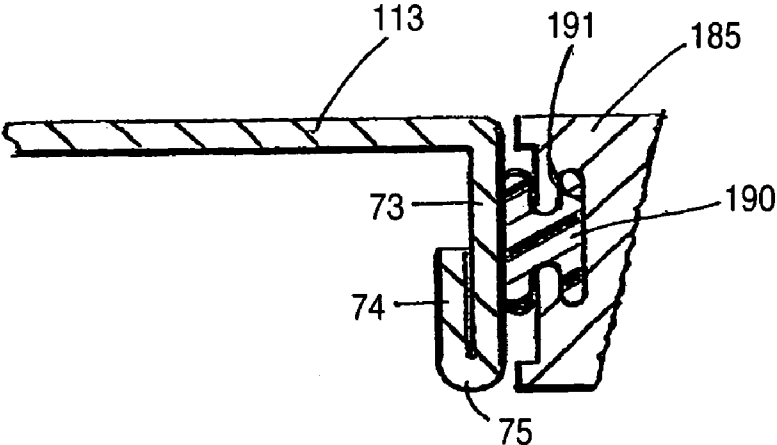

FIG. 45

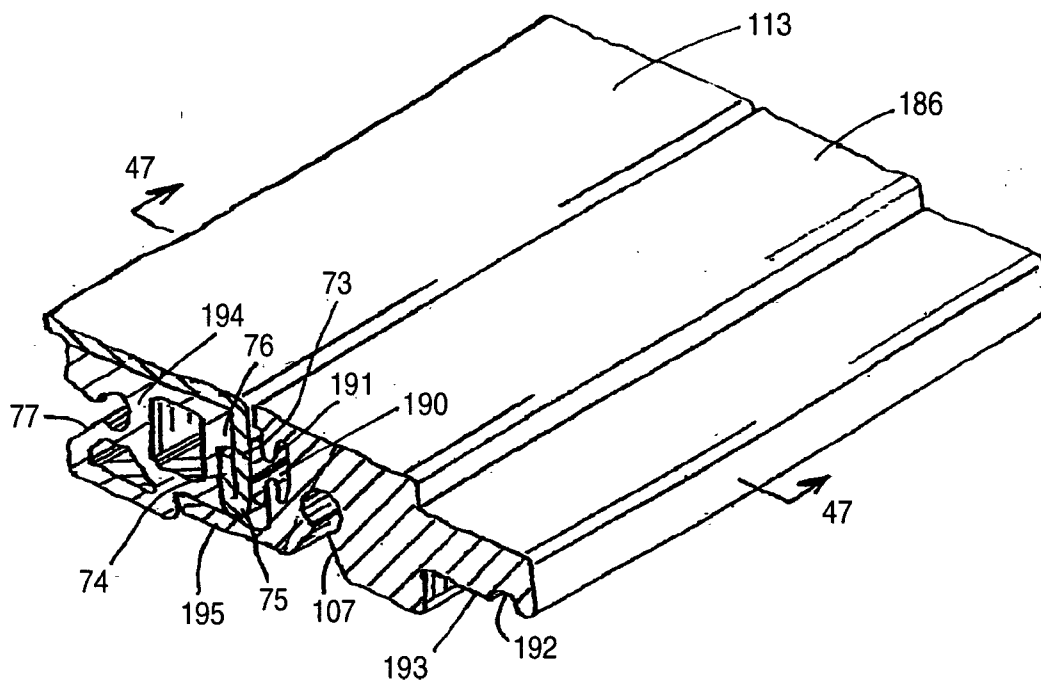

FIG. 46

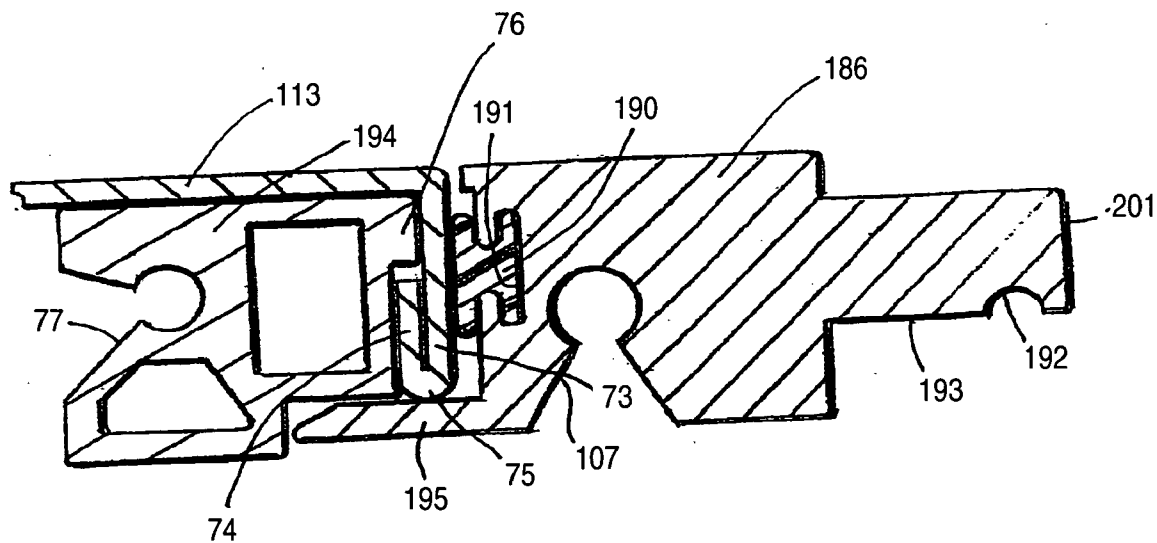

FIG. 47

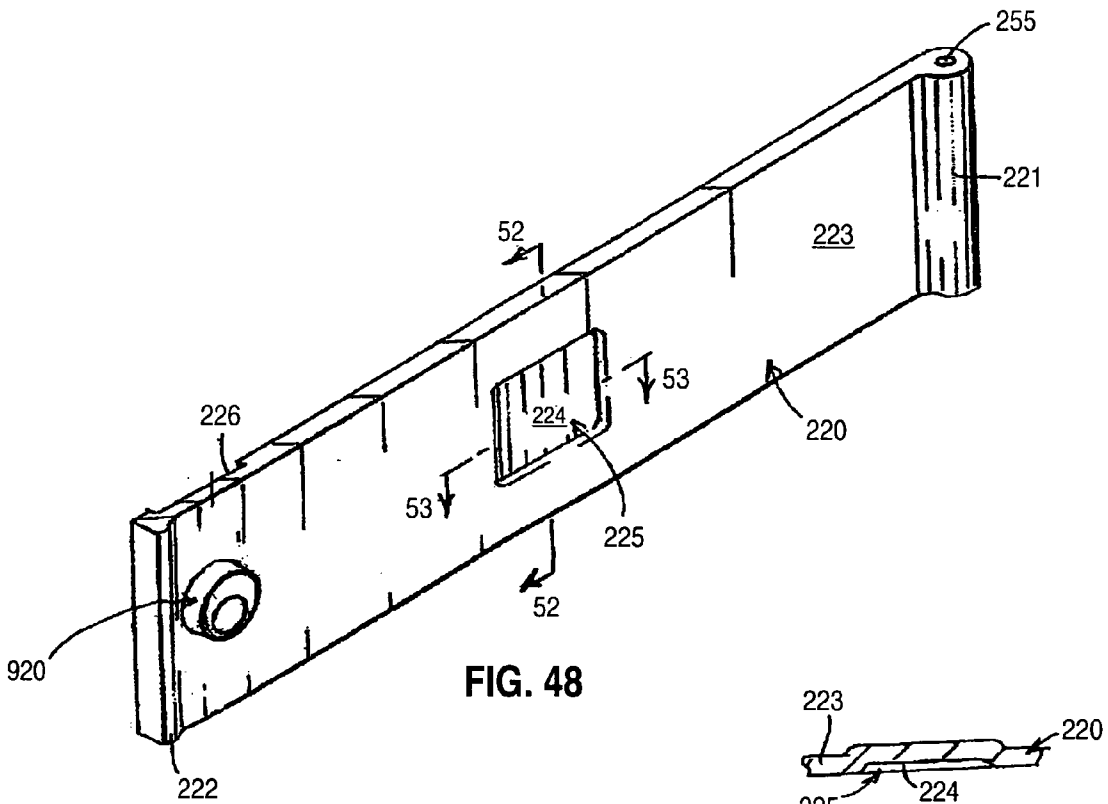

FIG. 48

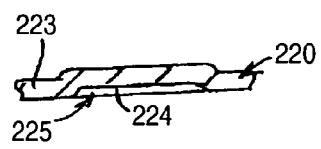

FIG. 53

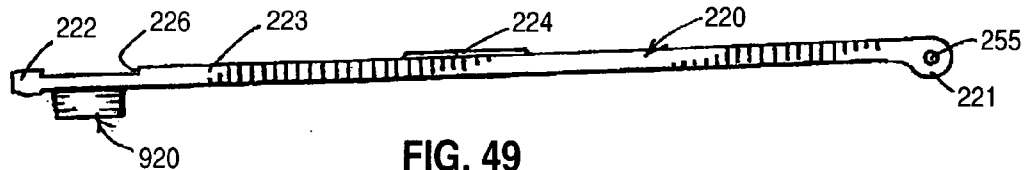

FIG. 49

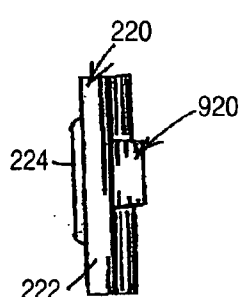

FIG. 50

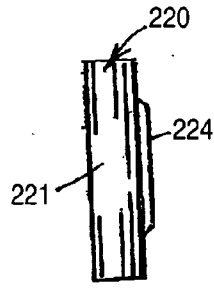

FIG. 51

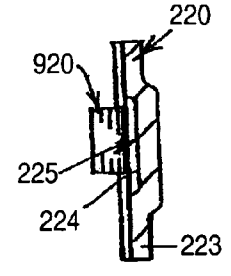
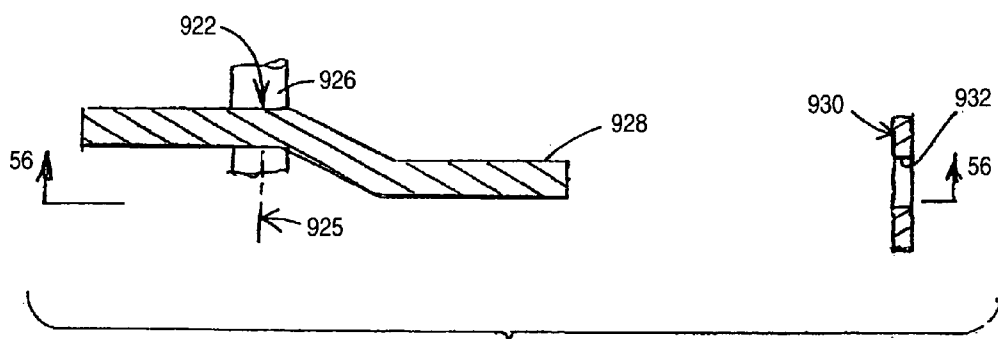
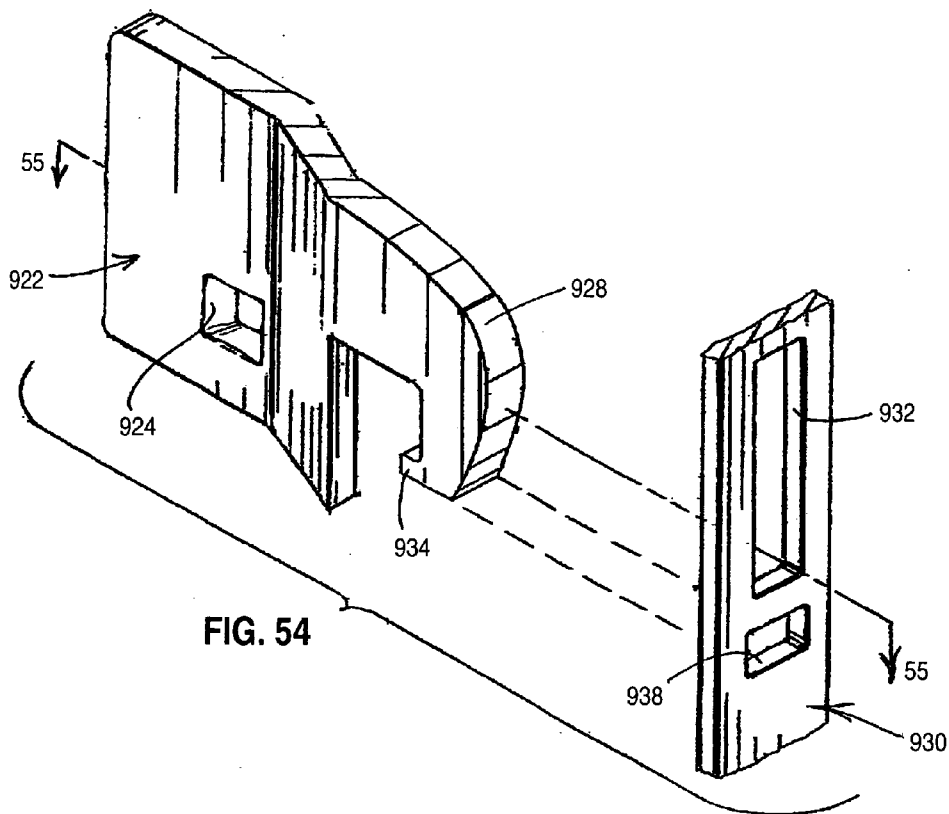

FIG. 52



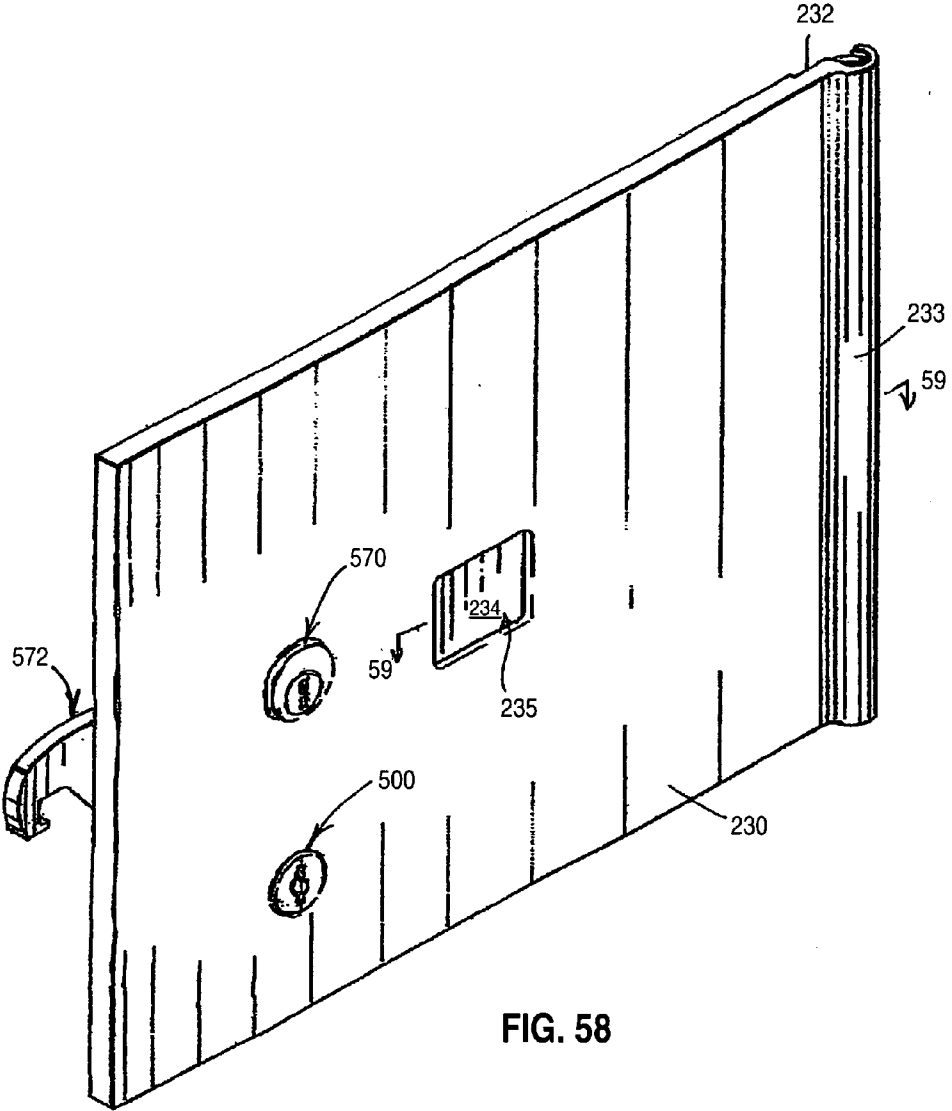

FIG. 58

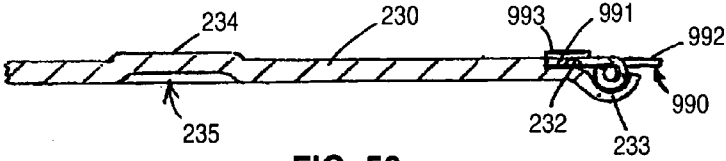

FIG. 59

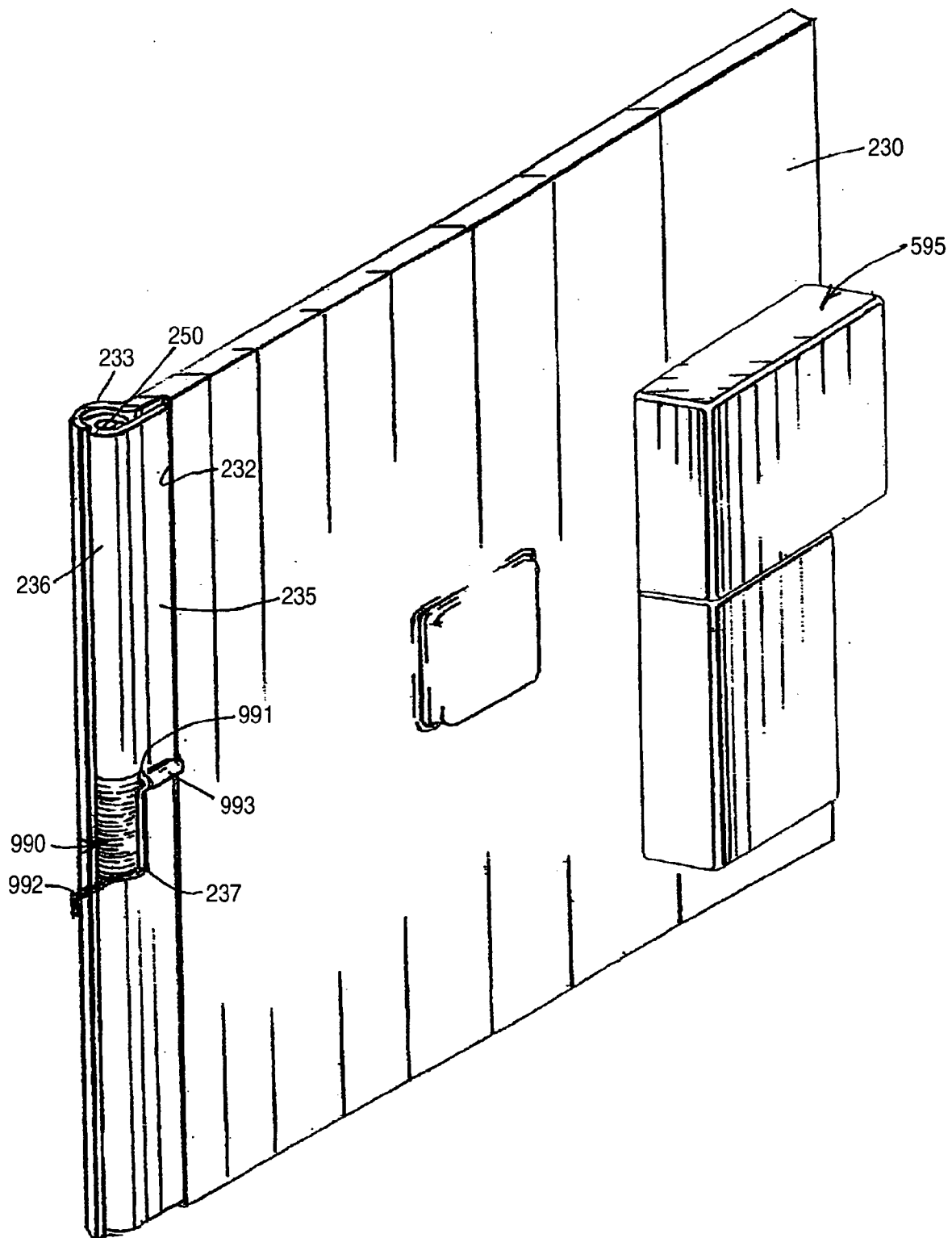

FIG. 60

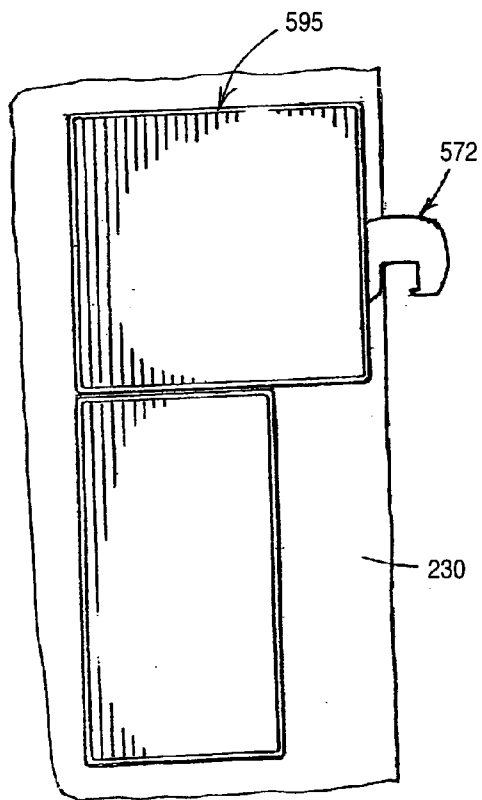

FIG. 61

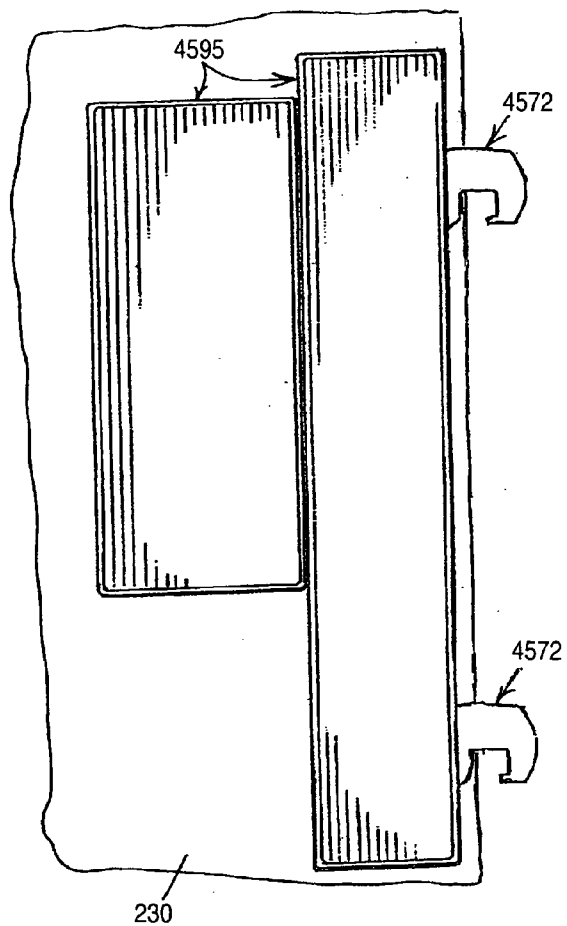

FIG. 62

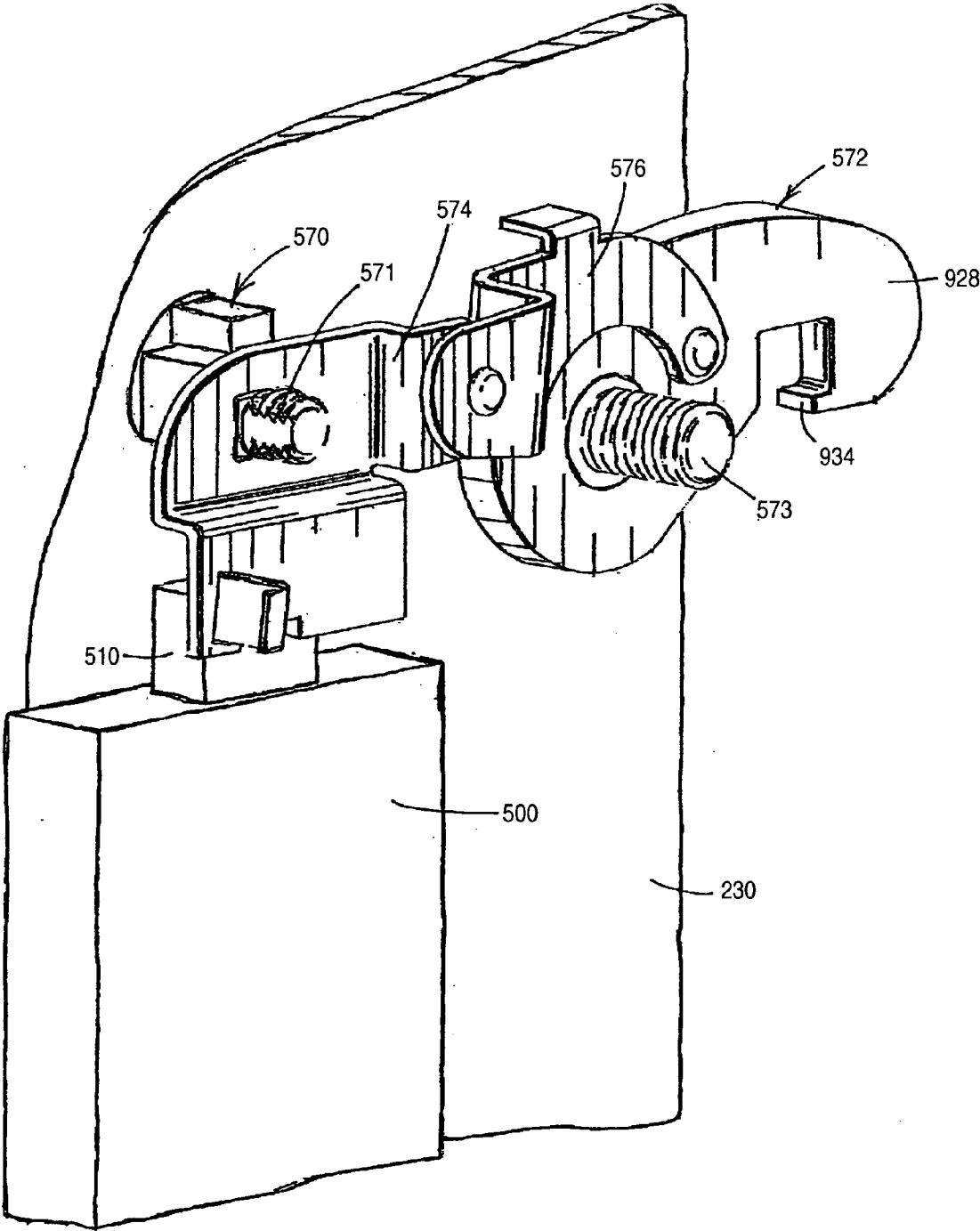

FIG. 63

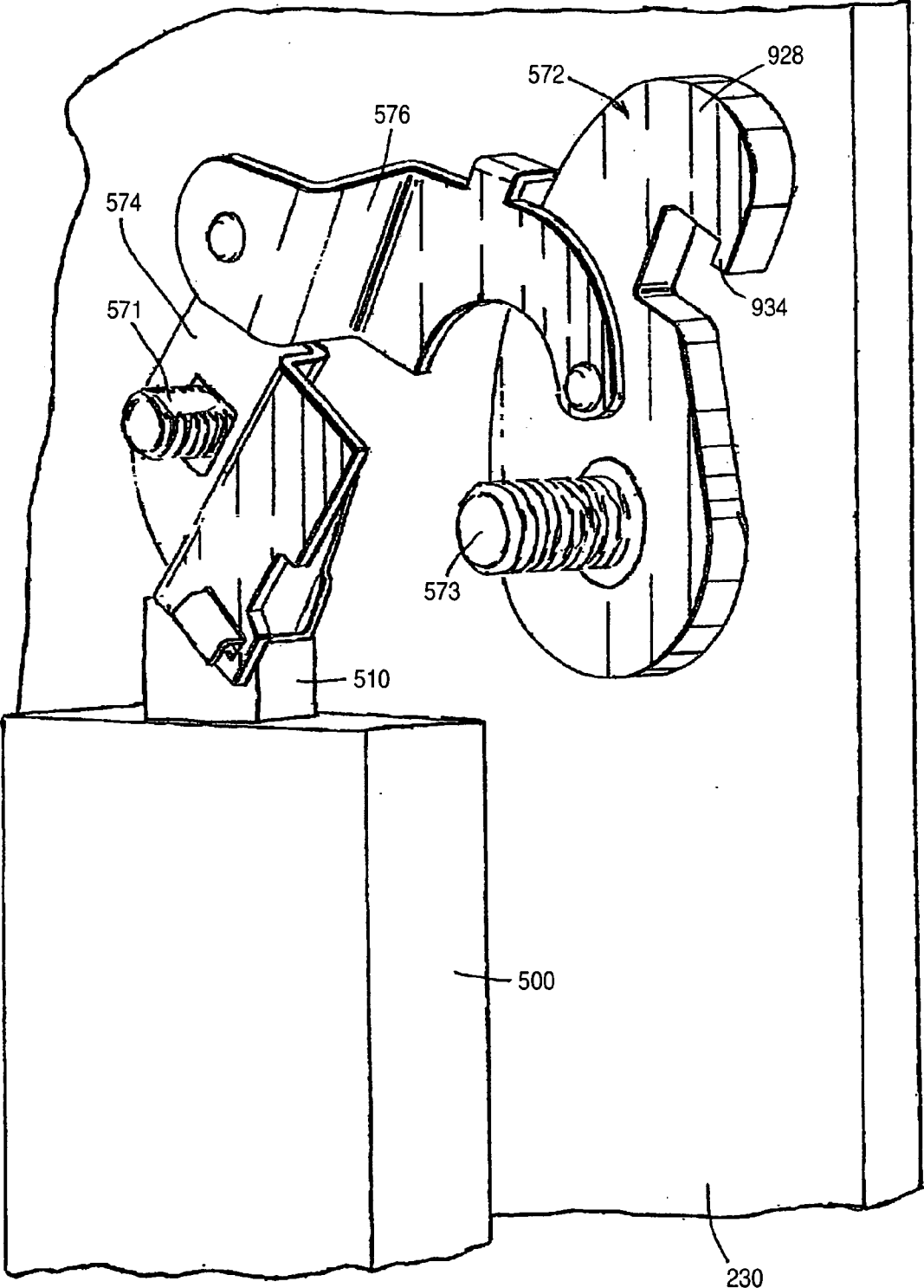

FIG. 64

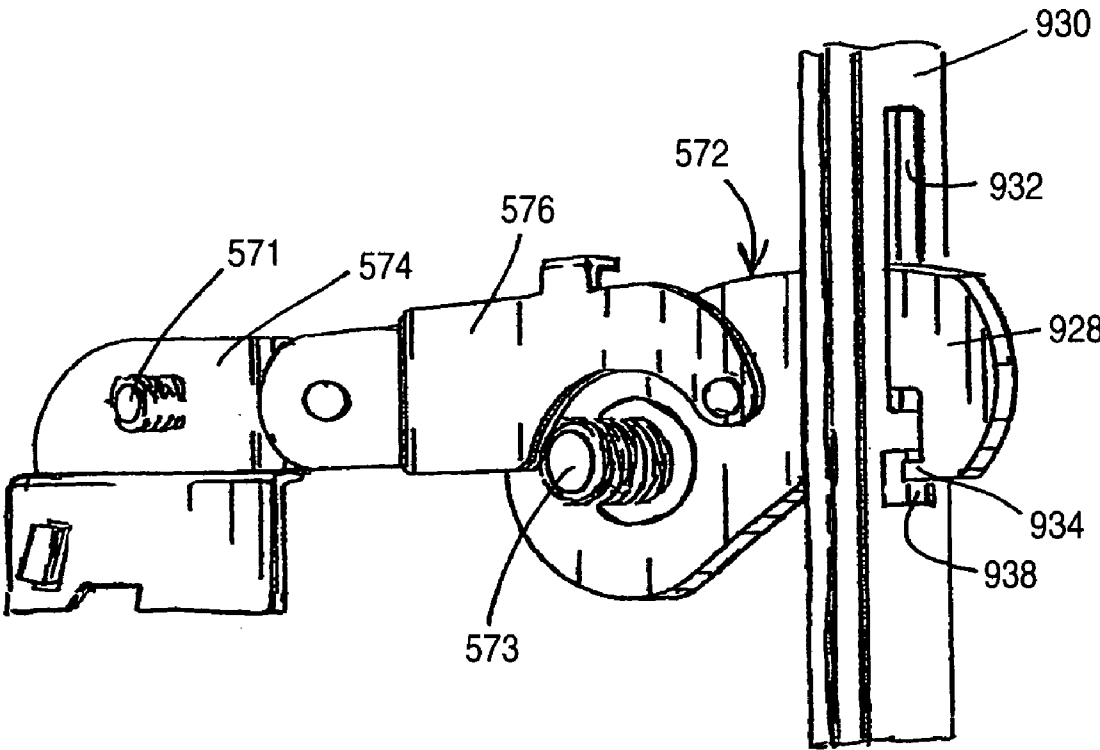

FIG. 65

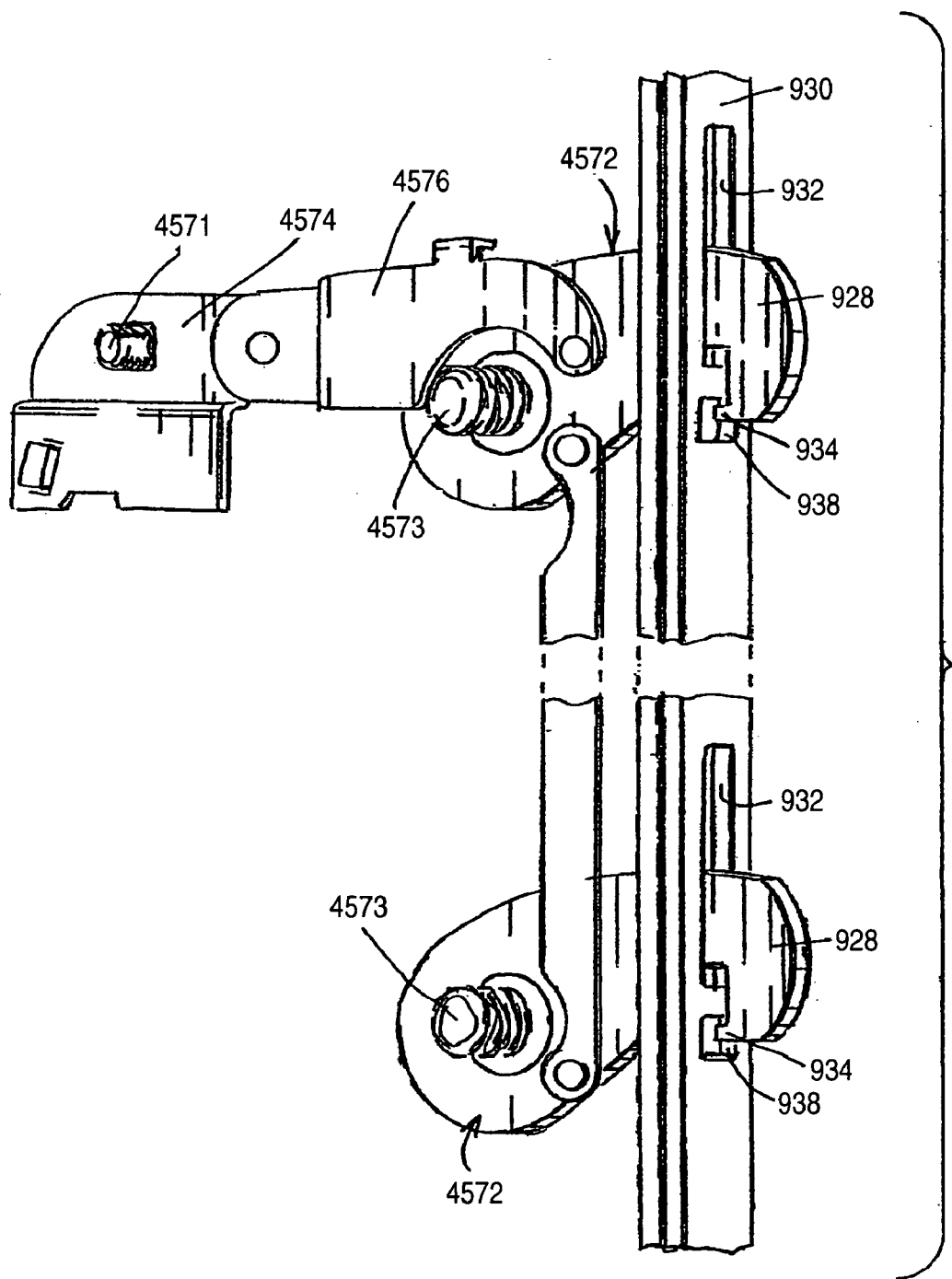

FIG. 66

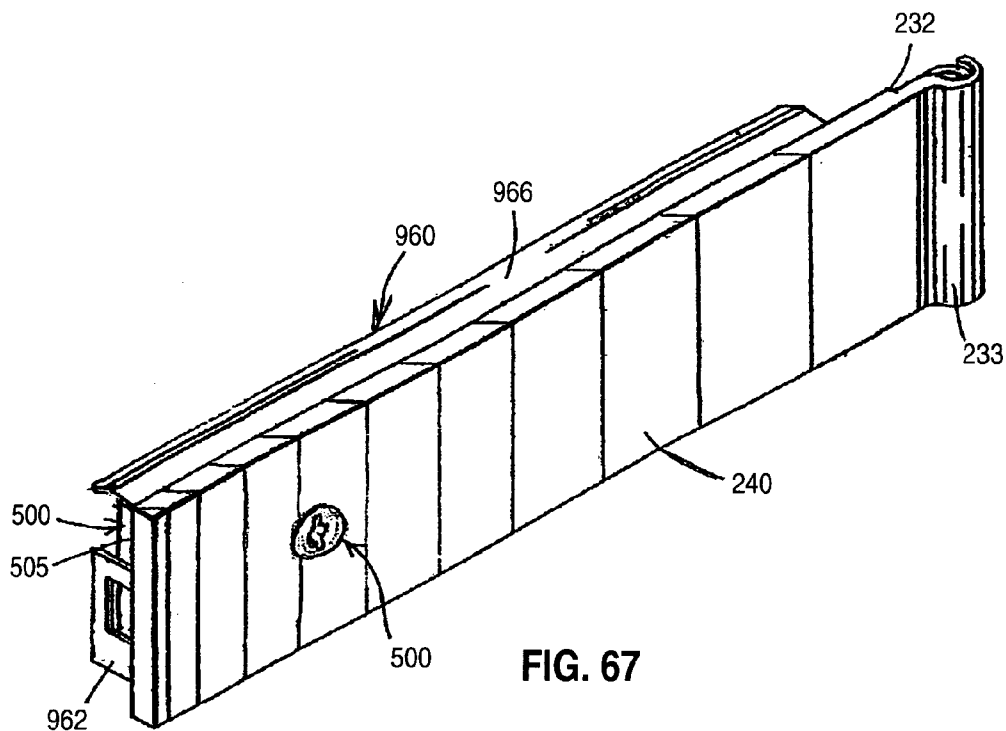

FIG. 67

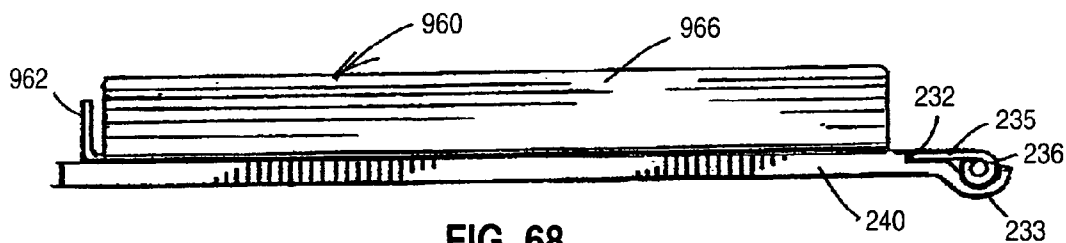

FIG. 68

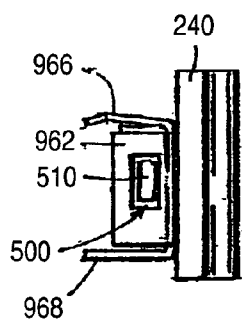

FIG. 69

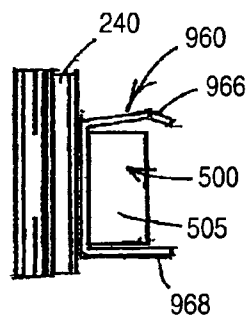

FIG. 70

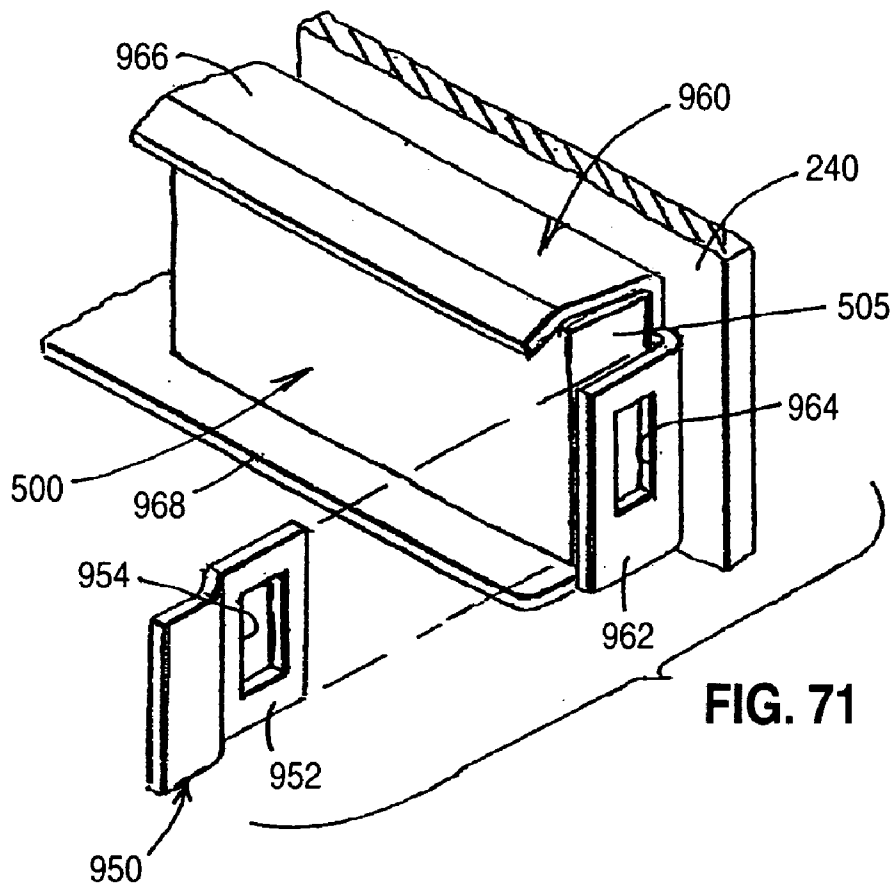

FIG. 71

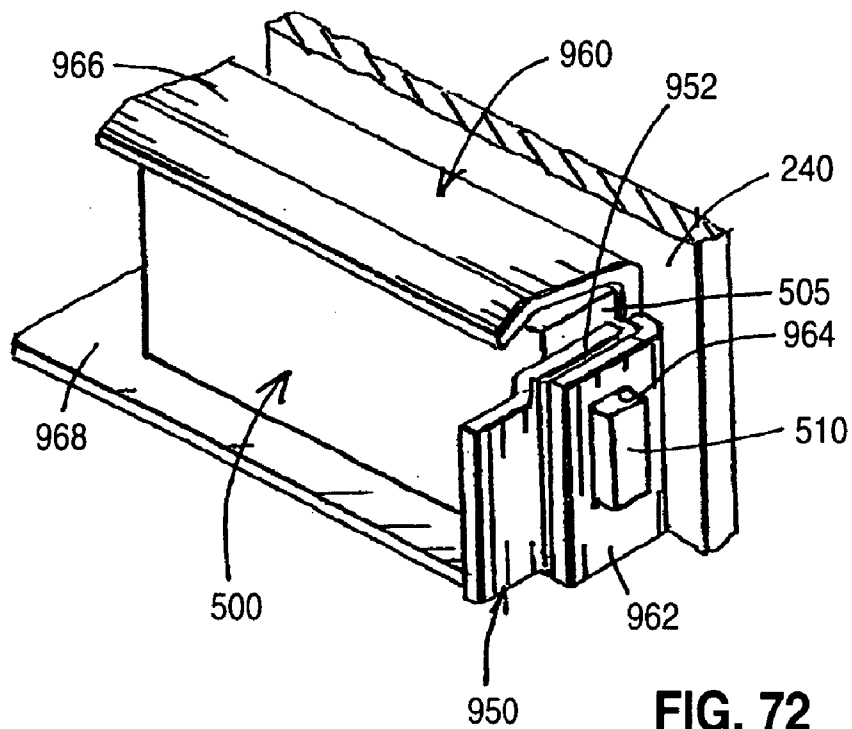

FIG. 72

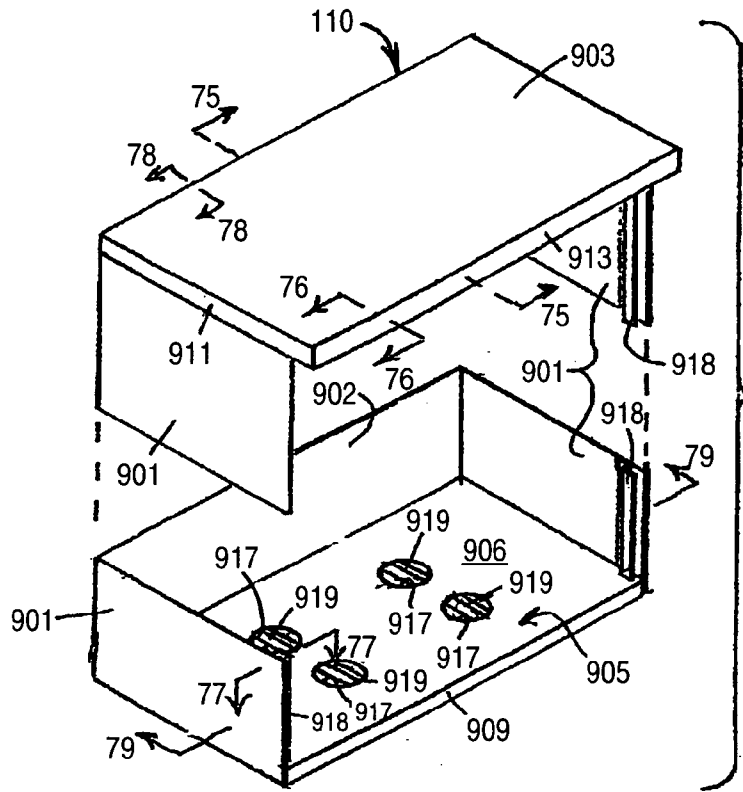

FIG. 73

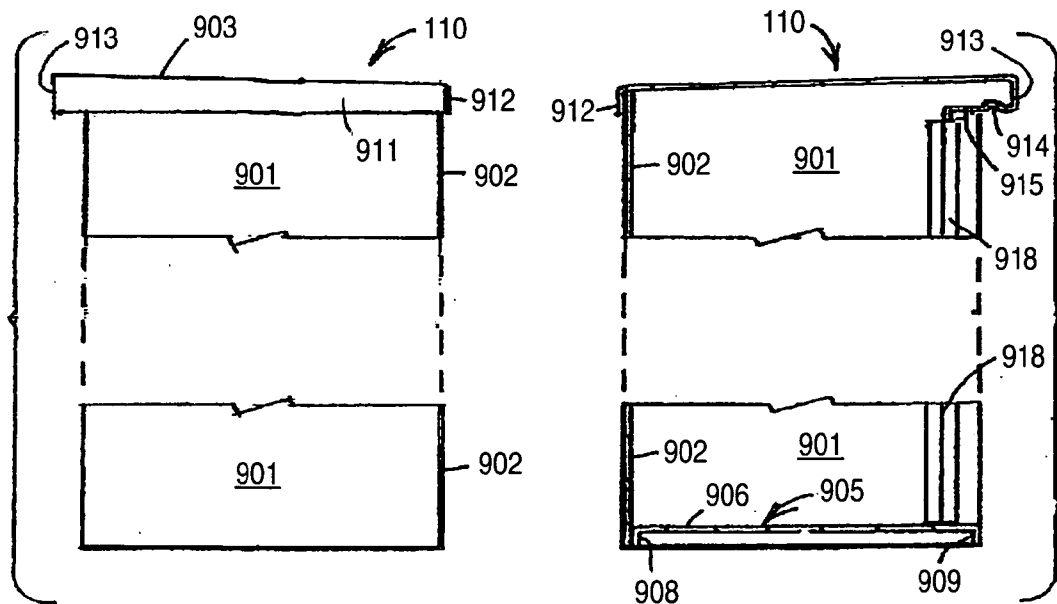

FIG. 74

FIG. 75

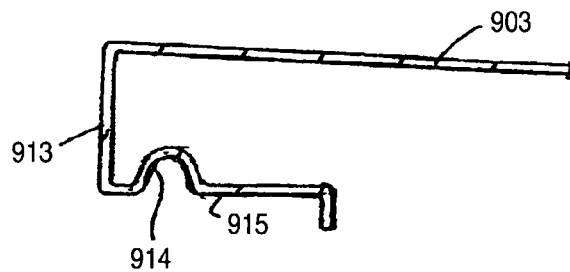

FIG. 76

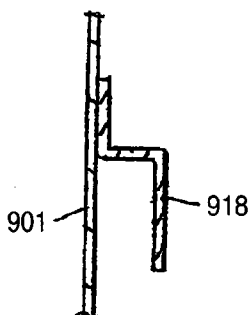

FIG. 77

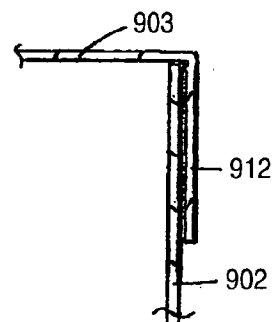

FIG. 78

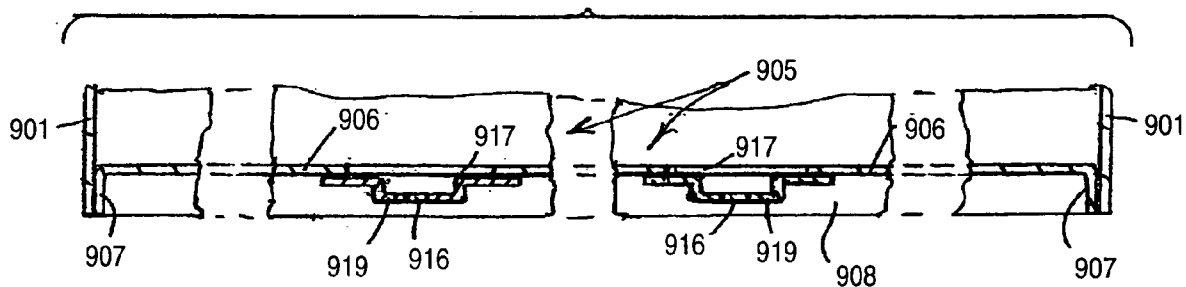

FIG. 79

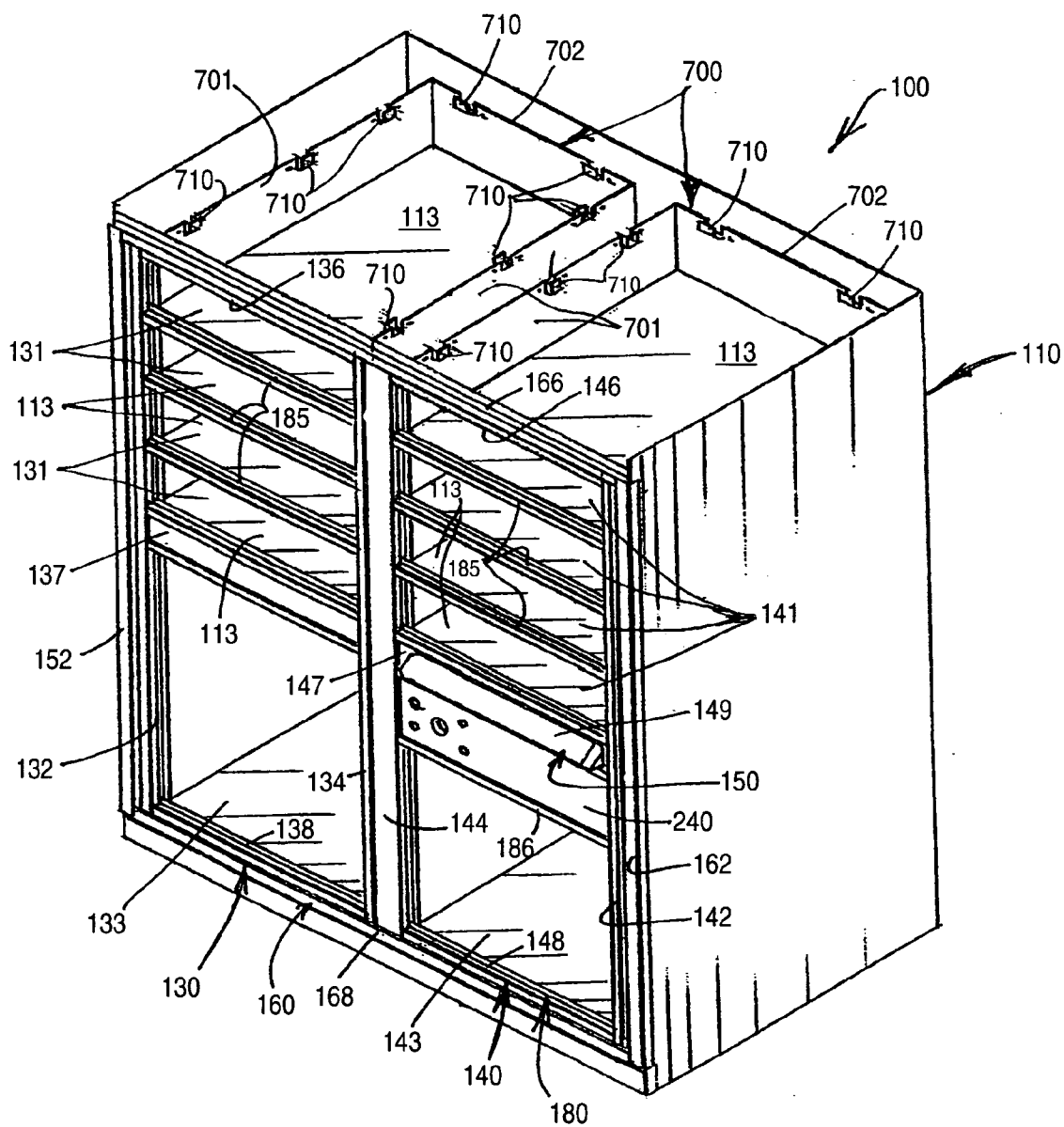

FIG. 80

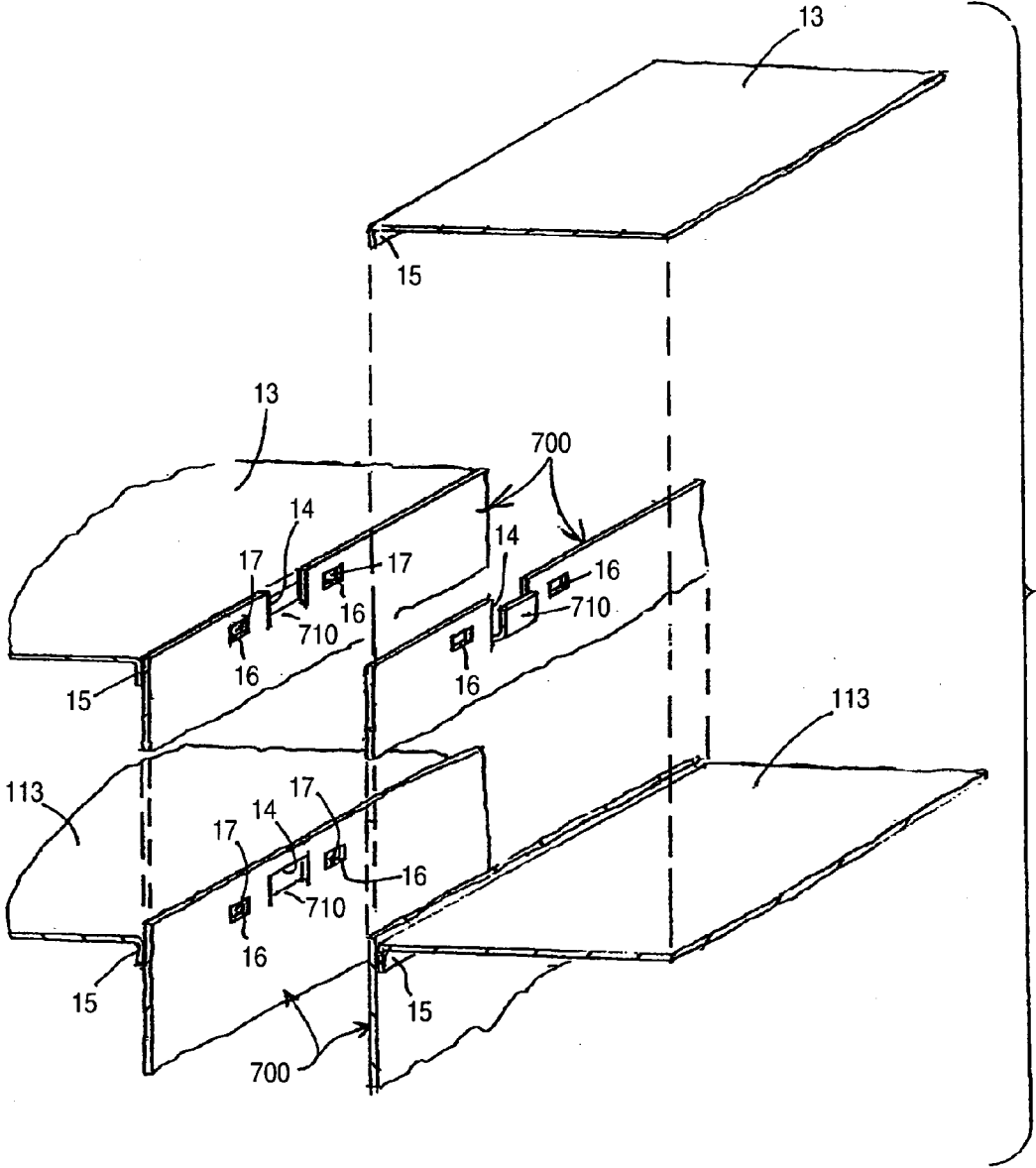

FIG. 81

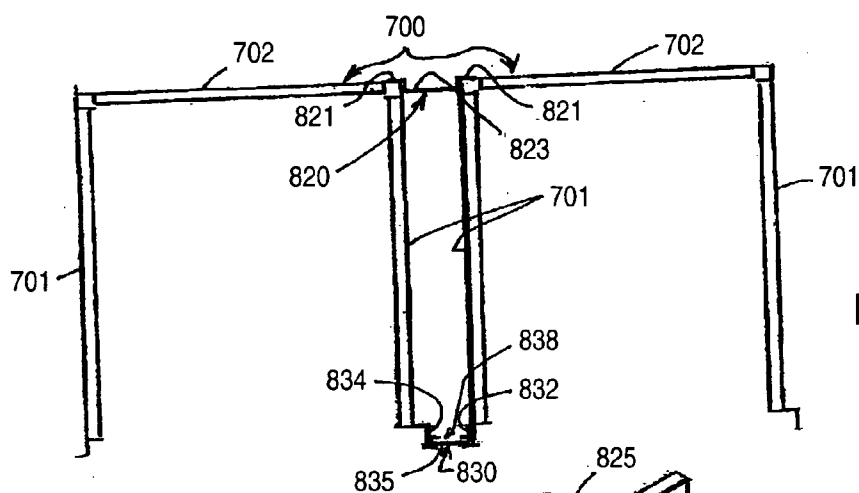

FIG. 82

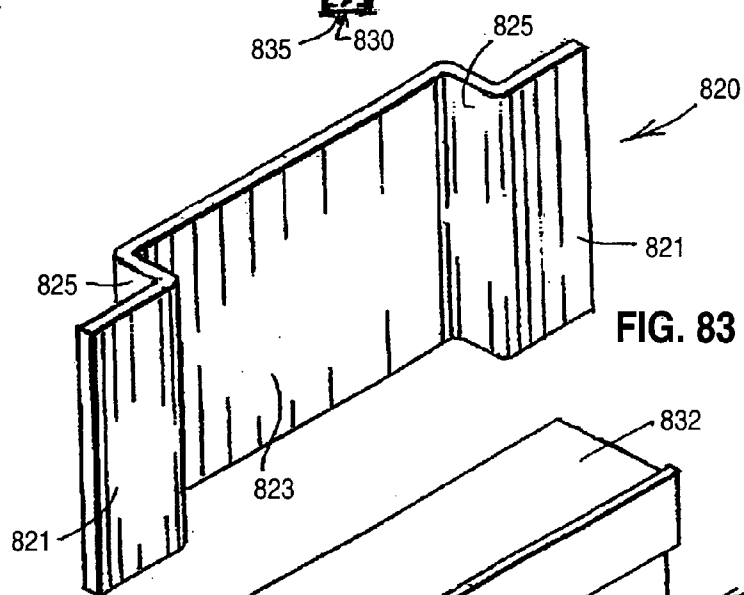

FIG. 83

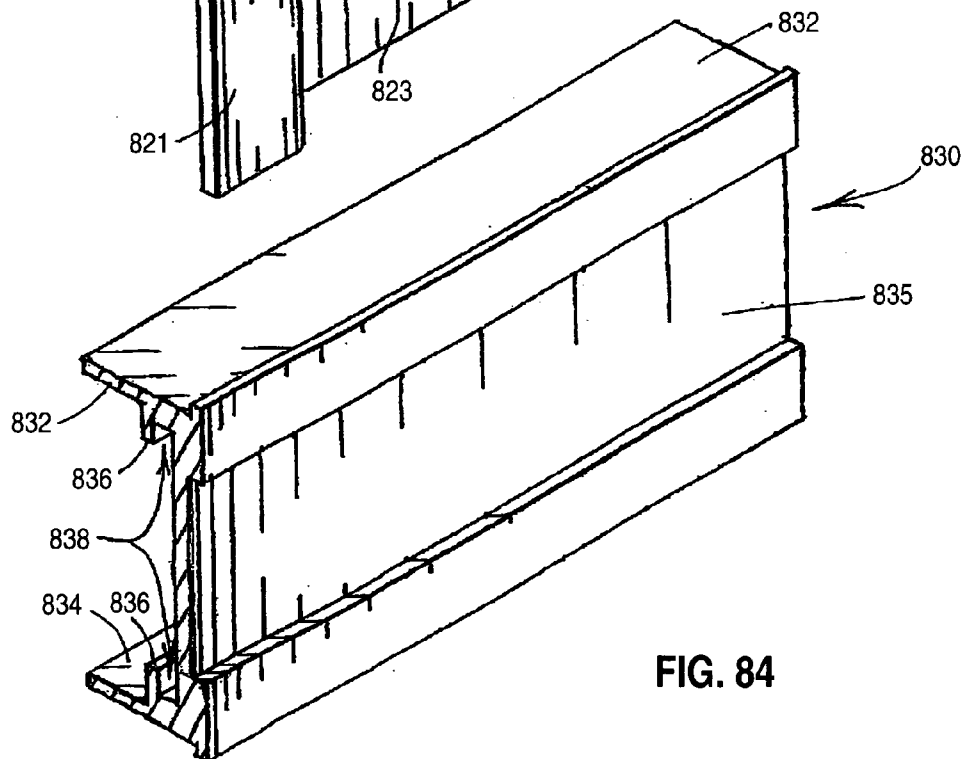
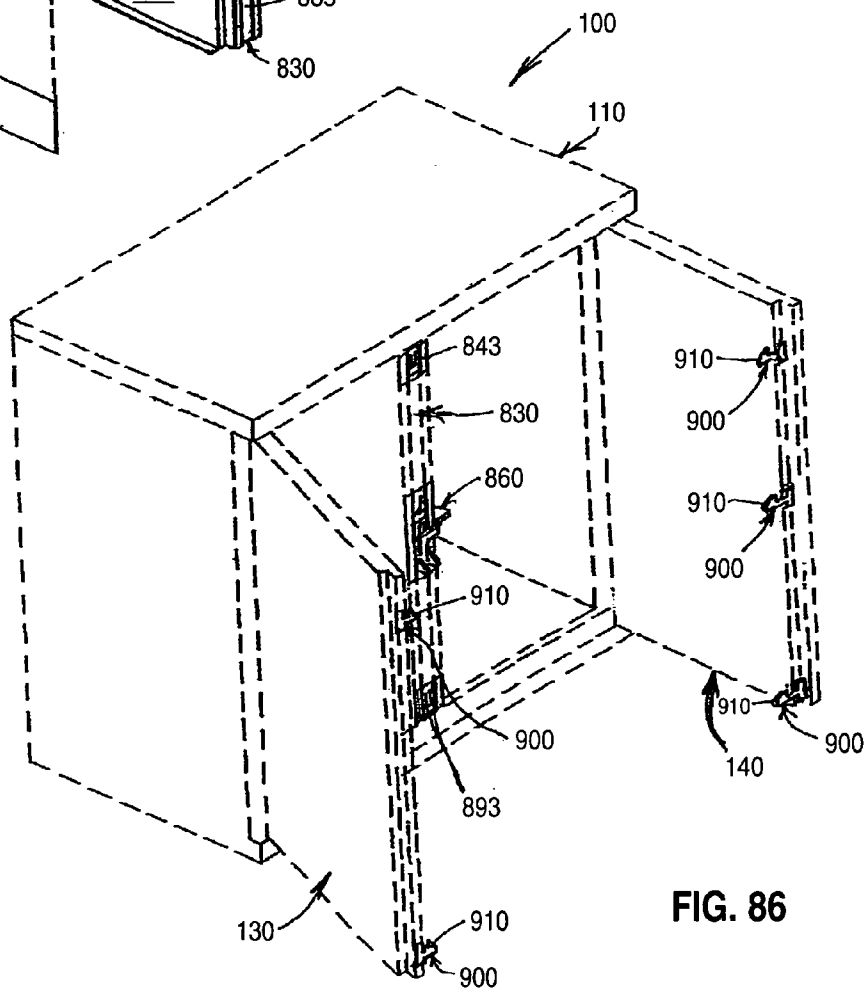
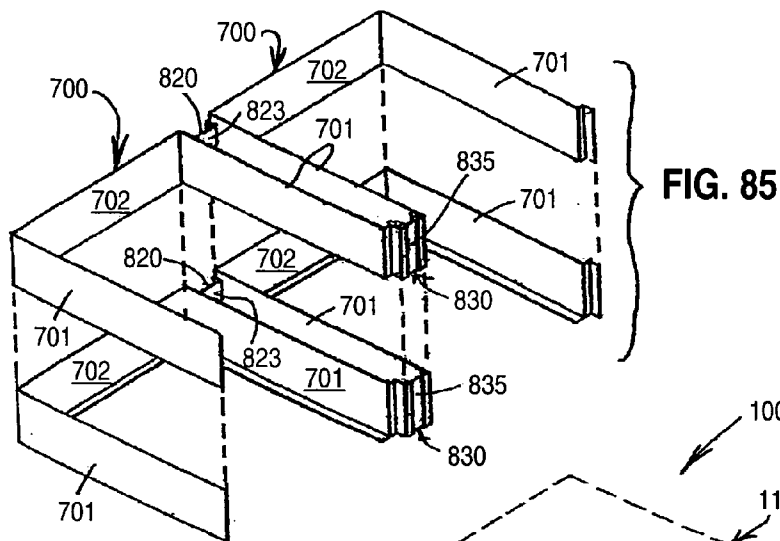
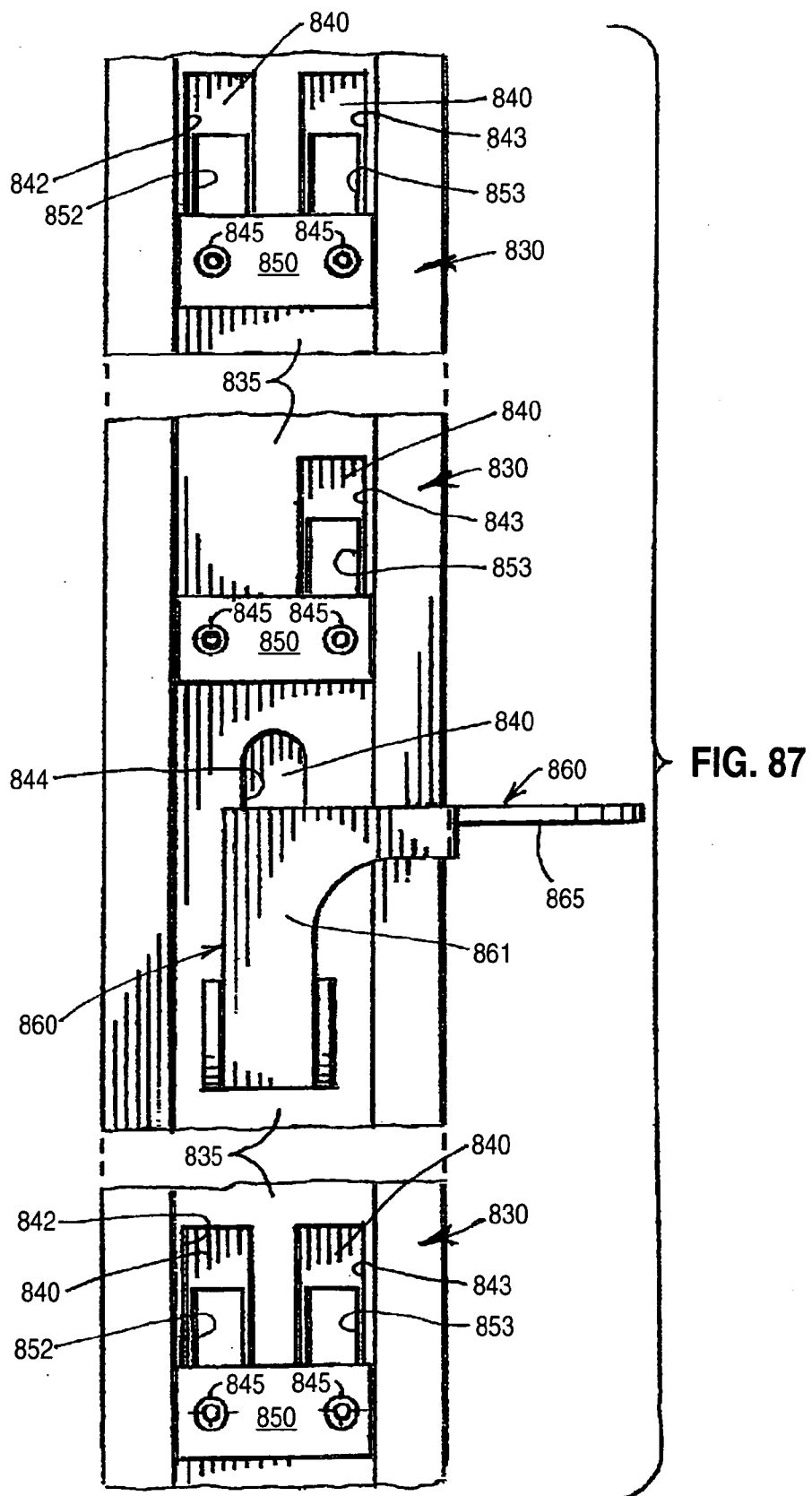

FIG. 84





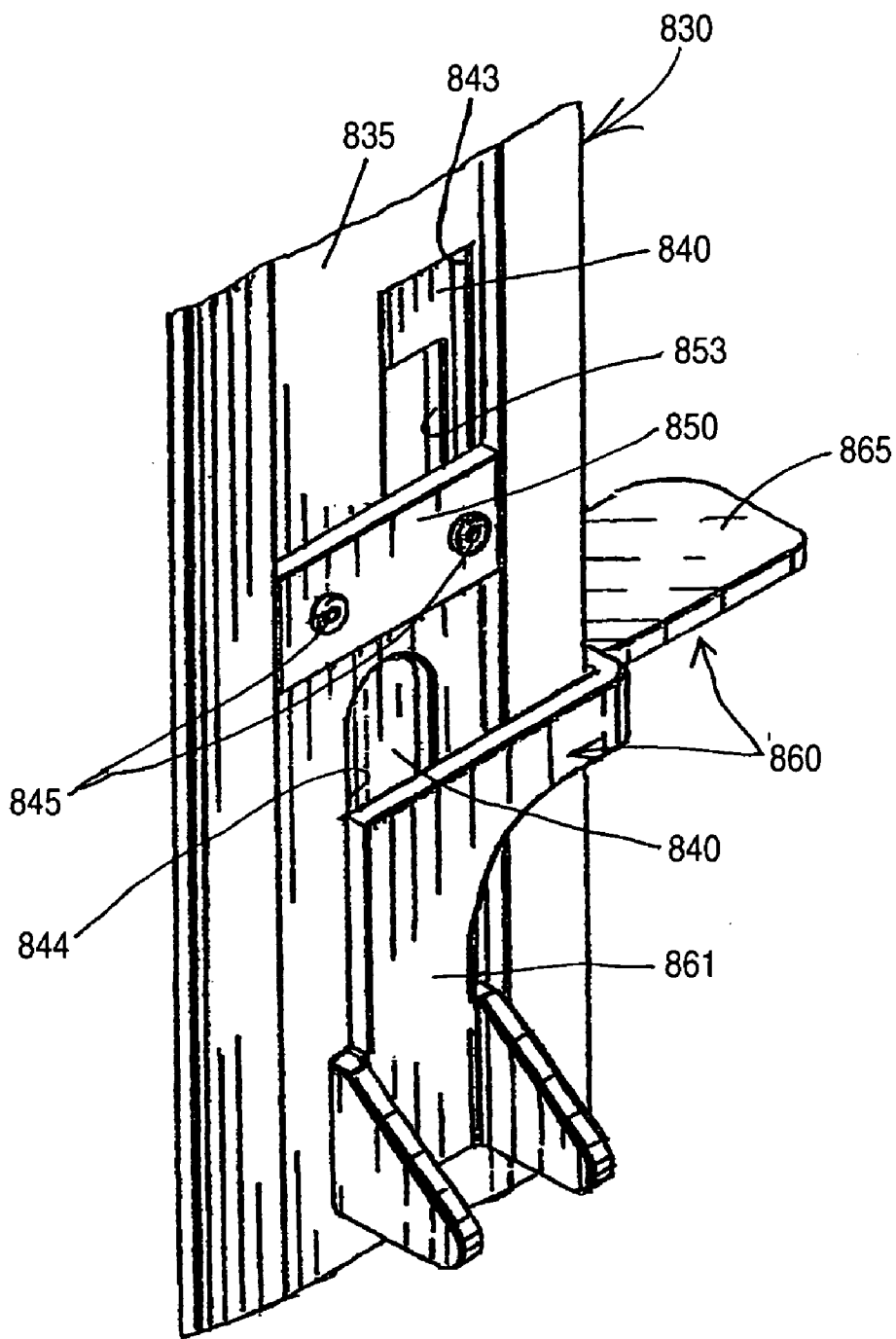

FIG. 88

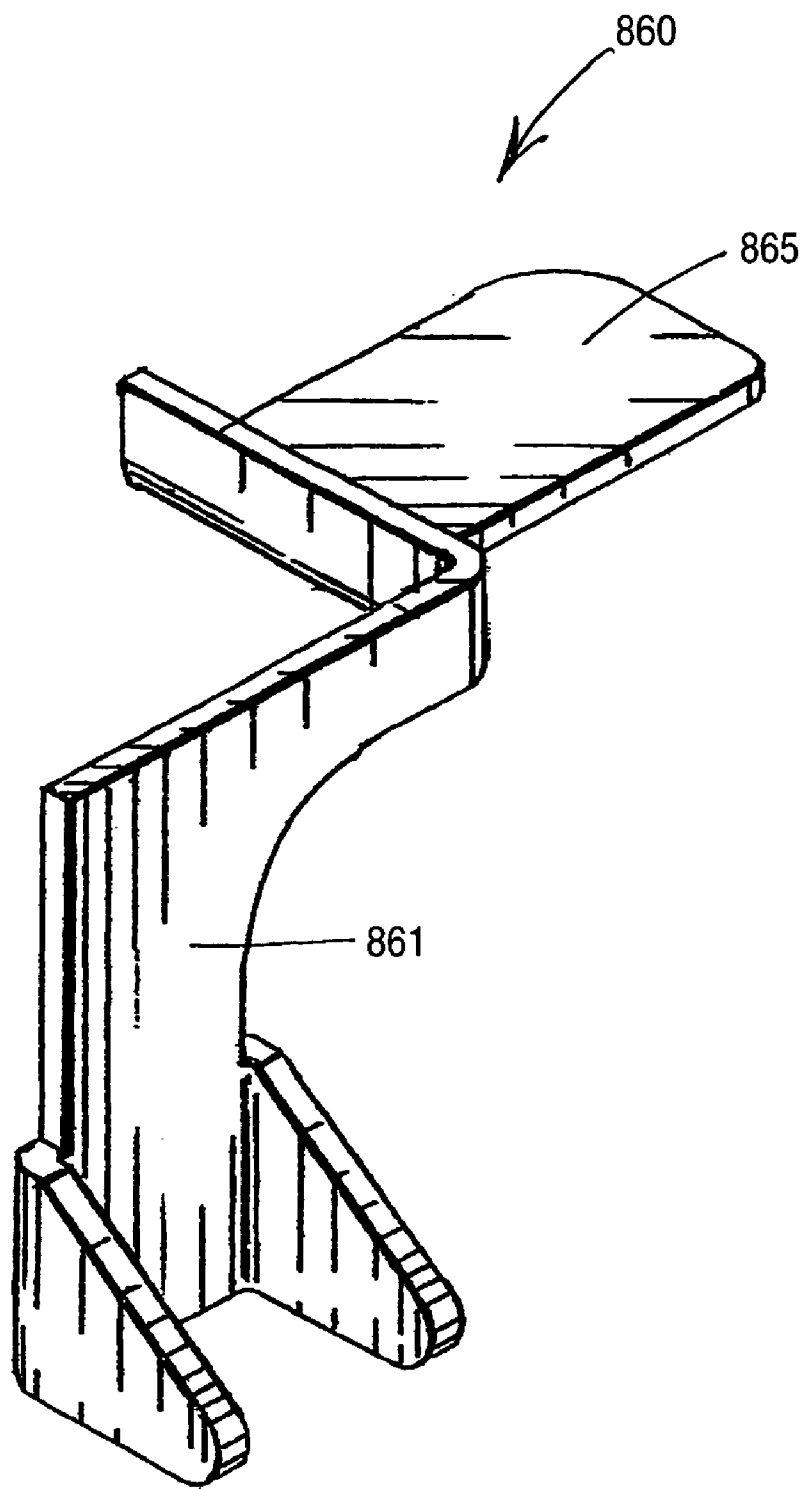

FIG. 89

CLUSTER BOX MAIL DELIVERY UNIT HAVING SECURITY FEATURES

PRIORITY

[0001] This application makes reference to and claims priority to provisional application 60/583,419, entitled, CLUSTER BOX MAIL DELIVERY RECEPTACLES, filed Jun. 29, 2004, the disclosure of which is incorporated herein by reference in its entirety.

FIELD OF THE INVENTION

[0002] The present invention relates generally to mail and parcel delivery receptacles of the general type referred to by the U.S. Postal Service (USPS) as “cluster box units.” More particularly, a cluster box unit, or “CBU” as it often is called, typically takes the form of a free-standing structure having a protective outer cabinet or enclosure, the interior of which can be accessed by USPS personnel by unlocking and opening one or a pair of so-called “master loading doors” that define a majority of the front face of a CBU.

BACKGROUND OF THE INVENTION

[0003] In a cluster box unit of the type having a left master loading door (LMLD) and a right master loading door (RMLD), the left side of the left master loading door usually is coupled by a left hinge to the left side of the enclosure of the CBU, and the right side of the right master loading door usually is coupled by a right hinge to the right side of the enclosure of the CBU. When the LMLD and RMLD are unlocked and pivoted to their fully open positions, substantially unobstructed access is provided to the interior of the CBU so that USPS personnel can insert mail and parcels into delivered mail and delivered parcel compartments arranged in left and right “stacks.” When the master loading doors are pivoted to their closed positions and locked, access to individual ones of the delivered mail and parcel compartments is gained by unlocking individual mail and parcel compartment doors that comprise door-within-a-door elements of the master loading doors.

[0004] Stated in another way, each delivered mail compartment and each delivered parcel compartment has its own, individual door, and these individual doors are elements of the left and right master loading doors—elements that normally are locked in closed positions so they pivot together with other elements of the master loading doors between closed and open positions of the master loading doors. Access to individual delivered mail compartments can be had by the customers, tenants or so-called “postal patrons” to whom the delivered mail compartments have been assigned when the postal patrons insert and turn individually assigned keys (that have been provided to them by the USPS or by managerial staff of apartment complexes, condominiums and the like) into locks found on the doors of delivered mail compartments so the doors can be opened to permit removal of compartment contents, thereafter the doors are closed and relocked, and the keys thereto removed by the postal patrons. A postal patron opens one of the delivered parcel compartments only when he or she finds a key to a delivered parcel compartment in his or her delivered mail compartment—a key that has been placed in the delivered mail compartment of the postal patron by a USPS delivery person who has inserted into a delivered parcel

compartment one or more parcels (that will not fit in the patron’s delivered mail compartment)—a key that can be used to open (on a onetime basis) the parcel compartment where the patron’s parcel or parcels are waiting to be retrieved.

[0005] Within the interior of a CBU of the type having left and right master loading doors, are left and right shelved cabinet assemblies that define the left and right stacks of mail and parcel compartments, respectively. The left stack of compartments is separated from the right stack of compartments by a vertically extending central structure which prevents items from the left compartments from being mixed with items from the right compartments, and vice versa. Latch and lock components for retaining the left and right master loading doors closed and locked often are connected to the central structure which couples the left and right shelved cabinet assemblies that define the left and right stacks of delivered mail and delivered parcel compartments.

[0006] The interior of a cluster box unit also usually has a compartment for temporarily holding “outgoing mail,” namely mail that is to be collected and processed by USPS personnel for delivery to other addresses and locations. Postal patrons who have outgoing mail to be collected and processed by the USPS may insert their outgoing mail into the outgoing mail compartment through a slot (that usually is protected by a louver) formed through one of the master loading doors, often the right master loading door.

[0007] A variety of locking systems and lock components have been proposed for retaining the master loading doors of a CBU closed and locked against unauthorized access (i.e., the master loading doors are only to be opened by authorized USPS personnel), and for retaining in closed and locked positions the individual door-within-a-door closures that provide individual access to the various delivered mail, delivered parcel and outgoing mail compartments of the CBU. Some CBU proposals employ outgoing mail compartment doors that are especially sturdy and resistant to attack, and that are held closed by a lock mechanism installed thereon by USPS personnel that can be unlocked by one of a group of restricted access USPS keys. These “hardened” outgoing mail compartment doors (sometimes referred to as “delivery doors” or as “collection doors”), when unlocked and opened, not only permit outgoing mail to be removed from the associated outgoing mail compartment but also permit the latches of the master loading doors to be released so the master loading doors can be opened to enable USPS personnel to insert mail and parcels into the delivered mail and delivered parcel compartments.

[0008] When a parcel is inserted into one of the delivered parcel compartments, the USPS delivery person locks the associated parcel door and inserts the key of the parcel door into the delivered mail compartment of the postal patron to whom the parcel is addressed. When the postal patron finds a parcel door key in his or her delivered mail compartment, he or she uses the key to open the associated parcel compartment and retrieves the parcel. When a parcel door key is turned to unlock the door of a parcel compartment, the lock mechanism of the parcel door “traps” or retains the key and prevents the tenant from relocking the parcel door, which can only be locked by USPS personnel. Key retaining lock mechanisms designed for use with delivered parcel lockers in the manner just described are known.

[0009] Although a number of cluster box unit proposals have been approved by the USPS and have functioned satisfactorily where installed to serve the mail and parcel delivery needs of a wide variety of multi-unit dwelling facilities, a need nonetheless remains for cluster box units designed to provide improved and enhanced security, corrosion resistance and longevity of service—cluster box units that are stronger and more resistant to unauthorized entry while, at the same time, being formed from reasonably priced, relatively easy to assemble components that can be serviced, maintained and replaced with a minimum of down time when damaged due to normal wear and tear, accident, vandalism or attack are needed. In these and other factors that merit consideration during product design, prior art proposals have left room for improvement.

[0010] The present invention addresses these and other needs and objectives as will become apparent from the disclosure that follows.

[0011] It is accordingly a primary aspect of the invention to provide a cluster box units which incorporates a wide variety of features that enhance security and attack resistance while utilizing components that can be assembled quickly and easily, and that can be serviced as needed in order to keep the unit functioning properly throughout its service life that last many years. Included among the many features disclosed herein are protective enclosure improvements, internal cabinetry improvements, door, hinge and locking system improvements, and a host of other features that are not found in present day cluster box units—features that are intended to provide units that function smoothly throughout lengthy service lives, that resist corrosion, offer good appearances, and that shield mail and parcels from inclement weather and from unauthorized access or attack.

[0012] The cluster box unit provides outgoing mail compartment doors that are heavily constructed and rigidly reinforced, with the locks carried thereon protectively shielded, and with the extensible bolts of these locks being engaged by brackets that not only lock the outgoing mail compartment doors but also the master loading doors of the cluster box units.

[0013] Master loading doors are provided with hinges that extend the full height of the doors—hinges that are defined by pivotally interfitting elements of extrusions that very sturdily mount the master loading doors, that prevent prying or bending the doors in the vicinities of their hinges. The interfitting elements of the hinge extrusions also permit the doors to be installed on their surrounding door frames quickly and easily, and permit one or both of the master loading doors to be quickly and easily removed for service or replacement when necessary.

SUMMARY OF THE INVENTION

[0014] The foregoing needs have been satisfied to a great extent by the present invention wherein, in one aspect an apparatus and method is provided that incorporates a protective enclosure, internal cabinetry, door, hinge and locking system, and a host of other features that are not found in present day cluster box units—features that are intended to provide units that function smoothly throughout lengthy service lives, that resist corrosion, offer good appearances, and that shield mail and parcels from inclement weather and from unauthorized access or attack.

[0015] Another aspect of the invention provides outgoing mail compartment doors that are heavily constructed and rigidly reinforced, with the locks carried thereon protectively shielded, and with the extensible bolts of these locks being engaged by brackets that not only lock the outgoing mail compartment doors but also the master loading doors of the cluster box units.

[0016] Yet another aspect of the invention provides master loading doors having hinges that extend the full height of the doors—hinges that are defined by pivotally interfitting elements of extrusions that very sturdily mount the master loading doors, that prevent prying or bending the doors in the vicinities of their hinges. The interfitting elements of the hinge extrusions also permit the doors to be installed on their surrounding door frames quickly and easily, and permit one or both of the master loading doors to be quickly and easily removed for service or replacement when necessary.

[0017] In accordance with the invention, one aspect of the invention provides a cluster box mail delivery unit comprising an enclosure comprising two sidewalls, a top wall, a bottom wall, a front face, and a back face; at least two door assemblies on the front face of the enclosure, wherein each door assembly comprises a first inner edge and a first outer edge; at least one compartment door within each door assembly configured to pivot relative to the door assembly; and at least one fastening member formed along the first inner edge of each door assembly for securing the at least two door assemblies in a closed position, wherein each door assembly pivots relative to the enclosure along the first outer edge of each door assembly, each fastening member further comprising an upright portion, an extending portion, and a hook portion, each upright portion further comprising a second inner edge and a second outer edge, and each hook portion protruding outward from the second inner edge of the upright portion and engaging with an opposing hook portion, forming a gap between at least one second inner edge of the upright portion and the engaged hook portions.

[0018] Another aspect of the invention provides a fastening apparatus for securing at least two door assemblies of a cluster box mail delivery unit comprising an upright portion; an extending portion; and a hook portion; wherein the upright portion comprises an inner edge and an outer edge; and wherein each hook portion protrudes outward from the inner edge of the upright portion and engages with an opposing hook portion, forming a gap between at least one inner edge of the upright portion and the engaged hook portions.

[0019] Yet another aspect of the invention provides a door with a rugged door hinge for pivotally mounting the door in a cluster box mail delivery unit, comprising an interfitting upright extrusion mounted on a door frame, wherein the extrusion has a complexly curved groove; a curved formation located on the door upright and extending into said complexly curved groove of the frame extrusion, and an elongated hinge rod extending through the full longitudinal length of the door, wherein the hinge further extends over the full longitudinal length of the door.

[0020] Yet still another aspect of the invention provides a master loading door of a cluster box mail delivery unit having a hinge pivotally mounting the door, comprising an interfitting upright extrusion on the door frame wherein the upright extrusion has a complexly curved groove; a curved

formation of the door upright and extending into the curved groove of the upright extrusion; and an elongated hinge rod extending through the full longitudinal height of the door, wherein the hinge further extends over the full longitudinal length of the door.

[0021] Additional aspects and advantages of the invention will be set forth in part in the description which follows, and in part will be obvious from the description, or may be learned by practice of the invention. The aspects and advantages of the invention will be realized and attained by means of the elements and combinations particularly pointed out in the appended claims.

[0022] It is to be understood that both the foregoing general description and the following detailed description are exemplary and explanatory only and are not restrictive of the invention, as claimed.

[0023] The accompanying drawings, which are incorporated in and constitute a part of this specification, illustrate several embodiments of the invention and together with the description, serve to explain the principles of the invention.

BRIEF DESCRIPTION OF THE DRAWINGS

[0024] FIG. 1 is a perspective view showing front, top and right side portions of one form of cluster box unit (CBU) mail delivery receptacle.

[0025] FIG. 2 is a front elevational view of FIG. 1 without the support pedestal.

[0026] FIG. 3 is a perspective view showing front, top and right side portions of a second embodiment of cluster box unit mail delivery receptacle.

[0027] FIG. 4 is a front elevational view of FIG. 3 without the support pedestal.

[0028] FIG. 5 is a perspective view showing front, top and right side portions of a third embodiment of cluster box unit mail delivery receptacle.

[0029] FIG. 6 is a front elevational view of FIG. 5 without the support pedestal.

[0030] FIG. 7 is a perspective view showing front, top and right side portions of a fourth embodiment of cluster box unit mail delivery receptacle.

[0031] FIG. 8 is a front elevational view of FIG. 7 without the support pedestal.

[0032] FIG. 9 is a perspective view of the CBU of FIGS. 1 and 2 with left and right master loading doors thereof in open positions, with door-within-a-door elements of the master loading doors locked closed so as to pivot with other elements of the master loading doors when the master loading doors move between their closed and open positions.

[0033] FIG. 10 is a perspective view on an enlarged scale showing selected front and left portions of the left master loading door of the CBU of FIGS. 1 and 2.

[0034] FIG. 11 is a perspective view on an enlarged scale showing selected front and left portions of the right master loading door of the CBU of FIGS. 1 and 2.

[0035] FIG. 12 is a perspective view showing selected front and right portions of the right master loading door of

the CBU of FIGS. 1 and 2 including a hooded louvered mail slot through which outgoing mail is inserted into an outgoing mail compartment located behind the right master loading door.

[0036] FIG. 13 is a cross-sectional view on an enlarged scale taken along line 13-13 of FIG. 2 with the left master loading door in its closed, locked position.

[0037] FIG. 14 is a cross-sectional view on an enlarged scale taken along line 14-14 of FIG. 9 with the left master loading door in its fully open position.

[0038] FIG. 15 is a perspective view of a rectangular frame structure that surrounds the master loading doors of the CBU of FIGS. 1-2.

[0039] FIGS. 16-19 are cross-sectional views taken along lines 16-16, 17-17, 18-18 and 19-19 of FIG. 15.

[0040] FIG. 20 is an exploded view on an enlarged scale showing components of a corner joint of the rectangular frame structure of FIG. 15.

[0041] FIG. 21 is a perspective view showing in assembled form the components of FIG. 20.

[0042] FIG. 22 is a perspective view of portions of the master loading doors of the CBU of FIGS. 1-2 showing how the depicted door portions come closely together when the left and right master loading doors are into engaging relationship when closed.

[0043] FIG. 23 is a cross-sectional view on an enlarged scale taken along line 23-23 of FIG. 22.

[0044] FIG. 24 is a schematic top view showing portions of the left and right master loading doors pivoted to an open position.

[0045] FIG. 25 is an exploded perspective view showing door-within-a-door elements of the right master loading door of the CBU of FIGS. 1-2 separated from a frame assembly of the right master loading door, and showing a hinge rod for pivotally coupling the door-within-a-door elements to the frame assembly.

[0046] FIG. 26 is a perspective view on an enlarged scale of an upper right corner region of the frame assembly of FIG. 25, with the view permitting a recess to be seen that carries a hex nut threaded onto an upper end region of the hinge rod to secure the hinge rod in assembled position.

[0047] FIG. 27 is an exploded perspective view showing selected portions of the frame assembly of the right master loading door together with portions of a first form of compartment door that may be used with the frame assembly, with the compartment door in closed position in a forwardly facing recess defined by elements of the frame assembly.

[0048] FIG. 28 is a cross-sectional view taken along line 28-28 of FIG. 27.

[0049] FIG. 29 is a cross-sectional view taken along line 29-29 of FIG. 27.

[0050] FIG. 30 is an exploded perspective view showing selected portions of the frame assembly of the left master loading door together with portions of the first form of compartment door in closed position in a forwardly facing recess defined by elements of the frame assembly.

[0051] FIG. 31 is a cross-sectional view taken along line 31-31 of FIG. 30.

[0052] FIG. 32 is a cross-sectional view taken along line 32-32 of FIG. 30.

[0053] FIG. 33 is an exploded perspective view showing selected portions of the frame assembly of the right master loading door together with portions of a second form of compartment door that may be used with the frame assembly, with the compartment door in closed position in a forwardly facing recess defined by elements of the frame assembly.

[0054] FIG. 34 is a cross-sectional view taken along line 34-34 of FIG. 33.

[0055] FIG. 35 is a cross-sectional view taken along line 35-35 of FIG. 33.

[0056] FIG. 36 is an exploded perspective view showing selected portions of the frame assembly of the left master loading door together with portions of the second form of compartment door in closed position in a forwardly facing recess defined by elements of the frame assembly.

[0057] FIG. 37 is a cross-sectional view taken along line 37-37 of FIG. 36.

[0058] FIG. 38 is a cross-sectional view taken along line 38-38 of FIG. 36.

[0059] FIG. 39 is a perspective view showing selected portions of a master loading door frame assembly including four types of horizontally extending bars that may be employed as elements of the frame assembly.

[0060] FIG. 40 is a cross-sectional view taken along line 40-40 of FIG. 39.

[0061] FIG. 41 is a cross-sectional view taken along line 41-41 of FIG. 39.

[0062] FIG. 42 is a cross-sectional view taken along line 42-42 of FIG. 39.

[0063] FIG. 43 is a cross-sectional view taken along line 43-43 of FIG. 39.

[0064] FIG. 44 is a perspective view showing portions of one of the horizontal bars of FIGS. 40, 41 and 43 carrying a weather strip closed into engagement with a shelf front of one the compartments of the CBU of FIGS. 1-2.

[0065] FIG. 45 is a cross-sectional view taken along line 45-45 of FIG. 44.

[0066] FIG. 46 is a perspective view showing portions of the horizontal bar of FIG. 42 carrying a weather strip closed into engagement with a strengthened shelf front of one the compartments of the CBU of FIGS. 1-2.

[0067] FIG. 47 is a cross-sectional view taken along line 47-47 of FIG. 46.

[0068] FIG. 48 is a perspective view showing portions of one of the delivered mail compartment doors that forms a door-within-a-door element of one of the left and right master loading doors of the CBU of FIGS. 1-2.

[0069] FIG. 49 is a top view of FIG. 48.

[0070] FIG. 50 is a left end view of FIG. 48.

[0071] FIG. 51 is a right end view of FIG. 48.

[0072] FIG. 52 is a cross-sectional view taken along line 52-52 of FIG. 48.

[0073] FIG. 53 is a cross-sectional view taken along line 53-53 of FIG. 48.

[0074] FIG. 54 is a perspective view on an enlarged scale of a cam lock cam and portions of a strike that can be engaged by the cam to lock in closed position one of the delivered mail compartment doors of the CBU of FIGS. 1-2.

[0075] FIG. 55 is a cross-sectional view taken along line 55-55 of FIG. 54.

[0076] FIG. 56 is a side view of the cam and a cross-sectional view of the strike taken along line 56-56 of FIG. 55, but with latching portions of the cam extending through an elongate slot-like receiving opening of the strike, as the cam appears when pivoted to its latched position by a cam lock of a delivered mail compartment door.

[0077] FIG. 57 is a view thereof similar to FIG. 56 but with the cam turned a quarter-turn to disengage the strike, as the cam appears when pivoted to its unlatched position by a cam lock of a delivered mail compartment door.

[0078] FIG. 58 is a perspective view showing front and left portions of the smaller of two delivered parcel compartment doors that forms a door-within-a-door element of one of the master loading doors of the CBU of FIGS. 1-2.

[0079] FIG. 59 is a cross-sectional view taken along line 59-59 of FIG. 58.

[0080] FIG. 60 is a perspective view showing rear and right portions of the larger of two delivered parcel compartment doors that forms a door-within-a-door element of one of the master loading doors of the CBU of FIGS. 1-2.

[0081] FIG. 61 is a rear elevational view of portions of a delivered parcel compartment door showing a guard assembly that may be used to protectively enclose components of one form of locking system for retaining the parcel door in closed position.

[0082] FIG. 62 is a rear elevational view of portions of a delivered parcel compartment door showing a different guard assembly that may be used to protectively enclose components of another form of locking system for retaining the parcel door in closed position.

[0083] FIG. 63 is a perspective view of one embodiment of locking system for delivered parcel compartment doors, with a cam thereof pivoted to a latched position.

[0084] FIG. 64 is another perspective view thereof, but with cam thereof pivoted to an unlatched position.

[0085] FIG. 65 is yet another perspective view thereof, with the cam pivoted to a latched position wherein latching portions of the cam extend through an elongate slot-like receiving formation of a strike.

[0086] FIG. 66 is a perspective view similar to FIG. 65 showing an alternate form of locking system for delivered parcel compartment doors, with a pair of linkage connected cams thereof pivoted to latched positions wherein latching portions of the cams extend through elongate slot-like receiving formations of a strike.

[0087] FIG. 67 is a perspective view showing front, top and left end portions of an outgoing mail compartment door which serves as a door-within-a-door element of the right master loading door of the CBU of FIGS. 1-2, with a bolt of a USPS lock mounted on the back of the door retracted.

[0088] FIG. 68 is a top view of FIG. 67.

[0089] FIG. 69 is a left end view of FIG. 67.

[0090] FIG. 70 is a right end view of FIG. 67.

[0091] FIG. 71 is a perspective view showing rear, top and left end portions of FIG. 67, with the bolt of the door-carried lock retracted, and with a strike that can be engaged by the bolt of the door-carried lock spaced from the rear of the door, as occurs when the door is only slightly opened, or when the door is being pivoted toward a closed position.

[0092] FIG. 72 is a perspective view similar to FIG. 71 but with the bolt of the door-carried lock extended through a receiving opening of the strike, as occurs when the door is locked in closed position.

[0093] FIG. 73 is a perspective view showing front, top and left side portions of a protective outer enclosure of the CBU of FIGS. 1-2.

[0094] FIG. 74 is a right side view of FIG. 73.

[0095] FIG. 75 is a cross-sectional view taken along line 75-75 of FIG. 73.

[0096] FIG. 76 is a cross-sectional view on an enlarged scale taken along line 76-76 of FIG. 73.

[0097] FIG. 77 is a cross-sectional view on an enlarged scale taken along line 77-77 of FIG. 73.

[0098] FIG. 78 is a cross-sectional view on an enlarged scale taken along line 78-78 of FIG. 73.

[0099] FIG. 79 is a cross-sectional view taken along line 79-79 of FIG. 73.

[0100] FIG. 80 is a perspective view showing front and right portions of the CBU of FIGS. 1-2 with the delivered mail compartment doors, the delivered parcel compartment doors and the top of the protective outer enclosure thereof removed to permit interior left and right shelved cabinet features of the CBU to be seen.

[0101] FIG. 81 is an exploded perspective view on an enlarged scale showing features of the left and right shelved cabinets of FIGS. 80.

[0102] FIG. 82 is a top view of left and right shells of the shelved cabinets of FIG. 80, and showing front and rear connection members extending therebetween.

[0103] FIG. 83 is a perspective view, on an enlarged scale, of one of the rear connection members that extends between rear portions of the left and right shells.

[0104] FIG. 84 is a perspective view, on an enlarged scale, of portions of a front connection member that extends between front portions of the left and right shells.

[0105] FIG. 85 is a perspective view of portions of upper and lower portions of the left and right shells coupled by the front and rear connection members.

[0106] FIG. 86 is a perspective view showing in broken lines portions of the CBU of FIGS. 1-2, and in solid lines

latching elements carried on the front connection member and on the master loading doors that cooperate to latch the master loading doors in closed position.

[0107] FIG. 87 is a front elevational view on an enlarged scale of latching elements of FIG. 86 that are carried on the front connection member.

[0108] FIG. 88 is a perspective view showing central portions of the latching elements of FIG. 87.

[0109] FIG. 89 is a perspective view showing one of the components of the latching elements of FIG. 88.

DETAILED DESCRIPTION OF THE INVENTION

[0110] Embodiments of the invention provide an apparatus and method which incorporates a protective enclosure, internal cabinetry, door, hinge and locking system. Reference will now be made in detail to the present embodiments of the invention, examples of which are illustrated in the accompanying drawings. Wherever possible, the same reference numbers will be used throughout the drawings to refer to the same or like parts.

[0111] Four types of multiple-box mail delivery receptacles are depicted in sequence in FIGS. 1, 3, 5 and 7. These multiple box receptacles, referred to in the art as "cluster box units" or individually as a "CBU," are indicated generally by the numerals 100, 1100, 2100, 3100. The CBU mail delivery receptacles 100, 1100, 2100, 3100 have generally rectangular protective outer cabinets 110, 1110, 2110, 3110 that are supported atop pedestal type stands 120, 1120, 2120, 3120. In FIGS. 2, 4, 6 and 8, the cluster box units 100, 1100, 2100, 3100 are depicted without their stands.

[0112] Because the four cluster box unit mail delivery receptacles 100, 1100, 2100, 3100 are assembled from components that are quite similar (i.e., components that tend to differ only in size if the components are not precisely identical), the construction and operation of all four of these cluster box units will be apparent from the description that follows even though, in some instances, the description concentrates principally on features of a selected one of the cluster box units, namely the unit 100.

[0113] In the drawings and in the description that follows, "corresponding reference numerals" (i.e., reference numerals that differ by magnitudes of one, two or three thousand) are used to designate components of the cluster box units 100, 1100, 2100, 3100 that correspond in function—many of which components differ only slightly in dimension unless they are, in fact, completely identical. Utilizing in the drawings reference numerals that correspond to designate components that correspond in function, permits corresponding components to be identified so their corresponding functions will be understood without requiring that the text include repetitive descriptions. Thus, unless explained to the contrary, if the reference numeral 101 is used to designate a component of the cluster box unit 100, the reader should understand that usages of the corresponding numerals 1101, 2101, 3101 (where found in the drawings) designate components of the cluster box units 1100, 2100, 3100 that correspond in function to the component 101 of the cluster box unit 100; and, unless explained to the contrary, if the reference numeral 102 is used to designate a component of the cluster box unit 100, the reader should understand that

usages of the corresponding numerals **1102**, **2102**, **3102** (where found in the drawings) designate components of the cluster box units **1100**, **2100**, **3100** that correspond in function to the component **102** of the cluster box unit **100**; and so on, for other so-called “corresponding” reference numerals found in the drawings that differ by magnitudes of one, two or three thousand.

[0114] Referring variously to **FIGS. 1-8** (an expression that will be understood by the reader to mean that some views, such as **FIGS. 1-2**, should be referred to insofar as features of the CBU **100** are concerned; that other views, such as **FIGS. 3-4**, should be referred to insofar as features of the CBU **1100** are concerned; that other views, such as **FIGS. 5-6**, should be referred to insofar as features of the CBU **2100** are concerned; and, that still other views, such as **FIGS. 7-8**, should be referred to insofar as features of the CBU **3100** are concerned), the cabinets **110**, **1110**, **2110**, **3110** have left front door assemblies **130**, **1130**, **2130**, **3130** and right front door assemblies **140**, **1140**, **2140**, **3140**. U.S. Postal Service (USPS) personnel commonly refer to the left front door assemblies **130**, **1130**, **2130**, **3130** as “left master loading doors,” and to the right front door assemblies **140**, **1140**, **2140**, **3140** as “right master loading doors.”

[0115] Various optional features may be incorporated in the design of the protective outer enclosures **110**, **1110**, **2110**, **3110** and/or in the design of other components of the cluster box units **100**, **1100**, **2100**, **3100** such as the master loading doors **130**, **140**, **1130**, **1140**, **2130**, **2140**, **3130**, **3140** to alter exterior and interior appearances of the CBUs **100**, **1100**, **2100**, **3100** and their components. Likewise, various optional functional, utilitarian, structural and operational features also may be incorporated into the CBUs **100**, **1100**, **2100**, **3100**

[0116] The left master loading doors **130**, **1130**, **2130**, **3130** are provided with hinges (indicated generally by the numerals **151**, **1151**, **2151**, **3151**) along their left sides, and the right master loading doors **140**, **1140**, **2140**, **3140** are provided with hinges (indicated generally by the numerals **161**, **1161**, **2161**, **3161**) along their rights sides, so that master loading doors may be pivoted away from door closed positions depicted variously in **FIGS. 1-8** to door open positions that provide unobstructed access to the interiors of the cabinets **110**, **1110**, **2110**, **3110**. For example, reference is made to **FIG. 9** wherein the master loading doors **130**, **140** of the cluster box unit **100** are shown pivoted to fully open positions that permit mail to be delivered into left and right mail compartments designated by numerals **131**, **141**, and so that parcels too large to fit into the mail delivery compartments **131**, **141** can be delivered into left and right parcel compartments designated by numerals **133**, **143**.

[0117] Referring still to **FIG. 9**, the interior of the CBU **100** also is provided with an outgoing mail compartment **145** at a location situated between an upper region of the right side of the interior of the CBU **100** where the right mail delivery compartments **141** are found, and a lower region of the right side of the interior of the CBU **100** where the right parcel delivery compartment **143** is found. So-called “outgoing mail,” namely mail that is to be collected and processed by USPS personnel for delivery to other addresses and locations just as though it had been deposited in and collected from a conventional USPS mail collection box, can be inserted into the outgoing mail compartment **145**

through a mail slot **129** (see **FIGS. 11 and 12**) of a louvered mail slot structure **150** that is defined by components of the right master loading door **140**.

[0118] The left and right delivered mail compartments **131**, **141** (depicted in **FIG. 9**) may be accessed by opening delivered mail compartment doors **220** when the master loading doors **130**, **140** are closed and locked. The delivered mail compartment doors **220** have door-within-a-door relationships with the master loading doors **130**, **140** (i.e., the doors **220** are elements of the master loading doors **130**, **140**—elements that can pivot relative to the frameworks of the master loading doors, such as the framework **180** depicted in **FIG. 26**). A discussion of features of the preferred form of construction for the doors **220** is provided later herein in conjunction with **FIGS. 29-38** and **48-52**. A discussion of locking systems for the doors **220** is provided later herein in conjunction with **FIGS. 55-57**.

[0119] The left and right delivered parcel compartments **133**, **143** (depicted in **FIG. 9**) may be accessed by opening the delivered mail compartment doors **230** when the master loading doors **130**, **140** are closed and locked. The delivered mail compartment doors **230** have door-within-a-door relationships with the master loading doors **130**, **140** (i.e., the doors **230** are elements of the master loading doors **130**, **140**—elements that can pivot relative to the frameworks of the master loading doors, such as the framework **180** depicted in **FIG. 26**). A discussion of features of the preferred form of construction for the doors **230** is provided later herein in conjunction with **FIGS. 33-38** and **58-62**.

[0120] The outgoing mail compartment **145** (depicted in **FIG. 9**) may be accessed by opening an outgoing mail compartment door **240**. The outgoing mail compartment door **240** has a door-within-a-door relationship with the right master loading door **140**, and can pivot relative to the framework **180** of the right master loading door **140** (see **FIG. 26**). A discussion of features of the preferred form of construction for the door **240**, and of a locking system preferably utilized to lock the door **240**, is provided later herein in conjunction with **FIGS. 67-72**.

[0121] Again, referring to **FIG. 9**, located to the left of the outgoing mail compartment **145** and situated between an upper region of the left side of the interior of the CBU **100** where the left mail delivery compartments **131** are found and a lower region of the left side of the interior of the CBU **100** where the left parcel delivery compartment **133** is found, is a narrow spare compartment **135** that may be used by USPS personnel for a variety of purposes, for example to retain maintenance records pertaining to the CBU **100**, or for other purposes such as storing spare mail and parcel door keys that may be needed as replacements for lost keys at some future time. The narrow spare compartment **135** provides a storage area that is secure from being accessed by those who make use of the left and right mail and parcel compartments **131**, **141**, **133**, **143** because, when the left and right master loading doors **130**, **140** are locked closed, the spare compartment **135** cannot be accessed from outside the CBU **100** through any of the openings formed through the master loading doors **130**, **140**.

[0122] Whereas the cluster box units **100**, **2100** have both left and right delivered parcel compartments served by left and right parcel doors **130**, **2130**, respectively, the cluster box unit **1100** has only a right delivered parcel compartment

served by a right parcel door **1130**, and the cluster box unit **3100** has only a left delivered parcel compartment served by a left parcel door **3130**. As those who are skilled in the art will readily understand, other cluster box unit configurations (employing delivered mail compartments and delivered parcel compartments that differ in size, number and location from those depicted in the drawings hereof) are possible—configurations that embody many of the inventive features hereof. For example, as a comparison of the cluster box units **100** and **1100** will illustrate, a plurality of delivered mail compartments can be substituted for one of the delivered parcel compartments, or vice versa; and, as a comparison of the cluster box units **2100**, **3100** will illustrate, the sizes of delivered mail compartments and of other features of the cluster box units disclosed herein can differ while still employing many of the same inventive features.

[0123] A horizontally extending extrusion **137** (see **FIGS. 1, 2 and 10**) of the left master loading door **130** serves to cover the front of the spare compartment **135** when the left door **130** is closed. The extrusion **137** preferably is configured to provide an exterior appearance like that which is afforded by a corresponding horizontally extending extrusion **147** of the right master loading door **140**—it being seen in **FIGS. 11 and 12** that the right master loading door extrusion **147** has an elongate, slot-like opening formed therethrough, namely the opening of the slot structure **150** through which outgoing mail is inserted into the outgoing mail compartment **145**. A hood element **149** depicted in **FIGS. 1, 2 and 12**, shields the slot **150** to prevent rain and snow from passing there-through.

[0124] Referring to **FIGS. 1-8**, it will be seen that the cluster box units **100**, **1100**, **2100**, **3100** have substantially identical louvered slot structures **150**, **1150**, **2150**, **3150** defined cooperatively by identical right master loading door extrusions **147**, **1147**, **2147**, **3147** and identical hood elements **149**, **1149**, **2149**, **3179**. It should be noted that the features of and the appearance and construction of the louvered mail slot structures **150**, **1150**, **2150**, **3150**; of the identical extrusions **137**, **147**, **1137**, **1147**, **2137**, **2147**, **3137**, **3147**; and of the identical hood elements **149**, **1149**, **2149**, **3149** are not limited to those shown in **FIGS. 1-8**.

[0125] Referring principally to **FIGS. 2, 4, 6 and 8**, the left master loading doors **130**, **1130**, **2130**, **3130** have rectangular configurations bordered by left uprights **132**, **1132**, **2132**, **3132**; right uprights **134**, **1134**, **2134**, **3134**; top bars **136**, **1136**, **2136**, **3136**; and bottom bars **138**, **1138**, **2138**, **3138**. The right master loading doors **140**, **1140**, **2140**, **3140** have rectangular configurations bordered by right uprights **142**, **1142**, **2142**, **3142**; left uprights **144**, **1144**, **2144**, **3144**; top bars **146**, **1146**, **2146**, **3146**; and bottom bars **148**, **1148**, **2148**, **3148**.

[0126] The left uprights **132**, **1132**, **2132**, **3132** of the left master loading doors **130**, **1130**, **2130**, **3130** preferably are defined by extrusions of identical cross-section that extend substantially the full heights of the left master loading doors **130**, **1130**, **2130**, **3130**. The left upright extrusions **132**, **1132**, **2132**, **3132** which are of uniform cross-section along their lengths, define halves of hinges **151**, **1151**, **2151**, **3151** that pivotally mount the left master loading doors **130**, **1130**, **2130**, **3130** for pivotal movement (about an axis that is designated by the numeral **51** in **FIGS. 13, 14, 18 and 24**) between their closed positions as depicted in **FIGS. 1-8** and

13, and open positions of the left master loading door **130** depicted in **FIGS. 9, 14 and 24**. The right master loading doors **140**, **1140**, **2140**, **3140** are mounted for pivotal movement in the same way (about an axis that is designated by the numeral **52** in **FIGS. 19 and 24**) between their closed positions as depicted in **FIGS. 1-8**, and open positions depicted in **FIGS. 9 and 24**.

[0127] Referring to **FIG. 13** wherein a cross-section of the left upright extrusion **132** is shown, the other half of the hinge that pivotally mounts the left master loading door **130** is defined by an extrusion **152** which has a groove **31** of complex cross-sectional configuration (also shown in **FIG. 18**) that receives in an interfitting relationship a curved formation **32** of the left master loading door upright extrusion **132** in a manner that permits the left master loading door **130** to pivot about the axis **51** (**FIGS. 13, 14 and 24**) between the closed position depicted in **FIGS. 1-8 and 13**, and open positions depicted in **FIGS. 9, 14 and 24**. Other views that also show the curved formation **32** include **FIGS. 30, 32, 36 and 38**.

[0128] Referring to **FIGS. 2, 4, 6 and 8**, it will be seen that left door frame upright extrusions **152**, **1152**, **2152**, **3152** (all having the same cross-section as is depicted in **FIGS. 13, 14 and 18** where the cross-section of the extrusion **152** is shown) extend the full height along the left sides of the left master loading doors **130**, **1130**, **2130**, **3130** to cooperate with the extrusions **132**, **1132**, **2132**, **3132** to define the hinges **151**, **1151**, **2151**, **3151** that extend for the full heights of the left master loading doors **130**, **1130**, **2130**, **3130**.

[0129] Likewise, referring to **FIGS. 2, 4, 6 and 8**, it will be understood that full-height door hinges **161**, **1161**, **2161**, **3161** are defined by interfitting extrusions **142/162** (see **FIG. 19** where the cross-section of the extrusion **162** is shown as having a complexly curved groove **41** that is a mirror image reversal of the cross-section of the curved groove **31** shown in **FIG. 18**), **1142/1162**, **2142/2162** and **3142/3162** that have cross sections that are mirror images of the cross-sections of the interfitting extrusions **132**, **152** depicted in **FIGS. 13, 14**—and which permit the right master loading doors **140**, **1140**, **2140**, **3140** to pivot open just as the left master loading door **130** is depicted as pivoting open due to relative movement of the extrusions **132**, **152** in **FIG. 11** (see, for example, **FIG. 24** wherein the right master loading door **140** is shown pivoted about an axis **52** to an open position).

[0130] A curved formation **42** of the right master loading door upright **142** that extends into the curved groove **41** of the frame extrusion **162** is shown in **FIGS. 26, 27, 29, 33 and 35** to have a cross-section that is a mirror image reversal of the cross-section of the curved formation **32** of the left master loading door upright **132**.

[0131] Referring to **FIG. 15**, the left and right uprights **152**, **162** which form elements of the hinges **151**, **161** that pivotally mount the left and right master loading doors **130**, **140** are two of the four elements of a rectangular frame **160** that surrounds the master loading doors **130**, **140**. Top and bottom bars **166**, **168** of generally F-shaped cross-section complete the frame **160**. In **FIGS. 16-19** the cross-sections of the four frame elements **152**, **162**, **166**, **168** are depicted.

[0132] In **FIG. 20** an exploded view is provided showing how one of the four corner junctures of the frame **160** is

formed, namely the corner juncture of the frame elements **152, 166** which is secured by screws **127** that extend through holes formed in the top bar **166** and are threaded into generally circular formations **128** of the cross-section of the upright **152**. In **FIG. 21**, a completed corner juncture of the frame elements **152, 166** is depicted. The other three corner junctures of the frame **160** are formed in the same manner, and the cluster box units **1100, 2100, 3100** have similarly configured frames **1160, 2160, 3160** (see **FIGS. 4, 6, 8**) formed by top and bottom bars **1166, 1168, 2166, 2168, 3166, 3168** that join with the uprights **1152, 1162, 2152, 2162, 3156, 3162**.

[0133] The right upright **134** of the left master loading door **130**, and the left upright **144** of the right master loading door **140** are configured to move into close association with each other when the left master loading door **130** and the right master loading door **140** are pivoted to bring them to their closed positions, as depicted in **FIGS. 1, 2, 22** and **23**. Referring to **FIGS. 22-24**, it will be seen that the left upright **144** of the right master loading door **140** has a rearwardly turned hooked portion **170** that will be engaged by a forwardly turned hooked portion **171** of the right upright **134** of the left master loading door **130** such that even if a prybar or other pointed or edge tool is inserted into a space **173** (see **FIG. 23**) between the uprights **134, 144** of the master loading doors **130, 140** in an effort to pry the closed, locked master loading doors **130, 140** away from each other the hooked portions **170, 171** will remain sealed. While the hooked portions **170, 171** are effective in resisting attack, their presence does nothing to impede normal opening and closing of the master loading doors **130, 140**, as is depicted in **FIG. 24**.

[0134] Thus, if a pry bar (not shown) is inserted into the space **173** in an effort to widen the space **173**, the hooked portions **170, 171** will engage—which effectively strengthens the resistance of the CBU **100** to attack. Likewise, the fact that the space **173** is backed by a rightwardly extending portion **175** (see **FIG. 23**) of the upright **134**, and the fact that the wide front face **177** (see **FIG. 23**) of the upright **144** is rigidified by a box-like cross-section **176** also help to defeat and fend off attack if force is applied to the master loading doors **130, 140** in an attempt to gain entry to the interior of the CBU **100**.

[0135] Inasmuch as the master loading doors **1130, 1140, 2130, 2140, 3130, 3140** have uprights **1134, 1144, 2134, 2144, 3134, 3144** that are identical to the uprights **134, 144** depicted in **FIGS. 22-24**, the cluster box units **1100, 2100, 3100** also are resistant to attack if efforts are made to pry open the master loading doors **1130, 1140, 2130, 2140, 3130, 3140** from a closed configuration.

[0136] Referring to **FIG. 26**, elements of one of the master loading doors, namely the right master loading door **140** of the cluster box unit **100**, are shown. The master loading door **140** has a generally rectangular framework **180** defined by the right upright **142**, the left upright **144**, the top bar **146** and the bottom bar **148**—a framework that is rigidified and strengthened by the extrusion **147** that extends centrally between the uprights **142, 144**.

[0137] Referring to **FIGS. 11 and 12**, the extrusion **147** has a somewhat complex but generally C-shaped cross-section that is uniform along the full length of the extrusion **147** (except where the mail slot **129** opens through a central

upstanding web of the C-shaped cross-section of the extrusion **147**). Upper and lower legs of the C-shaped cross-section of the extrusion are provided with downwardly opening recesses **107** that also run the full length of the extrusion **147**. Upper portions of the recesses **107** are rounded and align with holes **108** formed through the uprights **142, 144** (in **FIG. 12**, the holes **108** that extend through the upright **142** can be seen; and, in **FIG. 11**, the holes **108** that extend through the upright **144** can be seen). Threaded fasteners, like the screws **127** depicted in **FIG. 20**, extend through the holes **108**, are threaded into the rounded upper end regions of the recesses **107**, and are tightened in place to clamp opposite end regions of the extrusion **147** into engagement with the uprights **142, 144**.

[0138] Referring still to **FIGS. 11 and 12**, because the uprights **142, 144** have bar-like formations **102, 104** that project toward each other along the full lengths of the uprights **142, 144**, opposite end regions of the extrusion **147** are provided with slots **103, 105** (the slot **103** can best be seen in **FIG. 11**; the slot **105** can best be seen in **FIG. 12**) to snugly receive the bar-like formations **102, 104**. The interengagement of the bar-like formations **102, 104** with the slots **103, 105** maintains proper alignment of front and rear surfaces of the extrusion **147** with front and rear surfaces of the uprights **142, 144**, and assists the extrusion **147** in rigidifying the framework **180** (**FIG. 25**) of the right master loading door **140**.

[0139] Referring to **FIG. 10**, the left master loading door **130** is similarly reinforced, rigidified and strengthened by the extrusion **137** which has the same C-shaped cross-section as the extrusion **147**, the same recesses **107** as the extrusion **147**, and the same slots (only the slot **105** is shown in **FIG. 10**) as the slots **103, 105** of the extrusion **147** for receiving bar-like formations **102, 104** of the uprights **132, 134** that are identical in configuration to the bar-like formations **102, 104** of the uprights **142, 144** of the right master loading door **140**.

[0140] Referring briefly to **FIG. 39** where upright portions and cross-bar elements that are common to the left and right master loading doors **130, 140** are depicted, it will be seen that the top bars **136, 146** and the bottom bars **138, 148** of the master loading doors **130** are slotted at opposite ends in the manner that the slots **103, 105** are provided in opposite end regions of the extrusions **137, 147** (as described just above) to receive the bar-like formations **102, 104** of the uprights of the doors **130, 140**. Likewise, it will be seen that an upper zone cross-bar **185** and a lower zone cross bar **186** also are slotted at opposite ends in the manner that the slots **103, 105** are provided in opposite end regions of the extrusions **137, 147** (as described just above) to receive the bar-like formations **102, 104** of the uprights of the doors **130, 140**.

[0141] Referring variously to **FIGS. 1-9, 26** and **80**, the left master loading doors **130, 1130, 2130, 3130** and the right master loading doors **140, 1140, 2140, 3140** are provided with differing arrays of the upper and lower zone cross-bars **185, 186**. Referring to **FIGS. 40-43** where cross-sections of the top bars **136, 146**, the upper zone bars **185**, the lower zone bars **186**, and the bottom bars **138, 148** are shown, it will be seen that each of the bars **136, 138, 146, 148, 185, 186** defines one of the downwardly opening recesses **107** into which threaded fasteners (such as the threaded fasteners

127 shown in FIG. 20) can be threaded (after passing through upright holes such as the holes 108 shown in FIG. 39) to secure these bars to associated ones of the uprights 132, 142, 134, 144.

[0142] Other features shared by the bar cross-sections depicted in FIGS. 40-43 include rearwardly-facing undercut grooves 191 that are configured to receive elongate lengths of resilient weatherstrip material of any of a wide variety of commercially available types (see, for example, the weatherstrips 190 shown in FIGS. 44-47); and, concave recesses 192 provided in downwardly facing surfaces 193 of forward portions of the bars 136, 138, 146, 148, 185, 186 that help to prevent moisture from passing rearwardly along the downwardly facing surfaces 193 from front surfaces 201 that are exposed to rain, snow, sleet and other forms of moisture inasmuch as the front surfaces 201 constitute elements of the fronts of the cluster box units 100, 1100, 2100, 3100.

[0143] Referring to FIGS. 10-12, the extrusions 137, 147 that extend centrally across mid portions of the left and right master loading doors 130, 140 also have downwardly facing surfaces 193 that are provided with concave recesses 192 to deter the rearward passage of moisture along the downwardly facing surfaces 193 of the extrusions 137, 147. As also will be noted in FIGS. 10-12, the extrusions 137, 147 are provided with rearwardly facing undercut grooves 191 that, like the rearwardly facing undercut grooves 191 of the bars depicted in FIGS. 40-43, may provide mounting locations for lengths of weatherstripping such as the weatherstrip material 190 depicted in FIGS. 44-47.

[0144] A feature unique to the lower zone bar 186, as seen in FIGS. 42, 46 and 47 is a rearwardly projecting formation 195 configured to extend into underlying relationship with front portions of one of the many shelves 113 that define the "floors" of the various delivered mail and outgoing mail compartments 131, 141, 145 (see FIGS. 9 and 80 wherein several of the shelves 113 are visible). The projecting formation 195 of a lower zone bar 186 is moved into underlying relationship with the front region of one of the shelves 113 when the associated master loading door (that carries the lower zone bar 186) is pivoted to its closed position.

[0145] When the projecting formation 195 of one of the lower zone bars 186 underlies a front of one of the compartment-floor-defining shelves 113, the engagement of the projecting formation 195 with portions of the front end region of the shelf 113 (or with a reinforcing bar that may be provided to stiffen the shelf front, such as the reinforcing bar 194 depicted in FIGS. 46 and 47) will help to maintain alignment of the bar 186 and the associated shelf 113, and may also help to maintain proper registry of components carried by the master loading doors with components carried by the cabinet structures of the cluster box units 100, 1100, 2100, 3100.

[0146] Engagement of any of a variety of rearwardly extending formations of the master loading doors 130, 140, 1130, 1140, 2130, 2140, 3130, 3140 with shelf front portions (for example as has just been described) also can be utilized to resist attempts to gain unauthorized access to one or more of the delivered mail or outgoing mail compartments of the CBUs 100, 1100, 2100, 3100 by forcing portions of one or more of the shelves 113 upwardly or downwardly—for

example, attempts that sometimes are made by would-be thieves who try to pry upwardly one of the shelves 113 that overlies one of the delivered parcel compartments 133, 143 (depicted in FIGS. 9 and 80) in an effort to access one or more of the delivered mail compartments 131, 141.

[0147] One reason why forceful attempts sometimes are made to access the contents of delivered mail compartments by working through one of the delivered parcel compartments is that the doors to the delivered parcel compartments frequently are intentionally left "unlocked," and therefore can be opened at will—which gives would-be intruders access to lower regions of the interior of the cluster box units 100, 1100, 2100, 3100. To prevent such intrusions from succeeding, the shelves 113 that overlie the delivered parcel compartments 133, 143 of the cluster box unit 100 (and corresponding shelves of the cluster box units 1100, 2100, 3100 that overlie the delivered parcel compartments of the cluster box units 1100, 2100, 3100) preferably are securely connected to the side and rear walls 701, 702 of the cabinet structures 700 (see FIG. 80) as by rivets, by welding or other suitable fastening techniques that are not easily broken or disconnected.

[0148] In preferred practice, all of the shelves 113 (including such ones of the shelves 113 as may be permanently fastened to the side and rear walls 701, 702 of the cabinet structures 700 as by riveting, welding or other fastening techniques), and a pair of top-most shelves 13 (FIG. 81) that overlie the uppermost delivered mail compartments 131, 141 are connected to the side and rear walls 701, 702 of the cabinet structures 700 by tab-like clips 710, best seen in FIGS. 80 and 81. The tab-like clips 710 are formed from the material of the side and back walls 701, 702 of the cabinet structures 700—material that is displaced when openings 14 (FIG. 81) are stamped through the side and back walls 701, 702 of the cabinet structures 700. The tab-like clips 710 project upwardly at locations spaced short distances inwardly from the side and back walls 701, 702—short distances that substantially equal the thicknesses of the material that defines the downwardly turned flanges 15 of the shelves 13, 113.

[0149] Referring to FIG. 81, located on opposite sides of each of the generally rectangular openings 14 are generally rectangular openings 16 that are smaller in size than the openings 14. To assist in holding the shelves 13, 113 in proper positions where the downwardly-turned flanges 15 are gripped and supported by the tab-like clips 710, convex projections 17 are formed on the flanges 15—projections that are configured to snap into the openings 16 when the shelf flanges 15 are properly engaged by the tab-like clips 710. The projections 17 can take any of a variety of configurations that are capable of snapping into and being retained within the openings 16 in a manner that will keep the shelves 13, 113 in place in the cabinet structures 700—configurations that render it difficult to lift the shelves 13, 113 out of engagement with the tab-like clips 710.

[0150] Referring to FIGS. 44-47 wherein front portions of one of the shelves 13, 113 are shown, it will be seen that the shelves 13, 113 have downwardly turned front flanges 73 that are reversely bent and turned back upwardly so that each of the flanges 73 has an associated upwardly extending reach of material 74 that is joined to the downwardly turned flange 73 by a smoothly rounded bottom formation 75 that permits

a postal patron to grasp his or her deliveries from compartments located beneath the shelves **13**, **113** without being scratched by sharp edges or burrs of the downwardly turned front flanges **73** of the shelves thereabove.

[0151] If a selected one of the shelves **13**, **113** is provided with a reinforcing bar such as the reinforcing bar **194** depicted in **FIGS. 46 and 47**, the reinforcing bar **194** will help to hold the shelf **13**, **113** in place both by giving the shelf additional strength to support a heavy load of compartment contents, and by reinforcing the shelf **13**, **113** against being pried upwardly. A forwardly projecting portion **76** of the reinforcing bar **194** extends above the upwardly turned reach of material **74** toward a position of engagement with the backside of the downwardly turned flange **73**, by which arrangement the reinforcing bar **194** is connected to the shelf front to resist upward prying of the shelf front.

[0152] The reinforcing bar **194** is supported by connecting its opposite end regions to side walls **701** of cabinet structures **700**, which are best seen in **FIG. 80**. To assist in connecting opposite end regions of the reinforcing bar **194** to the side walls **701**, the extrusion that forms the reinforcing bar **194** has a groove-like recess **77** that runs the full length of the reinforcing bar **194**. The recess **77** has the same configuration as the groove-like recesses **107** provided in the extrusion-formed bars **136**, **138**, **146**, **148**, **185**, **186** depicted in **FIGS. 40-43**—which is to say that the groove-like recess **77** has a rounded inward portion into which fasteners (preferably like the threaded fasteners **127** depicted in **FIG. 20**) can be threaded after passing through holes (not shown) formed through the cabinet structure side walls **701**. When such fasteners are tightened in place, opposite end regions of the reinforcing bar **194** are securely connected to the associated cabinet structure **700** so the bar **194** can perform its intended function of supporting and rigidifying the front region of its associated shelf **13**, **113**.

[0153] Referring to **FIGS. 80**, **82** and **85**, the cabinet structures **700** are substantially identical, one with the other, and are held in spaced, side-by-side relationship two or more identically configured rear connector brackets **820** (see **FIG. 85**), one of which is shown more clearly in **FIG. 83**, and by an upstanding extrusion **830** that has a substantially uniform cross-section along its length, a segment of which is depicted in **FIG. 84**. The full length of the extrusion **830** can be seen in **FIG. 9**. Segments of the extrusion **830** also are depicted in **FIGS. 87 and 88**.

[0154] Referring to **FIG. 83**, each of the rear connector brackets **820** has a pair of end regions that define substantially flat walls **821** that extend in one common plane, a central region that provides another substantially flat wall **823** that extends in another plane that parallels the first common plane of the flat walls **821**, and a pair of transversely extending walls **825** that couple opposite ends of the flat wall **823** to the flat walls **821**. As is best seen in **FIG. 85**, the connector brackets **820** are installed at vertically spaced locations where the flat walls **821** overlap and are rigidly connected to the rear walls **702** of the cabinet structures **700** (best seen in **FIG. 82**), and with the transversely extending walls **825** connected to rear portions of the side walls **701** of the cabinet structures.

[0155] Referring to **FIG. 84**, the extrusion **730** is of generally C-shaped cross-section, and includes right and left legs **832**, **834** connected by a front wall **835**. At locations

spaced a short distance behind the front wall **835**, a pair of opposed projections **836** extend toward each other. Defined between the projections **836** and the front wall **835** is a space that is utilized to slidably house a vertically extending, vertically movable, bar-like slide, portions of which are indicated by the numeral **840** in **FIG. 87**.

[0156] Referring to **FIG. 87**, several openings, indicated by numerals **842**, **843** and **844**, are formed through the front wall **835** of the extrusion **830**—openings that permit portions of the bar-like slide **840** to be seen. Metal wear plates **850** are provided along bottom ends of the openings **842**, **843** and are held in place by rivets **845** or other suitable fastener or fastening means. An operating handle **860**, shown in **FIGS. 86-89**, has a front wall **861** that is connected by fasteners (not shown, that extends through the opening **844**) to the slide **840** to provide a rightwardly extending finger-engageable handle formation **865** that can be grasped to manually raise the slide **840** for the purpose of causing the slide-defined openings **852**, **853** (which openings are at least as tall as the openings **842**, **843** that are formed through the front wall **835** of the extrusion **830**) to more properly align with the openings **842**, **843** so as to permit arrowhead latch formations **900** carried by the master loading doors **130**, **140** (see **FIGS. 9 and 86**) to pass therethrough.

[0157] When the enlarged heads **910** of the arrowhead latch formations **900** have passed through the extrusion-defined openings **842**, **843** and through the slide-defined openings **852**, **853**, the slide **840** drops back down (under the influence of the force of gravity) to a position where the slide-defined openings **852**, **853** do not align sufficiently with the extrusion-defined openings **852**, **853** to enable the enlarged heads **910** to move back out through the openings **852**, **853**. By this arrangement, the left and right master loading doors **130**, **140** are latched closed.

[0158] In operation, to unlatch and open the master loading doors **130**, **140**, one must reach through an opening of the right master loading door **140** (namely the opening that normally is closed by the door-within-a-door element **240** that provides access to the outgoing mail compartment **145** depicted in **FIG. 9**) to grasp and raise the rightwardly projecting handle **865** to raise the slide **840** to a position wherein the extrusion-carried openings **842**, **843** and the slide-carried openings **852**, **853** align sufficiently to permit the enlarged heads **910** of the arrowhead latching formations **900** to pass back through the openings **842**, **843**, **852**, **853** as the master loading doors **130**, **140** pivot open about the axes **51**, **52** (see **FIG. 24**)

[0159] Furthermore, to close and latch in closed position the master loading doors **130**, **140**, the left master loading door **130** is pivoted closed slightly ahead of the right master loading door **140** so that the centrally located uprights **134**, **144** of the master loading doors **130**, **140** will bring their hook-shaped formations **175**, **177** into proper interengaging relationship, as depicted in **FIG. 23**. As the doors **130**, **140** closely approach their fully closed positions, the arrowhead latching formations **900** pass through the openings **842**, **843** of the central extrusion **730** (see **FIG. 87**) and into the openings **852**, **853** of the slide **840**. As tapered upwardly and rearwardly facing surfaces of the enlarged heads **910** of the latching formations **900** engage the material of the slide **840** located at the upper ends of the slide-defined openings **852**, **853**, continued closing movement of the doors **130**, **140**

causes the slide **840** to raise sufficiently into alignment with the extrusion-defined openings **842**, **843** to permit the enlarged heads **910** to pass therethrough. Once the enlarged heads **910** have passed through the slide-defined openings **852**, **853** during closing movement of the doors **130**, **140**, the slide **840** drops down (under the influence of the force of gravity) so as to block reverse movement of the enlarged heads **910**, thereby latching the master loading doors **130**, **140** in their closed positions.

[0160] Moreover, to lock the master loading doors **130**, **140** in their closed position, the door **240** of the outgoing mail compartment **145** must be locked. The locking system for securing the outgoing mail compartment door **240** in its closed position includes a centrally located strike **950** mounted on the right side of the upstanding central extrusion **830** near the rightwardly extending portion **865** of the operating handle **860** (see FIG. 9), and a high security USPS lock **500** (see FIGS. 9, 67, 71, 72) installed on the back side of the outgoing mail compartment door **240** at a location just behind a bracket **960** that has an upper flange **966** which overlies the body **505** of the lock **500**, a lower flange **968** that underlies the body **505** of the lock **500**, and an end portion **962** spaced inwardly from the body **505** of the lock **500**.

[0161] Referring to FIGS. 71 and 72 where the strike **950** is shown most clearly, it will be seen that, as the outgoing mail compartment door **240** is pivoted closed (a partially open position of the door **240** is shown in FIG. 71, followed by FIG. 72 which shows a closed, locked position of the door **240**), a forwardly-projecting end region **952** of the strike **950** is received between the body **505** of the lock **500** and the end portion **962** of the bracket **960**. When the outgoing mail compartment door **240** is closed so that the forward end region **952** of the strike **950** is positioned as just described, an appropriately configured key (not shown) can be turned in the lock **500** to extend the bolt **510** of the lock through aligned openings **954**, **964** of the forward end region **952** of the strike **950** and the end region **962** of the bracket **960** to securely lock the door **240** of the outgoing mail compartment **145** closed.

[0162] When the outgoing mail compartment door **240** is locked closed in the manner just described, the right master loading door **140** also is locked closed (i.e., the door **140** cannot be opened when the door **240** is locked in closed position against the framework **180** (FIG. 25) of the right master loading door); and, when the right master loading door **140** is locked closed, the left master loading door **130** also is locked closed (i.e., the left master loading door **130** cannot be opened when the upright **144** of the right master loading door **140** which overlies and blocks opening movement of the right upright **134** of the left master loading door **130**, which blocked movement is depicted in FIG. 23 where the right door formation **170** overlies the left door formation **175**).

[0163] The approach of latching closed the master loading doors of a cluster box unit by utilizing arrowhead latch formations **900** that pass through aligned openings of a slide mechanism and that are retained when the slide translates to prevent the arrowhead formations from passing back through the slide is known, as is evidenced by U.S. Pat. No. 5,794,844 issued Aug. 18, 1998, assigned to a subsidiary of the assignee of the present application. However, differences exist between the latching system of the present invention and the latching system disclosed in U.S. Pat. No. 5,794,844.

[0164] Referring to FIG. 87, one of several notable improvements and/or structural distinctions (offered by components of the latching system that releasably retains the master loading doors **130**, **140** closed—features not found in the latching system of U.S. Pat. No. 5,794,844) is the provision of easily replaced wear plates **850** (preferably formed from steel, most preferably stainless steel) that are fastened by removable fasteners such as rivets **845** to central portions of the vertically extending central extrusion **830** (preferably formed from aluminum). The wear plates **850** underlie the extrusion-defined openings **842**, **843** to provide upper edges that often will be engaged by bottom surfaces of the arrowhead latch formations **900** when the arrowhead latch formations move back and forth through the openings **842**, **843** during opening and closing of the master loading doors **130**, **140**.

[0165] The hard, wear resistant upper surfaces of the wear plates **850** are not worn away (by bottom surfaces of the steel arrowhead formations **900** rubbing thereacross as the master loading doors **130**, **140** open and close) nearly as quickly as would be the much softer material of the extrusion **830** (aluminum preferably is used to form the extrusion **830**, hence aluminum is the material that defines the openings **842**, **843**). If the wear plates **850** deteriorate (due, for example, to repetitive engagement day-after-day as bottom surfaces of the arrowhead latch formations **900** rub across upwardly facing surfaces of the wear plates **850**), the wear plates **850** can be quickly and easily replaced by drilling out or otherwise removing rivets **845** or other fasteners that hold the wear plates **850** in place on the extrusion **830**, and by installing new wear plates **850** on the extrusion **830** by utilizing new rivets **845** or other suitable fasteners.

[0166] Another of the several improvements and/or structural distinctions offered by latching system components of the cluster box units **100**, **1100**, **2100**, **3100** (in comparison with latching system features disclosed in U.S. Pat. No. 5,794,844) is the smoothly configured, well positioned operating member **860** and its rightwardly extending handle formation **865** that can be located easily when one reaches through the opening of the right master loading door **140** that normally is closed by the outgoing mail compartment door **240**. The rightwardly extending handle formation **865** is located and configured so that it can easily be found when one inserts his or her hand through the door opening, but is located and configured so as to not obstruct the door opening should the USPS delivery person desire to remove mail through the door opening—mail that has accumulated in the outgoing mail compartment **145**.

[0167] Still another feature is the location and configuration of the rightwardly extending handle formation **865** is that, when the right master loading door **140** and the outgoing mail compartment door **240** both are closed, the handle formation **865** projects beneath the upper flange **866** (seen in FIGS. 67-72) in a manner that enables the upper flange **866** of the bracket **860** to block the path of upward movement normally followed by the handle formation **865** when the handle formation is raised to elevate the slide **840** and release the arrowhead formations **900** from being retained in the openings **842**, **843**, **852**, **853**. By blocking the handle formation **865** from being raised, the overlying upper flange **866** of the bracket **860** effectively prevents the master

loading doors **130, 140** from being unlatched at times when the outgoing mail compartment door **240** is closed and locked.

[0168] The delivered mail compartment doors **220** are normally kept closed and locked. Cam locks **920** (FIGS. **1, 2** and **48**) that are mounted on each of the mail compartment doors **220** are operated by keys (not shown) which are maintained in the custody of postal patrons to whom the delivered mail compartments are assigned. The cam locks **920** (FIGS. **1, 2** and **48**) may take the form of conventional, commercially available cam lock assemblies intended for use in turning cams between latched and unlatched positions—which typically involves about one-quarter, one-third or one-fifth of a revolution of turning movement. While conventional, relatively small, relatively thin cams of the type normally provided with cam lock assemblies by the manufacturers of cam lock assemblies may be used to engage suitably configured strike formations to hold the mail compartment doors **220** closed, in preferred practice, heavier-duty cams (that are thicker and larger in size than the relatively thin, relatively small cams normally provided with commercially available cam lock assemblies) are employed, such as the cam **922** depicted in FIGS. **54-57**; or such as the cam **972** depicted in FIGS. **61** and **63-65**.

[0169] Referring to FIGS. **54-57**, the cam **922** preferably is formed from steel (most preferably stainless steel) and has a centrally located opening **924** that receives the rear end region of a key-turnable plug **926** (FIGS. **9** and **55-57**) of the cam lock assembly **920** on which the cam **922** is mounted. The cam **922** can be pivoted by the key-turnable plug **926** about an axis **925** (FIGS. **55-57**) of the plug **926** between an unlatched position depicted in FIG. **57** wherein a latching formation **928** of the cam **922** is withdrawn from engagement with a suitably configured strike **930**, and a latched position depicted in FIG. **56** wherein the latching formation **928** engages the strike **930** so as to retain the delivered mail compartment door **220** (on which the cam lock assembly **920** is mounted, as shown in FIGS. **1, 2** and **48**) in a closed, locked position (shown in FIGS. **1-8**).

[0170] While the strike **930** may take any of a wide variety of conventional configurations, and while the latching formation **928** may take any of a wide variety of configurations offered by the cams that typically are provided by the manufacturers of cam lock assemblies, in preferred practice the latching formation **928** is of hook-shaped configuration and is positioned to extend through an elongate slot-like formation **932** of the strike **930** so that, when the cam **922** is in the latched position shown in FIG. **56**, a reversely turned projecting element **934** of the hook-shaped latching formation **928** is positioned close to and in alignment with an opening **938** of the strike **930**. By this arrangement, if the door **220** on which the cam lock assembly **920** is mounted is pried away from the strike **930** at a time when the cam **922** is in its latched position, the projecting element **934** of the latching formation **928** of the cam **922** will be drawn into the opening **938** to securely couple the cam-lock-carrying door **220** to the strike **930** to strongly resist attempts to defeat the action of the cam lock assembly **920** by prying the locked mail compartment door **220** open.

[0171] Cam lock assemblies **920** (FIGS. **1, 2** and **48**) selected for use on the delivered mail compartment doors **220** preferably are of the type that have keys which can be

removed only when the cams they carry are pivoted to their latched positions. Selecting cam lock assemblies that have only one key removal position (i.e., their key-turned plugs must position their cams in latched positions in order for the keys to be removed from their key-turned plugs) ensures that the delivered mail compartment doors **220** cannot be left unlocked when postal patrons remove their keys from the cam locks (unless, of course, a postal patron fails to properly close the door **220** to his or her delivered mail compartment **131, 141** when leaving the vicinity of the cluster box unit **100**—however, this is unlikely inasmuch as the cam **922** will be seen to project from the end of the door **220**, and the door **220** will be seen to project outwardly from the front plane of the collection box unit **100** if the cam **922** is turned to the locked position at a time when the door **220** is improperly closed).

[0172] Cam configurations, strike configurations and other features of the type just described are disclosed in greater detail in the above-referenced Rugged Cam Lock Cases, with still other features disclosed in the non-provisional application Ser. No. 10/879,570 entitled LINKAGE OPERATED CAM LOCK FOR A CLOSURE, filed Jun. 29, 2004, the disclosure of which is incorporated herein by reference.

[0173] Although the delivered mail compartment doors **220** are not normally provided with return springs to assist postal patrons in closing, and in maintaining closed, the doors **220**, return springs can be provided, if desired. One possible approach to providing return springs on compartment doors of cluster box units is illustrated in FIGS. **59** and **60** in conjunction with the delivered parcel compartment doors **230**.

[0174] Turning to FIGS. **59** and **60**, each of the delivered parcel compartment doors **230** is provided with a torsion return spring **990**. The torsion return spring **990** has an upper end region **991** (best seen in FIG. **59**) connected by an overlapping plate portion **993** to the parcel door **230**, and a lower end region **992** that bears against a framework element of the associated master loading door, typically one of the uprights **132, 134, 142, 144**. The torsion springs **990** bias the parcel doors **230** toward their closed positions—a biasing action that is needed inasmuch as the parcel compartment doors **230** normally are not locked, normally are openable at will, and might stand open (if not biased toward their closed positions) so as to admit moisture and unwanted debris into the associated parcel compartments.

[0175] Each of the delivered parcel compartment doors **230, 1230, 2230, 3230** is provided with a dual-lock, dual-key-operated locking system that permits the parcel door to be locked only by a USPS employee; and USPS employees lock a selected parcel compartment only when they insert into the selected parcel compartment a parcel that is too large to be inserted into the delivered mail compartment of the postal patron to whom the parcel is addressed.

[0176] Referring to FIGS. **58, 63** and **64**, the dual-lock locking system installed on each parcel compartment door **230** includes a USPS installed high security lock **500** that can only be operated by a restricted access key kept continuously in the custody of USPS personnel, and a lower security cam lock assembly **570** (a commercially available cam lock) of the type that has a key-turnable plug **571, 4571** (see FIGS. **63-66**) that will permit the key of the cam lock **570** to be removed from the key-turnable plug **571, 4571**

only when the plug **571**, **4571** is rotated to one particular angular orientation—namely a “door locked” orientation wherein a cam **572** or cams **4572** that is/are operated by the cam lock **570** is/are pivoted into engagement with a strike formation **930** (see **FIGS. 65, 66**) so as to lock the associated parcel compartment door **230** closed.

[0177] Thus, when a parcel compartment door **230** is closed and locked, the key of the cam lock **570** is removed from the cam lock **570** by the USPS employee who has inserted a parcel into the associated parcel compartment. The USPS employee then inserts the parcel compartment door key into the delivered mail compartment of the postal patron to whom the parcel is addressed, and the postal patron (upon finding the key) utilizes it to retrieve his or her parcel by unlocking and opening the associated parcel compartment door **230**.

[0178] In operation, to lock one of the parcel compartment doors **230**, a USPS employee inserts and turns a first key (namely a restricted access key that is maintained continuously in the custody of USPS personnel—usually the same key that is used by USPS personnel to operate the USPS installed high security lock **500** mounted on the outgoing mail compartment door **240**) to operate the USPS high security lock **500** carried on the parcel compartment door **230**. When the high security lock **500** is operated by a USPS employee, this releases the mechanism of the cam lock **570** so the key of the cam lock **570** can be turned to pivot a cam **572** (**FIG. 61**) from an unlatched position (where the cam **572** is retracted into a guard assembly **595** carried on the back side of the parcel door **230**, as depicted in **FIGS. 60 and 61**; or where the cams **4572** are retracted into a guard assembly **4595**, depicted in **FIG. 62**) to the latched position depicted in **FIGS. 61, 62** to lock the associated parcel compartment door **230**.

[0179] Once the parcel compartment door **230** is locked, the keys of both of the locks **500, 570** are removed. The key to the USPS high security lock **500** is retained by USPS personnel. The key to the lower security cam lock **570** is deposited by USPS personnel in the delivered mail compartment of the postal patron who needs to open the parcel compartment to collect his or her parcel.

[0180] Once the postal patron inserts and turns the key (that he or she finds in his or her delivered mail compartment) in the cam lock **570** of the parcel compartment door **230**, the high security USPS lock **500** prevents the lower security cam lock **570** from re-locking the parcel compartment door **230**, and the key of the lower security cam lock **570** (which has been turned by the postal patron to an unlocked position) is retained in the cam lock **570** until a USPS employee next takes action to relock the parcel compartment door **230** because he or she has delivered a new parcel into the associated parcel compartment **133, 143**. The dual-key, dual-locking system used on the parcel compartment doors **230** is (in the manner just described) put through one cycle of operation after another as new parcels (too big to be inserted into the delivered mail compartments **131, 141** of the postal patrons to whom the parcels are addressed) are, from time to time, delivered to the parcel compartments **133, 143** and retrieved by the postal patrons to whom the parcels are addressed.

[0181] One form of a dual-key, dual-locking system for parcel compartment doors is disclosed in U.S. Pat. No.

4,865,248 issued Sep. 12, 1989, the disclosure of which is incorporated herein by reference. A more preferred form of a dual-key, dual-locking system for use with the parcel compartment doors **230** is disclosed in the referenced non-provisional application Ser. No. 10/879,570 entitled LINKAGE OPERATED CAM LOCK FOR A CLOSURE, filed Jun. 29, 2004, the disclosure of which is incorporated herein by reference.

[0182] Among the types of dual-key, dual-locking system features are linkage operated single-cam locking systems of the type depicted in **FIGS. 61 and 63-65** hereof, and linkage operated plural-cam locking systems of the type depicted in **FIGS. 62 and 66** hereof. To provide a quick overview of these linkage operated cam locking systems, reference is made to **FIGS. 63-65** where a single cam **572** is shown, and to **FIG. 66** wherein plural cams **4572** are shown. The cams **572, 4572** are mounted on door-carried, post-like pedestals **573, 4573** to pivot between latched positions shown in **FIGS. 63, 65 and 66**, and an unlatched position shown in **FIG. 64**. Pivoting of the cams **572, 4572** between the depicted latched and unlatched positions is caused by pivotal movement of operating arms **574, 4574** carried on the key-turned plugs **571, 4571** of associated cam lock assemblies (for example, the cam lock **570** that is depicted in **FIGS. 58 and 63**).

[0183] Referring to **FIGS. 65 and 66**, it will be seen that the cams **572, 4572** (like the cam **928** depicted in **FIGS. 54-57**) have latching portions **928** that, when in the depicted latched positions of the cams **572, 4572**, preferably extend through elongate slot-like receiving formations **932** of the strikes **930**. When in the depicted latched positions shown in **FIGS. 65 and 66**, reversely turned projections **934** of the cams **572, 4572** reside close to and in alignment with openings **938** formed through the strikes **930** so that, if the parcel compartment doors **230** on which the cams **572, 4572** are supported are pried away from the depicted strikes **930**, the projections **934** will be drawn into the openings **938** to aid in securely holding the parcel compartment doors **230** closed.

[0184] The operating arms **574, 4574** pivot between normal positions depicted in **FIGS. 63, 65 and 66**, and an operated position shown in **FIG. 64** to cause links **576, 4576** (that couple the operating arms **574, 4574** to the cams **572, 4572**) to pivot the cam **572** or the link interconnected cams **4572** between their latched positions shown in **FIGS. 63, 65 and 66**, and an unlatched position shown in **FIG. 64**. The operating arms **574, 4574** carry spring members **577, 4577** that interact with the retractable-extensible latch bolts **510** of the associated USPS installed high security locks **500** to control when the operating arms **574, 4574** can pivot from their operated positions (shown typically in **FIG. 64**) to their normal, non-operated positions (shown in **FIGS. 63, 65 and 66**) to pivot the cam **572** or cams **4572** from their unlatched positions (one of which is shown in **FIG. 64**) to their latched positions (shown in **FIGS. 63, 65 and 66**). Structural features that may be utilized in single and/or plural cam locking systems of this general type are shown in **FIGS. 65-66** accordingly.

[0185] The protective outer enclosure **110** that houses, surrounds and encloses the various interior components of the cluster box unit **100** has several features that merit mention. Referring to **FIGS. 73-75**, the enclosure **110** has

opposed side walls **901**, a rear wall **902** and a top wall **903** that cooperate with a bottom assembly **905** to define a forwardly-opening compartment **906** into which most of the interior components of the cluster box unit **100** are inserted after the interior components are assembled. The side and rear walls **901**, **902** are integrally formed, as by bending a sheet of metal (preferably aluminum or stainless steel) to provide right-angle corners that connect the rear wall **902** to tie side walls **901**.

[0186] The top wall **903** is formed from a sheet of metal (preferably aluminum or stainless steel) that is bent to provide depending side and rear flanges **911**, **912** (see FIGS. **73-75** and **78**) that overlie upper portions of the side and rear walls **901**, **902**, respectively; and to provide a downwardly extending, reversely turned front portion **913** (see FIG. **76**) having an upwardly concave formation **914** that functions in the manner of the concave recesses **192** of the cross-bars **136**, **138**, **146**, **148**, **185**, **186** (see FIGS. **40-43**) to prevent moisture from traveling rearwardly along downwardly facing surfaces, such as the downwardly facing surface **915** shown in FIG. **76**.

[0187] The side walls **901** are provided with vertically extending members **918** (see FIGS. **73**, **75** and **77**) that are configured to be engaged by edge portions **919** of the upstanding extrusions **152**, **162** (see FIGS. **18** and **19**) of the rectangular frame **160** (see FIG. **15**) when the frame **160** (with the master loading doors **130**, **140** installed thereon) is secured by threaded fasteners (not shown) to the enclosure **110** after other internal components of the cluster box unit **100** have been inserted into the interior of the enclosure **110**. All fasteners used to fasten the interior components of the cluster box unit **100** in place within the enclosure **110** are accessible only when the master loading doors **130**, **140** are unlocked and open—an arrangement that prevents unauthorized access by those who would utilize tools to remove fasteners that hold together components of the cluster box unit **100** if such fasteners were accessible from the exterior of the unit **100**.

[0188] Referring to FIG. **79**, the bottom assembly **905** includes a bottom wall member **906** having downwardly turned side and rear flanges **907**, **908** that are fastened to the side and rear walls **901**, **902**, and a downwardly turned front flange **909** (see FIG. **75**) that defines a forwardly facing surface at the bottom of the enclosure **110**. Referring to FIGS. **73** and **79**, a pair of floor reinforcing members **919** extend forwardly-rearwardly between the downwardly turned rear and front flanges **908**, **909** to define mounting holes **916** (FIG. **79**) that are accessible through bottom wall openings **917** (FIG. **73**) when bolts (not shown) are to be installed that connect the enclosure **110** to the pedestal support **120** (FIG. **1**).

[0189] Referring to FIGS. **40-43**, the bars **136**, **138**, **146**, **148**, **185**, **186** that are utilized in the frameworks of all of the master loading doors **130**, **1130**, **2130**, **3130**, **140**, **1140**, **2140**, **3140** all have forwardly-facing surfaces **200**. Referring to FIG. **25** (wherein the framework **180** of one of the master loading doors **130**, **140**, **1130**, **1140**, **2130**, **2140**, **3130**, **3140** is depicted), the forwardly-facing surfaces **200** align with forwardly facing surfaces **202**, **204** of the bar-like formations **102**, **104** of the left and right uprights of the associated master loading door. The alignment of the surfaces **200**, **202**, **204** (i.e., the fact that the surfaces **200**, **202**,

204) extend in a common plane) provides a perimetrically extending backstop against which the doors **220**, **230**, **240** that individually serve the various delivered mail, delivered parcel and outgoing mail compartments (such as the compartments **131**, **133**, **141**, **143**, **145** depicted in FIG. **9**) of the cluster box unit mail delivery receptacles **100**, **1100**, **2100**, **3100**.

[0190] Referring still to FIG. **25**, to pivotally connect the doors **220**, **230**, **240** to the framework **180**, an elongate hinge rod **250** is provided that extends through aligned holes **251** formed through right end regions of the various horizontally extending bars **146**, **148**, **185**, **186**, and through a right end region of the extrusion **147**. The hinge rod **250** has threaded end regions **252** onto which lock nuts **253** may be threaded. The hinge rod **250** is held in place (after being inserted through the aligned holes **251** of the framework **180** and through hinge-rod-receiving passages **255** provided in right end regions of the doors **220**, **230**, **240**) by installing the lock nuts **253** on the threaded end regions **252** and tightening the nuts **253** to draw the nuts into cylindrical recesses defined by the top and bottom bars **146**, **148** of the framework **180**, such as the cylindrical recess **256** provided in the top bar **146** as depicted in FIG. **26**.

[0191] In practice, the doors **220**, **230**, **240** are formed as extrusions that have uniform cross-sections that extend from top to bottom of each of the doors **220**, **230**, **240**. However, the fact that each of the doors **220**, **230**, **240** preferably is formed as an extrusion that, when extruded, features a uniform cross-section from top to bottom should not be misinterpreted to mean that the doors **220**, **230**, **240** all have the same cross-sections; or that the extrusion-formed uniform cross-sections of the doors **220**, **230**, **240** remain unmodified after the extrusions that forms the various doors **220**, **230**, **240** are cut into appropriate lengths that correspond to the top-to-bottom dimensions of the doors **220**, **230**, **240**.

[0192] Stated in another way, blanks that are used to form the doors **220**, **230**, **240** may be cut from extrusions that all have the same cross-section, or from extrusions that feature a variety of different cross-sections. After door blanks are extrusion-formed and cut to appropriate lengths, the blanks may be stamped or machined or otherwise reconfigured so that, when in final form and ready for installation, they do not necessarily have cross-sections that are uniform along the top-to-bottom lengths of the doors **220**, **230**, **240**, **1220**, **1230**, **1240**, **2220**, **2230**, **2240**, **3220**, **3230**, **3240** of the CBUs **100**, **1100**, **2100**, **3100**.

[0193] Referring to FIGS. **48-52** wherein one preferred form of delivered mail compartment door is indicated generally by the numeral **220**, it will be seen that the door **220** has an enlarged, rounded right end region **221**, an enlarged left end region **222**, and a central reach **223** that is substantially flat and of substantially uniform thickness except 1) where a generally rectangular indentation **224** has been formed at a central location to provide a forwardly facing recess **225** that can receive a compartment identification label (not shown), and 2) at a location near the left end region **222** where a rearwardly-opening groove **226** has been provided to diminish the thickness of the door in the vicinity where the cam lock **920** is mounted in an opening (not shown) formed through the door **220**. In FIGS. **48-52**, only front portions of the cam lock **920** are depicted inasmuch as

the nature of the conventional, commercially available cam lock **920** that ordinarily is mounted on the mail compartment doors **920** has been disclosed earlier herein.

[0194] Referring to FIGS. 33-38 and 58-60, an alternate form of door cross-section (that is thicker than the delivered mail compartment doors **220**) is used to form the delivered parcel compartment doors **230**. The doors **230** have a cross-section that is of uniform thickness except 1) where a generally rectangular indentation **234** (FIG. 58) has been formed at a central location to provide a forwardly facing recess **235** that can receive a compartment identification label (not shown), and 2) at a location near the right end region where a region **232** of diminished cross-section extends rightwardly, terminating in a relatively thin hook-like formation **233** that extends the full height of the right end region of the door **230**. The hook-shaped formation **233** (FIG. 59) preferably is configured so that, from the front side of the doors **230**, the doors **230** have an appearance that is almost completely identical to the appearances of the right end regions **221** of the delivered mail compartment doors **220**.

[0195] On the back side of the door **230** (in the region **232** of diminished cross-section), a vertically extending sheet of metal **235** (best seen in FIGS. 35, 38 and 60) is mounted that extends nearly, but not completely, the full height of the right end region of the door **230**. The sheet of metal **235** has a curved formation **236** (FIG. 60) that encircles the hinge rod **250** (FIG. 25) that pivotally mounts the doors **220**, **230**, **240** on the frameworks of the left and right master loading doors **130**, **140** (and on the other master loading doors **1130**, **1140**, **2130**, **2140**, **3130**, **3140**). As is best seen in FIG. 60, a portion **237** of the curved formation **236** may be cut away to provide room for the torsion return spring **990** that biases the parcel doors **230** closed, and a portion **993** of the metal sheet **235** may be configured to receive a leg **991** of the return spring **990**.

[0196] Referring to FIGS. 67-72, the same thick cross-section used to form the parcel doors **230** also is preferably used to form the outgoing mail compartment door **240**—and a curved metal sheet **235** of the type employed on the doors **230** is used to define a hinge rod passage **255** for mounting the door **240** on the hinge rod **250**.

[0197] As will be apparent from the foregoing description taken together with the accompanying drawings, the cluster box units **100**, **1100**, **2100**, **3100** preferably incorporate a wide variety of improvement features that enhance security and attack resistance while utilizing components that can be assembled quickly and easily, and that can be serviced as needed in order to keep the units **100**, **1100**, **2100**, **3100** functioning properly for service lives that last many years. Included among the many features disclosed herein are protective enclosure improvements, internal cabinetry improvements, door, hinge and locking system improvements, and a host of other features that are not found in present day cluster box units—features that are intended to provide units that function smoothly throughout lengthy service lives, that resist corrosion, offer good appearances, and that shield mail and parcels from inclement weather and from unauthorized access or attack.

[0198] The cluster box units **100**, **1100**, **2100**, **3100** have outgoing mail compartment doors that are heavily constructed and rigidly reinforced, with the locks carried

thereon protectively shielded, and with the extensible bolts of these locks being engaged by brackets that not only lock the outgoing mail compartment doors but also the master loading doors of the cluster box units.

[0199] Master loading doors are provided with hinges that extend the full height of the doors—hinges that are defined by pivotally interfitting elements of extrusions that very sturdily mount the master loading doors, that prevent prying or bending the doors in the vicinities of their hinges. The interfitting elements of the hinge extrusions also permit the doors to be installed on their surrounding door frames quickly and easily, and permit one or both of the master loading doors to be quickly and easily removed for service or replacement when necessary.

[0200] Although the invention has been described in its preferred form with a certain degree of particularity, it is understood that the present disclosure of the preferred form has been made only by way of example, and that numerous changes in the details of construction and the combination and arrangement of parts may be resorted to without departing from the spirit and scope of the invention. It is intended to protect whatever features of patentable novelty exist in the invention disclosed.

[0201] Other embodiments of the invention will be apparent to those skilled in the art from consideration of the specification and practice of the invention disclosed herein. It is intended that the specification and examples be considered as exemplary only, with a true scope and spirit of the invention being indicated by the following claims.

What is claimed is:

1. A cluster box mail delivery unit comprising:

an enclosure comprising two sidewalls, a top wall, a bottom wall, a front face, and a back face;

at least two door assemblies on the front face of the enclosure, wherein each door assembly comprises a first inner edge and a first outer edge;

at least one compartment door within each door assembly configured to pivot relative to the door assembly; and

at least one fastening member formed along the first inner edge of each door assembly for securing the at least two door assemblies in a closed position,

wherein each door assembly pivots relative to the enclosure along the first outer edge of each door assembly,

each fastening member further comprising an upright portion, an extending portion, and a hook portion,

each upright portion further comprising a second inner edge and a second outer edge, and

each hook portion protruding outward from the second inner edge of the upright portion and engaging with an opposing hook portion, forming a gap between at least one second inner edge of the upright portion and the engaged hook portions.

2. The cluster box mail delivery unit of claim 1, wherein each hook portion comprises at least one rearwardly turned hook portion and at least one forwardly turned hook portion.

3. The cluster box mail delivery unit of claim 1, wherein the second outer edge of the upright portion comprises a bar portion for anchoring the fastening member into the door assembly.

4. The cluster box mail delivery unit of claim 1, wherein the extending portion comprises a box-shaped cross-section.

5. The cluster box unit of claim 1, wherein the hook portions are configured to rigidly interlock as the gap is widened between the at least one second inner edge of the upright portion.

6. A fastening apparatus for securing at least two door assemblies of a cluster box mail delivery unit comprising:

- an upright portion;
- an extending portion; and
- a hook portion;

wherein the upright portion comprises an inner edge and an outer edge; and

wherein each hook portion protrudes outward from the inner edge of the upright portion and engages with an opposing hook portion, forming a gap between at least one inner edge of the upright portion and the engaged hook portions.

7. The fastening apparatus of claim 6, wherein each hook portion comprises at least one rearwardly turned hook portion and at least one forwardly turned hook portion.

8. The fastening apparatus of claim 6, wherein the outer edge of the upright portion comprises a bar portion for anchoring the fastening member into the door assembly.

9. The fastening apparatus of claim 6, wherein the extending portion comprises a box-shaped cross-section.

10. The fastening device of claim 6, wherein the hook portions are configured to rigidly interlock as the gap is widened between the at least one second inner edge of the upright portion.

11. A door with a rugged door hinge for pivotally mounting the door in a cluster box mail delivery unit, comprising:

- an interfitting upright extrusion mounted on a door frame, wherein the extrusion has a complexly curved groove;
- a curved formation located on the door upright and extending into said complexly curved groove of the frame extrusion, and

an elongated hinge rod extending through the full longitudinal length of the door, wherein the hinge further extends over the full longitudinal length of the door.

12. The door of claim 11, wherein the elongated hinge rod extends through an end region of the curved formation of the door.

13. The door of claim 12, including end regions having hinge-rod-receiving passages therein, the hinge rod being inserted through the aligned holes of the door frame extrusion and through hinge-rod-receiving passages.

14. The combination of claim 13, wherein the cross section of the door frame extrusion extends the full height along the pivot side of the door.

15. The combination of claim 14, wherein the curved groove of the door frame extrusion has a complex cross-sectional configuration that receives in an interfitting relationship the curved formation of the door upright extrusion in a manner that permits the door to open and close about a pivotal axis.

16. A master loading door of a cluster box mail delivery unit having a hinge pivotally mounting the door, comprising:

an interfitting upright extrusion on the door frame wherein the upright extrusion has a complexly curved groove;

a curved formation of the door upright and extending into the curved groove of the upright extrusion; and

an elongated hinge rod extending through the full longitudinal height of the door, wherein the hinge further extends over the full longitudinal length of the door.

17. The master loading door of claim 16, wherein the elongated hinge rod extends through an end region of the curved formation of the master loading door.

18. The master loading door of claim 17, including end regions having hinge-rod-receiving passages therein, the hinge rod being inserted through the aligned holes of the door frame extrusion and through the hinge-rod-receiving passage.

19. The master loading door of claim 18, wherein the cross section of the master loading door frame extrusion extends the full longitudinal height along the pivot side of the master loading door.

20. The master loading door of claim 19, wherein the curved groove of the master loading door frame extrusion has a complex cross-sectional configuration that receives in an interfitting relationship the curved formation of the master loading door upright extrusion in a manner that permits the door to open and close about a pivotal axis.

21. The master loading door of claim 20, wherein individual mail box doors on the master loading door are formed as extrusions having uniform cross-sections which extend from top to bottom of each of the individual doors.

* * * * *