

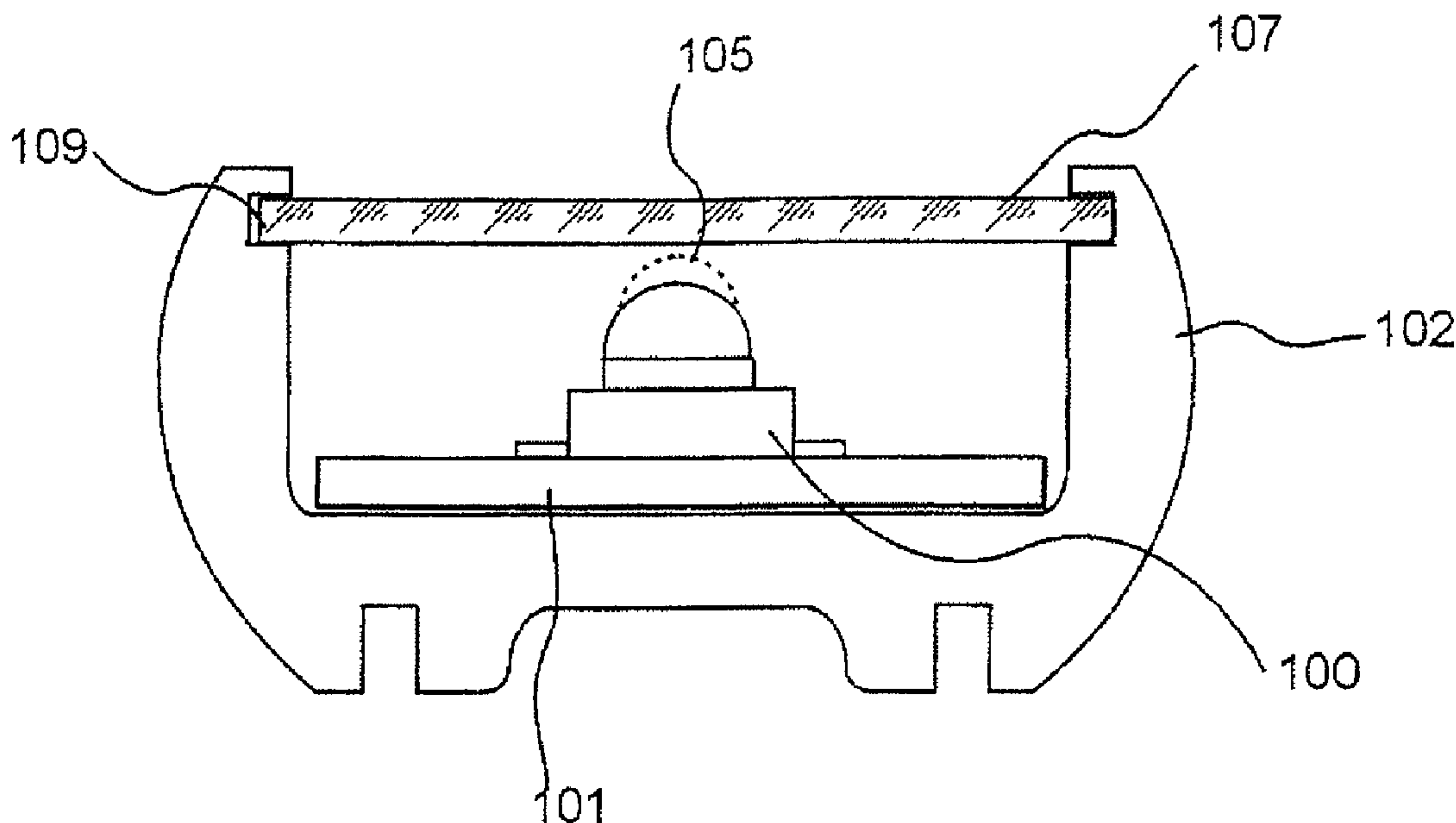

(22) **Date de dépôt/Filing Date:** 2006/08/01
 (41) **Mise à la disp. pub./Open to Public Insp.:** 2007/08/09
 (45) **Date de délivrance/Issue Date:** 2015/11/17
 (30) **Priorité/Priority:** 2006/02/09 (US11/351,074)

(51) **Cl.Int./Int.Cl. H05B 33/00** (2006.01),
H05B 33/08 (2006.01), **F21S 8/10** (2006.01),
F21S 8/00 (2006.01)
 (72) **Inventeur/Inventor:**
 SHAN, XINXIN, CA
 (73) **Propriétaire/Owner:**
 LED SMART INC., CA
 (74) **Agent:** LAMBERT, ANTHONY R.

(54) **Titre : SYSTEME D'ECLAIRAGE A DEL**
 (54) **Title: LED LIGHTING SYSTEM**



(57) **Abrégé/Abstract:**

A light emitting diode lighting device and system that can be used for illuminating the interior and/or exterior of vehicles, aircraft, watercraft, signage or buildings is provided. It includes a voltage feedback constant current power supply circuitry and high power LEDs. The printed circuit assemblies are firmly mounted onto a continuous or semi-continuous mounting channel case that also works as a heat sink. By this means, it not only increases the reliability of the LED lighting tube but also it provides sufficient heat dissipation capability for the heat generated by the LEDs. Since the operating temperature of the LEDs is controlled and stays in cool condition, it dramatically increases the LED's lifetime and efficiency. The end caps of this LED lighting device are fully compatible with existing conventional fluorescent light fixtures and can directly replace those fluorescent lighting tubes in vehicles, mass-transit, watercrafts, aircrafts, signage or buildings with minimal modifications.

ABSTRACT OF THE DISCLOSURE

A light emitting diode lighting device and system that can be used for illuminating the interior and/or exterior of vehicles, aircraft, watercraft, signage or buildings is provided. It includes a voltage feedback constant current power supply circuitry and high power LEDs. The printed circuit assemblies are firmly mounted onto a continuous or semi-continuous mounting channel case that also works as a heat sink. By this means, it not only increases the reliability of the LED lighting tube but also it provides sufficient heat dissipation capability for the heat generated by the LEDs. Since the operating temperature of the LEDs is controlled and stays in cool condition, it dramatically increases the LED's lifetime and efficiency. The end caps of this LED lighting device are fully compatible with existing conventional fluorescent light fixtures and can directly replace those fluorescent lighting tubes in vehicles, mass-transit, watercrafts, aircrafts, signage or buildings with minimal modifications.

LED LIGHTING SYSTEM

BACKGROUND

[0001] The presented LED lighting system relates to a retrofit and direct replacement of conventional fluorescent lighting tubes with light emitting diode (LED) lighting devices for usage in vehicles, including mass-transit vehicles such as buses, trains, subway trains, also for lighting watercrafts, aircrafts, signage, or buildings using LEDs.

[0002] For many years the lighting of interiors of vehicles, aircraft, buildings, signage, and watercraft, and more recently the lighting of exteriors of vehicles, and signage have use the cold cathode lamp; more commonly known as the fluorescent lamp or a fluorescent system. The fluorescent lamp however has limitations on its capabilities and usages. The fluorescent lamp has disadvantages to the consumer. The disadvantages of the fluorescent lamp are the short life, easily broken, low durability, high costs of replacement, high costs of specialty lights, limited color selection, electromagnetic interference (EMI) which may be harmful to other electronic equipment. The manufacturing of fluorescent lamps and debris from replaced lamps have a high environmental risks, as the chemicals inside of a fluorescent lamp are toxic. Also the flicker effect of dying or improperly installed fluorescent lamps may be extremely harmful to individuals with certain medical conditions. The constant inconsistency of fluorescent lighting colors is often a complaint of consumers who have to replace lamps on a regular basis. A fluorescent system cannot be used effectively in extreme low or high ambient temperatures.

[0003] To attempt to avoid difficulties with fluorescent lighting, proposals have been made to use LEDs as replacements for fluorescent lighting, as for example described in United States patent no. 6,860,628 issued March 1, 2005 and United States patent no. 6,583,550 issued June 24, 2003. While these devices do provide some of the advantages of LEDs, there remains a need for lighting systems that can supply sufficient illumination to meet lighting requirements in vehicles, including mass-transit vehicles such as buses, trains, subway trains, also for lighting watercrafts, aircrafts, buildings and signage without excessive heat build up, while reducing the amount of lamps, wiring, ballasts, power consumption and maintenance that fluorescent systems require.

SUMMARY

[0004] There is therefore provided a light emitting diode lighting device and system that can be used for illuminating the interior and/or exterior of vehicles, aircraft, watercraft, signage or buildings is provided. The system may include a voltage feedback constant current power supply circuitry and high power LEDs. The printed circuit assemblies are preferably firmly mounted onto a continuous or semi-continuous mounting channel case that also works as a heat sink. By this means, it not only increases the reliability of the LED lighting tube but also it provides sufficient heat dissipation capability for the heat generated by the LEDs. Since the operating temperature of the LEDs is controlled and stays in cool condition, it dramatically increases the LED's lifetime and efficiency. The end caps and pins of this LED lighting device are fully compatible with existing conventional fluorescent light fixtures and can directly replace those fluorescent lighting tubes in vehicles, mass-transit, watercrafts, aircrafts, signage or buildings with minimal modifications.

[0005] In various embodiments, the LED lighting system described here may have a housing forming a channel and being heat conductive and rigid, with one or both ends of the housing having electrical connectors for connection to a power source. An LED array extends along the housing within the channel, each LED in the LED array having a power rating of greater than 0.5 watt. Onboard current control circuitry for the LED array is carried by the housing, preferably within the channel, and may provide current control for individual sets of LEDs. The current control allows careful control of the forward current passing through the LED array so that it controls the brightness and heat production by the LEDs.

BRIEF DESCRIPTION OF THE DRAWINGS

[0006] There will now be described preferred embodiments of an LED lighting system, with reference to the drawings, by way of illustration only, in which like numerals denote like elements and in which:

[0007] Fig. 1 is a cross cut view from inside of single pin type LED lighting system;

[0008] Fig. 2 is a cross cut view from inside of 'bi-pin'-two pin type LED lighting system;

[0009] Fig. 3 is a cross cut view from inside single or 'bi-pin'- two pin type of LED lighting

system showing permanent, for example, rivet or screw, mounting;

[0010] Fig. 4 is an end view of single pin type of LED lighting system;

[0011] Fig. 5 is an end view of recessed double contact base, two pin type LED lighting system;

[0012] Fig. 6 is an end view of 'bi-pin', two pin type LED Lighting Tube;

[0013] Fig. 7 is a top view of single pin design, one end cross cut, to view interior configuration;

[0014] Fig. 8 is a top view of single pin design, with lens;

[0015] Fig. 9 is a top view of recessed double contact base-two pin design, one end cross cut, to view interior configuration;

[0016] Fig. 10 is a top view of recessed double contact base-two pin design, with lens;

[0017] Fig. 11 is a top view of 'bi-pin'-two pin design, one end cross cut, to view interior configuration;

[0018] Fig. 12 is a top view of 'bi-pin'-two pin design, with lens;

[0019] Fig. 13 is a block diagram of single series of electronics (1.5V ~72V) for onboard current control;

[0020] Fig. 14 is a block diagram of multi series of electronic configuration (1.5V~72V) for onboard current control;

[0021] Fig. 15 is a 3-D view of the LED Lighting tube, without end fittings;

[0022] Fig. 16 is a 3-D side view of the LED Lighting tube, without end fittings;

[0023] Fig. 17 shows an LED lighting system in a mass-transit application, bus shown here for reference purposes, new or retrofit application;

[0024] Fig. 18 shows an LED lighting system in a vehicle application, taxi side view, for taxi advertisement sign;

[0025] Fig. 19 shows an LED lighting system in a vehicle application, taxi top view, for taxi advertisement sign;

[0026] Fig. 20 shows an LED lighting system in a vehicle application, taxi front view, for taxi advertisement sign;

[0027] Fig. 21 shows an LED lighting system in a vehicle application, taxi side view, for taxi 'on-duty' sign;

[0028] Fig. 22 shows an LED lighting system in a vehicle application, taxi top view, for taxi 'on-duty' sign;

[0029] Fig. 23 shows an LED lighting system in a vehicle application, taxi front view, for taxi

'on-duty' sign;

[0030] Fig. 24 shows an LED lighting system in an airplane application, cross cut view of fuselage;

[0031] Fig. 25 shows an LED lighting system in an airplane application, bottom view of fuselage;

[0032] Fig. 26 shows an LED lighting system in a mass-transit application, cross cut view of bus;

[0033] Fig. 27 shows some examples of lenses for the LED lighting system;

[0034] Fig. 28 shows an LED lighting system in a fluorescent lamp, replacement, retrofit, or new installation;

[0035] Fig. 29 is a top view of vehicle application LED lighting system, powered end;

[0036] Fig. 30 is an end view of vehicle application LED lighting system, powered end;

[0037] Fig. 31 is a cross cut view of vehicle application LED lighting system, powered end;

[0038] Fig. 32 is a Top view of vehicle application LED lighting system;

[0039] Fig. 33 is an End view of vehicle application LED lighting system;

[0040] Fig. 34 is a cross cut view of vehicle application of LED lighting system;

[0041] Fig. 35 is a block diagram of onboard current control electronics for a high voltage application, single series (73V~240V);

[0042] Fig. 36 is a block diagram of onboard current control electronics for high voltage application, multiple series (73V~240V); and

[0043] Fig. 37 is a signage application, with a view of replacement of fluorescent lamps in signage

[0044] Fig. 38 is a cross cut view of an LED lighting system with LED arrays facing different directions.

[0045] Fig. 39 is a view of multiple sections of an LED lighting system with LED arrays facing different directions.

DETAILED DESCRIPTION OF PREFERRED EMBODIMENTS

[0046] In this patent document, “comprising” means “including”. In addition, a reference to an element by the indefinite article “a” does not exclude the possibility that more than one of the element is present.

[0047] In Figs. 1-3, 7-12, there is shown an exemplary LED lighting system 10 that includes a plurality of LEDs 100, each LED 100 being supplied power from a circuit board 101 supported by housing 102. Housing 102 forms a channel and is made of a heat conductive and rigid material, such as aluminum or any thermally conductive formable material. In one embodiment, the housing 102 is both heat conductive and rigid and is made of a unitary piece of material. The housing 102 is rigid and extends from end to end of the LED lighting system 10. The heat sink capability may be continuous from end to end or may be semi-continuous. In the case of being semi-continuous, the material providing the heat sink function may have breaks, in which case additional connector material is required to provide the channel with sufficient rigidity so that the lighting system 10 does not collapse or sag under its own weight. The circuitry 20 or 30 provide current control for the LED lighting system 10 and are attached to the housing 102 permanently such as by fasteners 108 (Fig. 3), which may be rivets or screws, so they do not allow for vibration to loosen the connection between the circuit board 101 and the housing 102 over time. The housing 102 does not require adhesive, or thermally conductive substance to connect to the circuit board 101. The housing 102 provides a rigid backbone structure to the LED lighting system 10, and is sufficiently rigid to prevent the LED lighting system 10 to resist or prevent breakage during normal use, or bending, unless the product design requires it. The housing 102 may be provided with a cover 107 secured in a groove 109 that runs along the inside edge of the housing walls. The cover 107 is transparent, translucent and may be formed as a lens.

[0048] At one or both ends of the housing 102 there are provided electrical connectors 103, 105, and 106 for connection of the lighting system 10 to a power source. When LED lighting system 10 is configured as a bulb, rather than as tube, it will typically have connectors only at one end. In the embodiment of Figs. 1, 4, 7 and 8, a single connector 105 of Pin Type 1 is formed in end caps of the housing 102. In the embodiment of Figs. 2, 5, 6, and 9-12 double connectors 106 of

Pin Type 2, either in the bi-pin format (Figs. 6, 11 and 12) or the recessed double contact type (Figs. 5, 9 and 10) are formed in end caps 104 of the housing 102. These connectors 105, 106 are of conventional design. The end caps 104 may be any suitable material such as plastic, Lexan™, polycarbonate, acrylic, ABS, metal such as aluminum, copper, brass, stainless steel, metal alloy, combination of metal and plastic, or fiberglass. The end caps 104 may be manufactured in different shapes and sizes, all able to connect to the circuit boards 101 within the housing 102. The end caps 104 encase the channel, are secured against movement and do not break with vibration. The end caps 104 also secure and prevent movement of the lens 107, 118-127. As with the other components of the lighting system 10, the end caps 104 should be made to withstand high ambient temperatures (up to 125°C+) and low ambient temperatures (as low as -40°C). In the case of use of the LED lighting system 10 as a fluorescent light fixture replacement, the connectors 105, 106 are conventional pins for attached to fluorescent light fixture receptacles. In other embodiments, such as when the LED lighting system 10 is used in a single socket fixture, the connectors 106 may be provided at one end only of the housing 102.

[0049] An LED array formed of LEDs 100 extends along the housing within the channel formed by the housing 102. To provide sufficient power to provide light, particularly in an industrial or commercial environment, each LED 100 in the LED array should have a power rating of greater than 0.5 watt. The circuit boards 101 provide onboard current control circuitry for the LED array. The circuit boards 101 are carried by the housing 102 and are in electrical communication with the electrical connectors 103, 105, 106. The LEDs 100 are preferably organized in groups of LEDs, either in series, or parallel. The LEDs may be surface mounted (SMT) or through hole mounted (TH). The colour of the LEDs can be any available colour such as white, blue, green, red, yellow, amber, or orange.

[0050] Figs. 13 and 14 show circuit diagrams with an example circuit 20 for onboard current control. The circuits of Figs. 13, 14, 35, 36 may all be placed on the circuit board or boards 101. Fig. 13 illustrates a single circuit 20 connected to a conventional power source 208, while Fig. 14 shows multiple circuits 20 in parallel connected to a conventional power source 208. The circuit boards 101 for the circuits 20 may be made of fiberglass based printed circuit board (PCB) or metal based (for example Aluminum) PCB. The circuit boards 101 may be TH type or SMT

type. Preferably, the surface of the circuit boards 101 have a white solder mask and exposed areas of tinned plane so as to efficiently reflect the majority of LED light. The circuit boards 101 may be flexible to accommodate mounting channels and lighting fixtures in different shapes and curves. As shown in Figs. 13 and 14, the LED array is divided into sets 209 of LEDs, with for example five LEDs per set. As shown in Fig. 14, the onboard current control circuitry is formed of multiple circuits 20. Each circuit 20 of the multiple current controllers provides current control for a corresponding set 209 of LEDs in the LED array.

[0051] The onboard current control circuitry 20 is configured to provide constant current to the LEDs 100 of the LED array 209. A polarity protection circuit 201 of conventional design safeguards against the user installing the product in the wrong polarity. Current control is provided by current control circuit 202, also of conventional design. As an example, the current control circuit 202 may be use pulse width modulation (PWM) to control the current supplied to the LEDs. The circuit 202 supplies constant, controlled, current to unit for the entire LED set 209 with information from voltage sensor 203. The voltage sensor 203 receives current information from LEDs 209 and feeds back information to the current control circuitry 202. For example, in the use of PWM, the voltage sensor 203 converts the current of LED array 209 to voltage signal and supplies the voltage signal to the current control circuit 202. The current control circuit 202 senses how much the detected voltage varies from the desired level, and by varying the pulse width or frequency, changes the current supplied to the LEDs towards the desired level. The power supply 208 may be AC or DC, although in the example shown it is DC. Current control provides constant brightness and prevents overheating. A typical pulse frequency for the current control may be 200 kHz to 4 MHz. This low voltage application shown here provides voltage for applications below about 72 volts.

[0052] The organization of the circuit boards 101 is shown in Figs. 15 and 16. Fig. 15 shows a single set of five LEDs 100 with circuit components 201, 202 and 203. Fig. 16 shows an exploded side view of an LED lighting system 10, with housing 102, cover 107 and with LEDs 100 secured to a circuit board 101 with heat sink compound 117.

[0053] Fig. 17 is an example of an LED lighting system or tube 10 in a mass transit application.

A transit vehicle has a body or hull 303 with a windshield 300. The break away shows floor 304, with seating 306 and partition 305. Lighting tubes 10 may be installed in pre-existing fluorescent light sockets or receptacles 309, with bypassing or removal of the fluorescent light ballasts 308. Fig. 26 is another view of the mass transit application, showing also passengers 310 and a reading plane 311 and floor plane 313, which acts as a test zone for establishing whether the LEDs are providing sufficient illumination. Figs. 18, 19 and 20 illustrate an application in which the LED lighting system 10 is used as part of an advertising sign 401 for a taxi 400. Figs. 21, 22 and 23 illustrate an application in which the LED lighting system 10 is used as part of an on duty sign 404 for a taxi 400. Figs. 24 and 25 illustrate installation of the LED lighting system 10 in new or pre-existing fluorescent light fixtures of an aircraft with a fuselage 500, seating 501, windows 502, upper luggage compartment 503, cargo area 504 and floor 505.

[0054] In Figs. 27A-27K, various shapes of cover lens 107 are shown including moderate convex 124, straight 107, straight raised 118, asymmetrically peaked 119 and 120, symmetrically peaked 121, raised dome 122, low dome 123, convex 124, depressed low dome 125 raised convex 126, and low dome with channel enclosing 127. Fig. 28 shows a fluorescent lamp fixture 600 with power receptacles or sockets 601, conventional ballast 602 for lamp 603, replacement LED lighting tube 10, ballast cover 604 and diffuser panel 605. While the lens 107 is not required for the final assembly it can be added to act as a guard against vandalism, as a dust/dirt guard, as a light enhancing device, as a light directing/focusing device, as a moisture/waterproofing device (sealing unit completely with the addition of sealant) or as a light diffuser. In Fig. 28, only the lighting tube 10 is new. Fig. 37 shows replacement of a fluorescent lamp 603 in a display sign application with an LED lighting tube 10 that fits between power receptacles 601. The ballast 602 may be removed or bypassed.

[0055] In Figs. 29-31, powered end of an LED lighting tube for a vehicle application includes LED 100 (one of several in the array), housing 102, connecting wires 103 that connect to the circuit board 101 and rivets 108 for securing the circuit board 101 on the housing 102. The connecting wires 103 pass through the holes 114 in O-rings 110 that are secured to the upstanding flange of an inner mounting bracket 116. The mounting bracket 116 is secured to the

housing 102 by a bolt 113 secured with nuts 112 and washer 111. Bolt 113 and nuts 112 also secure outer mounting bracket 115 to the housing 102. Rivets 108 also secure the side walls of the mounting bracket 116 to the channel walls of the housing 102. Mounting bracket 115 is used to connect the LED lighting tube of this embodiment to a structural portion of a vehicle. Figs. 32-34 show the non-powered end of the LED lighting system for a vehicle, which is the same as the powered end except that there are no power connections.

[0056] Fig. 35 shows electrical circuitry 30 of an onboard circuit board, and Fig. 36 shows several such boards connected in parallel between respective power buses. Figs. 35 and 36 show circuitry for a high voltage power source, above 72 volts, for example 120 volts to 240 volts, either AC or DC. The example shown here is for AC power supply. Fuse 215 protects the circuitry of the board from power surges. The fuse can be permanent or be a resettable fuse. Bi-directional filter circuit 204 filters out noise. Full wave rectifier 205 transforms AC current from the power bus (left side of figure) to DC current. The DC current from the full wave rectifier 205 is supplied to voltage regulator 207 to step the voltage down to a low level, for example 5 volts, to power switching power supply control IC 210. The switching power supply control IC 210 provides a modulated signal at about 250 kHz or more that determines the switching frequency or pulse width of a high voltage switching power driver circuit 211. The switching signal from driver 211 drives a primary coil of transformer 216, and causes DC voltage supplied by the full wave rectifier 205 to switch at the switching frequency or pulse width determined by the control IC 210. Transformer 216 couples this switching voltage through half-wave rectifier 206 which also filters the high frequency signal from the transformer 216 to the LED array 209 on the right side of Fig. 35. The half-wave rectifier 206 provides the switching frequency or pulse width of the current from the secondary of the transformer 216 and supplies a isolated feedback signal through a signal feedback circuit 212 to control IC 210. Depending on whether the sensed signal is above or below the desired current level, the control IC 210 varies the pulse width or pulse frequency of the signal driven by the driver circuit 211 to ensure a constant average current supplied to the LEDs. The transformer 216 both isolates input from the output, which drives the LEDs, and provides a voltage step down from high voltage above 72 volts, to low voltage required by the LED array 209. The control IC 210 may also be configured to vary the average current supplied to the LEDs, by suitable controlling the pulse width or frequency of

the drive signal to the circuit 211, and thus provide a dimmable controller that can be used to control the brightness of the lighting devices. The switching power supply circuit 30 may be mounted on each circuit board 101, or shared by each of several circuit boards 101 and located at one end of the lighting device 10.

[0057] The switching power supply circuit 30 is integrated with the LEDs 100 on each section of printed circuit board 101, so that any defect of each power supply circuits or LEDs 100 would not affect the lighting device 10 as a whole. The other circuit boards 101 of the lighting device are still active. The LED lighting device 10 can be installed in polarity or no polarity, and may have any required length. The LED lighting device 10 may use voltages from 1.5V ~ 240V in both DC and AC, and may fit retroactively into existing fluorescent lighting fixtures after removing or bypassing the ballast. This LED lighting device 10 can be a replacement or retrofit for all existing fluorescent lighting tubes larger than the size of T6.

[0058] Fig. 38 and Fig. 39 show two different views of an embodiment of an LED lighting system in which the LEDs 100 lie on flat PCB heat sinks 134. The LED arrays are attached to the flat PCB heat sinks with each of the LED arrays facing in a different direction. Each LED array contains a series of LEDs, each with a conical beam, that together create an illumination field. The orientation of the illumination fields of the LED arrays shown in Figs. 38 and 39 are angularly offset from each other by 90 degrees. In other embodiments, this angle may change, and/or individual LEDs may have conical beams that are angularly offset from each other. Additional LED arrays may also be provided, with each LED array having a differently oriented illumination field. In one embodiment, the illumination fields of three or more LED arrays may together make up a 360 degree pattern. In the embodiment of Figs. 38 and 39, an 180 degree lens with guides 133 is attached to the housing 133 in grooves 109, and may slide into place along the grooves 109. In Fig. 39, two PCB heat sink channels 135 are formed in the housing 102. The heat sinks 134 fit in the channels 135. Heat from the heat sinks 134 is in part communicated to the housing 102 to assist in heat dissipation. A suitable high heat conductive material such as aluminum may be used for the heat sinks 134 and housing 102.

[0059] Immaterial modifications may be made to the embodiments described here without departing from what is claimed.

What is claimed is:

1. An LED lighting system, comprising:
 - a housing forming a channel spanning between a first end and a second end, the channel having side walls;
 - the housing forming a rigid backbone structure having a length between the first end and the second end and having a width, the length being longer than the width;
 - the first end and the second end of the housing each having electrical connectors for connection to a power source;
 - an LED array divided into sets of LEDs, the LED array extending along the length of the housing within the channel, each LED in the LED array having a power rating of greater than 0.5 watts;
 - the housing being sufficiently heat conductive to provide heat dissipation for the LEDs;
 - current control circuitry for the LED array, the current control circuitry being carried by the housing and located within the channel and being in electrical communication with the electrical connectors;
 - the current control circuitry being formed of multiple current controllers, each current controller of the multiple current controllers providing current control for a corresponding set of LEDs in the LED array;
 - a domed transparent or translucent cover secured to the side walls of the housing over the channel; and
 - the first end and the second end of the housing each being capped by respective caps that prevent movement of the transparent or translucent cover in relation to the housing.
2. The LED lighting system of claim 1 in which the electrical connectors at each of the first end and the second end of the housing are fluorescent light receptacle attachment pins.
3. The LED lighting system of claim 1 or claim 2 in which the housing is made of a

unitary piece of material that is both heat conductive and rigid.

4. The LED lighting system of any one of claims 1-3 in which the current control circuitry is configured to provide constant current to the LEDs of the LED array.
5. The lighting system of any one of claims 1-4 in which the side walls of the housing have a curvature, and the domed transparent or translucent cover forms a continuation of the curvature of the side walls.
6. The lighting system of any one of claims 1-5 in which the LED array is supported by a circuit board and the corresponding current control circuitry is provided on the circuit board.
7. A lighting system comprising multiple LED lighting systems according to any one of claims 1-6 installed in or on a vehicle.
8. The lighting system of claim 7 in which the vehicle is a watercraft, aircraft or land vehicle.
9. A lighting system comprising multiple LED lighting systems according to any one of claims 1-6 installed in a building or in signage.

FIG. 1

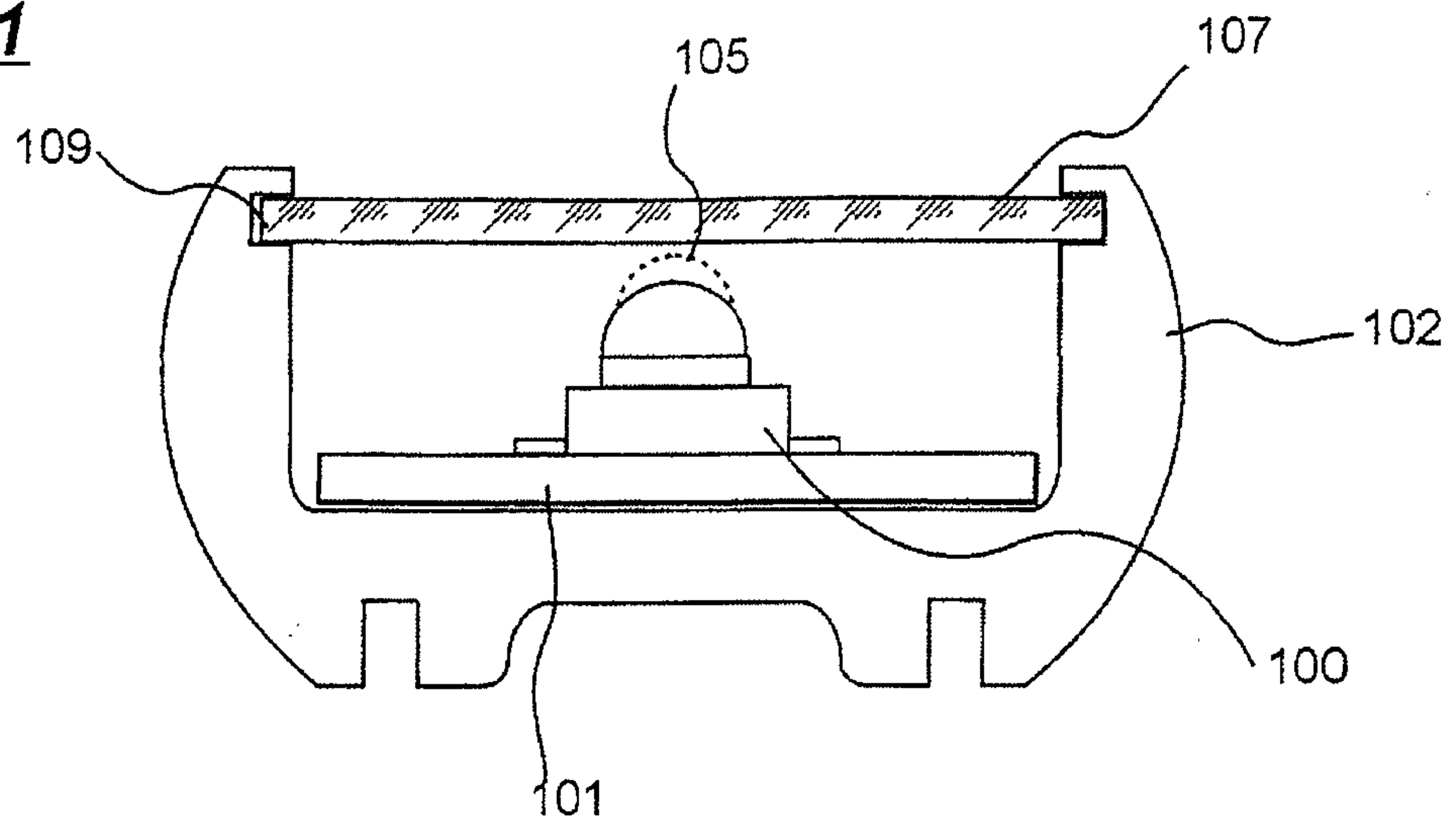

FIG. 2

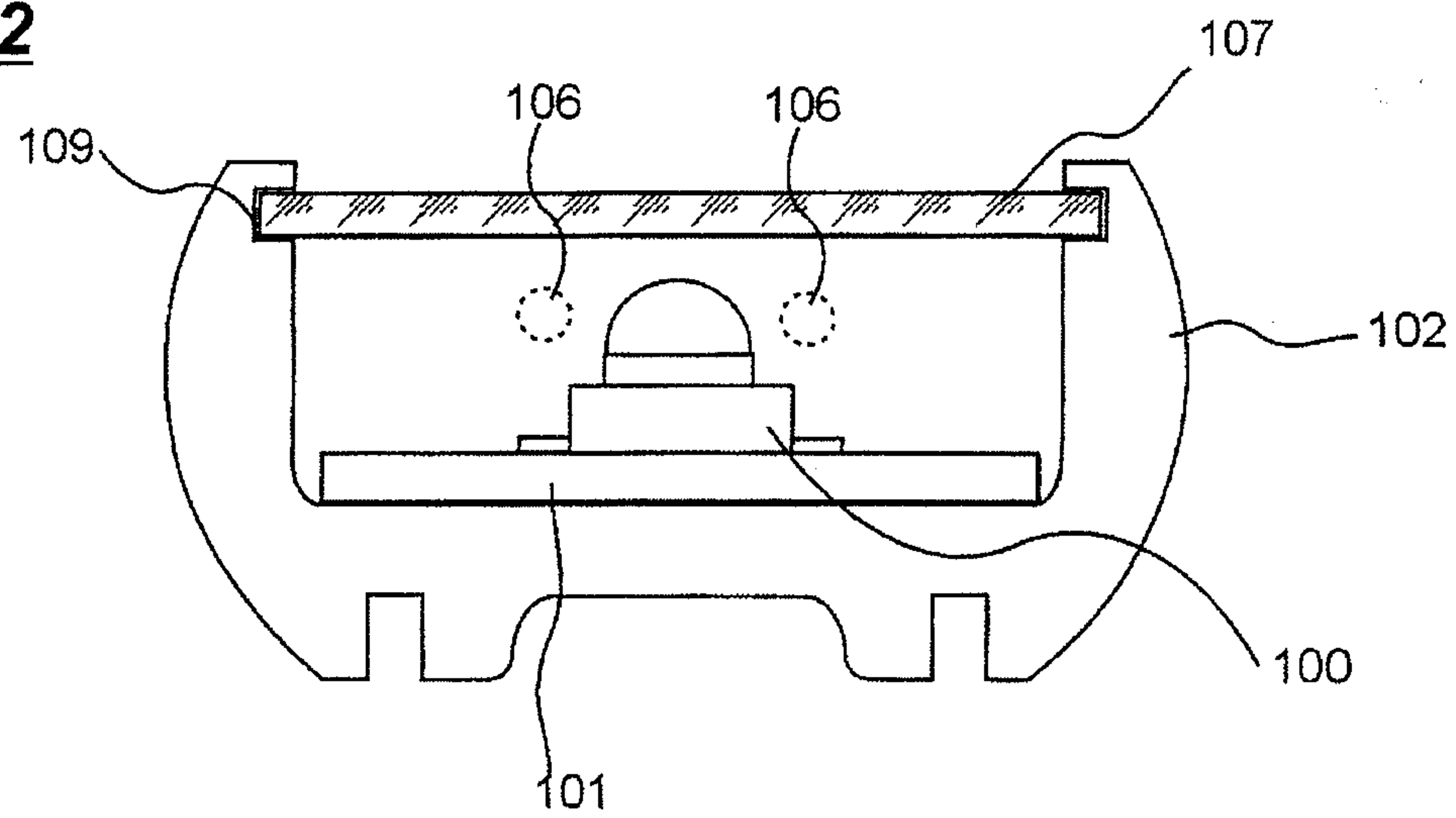

FIG. 3

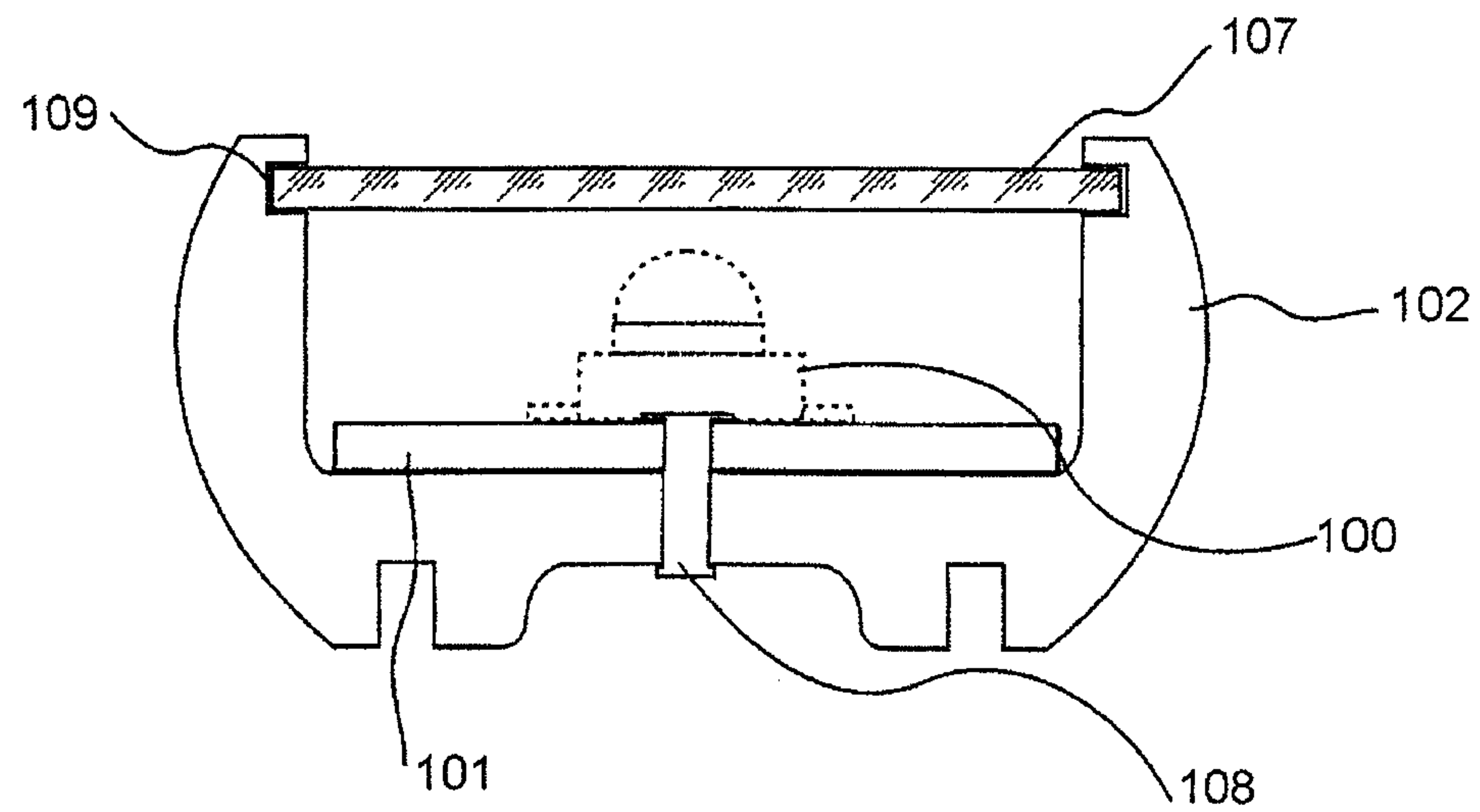

FIG. 4

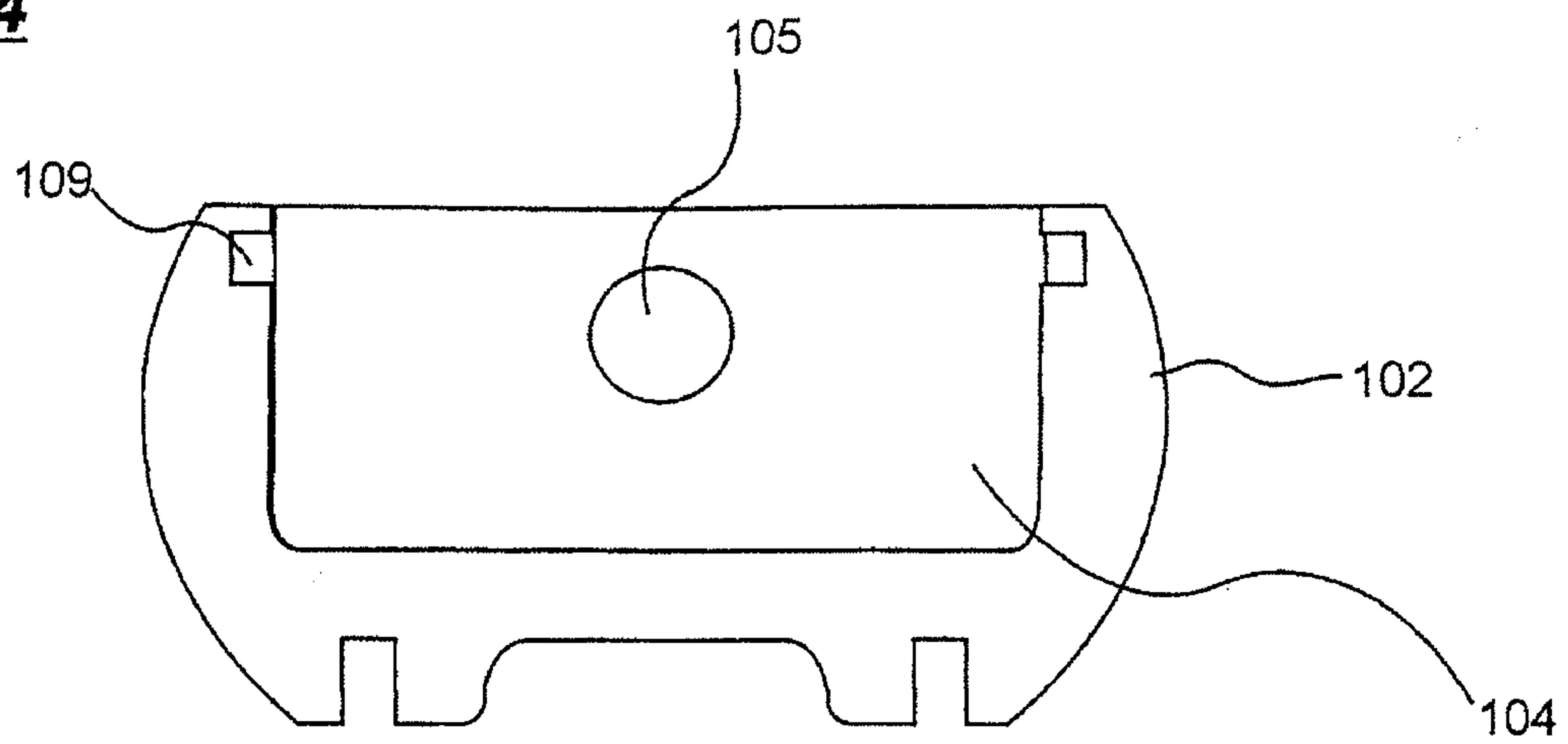

FIG. 5

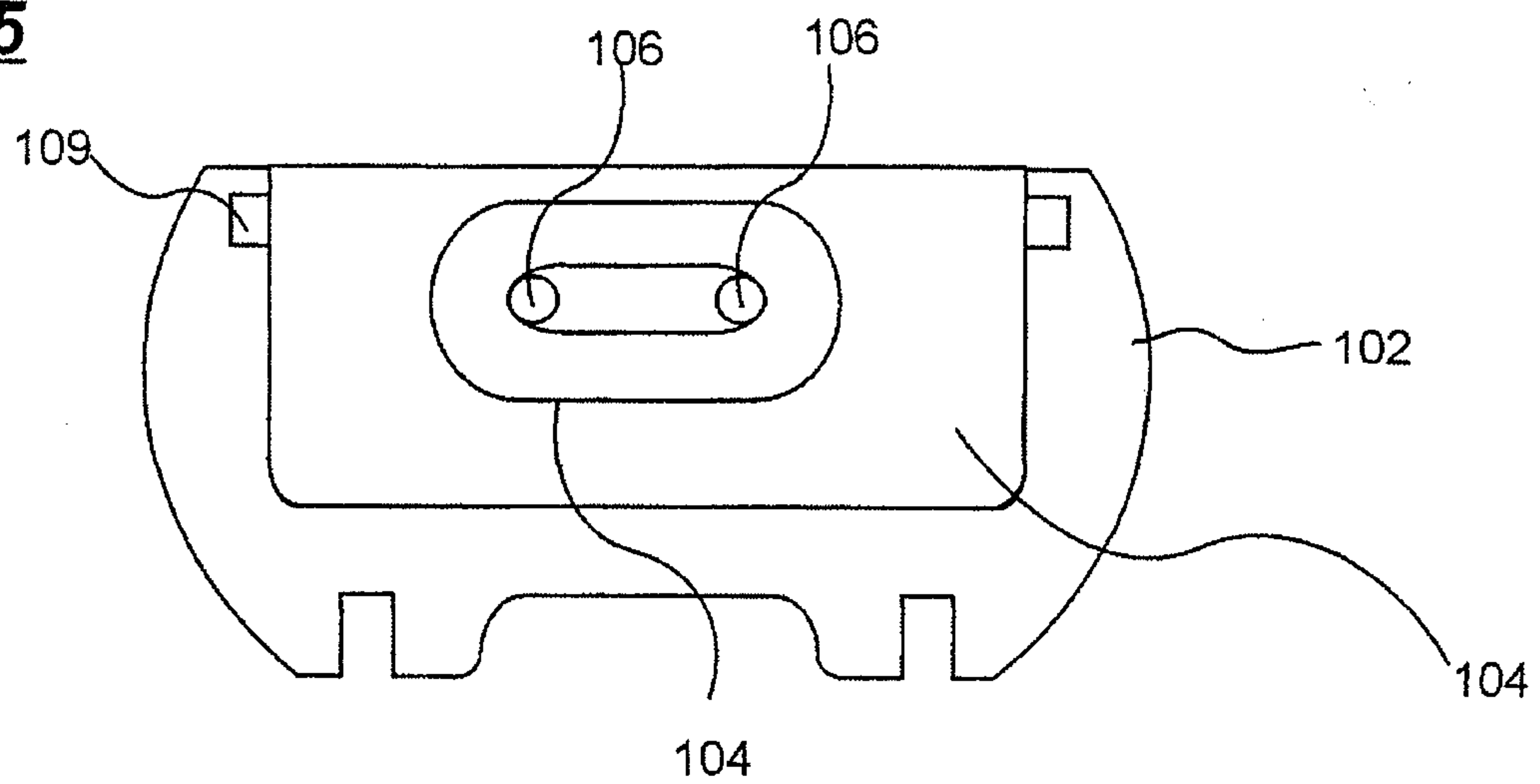
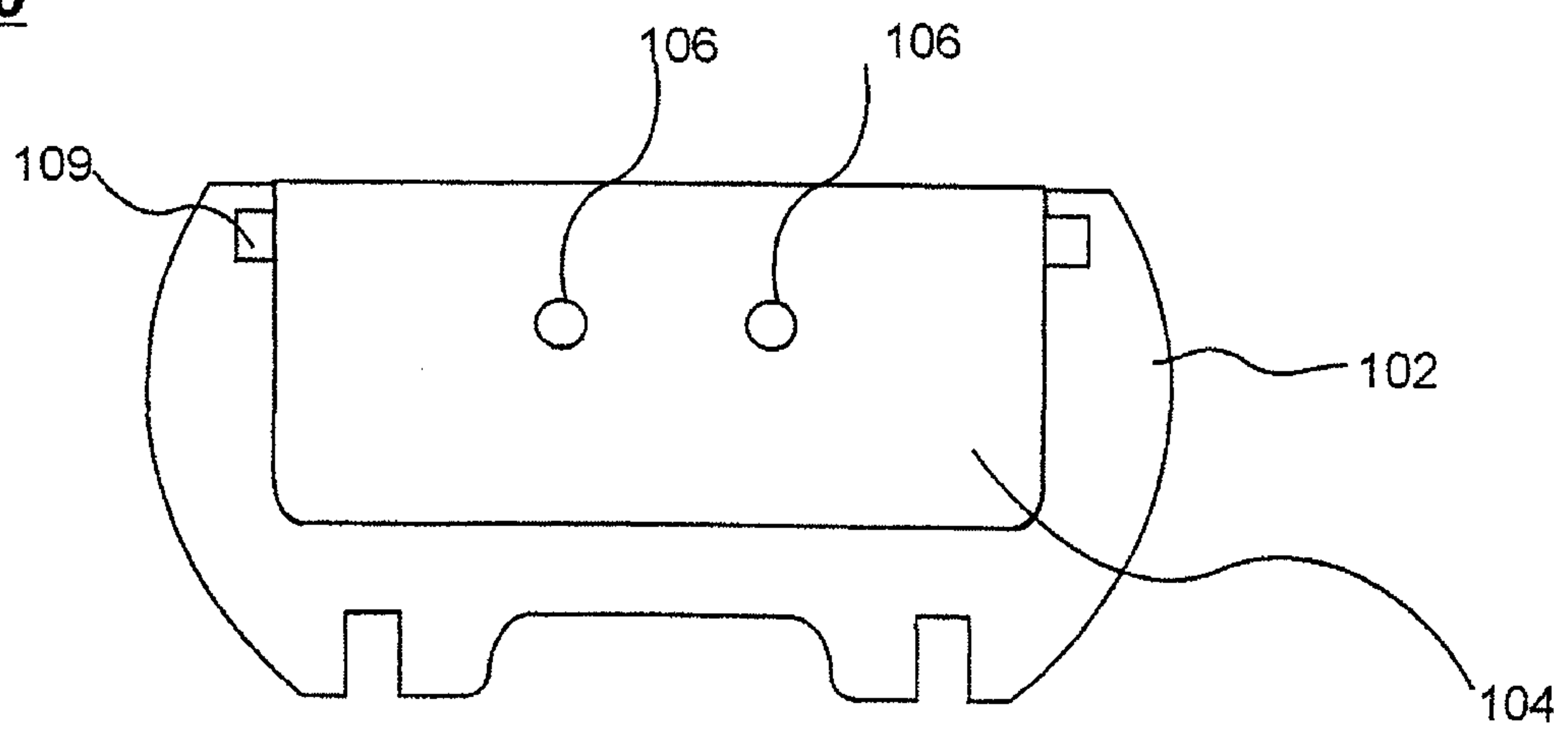
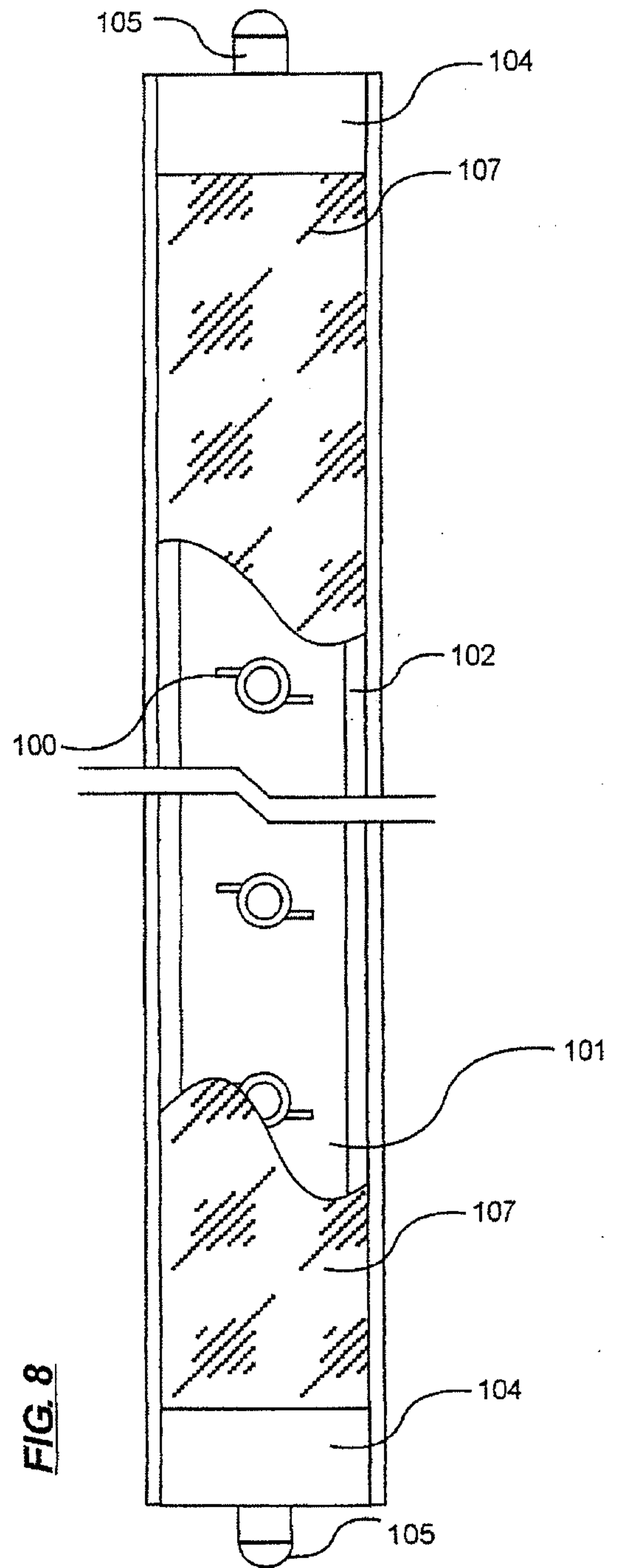
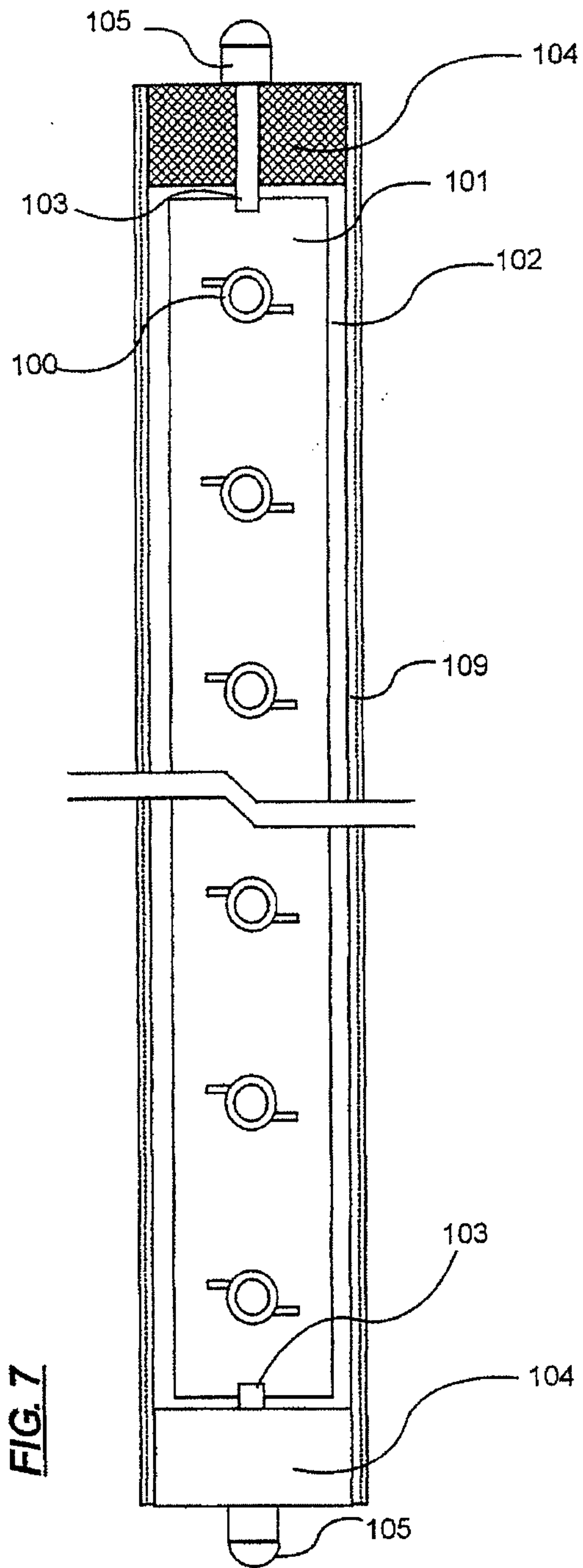

FIG. 6





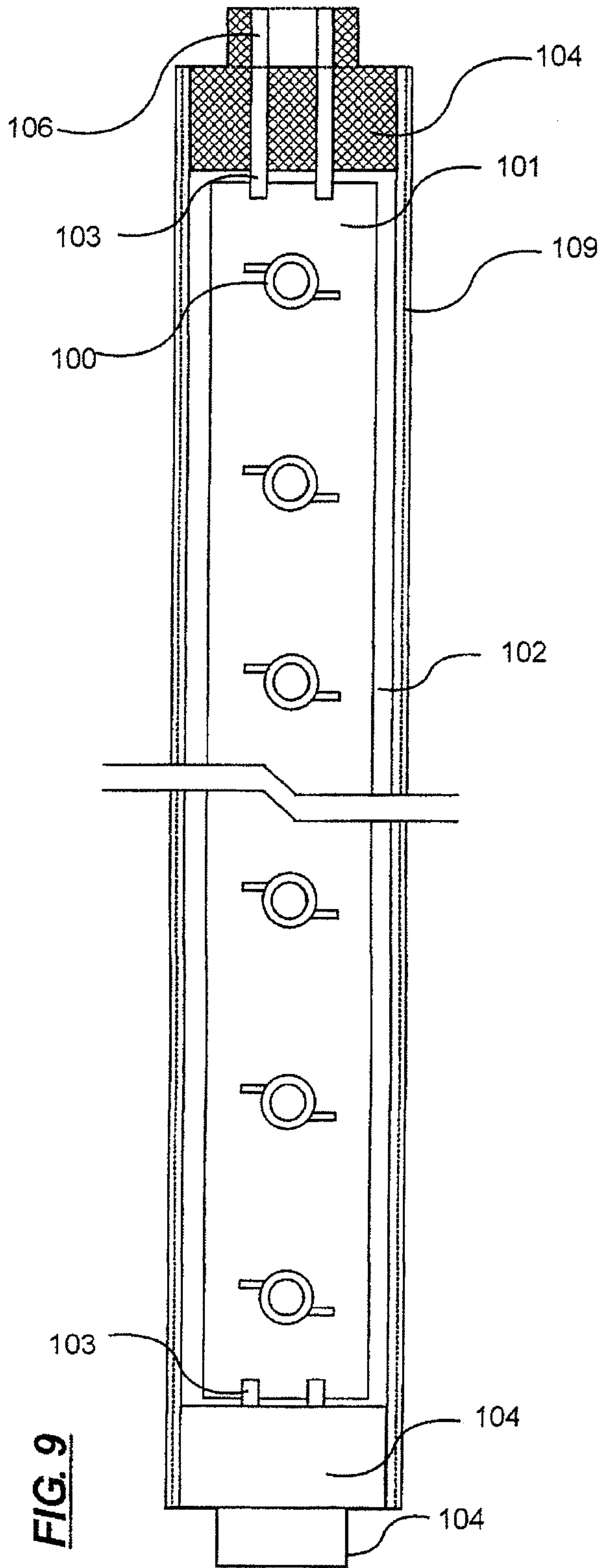

FIG. 9

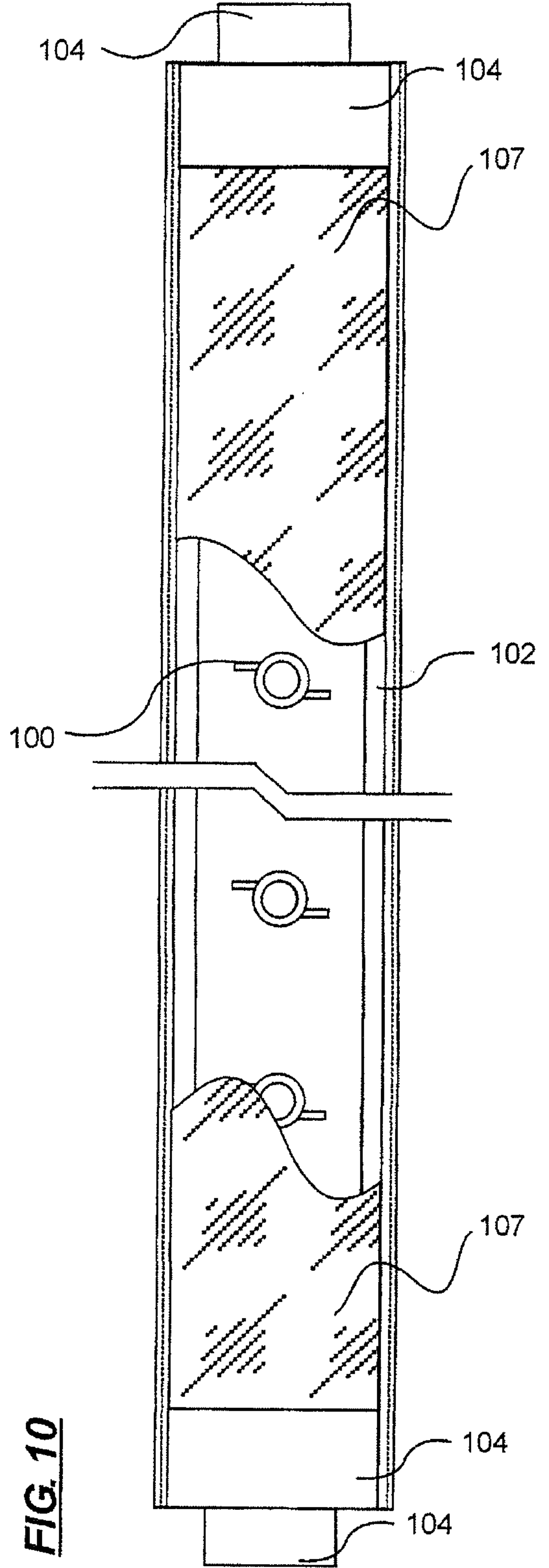

FIG. 10

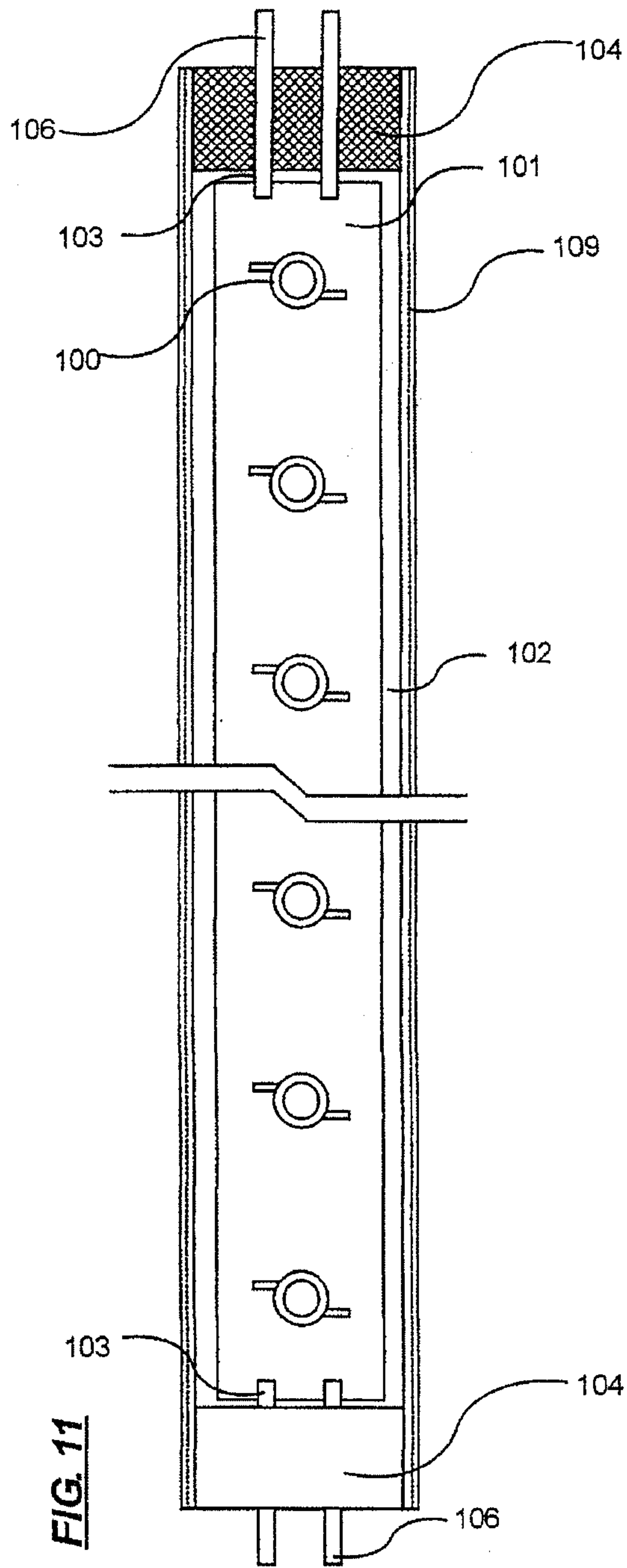

FIG. 11

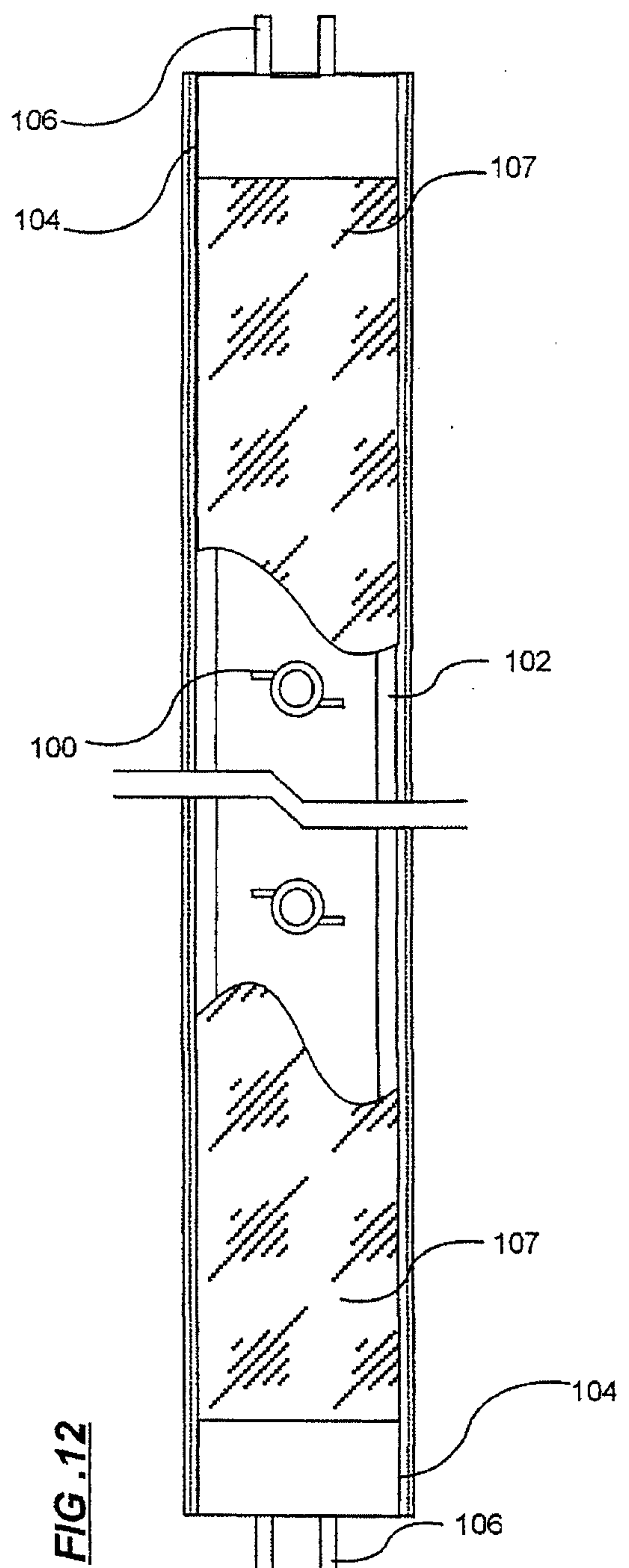
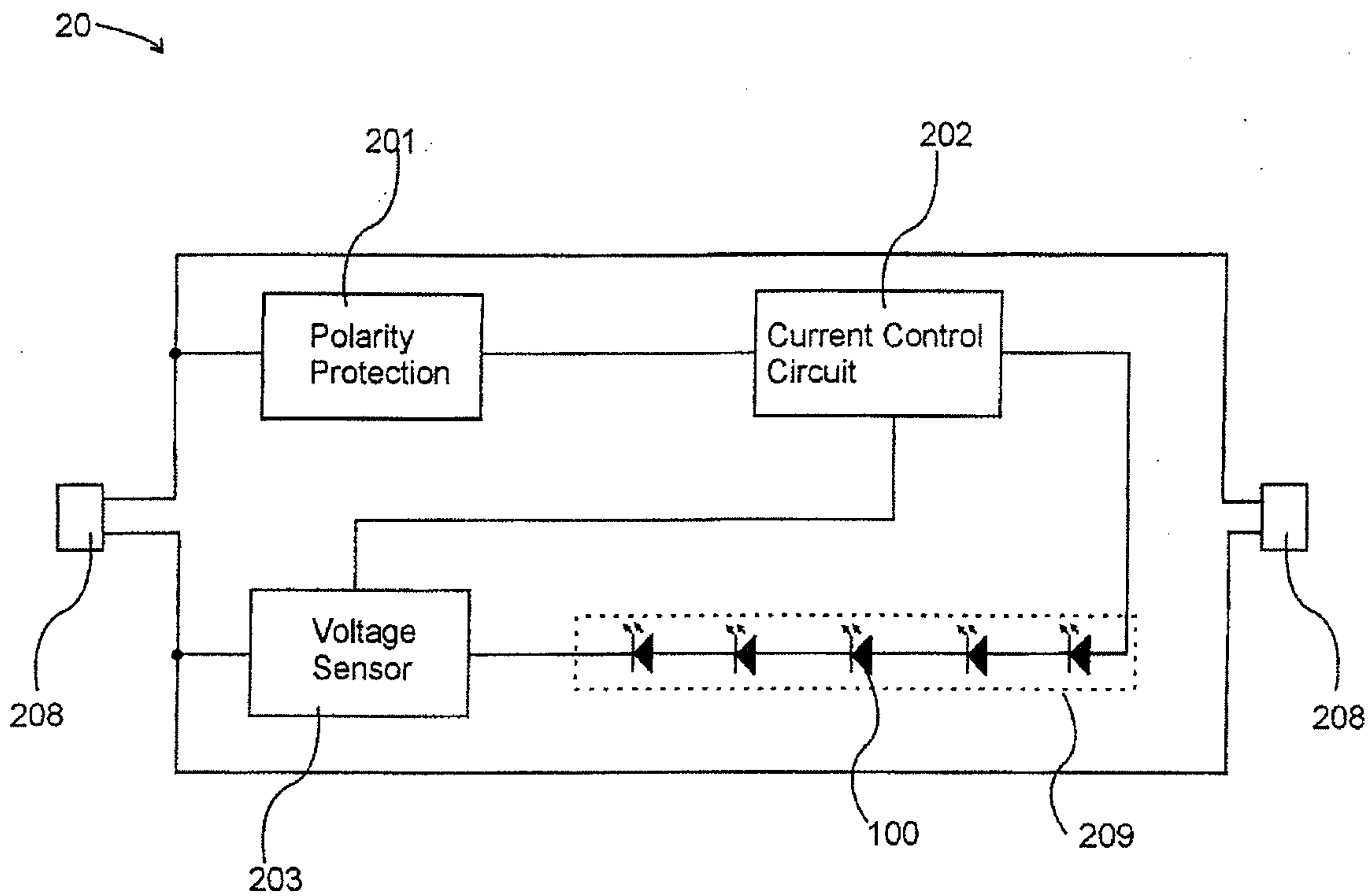

FIG. 12

FIG. 13



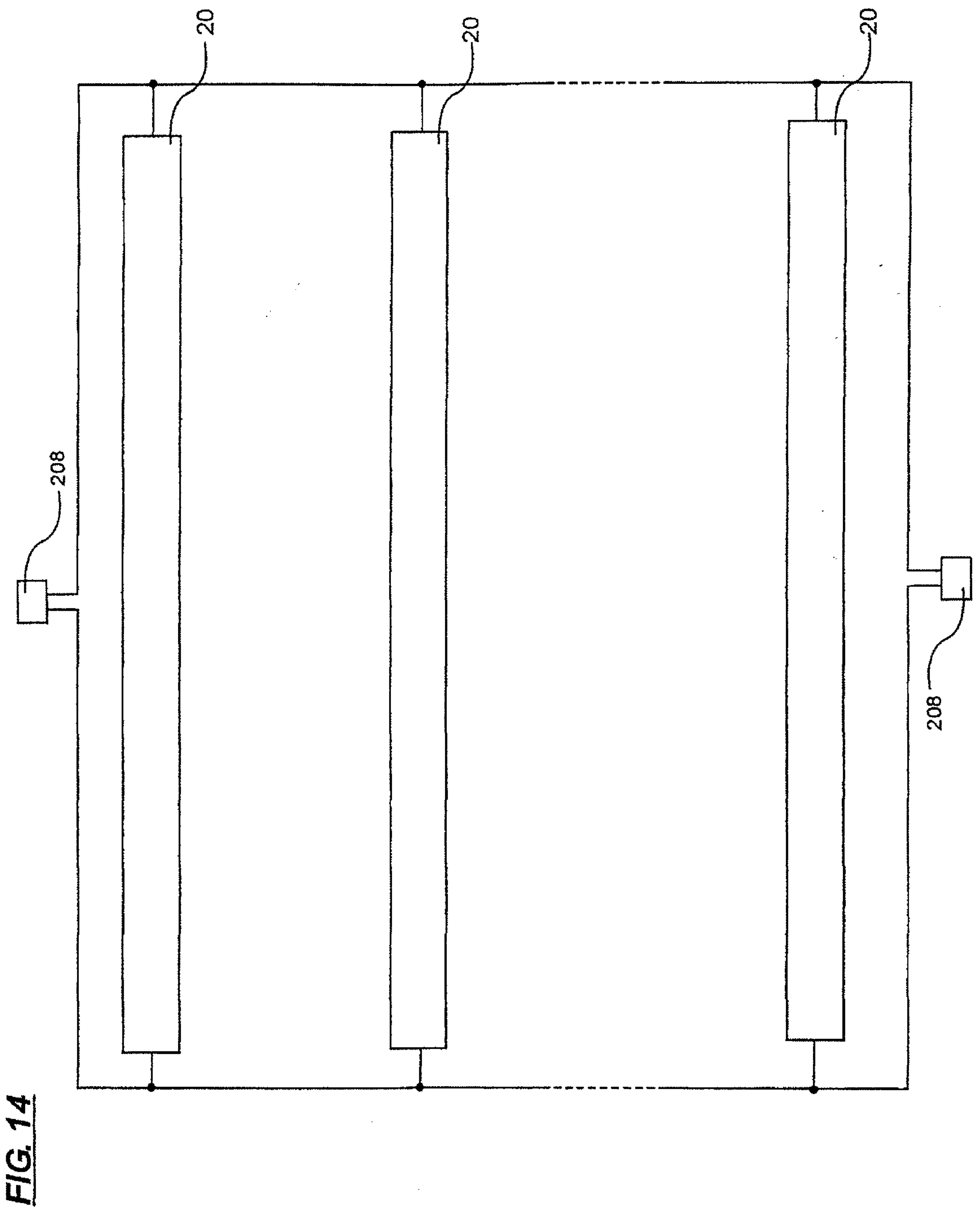

FIG. 14

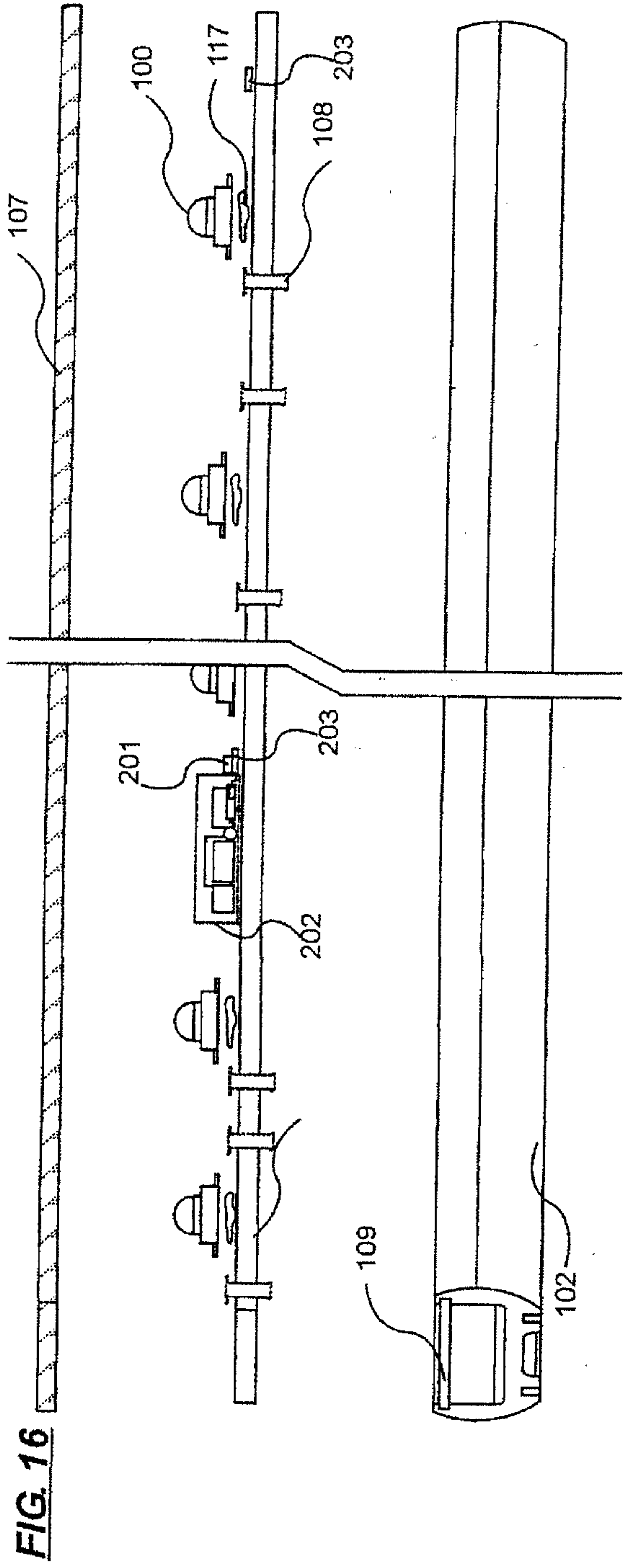
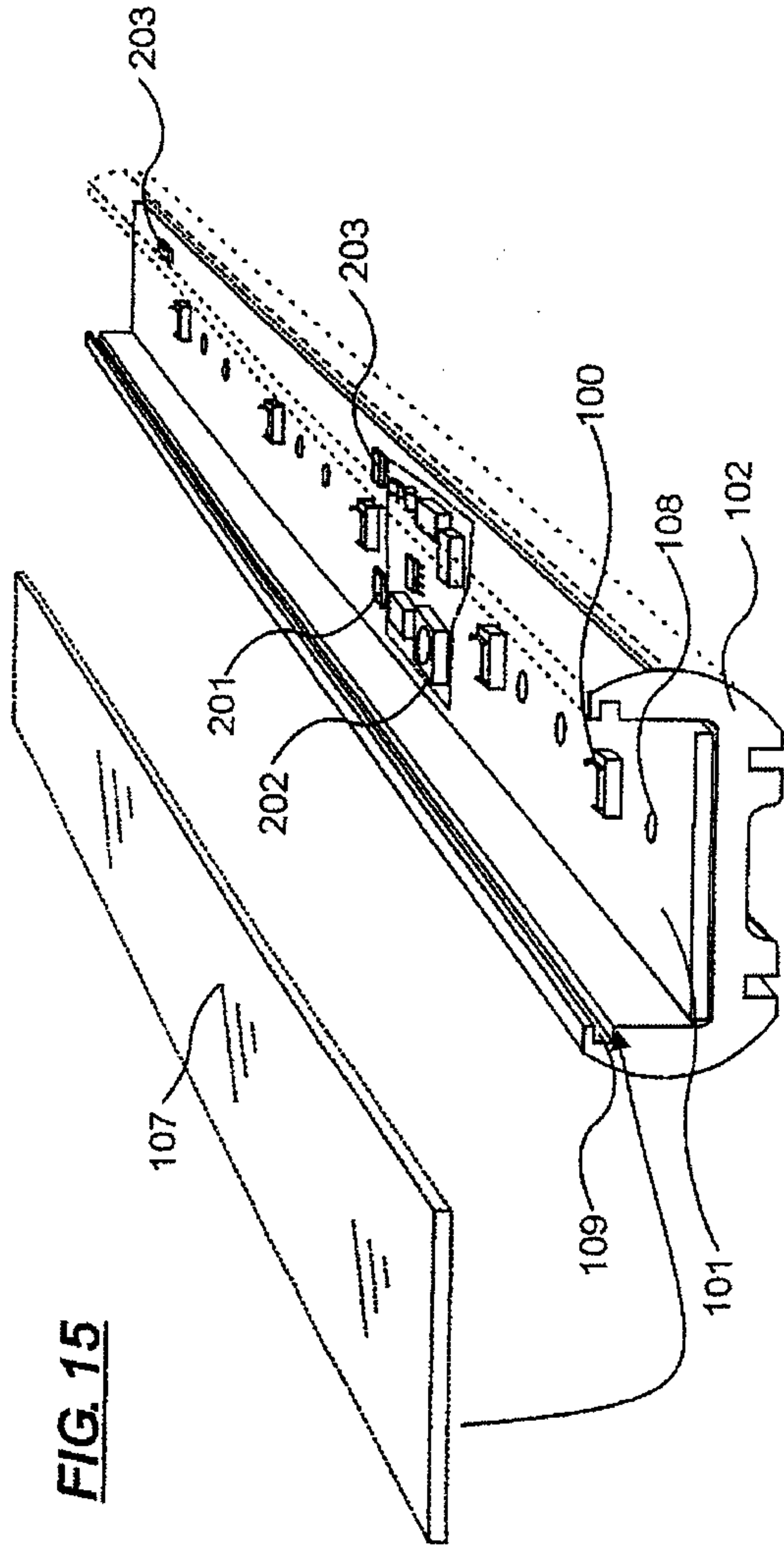

FIG. 17

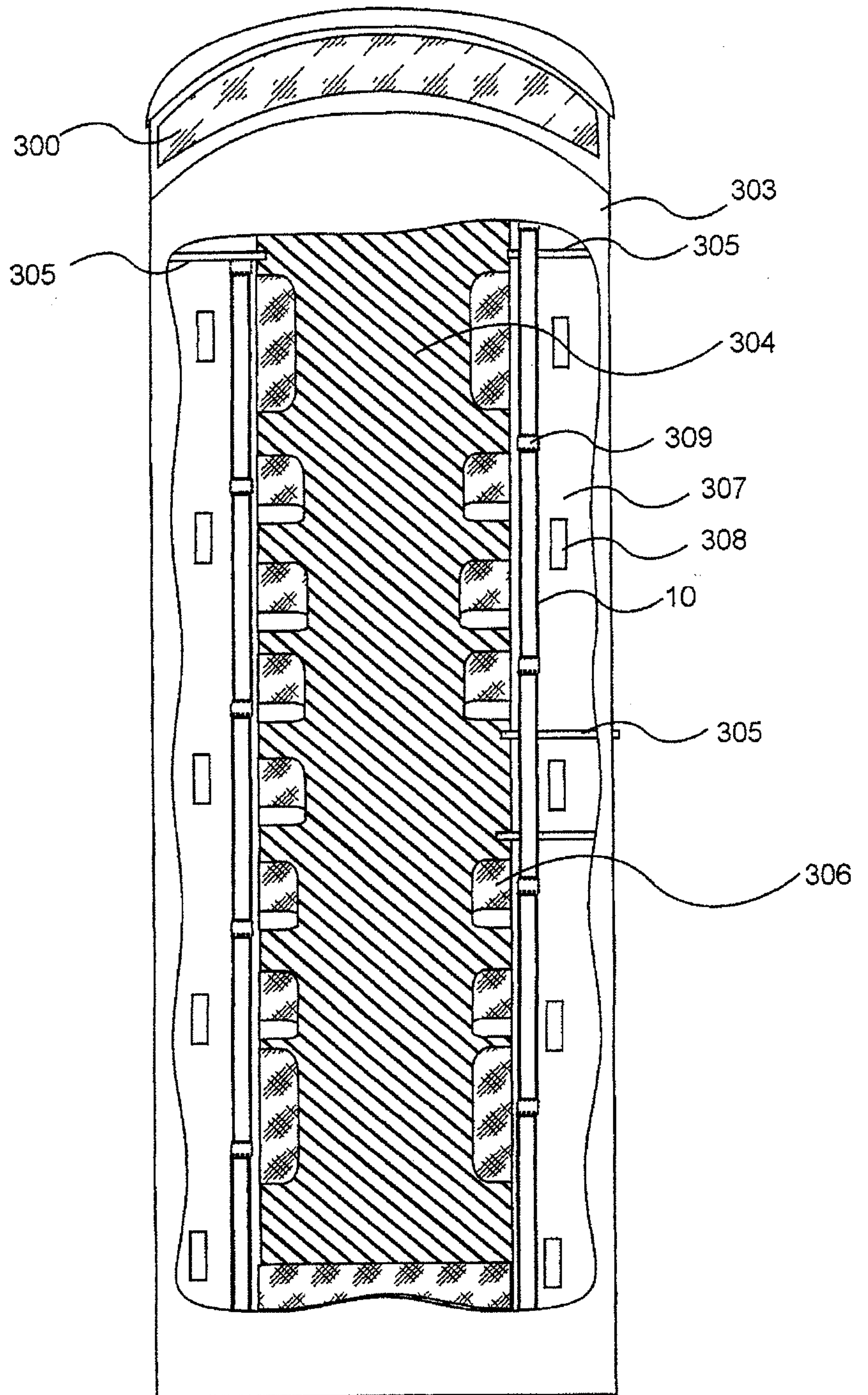

FIG. 18

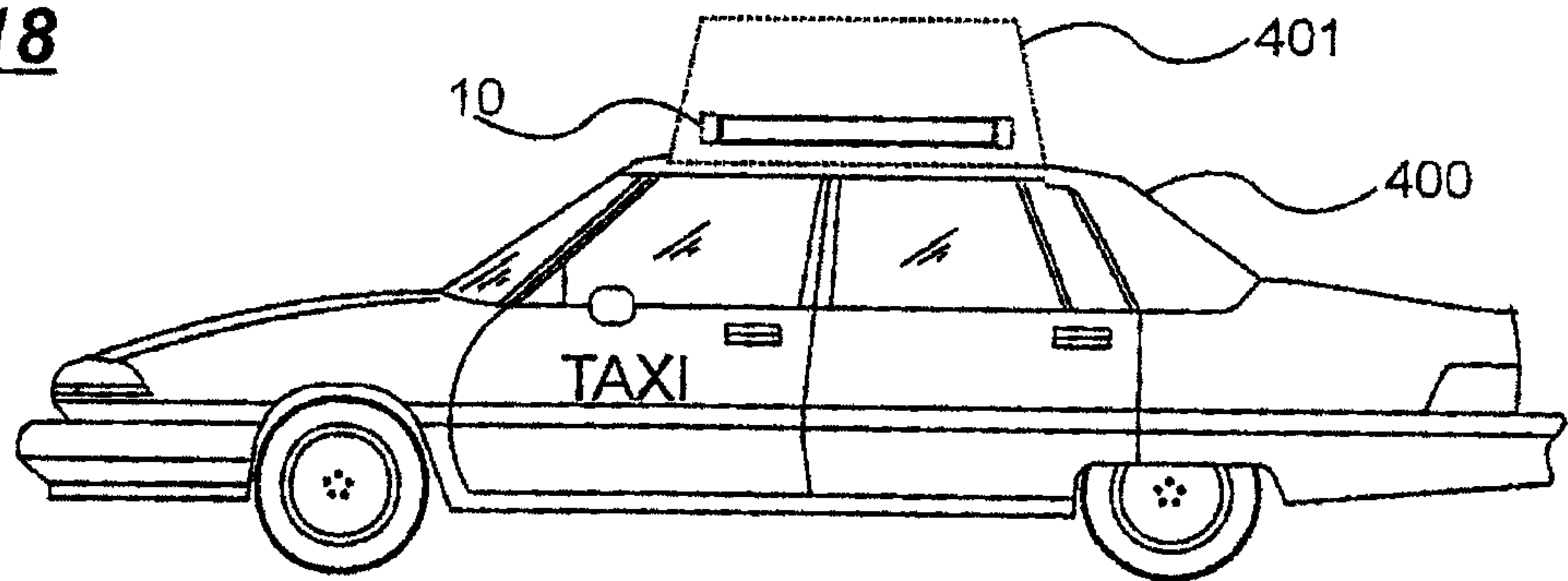

FIG. 19

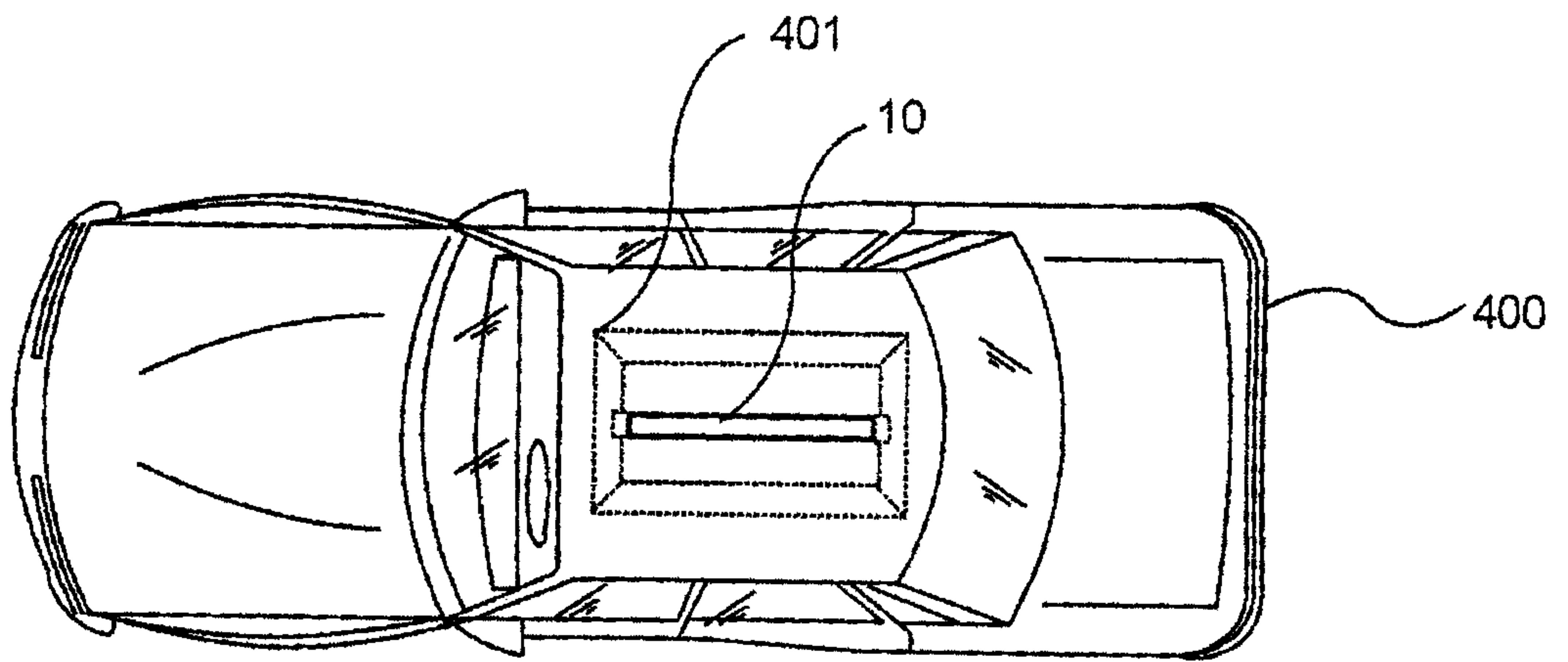

FIG. 20

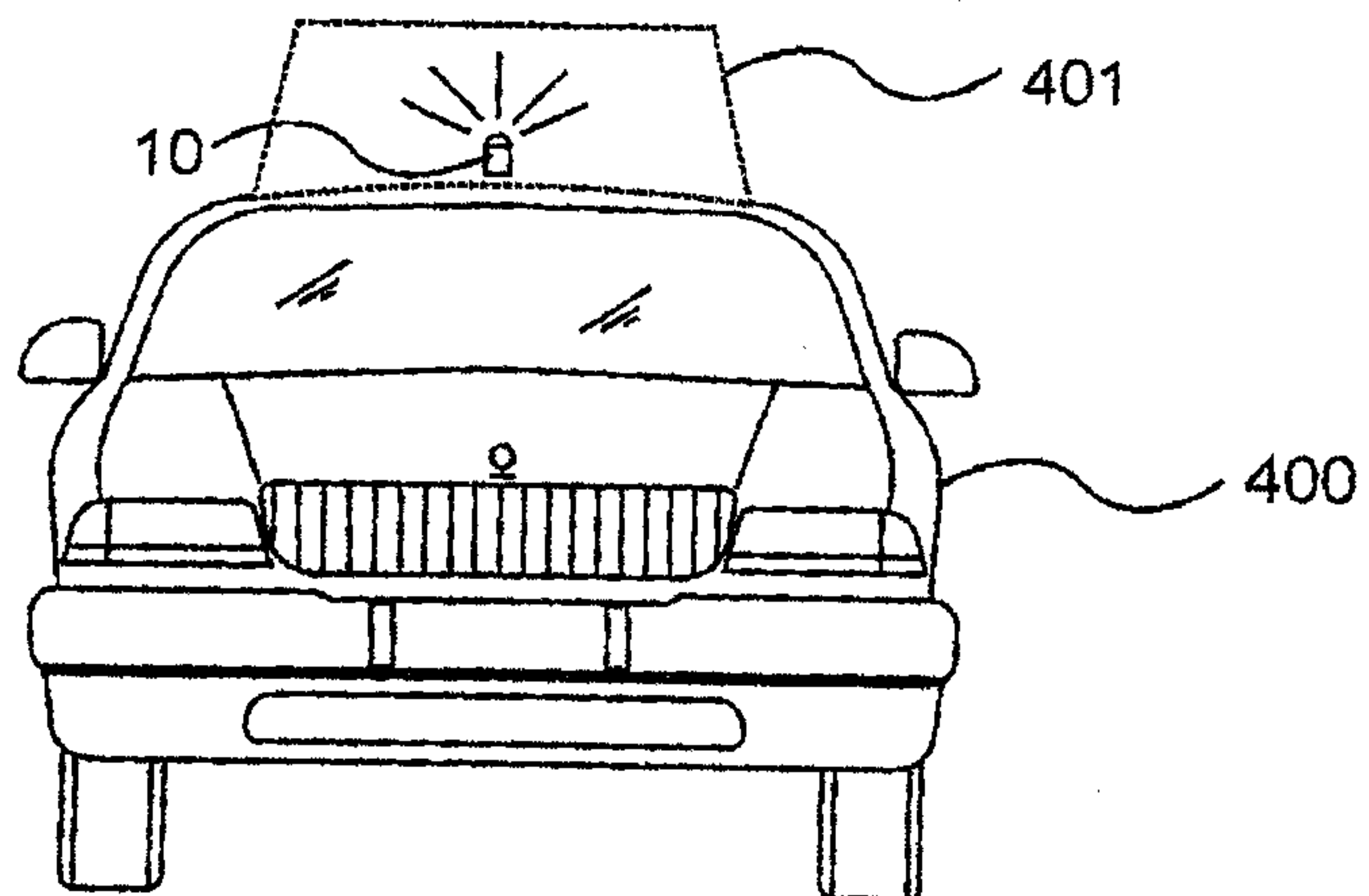

FIG. 21

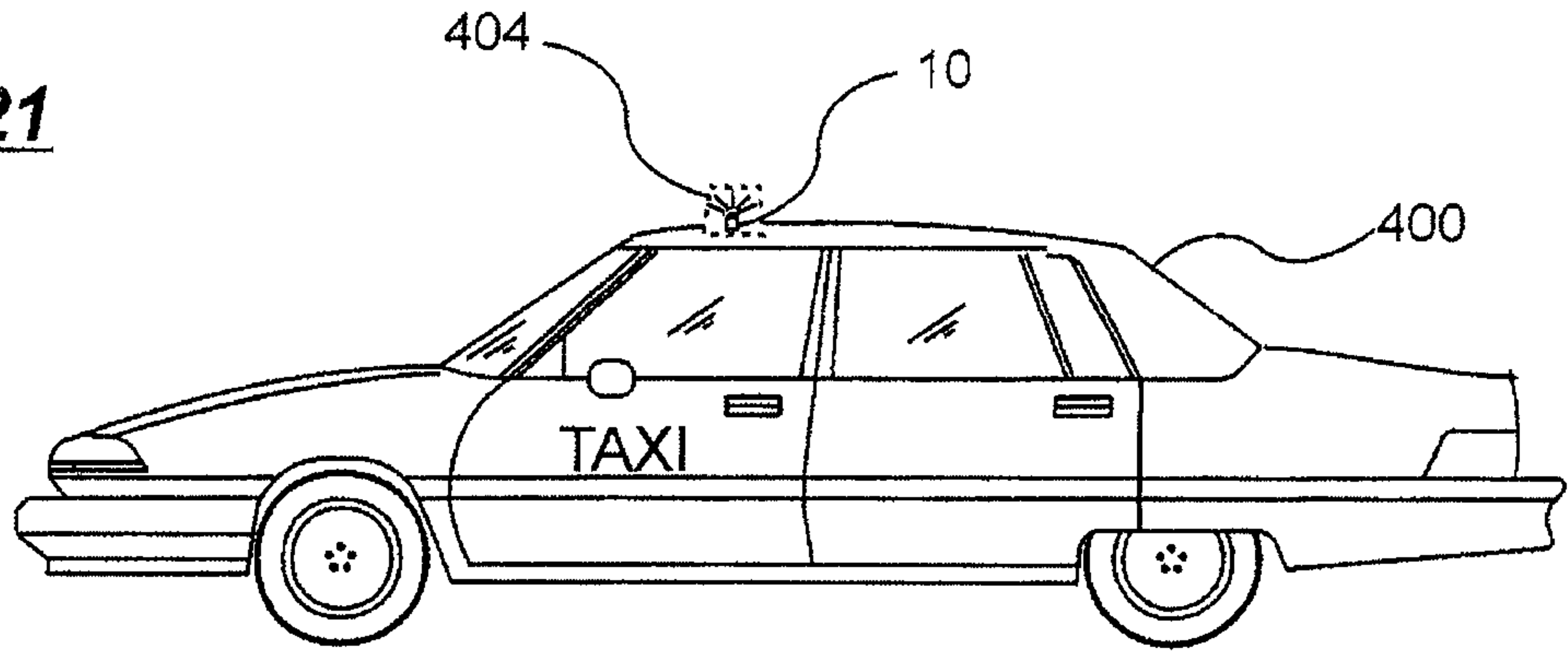

FIG. 22

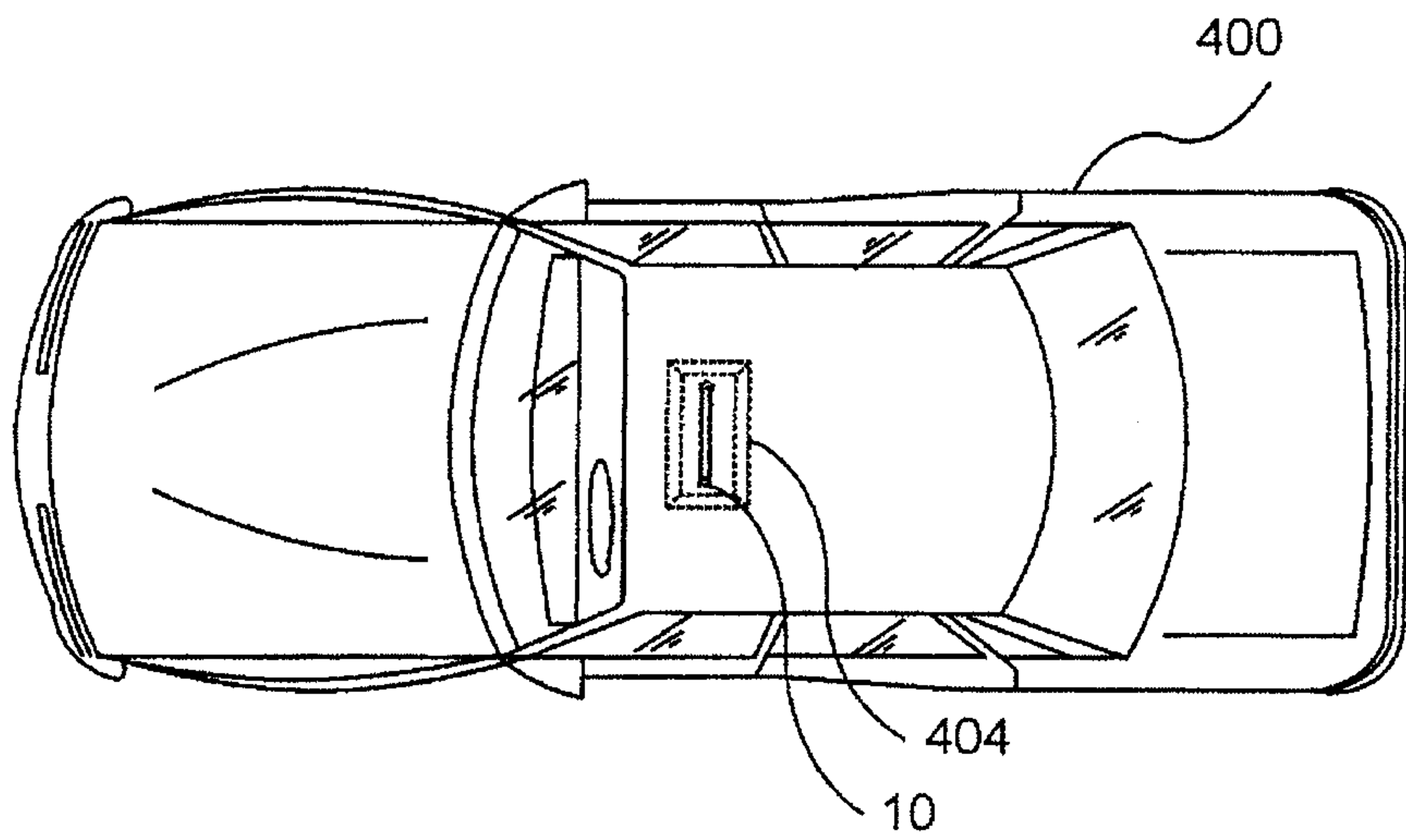

FIG. 23

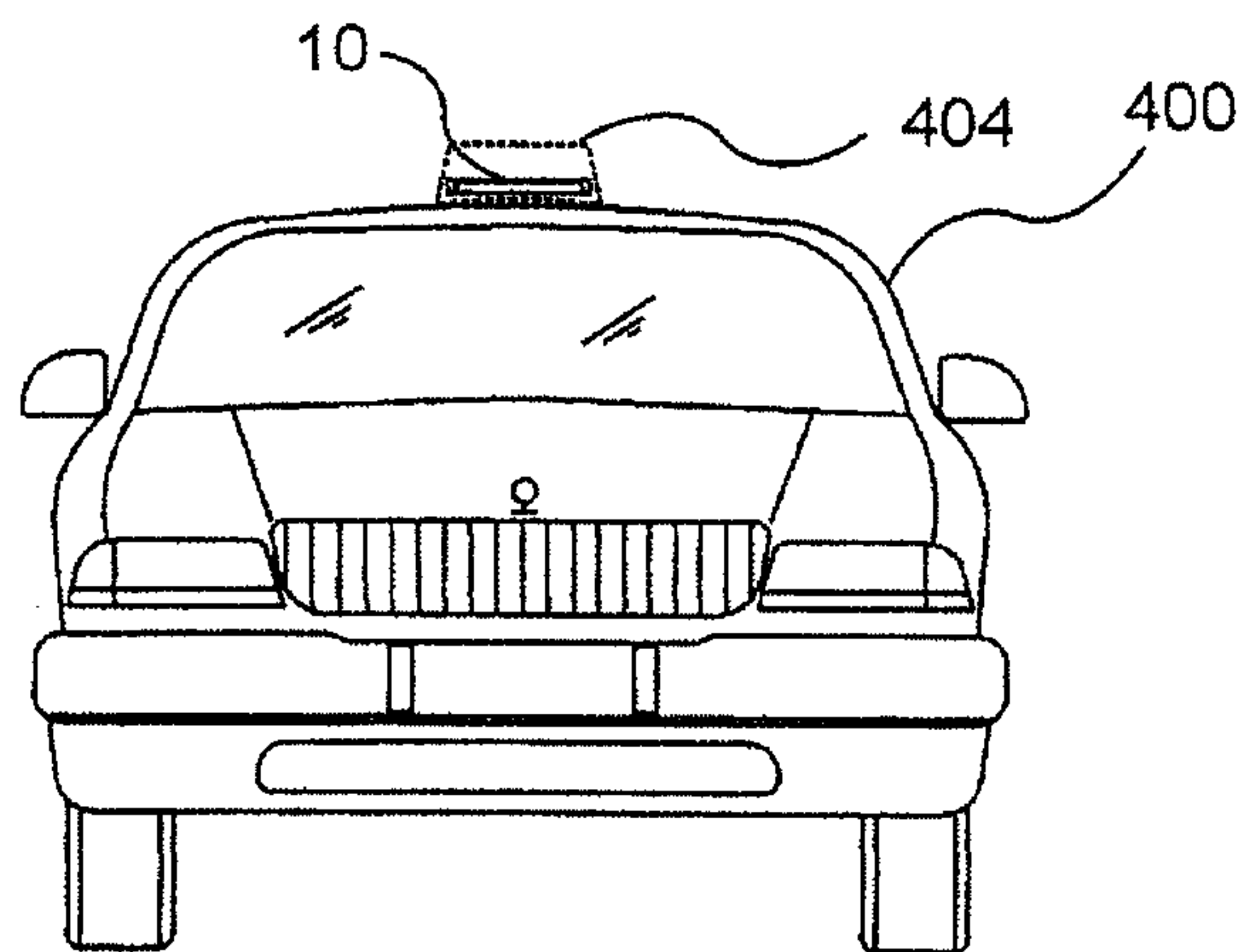

FIG. 24

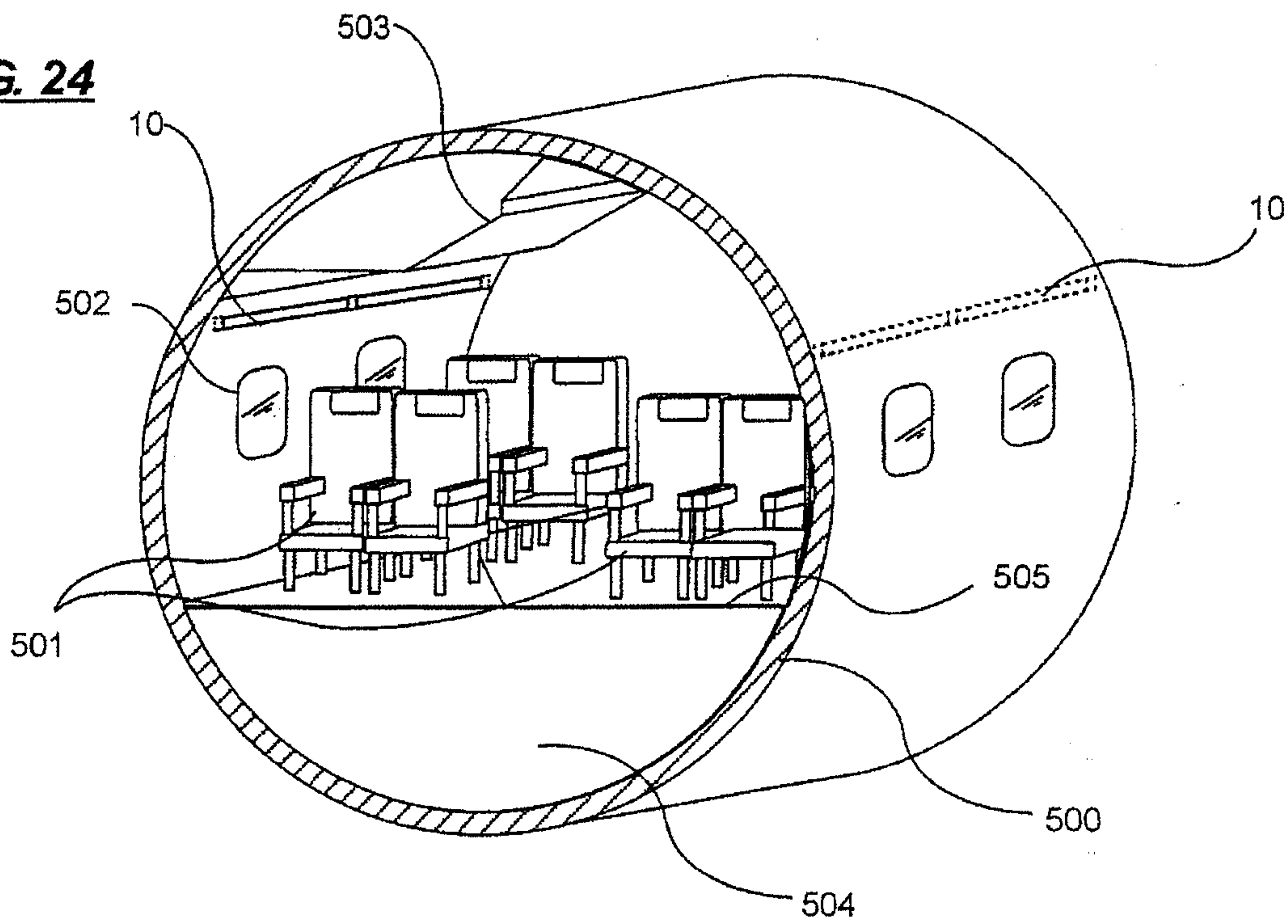

FIG. 25

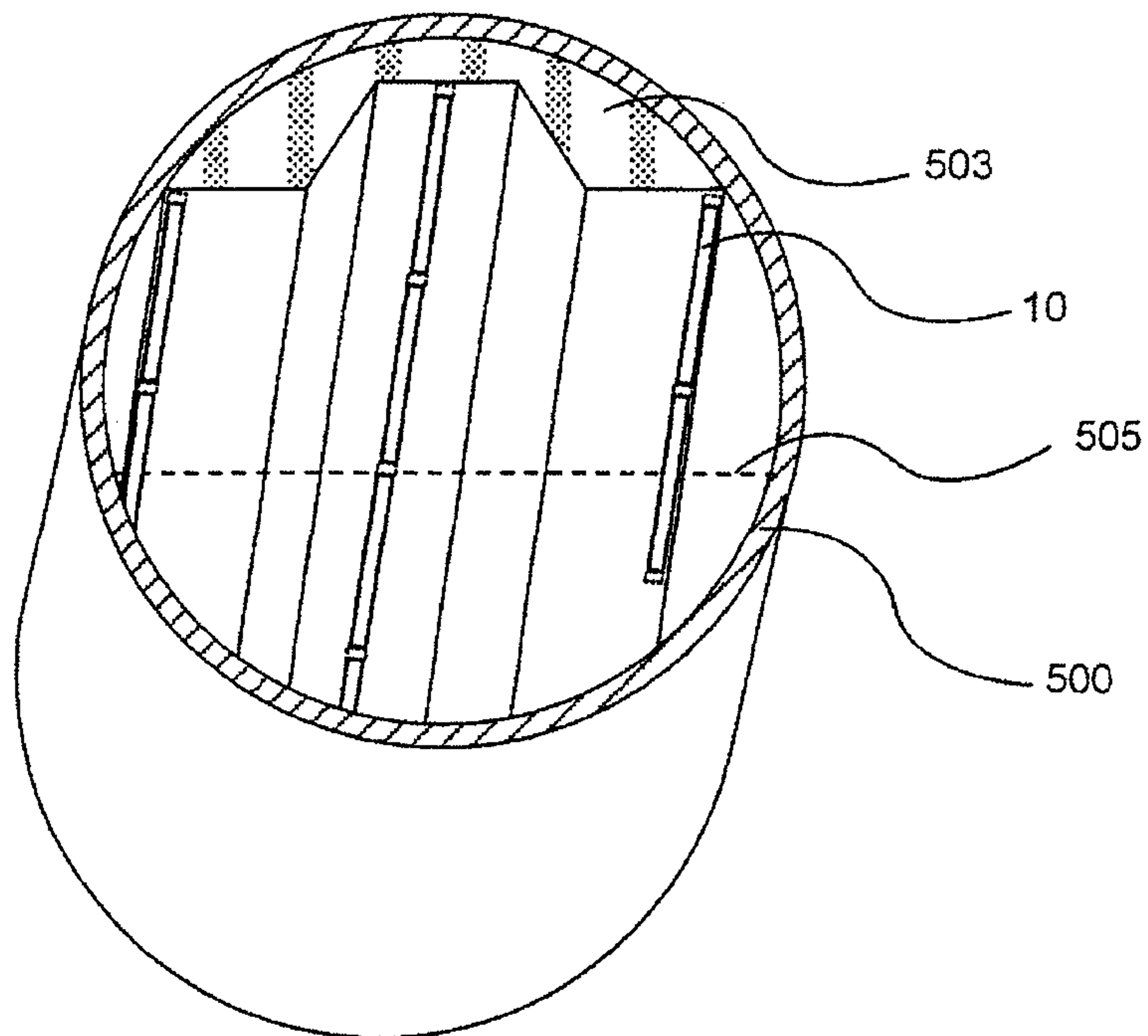

FIG. 26

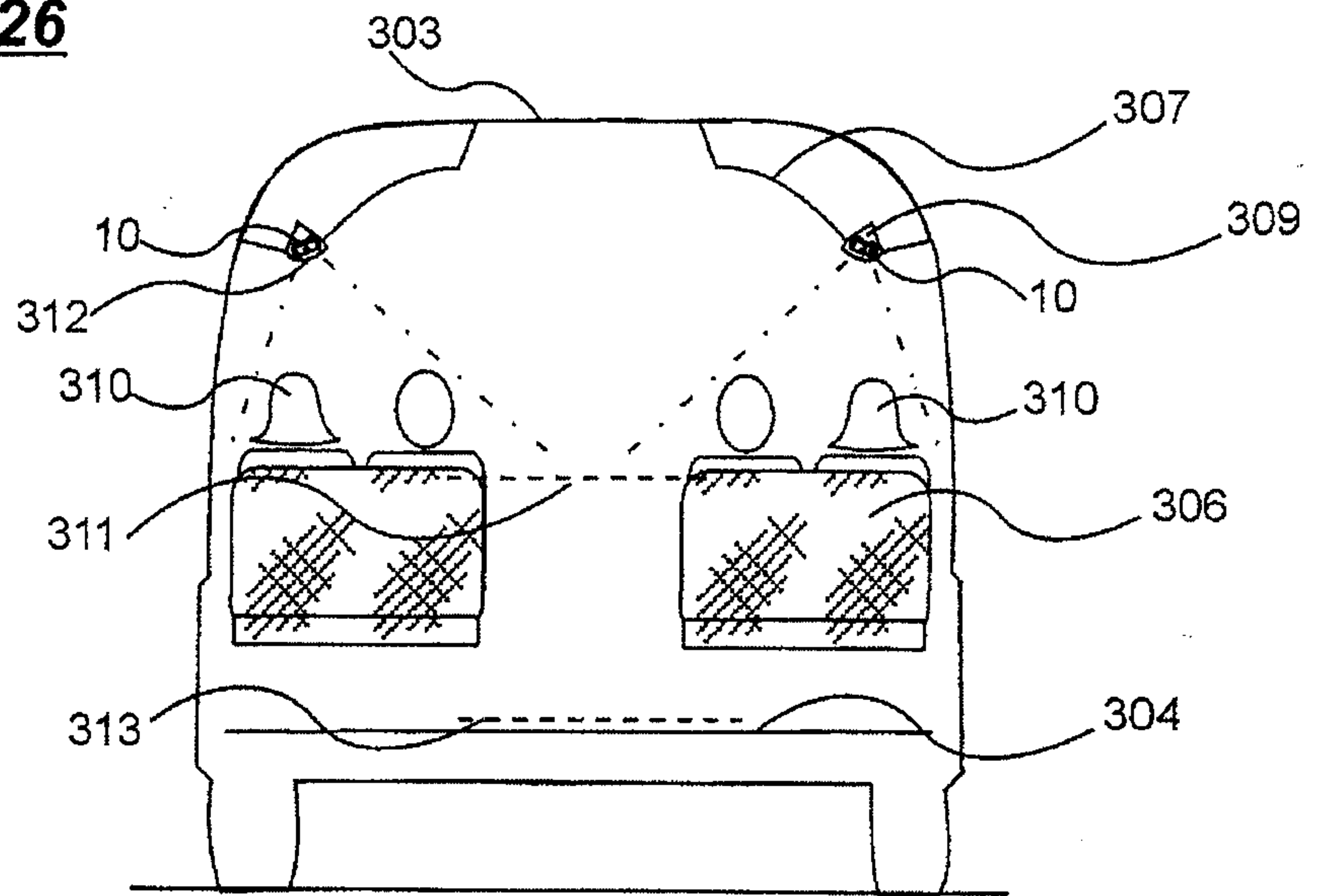

FIG. 27

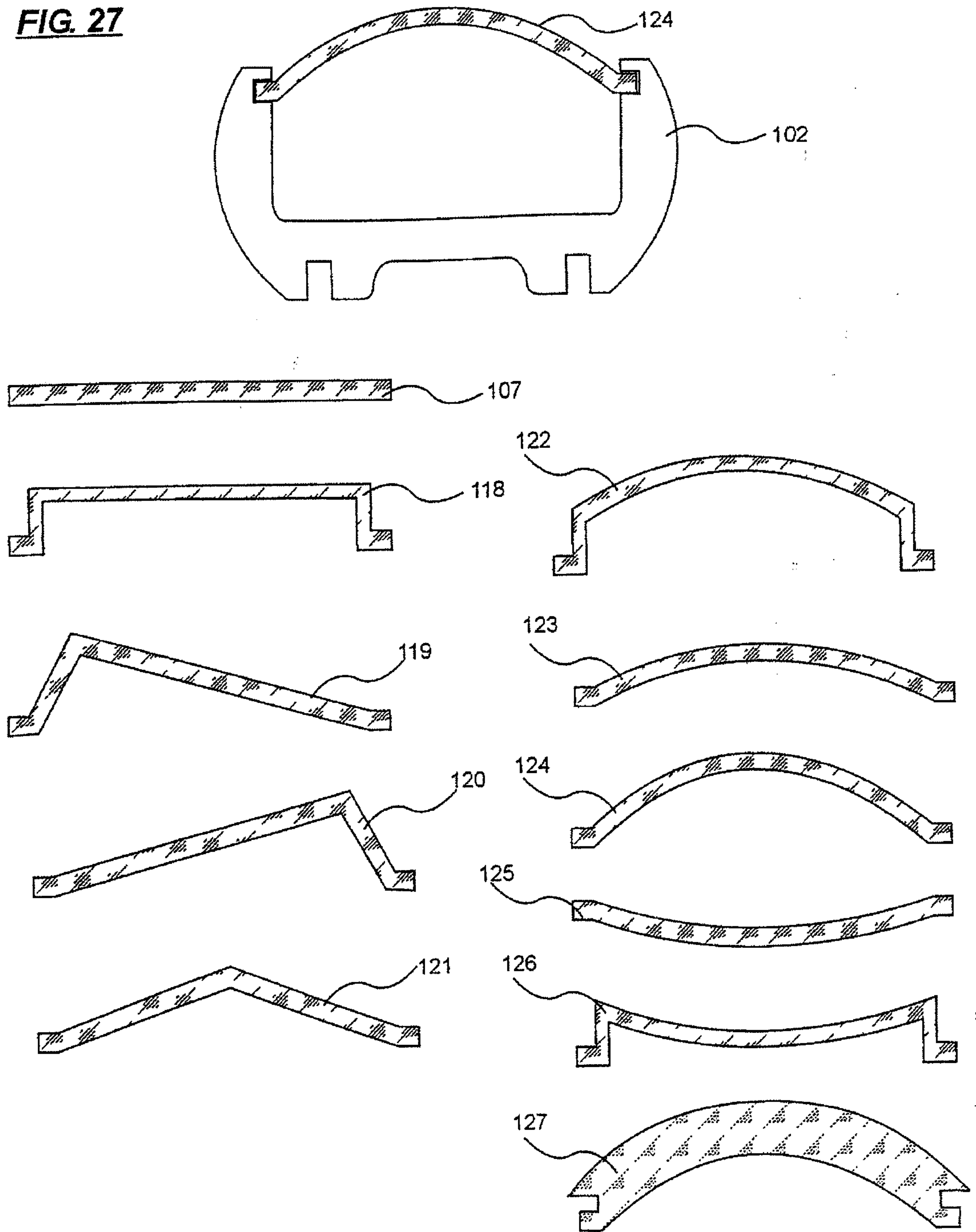

FIG. 28

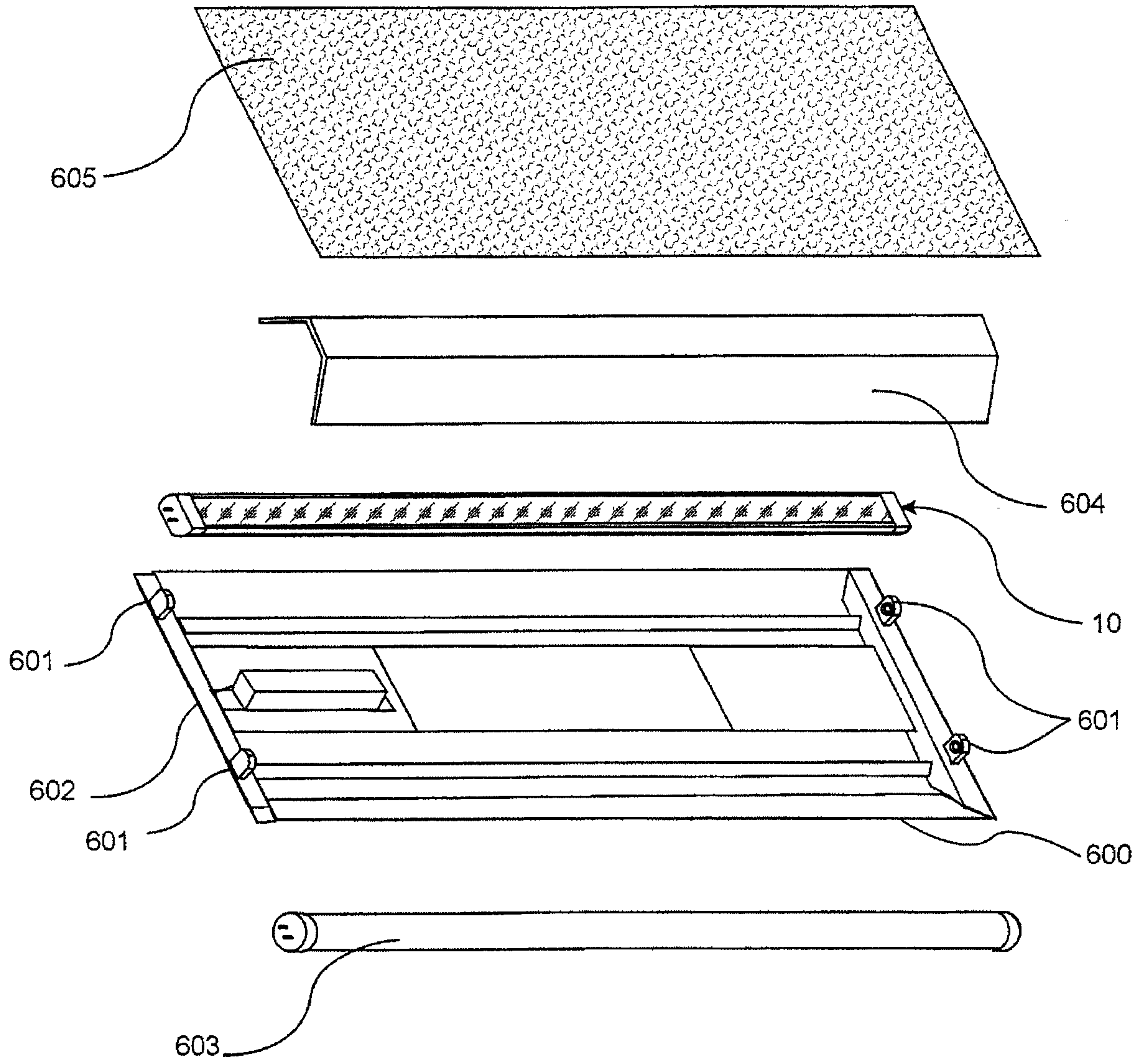

FIG. 29

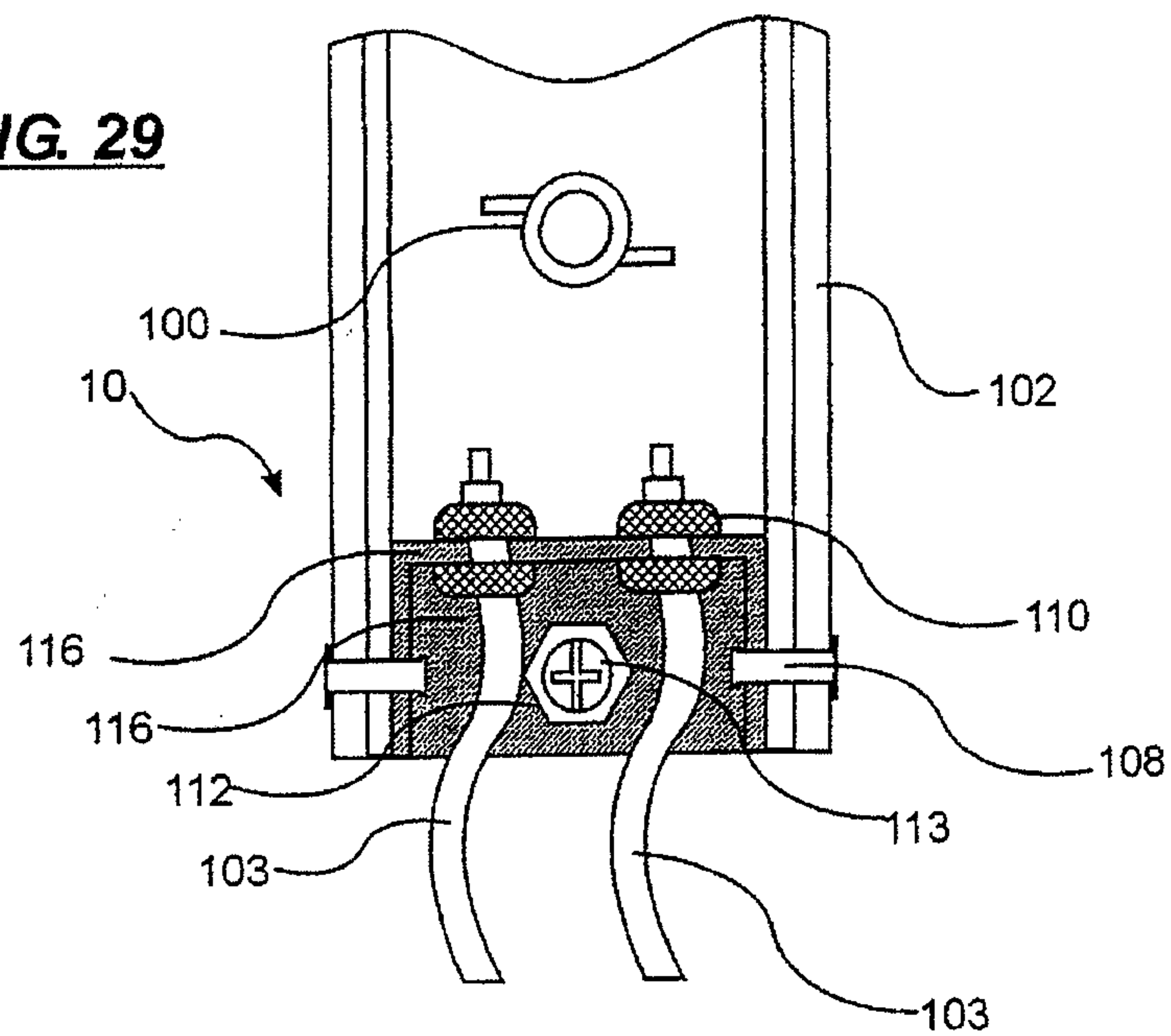

FIG. 30

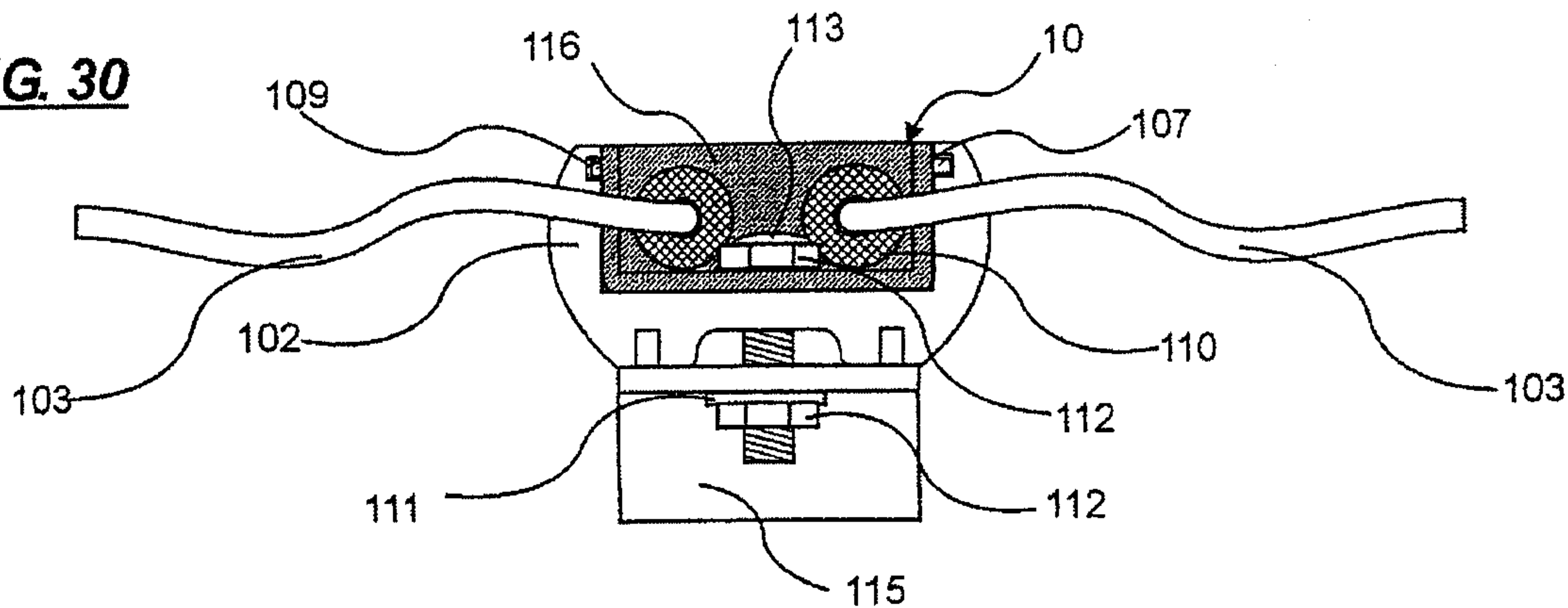

FIG. 31

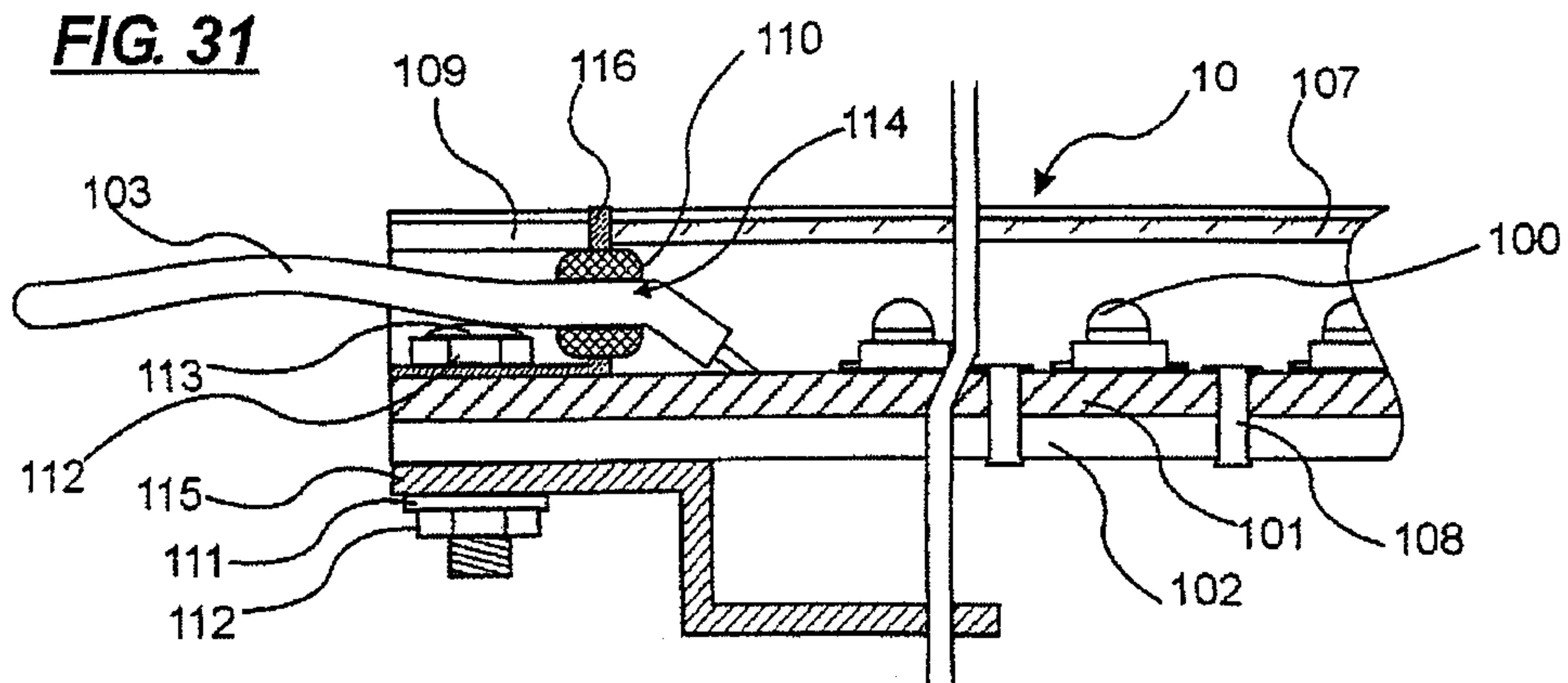

FIG. 32

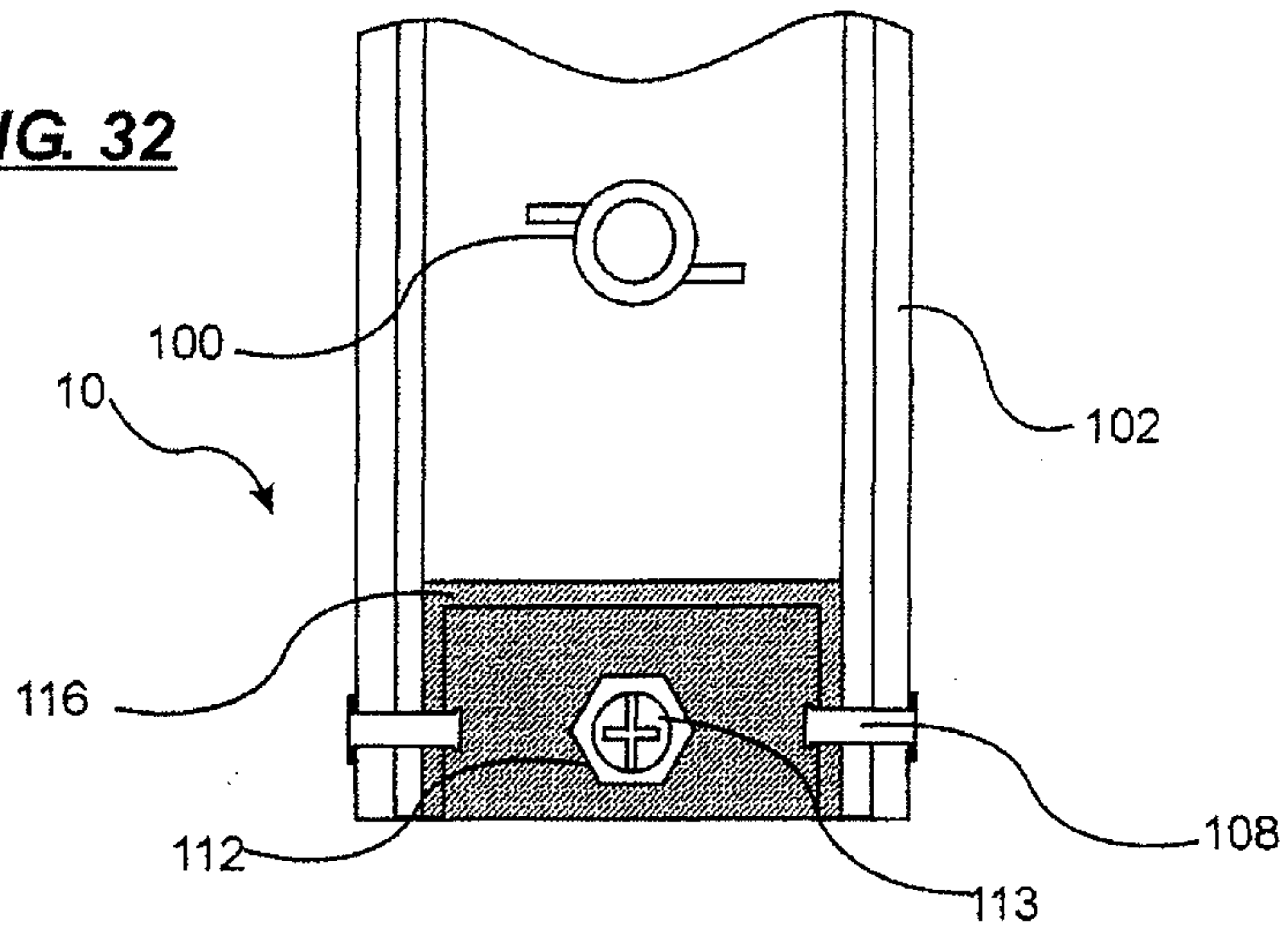

FIG. 33

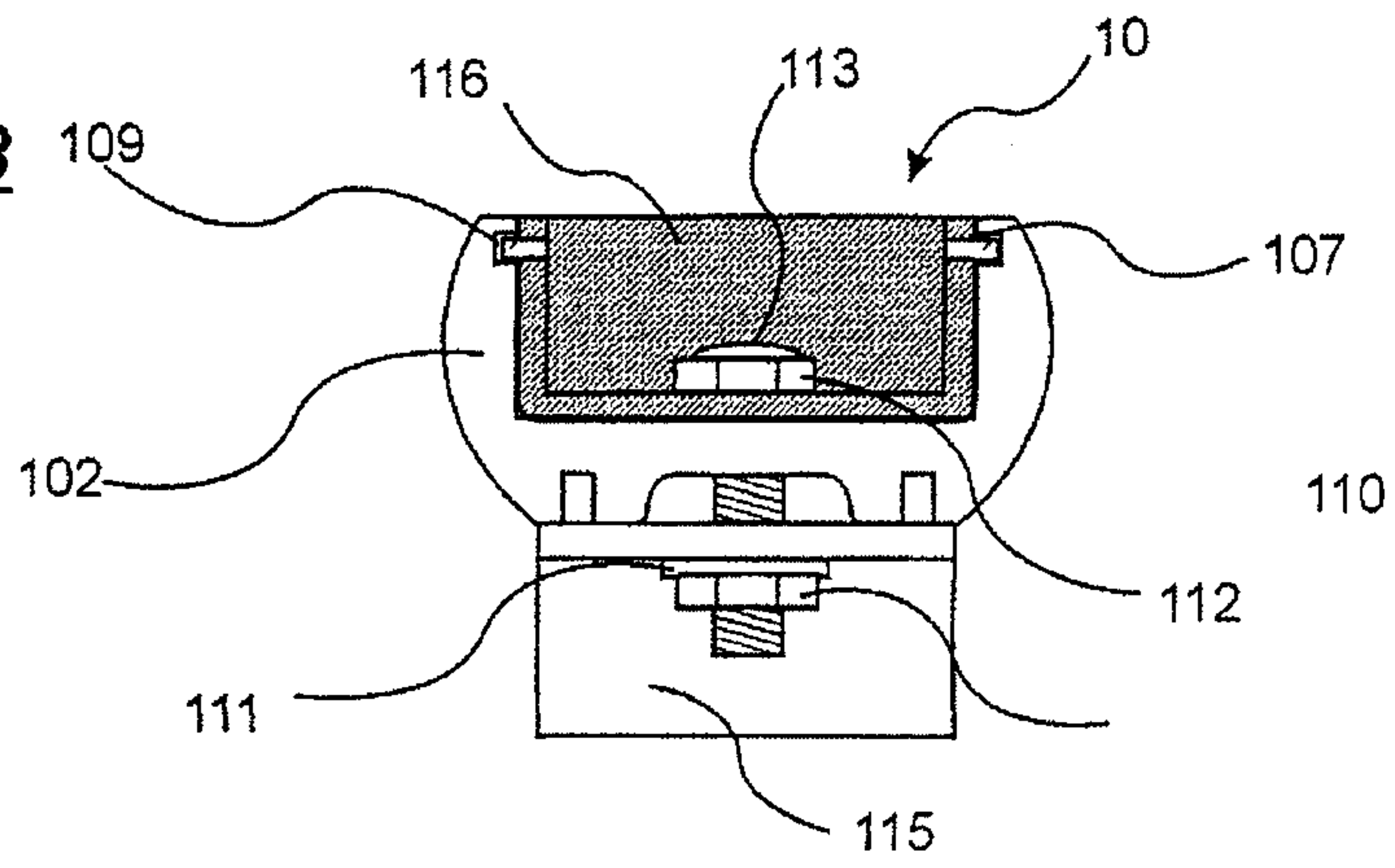

FIG. 34

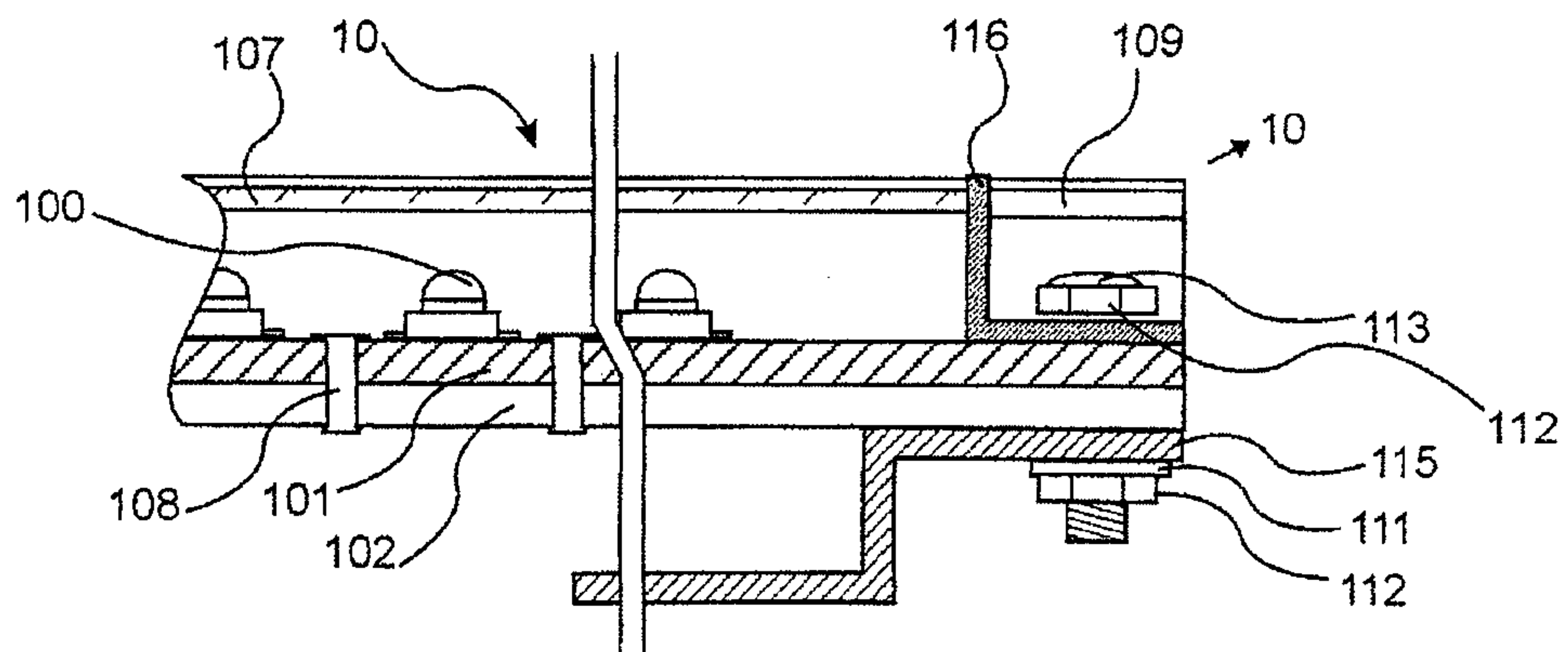
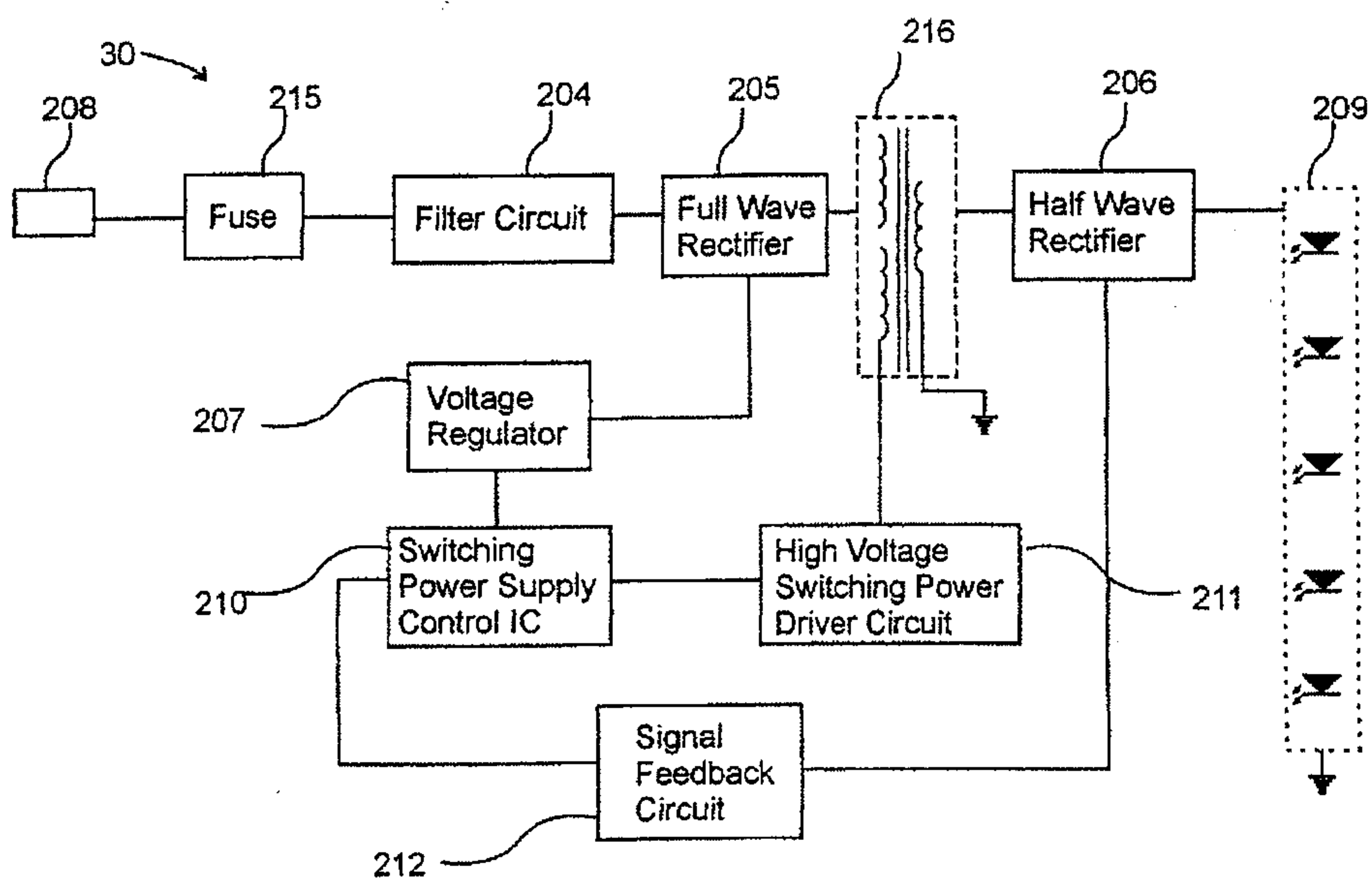

FIG. 35



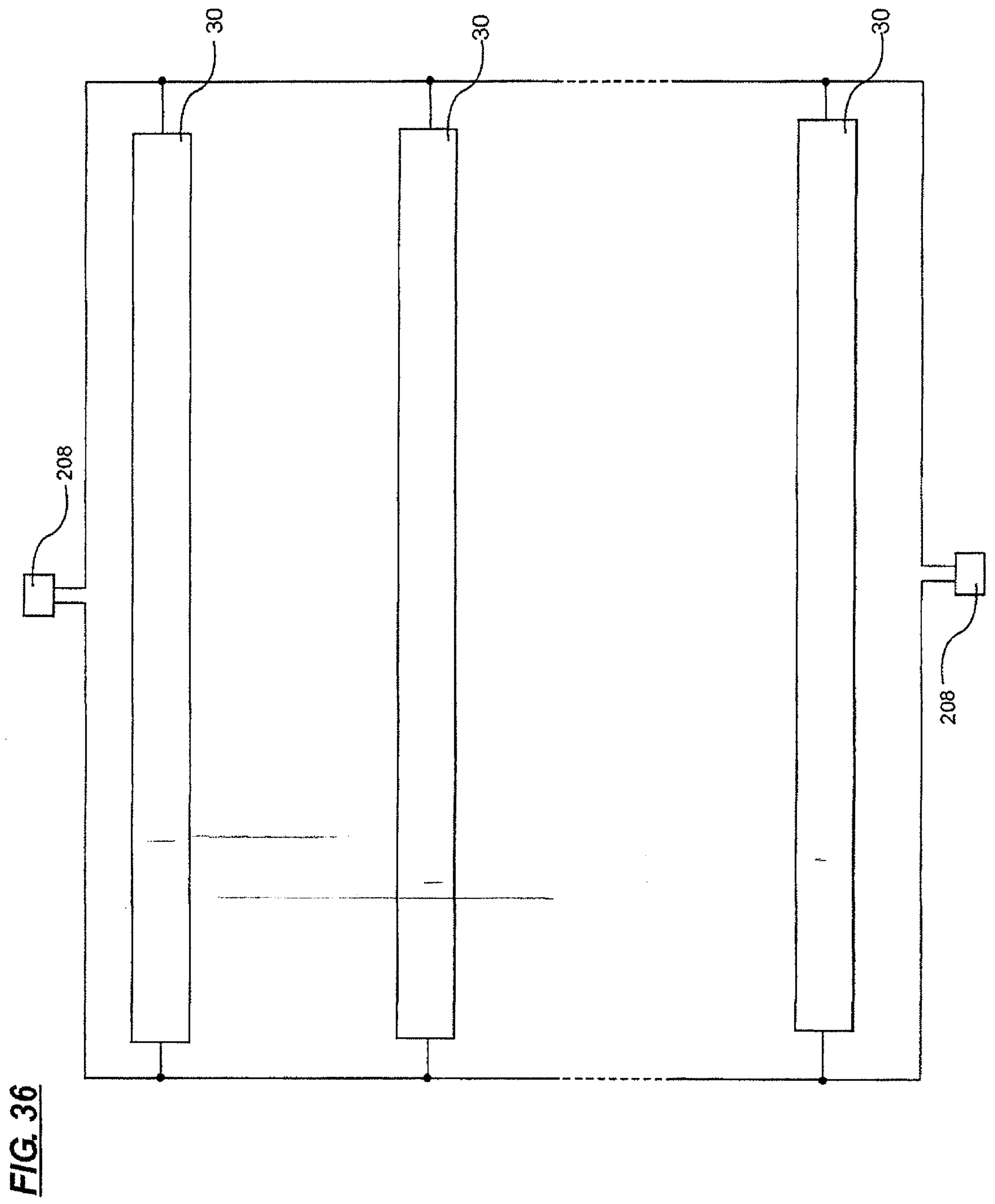

FIG. 36

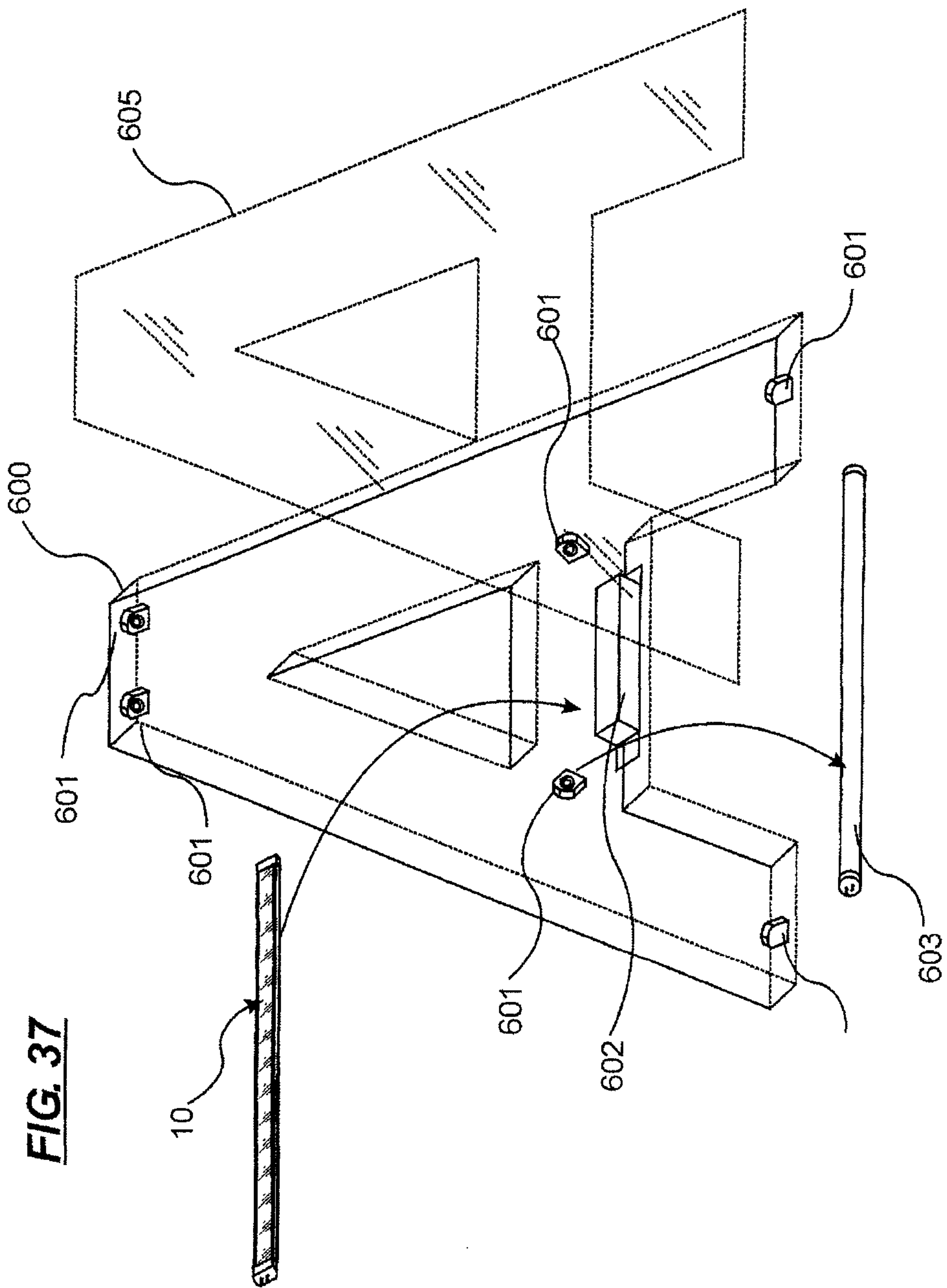

FIG. 37

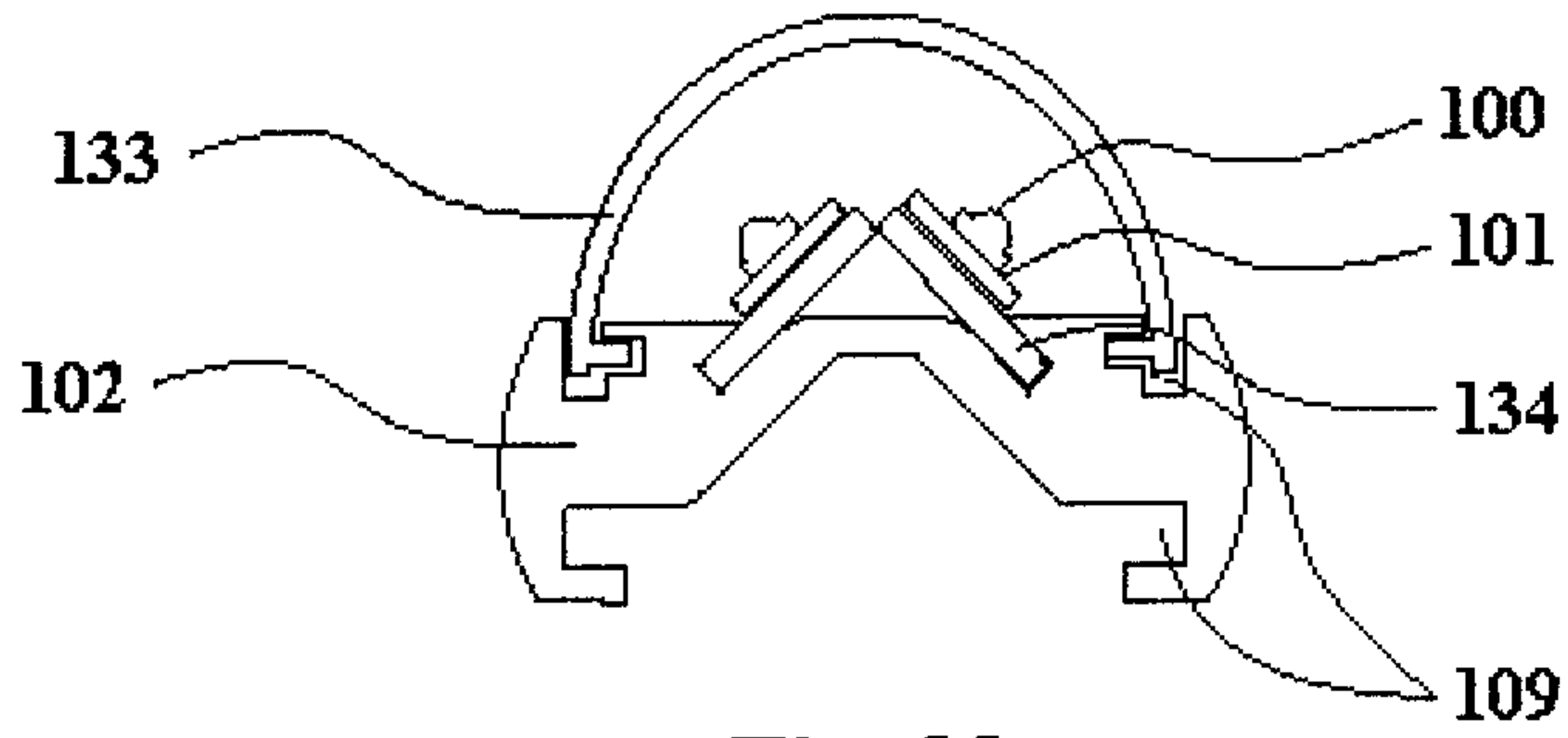

Fig. 38

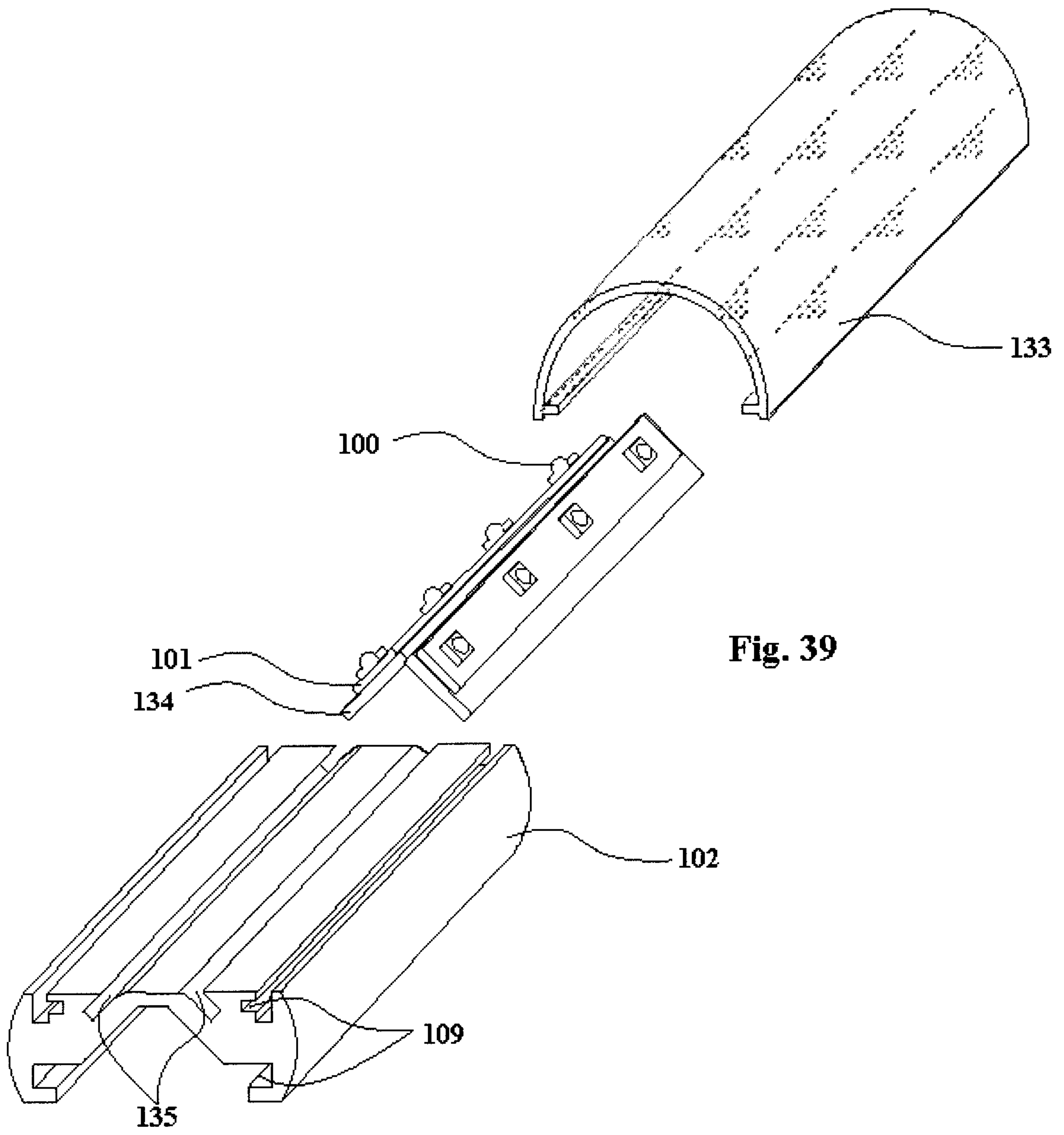

Fig. 39

