



(19) **United States**

(12) **Patent Application Publication**

Heslin et al.

(10) **Pub. No.: US 2002/0113203 A1**

(43) **Pub. Date: Aug. 22, 2002**

(54) **VEHICLE INTERIOR REARVIEW MIRROR ASSEMBLY INCLUDING AN ACCESSORY-CONTAINING HOUSING**

continuation-in-part of application No. 09/003,966, filed on Jan. 7, 1998, now Pat. No. 6,250,148.

**Publication Classification**

(75) Inventors: **Patrick Heslin**, Glasnevin (IE); **Niall R. Lynam**, Holland, MI (US)

(51) **Int. Cl.<sup>7</sup>** ..... **H01J 5/02**  
(52) **U.S. Cl.** ..... **250/239**

Correspondence Address:  
**VAN DYKE, GARDNER, LINN AND BURKHART, LLP**  
**2851 CHARLEVOIX DRIVE, S.E.**  
**P.O. BOX 888695**  
**GRAND RAPIDS, MI 49588-8695 (US)**

(57) **ABSTRACT**

A vehicle interior rearview mirror assembly comprises a housing having a front end releasably attached to the interior surface of the vehicle windshield and a rear end having a ball and socket joint for a rearview mirror unit. An internal wall subdivides the interior of the housing into first and second compartments. The first compartment contains a rain sensor which is preferably biased into contact with the windshield, and the second compartment contains a further electrical component such as a compass sensor accessible through a side opening. A removable cover mates with the housing around the opening and extends along the windshield towards the vehicle header. Electrical leads for the rain sensor and the component are routed under the cover to the header.

(73) Assignee: **Donnelly Corporation**, Holland, MI

(21) Appl. No.: **09/997,579**

(22) Filed: **Nov. 29, 2001**

**Related U.S. Application Data**

(63) Continuation of application No. 09/433,467, filed on Nov. 4, 1999, now Pat. No. 6,326,613, which is a

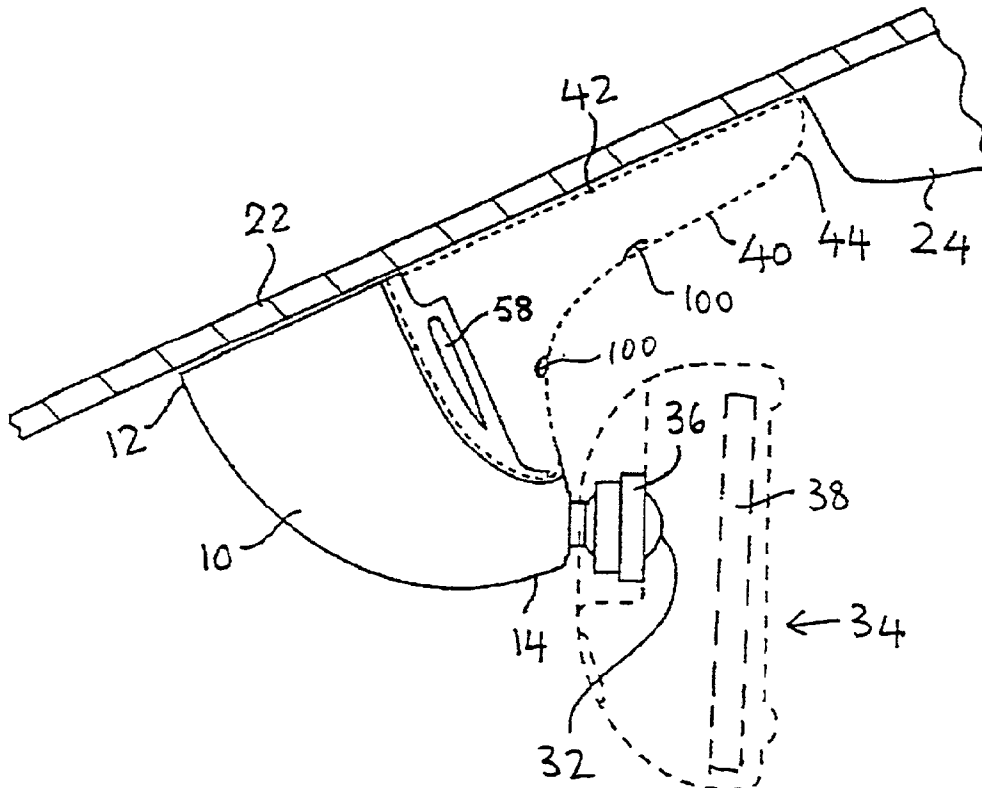

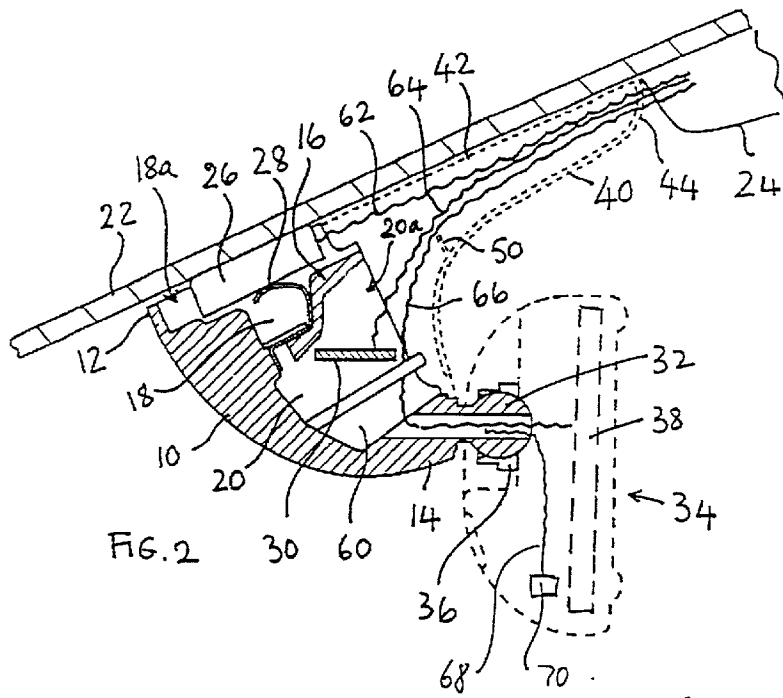

FIG. 2

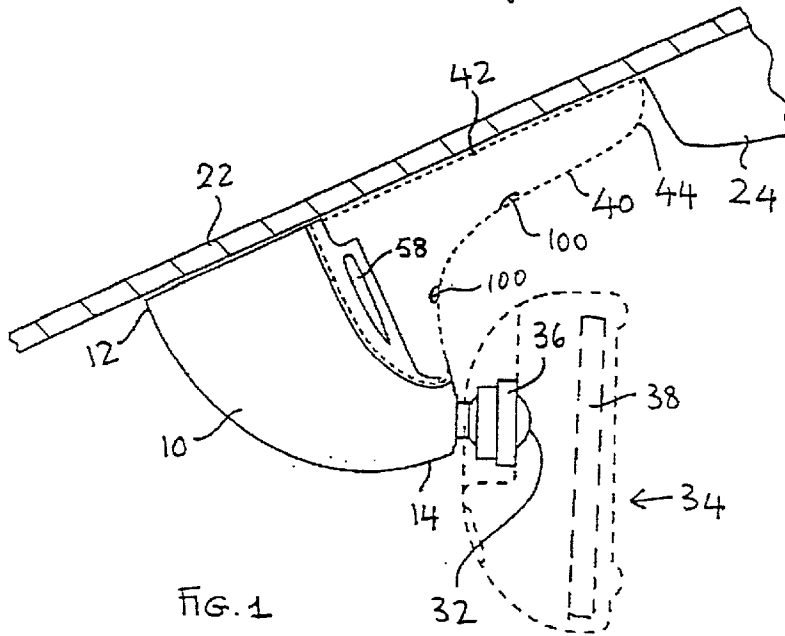

FIG. 1

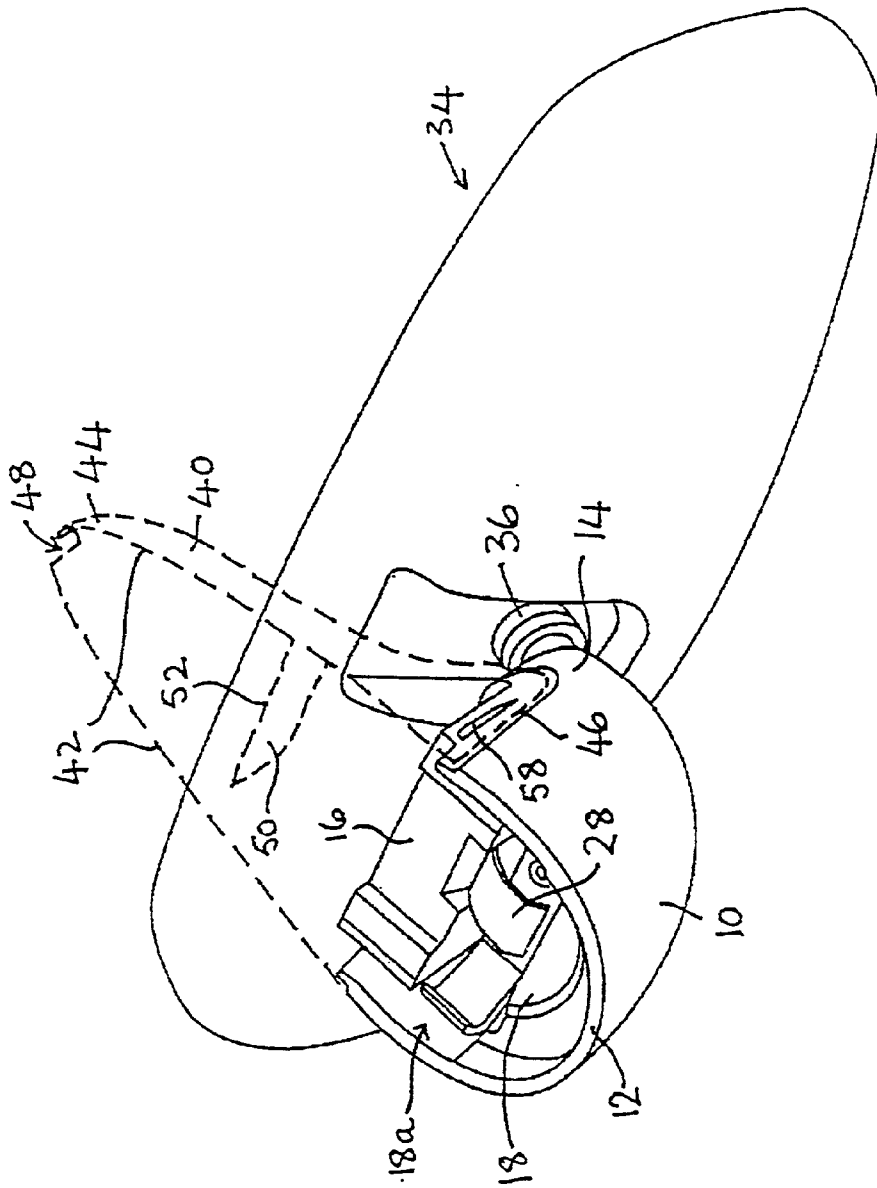

FIG. 3

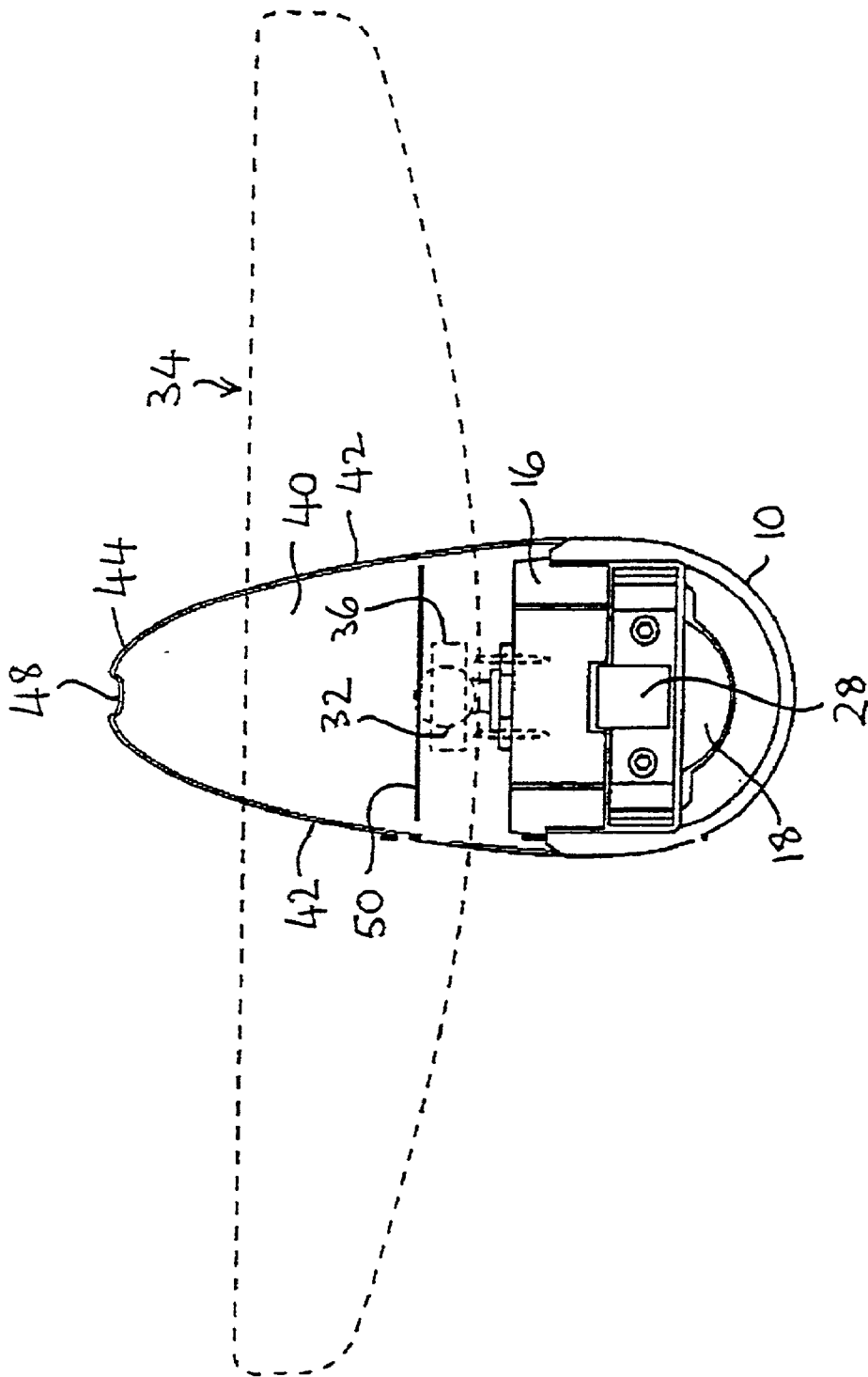
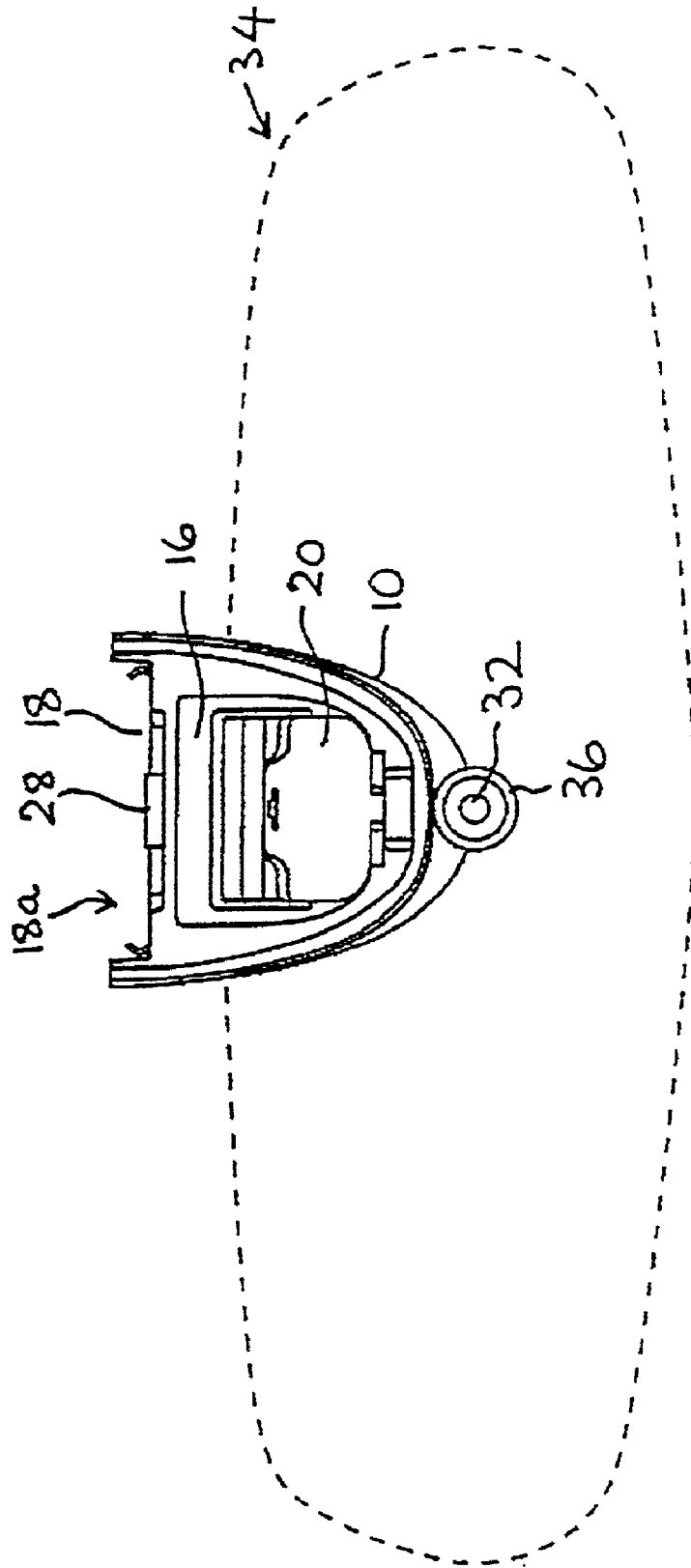

FIG. 4

FIG. 5



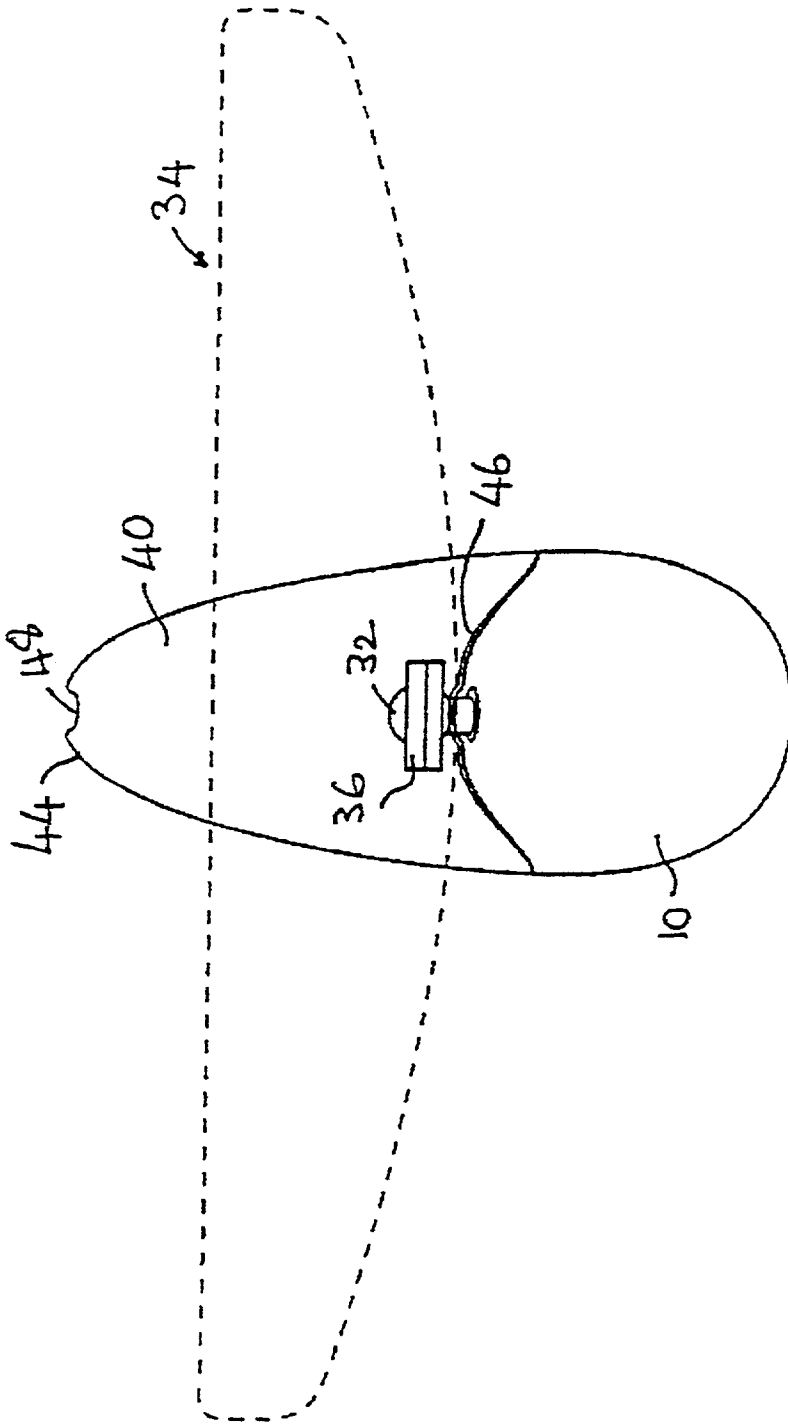

FIG. 6

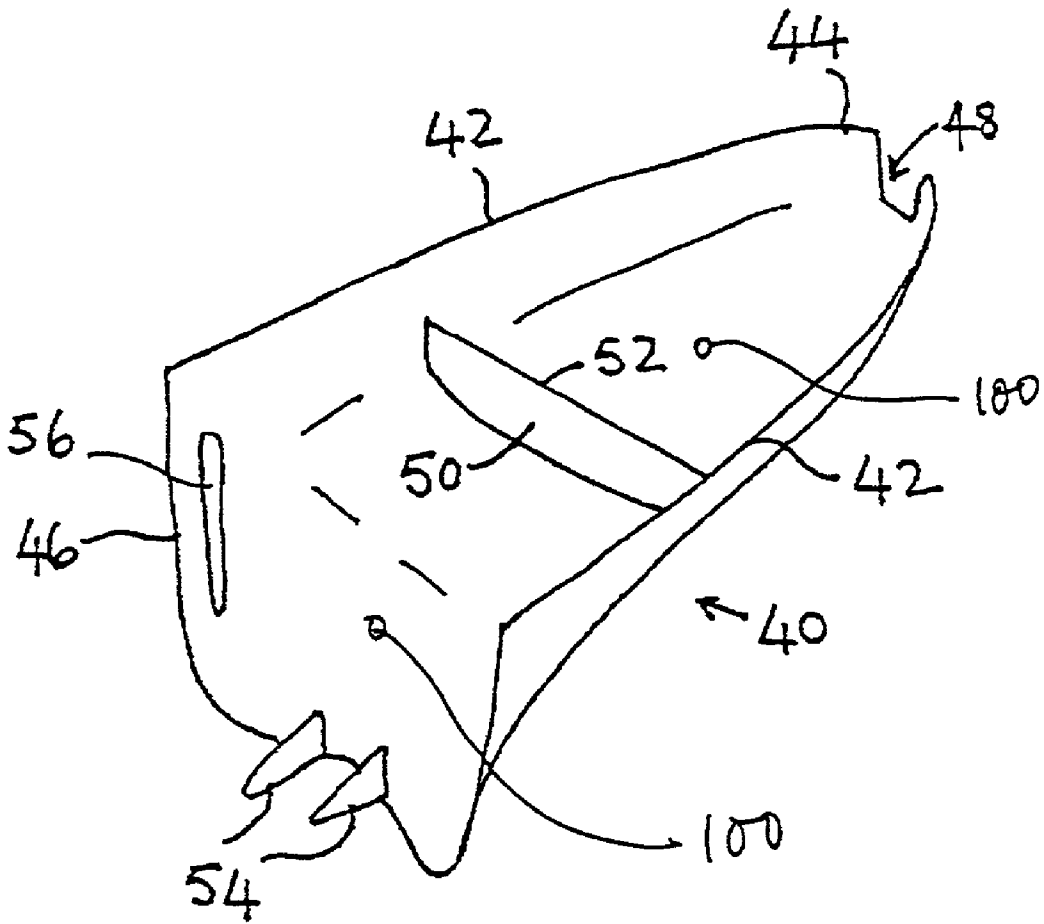

FIG. 7

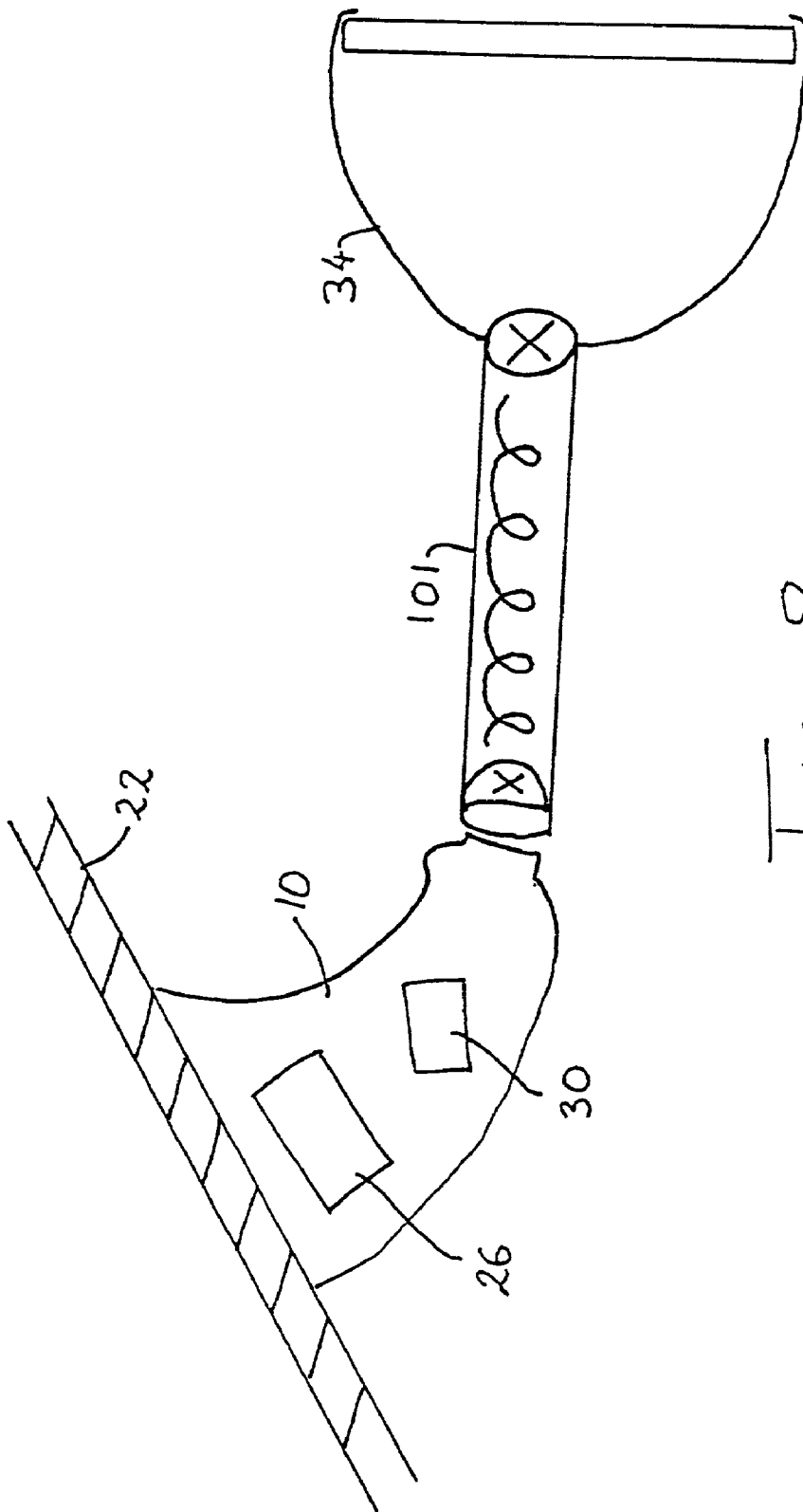

FIG. 8



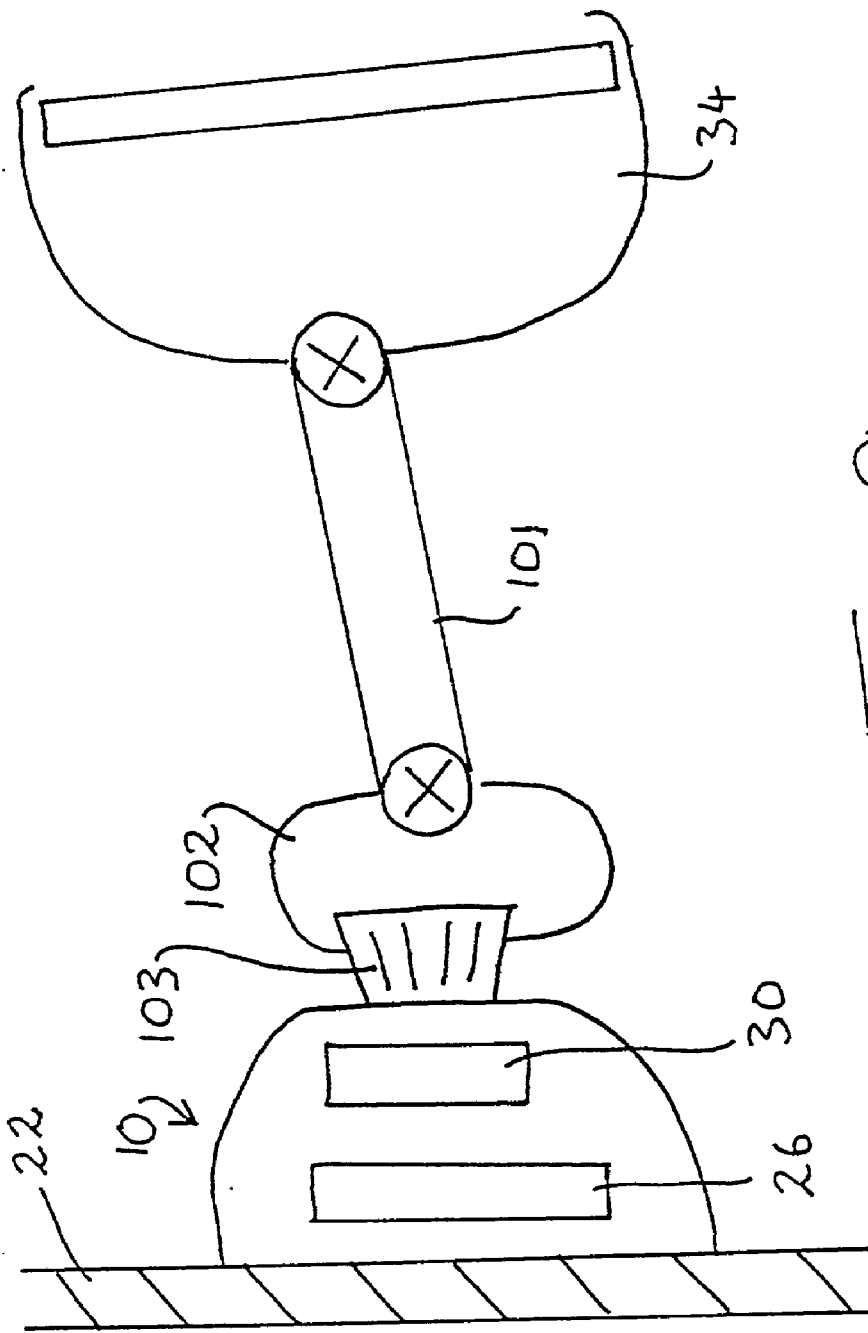

FIG. 9

**VEHICLE INTERIOR REARVIEW MIRROR  
ASSEMBLY INCLUDING AN  
ACCESSORY-CONTAINING HOUSING**

**BACKGROUND AND SUMMARY OF THE  
INVENTION**

[0001] This invention relates to a vehicle interior mirror assembly.

[0002] According to the invention there is provided a vehicle interior rearview mirror assembly comprising a housing having a front end for releasable attachment to the interior surface of the vehicle windshield, a rear end having connection means for adjustably mounting a rearview mirror unit to the housing, the housing adapted for containing a rain sensor and biasing means in use biasing the rain sensor into contact with the interior surface of the windshield, the housing containing at least one further electrical component.

[0003] The invention further provides a vehicle interior rearview mirror assembly comprising a housing having a front end for releasable attachment to the interior surface of the vehicle windshield, a rear end having connection means for adjustably mounting a rearview mirror unit to the housing, the interior of the housing comprising at least one compartment, the compartment having an opening at the front end of the housing for facing in use towards the windshield and, the compartment adapted for containing a rain sensor and for biasing the rain sensor forwardly through the first opening into contact with the interior surface of the windshield, and the housing also containing at least one further electrical component.

[0004] The invention further provides a vehicle interior rearview mirror assembly comprising a housing having a front end for releasable attachment to the interior surface of the vehicle windshield, a rear end having connection means for adjustably mounting a rearview mirror unit to the housing, the interior of the housing comprising a compartment, the compartment having a first opening at the front end of the housing for facing in use towards the windshield and the compartment having a second opening on at least one side of the housing, the compartment containing a rain sensor and means for biasing the rain sensor forwardly through the first opening into contact with the interior surface of the windshield, and the compartment containing at least one further electrical component accessible through the second opening

[0005] According to the present invention there is provided a vehicle interior rearview mirror assembly comprising a housing having a front end for releasable attachment to the interior surface of the vehicle windshield, a rear end having connection means for mounting a rearview mirror unit to the housing, and an internal wall subdividing the interior of the housing into first and second compartments, the first compartment having a first opening at the front end of the housing for facing in use towards the windshield and the second compartment having a second opening on at least one side of the housing, the first compartment containing a rain sensor and means for biasing the rain sensor forwardly through the first opening into contact with the interior surface of the windshield, and the second compartment containing at least one further electrical component accessible through the second opening.

[0006] The invention further provides a vehicle interior rearview mirror assembly comprising a housing having a

front end for releasable attachment to the interior surface of the vehicle windshield, a rear end having connection means for releasably mounting a rearview mirror unit to the housing, a first opening at the front end of the housing for facing in use towards the windshield, and a second opening on at least one side of the housing for facing in use towards the top edge of the windshield, the housing containing a rain sensor, means for biasing the rain sensor forwardly through the first opening into contact with the interior surface of the windshield, and at least one further electrical component accessible through the second opening. The assembly further preferably including a removable cover which mates with the housing around the second opening and in use preferably extends along the windshield towards the vehicle header, and electrical leads for the rain sensor and the further electrical component which in use are routed under the cover to the header.

[0007] The invention provides the significant advantage that a vehicle manufacturer is provided with the possibility of optionally including a variety of components with the rear view mirror assembly. This possibility is made available for example during the assembly line process where the desired components to meet a particular specification can be included in the rear view mirror assembly. Furthermore, the removable cover readily provides for the functional advantage of readily incorporating a selected component whilst at the same time providing a functionally attractive cover. The automaker is therefore provided with the considerable advantage of the possibility of providing a plurality of diverse options quickly and speedily during the assembly line process.

[0008] An embodiment of the invention will now be described, by way of example, with reference to the accompanying drawings, in which:

**BRIEF DESCRIPTION OF THE DRAWINGS**

[0009] **FIG. 1** is a side view of an embodiment of a vehicle interior mirror assembly according to the invention attached to the interior surface of a windshield;

[0010] **FIG. 2** is a cross-section through the mirror assembly of **FIG. 1**;

[0011] **FIG. 3** is a perspective top view of the mirror assembly;

[0012] **FIG. 4** is a view of the mirror assembly of **FIG. 3** looking into the opening **18**;

[0013] **FIG. 5** is a view of the mirror assembly of **FIG. 3** looking into the opening **20**;

[0014] **FIG. 6** is a view of the mirror assembly of **FIG. 3** looking from underneath;

[0015] **FIG. 7** is a perspective view of the wiring cover forming part of the mirror assembly;

[0016] **FIG. 8** is a schematic view of another embodiment of vehicle interior mirror assembly according to the invention; and

[0017] **FIG. 9** is a schematic view of yet a further embodiment of a vehicle interior rear mirror assembly according to the invention.

[0018] In certain of the figures some components are omitted or shown in dashed outline to reveal the underlying structure.

#### DESCRIPTION OF THE PREFERRED EMBODIMENTS

[0019] Referring to the drawings, a vehicle interior rear-view mirror assembly comprises a die cast metal housing **10** (or optionally may be formed from a plastic moulding such as engineering polymeric resin such as a filled nylon or the like) having a front end **12** and a rear end **14**, the front end **12** being releasably attached to the interior surface of the vehicle windshield **22** in a manner to be described. The interior of the housing **10** is subdivided by an internal wall **16** into first and second compartments **18**, **20** respectively, the first compartment **18** having an opening **18a** at the front end of the housing **10** which in use, and as shown in **FIGS. 1 and 2**, faces towards the windshield **22** and the second compartment having an opening **20a** on the side of the housing which in use faces towards the vehicle header **24** at the top edge of the windshield. The front end **12** of the housing **10** is releasably attached to the windshield **22** using an annular mounting button, not shown, in the manner described in EP 0 928 723 and U.S. patent application Ser. No. 09/003,966, entitled "Rain Sensor Mount for Use in a Vehicle" to Niall R Lynam, the disclosures of which are incorporated herein by reference.

[0020] The compartment **18** contains a rain sensor **26**, preferably a compact rain sensor module available from ITT Automotive Europe GmbH of Frankfurt, Germany. The compartment **18** preferably also contains an arcuate steel spring finger **28** which is secured to the base of the compartment **18** behind the rain sensor **26** and preferably serves to bias the rain sensor **26** through the aperture in the mounting button and the opening **18a** into optical contact with the windshield **22**. Most preferably, rain sensor **26** is a module which has a cross section diameter of at least 25 millimeters (mm), more preferably at least 30 mm, but with a maximum diameter  $\leq 50$  mm, more preferably  $\leq 40$  mm, and most preferably  $\leq 35$  mm.

[0021] The compartment **20** contains at least one further electrical component which is accessible through the opening **20a**. In the present embodiment the component is a printed circuit board **30** bearing a compass sensor such as a flux gate, magnetoinductive, magnetoresistive or magneto-capacitive sensor.

[0022] At its rear end **14** the housing **10** has an integral ball **32** for releasably and adjustably mounting a rearview mirror unit **34** to the housing **10** generally in conventional manner. The mirror unit **34** comprises a mirror housing **36** containing a mirror **38** which is preferably an electro-optic mirror comprising front and rear plates separated by a space which contains an electro-optic medium such as an electrochromic medium allowing variation in the amount of light transmitted through the medium by varying the strength of an electric field applied across the medium. Alternatively a prismatic mirror element can be used. Such mirrors are well known in the art. The ball **32** constitutes one part of a ball and socket joint, the socket **36** being carried by the mirror housing **36**. The mirror housing is adjustable about the ball and socket joint. Advantageously, the housing **10** is fixedly attached to the windshield when mounted thereto. Thus,

adjustment of the mirror housing to set the field of rearward view of the mirror reflective element therein does not effect the position/orientation of rain sensor and any other accessory housed in fixedly-attached housing **10**. This is particularly advantageous when the electrical accessory in housing **10** comprises a compass sensor such as a magneto-resistive sensor, a magneto-inductive sensor, a magneto-capacitive sensor or a flux-gate sensor. By having the housing **10** be fixedly attached, and by having it accommodate at least two electrical accessories (at least one of which preferably comprises a rain sensor that is mounted in the housing **10** so as to view through and preferably contact the windshield inner surface, and with the rain sensor attached to the windshield generally coaxial with the mirror unit that is adjustable about housing **10**), a compact overall interior mirror system is provided comprising a housing accommodating a plurality of electrical accessories, the housing fixedly and detachably mounted to a receiving structure on the inner surface (typically a glass surface) of the vehicle windshield and with a mirror unit comprising a mirror support arm and a mirror housing including a reflector element, the mirror support arm/mirror housing being adjustable about the fixed housing (and optionally detachable therefrom). In this manner, the housing **10** presents a minimal footprint when viewed from outside the vehicle through the vehicle windshield.

[0023] The assembly further includes a removable cover **40** which mates with the housing **10** around the opening **20a** and extends along the windshield to the vehicle header **24**. The cover **40**, which is longitudinally symmetric, is moulded from a resilient, polymeric or plastics material and comprises a pair of opposite, substantially coplanar, longitudinal side edges **42**, **FIG. 7**, which diverge from a relatively narrow rear end **44** of the cover **40** to a relative wide flared front end **46**. The flared front end **46** of the cover is open, and there is also a small opening **48** at the narrow rear end **44**. The cover **40** has an internal strengthening wall **50** whose free edge **52** is recessed below the level of the edges **42**. At its flared front end the cover **40** has a pair of forward projections **54**, and the inside surface of the cover has a pair of raised ridges **56** (only one is seen in **FIG. 7**) each extending along a respective side of the cover adjacent to the front end **46**.

[0024] The exterior surface of the housing **10** has a corresponding pair of elongated grooves or depressions **58** along each side of the opening **20a**, the exterior width of the housing across the opening **20a** being substantially the same as the interior width of the cover **40** across the grooves **58**.

[0025] The cover **40** is fitted to the housing **10** by first inserting the projections **54** into a recess **60**, **FIGS. 2 and 5**, above the opening **20a** and then rotating the cover towards the windshield until the ribs **56** snap-engage the grooves **58** (the cover **40** is sufficiently resilient to permit this) and the edges **42** of the cover come to lie flat against the interior surface of the windshield **22**, as seen in **FIGS. 1 and 2**. The cover **40** may be removed by pulling the narrow end **44** away from the windshield until the ribs **56** disengage the grooves **58** and then withdrawing the projection **54** from the recess **60**.

[0026] The cover **40** serves a dual purpose. First, it protects the compartment **20a** and hence the component **30** against the ingress of dust and other contaminants, yet it is

easily removed to allow the component **30** to be serviced or replaced, if necessary after removing the mirror unit **34**. Secondly, it provides a conduit for electrical leads **62**, **64** and **66** respectively from the rain sensor **26**, component **30** and (if fitted) the electro-optic or other electrically operated mirror **38**.

[0027] As seen in **FIG. 1**, these leads are routed under the cover **40** and through the opening **48** at the rear end **44** of the cover into the vehicle header **24** where they are connected into the vehicle electrical system.

[0028] As clearly shown in **FIG. 2**, the ball joint **32** includes a passageway or a conduit through which can pass the electrical leads connecting to a component such as a electrochromic mirror element **38** or compass display in the mirror head **34**. In particular, there is shown a lead **68** connected to a compass display **70** which displays through the mirror element. Alternatively, the display **70** can be located at other positions in the interior rear view mirror assembly, such as in a chin portion or in an eyebrow portion.

[0029] Optionally, the removable cover includes at least one opening **100** or port through which a pointed object such as the tip of a ball point pen or a needle or the like can be inserted to activate switches on a PCB located in one of the compartments. Thus, for example, the zone and/or the calibration of a compass PCB can be adjusted without the necessity to remove the removable cover.

[0030] Also, a camera may be located on the assembly for example on the housing, or mirror unit or cover and arranged to look either forwardly or rearwardly in terms of the direction of motion of the vehicle, or in another desired direction. In **FIGS. 8 and 9** there is shown schematic views of other embodiments of the invention. Thus, in **FIG. 8** there is shown the housing **10** containing a rain sensor **26** and another electrical component for example a printed circuit board of a compass sensor **30**, with the housing attached to the vehicle windshield **22**. The mirror unit **34** is adjustably attached to the housing **10** by a double ball adjustable mirror support arm **101**.

[0031] In **FIG. 9**, the mirror support arm **101** is attached to a mirror assembly mount **102**. The housing **10** also comprises a mirror assembly mount button **103** which may be fixed to the housing **10** or integrally formed therewith. The mount **102** is detachably attached to the mirror assembly mount button **103**.

[0032] Although the component **30** has been described as a compass sensor PCB, it can be any of a number of sensors or circuits which can be made small enough to fit in the compartment **20**. Preferably, component **30** is provided as a unitary module that is received within compartment **20**. Most preferably, component **30** is electrically connected with the electric/electronic wiring provided to the rear view mirror assembly. Thus, an electronic accessory can be provided as a module, can be inserted and received in the rear view mirror assembly, and can make electrical connection (such as by a plug and socket to the rear view mirror assembly). This facilitates and enables the manufacture and supply of the rear view mirror assembly, by a mirror assembly manufacturer, to a vehicle assembly line, and the separate manufacture and supply of the electrical/electronic module to that vehicle assembly line, with the automaker conveniently inserting the electric/electronic module into

the compartment of the rear view mirror assembly when the rear view mirror assembly is being mounted on a vehicle passing down a vehicle assembly line.

[0033] For example, the compartment **20** may contain a sensor or sensors for vehicle altitude and/or incline, seat occupancy or air bag activation enable/disable, or (if a viewing aperture is made in the housing **10**) photosensors for headlamp intensity/daylight intensity measurement. Alternatively, the compartment **20** may contain a transmitter and/or receiver, along with any associated sensors, for geographic positioning satellite (GPS) systems, pagers, cellular phone systems, ONSTAR™ wireless communication systems, vehicle speed governors, security systems, tire monitoring systems, remote fueling systems where vehicle fueling and/or payment/charging for fuel is remotely achieved, remote keyless entry systems, garage and/or security door opener systems, INTERNET interfaces, vehicle tracking systems, remote car door unlock systems, e-mail systems, toll booth interactions systems, highway information systems, traffic warning systems, home access systems, garage door openers and the like. Of course, any of the above may be mounted under the cover **40**, in addition to the component **30** in the compartment **20**.

[0034] Where the component **30** is a transmitter or receiver, or where a further component mounted under the cover **40** is a transmitter or receiver, the cover **40** may include an associated antenna. The antenna may mounted as a separate item under the cover **40**, or the cover itself may serve as the antenna, being either coated with a layer of conductive material or moulded from a conductive plastics material.

[0035] Also, a photosensor may be included in a compartment of the housing, preferably a skyward facing photosensor that views skyward through the vehicle windshield for the purpose of providing automatic headlamp activation/deactivation at dusk/dawn. Also, the housing may include a single microphone or a plurality of microphones for detecting vocal inputs from vehicle occupants for the purpose of cellular phone wireless communication.

[0036] Most preferably such microphones provide input to an audio system that transmits and communicates wirelessly with a remote transceiver, preferably in voice recognition mode. Such systems are described in commonly assigned, U.S. patent application Ser. No. 09/382,720, filed Aug. 25, 1999, the disclosure of which is hereby incorporated by reference herein.

[0037] In this regard it may be desirable to use audio processing techniques such as digital sound processing to ensure that vocal inputs to the vehicular audio system are clearly distinguished from cabin ambient noise such as from wind noise, HVAC, and the like.

[0038] Preferably the housing includes an analog to digital converter and or a digital analog converter for the purpose of converting the analog output of the microphone to a digital signal for input to a digital sound processor and for conversion of the digital output of a digital sound processor to an analog signal for wireless transmission to a remote transceiver.

[0039] The housing may include a variety of information displays such as a PSIR (Passenger Side Inflatable Restraint) display, an SIR (Side-Airbag Inflatable Restraint), compass/

temperature display, a tire pressure status display or other desirable displays, such as those described in commonly assigned, U.S. patent application Ser. No. 09/244,726, filed Feb. 5, 1999, the disclosure of which is hereby incorporated by reference herein.

[0040] For example, the interior rearview mirror assembly may include a display of the speed limit applicable to the location where the vehicle is travelling. Conventionally, speed limits are posted as a fixed limit (for example, 45 MPH) that is read by the vehicle driver upon passing a sign. As an improvement to this, an information display (preferably an alphanumeric display and more preferably, a reconfigurable display) can be provided within the vehicle cabin, readable by the driver, that displays the speed limit at whatever location on the road/highway the vehicle actually is at any moment. For example, existing speed limit signs could be enhanced to include a transmitter that broadcasts a local speed limit signal, such signal being received by an in-vehicle receiver and displayed to the driver. The speed limit signal can be transmitted by a variety of wireless transmission methods, such as radio transmission, and such systems can benefit from wireless transmission protocols and standards, such as the BLUETOOTH low-cost, low-power radio based cable replacement or wireless link based on short-range radio-based technology. Preferably, the in-vehicle receiver is located at and/or the display of local speed limit is displayed at the interior mirror assembly (for example, a speed limit display can be located in a chin or eyebrow portion of the mirror case, such as in the mirror reflector itself, such as in the cover 40, or such as in a pod attached to the interior mirror assembly). More preferably, the actual speed of the vehicle can be displayed simultaneously with and beside the local speed limit in-vehicle display and/or the difference or excess thereto can be displayed. Optionally, the wireless-based speed limit transmission system can actually control the speed at which a subject vehicle travels in a certain location (such as by controlling an engine governor or the like). Thus, a school zone speed limit can be enforced by transmission of a speed-limiting signal into the vehicle. Likewise, different speed limits for the same stretch of highway can be set for different classes of vehicles. The system may also require driver identification and then set individual speed limits for individual drivers reflecting their skill level, age, driving record and the like. Moreover, a global positioning system (GPS) can be used to locate a specific vehicle, calculate its velocity on the highway, verify what the allowed speed limit is at that specific moment on that specific stretch of highway, transmit that specific speed limit to the vehicle for display (preferably at the interior rearview mirror that the driver constantly looks at as part of the driving task) and optionally alert the driver or retard the driver's ability to exceed the speed limit as deemed appropriate. A short-range, local communication system such as envisaged in the BLUETOOTH protocol finds broad utility in vehicular applications, and particularly where information is to be displayed at the interior mirror assembly, or where a microphone or user-interface (such as buttons to connect/interact with a remote wireless receiver) is to be located at the interior (or exterior) rearview mirror assembly. For example, a train approaching a railway crossing may transmit a wireless signal such as a radio signal (using the BLUETOOTH protocol or another protocol) and that signal may be received by and/or displayed at the interior rearview mirror assembly (or the exterior sideview

mirror assembly). Also, the interior rearview mirror and/or the exterior side view mirrors can function as transceivers/display locations/interface locations for intelligent vehicle highway systems, using protocols such as the BLUETOOTH protocol. Protocols such as BLUETOOTH, as known in the telecommunications art, can facilitate voice/data, voice over data, digital and analogue communication and vehicle/external wireless connectivity, preferably using the interior and/or exterior mirror assemblies as transceiver/display/user-interaction sites. Electronic accessories to achieve the above can be accommodated in housing 10, and/or elsewhere in the interior mirror assembly (such as in the mirror housing). Examples of such electronic accessories include in-vehicle computers, personal organizers/palm computers such as the Palm Pilot™ personal display accessory (PDA), cellular phones and pagers, remote transaction interfaces/systems such as described in commonly assigned, U.S. patent application Ser. No. 09/057,428, filed Apr. 8, 1999, the disclosure of which is hereby incorporated by reference herein, automatic toll booth payment systems, GPS systems, e-mail receivers/displays, a videophone, vehicle security systems, digital radio station transmission to the vehicle by wireless communication as an alternate to having an in-vehicle dedicated conventional radio receiver, traffic/weather broadcast to the vehicle, preferably digitally, and audio play and/or video display thereof in the vehicle, most preferably at the interior rearview mirror, highway hazard warning systems and the like.

[0041] The information display at the interior rearview mirror assembly (such as at the mirror housing or viewable in the mirror reflector) may be formed using electronic ink technology and can be reconfigurable. Examples of electronic ink technology include small plastic capsules or microcapsules, typically  $\frac{1}{10}$  of a millimeter across or thereabouts, that are filled with a dark ink and that have in that ink white particles which carry a charge such as a positive charge. Electrodes place an electric field across the capsules and the electric field can attract or repel the charged particles in the capsules. If the white particle is attracted to the top of a capsule so that it is closest to a viewer, the display element/pixel appears white to the viewer. If the white particle is attracted to the bottom of the capsule (away from the viewer), the display element/pixel appears dark as the viewer now sees the dark ink in the capsule. Such displays are available from E Ink of Cambridge, Mass. Such electronic ink displays have the advantage of forming text or graphics that, once formed, do not disappear when the display powering voltage is disconnected (i.e. they have a long display memory). Alternately, GYRICON™ electronic ink technology developed by XEROX Corporation can be used. Here, microbeads are used that are black (or another dark color) on one side and white (or another light color) on the other side. The beads are dipolar in that one hemisphere carries a stronger (and hence different) charge than the opposing other hemisphere. The beads are small (about  $\frac{1}{10}$ th of a millimeter diameter) and turn or flip when placed in an electric field, with the respective poles of the dipolar beads being attracted to the corresponding polarity of the applied electric field. Thus, a white pixel or a black pixel can be electrically written. Once the bead has turned or flipped, it remains turned or flipped unless an electric potential of the opposite polarity is applied. Thus, the display has memory.

[0042] Other types of information displays can be used at the interior mirror location. For example, a field-emission

display such as the field-emission display available from Candescant Technologies of San Jose, Calif. can be used. Field-emission displays include a plurality of charge emitting sources or guns that bombard a phosphor screen. For example, a myriad of small or microscopic cones (<1 micron tall, for example and made of a metal such as molybdenum) are placed about a millimeter from phosphors on a screen. The cones emit electrons from their tips or apexes to bombard the phosphors under an applied electric field. This technology is adaptable to provide thin display screens (such as less than 10 mm or so). Alternately, field-emission displays can be made using carbon nanotubes which are cylindrical versions of buckminsterfullerene, and available from Motorola. Such field-emission displays are particularly useful for video displays as they have high brightness and good contrast ratio, even under high ambient lighting conditions such as in a vehicle cabin by day. Such displays can be located at the interior rearview mirror, preferably, or optionally elsewhere in the vehicle cabin such as in the dash, in the windshield header at the top interior edge of the windshield, in a seat back, or the like.

[0043] A further advantage of providing a housing **10** which accommodates multiple electrical accessories, preferably in individual compartments, is that incorporation of optional accessories into a specific vehicle is facilitated. It also facilitates supply of the housing **10** and associated mirror unit by a mirror manufacturer and supply of at least one of the electrical accessories by a second, different accessory manufacturer, and with the automaker placing the at least one electrical accessory into the housing **10** at the vehicle assembly plant, preferably at the vehicle assembly line. Thus, for example, an interior mirror assembly can be manufactured by a mirror supplier that includes housing **10**, compartments **18** and **20** (or, optionally, more compartments), printed circuit board **30** (such as a compass sensor printed circuit board) in compartment **20** but with compartment **18** empty, removable cover **40**, a mirror support arm articulating about housing **20**, a mirror housing or case supported on said support arm, a reflector element in said mirror housing (preferably an electrochromic mirror element which includes an information display such as of compass direction and /or temperature displaying through said mirror element as is known in the mirror arts). A rain sensor module can be made by a separate manufacturer. The rain sensor module and the interior mirror assembly can be shipped to a vehicle assembly plant (or local to it). Then, when a particular vehicle requires a rains sensor module, the vehicle manufacturer can place the rain sensor module into compartment **18**, connect the rain sensor module to the wire harness provided to mirror assembly (preferably, the rain sensor module docks into compartment **18** in a manner that connects it electrically to the vehicle or alternatively, the rain sensor module includes a plug or socket that connects to a corresponding socket or plug already provided in housing **10** (or elsewhere on the interior mirror assembly). This allows "plug & play" accommodation of multiple accessories into the interior rearview mirror assembly. Also, the interior rearview mirror assembly may be shipped to the assembly plant with both compartments **18** and **20** empty, thus allowing, for example, the automaker to solely place a rain sensor module into compartment **18** but add no further accessory into compartment **20**.

[0044] The invention is not limited to the embodiments described herein which may be modified or varied without departing from the scope of the invention.

1. A vehicle interior rearview mirror assembly comprising a housing having a front end for releasable attachment to the interior surface of the vehicle windshield, a rear end having a connection which adjustably mounts a rearview mirror unit to the housing, the housing adapted to contain a rain sensor and a biasing member which engages and biases the rain sensor into contact with the interior surface of the windshield, the housing containing at least one further electrical component.

2. A vehicle interior rearview mirror assembly comprising a housing having a front end for releasable attachment to the interior surface of the vehicle windshield, a rear end having a connection which adjustably mounts a rearview mirror unit to the housing, the interior of the housing comprising at least one compartment, the compartment having an opening at the front end of the housing for facing in use towards the windshield and, the compartment adapted to contain a rain sensor and to bias the rain sensor forwardly through the first opening into contact with the interior surface of the windshield, and the housing also containing at least one further electrical component.

3. A vehicle interior rearview mirror assembly comprising a housing having a front end for releasable attachment to the interior surface of the vehicle windshield, a rear end having a connection which adjustably mounts a rearview mirror unit to the housing, the interior of the housing comprising a compartment, the compartment having a first opening at the front end of the housing for facing in use towards the windshield and a second opening on at least one side of the housing, the compartment containing a rain sensor and a biasing member which biases the rain sensor forwardly through said first opening into contact with the interior surface of the windshield, and the compartment containing at least one further electrical component accessible through said second opening.

4. A vehicle interior rearview mirror assembly comprising a housing having a front end for releasable attachment to the interior surface of the vehicle windshield, a rear end having a connection which adjustably mounts a rearview mirror unit to the housing, and an internal wall subdividing the interior of the housing into first and second compartments, said first compartment having a first opening at said front end of said housing for facing in use towards the windshield and said second compartment having a second opening on at least one side of said housing, said first compartment containing a rain sensor, and said second compartment containing at least one further electrical component accessible through said second opening.

5. An assembly as claimed in claim 4, further including a removable cover which mates with said housing around said second opening and in use extends along the windshield towards the vehicle header, and electrical leads for said rain sensor and said further electrical component which in use are routed under the cover to the header.

6. An assembly as claimed in claim 5, wherein said cover is made of a polymeric material which snap-engages said housing around said second opening.

7. An assembly as claimed in claim 5, wherein said cover includes an antenna.

8. An assembly as claimed in claim 5, further including a rearview mirror unit which includes an electrically operated

rearview mirror and electrical leads for said mirror, said leads when in use being routed under said cover to the vehicle header.

**9.** An assembly as claimed in claim 4, wherein said further electrical component comprises a printed circuit board bearing a compass sensor.

**10.** An assembly as claimed in claim 4 further including a biasing member which biases said rain sensor forwardly through said first opening into contact with the interior surface of the windshield.

**11.** A vehicle interior rearview mirror assembly comprising a housing having a front end for releasable attachment to the interior surface of the vehicle windshield, a rear end having a connection which adjustably mounts a rearview mirror unit to the housing, a first opening at said front end of said housing for facing in use towards the windshield, and

a second opening on at least one side of said housing for facing in use towards the top edge of the windshield, said housing containing a rain sensor, and at least one further electrical component accessible through said second opening, said assembly further including a removable cover which mates with said housing around said second opening and in use extends along the windshield towards the vehicle header, and electrical leads for said rain sensor and said further electrical component which in use are routed under said cover to the vehicle header.

**12.** An assembly as claimed in claim 11 further including a biasing member which biases said rain sensor forwardly through said first opening into contact with the interior surface of the windshield.

\* \* \* \* \*