



<p>(51) International Patent Classification <sup>6</sup> : <b>F16F 15/22 // B63H 21/30</b></p>	<p><b>A1</b></p>	<p>(11) International Publication Number: <b>WO 96/06290</b> (43) International Publication Date: 29 February 1996 (29.02.96)</p>
<p>(21) International Application Number: PCT/DK95/00340 (22) International Filing Date: 22 August 1995 (22.08.95) (30) Priority Data: 0978/94 24 August 1994 (24.08.94) DK (71) Applicant (for all designated States except US): F.L. SMIDTH &amp; CO. A/S [DK/DK]; Vigerslev Allé 77, DK-2500 Valby (DK). (72) Inventor; and (75) Inventor/Applicant (for US only): MADSEN, John, Gram [DK/DK]; Sortedam Dossering 41C, 2. tv., DK-2200 Copenhagen N (DK). (74) Agent: CHAS. HUDE; H.C. Andersens Boulevard 33, DK-1553 Copenhagen V (DK).</p>	<p>(81) Designated States: AM, AT, AU, BB, BG, BR, BY, CA, CH, CN, CZ, DE, DK, EE, ES, FI, GB, GE, HU, IS, JP, KE, KG, KP, KR, KZ, LK, LR, LT, LU, LV, MD, MG, MK, MN, MW, MX, NO, NZ, PL, PT, RO, RU, SD, SE, SG, SI, SK, TJ, TM, TT, UA, UG, US, UZ, VN, European patent (AT, BE, CH, DE, DK, ES, FR, GB, GR, IE, IT, LU, MC, NL, PT, SE), OAPI patent (BF, BJ, CF, CG, CI, CM, GA, GN, ML, MR, NE, SN, TD, TG), ARIPO patent (KE, MW, SD, SZ, UG).  <b>Published</b> <i>With international search report. In English translation (filed in Danish).</i></p>	

(54) Title: VIBRATION-COMPENSATING APPARATUS

(57) Abstract

A vibration-compensating apparatus for counteracting harmonic vibrations from an excitation source comprises a first compensator unit with two rotary bodies (22, 23) rotating in opposite directions by the same rpm so as to generate a harmonically varying first force component in one direction. The apparatus comprises furthermore a second compensator unit with two rotary bodies (24, 25) rotating in opposite directions about axes parallel to the axes of the first compensator unit so as to generate a second harmonically varying force component in a direction parallel to the first harmonically varying force component. The rotary bodies of the first compensator unit and the rotary bodies (24, 25) of the second compensator unit are driven by separate infinitely variable driving motors (29, 30). A control and synchronizing device controls the driving motors (29, 30) of the compensator units so that the rotary bodies rotate at an rpm which is a multiple of the frequency of the excitation source.

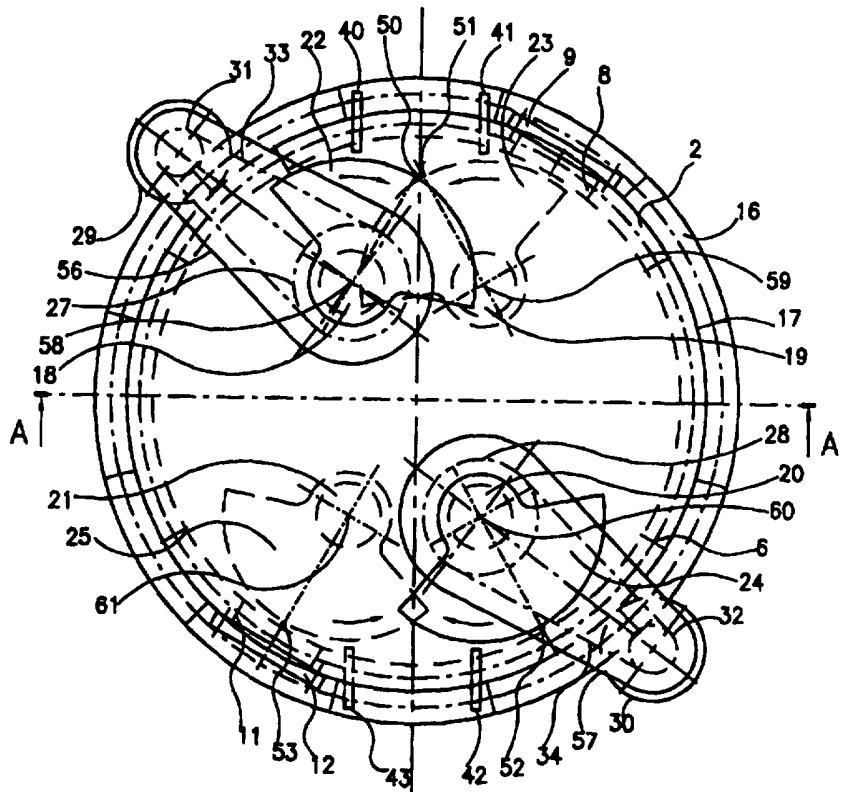

**FOR THE PURPOSES OF INFORMATION ONLY**

Codes used to identify States party to the PCT on the front pages of pamphlets publishing international applications under the PCT.

AT	Austria	GB	United Kingdom	MR	Mauritania
AU	Australia	GE	Georgia	MW	Malawi
BB	Barbados	GN	Guinea	NE	Niger
BE	Belgium	GR	Greece	NL	Netherlands
BF	Burkina Faso	HU	Hungary	NO	Norway
BG	Bulgaria	IE	Ireland	NZ	New Zealand
BJ	Benin	IT	Italy	PL	Poland
BR	Brazil	JP	Japan	PT	Portugal
BY	Belarus	KE	Kenya	RO	Romania
CA	Canada	KG	Kyrgystan	RU	Russian Federation
CF	Central African Republic	KP	Democratic People's Republic of Korea	SD	Sudan
CG	Congo	KR	Republic of Korea	SE	Sweden
CH	Switzerland	KZ	Kazakhstan	SI	Slovenia
CI	Côte d'Ivoire	LI	Liechtenstein	SK	Slovakia
CM	Cameroon	LK	Sri Lanka	SN	Senegal
CN	China	LU	Luxembourg	TD	Chad
CS	Czechoslovakia	LV	Latvia	TG	Togo
CZ	Czech Republic	MC	Monaco	TJ	Tajikistan
DE	Germany	MD	Republic of Moldova	TT	Trinidad and Tobago
DK	Denmark	MG	Madagascar	UA	Ukraine
ES	Spain	ML	Mali	US	United States of America
FI	Finland	MN	Mongolia	UZ	Uzbekistan
FR	France			VN	Viet Nam
GA	Gabon				

Title: Vibration-Compensating Apparatus

Technical Field

The invention relates to a vibration-compensating apparatus for counteracting harmonic vibrations from an excitation source, such as vibrations  
5 generated by an engine of a vessel, said vibration-compensating apparatus comprising a first compensator unit with two rotary bodies with the same eccentric mass and rotating at the same rpm in opposite direction about mutually parallel axes so as to generate a harmonically varying force component in one direction, and a second compensator unit also provided with  
10 two rotary bodies with the same eccentric mass, which rotate at the same rpm as the rotary bodies of the first compensator unit in opposite directions about parallel axes parallel with the axes of the first compensator unit so as to generate a second harmonically varying force component in a direction parallel to the direction of the first harmonically varying force  
15 component.

Background Art

DK-B1-169,848 discloses a vibration-compensating apparatus comprising two rotary bodies rotatably journalled about parallel axes and with the same eccentric mass, and which through a transmission are interconnected  
20 so as to rotate in opposite directions at the same rpm and thereby to generate a harmonically varying force component in one direction. Each rotary body comprises a rotary body part fixedly mounted on a shaft, as well as a rotary body part releasably mounted on said shaft so as to be released for rotation. A change of the harmonically oscillating force component is carried out by turning the fixed and releasable rotary body parts  
25 of each rotary body relative to one another which requires that the compensating apparatus is stopped.

DE-C-292,711 discloses a vibration-compensating apparatus of the above type for compensating for the mass forces of a piston engine. The compensator units are connected to their respective end of the main shaft of the piston engine by means of a bevel gear transmission. In order to allow  
5 a change of the resulting harmonically oscillating force generated by the compensator, it is necessary to stop the compensator and consequently also the piston engine and replace the rotary bodies or change the phase difference between the force components of the two compensator units.

#### Brief Description of the Invention

10 The object of the invention is to provide a vibration-compensating apparatus of the above type which allows a change of the resulting oscillating force component while said vibration-compensating apparatus is running.

In satisfaction of the above object the vibration-compensating apparatus according to the invention is characterised in that the rotary bodies of the  
15 first compensator unit are driven by means of at least one first infinitely variable driving motor, that the rotary bodies of the second compensator unit are driven by means of at least one second infinitely variable driving motor, and that the vibration-compensating apparatus furthermore comprises a control and synchronizing device for controlling the driving motors of  
20 the compensator units in such a manner that the rotary bodies rotate at an rpm which is a multiple of the frequency of the excitation source.

As a result, by changing the phase difference between the harmonically varying force component of the two compensator units, it is possible in an infinitely variable manner to vary the total harmonic force component of  
25 the vibration-compensating apparatus between the sum of the force component of the two compensator units and the difference therebetween while said apparatus is running. As a result, it is possible while the apparatus is running to adjust the compensation to the vibration conditions apply-

ing during changing operational conditions, such as changes in the cargo and speed of a ship as well as the weather conditions and the water depth. Furthermore, it is possible to use only one of the two compensator units, thereby achieving a reduced power consumption or providing an  
5 additional security in case one of the compensator units stops working. In addition, the use of two small compensator units, each being driven by at least one motor, results in a reduction of the necessary starting moment relative to the use of a single large compensator. The latter is of particular importance in connection with a compensator with rotary bodies which  
10 rotate in a vertical plane with the result that the eccentric masses thereof must be elevated in connection with the starting procedure and during the running of the compensator.

According to the invention, the rotary bodies of the first compensator unit may be driven by a single first driving motor and be interconnected by  
15 means of a first transmission so as to rotate in opposite directions, and the rotary bodies of the second compensator unit may be driven by a single second driving motor and be interconnected by means of a second transmission so as to rotate in opposite directions.

Moreover, according to the invention, the transmission between the two  
20 rotary bodies of each compensator unit may comprise a releasable connection allowing a turning of the two rotary bodies relative to one another so as to change their position relative to one another. A change of the relative position of the two rotary bodies of each compensator unit causes a change of the direction of the oscillating harmonic force component. Thus, it is  
25 possible to change the direction of the resulting harmonic force component without turning the entire vibration-compensating apparatus.

Furthermore, the releasable connection may according to the invention be formed by a releasable coupling, which can be released during the operation.  
30 This embodiment of the invention is particularly advantageous in

allowing a change of the direction of the resulting force component of the vibration-compensating apparatus during the operation. As a result, when the rotary bodies rotate in vertical planes, i.e. about horizontal axes, it is possible to start the vibration-compensating apparatus with the rotary  
5 bodies in a position, in which a horizontally resulting force component is generated and the starting moment is low, and subsequently to move the rotary bodies into a position corresponding to the desired compensating direction, for instance vertical.

Furthermore, each rotary body of the first compensator unit and each  
10 rotary body of the second compensator unit may be driven by a respective driving motor. In this manner, it is possible during the running of the vibration-compensating apparatus to change the direction of the force component of each of the two compensator units as well as the phase difference between the force components of the two compensator units, whereby it  
15 is possible to change both the direction and the magnitude of the resulting harmonic force component of the vibration-compensating apparatus during operation.

Moreover, according to the invention, the rotary bodies of the two compensator units may have the same eccentric mass with the effect that the  
20 resulting harmonically varying force component can be adjusted in an infinitely variable manner between zero and four times the force provided by each rotary body. In this connection, it is particularly advantageous with respect to the production that the rotary bodies are identically shaped.

25 Moreover, the rotary bodies of the two compensator units may according to the invention be arranged in a common housing. This embodiment is considered the most advantageous embodiment for achieving a vibration-compensating apparatus being as compact as possible.

Moreover, the axes of the rotary bodies may according to the invention be arranged such that they form the corners of a parallelogram, when seen in axial direction. This embodiment of the invention allows a particularly compact vibration-compensating apparatus, especially when the rotary

5 bodies of the compensator unit according to a further embodiment of the invention are axially displaced in such a manner that diagonally arranged rotary bodies are arranged in the same plane, whereby the axes of each compensator unit may advantageously be interspaced in such a manner that the rotary bodies thereof sweep a common area when seen in the

10 axial direction. In this connection, a further compactness can be obtained when the rotary bodies of the two compensator units not being in the same plane are also arranged such that they sweep a common area. In the latter case, however, it must be ensured that the diagonally arranged rotary bodies do not sweep a common area.

15 Finally, each compensator unit may according to the invention comprise a sensor for at least each single driving motor driving the rotary bodies thereof, said sensor continuously detecting the position and the rpm of the rotary body/bodies driven by said driving motor, as well as a speed sensor continuously detecting the speed of the at least one driving motor or the

20 rotary body/bodies driven thereby.

#### Brief Description of the Drawings.

The invention is explained in detail below with reference to the drawing, in which

Fig. 1 is a diagrammatic, top view of an embodiment of a vibration-compensating apparatus according to the invention with four identical rotary

25 bodies,

Fig. 2 is a sectional view taken along the line A-A of Fig. 1,

Fig. 3 is a top view of the reference position of the rotary bodies,

Fig. 4 illustrates the variation of the force component of each rotary body in the force direction of the vibration-compensating apparatus shown in Figs. 1, 2, and 3, said force direction being vertical, as seen in Figs. 1 and 5 3,

Fig. 5 illustrates the resulting force component of the vibration-compensating apparatus when said apparatus is set to provide maximum force, as shown in Fig. 3,

Fig. 6 illustrates the resulting force component of the vibration-compensating apparatus when said apparatus is set to provide half force, as shown 10 in Figs. 1 and 2,

Fig. 7 illustrates the variation of the resulting force of the vibration-compensating apparatus at a phase-displacement of the force,

Fig. 8 is a diagrammatic, top view of the vibration-compensating apparatus, when it is set to provide a resulting force displaced  $30^\circ$  relative to 15 vertical,

Fig. 9 is a diagrammatic view of the vibration-compensating apparatus according to the invention used for compensating for vibrations generated by an engine of a vessel,

20 Fig. 10 is a diagrammatic, top view of a second embodiment of a vibration-compensating apparatus according to the invention with four identical rotary bodies, and

Fig. 11 is a sectional view taken along the line B-B of Fig. 10.



Best Mode for Carrying Out the Invention

The embodiment of a vibration-compensating apparatus according to the invention shown in Figs. 1, 2, and 3 comprises a housing 1 with a cylindrical wall 2, an upper end wall 3, a lower end wall 4, as well as an intermediary wall 5. The end walls 3 and 4 are secured to the cylindrical wall by means of screws 6 shown by means of their centre line. An upper chamber 7 is formed between the upper end wall 3 and the intermediary wall 5, access to said chamber being allowed through openings 8 and 11 in the cylindrical wall 2. The openings 8 and 11 can be closed by means of covers 9 and 12. A lower chamber 10 is formed between the intermediary wall 5 and the lower wall 4.

The lower end wall 4 comprises an outward recess 13 covered by means of a bottom cover 14 so as to form a lubricant chamber 15, from which lubricant is supplied to the bearings and gear wheels of the vibration-compensating apparatus through lubricant pipes not shown. Finally, the lower end wall 4 forms a projecting flange 16 provided with mounting openings 17 shown by means of their centre line and used for bolting the vibration-compensating apparatus onto a base.

Four shafts 18, 19, 20, 21 are arranged in the interior of the housing 1, the axes 58, 59, 60, 61 of said shafts being positioned in the corners of a parallelogram, when seen in axial direction. Two diagonally arranged shafts 18, 20 are supported by bearings arranged in the upper end wall 3 and the intermediary wall 5. The remaining two diagonally arranged shafts 19, 21 are supported by bearings arranged in intermediary wall 5 and the lower end wall 4. A rotary body 22, 23, 24, 25 is arranged on each shaft 18, 19, 20, 21, said rotary bodies in the axial direction being shaped substantially as a sector of a circle and accordingly presenting an eccentrically positioned mass centre.

The shafts 18, 19, 20, 21 and the rotary bodies 22, 23, 24, 25 arranged thereon are furthermore arranged in such a way inside the housing 1 that the diagonally arranged upper shafts 18, 20 are interspaced such that their rotary bodies rotating in the same plane do not sweep a common area.

5 However, the shafts 18, 19; 21, 20 of the two compensator units with rotary bodies rotating in different planes are arranged so close that the rotary bodies 22, 23; 24, 25 sweep a common area during their rotation. Correspondingly, the upper shaft 18, 20 of one compensator unit is arranged so close to the lower shaft 19, 21 of the second compensator unit

10 that the upper rotary body 22, 24 of one compensator unit sweeps a common area with the lower rotary body 23, 25 of the second compensator unit. The resulting vibration-compensating apparatus is very compact, and the base on which said apparatus is mounted is not subjected to further moments, when the force direction of the vibration-compensating

15 apparatus is changed.

Each upper shaft 18, 20 extends through the upper end wall 3 and comprises a projecting shaft end 26, on which a disk 27, 28 is mounted. Two motors 29, 30 with a variable rpm, such as servomotors, are mounted on the outer side of the housing. One motor 29 drives the disk 27 on the

20 shaft end 26 of the shaft 18 by means of a disk 31 mounted on the output shaft thereof and a toothed belt 33. Correspondingly, the second motor 28 drives the disk 28 and consequently, the shaft 20 by means of a disk 32 mounted on the shaft end thereof and a toothed belt 34. The driving connections between the motors 29, 30 and the upper shafts 18,

25 20 are shielded by means of shields 56, 57.

Each lower shaft 19, 21 extends slightly into the upper chamber 7 through the intermediary wall 5. A gear wheel 36 is mounted on the shaft end 35 accommodated in the upper chamber. The gear wheel 36 engages a mating gear wheel 37 mounted on each of the upper shafts 18, 20 between

30 the rotary body 22, 24 in question and the intermediary wall 5. The gear

wheels 36 on the shaft ends 35 of the lower shafts 19, 21 projecting into the upper chamber are releasably arranged so as to be released for rotation. The gear wheels 36 of the illustrated embodiment can be turned relative to the shaft ends 35 by pressurized fluid being fed through a channel 38 to the mounting area of the gear wheel 36 in question on the shaft end 35. The releasable gear wheels 36 can, however, be mounted by means of a wide range of different releasable shaft/hub connections, such as for instance a conical friction coupling or another connecting means which allows a fast release of the connection between the shaft and the gear wheel mounted thereon. A coupling releasable by way of remote control may advantageously be used between the gear wheel 36 and the shaft end 35. Such a releasable coupling 39 is shown by means of dotted lines in Fig. 2.

A first compensator unit is formed by means of the upper rotary body 22 driven by one motor 29 and the lower rotary body 23 driven in opposite direction by means of the gear wheel connection. Correspondingly, a second compensator unit is formed by the second upper rotary body 24 driven by the second motor 30 and the second lower rotary body 25 driven in opposite direction by means of the gear wheel connection. The rotary body of each compensator unit generates a harmonically varying force component in vertical direction, as seen in Fig. 1, said force component varying between  $-1/4 F_c$  and  $+1/4 F_c$ , where  $F_c$  is the maximum total force component of the vibration-compensating apparatus. The latter is shown in Fig. 4, where the position of the rotary bodies shown in Fig. 3 is used as reference position, for which reason said rotary bodies do not generate a force component in vertical direction at  $0^\circ$ ,  $\pi$  and  $2\pi$ . Correspondingly, Fig. 5 shows the variation of the maximum resulting force component  $F_c$  for the vibration-compensating apparatus, i.e. when the two compensator units are set so as to simultaneously provide the maximum force as shown in Fig. 3. In this connection, it should be mentioned that the vibration-compensating apparatus shown in Figs. 1 and 2 does not

provide its maximum force, but half force, because one compensator unit, i.e. the compensator unit including the rotary bodies 22 and 23, has been displaced  $-60^\circ$  relative to the reference position in Fig. 3, in which the vibration-compensating apparatus provides its maximum resulting force, and the second compensator unit including the rotary bodies 24 and 25 has been displaced  $+60^\circ$  relative to the reference position. The latter appears from Fig. 6, in which the force component of the compensator unit comprising the rotary bodies 22 and 23 is shown by means of a broken line, the force component of the compensator unit comprising the rotary bodies 24, 25 is shown by means of a dotted line, and the resulting force component by means of a full-drawn line.

Finally, four sensors 40, 41, 42, 43 are arranged in the cylindrical wall 2 of the housing 1, said sensors detecting the passage of a point on the rotary bodies. The point is formed of a screw head 50, 51, 52, 53 of a screw screwed into the rotary bodies on a radial line through the eccentric mass centre thereof. In the present case, the sensors 40, 41 of one compensator unit are arranged so as to indicate a rotation of the rotary bodies 22, 23 of  $3/2\pi$  from the reference position shown in Fig. 3, and the sensors 42, 43 of the second compensator unit are arranged so as to indicate a rotation the rotary bodies 24, 25 of  $\pi/2$  from the said reference position.

In order to change the force direction of the resulting force component of the vibration-compensating apparatus relative to the direction shown in Figs. 1 and 3, the gear wheel 36 on the two lower shafts 19, 21 is released by pressurized fluid being fed thereto through their channels 38. Subsequently, the two upper shafts 18, 20 are turned twice the angle of the desired change of direction, and the gear wheels 36 of the lower shafts 19, 21 is again fastened. Fig. 8 illustrates the position of the rotary bodies at a maximum resulting force after the latter has been changed  $+30^\circ$  relative to its direction shown in Figs. 1 and 3. A change of the force direction causes a simultaneous change of the point during the cycle of

the vibration-compensating apparatus at which the sensors detect the passage of the screw heads on the rotary bodies, when seen relative to the direction of the force. Thus, on each compensator unit the screw head 51,53 of one of the rotary bodies 23, 25 passes the sensor 41, 43 a an  
5 angle of rotation later corresponding to the angular change of force direction, and the screw head 50, 52 of the second rotary body 22, 24 passes the sensor 40, 42 the said angle earlier. After the change of the force direction, the magnitude of the resulting force can be changed by the changing the phase between the two compensator units, as explained  
10 above.

Reference is now made to Fig. 9, where the control and the setting of a vibration-compensating apparatus according to the invention will be described in greater detail, the vibration-compensating apparatus of the example being used for counteracting the vibrations generated by the main engine  
15 of a ship or another excitation source on board the ship.

A sensor 45 continuously detects a reference position on the main shaft 47 of the main engine as well as the rpm thereof. The reference position may typically be the top position of the first cylinder measured on the main shaft 47 of the engine 46. The speed of the main engine 46 is also  
20 continuously detected by means of a speed sensor (pulse burst/sensor) 48. The position and the speed of the reference position is continuously detected by a control and synchronizing device 49. In addition, the control and synchronizing device 49 continuously detects the speed of the motor 29 of the first compensator unit and the motor 30 of the second compensator  
25 unit by means of speed sensors 54, 55, as well as the position and rpm of the four rotary bodies by means of the sensors 40, 41, 42, 43. Furthermore, the control and synchronizing device is supplied with data on the phase difference between the excitation source to be compensated for and the reference position on the main shaft of the engine.

The signals measured on the main shaft 47 of the engine are compared in the control and synchronizing device 49 with the signals reflecting the speed of the servomotors 29 and 30 as well as with the signals from the sensors 40, 41, 42, 43 reflecting the position and rpm of the vibration--  
5 compensating apparatus. Based on the latter, the rotating speed of the motors 29, 30 of the compensator units is continuously adjusted in such a manner that the vibration-compensating apparatus runs synchronously with and with the desired phase angle relative to the main engine and consequently relative to the excitation source, and further such that it  
10 provides the compensating force desired for compensating for the immediate vibrations generated by the excitation source.

When the magnitude of the force is to be changed, the synchronizing of one compensator unit is changed by a corresponding positive angle and of the second compensator unit by a corresponding negative angle, as pre-  
15 viously explained in connection with Figs. 1, 3, and 6. The magnitude of the force can be changed either based on data encoded in the control and synchronizing device 49 in advance or based on signals transmitted to the control and synchronizing device 49 from a vibration-measuring device (for instance an accelerometer). A change of the magnitude of the force does  
20 not involve a change of the phase angle between the force and the reference position on the engine provided the magnitude of the force is changed in the manner described above. The magnitude of the force can, of course, also be changed merely by changing the synchronizing of one of the compensator units relative to the reference position. Thus, half force  
25 can also be obtained by changing the synchronizing of one compensator unit relative to the reference position by  $120^\circ$  and by not changing the setting of the second compensator unit. As a result, a phase displacement occurs of the force of the vibration-compensating apparatus and of the reference position on the marine engine, said phase displacement corre-  
30 sponding to half the angle which the synchronizing of the compensator unit is changed relative to the reference position, i.e.  $60^\circ$  in the present

case. When this method is used for changing the magnitude of the force, the data on the changed phase angle between the force of the vibration-compensating apparatus and the reference position on the engine is or will be entered in the control and synchronizing device 49.

- 5 When the phase angle is to be changed, the synchronizing of both compensator units is changed corresponding to the desired phase angle. Thus, Fig. 7 shows an increase of the phase angle of the vibration-compensating apparatus relative to the main engine by  $+60^\circ$ . The change of the phase angle can also be performed based either on data encoded in the control  
10 and synchronizing device 49 in advance or based on signals transmitted thereto from a vibration-measuring device.

When the force direction is changed as described in connection with Fig. 8, the phase angle is simultaneously correspondingly changed, by  $+30^\circ$  in the example referred to. After the change of the force direction, the same  
15 methods are used for setting the magnitude of the force and the phase, cf. above, but now relative to the force direction changed by  $+30^\circ$ .

The embodiment shown in Figs. 10 and 11 of a vibration-compensating apparatus according to the invention comprises a housing 101 with a cylindrical wall 102, an upper end wall 103, and a lower end wall 104.  
20 The upper end wall 103 is secured to the cylindrical wall by means of screws 106 shown by means of their centre line. The lower end wall 104 comprises an outward recess 113 covered by means of a bottom cover 114 so as to form a lubricant chamber 115. The lower end wall 104 comprises furthermore a projecting flange 116 provided with mounting  
25 openings 117 shown by means of their centre line and used for bolting the vibration-compensating apparatus onto a base.

Four shafts 118, 119, 120, 121 are arranged in the interior of the housing 101, the axes 158, 159, 160, 161 of said shafts being positioned in the

corners of a square, when seen in axial direction. Each shaft is supported by bearings arranged in the upper end wall 103 and the lower end wall 104. A rotary body 122, 123, 124, 125 is arranged on each shaft 118, 119, 120, 121, said rotary bodies in the axial direction being shaped  
5 substantially as a sector of a circle and accordingly presenting an eccentrically positioned mass centre. The shafts 118, 119, 120, 121 and the rotary bodies 122, 123, 124, 125 arranged thereon are furthermore arranged in such a way that during rotation no rotary body sweeps an area which is common with the area swept by a second rotary body during  
10 rotation.

Each shaft 118, 119, 120, 121 extends through the upper end wall 103 and comprises a projecting shaft end 126, on which a disk 127 is mounted. Four motors 128, 129, 130, 131 with a variable rpm, such as servomotors, are mounted on the outer side of the housing 101. Each motor  
15 drives the disk 127 on the shaft ends 126 of the shafts 118, 119, 120, 121 by means of a disk 132 mounted on its output shaft and a toothed belt 133. The driving connections between the motors 128, 129, 130, 131 and the shafts 118, 119, 120, 121 are shielded by means of shields 156.

20 The rotary bodies 122 and 123 are driven in opposite directions by means of the motors 128 and 129 at the same rpm and form a first compensator unit. Correspondingly, the rotary bodies 125 and 124 are driven in opposite directions at the same rpm by means of the motors 131 and 130 and form a second compensator unit. As explained in connection with Figs. 1  
25 to 9, the rotary body of each compensator unit generates a harmonically varying force component in vertical direction, cf. Fig. 10, which varies between  $-1/4 F_c$  and  $+1/4 F_c$ , where  $F_c$  is the maximum, total force component for the vibration-compensating apparatus. It should, furthermore, be mentioned that the vibration-compensating apparatus shown in Figs. 10  
30 and 11 is shown in a position corresponding to the vibration-compensating



apparatus of Figs. 1 and 2, i.e. a position, in which it provides half force, because the first compensator unit with the rotary bodies 122 and 123 is displaced  $-60^\circ$  relative to the reference position of Fig. 3, and the second compensator unit with the rotary bodies 124 and 125 is displaced  $+60^\circ$  relative to the reference position.

Finally, four sensors 140, 141, 142, 143 are arranged in the upper end wall 103 of the housing 101, said sensors detecting the passage of a point on the rotary bodies. The point is a screw head 150, 151, 152, 153 of a screw screwed axially into the rotary bodies on a radial line through the eccentric mass centre thereof. In the present case, the sensors 140, 141 of the first compensator unit with the rotary bodies 122, 123 are arranged so as to indicate a rotation of said rotary bodies 122, 123 of  $3/2\pi$  from the reference position shown in Fig. 3, and the sensors 142, 143 of the second compensator unit with the rotary bodies 124, 125 are arranged so as to indicate a rotation of said rotary bodies 124, 125 of  $\pi/2$  from said reference position. Furthermore, each of the motors 128, 129, 130, 131 are provided with a speed sensor 164, 165, 166, 167 continuously detecting the speed of the motor in question and consequently of the rotary body 122, 123, 124, 125 driven thereby. The position and the speed of the rotary bodies are as previously described in connection with Fig. 9 continuously detected by the control and synchronizing device 49.

The magnitude of the resulting force component is as previously described changed by changing the phase difference between the first compensator unit with the rotary bodies 122 and 123 and the second compensator unit with the rotary bodies 124 and 125. The direction of the resulting force component of the vibration-compensating apparatus can be changed relative to the direction shown in Figs. 10 and 11 by changing the phase difference between the rotary bodies 122, 123 of the first compensator unit in such a manner that the screw head 150 on the rotary body 122 passes the sensor 141 an angle of rotation earlier corresponding to the

intended angular change of the force direction, and furthermore in such a manner that the screw head 151 on the rotary body 123 passes the sensor 141 an angle of rotation later corresponding to the intended angular change of the force direction. Correspondingly, the phase difference between the rotary bodies 124 and 125 of the second compensator unit is  
5 changed in such a manner that the screw head 142 on the rotary body 124 passes the sensor 152 an angle of rotation earlier corresponding to the intended angular change of the force direction, and in such a manner that the screw head 53 on the rotary body 125 passes the sensor 143 an  
10 angle of rotation later corresponding to the intended angular change of the force direction. The change of the force direction is positive in the clockwise direction shown in Fig. 10. Thus, when the force direction is to be changed  $30^\circ$  relative to vertical as shown in Fig. 10, the phase difference between the rotary bodies of the two compensator units is changed  $30^\circ$   
15 in the manner described above. In practice, the latter is carried out by briefly accelerating and decelerating the rotational speeds of the rotary bodies in question, until the desired phase displacement has been obtained. It is thus possible during the running of the apparatus to change the magnitude as well as the direction of the resulting harmonic force  
20 component of the vibration-compensating apparatus.

Concerning the control of the vibration-compensating apparatus relative to an excitation source by means of the control and synchronizing device 49, reference is made to the explanation related to Fig. 9 of the vibration-compensating apparatus shown in Figs. 1 to 8.

25 The invention can be changed in many ways without thereby deviating from the scope thereof. Thus, the axes of the rotary bodies can be arranged side by side and thereby in the same plane instead of coinciding with the corners of a parallelogram. As an alternative, the axes of the rotary bodies can be coaxially arranged. Moreover, the rotary bodies of the  
30 vibration-compensating apparatus can also rotate about horizontal axes or

inclining axes instead of about vertical axes. Finally, the compensator units can be arranged in separate housings instead of in a common housing.

Claims

1. A vibration-compensating apparatus for counteracting harmonic vibrations from an excitation source, such as vibrations generated by an engine of a vessel, said apparatus comprising a first compensator unit with  
5 two rotary bodies (22, 23; 122, 123) with the same eccentric mass, and rotating at the same rpm in opposite direction about mutually parallel axes so as to generate a harmonically varying force component in one direction, and a second compensator unit also provided with two rotary bodies (24, 25; 124, 125) with the same eccentric mass and rotating at the same rpm  
10 as the rotary bodies (22, 23) of the first compensator unit in opposite directions about parallel axes parallel to the axes of the first compensator unit so as to generate a second harmonically varying force component in a direction parallel to the first harmonically varying force component,  
c h a r a c t e r i s e d in that the rotary bodies (22, 23; 122, 123) of the  
15 first compensator unit are driven by at least one first infinitely variable driving motor (29; 128, 129), that the rotary bodies (24, 25; 124, 125) of the second compensator unit are driven by at least one second infinitely variable driving motor (30; 130, 131), and that the vibration-compensating apparatus furthermore comprises a control and synchronizing device (49)  
20 for controlling the driving motors (29, 30; 128, 129, 130, 131) of the compensator units in such a manner that the rotary bodies rotate at an rpm which is a multiple of the frequency of the excitation source.

2. A vibration-compensating apparatus as claimed in claim 1, c h a r a c t e r i s e d in that the rotary bodies (22, 23) of the first compensator  
25 unit are driven by a single first driving motor (29) and are interconnected by means of a first transmission (36, 37) for rotation in opposite directions, and that the rotary bodies (24, 25) of the second compensator unit are driven by a single second driving motor (30) and are interconnected by means of a second transmission (36, 37) for rotation in opposite direc-  
30 tions.

3. A vibration-compensating apparatus as claimed in claim 2, c h a r a c t e r i s e d in that the transmission (36, 37) between the two rotary bodies (22, 23, 24, 25) of each compensator unit comprises a releasable connection allowing a rotating of the two rotary bodies relative to one  
5 another so as to change their mutual position.
4. A vibration-compensating apparatus as claimed in claim 3, c h a r a c t e r i s e d in that the releasable connection is a releasable coupling (39), which can be released by way of remote control during a running of the apparatus.
- 10 5. A vibration-compensating apparatus as claimed in claim 1, c h a r a c t e r i s e d in that each rotary body (122, 123) of the first compensator unit and each rotary body (124, 125) of the second compensator unit are driven by a respective driving motor (128, 129, 130, 131).
6. A vibration-compensating apparatus as claimed in one or more of  
15 the preceding claims, c h a r a c t e r i s e d in that the rotary bodies (22, 23, 24, 25; 122, 123, 124, 125)) of the two compensator units have the same eccentric mass.
7. A vibration-compensating apparatus as claimed in one or more of the preceding claims, c h a r a c t e r i s e d in that the rotary bodies (22,  
20 23, 24, 25; 122, 123, 124, 125) of the two compensator units are arranged in a common housing (1; 101).
8. A vibration-compensating apparatus as claimed in one or more of the preceding claims, c h a r a c t e r i s e d in that the axes (58, 59, 60, 61; 158, 159, 160, 161) of the rotary bodies (22, 23, 24, 25; 122, 123,  
25 124, 125) are arranged such that they form the corners of a parallelogram, when seen in the axial direction.

9. A vibration-compensating apparatus as claimed in claim 8, c h a r a c t e r i s e d in that the rotary bodies of each compensator unit is axially displaced in such a manner that diagonally arranged rotary bodies (22, 24; 23, 25) are arranged in the same plane, and that the axes (58, 59; 60, 61) of each compensator unit are interspaced such that their rotary bodies (22, 23, 24, 25) sweep a common area, when seen in axial direction.

10. A vibration-compensating apparatus as claimed in one or more of the preceding claims, c h a r a c t e r i s e d in that each compensator unit (22, 23; 24, 25; 122, 123; 124, 125) comprises a sensor (40, 41, 42, 42; 140, 141, 142, 143) for each driving motor (29, 30; 128, 129, 130, 131) driving the rotary bodies thereof, said sensor detecting the position and the rpm of the rotary body/bodies driven by said driving motor, each compensator unit further comprising a speed sensor (54, 55; 164, 165, 166, 167) for continuously detecting the speed of the at least one driving motor or the rotary body/bodies driven thereby.

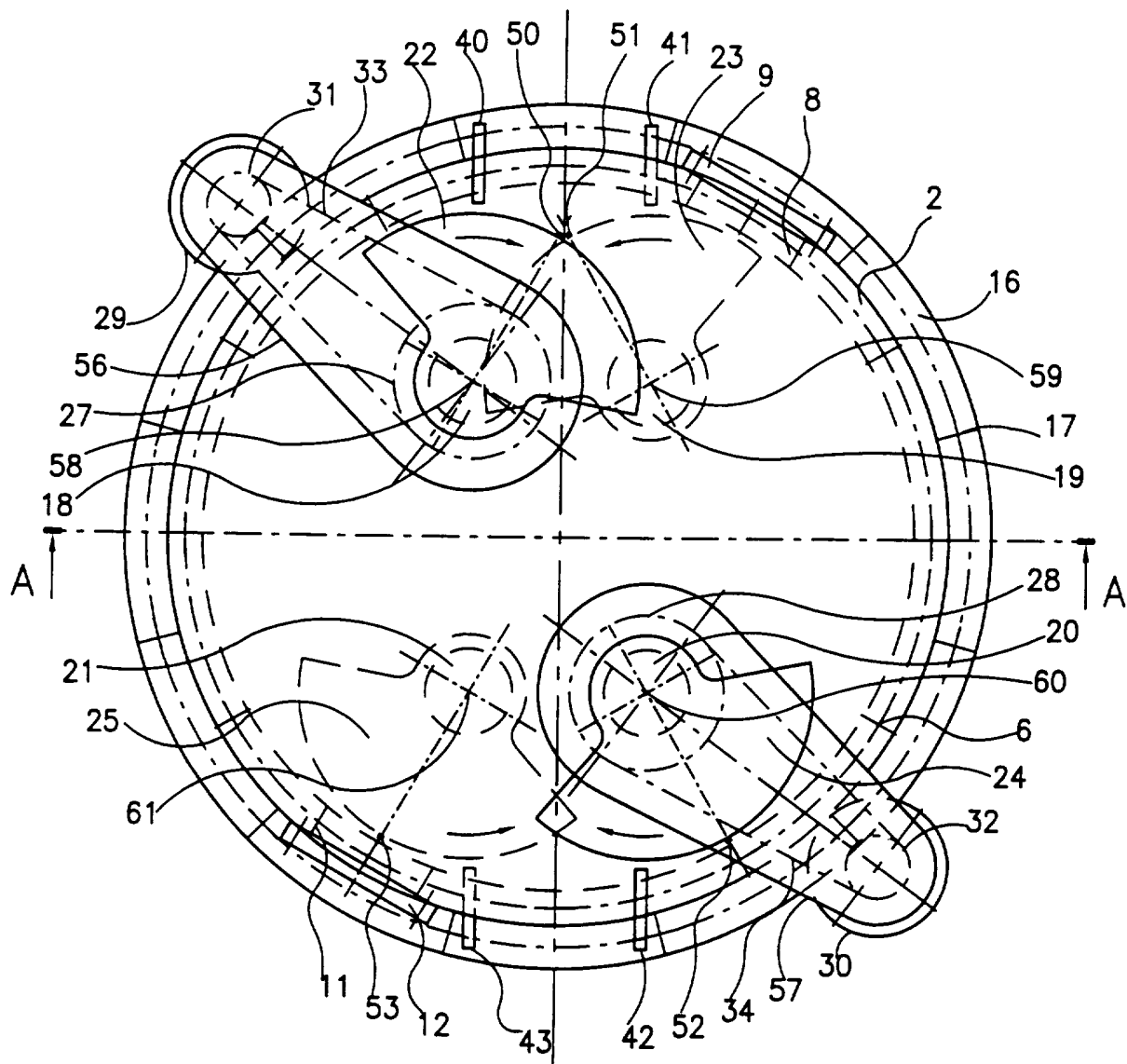

FIG. 1

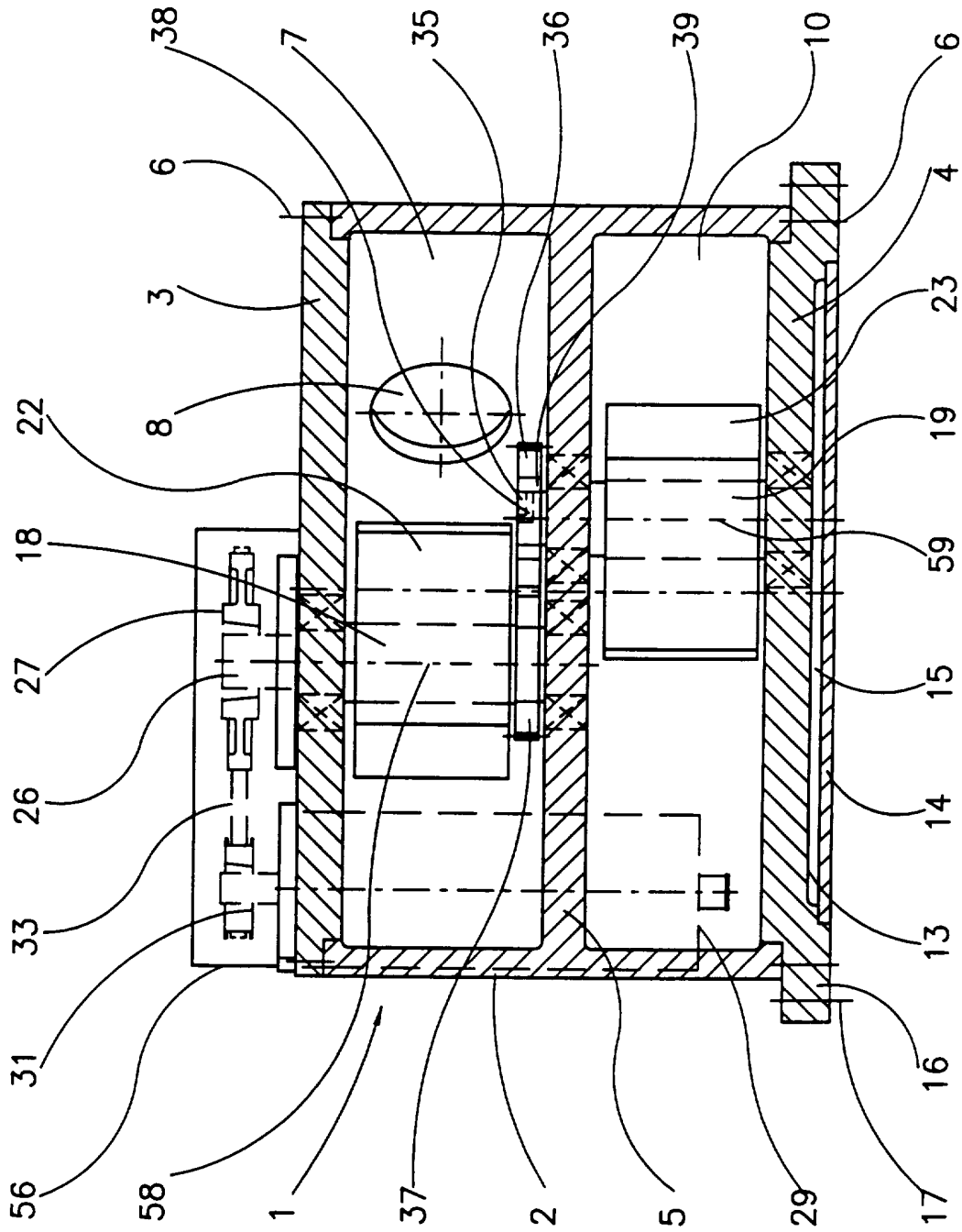

FIG. 2



3/9

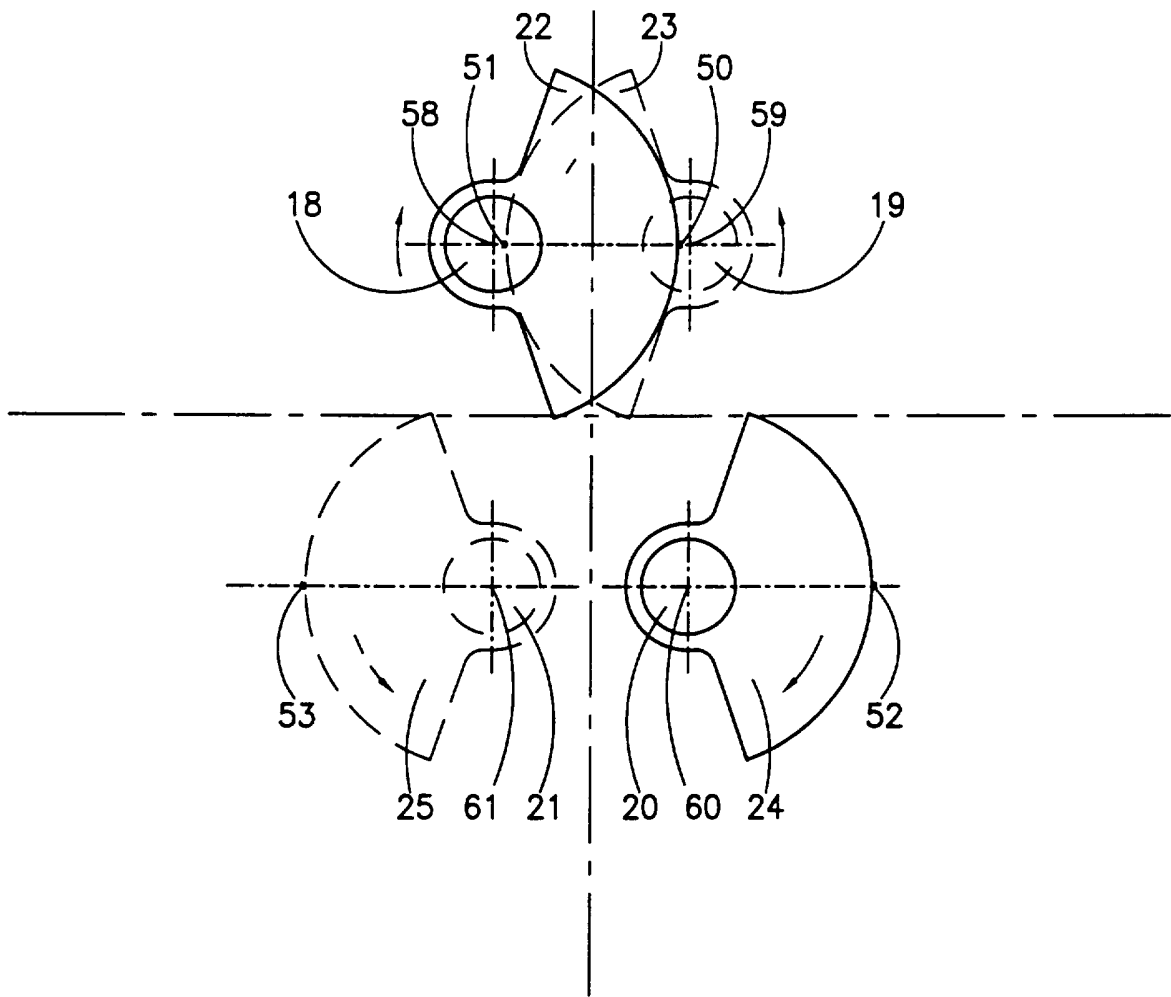

FIG. 3

4/9

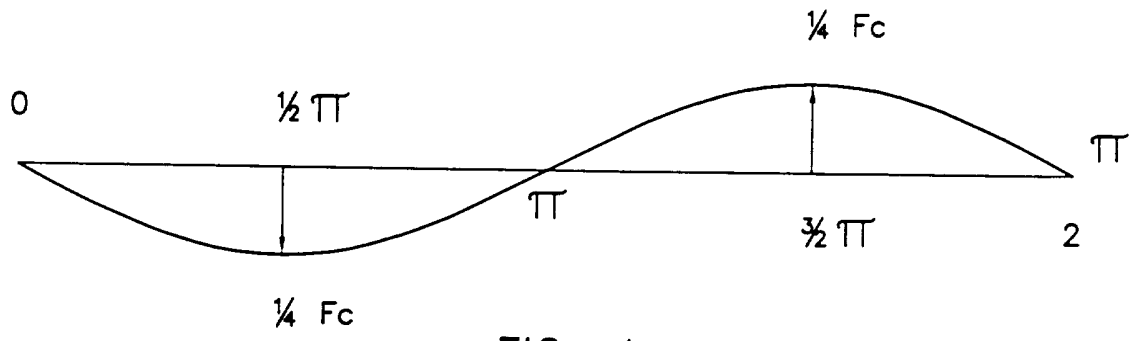

FIG. 4

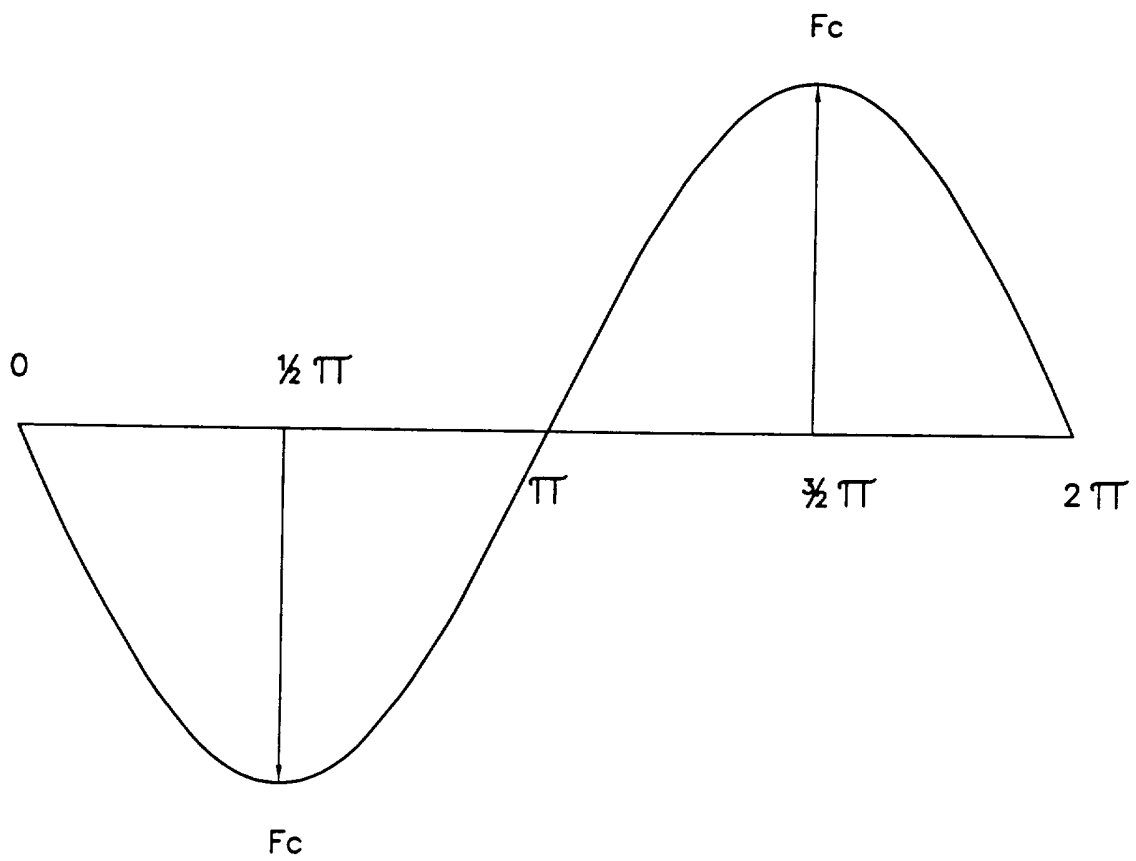

FIG. 5

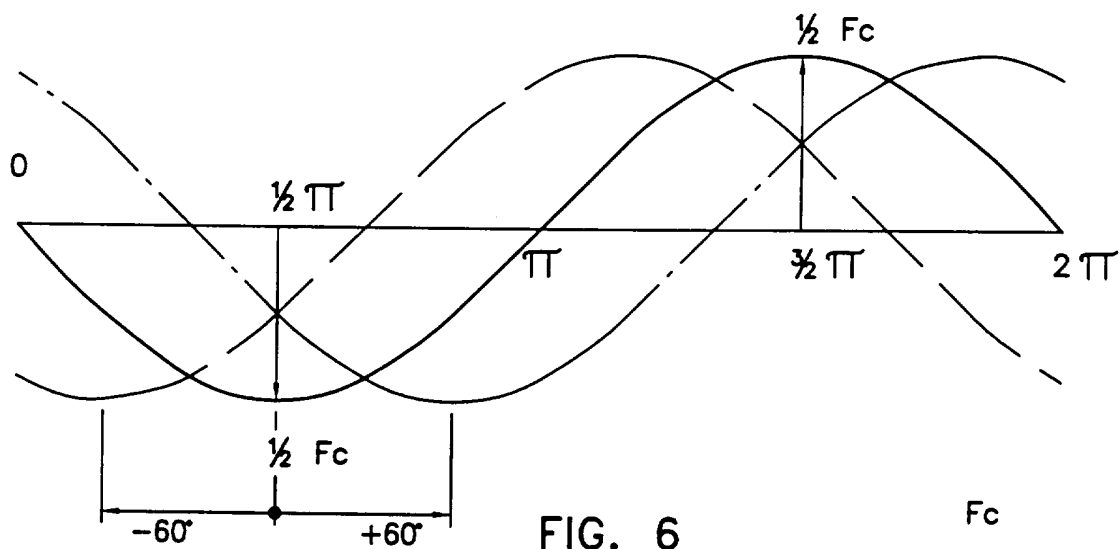

FIG. 6

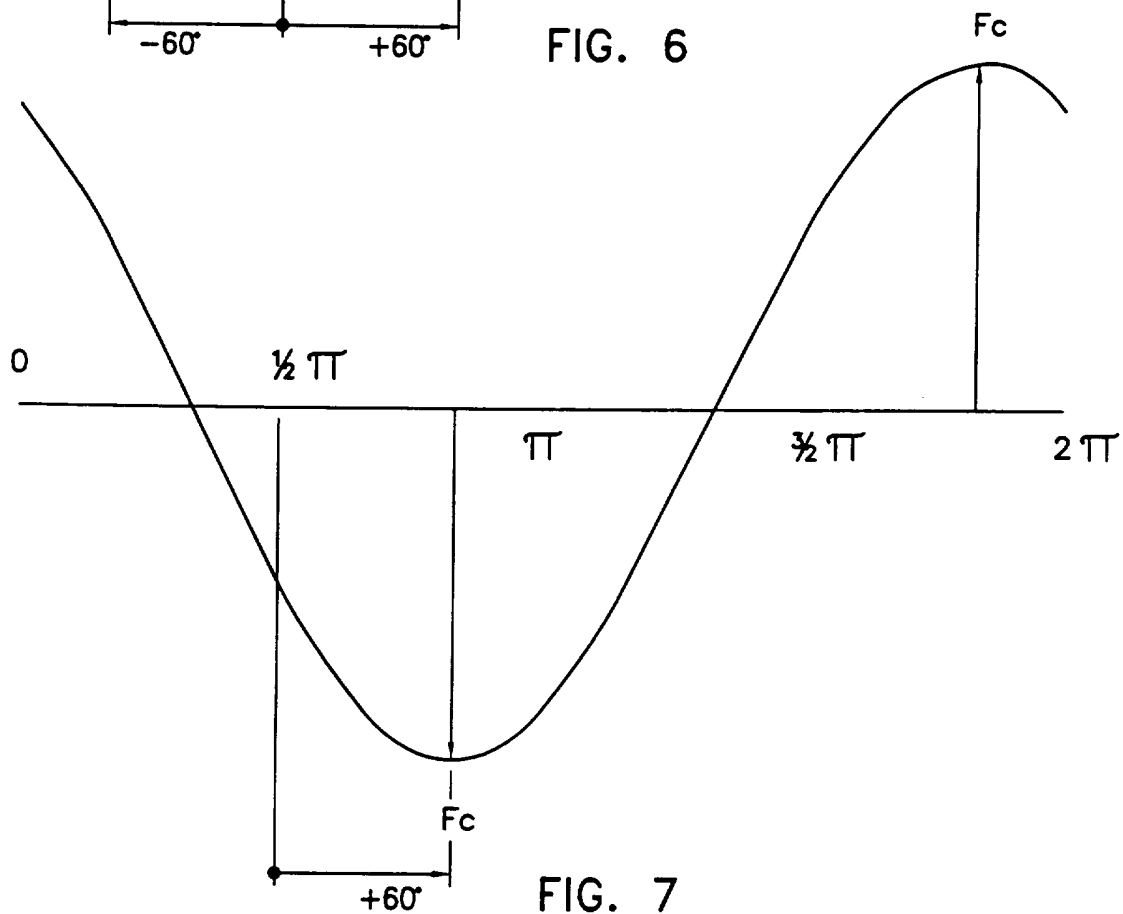

FIG. 7

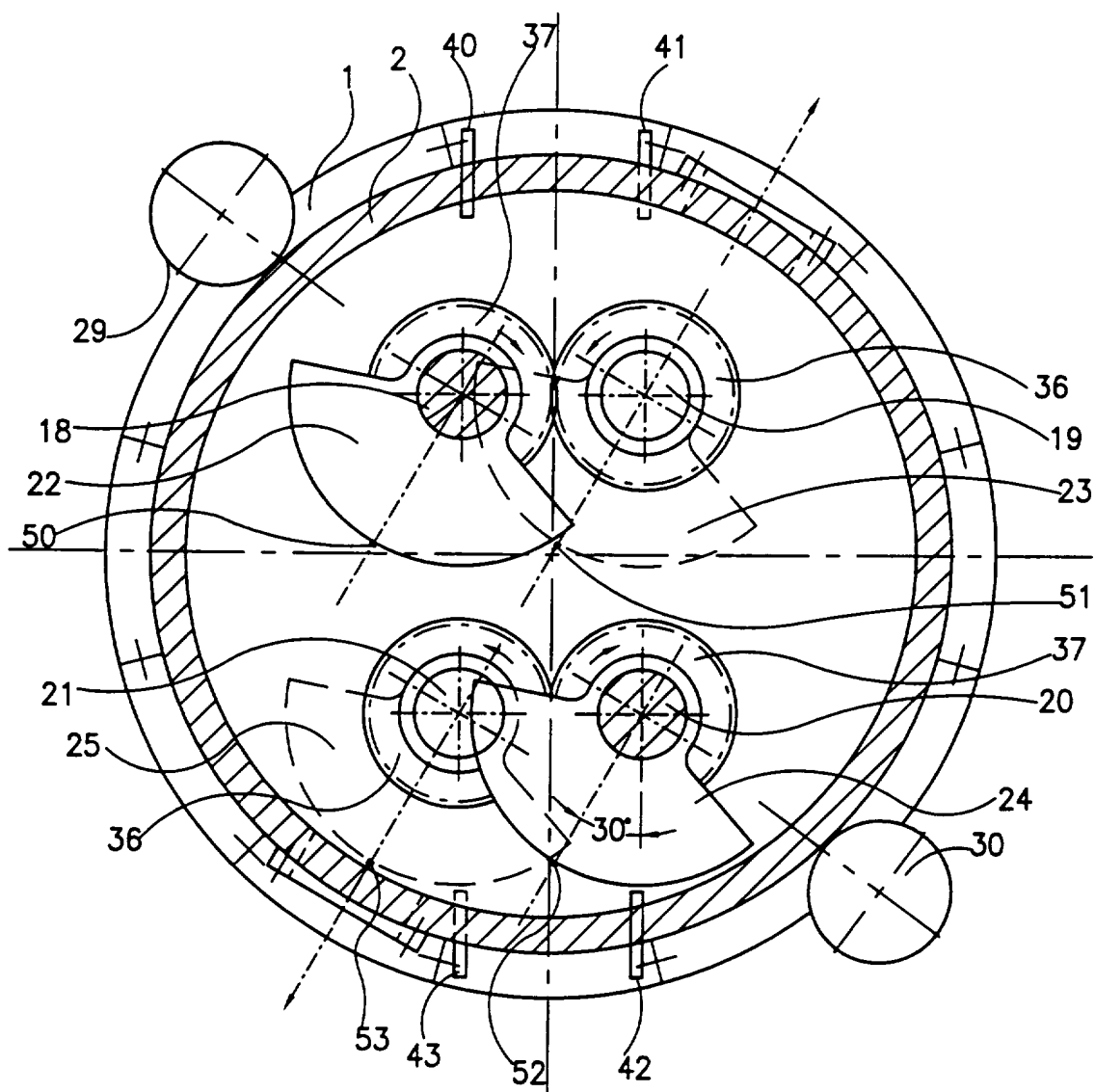

FIG. 8

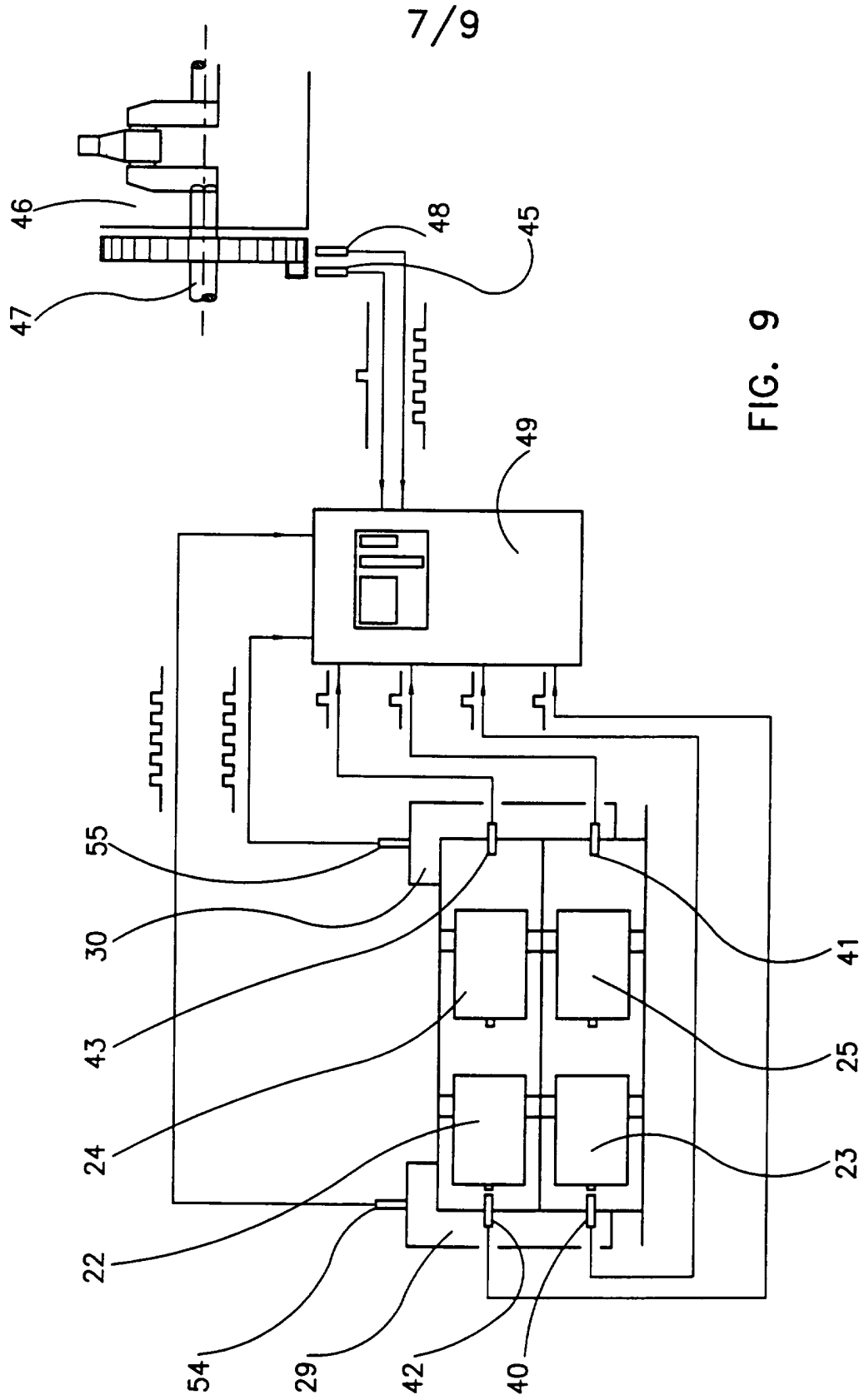

FIG. 9

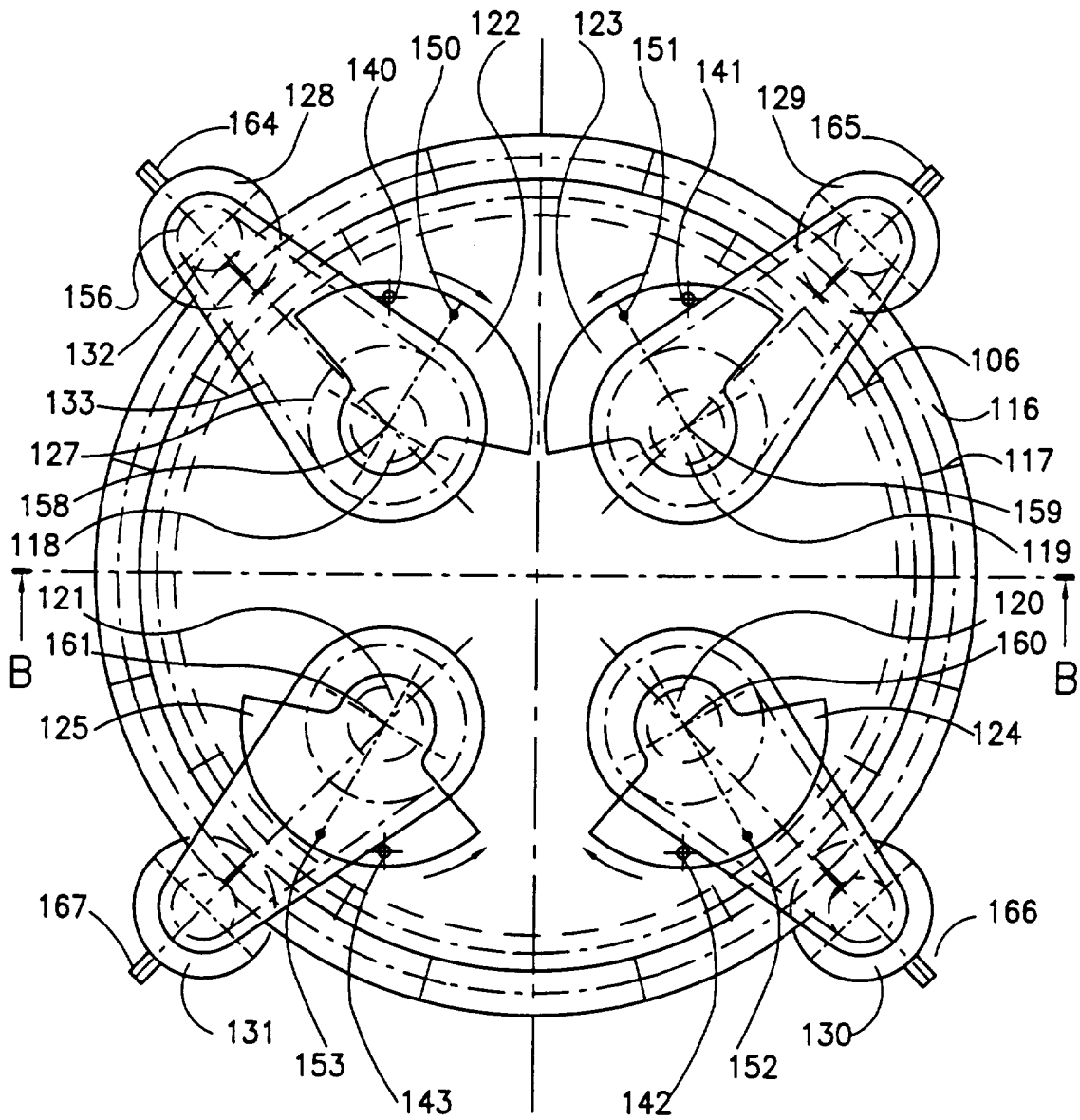

FIG. 10

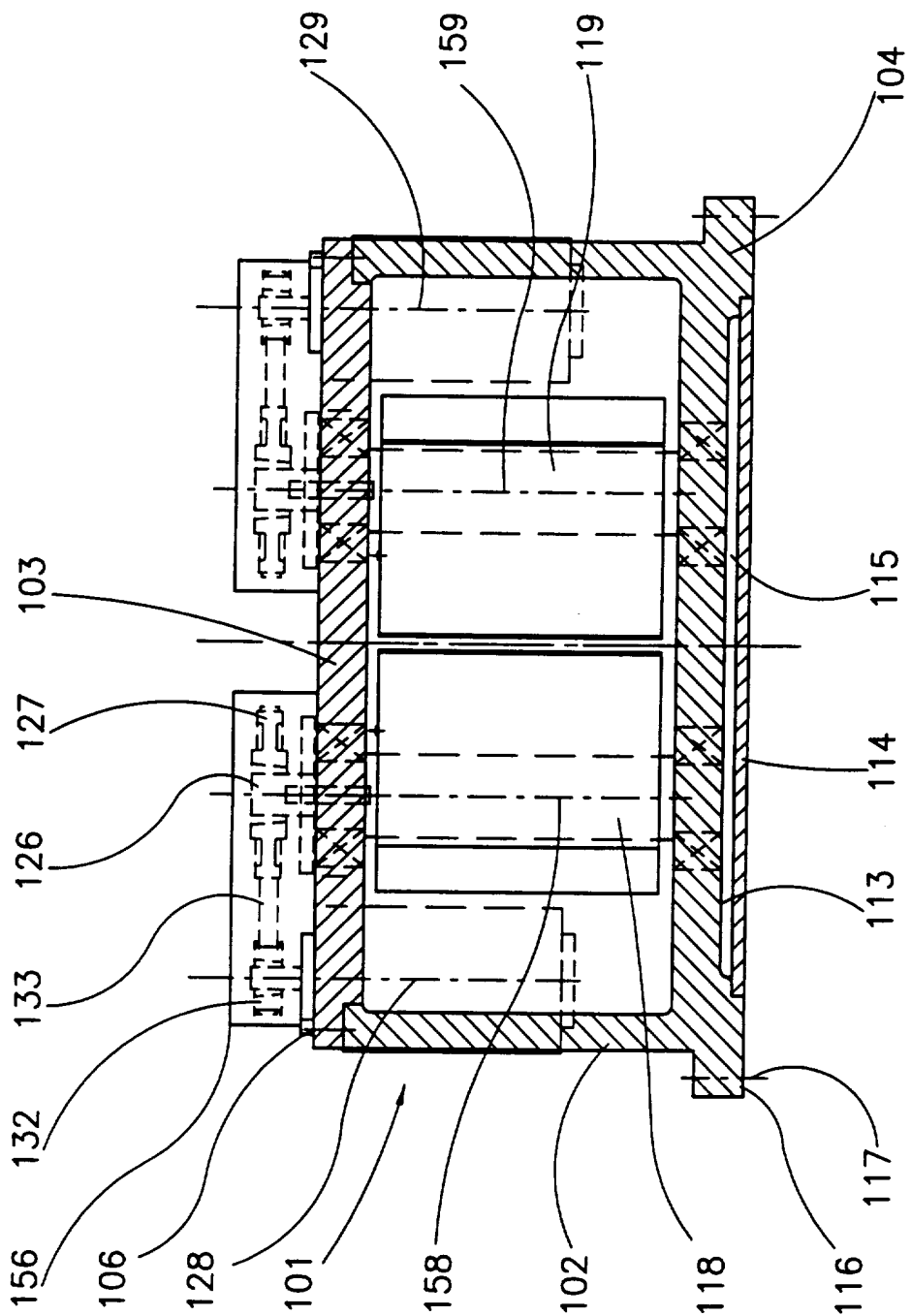

FIG. 11

## INTERNATIONAL SEARCH REPORT

International application No.

PCT/DK 95/00340

## A. CLASSIFICATION OF SUBJECT MATTER

IPC6: F16F 15/22 // B63H 21/30

According to International Patent Classification (IPC) or to both national classification and IPC

## B. FIELDS SEARCHED

Minimum documentation searched (classification system followed by classification symbols)

IPC6: F16F, B63H

Documentation searched other than minimum documentation to the extent that such documents are included in the fields searched

SE,DK,FI,NO classes as above

Electronic data base consulted during the international search (name of data base and, where practicable, search terms used)

EPODOC, PAJ

## C. DOCUMENTS CONSIDERED TO BE RELEVANT

Category*	Citation of document, with indication, where appropriate, of the relevant passages	Relevant to claim No.
X	EP 0409462 A1 (BARRY WRIGHT CORPORATION), 23 January 1991 (23.01.91), column 5, line 9 - line 14, abstract --	1,5-7,10
X	DE 627949 C (MASCHINENFABRIK AUGSBURG-NÜRNBERG A.G.), 26 March 1936 (26.03.36), page 2, line 39 - line 47, figures 2-4 --	1-2,5-8
Y	--	3-4,9-10
Y	DK 169848 B1 (F.L. SMIDTH & CO. A/S), 16 June 1990 (16.06.90), figure 2, abstract --	3-4,9-10

 Further documents are listed in the continuation of Box C. See patent family annex.

## \* Special categories of cited documents:

"A" document defining the general state of the art which is not considered to be of particular relevance

"E" earlier document but published on or after the international filing date

"L" document which may throw doubts on priority claim(s) or which is cited to establish the publication date of another citation or other special reason (as specified)

"O" document referring to an oral disclosure, use, exhibition or other means

"P" document published prior to the international filing date but later than the priority date claimed

"T" later document published after the international filing date or priority date and not in conflict with the application but cited to understand the principle or theory underlying the invention

"X" document of particular relevance: the claimed invention cannot be considered novel or cannot be considered to involve an inventive step when the document is taken alone

"Y" document of particular relevance: the claimed invention cannot be considered to involve an inventive step when the document is combined with one or more other such documents, such combination being obvious to a person skilled in the art

"&amp;" document member of the same patent family

Date of the actual completion of the international search

29 November 1995

Date of mailing of the international search report

05.12.1995

Name and mailing address of the ISA/  
Swedish Patent Office  
Box 5055, S-102 42 STOCKHOLM  
Facsimile No. +46 8 666 02 86

Authorized officer

Marianne Dickman  
Telephone No. +46 8 782 25 00



## INTERNATIONAL SEARCH REPORT

International application No.

PCT/DK 95/00340

## C (Continuation). DOCUMENTS CONSIDERED TO BE RELEVANT

Category*	Citation of document, with indication, where appropriate, of the relevant passages	Relevant to claim No.
A	EP 0010973 A1 (BURMEISTER & WAIN A/S), 14 May 1980 (14.05.80) --	1
A	Patent Abstracts of Japan, Vol 7, No 81, M-205, abstract of JP, A, 58-8844 (MITSUBUSHI JUKOGYO K.K.), 19 January 1983 (19.01.83) --	1
A	EP 0348081 A2 (JAGUAR CARS LIMITED), 27 December 1989 (27.12.89) --	1
A	DE 292711 C (MASCHINENFABRIK AUGSBURG-NÜRNBERG A.G.), 23 June 1916 (23.06.16) --	1
A,P	WO 9502133 A1 (F.L. SMIDTH & CO. A/S), 19 January 1995 (19.01.95) -- -----	1-10

**INTERNATIONAL SEARCH REPORT**  
Information on patent family members

International application No.  
PCT/DK 95/00340

Patent document cited in search report	Publication date	Patent family member(s)	Publication date
EP-A1- 0409462	23/01/91	CA-A- 2020801 DE-D, T- 69008633 JP-A- 3149430 US-A- 5005439	15/01/91 24/11/94 26/06/91 09/04/91
DE-C- 627949	26/03/36	NONE	
DK-B1- 169848	16/06/90	NONE	
EP-A1- 0010973	14/05/80	SE-T3- 0010973 DE-A, C, C 2847770 JP-A- 55063033	08/05/80 12/05/80
EP-A2- 0348081	27/12/89	JP-A- 2085544 US-A- 4936268	27/03/90 26/06/90
DE-C- 292711	23/06/16	NONE	
WO-A1- 9502133	19/01/95	NONE	