



(19) **United States**

(12) **Patent Application Publication**

(10) **Pub. No.: US 2002/0030280 A1**

Lee et al.

(43) **Pub. Date:**

Mar. 14, 2002

(54) **SEMICONDUCTOR DEVICE HAVING DUAL DAMASCENE LINE STRUCTURE AND METHOD FOR FABRICATING THE SAME**

Publication Classification

(51) **Int. Cl.⁷** **H01L 23/053; H01L 23/12**

(52) **U.S. Cl.** **257/774; 257/700; 257/758; 257/701**

(75) Inventors: **Kyung-Tae Lee**, Kwacheon-city (KR);
Seong-Ho Liu, Yongin-city (KR)

(57) **ABSTRACT**

Correspondence Address:
MILLS & ONELLO, LLP
ELEVEN BEACON STREET
SUITE 605
Boston, MA 02108 (US)

A semiconductor device having a dual damascene line structure and a method for fabricating the same are disclosed. The semiconductor device and the method solve the conventional problem of a partially, or fully, closed contact hole, and restrain increase in the parasitic capacitance in an interlayer insulation layer due to an increase in the dielectric constant thereof through the use of an etching stopper layer. To achieve this, a first interlayer insulation layer is formed on a semiconductor substrate on which a first conductive pattern is formed. Next, the etching stopper pattern having an etching selection ratio with respect to the first interlayer insulation layer is partially formed in a particular area. Thereafter, a second interlayer insulation layer and a second conductive layer made of copper are formed.

(73) Assignee: **Samsung Electronics Co., LTD**

(21) Appl. No.: **09/780,830**

(22) Filed: **Feb. 9, 2001**

(30) **Foreign Application Priority Data**

Jul. 25, 2000 (KR) 00-42750

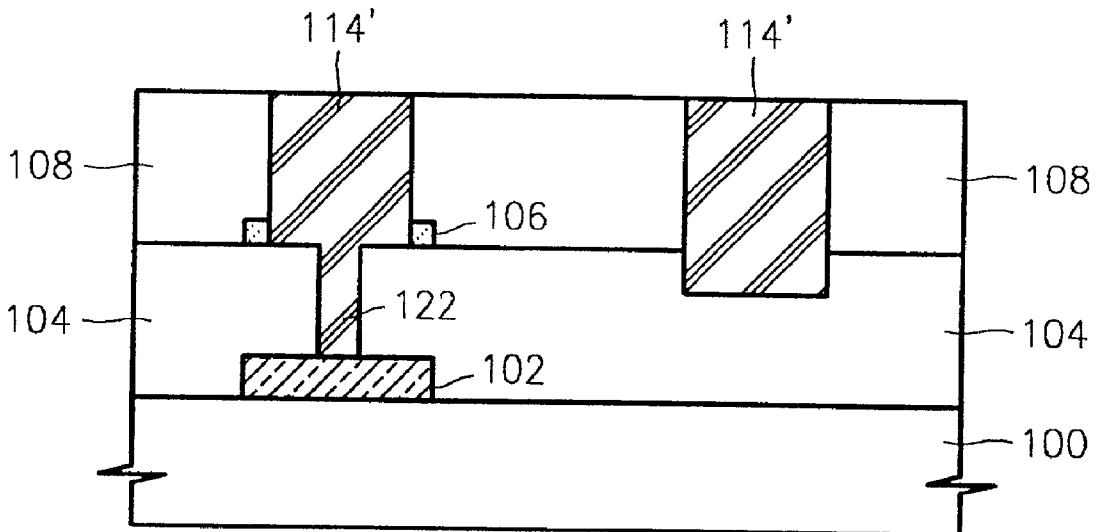

FIG. 1 (PRIOR ART)

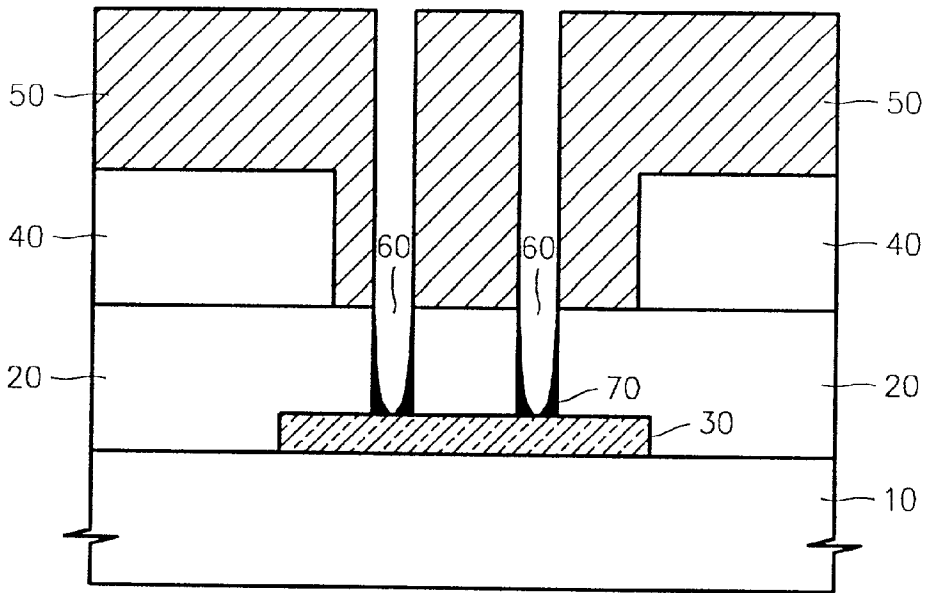

FIG. 2 (PRIOR ART)

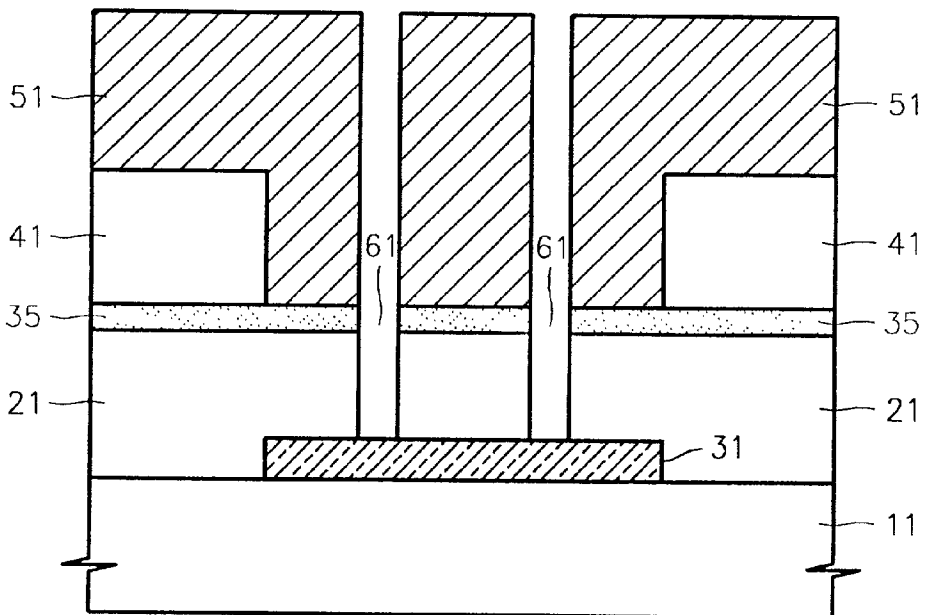

FIG. 3

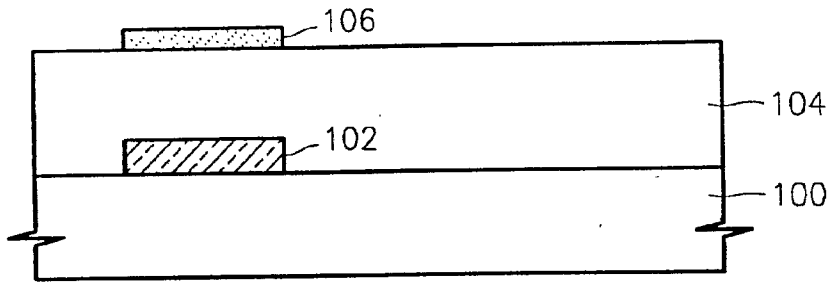

FIG. 4

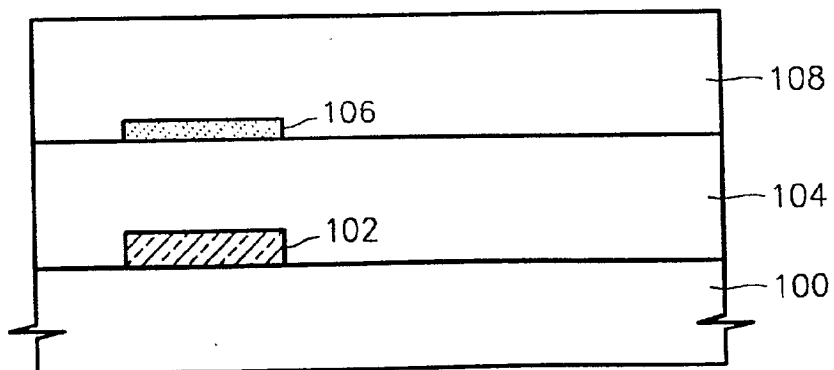

FIG. 5

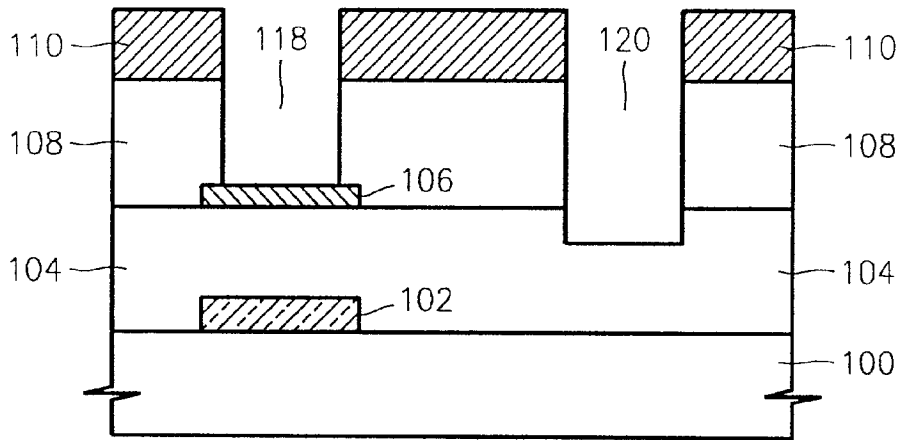

FIG. 6

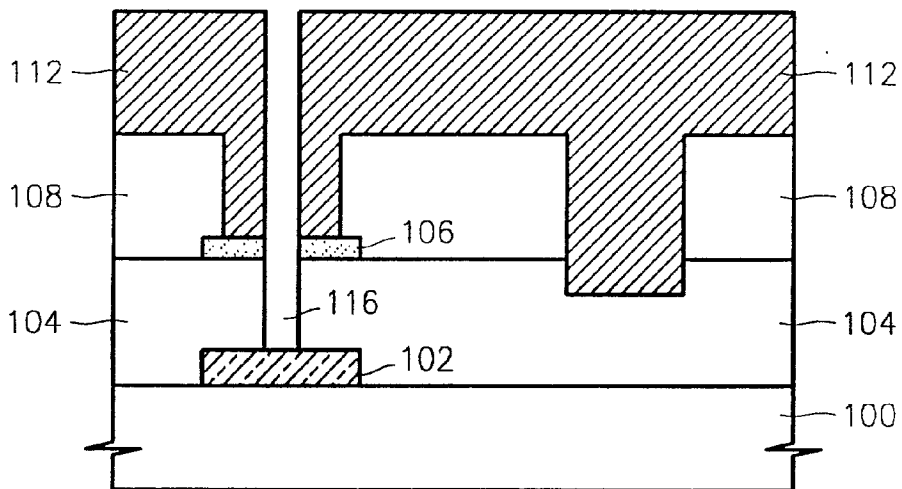

FIG. 7

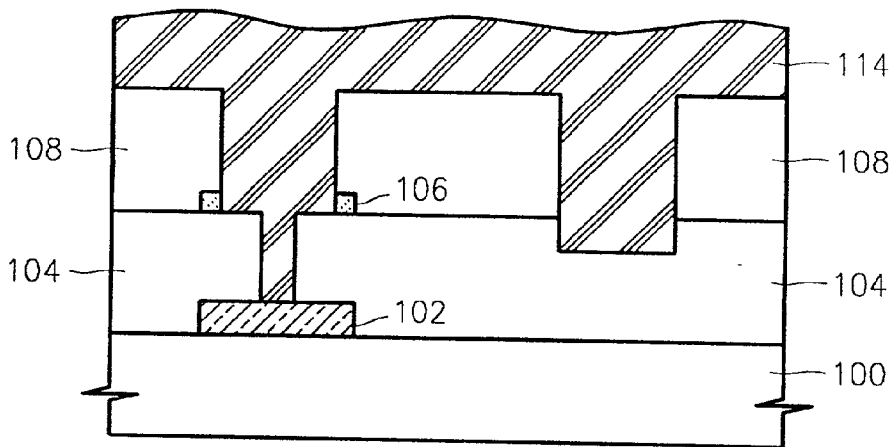

FIG. 8

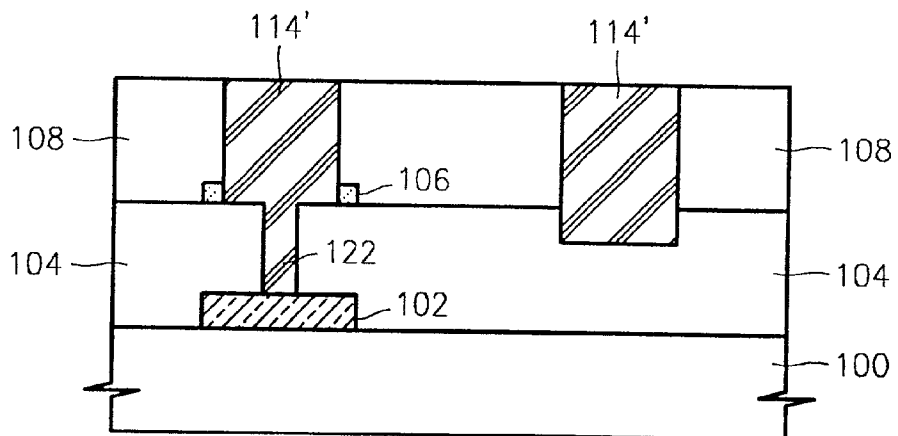

FIG. 9

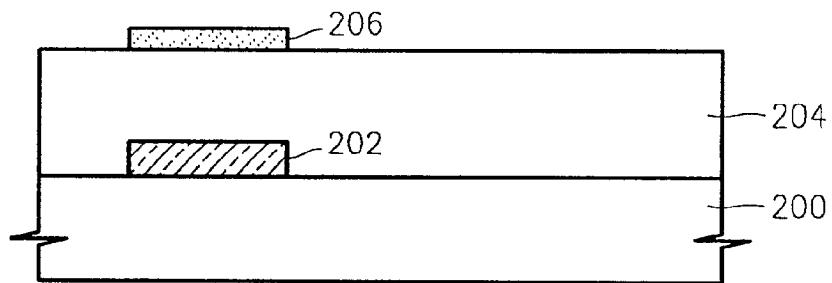

FIG. 10

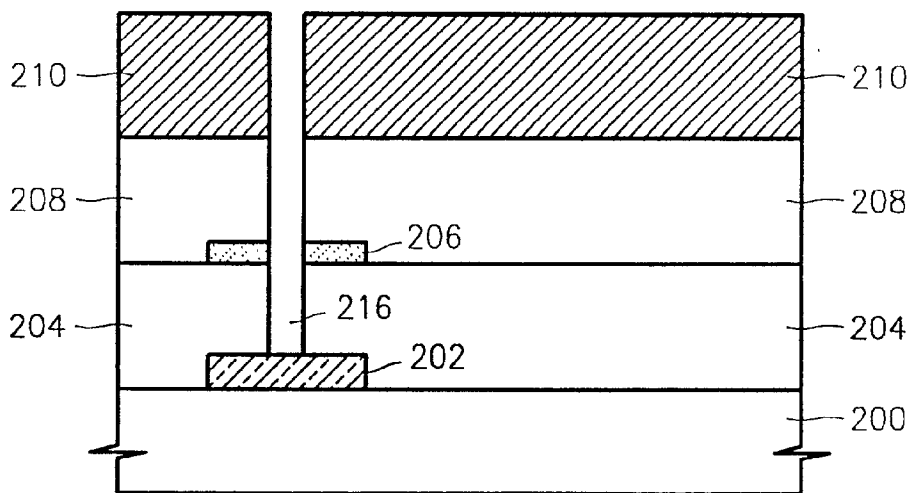

FIG. 11

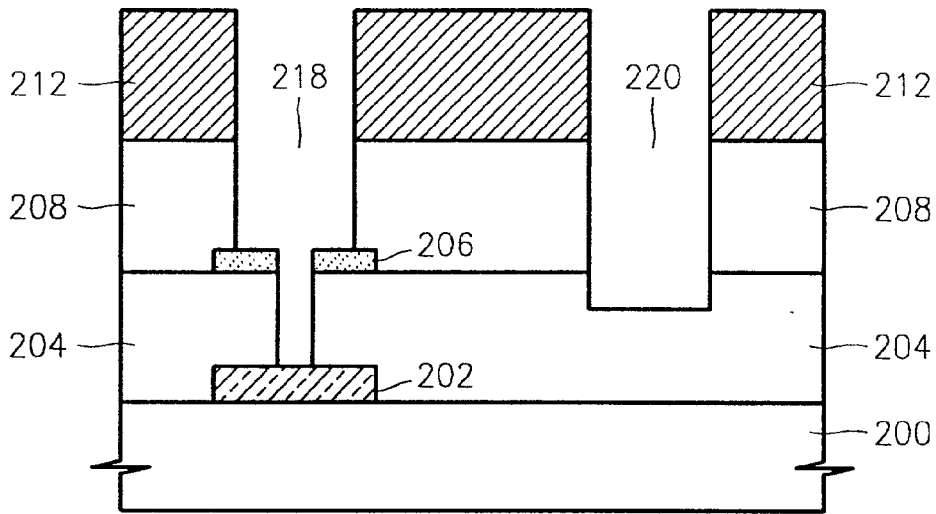

FIG. 12

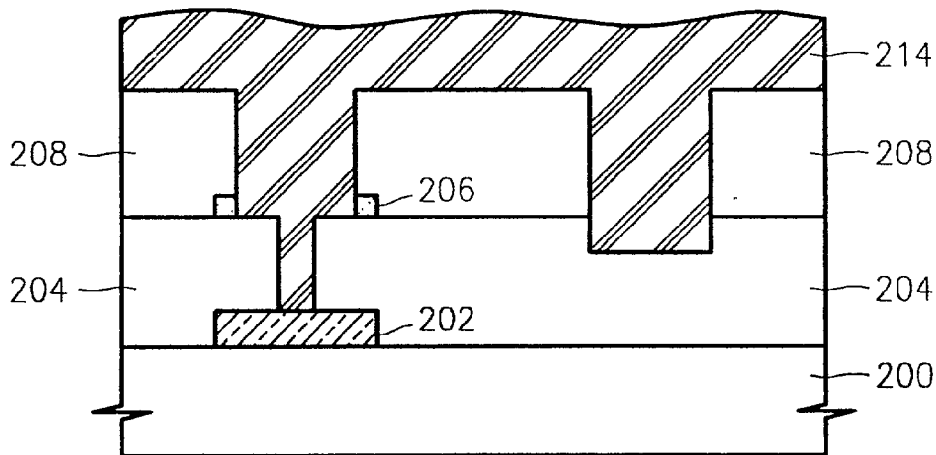

FIG. 13

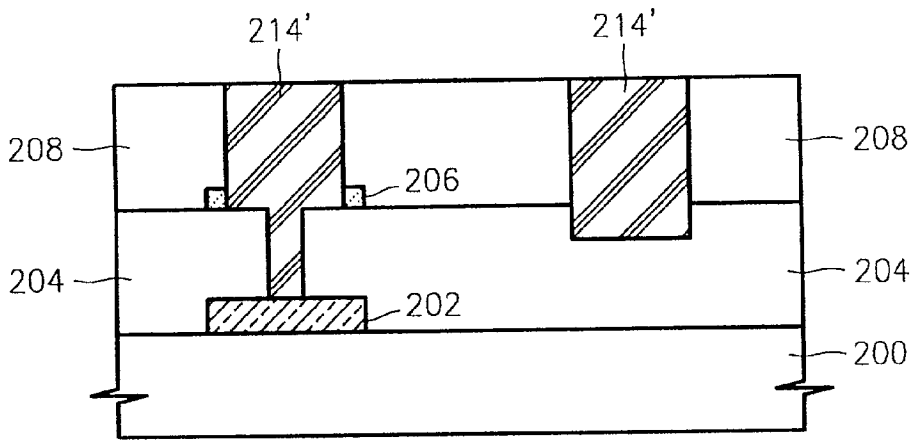

FIG. 14

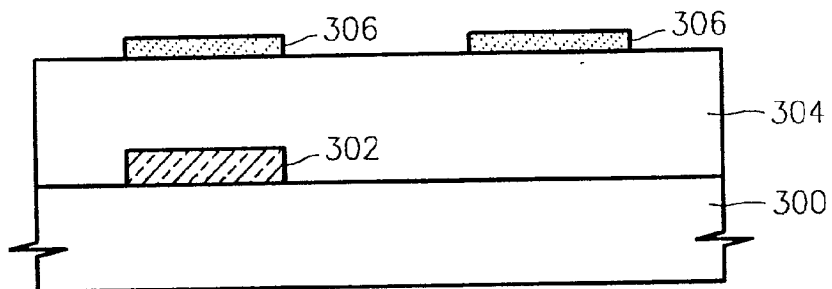

FIG. 15

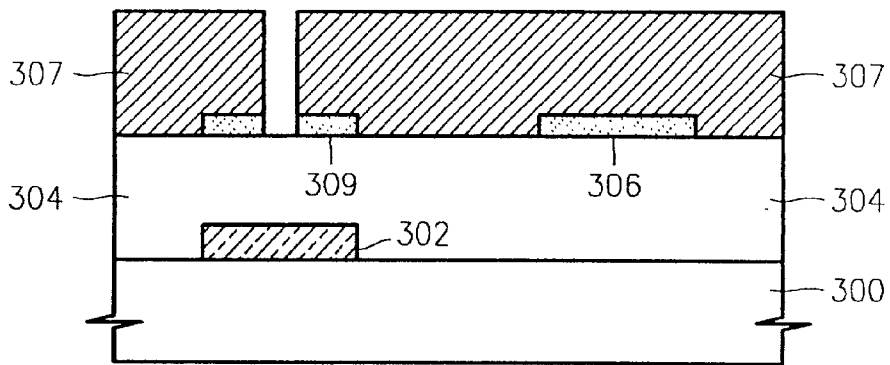

FIG. 16

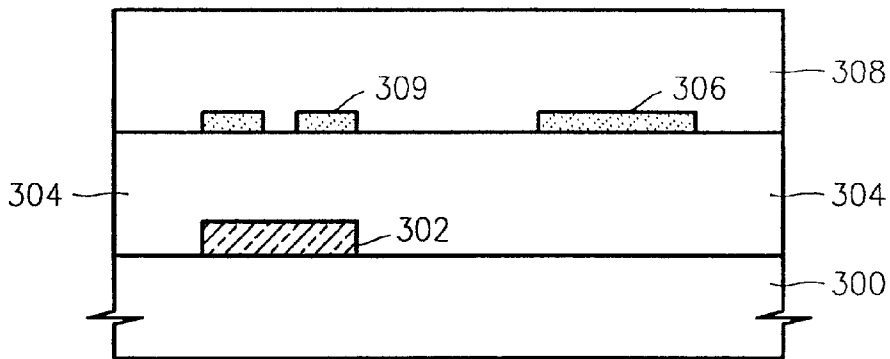

FIG. 17

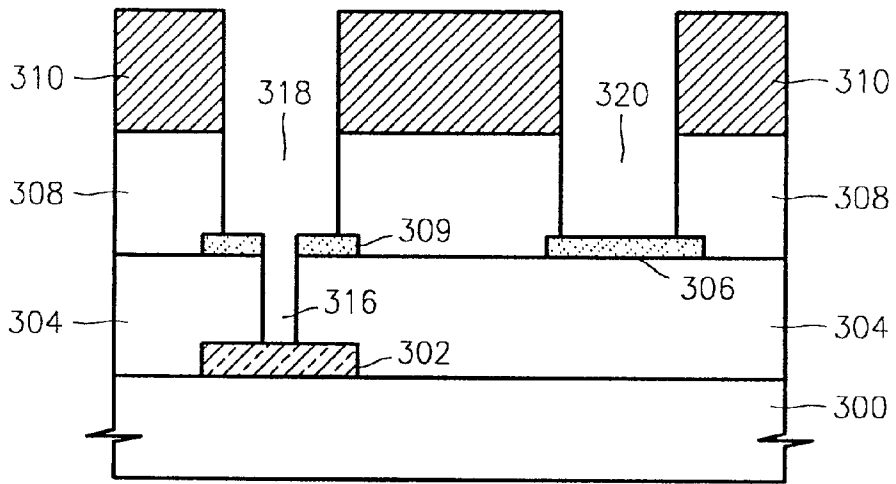
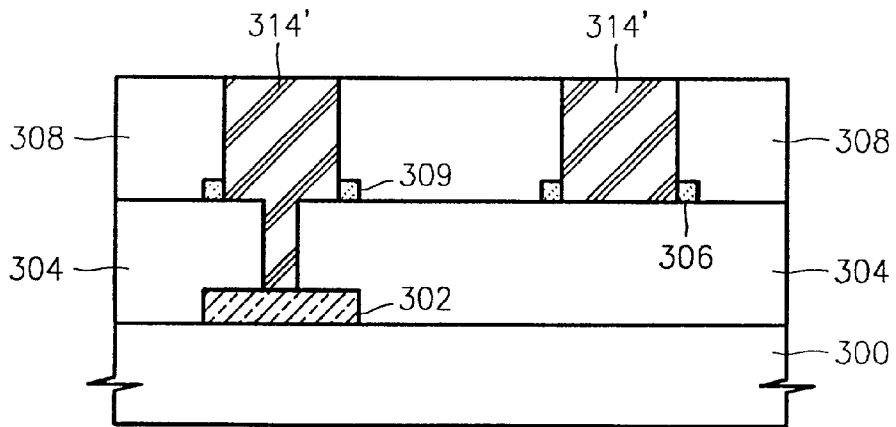

FIG. 18



SEMICONDUCTOR DEVICE HAVING DUAL DAMASCENE LINE STRUCTURE AND METHOD FOR FABRICATING THE SAME

BACKGROUND OF THE INVENTION

[0001] 1. Field of the Invention

[0002] The present invention relates to a semiconductor device and a method for fabricating the same, and more particularly, to a semiconductor device having a dual damascene line structure and a method for fabricating the same.

[0003] 2. Description of the Related Art

[0004] A damascene or inlay technique is an old technique for ornamenting craftworks. In this technique, various patterns are engraved on the surface of metal, ceramics or wood, and then a different material such as gold, silver or mother-of-pearl is inserted into the engraved portion.

[0005] Such a damascene technique has lately attracted attention as a new method of forming a metal line during the fabrication of semiconductor devices. In particular, since IBM Corporation announced that they applied a copper wiring process using a dual damascene technique to the fabrication of semiconductor devices in 1997, a variety of research has been carried out on the copper wiring process using the damascene technique focusing on logic devices.

[0006] Generally, it is difficult to dry-etch a copper line since the vapor pressure of by-products is low during a dry etching process, and the copper line is especially subject to corrosion such that it is difficult to use the copper line for a metal line in a semiconductor device.

[0007] However, the formation of a copper line becomes possible by using the damascene technique and a chemical mechanical polishing (CMP) process, instead of using dry-etching. Usually, a copper line has lower resistance than other existing metal lines and excellent electro-migration properties. In addition, a copper line allows the number of steps of forming a metal line in a semiconductor device to be reduced so that the fabrication cost can be reduced.

[0008] FIGS. 1 and 2 are sectional views illustrating conventional methods of forming a dual damascene line in a semiconductor device.

[0009] Referring to FIG. 1, a first conductive pattern 30 is formed on a semiconductor substrate 10, and then a first interlayer insulation layer 20 is formed. A second interlayer insulation layer 40 is formed on the first interlayer insulation layer 20. Subsequently, photolithography is performed to form a second interlayer insulation layer 40 pattern exposing a portion of the first interlayer insulation layer 20. Finally, a photoresist pattern 50 is formed on the semiconductor substrate 10 having the second interlayer insulation layer 40 pattern, and then an etching process is performed, thereby forming via contact holes 60 exposing the first conductive pattern 30.

[0010] However, in the conventional method of forming a damascene line in a semiconductor device described above, when an aspect ratio is large during dry etching for forming a via contact hole, the bottom of the via contact hole is not completely opened (70) due to the influence of a resulting etching slope and by-products. This problem becomes more severe as the integration density of semiconductor devices

increases. To solve this problem, an etching stopper layer is provided between the first interlayer insulation layer and the second interlayer insulation layer.

[0011] Referring to FIG. 2, a first conductive pattern 31, a first interlayer insulation layer 21, a second interlayer insulation layer 41 and a photoresist pattern 51 are formed on a semiconductor substrate 11 in the same manner as used in FIG. 1. An etching stopper 35 is further formed between the first interlayer insulation layer 21 and the second interlayer insulation layer 41 using a silicon nitride (SiN) layer.

[0012] This method solves the problem of the bottom of a via contact hole 61 not being opened by performing over-etching using the etching stopper 35; however, a nitride layer, i.e., the etching stopper 35, having a high dielectric constant should be formed between the interlayer insulation layers. When a material having a high dielectric constant is used between the interlayer insulation layers, parasitic capacitance in the interlayer insulation layers increases, thereby increasing RC delay during operation of the semiconductor device.

SUMMARY OF THE INVENTION

[0013] To address the above limitations, it is an object of the present invention to provide a semiconductor device having a dual damascene line structure that solves the aforementioned problem of the bottom of a via contact hole not being opened by using an etching stopper, and for reducing the parasitic capacitance of an interlayer insulation layer.

[0014] It is another object of the present invention to provide a method for fabricating a semiconductor device having the dual damascene line structure.

[0015] Accordingly, to achieve the first object of the invention, there is provided a semiconductor device having a dual damascene line structure. The semiconductor device includes a semiconductor substrate, a first conductive pattern formed on the semiconductor substrate, a first interlayer insulation layer covering the top of the first conductive pattern, an etching stopper pattern locally formed on the first interlayer insulation layer, a via contact plug formed within the first interlayer insulation layer in an area where the etching stopper pattern is formed such that the via contact plug is connected to the first conductive pattern, a second interlayer insulation layer formed on the etching stopper pattern, and a metal contact plug formed within the second interlayer insulation layer in an area where the etching stopper pattern is formed, wherein a portion of the etching stopper pattern is etched, and thus the metal contact plug is connected to the via contact plug.

[0016] The area of the locally formed etching stopper pattern is preferably wider than the area of the bottom of the metal contact plug.

[0017] To achieve the second object of the invention, in one embodiment, there is provided a method for fabricating a semiconductor device having a dual damascene line structure. In the method, a first interlayer insulation layer is formed on a semiconductor substrate on which a first conductive pattern has been formed. An etching stopper is formed on the first interlayer insulation layer. An etching stopper pattern is formed by patterning the etching stopper. A second interlayer insulation layer is deposited on the

semiconductor substrate on which the etching stopper pattern has been formed. The second interlayer insulation layer is patterned, thereby forming a first metal trench exposing the etching stopper pattern and a second metal trench where, as well as the second interlayer insulation layer, a portion of the first interlayer insulation layer is etched. Photolithography is performed on the semiconductor substrate, thereby forming a via contact hole exposing the first conductive pattern in an area corresponding to the first metal trench. A second conductive layer is formed to cover the surface of the semiconductor substrate so that the second conductive layer fills the first metal trench, the second metal trench and the via contact hole. The second conductive layer may be planarized using a chemical mechanical polishing method.

[0018] In another embodiment, there is provided a method for fabricating a semiconductor device having a dual damascene line structure. In this method, a first interlayer insulation layer is formed on a semiconductor substrate on which a first conductive pattern has been formed. An etching stopper is formed on the first interlayer insulation layer. An etching stopper pattern is formed by patterning the etching stopper. A second interlayer insulation layer is deposited on the semiconductor substrate on which the etching stopper pattern has been formed. Photolithography is performed on the semiconductor substrate, thereby forming a via contact hole exposing the first conductive pattern. The second interlayer insulation layer is patterned, thereby forming a first metal trench exposing the etching stopper pattern and a second metal trench where, as well as the second interlayer insulation layer, a portion of the first interlayer insulation layer is etched. A second conductive layer is formed to cover the surface of the semiconductor substrate so that the second conductive layer fills the first metal trench, the second metal trench and the via contact hole. The second conductive layer is optionally planarized by a chemical mechanical polishing method.

[0019] In still another embodiment, there is provided a method for fabricating a semiconductor device having a dual damascene line structure. In this method, a first interlayer insulation layer is formed on a semiconductor substrate on which a first conductive pattern has been formed. An etching stopper is formed on the first interlayer insulation layer. First etching stopper patterns are formed by patterning the etching stopper. Photolithography is performed on one of the first etching stopper patterns, thereby forming a second etching stopper pattern allowing a via contact hole to be formed in a self-aligning manner in a later step. A second interlayer insulation layer is deposited on the semiconductor substrate on which the second etching stopper pattern has been formed. Photolithography is performed on the second interlayer insulation layer, thereby forming a first metal trench exposing the second etching stopper pattern and thus forming a self-aligned via contact hole exposing the first conductive pattern, and forming a second metal trench where etching is stopped by another first etching stopper pattern. A second conductive layer is formed to cover the surface of the semiconductor substrate so that the second conductive layer fills the first metal trench, the second metal trench and the via contact hole. The second conductive layer is optionally planarized by a chemical mechanical polishing method.

[0020] The second conductive layer is preferably formed of copper. The etching stopper may be formed of a material having a lower etching rate than the first interlayer insulation

layer and is preferably formed of a material selected from the group consisting of SiN, SiC and SiO₂. The etching stopper pattern may be wider than the first metal trench.

[0021] The method preferably further includes the step of forming a layer for improving adhesion or preventing diffusion in the first metal trench, the second metal trench and the via contact hole, before depositing the second conductive layer.

[0022] According to the present invention, by locally using an etching stopper pattern in a particular region, the problem of the bottom of a via contact hole being partially opened, or blocked, following its formation, through etching, is solved. In addition, an increase in the dielectric constant of an interlayer insulation layer is restrained due to localized formation, thereby minimizing increase in the parasitic capacitance of the interlayer insulation layer.

BRIEF DESCRIPTION OF THE DRAWINGS

[0023] The above objectives and advantages of the present invention will become more apparent by describing in detail preferred embodiments thereof with reference to the attached drawings in which:

[0024] **FIGS. 1 and 2** are sectional views illustrating conventional methods of forming a dual damascene line in a semiconductor device;

[0025] **FIGS. 3 through 8** are sectional views illustrating a method of forming a dual damascene line in a semiconductor device according to a first embodiment of the present invention;

[0026] **FIGS. 9 through 13** are sectional views illustrating a method of forming a dual damascene line in a semiconductor device according to a second embodiment of the present invention; and

[0027] **FIGS. 14 through 18** are sectional views illustrating a method of forming a dual damascene line in a semiconductor device according to a third embodiment of the present invention.

DETAILED DESCRIPTION OF PREFERRED EMBODIMENTS

[0028] Hereinafter, preferred embodiments of the present invention will be described in detail with reference to the attached drawings.

[0029] Firstly, a semiconductor device having a dual damascene line structure according to the present invention will be fully described with reference to **FIG. 8**. The semiconductor device includes a semiconductor substrate **100**, a first conductive pattern **102** formed on the semiconductor substrate **100**, a first interlayer insulation layer **104** covering the surface of the first conductive pattern **102**, an etching stopper pattern **106** locally formed on the first interlayer insulation layer **104**, a via contact plug **122** formed in the area of the first interlayer insulation layer **104** corresponding to the etching stopper pattern **106** and connecting to the first conductive pattern **102**, a second interlayer insulation layer **108** formed on the etching stopper pattern **106** and the first interlayer insulation layer **104**, and a metal contact plug **114'** formed in the area of the second interlayer insulation layer **108** corresponding to the etching

stopper layer pattern **106** by etching a portion of the etching stopper pattern **106** and connecting to the via contact plug **122**.

[0030] In the configuration of a semiconductor device having such a dual damascene line structure, the etching stopper pattern **106** is important toward achieving the objectives of the present invention. Since the etching stopper pattern **106** is used as an etching stopper when etching is performed to form a via contact hole for forming the via contact plug **122**, the problem of a closed via contact hole bottom can be solved.

[0031] In addition, the etching stopper pattern **106** is formed to have a width that is $0.05\ \mu\text{m}$ larger than the width of the bottom of a metal trench for forming the metal contact plug **114'**. Accordingly, the etching stopper pattern **106** is locally formed only in a particular area, that is, localized to an area where the metal trench and the via contact hole are formed. Therefore, any increase in parasitic capacitance due to material having a high dielectric constant used between interlayer insulation layers is mitigated.

[0032] A method for fabricating a semiconductor device having a dual damascene line structure according to the present invention will be described by explaining three embodiments.

[0033] First Embodiment: Case of Forming a Trench First in Forming a Dual Damascene Line

[0034] FIGS. 3 through 8 are sectional views illustrating a method of forming a dual damascene line in a semiconductor device according to a first embodiment of the present invention.

[0035] Referring to FIG. 3, a first interlayer insulation layer **104** is formed on a semiconductor substrate **100** on which a first conductive pattern **102** is formed. The first interlayer insulation layer **104** is preferably an oxide-based insulation layer. Subsequently, an etching stopper is formed on the first interlayer insulation layer **104** to a thickness of $500\text{-}1000\ \text{\AA}$. The etching stopper is preferably an insulation layer having a lower etching rate than the first interlayer insulation layer **104**. The etching stopper is preferably formed of SiN, SiC or SiO₂.

[0036] Thereafter, photolithography is performed on the etching stopper to locally form an etching stopper pattern **106** in a particular area. The area where the etching stopper pattern **106** is formed corresponds to an area where a first metal trench and a via contact hole will be formed in subsequent processes.

[0037] Referring to FIG. 4, a second interlayer insulation layer **108** is formed on the semiconductor substrate **100** having the etching stopper pattern **106**, to an adequate thickness. The second interlayer insulation layer **108** is preferably formed of an oxide-based material having an etching rate similar to, or equal to, that of the first interlayer insulation layer **104**.

[0038] Referring to FIG. 5, a photoresist pattern **110** is formed on the second interlayer insulation layer **108**, and then etching is performed. The etching is stopped by the etching stopper pattern **106** in the area where a first metal trench **118** is formed, but the second interlayer insulation layer **108** and a portion of the first interlayer insulation layer

104 are etched in an area where a second metal trench **120** is formed without the etching stopper pattern **106**.

[0039] In this case, the etching stopper pattern **106** for stopping etching in the area of the first metal trench **118** functions properly only when the width of the etching stopper pattern **106** is larger than the width of the first metal trench **118**. To preferably reduce the width of the etching stopper pattern **106** having a high dielectric constant, the width of the etching stopper pattern **106** is preferably on the order of, for example, $0.05\ \mu\text{m}$ larger than that of the first metal trench **118**.

[0040] Referring to FIG. 6, the photoresist pattern **110** is removed, and another photoresist pattern **112** is formed. A via contact hole **116** exposing a portion of the first conductive pattern **102** is formed using the photoresist pattern **112**.

[0041] Here, since the first metal trench has already been formed using the etching stopper pattern **106**, the depth at which etching for forming the via contact hole begins is lower than that in the conventional art by the depth of the first metal trench. Accordingly, the aforementioned limitation of the conventional approach in that the bottom of the via contact hole **116** may be closed due to the long depth thereof is addressed by the present invention.

[0042] Referring to FIG. 7, the photoresist pattern **112** is removed, and the portion of the etching stopper pattern **106** exposed on the bottom of the first metal trench is removed by wet etching. Thereafter, a layer (not shown) for restraining diffusion or increasing an adhesive strength between oxide-based layers such as the first interlayer insulation layer **104** and the second interlayer insulation layer **108**, which are exposed along the surface of the semiconductor substrate **100**, and a copper line formed in a later process, may be formed on the semiconductor substrate **100** by a blanket method. This layer may be a single layer formed of TiN, Ta or TaN or a multilayer including one of these.

[0043] Thereafter, a first conductive layer **114** such as a copper layer is formed adequately on the semiconductor substrate **100** so that it fills the via contact hole and the first and the second metal trenches. The copper layer is formed by forming a copper seed layer using a physical vapor deposition method or a chemical vapor deposition method and performing electroplating on the seed layer. Accordingly, the formation of voids in the via contact hole, the first metal trench and the second metal trench can be restricted, and fabrication time can be reduced.

[0044] Referring to FIG. 8, the surface of the semiconductor substrate **100** having the first conductive layer **114** formed of copper is etched back by chemical mechanical polishing, thereby exposing the surface of the second interlayer insulation layer **108**. As a result, a second conductive pattern **114'** is formed. Therefore, the second conductive pattern **114'** in the area where the first metal trench is formed, that is, in the area where the via contact hole is connected, is thinner than the thickness of the second conductive pattern **114'** in the area where the second metal trench is formed.

[0045] Second Embodiment: Case of Forming a Via Contact Hole First in Forming a Dual Damascene Line

[0046] In the second embodiment, the order of the steps in the first embodiment is modified. Descriptions of the second

embodiment that are the same as the first embodiment will be omitted. **FIGS. 9 through 13** are sectional views illustrating a method of forming a dual damascene line in a semiconductor device according to the second embodiment of the present invention.

[0047] Referring to **FIG. 9**, a first conductive pattern **202** is formed on a semiconductor substrate **200**, and then a first interlayer insulation layer **204** is formed. An etching stopper pattern **206** is formed of SiN, SiC or SiO₂ on the first interlayer insulation layer **204**.

[0048] Referring to **FIG. 10**, a second interlayer insulation layer **208** is formed on the semiconductor substrate **200** having the etching stopper pattern **206**. Thereafter, a photoresist pattern **210** is formed, and then etching is performed, thereby forming a via contact hole **216** exposing a portion of the first conductive pattern **202**.

[0049] Referring to **FIG. 11**, the photoresist pattern **210** is removed, and then another photoresist pattern **212** used for forming a first metal trench **218** and a second metal trench **220** is formed on the second interlayer insulation layer **208**. Subsequently, the underlying layers are etched using the photoresist pattern **212**.

[0050] Here, in an area where the first metal trench **218** is formed, the etching is stopped before the first interlayer insulation layer **204** by the etching stopper pattern **206** formed in a particular area according to the present invention. However, in an area where the second metal trench **220** is formed, the etching is continued into a portion of the first interlayer insulation layer **204** because an etching stopper pattern does not exist in that region.

[0051] Referring to **FIG. 12**, the photoresist pattern **212** is removed, and then the portion of the etching stopper pattern **206** exposed in the area of the first metal trench **218** is removed by dry etching. A layer (not shown) for improving the adhesive strength or preventing diffusion may be formed on the exposed surface of the semiconductor substrate **200** by a blanket method. Thereafter, a copper layer corresponding to a first conductive layer **214** is formed on the entire surface of the semiconductor substrate **200** so that it fills the via contact hole, the first metal trench and the second metal trench.

[0052] Referring to **FIG. 13**, a chemical mechanical polishing process is performed on the semiconductor substrate **200** having the first conductive layer **214** until the surface of the second interlayer insulation layer **208** is exposed. As a result, second conductive patterns **214'** are formed in the first and the second metal trenches.

[0053] Third Embodiment: Case of Forming a Via Contact Hole in a Self-Aligning Manner in Forming a Dual Damascene Line

[0054] In a third embodiment, the order of the steps for forming a via contact hole in the first embodiment is modified. Descriptions of the third embodiment that are the same as the first embodiment will be omitted. **FIGS. 14 through 18** are sectional views illustrating a method of forming a dual damascene line in a semiconductor device according to the third embodiment of the present invention.

[0055] Referring to **FIG. 14**, a first conductive pattern **302** is formed on a semiconductor substrate **300**, and then a first interlayer insulation layer **304** is formed. A first etching

stopper pattern **306** is formed of SiN, SiC or SiO₂ on the first interlayer insulation layer **304**. Unlike the first and second embodiments, the first etching stopper pattern **306** is formed not only in an area where a first metal trench will be formed, but also in an area where a second metal trench will be formed.

[0056] Referring to **FIGS. 15 and 16**, a first etching stopper pattern **306** formed in the area where the first metal trench will be formed is patterned using a photoresist pattern **307**, along with a second etching stopper pattern **309**. A via contact hole is formed in the second etching stopper pattern **307**, as shown. A second interlayer insulation layer **308** is formed on the semiconductor substrate **300** having the first and second etching stopper patterns **306, 309**.

[0057] Referring to **FIG. 17**, another photoresist pattern **310** is formed on the semiconductor substrate **300** having the second interlayer insulation layer **308**, and then etching is performed to form a first metal trench **318** and a second metal trench **320**. Here, in the area of the first metal trench **318**, self-aligned etching is continued due to the shape of the second etching stopper pattern **309** after the etching of the second interlayer insulation layer **308** is completed.

[0058] Progress of the self-aligned etching due to the opening in the second etching stopper pattern **309** forms a via contact hole **316**, thereby exposing a portion of the surface of the first conductive pattern **302**. Meanwhile, in the area of the second metal trench **320**, the etching is stopped by the first etching stopper pattern **306** so that the underlying first interlayer insulation layer **304** is not etched.

[0059] Referring to **FIG. 18**, the photoresist pattern **310** is removed, and the portions of the first and second etching stopper patterns **306** and **309** exposed by the first and second metal trenches **318** and **320** are removed. Subsequently, a layer (not shown) for improving the adhesive strength and/or preventing diffusion is formed within the first and second metal trenches by a blanket method.

[0060] Thereafter, a second conductive layer is formed of copper on the resultant structure. The second conductive layer fills the via contact hole, the first metal trench and the second metal trench. Finally, a chemical mechanical polishing process is performed on the second conductive layer to expose the surface of the second interlayer insulation layer **308**, thereby forming second conductive patterns **314'**.

[0061] Accordingly, by locally using an etching stopper pattern in a particular area, the present invention addresses the limitation of the bottom of a via contact hole being partially, or fully, closed following formation of the via contact hole through etching. In addition, through localization of the etching stopper pattern, the present invention mitigates an increase in the dielectric constant of an interlayer insulation layer arising from the etching stopper pattern, thereby minimizing an increase in the parasitic capacitance of the interlayer insulation layer.

[0062] Although the invention has been described with reference to particular embodiments, it will be apparent to one of ordinary skill in the art that modifications of the described embodiments may be made without departing from the spirit and scope of the invention.

What is claimed is:

1. A semiconductor device having a dual damascene line structure, the semiconductor device comprising:

- a semiconductor substrate;
- a first conductive pattern formed on the semiconductor substrate;
- a first interlayer insulation layer on the first conductive pattern;
- an etching stopper pattern locally formed above the first conductive pattern on the first interlayer insulation layer;
- a via contact plug formed in the first interlayer insulation layer in an area where the etching stopper pattern is formed such that the via contact plug is connected to the first conductive pattern;
- a second interlayer insulation layer formed on the etching stopper pattern and the first interlayer insulation layer; and
- a metal contact plug formed within the second interlayer insulation layer in an area where the etching stopper pattern is formed, the metal contact plug extending through the etching stopper pattern thereby contacting the via contact plug.

2. The semiconductor device of claim 1, wherein the area of the locally formed etching stopper pattern is wider than the area of the bottom of the metal contact plug.

3. A method for fabricating a semiconductor device having a dual damascene line structure, the method comprising the steps of:

- forming a first interlayer insulation layer on a semiconductor substrate on which a first conductive pattern has been formed;
- forming an etching stopper on the first interlayer insulation layer;
- forming an etching stopper pattern above the first conductive pattern by patterning the etching stopper;
- depositing a second interlayer insulation layer on the etching stopper pattern;
- patterning the second interlayer insulation layer, thereby forming a first metal trench exposing the etching stopper pattern, and thereby forming a second metal trench formed through the second interlayer insulation layer and a portion of the first interlayer insulation layer;
- providing a via contact hole exposing the first conductive pattern in an area corresponding to the first metal trench; and
- forming a second conductive layer in the first metal trench, the second metal trench and the via contact hole.

4. The method of claim 3, wherein the second conductive layer is formed of copper.

5. The method of claim 3, wherein the etching stopper is formed of a material having a lower etching rate than the first interlayer insulation layer.

6. The method of claim 5, wherein the material having the lower etching rate than the first interlayer insulation layer

comprises an insulation layer formed of a material selected from the group consisting of SiN, SiC and SiO₂.

7. The method of claim 3, wherein the thickness of the etching stopper pattern is 500-1000 Å.

8. The method of claim 3, wherein the etching stopper pattern is wider than the first metal trench.

9. The method of claim 3, further comprising the step of forming a layer for improving adhesion or preventing diffusion in the first metal trench, the second metal trench and the via contact hole, after forming the via contact hole.

10. A method for fabricating a semiconductor device having a dual damascene line structure, the method comprising the steps of:

- forming a first interlayer insulation layer on a semiconductor substrate on which a first conductive pattern has been formed;
- forming an etching stopper on the first interlayer insulation layer;
- forming an etching stopper pattern above the first conductive pattern by patterning the etching stopper;
- depositing a second interlayer insulation layer on the etching stopper pattern;
- providing a via contact hole through the second interlayer insulation layer, the etching stopper pattern, and the first interlayer insulation layer, thereby exposing the first conductive pattern;

patterning the second interlayer insulation layer, thereby forming a first metal trench exposing the etching stopper pattern, and thereby forming a second metal trench formed through the second interlayer insulation layer and a portion of the first interlayer insulation layer; and

forming a second conductive layer in the first metal trench, the second metal trench and the via contact hole.

11. The method of claim 10, wherein the second conductive layer is formed of copper.

12. The method of claim 10, wherein the etching stopper is formed of a material having a lower etching rate than the first interlayer insulation layer.

13. The method of claim 12, wherein the material having the lower etching rate than the first interlayer insulation layer comprises an insulation layer formed of a material selected from the group consisting of SiN, SiC and SiO₂.

14. The method of claim 10, wherein the thickness of the etching stopper pattern is 500-1000 Å.

15. The method of claim 10, wherein the etching stopper pattern is wider than the first metal trench.

16. The method of claim 10, further comprising the step of forming a layer for improving adhesion or preventing diffusion in the first metal trench, the second metal trench and the via contact hole, after forming the first and second metal trenches.

17. A method for fabricating a semiconductor device having a dual damascene line structure, the method comprising the steps of:

- forming a first interlayer insulation layer on a semiconductor substrate on which a first conductive pattern has been formed;
- forming an etching stopper on the first interlayer insulation layer;

forming first etching stopper patterns by patterning the etching stopper;

performing photolithography on at least one of the first etching stopper patterns, thereby forming a second etching stopper pattern including a self-aligning via contact hole;

depositing a second interlayer insulation layer on the first and second etching stopper patterns;

photolithographically etching a first metal trench in the second interlayer insulation layer, thereby exposing the second etching stopper pattern, thereby forming a self-aligned via contact hole exposing the first conductive pattern, and forming a second metal trench where etching is stopped by the first etching stopper pattern; and

forming a second conductive layer in the first metal trench, the second metal trench, and the via contact hole.

18. The method of claim 17, wherein the second conductive layer is formed of copper.

19. The method of claim 17, wherein the etching stopper is formed of a material having a lower etching rate than the first interlayer insulation layer.

20. The method of claim 19, wherein the material having the lower etching rate than the first interlayer insulation layer comprises an insulation layer formed of a material selected from the group consisting of SiN, SiC and SiO₂.

21. The method of claim 17, wherein the thickness of each of the etching stopper patterns is 500-1000 Å.

22. The method of claim 17, wherein the first etching stopper pattern is wider than the first metal trench.

23. The method of claim 17, further comprising the step of forming a layer for improving adhesion or preventing diffusion in the first metal trench, the second metal trench and the via contact hole, after forming the first metal trench, the second metal trench and the via contact hole.

* * * * *