

(19)
(12)

(KR)
(B1)

(51) 。 Int. Cl. ⁷
G01L 5/28

(45)
(11)
(24)

2002 05 08
10 - 0335895
2002 04 25

(21) 10 - 1999 - 0066714
(22) 1999 12 30

(65) 2001 - 0059322
(43) 2001 07 06

(73)

231

(72)

2

202 1503

(74)

:

(54)

가

;

가

;

;

;

가

.

1

, ,

1
2
3
4
5
6

(3)

(3)

(3)

가

(AC DYNOMETER)

(AC DYNOMETER)

가

가

가

+

가

가

가

가

가 , , .

가 ; ;

1 , (300,400) , (100) , (700) (In) (100) (100) (300,400) (500) (100) (600) (600) (700) (500) (601) (700) (700)

2 , / (10) ; (20) ; (30) ; (40) ; (50) ; (60) ; (70) ; (300,400) (81) ; (500) (82) ; (600) (700) (700) (200) (90) ()

3 , 4 , 6 , 5

3 가 (100) (10) (20) (100) 가 . 가 (20) 가 (S100), (100) 가 가 (S200).

가

가 /

가 , 4

(100)

(S210).

(100)

/

(300)

(400)

(300)

(400)

(100)

/

(301)

(401)

(301)

(401)

(450)

(300)

(400)

가

(100)

(700)

가

(30)

(40)

(S600),

(100)

(700)

(S700).

(700)

(100)

가

가

가

가

(S300).

(100)

가

가

/

가
(100)

가

, 5

(S310).

, (100) / (500) .

(500) (100) / (600) .

(600) (500) 가 (100) (

700) .

가 (30) (40) (S600),
(100) (700)
, (S700).

(700) (100) .

, 가 (100)

가 2 가 (S400).

가 2 가 , 6
(100) 2

(S410).

, (100) / (600) .

(600) (100) / (500) (

700) .

(500) (600) 가

(100) .

, 가 (30) (40) (S
600), (100) (700)

, (S700).

(700) (100) .

, 가 4 가 , 6
(100) 2

(S500).

, (100) / (600) .

(600) (100) / (500) (

700) .

(500) (600) 가

(100) .

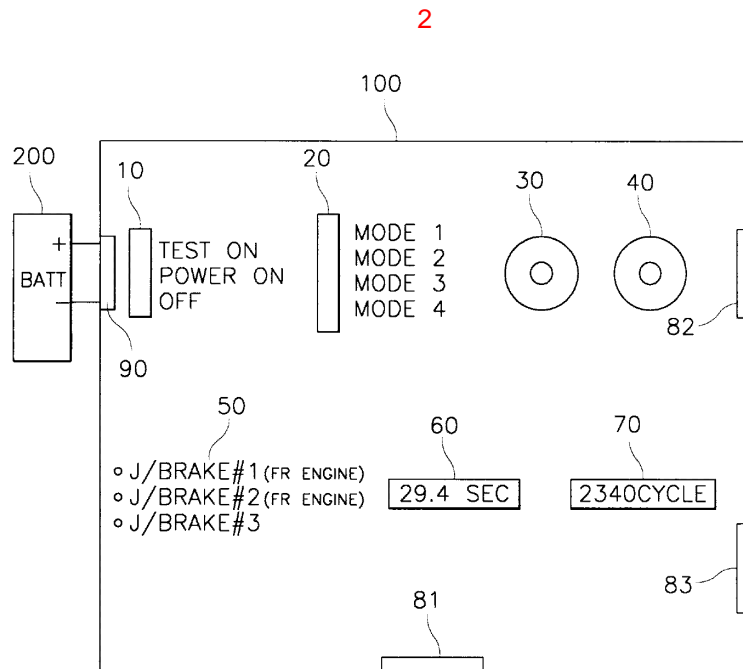
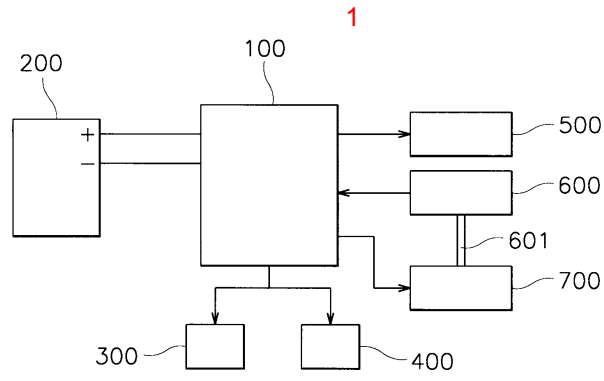

3

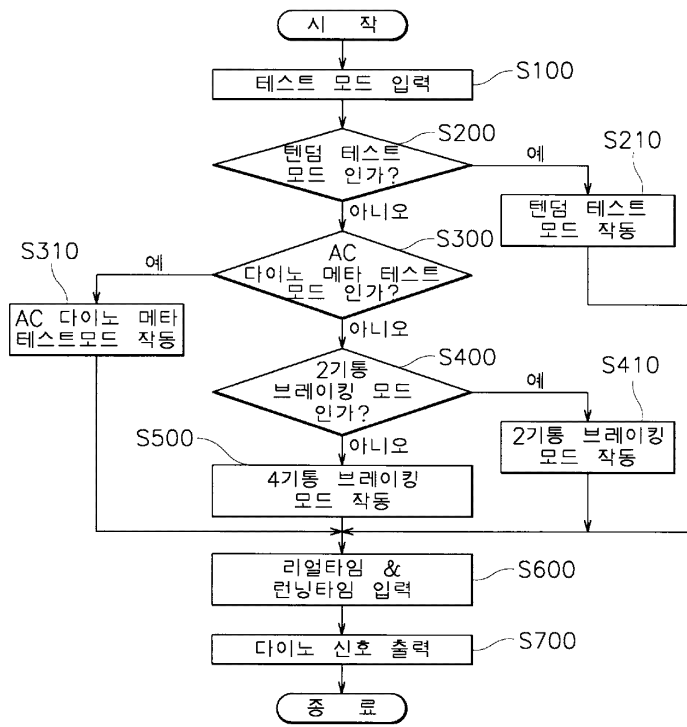

4

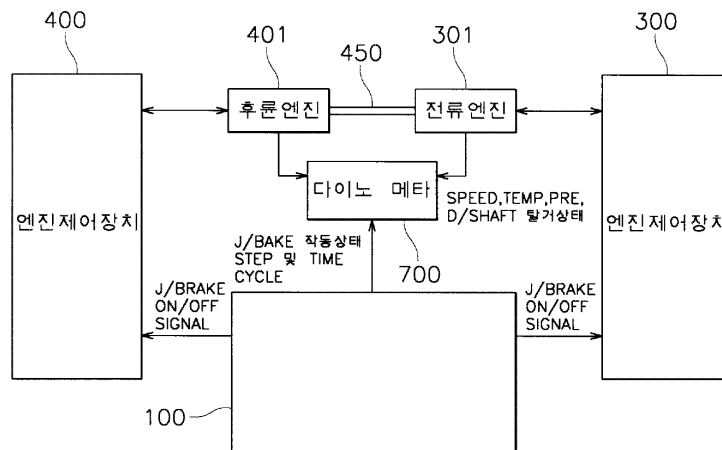

5

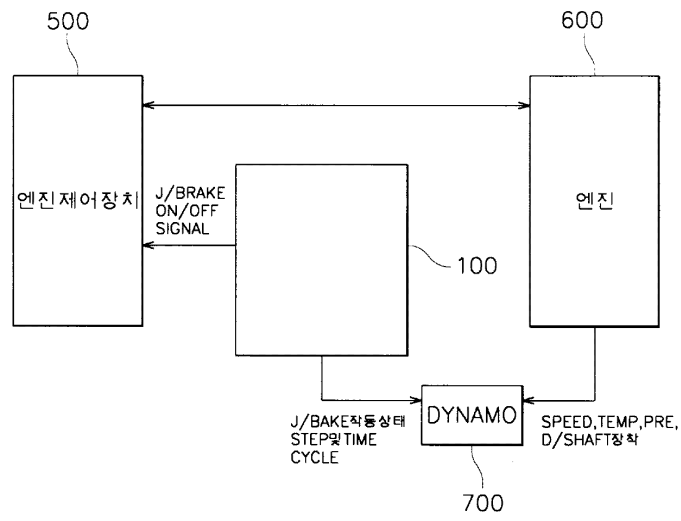

6

