

EUROPEAN PATENT APPLICATION

Application number: 83306736.6

Int. Cl.³: B 60 R 21/10

Date of filing: 04.11.83

Priority: 08.11.82 US 439895
13.05.83 US 494569

Applicant: GATEWAY INDUSTRIES INC.
17512 Carriageway Drive
Hazel Crest, IL 60429(US)

Date of publication of application:
11.07.84 Bulletin 84/28

Inventor: Doty, Gerald Alexander
12228 Hayes Street
Crown Point Indiana 46307(US)

Designated Contracting States:
DE FR GB SE

Representative: Bayliss, Geoffrey Cyril et al,
BOULT, WADE & TENNANT 27 Furnival Street
London EC4A 1PQ(GB)

Free-falling, self-locking adjustable tip assembly.

A free-falling, self-locking adjustable tip assembly in a safety belt apparatus includes a tongue plate (28) insertable into a buckle (30) and a continuous retractable belt length (15) providing both a lap (42) portion and a shoulder (44) portion. The tip assembly through which the belt passes has a snubber slide (60) engaged with the tongue plate (34) and slidable relative thereto. When the belt is drawn by the passenger over his body, the belt shifts the snubber (60) slide rearward on the tongue plate (34) to where the belt (42) is firmly gripped between a surface of the tongue plate a surface of the snubber slide, whereby that portion of the belt which extends across the passenger's lap cannot expend. When the belt is retracted so that a run of the belt is substantially vertical, the weight of the tip assembly (28) causes its front end to tip downward causing the slide to fall forward along the tongue plate (34) releasing its grip on the belt, whereby the tip assembly freely falls to a lower position along the vertical belt run. To prevent the belt from miscentering and twisting within the tip assembly, the snubber slide (60) has a pair of parallel tracks to guide the belt (44) through the tip assembly.

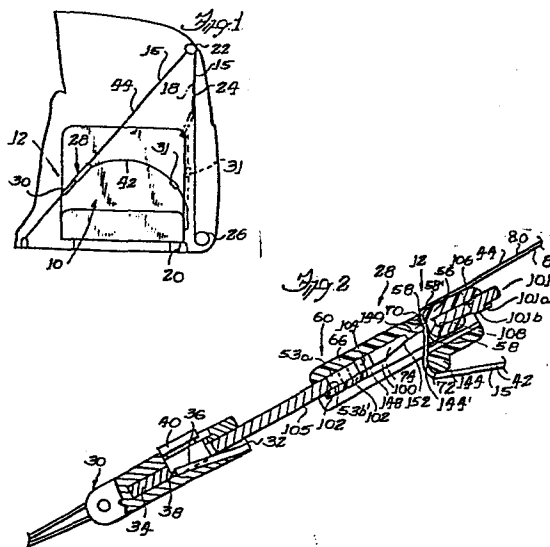

FREE-FALLING, SELF-LOCKING ADJUSTABLE TIP ASSEMBLY

This invention relates to a seat belt apparatus and to a slideable tip assembly on the seat belt which
5 has a tongue or tip for releasable connection to a buckle.

The present invention will be described in connection with its preferred usage in which a seat belt retractor is connected to one end of the belt and is
10 located adjacent a vehicle door, either on the floor or in the roof rail, to exert a tension or pulling force on its connected belt end. A tip assembly is carried on the belt and includes the tongue plate which the vehicle passenger grasps and inserts into locking engagement
15 with a seat belt buckle. The buckle is usually located inboard of and along the seat where the occupant is to sit. The other end of the belt is usually connected to an anchor. In this buckled configuration, the span of the belt from the tip assembly to the anchor defines a
20 lap belt portion extending over the lap of the seat occupant; while another portion of the belt extending upwardly from the tip assembly defines a shoulder-engaging portion extending across the chest and shoulder of the seat occupant to a hanger or the seat
25 belt retractor located above the passenger's shoulder.

If the slideable tip assembly is freely slideable on the lap belt it has a tendency to allow additional belt to pass from the shoulder portion into the lap portion during movement of the passenger. After
30 a time, such movements could result in the lap portion becoming loose on the passenger's lap. This condition is undesirable as it could happen that the passenger could possibly slide under the lap portion in what is called a "submarine" movement.

This invention provides in a safety belt apparatus, the combination comprising: a safety belt having a shoulder portion and a lap portion, a seat belt retractor connected to one end of the safety belt and pulling on the belt for rewinding the belt and for pulling a portion of the belt into a generally vertical position when the belt is released for full retraction, a tip assembly slidably mounted on the belt and having a tongue plate for connection to a buckle, and snubber means on the tip assembly shiftable by the tongue plate hanging downwardly and with the belt in the vertical position to allow free sliding of the tip assembly downwardly along the belt, said snubber means being shifted to a belt gripping position by the belt under tension from the retractor when the tongue plate is connected to the buckle.

The above arrangement permits the lap-engaging span of the seat belt to be reasonably tight in use and incapable of being extended without releasing the tip assembly and rebuckling it so that the occupant in the seat is secure by held should an accident occur. On the other hand the shoulder-engaging span of the belt webbing may be allowed to be slightly loose to allow the occupant to move forward in the seat freely while yet not being outside the protective confinement of the seat belt apparatus.

In a further feature of the invention the tip assembly may be located at a lower and more easily

accessible position near the seat for easy grasping by the user. Thus, it is preferred that the tip assembly be capable of freely sliding down the vertical belt portion to the desired location when
5 the belt is retracted.

The following is a detailed description of a specific embodiment of the invention, reference being made to the accompanying drawings in which:

FIGURE 1 is a schematic illustration of
10 seat belt apparatus showing the belt with the tip assembly thereon;

FIGURE 2 is an enlarged view of the tip assembly illustrated in FIGURE 1 in its buckled condition;

15 FIGURE 3 is a view similar to FIGURE 2, except that it illustrates the tip assembly in an unbuckled, stored condition;

FIGURE 4 is a perspective view of components, including a frame and a snubber slide, used to
20 form the tip assembly disclosed herein, the components being disassembled just prior to assembly;

FIGURE 5 is an elevation view of the snubber slide of FIGURE 4;

25 FIGURE 6 is an end view of the snubber slide of FIGURE 4, inverted from its FIGURE 2 and 3 orientation, with the seat belt shown in cross section; and

30 FIGURE 7 is a perspective view of the plastic insert that provides the slot liner shown in FIGURE 4.

As shown in the drawings for purposes of illustration, the invention is embodied in a seat belt apparatus 12 mounted in a vehicle having a seat 10 upon which the passenger will sit. A seat belt 15 is
5 connected at one end to a seat belt retractor 26 which is located outboard of the vehicle seat adjacent the vehicle door. Herein, the retractor is mounted on the floor but in other installations the retractor is
10 mounted at the vehicle roof rail in the general location where a turning loop 22 is located in the illustrated configuration. The seat belt 15 has a vertical run 24 between the retractor and the turning loop 22 over which the belt freely slides as the passenger grasps a tip assembly 28 on the belt and pulls the belt from the
15 retractor to connect the tip assembly 28 to a seat belt buckle 30. The belt portion extending between the turning loop 22 and a floor anchor 20 is divided into a lap portion 42 and a shoulder portion 44 by the tip assembly, as will be explained in greater detail.

20 In normal use of the illustrated seat belt apparatus 12 the occupant grasps the tip assembly 28 and moves it laterally away from the belt run 18 to cause the belt 15 to be extended by drawing the same off the retractor 26 until sufficient belt has been withdrawn
25 from the retractor to allow the tip assembly 28 to be engaged with the buckle 30. As best seen in FIGURE 2, the buckle 30 typically has a receiving opening 32 into which a tongue 34 formed on the tip assembly 28 is inserted, and a locking pawl 36 that is spring biased to a locking condition and is adapted to ride over the

tongue 34 and to snap into the locking opening 38 in the tongue 34 to thereby latch the tip assembly to its buckle. A release button 40 typically further is associated with the buckle to disengage the locking pawl 5 36 from the tongue opening 38 to release the tip assembly from confined securement with the buckle 30.

In the buckled condition, the lap-engaging span or portion 42 of the belt 15 is defined between the tip assembly 28 and a floor anchor or securing bracket 20; 10 and the shoulder-engaging span or portion 44 of the belt is defined between the tip assembly 28 and the turning loop 22.

In the preferred use of the seat belt apparatus illustrated herein, it is desirable to allow for the 15 tight securement of the lap-engaging portion 42 across the lap of the occupant, while yet allowing some looseness in the shoulder-engaging portion 44, thereby allowing the occupant some slight freedom of upper body movement. The looseness in the shoulder-engaging 20 portion 44 should not be allowed to work its way through the tip assembly 28 and ultimately allow the lap-engaging portion 42 to become loose. This is undesirable because if the vehicle suddenly stops, it is possible that the occupant could submarine under the 25 lap-engaging portion 42 of the belt and be injured.

In accordance with the present invention, the tip assembly 28 is mounted on the belt 15 so as to be automatically shifted between a free sliding position in which the tip assembly is freely slidable on the belt 30 run 18 when it is vertically disposed, as shown in dotted lines in FIGURE 1, and as shown in FIGURE 3 and a gripping position to grip the belt when the tip assembly is latched to the buckle 30, as shown in FIGS. 1 and 2. In the gripping position, the tension of the belt 15 35 causes a snubbing means on the tip assembly 28 to shift upwardly and rearwardly, i.e., upwardly and to the right as seen in FIG. 2, to bring a wall 70 on a snubber slide

60 and a wall 58 of the frame 50 together to pinch or grip the belt is in a nip therebetween, as shown in FIG. 2. The belt 15 passes through a slot 52 in a frame 50 and an opening 63 (FIGS. 4 and 6) in a snubber slide 60.

5 The orientation of the tongue 34 and its weight causes the tip assembly 28 to hang downwardly at the angle shown in FIG. 3 when the belt run 18 is vertical and the slot 52 in the tip body or frame 50 and the opening 63 in the slide 60 are aligned as shown in
10 FIG. 3 providing a vertical belt pathway through the tip assembly 28. Thus, the tip assembly 28 may freely slide down the belt run 18 from an upper position more closely adjacent the turning loop 22 to abut a stop 31 carried on the belt 15 to stop the tip assembly at the height of
15 the stop.

 In accordance with an important and further aspect of the invention, the tip assembly 28 is formed inexpensively with only the frame 50 and the snubber slide 60 constituting the operating parts. Although the
20 frame 50 could be formed as a unitary piece of stamped rigid material, such as steel, in the preferred embodiment, the frame consists of a rigid frame body 101 and a molded liner 100 (FIGURE 7) which is joined to the body by a snap fit and which is formed of material,
25 e.g., plastic, formed to provide smooth, sliding surfaces that relieve friction and wear as the belt webbing slides thereagainst. Alternatively, a liner 100 could be molded onto the body 101. After the liner 100 is snapped fitted onto the body 101, the tip assembly 28
30 is completed merely by sliding the slide 60 across the frame beginning at the front tip of the tongue 34 until a detent means 74 on the interior of the snubber slide 60, which is deflected during assembly, snaps into a channel 53a in the frame 50 and is positioned for
35 locking engagement with the frame 50.

 Turning now to a more detailed description of the invention, the tip assembly 28 includes the

elongated, generally planar tongue plate or frame body 101 which has a narrowed tongue 34 at its forward end with the locking opening 38 and which further has the opening 52', which helps define the belt receiving slot, 5 formed adjacent the opposite larger width rear end. A pair of stamped ribs 101a flanking the lateral sides of the opening 52' and a stamped rib 101b along the rear of the slot give the frame body 101 additional strength. The channel 53a is a cut out in the frame 50 and extends 10 forwardly from the main rectangular portion of the opening 52' toward the tongue 34. The detent 74 slides in the channel 53a and its forward end will abut a stopping surface 53b at the front end of the channel to hold the snubber slide 60 against sliding forwardly off 15 of the frame 50.

The liner 100 is molded as a unitary piece and includes a flat panel 102 that extends along the under side 105 of the frame body 101 and a lip 104 that extends upwardly along a rectangular insert opening 20 around the interior periphery of the frame body opening 52', defining the belt-receiving slot 52. The liner 100 has a thickened rear portion 106 with a channel 108 for receiving a rear bar portion 56 of the frame body 101 behind the slot opening 52' and has a pair of hollow 25 cylindrical projections 113 in front of the lip 104 that extend through a pair of holes 114 in the body flanking the channel 53a. The lip 104 has a gap 104a in the region of the channel 53a leaving the channel open to the rest of the frame slot 52. The liner 100 is applied 30 to the frame body 101 by slightly deforming the liner and sliding it rearwardly along the under side 105 of the frame body 101 so that the channel 108 engages the bar portion 56 and then snapping the front of the liner upward inserting the projections 113 into the holes 35 114. The front surface of the rear portion 106 of the liner 100 provides one of the walls 58 along which the belt 15 slides.

The snubber slide 60 is adapted to be fitted over the frame 50 prior to the belt being inserted through the slot 52. The snubber slide 60, as best seen in FIGURES 4 and 5, is a closed, channel-shaped body having the longitudinally extending slot 63 defined by four side walls viz, a top wall 66 and a bottom wall 68 joined to a pair of short side walls 62 at corner sections. The top wall 66 and bottom wall 68 are generally flat, planar and parallel. The top wall 66, the side walls 62 and opposed elongated flanges 124 (FIG. 5) of the bottom wall that extend forward of the rest of the bottom wall, provide channel-shaped regions 122 at the lateral sides of the slide 60 for receiving the lateral edges of the frame body 101 in a sliding engagement. Laterally inwards from the channel-shaped regions 122, an interior portion 123 of the bottom wall 68 is spaced further from the front wall 66 in order to pass below the liner panel 102 when the slide 60 is applied to the frame 50.

In accordance with another aspect of the invention, guide means 140 are provided for keeping the belt webbing centered and from folding onto itself or gathering in one corner of the tip as the webbing passes through the tip assembly 28. That is, it is undesirable that the belt fold or double onto itself or catch in a corner of the tip assembly. It is preferred that the belt track and slide cleanly through the tip. To these ends, in the illustrated embodiment, the guide means 140 consists of a pair of parallel tracks extending upward from the bottom wall 68 of the slide 62. The tracks 140 are laterally spaced apart just slightly more than the width of the belt 15 with inner facing vertical side walls for engaging the belt edges, preventing lateral displacement of the belt edges into an adjacent corner. The guide means 140 are found to substantially eliminate miscentering and subsequent twisting of the belt in its passage through the assembly 28, which may be a

problem. The preferred tracks are integrally molded ribs on the inner facing side of the wall 68 of the slide 62.

As an optional means of facilitating the
5 sliding of the belt along the forward surface of the rear wall, the rear wall of the slide 60 has a downwardly extending bead 144 that increases the radius of the surface 144' against which the belt 15 slides. It can be seen in FIGURE 3 that when the belt is free to
10 slide through the tip assembly 28, its rearward side 81 contacts two large radii surfaces formed of friction relieving material, i.e., the upper rounded corner 58' of the wall 58 and the rounded surface 144' of the bead 144. The bead 144 also strengthens the slide 60
15 providing more secure locking of the belt by the tip assembly 28 when the belt is extended across the passenger's lap.

To lock the snubber slide 60 onto the frame 50, a detent 74 projects downward and inward from the wall
20 66 and is adapted to be snap fitted into the frame slot 52 when the snubber slide 60 is positioned in place over the frame 50. The detent 74 restricts the forward sliding movement of the snubber slide 60 on the frame 50 to prevent disassembly thereof. The preferred detent 74
25 is an integrally molded narrow protrusion that depends from the center of the upper wall 66 through the slot 52 and into the channel 53a when the snubber slide 60 is in its forward position. The detent 74 is elongated in the sliding direction and has a front surface 148 that
30 serves as a stop against forward-disengaging motion. The stop surface 148 extends through the frame perpendicular to the sliding direction substantially to the level of the lower surface of the frame body 101 and engages the front surface 53b of the channel 53a that is
35 likewise perpendicular to the sliding direction. To assure sufficient locking engagement, the stop surface 148 should extend into the channel 53a to at least about

one half of the distance to the under side 105 of the frame body 101 and preferably the full distance through, as illustrated. The stop surface 148 should be at least perpendicular but may angle forward from the upper wall 5 66, in which case the front channel surface 53b should have a complementary angle. A cross protrusion 149 depending from the rear edge of the upper wall 66 just behind the detent 74 engages the forward edge 150 of the frame slot 52, assisting the detent in stopping forward 10 sliding of the snubber slide 60.

In order to assemble the tip assembly 28, the frame 50 and the snubber slide 60 are first telescoped relative to one another and brought to the position where the detent 74 snaps into the channel 53a. A 15 beveled surface 152 at the rear of the detent 74 facilitates sliding of the slide 60 onto the frame body by camming over the front end of the tongue 34 (and then over the rear edge of the locking opening 38) deforming the upper wall 66 so that the slide can be slid rearward 20 to where the detent 74 snaps into position.

The bottom wall 68 of the snubber slide 60 is very short and almost bar-shaped between its transverse forward edge 72, which abuts the belt when the tip assembly is buckled, as seen in FIGURE 2, and a rear 25 transverse edge 71. The forward transverse edge 72 of the bottom wall 68 is located only slightly forward of the upper rear edge 70 of the top wall 66, as clearly shown in FIGS. 2, 3 and 4. The bottom wall 68 is free to slide underneath the rear portion of the frame liner 30 100 when the tip is buckled.

When the tip assembly 28 has been assembled with the belt 15 fed therethrough, the belt passes through the frame slot 52 and also through the slot 63 in the snubber slide 60. As best seen in FIG. 3, the 35 normal weight imbalance caused by the tongue 34 will cant the tip assembly 28 relative to the vertical belt run 18. The snubber slide 60 has moved forwardly along

the frame 50 from the belt-gripping position of FIG. 2, and this allows the tip assembly to slide freely with the edges 70 and 58' on the snubber slide 60 and frame liner 100, respectively, sliding along the forward and rearward sides 80 and 81 of the belt. The unbuckled tip assembly 28 is thereby free to slide downward along the belt run 18 until stopped by some means, such as the detent 74 abutting the front channel surface 53b.

In order to engage the tip assembly 28 operatively with the buckle 30, the occupant merely grasps the tip assembly 28 and moves the same in a lateral direction and slides the tip assembly along the belt until the tongue 34 is brought to latch with the buckle 30, feeding out during this effort sufficient belt webbing to define the lap-engaging span 42 and the shoulder-engaging span 44. The extending belt is being pulled through the turning loop 22 and initially into the shoulder-engaging span 44 while the tip assembly 28 slides freely along the belt during this buckling operation. When the tip assembly 28 is engaged with the buckle 30, the pull of the retractor 26 exerts an upward and rightward force on the tip assembly, as viewed in FIGURES 1 and 2 shifting snubber slide 60 in this same direction to the belt-gripping position. (as seen in FIG. 2). In this position, the belt shoulder portion 44 trained about the forward edge 72 of the snubber slide 60 draws the snubber slide upwardly along the frame 50 until the upper grip edge 70 of the snubber slide 60 and the facing grip edge 58' on the frame liner 100 tightly squeeze the interpositioned belt 15. In this position, the tightly pinched belt 15 precludes any further withdrawal of the belt webbing in the direction toward the lap-engaging portion 42 which would tend to enlarge the lap-engaging portion. On the other hand, tension from the shoulder-engaging portion 44 allows the lap-engaging portion to be made tighter; while looseness of the shoulder-engaging portion 44 is permitted and

does not slip toward the lap-engaging portion 42.

The thickness of the rear portion 106 of the liner 100 is such that it projects upwardly to the level of the top surface the upper wall 66 of the snubber slide 60, and hence, this rear portion and the belt 15 limit the rearward movement of the snubber slide 60 on the frame 50.

In a preferred form of the illustrated tip assembly 28, the frame body 101 is formed of a durable structural material, such as steel, and the snubber slide 60 and the antiwear liner 100 are formed of a durable plastic material. The use of plastic for the slide 60 eliminates metal-to-metal rattling between pieces of the tip assembly. The plastic also provides the resiliency for the wall 66 to allow the detent 74 to be pushed over the top wall 65 of the frame body 101 during the initial assembly of the snubber slide 60 onto the frame 50. However, once the detent 74 has been positioned in the frame opening 52, it interlocks the slide 60 and frame 50 into an assembly 28 that will not fall apart during further assembly operations to insert the tip assembly onto the belt 15. The stiffness of the walls 66 and 68 are such that the snubber slide 60 can not be removed from the frame 50 without the use of a tool to spring the detent 74 upwardly and from the slot 53a in the frame.

A further advantage of a tip assembly 28 which is capable of freely sliding down the vertical belt run 18 is the reduction of the mass which the belt retractor must move during retraction. This allows for the use of a lighter clock-type rewind spring.

The use of a lighter rewind spring results in two end user advantages. Less force is needed to protract the belt, and less pressure will be exerted against the passenger's body if the belt tension is not relieved.

While a preferred embodiment has been shown and

described, it will be understood that there is no intent to limit the invention by such disclosure but, rather, it is intended to cover all modifications and alternate constructions falling within the spirit and scope of the invention. For example, the liner 100 could be eliminated allowing the belt 15 to slide on an upwardly turned rear wall of the metal frame. Also, the belt guiding tracks could be formed elsewhere than on the snubber slide, such as on the frame body or the frame liner.

Various features of the invention are recited in the appended claims.

CLAIMS

1. In a safety belt apparatus, the combination comprising: a safety belt having a shoulder portion and a lap portion, a seat belt retractor connected to one end of the safety belt and pulling on the belt for
5 rewinding the belt and for pulling a portion of the belt into a generally vertical position when the belt is released for full retraction, a tip assembly slidably mounted on the belt and having a tongue plate for connection to a buckle, and snubber means on the tip
10 assembly shiftable by the tongue plate hanging downwardly and with the belt in the vertical position to allow free sliding of the tip assembly downwardly along the belt, said snubber means being shifted to a belt gripping position by the belt under tension from the
15 retractor when the tongue plate is connected to the buckle.

2. A safety belt apparatus in accordance with Claim 1 in which the tip assembly comprises a belt-receiving slot through which the belt passes in the
20 tongue plate and said snubber means comprises a slide having an opening through which the belt passes, said slide and said tongue plate having facing walls at the upper rear portions thereof to engage opposite sides of said belt and to grip said belt therebetween.

25 3. A safety belt apparatus in accordance with Claim 2 in which said slide has a further belt-engaging wall on the bottom side of said slide and across which said belt engages and turns to form the lap section.

4. An apparatus in accordance with Claim 2 or Claim 3 in
30 which said tip assembly consists of a frame and a slide.

5. An apparatus in accordance with any of Claims 2 to 4 including a plurality of longitudinally extending internal walls on said slide defining a slot to slide over said tongue plate during assembly of said slide

onto said tongue plate, and deflectable detent means deflected when the slide is being assembled and then returning when assembled to limit the removal of the slide from the tongue plate.

5 6. An apparatus according to Claim 5, said detent having a forwardly facing front stop surface extending at least about 1/2 of the distance through said slot.

10 7. An apparatus according to Claim 6, said stop surface and a complementary rearwardly facing surface at the front of said slot belt-receiving being perpendicular to the sliding direction or angled forward.

15 8. An apparatus according to any of Claims 5 to 7, said slide being made of deformable material, said detent means having a rear camming surface for camming over said tip body, deforming said slide during application of said slide to said tip body.

20 9. An apparatus according to any of the preceding claims having means for guiding said belt through said assembly preventing lateral shifting of the belt within the assembly.

10. An apparatus according to Claim 9, said guide means being parallel tracks on said snubber means.

25 11. A tip assembly for use on a seat belt comprising: a tip body having a tongue at one end for hanging downwardly and for connection to a buckle, means defining a belt receiving slot at an upper rear end of the tip body and having the belt extending through the slot and including a rear transverse wall for snubbing
30 engagement with the belt, a slidable snubber means mounted on the tip body adjacent the slot for sliding toward said tongue or toward the upper end of said tip body, a rear transverse snubbing wall on said snubber means for engaging one side of the belt for clamping the
35 same against said rear transverse wall on said tip body, said rear transverse wall engageable with the other side of the belt when said snubber means is pulled upwardly

and rearwardly on the tip body by the belt tension, said snubber means having an opening therein through which passes the belt from one side of the snubber body to the other, and belt-engaging means on the snubber body for
5 abutting said other side of the belt for shifting said snubbing wall away from the clamping position when manual pressure is applied to said snubber means to shift the latter toward the tongue.

12. A tip assembly in accordance with Claim 11
10 in which the weight of said tongue causes the tip of said tip body to hang down when the belt is vertical and the tip assembly is released from the buckle, said snubbing means sliding to a non-snubbing position.

13. A tip assembly in accordance with Claim 12
15 in which the rear transverse snubbing wall on said tip body abuts the one side of the belt at a first upper location on the belt when the belt is vertical and the belt-engaging means slidably engages the same side of the vertical belt at a location beneath the rear
20 transverse snubbing wall to allow the tip assembly to slide freely down.

14. A tip assembly in accordance with Claim 12 or Claim 13 wherein said tip body comprises a metal member providing said slot and a friction relieving member
25 secured to said metal member, said friction relieving member providing said belt engaging means.

15. For seat belt apparatus, or the like, having a belt webbing extensibly spanned between two fixed locations and a buckle spaced laterally from each,
30 and a tip assembly mounted on the spanned belt webbing and moveable in the buckling condition freely along the length thereof and laterally toward the buckle in extending the spanned belt webbing to allow the tip assembly to be secured to the buckle in a buckled
35 condition, whereby the belt webbing disposed endwardly of the tip assembly toward the fixed locations defines, respectively, opposite lap and shoulder-engaging

portions, comprising the combination of an improved tip assembly having a planar and elongated frame member provided with a tongue and through opening means disposed adjacent opposite ends thereof, said opening
5 means being defined by spaced, mutually facing transverse edges disposed respectively adjacent and remote from the tongue; and a snubber slide of generally annular configuration fitted snugly over said frame member in the vicinity of said opening means and being
10 moveable only back and forth axially along said frame member, said snubber slide further having through opening means defined by spaced, oppositely facing transverse edges disposed respectively adjacent and remote from said tongue and spaced also laterally apart
15 relative to said frame member, the belt webbing being fitted through said opening means of the frame member and said snubber slide so that said lap-engaging portion trains off the adjacent transverse edge of said snubber slide, the remote transverse edges of the snubber slide
20 and the frame member being aligned laterally operable thereby to pinch the belt webbing therebetween, whereby axial tension in the buckled condition of said lap-engaging portion in the direction away from the tongue pinches the belt webbing firmly between said
25 remote transverse edges of said frame member and said snubber slide to preclude enlargement of said lap-engaging portion.

16. An improved tip assembly combination according to Claim 16, further providing that said
30 snubber slide presents a detent projection adapted to fit within the frame member opening means to limit thereby the axial back and forth movement of said snubber slide on said frame member by bottoming relative to the adjacent and remote transverse edges thereof.

35 17. An improved tip assembly combination according to Claim 16, further providing that said snubber slide opening means is the same as the through

bore of the annular configuration of said snubber slide.

18. For seat belt apparatus or the like having a belt webbing fixed at one end, a buckle spaced laterally from the end, and a tip assembly mounted on
5 the belt webbing and movable in the buckling condition along the length thereof to allow the tip assembly to be secured to the buckle in a buckled condition and define thereby a lap-engaging span, comprising the combination of an improved tip assembly having a planar frame member
10 provided with a tongue and with a transverse edge axially facing but disposed remote from the tongue; and a snubber slide of generally annular configuration fitted snugly over said frame member and being moveable only back and forth axially along said frame member,
15 said snubber slide further having oppositely facing transverse edges disposed respectively adjacent and remote from said tongue and spaced also laterally apart relative to said frame member, the belt webbing being fitted between the remote transverse edges of the frame
20 member and said snubber slide and said lap-engaging portion being trained off the adjacent transverse edge of the snubber slide, the remote transverse edges of said snubber slide and of said frame member being aligned laterally operable thereby to pinch the belt
25 webbing therebetween, whereby axial tension in the buckled condition of said lap-engaging portion in the direction away from the tongue pinches the belt webbing firmly between said remote transverse edges to preclude enlargement of said lap-engaging portion.

30 19. In a safety belt apparatus, the combination comprising: a safety belt having a shoulder portion and a lap portion, a seat belt retractor connected to one end of said safety belt and pulling on said belt for rewinding said belt and for pulling a
35 portion of said belt into a generally vertical position when said belt is released for full retraction, a tip assembly slidably mounted on the belt comprising a tip

body and a snubber slide mounted on said tip body for
sliding movement, said tip body having a tongue plate
for connection to a buckle, and said snubber slide being
shiftable by said tongue plate hanging downwardly and
5 with said belt in the vertical position to allow free
sliding of said tip assembly downwardly along said belt,
said snubber slide being shifted to a belt-gripping
position by said belt under tension from the retractor
when said tongue plate is connected to the buckle to
10 grip said belt and to prevent slack belt in said
shoulder portion from shifting into said lap portion.

11

