



(11) **EP 1 985 120 B1**

(12) **EUROPEAN PATENT SPECIFICATION**

(45) Date of publication and mention of the grant of the patent:
04.09.2019 Bulletin 2019/36

(51) Int Cl.:
H04N 7/24 (2011.01) G06T 9/00 (2006.01)
G06T 3/40 (2006.01)

(21) Application number: **07717801.0**

(86) International application number:
PCT/US2007/000195

(22) Date of filing: **08.01.2007**

(87) International publication number:
WO 2007/081752 (19.07.2007 Gazette 2007/29)

(54) **RESAMPLING AND PICTURE RESIZING OPERATIONS FOR MULTI-RESOLUTION VIDEO CODING AND DECODING**

NEUABTASTUNGS- UND BILDUMBEMESSUNGSOPERATIONEN ZUR VIDEOCODIERUNG UND DECODIERUNG MIT MEHRFACH-AUFLÖSUNG

OPERATIONS DE REECHANTILLONNAGE ET DE REDIMENSIONNEMENT D'IMAGES DESTINEES A UN CODAGE ET DECODAGE VIDEO A RESOLUTIONS MULTIPLES

(84) Designated Contracting States:
AT BE BG CH CY CZ DE DK EE ES FI FR GB GR HU IE IS IT LI LT LU LV MC NL PL PT RO SE SI SK TR

(30) Priority: **06.01.2006 US 756846 P**
27.03.2006 US 786573 P
13.10.2006 US 829515 P

(43) Date of publication of application:
29.10.2008 Bulletin 2008/44

(73) Proprietor: **Microsoft Technology Licensing, LLC**
Redmond, WA 98052 (US)

(72) Inventor: **SULLIVAN, Gary, J.**
Redmond, WA 98052-6399 (US)

(74) Representative: **Grünecker Patent- und Rechtsanwälte**
PartG mbB
Leopoldstraße 4
80802 München (DE)

(56) References cited:
WO-A1-2006/006777 WO-A1-2006/112620
US-A1- 2003 185 306 US-A1- 2006 093 036
US-B1- 6 728 317

EP 1 985 120 B1

Note: Within nine months of the publication of the mention of the grant of the European patent in the European Patent Bulletin, any person may give notice to the European Patent Office of opposition to that patent, in accordance with the Implementing Regulations. Notice of opposition shall not be deemed to have been filed until the opposition fee has been paid. (Art. 99(1) European Patent Convention).

Description

TECHNICAL FIELD

5 [0001] Techniques and tools for encoding/decoding digital video are described.

BACKGROUND

10 [0002] With the increased popularity of DVDs, music delivery over the Internet, and digital cameras, digital media have become commonplace. Engineers use a variety of techniques to process digital audio, video, and images efficiently while still maintaining quality. To understand these techniques, it helps to understand how the audio, video, and image information is represented and processed in a computer.

I. Representation of Media Information in a Computer

15 [0003] A computer processes media information as a series of numbers representing that information. For example, a single number may represent the intensity of brightness or the intensity of a color component such as red, green or blue for each elementary small region of a picture, so that the digital representation of the picture consists of one or more arrays of such numbers. Each such number may be referred to as a *sample*. For a color image, it is conventional to use more than one sample to represent the color of each elemental region, and typically three samples are used. The set of these samples for an elemental region may be referred to as a pixel, where the word "pixel" is a contraction referring to the concept of a "picture element." For example, one pixel may consist of three samples that represent the intensity of red, green and blue light necessary to represent the elemental region. Such a pixel type is referred to as an RGB pixel. Several factors affect quality of media information, including sample depth, resolution, and frame rate (for video).

20 [0004] Sample depth is a property normally measured in bits that indicates the range of numbers that can be used to represent a sample. When more values are possible for the sample, quality can be higher because the number can capture more subtle variations in intensity and/or a greater range of values. Resolution generally refers to the number of samples over some duration of time (for audio) or space (for images or individual video pictures). Images with higher spatial resolution tend to look crisper than other images and contain more discernable useful details. Frame rate is a common term for temporal resolution for video. Video with higher frame rate tends to mimic the smooth motion of natural objects better than other video, and can similarly be considered to contain more detail in the temporal dimension. For all of these factors, the tradeoff for high quality is the cost of storing and transmitting the information in terms of the bit rate necessary to represent the sample depth, resolution and frame rate, as Table 1 shows.

35 **Table 1: Bit rates for different quality levels of raw video**

Bits Per Pixel (sample depth times samples per pixel)	Resolution (in pixels, Width x Height)	Frame Rate (in frames per second)	Bit Rate (in millions of bits per second)
8 (value 0-255, monochrome)	160x120	7.5	1.2
24 (value 0-255, RGB)	320x240	15	27.6
24 (value 0-255, RGB)	640x480	30	221.2
24 (value 0-255, RGB)	1280x720	60	1327.1

40 [0005] Despite the high bit rate necessary for storing and sending high quality video (such as HDTV), companies and consumers increasingly depend on computers to create, distribute, and play back high quality content. For this reason, engineers use compression (also called source coding or source encoding) to reduce the bit rate of digital media. Compression decreases the cost of storing and transmitting the information by converting the information into a lower bit rate form. Compression can be lossless, in which quality of the video does not suffer but decreases in bit rate are limited by the complexity of the video. Or, compression can be lossy, in which quality of the video suffers but decreases in bit rate are more dramatic. Decompression (also called decoding) reconstructs a version of the original information from the compressed form. A "codec" is an encoder/decoder system.

55 [0006] In general, video compression techniques include "intra" compression and "inter" or predictive compression. For video pictures, intra compression techniques compress individual pictures. Inter compression techniques compress pictures with reference to preceding and/or following pictures. For instance, US 6728317 B1 discloses an image com-

pression method using temporal and resolution scalability by applying filtering techniques.

II. Multi-resolution Video and Spatial Scalability

5 **[0007]** Standard video encoders experience a dramatic degradation in performance when the target bit rate falls below a certain threshold. Quantization and other lossy processing stages introduce distortion. At low bitrates, high frequency information may be heavily distorted or completely lost. As a result, significant artifacts can arise and cause a substantial drop in the quality of the reconstructed video. Although available bit rates increase as transmission and processing technology improves, maintaining high visual quality at constrained bit rates remains a primary goal of video codec design. Existing codecs use several methods to improve visual quality at constrained bitrates.

10 **[0008]** Multi-resolution coding allows encoding of video at different spatial resolutions. Reduced resolution video can be encoded at a substantially lower bit rate, at the expense of lost information. For example, a prior video encoder can downsample (using a downsampling filter) full-resolution video and encode it at a reduced resolution in the vertical and/or horizontal directions. Reducing the resolution in each direction by half reduces the dimensions of the encoded picture size by half. The encoder signals the reduced resolution coding to a decoder. The decoder receives information indicating reduced-resolution encoding and ascertains from the received information how the reduced-resolution video should be upsampled (using an upsampling filter) to increase the picture size before display. However, the information that was lost when the encoder downsampled and encoded the video pictures is still missing from the upsampled pictures.

15 **[0009]** Spatially scalable video uses a multi-layer approach, allowing an encoder to reduce spatial resolution (and thus bit rate) in a base layer while retaining higher resolution information from the source video in one or more enhancement layers. For example, a base layer intra picture can be coded at a reduced resolution, while an accompanying enhancement layer intra picture can be coded at a higher resolution. Similarly, base layer predicted pictures can be accompanied by enhancement layer predicted pictures. A decoder can choose (based on bit rate constraints and/or other criteria) to decode only base layer pictures at the lower resolution to obtain lower resolution reconstructed pictures, or to decode base layer and enhancement layer pictures to obtain higher resolution reconstructed pictures. When the base layer is encoded at a lower resolution than the displayed picture (also referred to as downsampling), the encoded picture size is actually smaller than the displayed picture. The decoder performs calculations to resize the reconstructed picture and uses upsampling filters to produce interpolated sample values at appropriate positions in the reconstructed picture. However, previous codecs that use spatially scalable video have suffered from inflexible upsampling filters and inaccurate or expensive (in terms of computation time or bit rate) picture resizing techniques.

20 **[0010]** Given the critical importance of video compression and decompression to digital video, it is not surprising that video compression and decompression are richly developed fields. Whatever the benefits of previous video compression and decompression techniques, however, they do not have the advantages of the following techniques and tools.

35 SUMMARY

[0011] This Summary is provided to introduce a selection of concepts in a simplified form that are further described below in the Detailed Description. This Summary is not intended to identify key features or essential features of the claimed subject matter, nor is it intended to be used to limit the scope of the claimed subject matter.

40 **[0012]** In summary, the Detailed Description is directed to various techniques and tools for multi-resolution and layered spatially scalable video coding and decoding.

[0013] For example, the Detailed Description is directed to various techniques and tools for high accuracy position calculation for picture resizing in applications such as spatially-scalable video coding and decoding. Techniques and tools for high accuracy position calculation for picture resizing in applications such as spatially-scalable video coding and decoding are described. In one aspect, resampling of a video picture is performed according to a resampling scale factor. The resampling comprises computation of a sample value at a position i,j in a resampled array. The computation includes computing a derived horizontal or vertical sub-sample position x or y in a manner that involves approximating a value in part by multiplying a 2^n value by an inverse (approximate or exact) of the upsampling scale factor (or dividing the 2^n value by the upsampling scale factor or an approximation of the upsampling scale factor). The exponent n may be a sum of two integers including an integer F that represents a number of bits in a fractional component. The approximating can be a rounding or some other kind of approximating, such as a ceiling or floor function that approximates to a nearby integer. The sample value is interpolated using a filter.

50 **[0014]** Some alternatives of the described techniques provide an altered sample position computation that in one implementation provides approximately one extra bit of precision in the computations without significantly altering the sample position computation process or its complexity. Some further alternatives of the described techniques relate to how the sample position computation operates with 4:2:2 and 4:4:4 sampling structures. These alternative techniques for such sampling structures lock the luma and chroma sample position calculations together whenever the resolution of the chroma and luma sampling grid is the same in a particular dimension.

[0015] Additional features and advantages will be made apparent from the following detailed description of various embodiments that proceeds with reference to the accompanying drawings.

BRIEF DESCRIPTION OF THE DRAWINGS

5

[0016]

Figure 1 is a block diagram of a suitable computing environment in conjunction with which several described embodiments may be implemented.

10 Figure 2 is a block diagram of a generalized video encoder system in conjunction with which several described embodiments may be implemented.

Figure 3 is a block diagram of a generalized video decoder system in conjunction with which several described embodiments may be implemented.

Figure 4 is a diagram of a macroblock format used in several described embodiments.

15 Figure 5A is a diagram of part of an interlaced video frame, showing alternating lines of a top field and a bottom field. Figure 5B is a diagram of the interlaced video frame organized for encoding/decoding as a frame, and Figure 5C is a diagram of the interlaced video frame organized for encoding/decoding as fields.

Figure 5D shows six example spatial alignments of 4:2:0 chroma sample locations relative to luma sample locations for each field of a video frame.

20 Figure 6 is a flowchart showing a generalized technique for multi-resolution encoding of video.

Figure 7 is a flowchart showing a generalized technique for multi-resolution decoding of video.

Figure 8 is a flowchart showing a technique for multi-resolution encoding of intra pictures and inter-picture predicted pictures.

25 Figure 9 is a flowchart showing a technique for multi-resolution decoding of intra pictures and inter-picture predicted pictures.

Figure 10 is a flowchart showing a technique for encoding spatially scalable bitstream layers to allow decoding video at different resolutions.

Figure 11 is a flowchart showing a technique for decoding spatially scalable bitstream layers to allow decoding video at different resolutions.

30 Figures 12 and 13 are code diagrams showing pseudo-code for an example multi-stage position calculation technique.

Figure 14 is a code diagram showing pseudo-code for an example incremental position calculation technique.

DETAILED DESCRIPTION

35

[0017] Described embodiments are directed to techniques and tools for multi-resolution and layered spatially scalable video coding and decoding.

[0018] The various techniques and tools described herein may be used independently. Some of the techniques and tools may be used in combination (e.g., in different phases of a combined encoding and/or decoding process).

40 [0019] Various techniques are described below with reference to flowcharts of processing acts. The various processing acts shown in the flowcharts may be consolidated into fewer acts or separated into more acts. For the sake of simplicity, the relation of acts shown in a particular flowchart to acts described elsewhere is often not shown. In many cases, the acts in a flowchart can be reordered.

45 [0020] Much of the detailed description addresses representing, coding, and decoding video information. Techniques and tools described herein for representing, coding, and decoding video information may be applied to audio information, still image information, or other media information.

I. Computing Environment

50 [0021] Figure 1 illustrates a generalized example of a suitable computing environment 100 in which several of the described embodiments may be implemented. The computing environment 100 is not intended to suggest any limitation as to scope of use or functionality, as the techniques and tools may be implemented in diverse general-purpose or special-purpose computing environments.

55 [0022] With reference to Figure 1, the computing environment 100 includes at least one processing unit 110 and memory 120. In Figure 1, this most basic configuration 130 is included within a dashed line. The processing unit 110 executes computer-executable instructions and may be a real or a virtual processor. In a multi-processing system, multiple processing units execute computer-executable instructions to increase processing power. The memory 120 may be volatile memory (e.g., registers, cache, RAM), nonvolatile memory (e.g., ROM, EEPROM, flash memory, etc.),

or some combination of the two. The memory 120 stores software 180 implementing a video encoder or decoder with one or more of the described techniques and tools.

[0023] A computing environment may have additional features. For example, the computing environment 100 includes storage 140, one or more input devices 150, one or more output devices 160, and one or more communication connections 170. An interconnection mechanism (not shown) such as a bus, controller, or network interconnects the components of the computing environment 100. Typically, operating system software (not shown) provides an operating environment for other software executing in the computing environment 100, and coordinates activities of the components of the computing environment 100.

[0024] The storage 140 may be removable or non-removable, and includes magnetic disks, magnetic tapes or cassettes, CD-ROMs, DVDs, flash memory, or any other medium which can be used to store information and which can be accessed within the computing environment 100. The storage 140 stores instructions for the software 180 implementing the video encoder or decoder.

[0025] The input device(s) 150 may be a touch input device such as a keyboard, mouse, pen, touch screen, or trackball, a voice input device, a scanning device, or another device that provides input to the computing environment 100. For audio or video encoding, the input device(s) 150 may be a sound card, video card, TV tuner card, or similar device that accepts audio or video input in analog or digital form, or a CD-ROM, CD-RW or DVD that reads audio or video samples into the computing environment 100. The output device(s) 160 may be a display, printer, speaker, CD- or DVD-writer, or another device that provides output from the computing environment 100.

[0026] The communication connection(s) 170 enable communication over a communication medium to another computing entity. The communication medium conveys information such as computer-executable instructions, audio or video input or output, or other data in a modulated data signal. A modulated data signal is a signal that has one or more of its characteristics set or changed in such a manner as to encode information in the signal. By way of example, and not limitation, communication media include wired or wireless techniques implemented with an electrical, optical, RF, infrared, acoustic, or other carrier.

[0027] The techniques and tools can be described in the general context of computer-readable media. Computer-readable media are any available media that can be accessed within a computing environment. By way of example, and not limitation, with the computing environment 100, computer-readable media include memory 120, storage 140, communication media, and combinations of any of the above.

[0028] The techniques and tools can be described in the general context of computer-executable instructions, such as those included in program modules, being executed in a computing environment on one or more target real processors or virtual processors. Generally, program modules include routines, programs, libraries, objects, classes, components, data structures, etc. that perform particular tasks or implement particular abstract data types. The functionality of the program modules may be combined or split between program modules as desired in various embodiments. Computer-executable instructions for program modules may be executed within a local or distributed computing environment.

[0029] For the sake of presentation, the detailed description uses terms like "encode," "decode," and "choose" to describe computer operations in a computing environment. These terms are high-level abstractions for operations performed by a computer, and should not be confused with acts performed by a human being. The actual computer operations corresponding to these terms vary depending on implementation.

II. Example Video Encoder and Decoder

[0030] Figure 2 is a block diagram of an example video encoder 200 in conjunction with which some described embodiments may be implemented. Figure 3 is a block diagram of a generalized video decoder 300 in conjunction with which some described embodiments may be implemented.

[0031] The relationships shown between modules within the encoder 200 and decoder 300 indicate general flows of information in the encoder and decoder; other relationships are not shown for the sake of simplicity. In particular, Figures 2 and 3 usually do not show side information indicating the encoder settings, modes, tables, etc. used for a video sequence, picture, slice, macroblock, block, etc. Such side information is sent in the output bitstream, typically after entropy encoding of the side information. The format of the output bitstream may vary depending on implementation.

[0032] The encoder 200 and decoder 300 process video pictures, which may be video frames, video fields or combinations of frames and fields. The bitstream syntax and semantics at the picture and macroblock levels may depend on whether frames or fields are used. There may be changes to macroblock organization and overall timing as well. The encoder 200 and decoder 300 are block-based and use a 4:2:0 macroblock format for frames, with each macroblock including four 8x8 luminance blocks (at times treated as one 16x16 macroblock) and two 8x8 chrominance blocks. For fields, the same or a different macroblock organization and format may be used. The 8x8 blocks may be further subdivided at different stages, e.g., at the frequency transform and entropy encoding stages. Example video frame organizations are described in more detail below. Alternatively, the encoder 200 and decoder 300 are object-based, use a different macroblock or block format, or perform operations on sets of samples of different size or configuration than 8x8

blocks and 16x16 macroblocks.

[0033] Depending on implementation and the type of compression desired, modules of the encoder or decoder can be added, omitted, split into multiple modules, combined with other modules, and/or replaced with like modules. In alternative embodiments, encoders or decoders with different modules and/or other configurations of modules perform one or more of the described techniques.

A. Video Frame Organizations

[0034] In some implementations, the encoder 200 and decoder 300 process video frames organized as follows. A frame contains lines of spatial information of a video signal. For progressive video scanning, these lines contain samples representing a snapshot of scene content sampled at the same time instant and covering the entire scene from the top to the bottom of the frame. A progressive video frame is divided into macroblocks, such as the macroblock 400 shown in Figure 4. The macroblock 400 includes four 8x8 luminance blocks (Y1 through Y4) and two 8x8 chrominance blocks that are co-located with the four luminance blocks but half resolution horizontally and vertically, following the conventional 4:2:0 macroblock format. The 8x8 blocks may be further sub-divided at different stages, e.g., at the frequency transform (e.g., 8x4, 4x8 or 4x4 DCTs) and entropy encoding stages. A progressive I-frame is an intra-coded progressive video frame, where the term "intra" refers to coding methods that do not involve prediction from the content of other previously-decoded pictures. A progressive P-frame is a progressive video frame coded using prediction from one or more other pictures at time instances that temporally differ from that of the current picture (sometimes referred to as forward prediction in some contexts), and a progressive B-frame is a progressive video frame coded using inter-frame prediction involving a (possibly weighted) averaging of multiple prediction values in some regions (sometimes referred to as bi-predictive or bi-directional prediction). Progressive P- and B-frames may include intra-coded macroblocks as well as various types of inter-frame predicted macroblocks.

[0035] Interlaced video frame scanning consists of an alternating series of two types of scans of a scene - one, referred to as the top field, comprising the even lines (lines numbered 0, 2, 4, etc.) of a frame, and the other, referred to as the bottom field, comprising the odd lines (lines numbered 1, 3, 5, etc.) of the frame. The two fields typically represent two different snapshot time instants. Figure 5A shows part of an interlaced video frame 500, including the alternating lines of the top field and bottom field at the top left part of the interlaced video frame 500.

[0036] Figure 5B shows the interlaced video frame 500 of Figure 5A organized for encoding/decoding as a frame 530. The interlaced video frame 500 has been partitioned into macroblocks or other such regions such as the macroblocks 531 and 532, which use a 4:2:0 format as shown in Figure 4. In the luminance plane, each macroblock 531, 532 includes 8 lines from the top field alternating with 8 lines from the bottom field for 16 lines total, and each line is 16 samples long. (The actual organization of the picture into macroblocks or other such regions and the placement of luminance blocks and chrominance blocks within the macroblocks 531, 532 are not shown, and in fact may vary for different encoding decisions and for different video coding designs.) Within a given macroblock, the top-field information and bottom-field information may be coded jointly or separately at any of various phases.

[0037] An interlaced I-frame is an intra-coded interlaced video frame containing two fields, where each macroblock includes information for one or both fields. An interlaced P-frame is an interlaced video frame containing two fields that is coded using inter-frame prediction, where each macroblock includes information for one or both fields, as is an interlaced B-frame. Interlaced P- and B-frames may include intra-coded macroblocks as well as various types of inter-frame predicted macroblocks.

[0038] Figure 5C shows the interlaced video frame 500 of Figure 5A organized for encoding/decoding as fields 560. Each of the two fields of the interlaced video frame 500 is partitioned into macroblocks. The top field is partitioned into macroblocks such as the macroblock 561, and the bottom field is partitioned into macroblocks such as the macroblock 562. (Again, the macroblocks use a 4:2:0 format as shown in Figure 4, and the organization of the picture into macroblocks or other such regions and placement of luminance blocks and chrominance blocks within the macroblocks are not shown and may vary.) In the luminance plane, the macroblock 561 includes 16 lines from the top field and the macroblock 562 includes 16 lines from the bottom field, and each line is 16 samples long.

[0039] An interlaced I-field is a single, separately represented field of an interlaced video frame. An interlaced P-field is a single, separately represented field of an interlaced video frame coded using inter-picture prediction, as is an interlaced B-field. Interlaced P- and B-fields may include intra-coded macroblocks as well as different types of inter-picture predicted macroblocks.

[0040] Interlaced video frames organized for encoding/decoding as fields may include various combinations of different field types. For example, such a frame may have the same field type (I-field, P-field, or B-field) in both the top and bottom fields or different field types in each field.

[0041] The term picture generally refers to a frame or field of source, coded or reconstructed image data. For progressive-scan video, a picture is typically a progressive video frame. For interlaced video, a picture may refer to an interlaced video frame, the top field of a frame, or the bottom field of a frame, depending on the context.

[0042] Figure 5D shows six example spatial alignments of 4:2:0 chroma sample locations relative to luma sample locations for each field of a video frame.

[0043] Alternatively, the encoder 200 and decoder 300 are object-based, use a different macroblock format (e.g., 4:2:2 or 4:4:4) or block format, or perform operations on sets of samples of different size or configuration than 8x8 blocks and 16x16 macroblocks.

B. Video Encoder

[0044] Figure 2 is a block diagram of an example video encoder system 200. The encoder system 200 receives a sequence of video pictures including a current picture 205 (e.g., progressive video frame, interlaced video frame, or field of an interlaced video frame), and produces compressed video information 295 as output. Particular embodiments of video encoders typically use a variation or supplemented version of the example encoder 200.

[0045] The encoder system 200 uses encoding processes for intra-coded (intra) pictures (I-pictures) and inter-picture predicted (inter) pictures (P- or B-pictures). For the sake of presentation, Figure 2 shows a path for I-pictures through the encoder system 200 and a path for inter-picture predicted pictures. Many of the components of the encoder system 200 are used for compressing both I-pictures and inter-picture predicted pictures. The exact operations performed by those components may vary depending on the type of information being compressed.

[0046] An inter-picture predicted picture is represented in terms of a prediction (or difference) from one or more other pictures (which are typically referred to as reference pictures). A prediction residual is the difference between what was predicted and the original picture. In contrast, an I-picture is compressed without reference to other pictures. I-pictures may use spatial prediction or frequency-domain prediction (i.e., intra-picture prediction) to predict some portions of the I-picture using data from other portions of the I-picture itself. However, for the sake of brevity, such I-pictures are not referred to in this description as "predicted" pictures, so that the phrase "predicted picture" can be understood to be an inter-picture predicted picture (e.g., a P- or B-picture).

[0047] If the current picture 205 is a predicted picture, a motion estimator 210 estimates motion of macroblocks or other sets of samples of the current picture 205 with respect to one or more reference pictures, for example, the reconstructed previous picture 225 buffered in the picture store 220. A motion estimator 210 may estimate motion with respect to one or more temporally previous reference pictures and one or more temporally future reference pictures (e.g., in the case of a bi-predictive picture). Accordingly, the encoder system 200 may use the separate stores 220 and 222 for multiple reference pictures.

[0048] The motion estimator 210 may estimate motion by full-sample, $\frac{1}{2}$ -sample, $\frac{1}{4}$ -sample, or other increments, and may switch the resolution of the motion estimation on a picture-by-picture basis or other basis. The motion estimator 210 (and compensator 230) also may switch between types of reference picture sample interpolation (e.g., between cubic convolution interpolation and bilinear interpolation) on a per-frame or other basis. The resolution of the motion estimation may be the same or different horizontally and vertically. The motion estimator 210 outputs, as side information, motion information 215 such as differential motion vector information. The encoder 200 encodes the motion information 215 by, for example, computing one or more predictors for motion vectors, computing differences between the motion vectors and predictors, and entropy coding the differences. To reconstruct a motion vector, a motion compensator 230 combines a predictor with motion vector difference information.

[0049] The motion compensator 230 applies the reconstructed motion vector to the reconstructed picture(s) 225 to form a motion-compensated prediction 235. The prediction is rarely perfect, however, and the difference between the motion-compensated prediction 235 and the original current picture 205 is the prediction residual 245. During later reconstruction of the picture, an approximation of the prediction residual 245 will be added to the motion compensated prediction 235 to obtain a reconstructed picture that is closer to the original current picture 205 than the motion-compensated prediction 235. In lossy compression, however, some information is still lost from the original current picture 205. Alternatively, a motion estimator and motion compensator apply another type of motion estimation/compensation.

[0050] A frequency transformer 260 converts the spatial domain video information into frequency domain (i.e., spectral) data. For block-based video coding, the frequency transformer 260 typically applies a discrete cosine transform (DCT), a variant of a DCT, or some other block transform to blocks of the sample data or prediction residual data, producing blocks of frequency-domain transform coefficients. Alternatively, the frequency transformer 260 applies another type of frequency transform such as a Fourier transform or uses wavelet or sub-band analysis. The frequency transformer 260 may apply an 8x8, 8x4, 4x8, 4x4 or other size frequency transform.

[0051] A quantizer 270 then quantizes the blocks of frequency-domain transform coefficients. The quantizer applies scalar quantization to the transform coefficients according to a quantization step-size that varies on a picture-by-picture basis, a macroblock basis, or some other basis, where the quantization step size is a control parameter that governs the uniformly-spaced spacing between discrete representable reconstruction points in the decoder inverse quantizer process, which may be duplicated in an encoder inverse quantizer process 276. Alternatively, the quantizer applies another type of quantization to the frequency-domain transform coefficients, for example, a scalar quantizer with non-

uniform reconstruction points, a vector quantizer, or non-adaptive quantization, or directly quantizes spatial domain data in an encoder system that does not use frequency transformations. In addition to adaptive quantization, the encoder 200 may use frame dropping, adaptive filtering, or other techniques for rate control.

5 **[0052]** When a reconstructed current picture is needed for subsequent motion estimation/compensation, an inverse quantizer 276 performs inverse quantization on the quantized frequency-domain transform coefficients. An inverse frequency transformer 266 then performs the inverse of the operations of the frequency transformer 260, producing a reconstructed prediction residual approximation (for a predicted picture) or a reconstructed I-picture approximation. If the current picture 205 was an I-picture, the reconstructed I-picture approximation is taken as the reconstructed current picture approximation (not shown). If the current picture 205 was a predicted picture, the reconstructed prediction residual approximation is added to the motion-compensated prediction 235 to form the reconstructed current picture approximation. One or more of the picture stores 220, 222 buffers the reconstructed current picture approximation for use as a reference picture in motion compensated prediction of subsequent pictures. The encoder may apply a de-blocking filter or other picture refining process to the reconstructed frame to adaptively smooth discontinuities and remove other artifacts from the picture prior to storing the picture approximation into one or more picture stores 220, 222.

15 **[0053]** The entropy coder 280 compresses the output of the quantizer 270 as well as certain side information (e.g., motion information 215, quantization step size). Typical entropy coding techniques include arithmetic coding, differential coding, Huffman coding, run length coding, Lempel-Ziv coding, dictionary coding, and combinations of the above. The entropy coder 280 typically uses different coding techniques for different kinds of information (e.g., low-frequency coefficients, high-frequency coefficients, zero-frequency coefficients, different kinds of side information), and may choose from among multiple code tables within a particular coding technique.

20 **[0054]** The entropy coder 280 provides compressed video information 295 to the multiplexer ["MUX"] 290. The MUX 290 may include a buffer, and a buffer fullness level indicator may be fed back to bit rate adaptive modules for rate control. Before or after the MUX 290, the compressed video information 295 may be channel coded for transmission over the network. The channel coding may apply error detection and correction data to the compressed video information 295.

C. Video Decoder

30 **[0055]** Figure 3 is a block diagram of an example video decoder system 300. The decoder system 300 receives information 395 for a compressed sequence of video pictures and produces output including a reconstructed picture 305 (e.g., progressive video frame, interlaced video frame, or field of an interlaced video frame). Particular embodiments of video decoders typically use a variation or supplemented version of the generalized decoder 300.

35 **[0056]** The decoder system 300 decompresses predicted pictures and I-pictures. For the sake of presentation, Figure 3 shows a path for I-pictures through the decoder system 300 and a path for predicted pictures. Many of the components of the decoder system 300 are used for decompressing both I-pictures and predicted pictures. The exact operations performed by those components may vary depending on the type of information being decompressed.

40 **[0057]** A DEMUX 390 receives the information 395 for the compressed video sequence and makes the received information available to the entropy decoder 380. The DEMUX 390 may include a jitter buffer and other buffers as well. Before or within the DEMUX 390, the compressed video information may be channel decoded and processed for error detection and correction.

45 **[0058]** The entropy decoder 380 entropy decodes entropy-coded quantized data as well as entropy-coded side information (e.g., motion information 315, quantization step size), typically applying the inverse of the entropy encoding performed in the encoder. Entropy decoding techniques include arithmetic decoding, differential decoding, Huffman decoding, run length decoding, Lempel-Ziv decoding, dictionary decoding, and combinations of the above. The entropy decoder 380 typically uses different decoding techniques for different kinds of information (e.g., low-frequency coefficients, high-frequency coefficients, zero-frequency coefficients, different kinds of side information), and may choose from among multiple code tables within a particular decoding technique.

50 **[0059]** The decoder 300 decodes the motion information 315 by, for example, computing one or more predictors for motion vectors, entropy decoding motion vector differences (at entropy decoder 380), and combining decoded motion vector differences with predictors to reconstruct motion vectors.

55 **[0060]** A motion compensator 330 applies motion information 315 to one or more reference pictures 325 to form a prediction 335 of the picture 305 being reconstructed. For example, the motion compensator 330 uses one or more macroblock motion vectors to find blocks of samples or to interpolate fractional positions between samples in the reference picture(s) 325. One or more picture stores (e.g., picture store 320, 322) store previous reconstructed pictures for use as reference pictures. Typically, B-pictures have more than one reference picture (e.g., at least one temporally previous reference picture and at least one temporally future reference picture). Accordingly, the decoder system 300 may use separate picture stores 320 and 322 for multiple reference pictures. The motion compensator 330 may compensate for motion at full-sample, $\frac{1}{2}$ sample, $\frac{1}{4}$ sample, or other increments, and may switch the resolution of the motion compensation

on a picture-by-picture basis or other basis. The motion compensator 330 also may switch between types of reference picture sample interpolation (e.g., between cubic convolution interpolation and bilinear interpolation) on a per-frame or other basis. The resolution of the motion compensation may be the same or different horizontally and vertically. Alternatively, a motion compensator applies another type of motion compensation. The prediction by the motion compensator is rarely perfect, so the decoder 300 also reconstructs prediction residuals.

[0061] An inverse quantizer 370 inverse quantizes entropy-decoded data. Typically, the inverse quantizer applies uniform scalar inverse quantization to the entropy-decoded data with a reconstruction step-size that varies on a picture-by-picture basis, a macroblock basis, or some other basis. Alternatively, the inverse quantizer applies another type of inverse quantization to the data, for example, a non-uniform, vector, or non-adaptive inverse quantization, or directly

inverse quantizes spatial domain data in a decoder system that does not use inverse frequency transformations.

[0062] An inverse frequency transformer 360 converts the inverse quantized frequency domain transform coefficients into spatial domain video information. For block-based video pictures, the inverse frequency transformer 360 applies an inverse DCT ["IDCT"], a variant of IDCT, or some other inverse block transform to blocks of the frequency transform coefficients, producing sample data or inter-picture prediction residual data for I-pictures or predicted pictures, respectively. Alternatively, the inverse frequency transformer 360 applies another type of inverse frequency transform such as an inverse Fourier transform or uses wavelet or sub-band synthesis. The inverse frequency transformer 360 may apply an 8x8, 8x4, 4x8, 4x4, or other size inverse frequency transform.

[0063] For a predicted picture, the decoder 300 combines the reconstructed prediction residual 345 with the motion compensated prediction 335 to form the reconstructed picture 305. When the decoder needs a reconstructed picture 305 for subsequent motion compensation, one or more of the picture stores (e.g., picture store 320) buffers the reconstructed picture 305 for use in predicting the next picture. In some embodiments, the decoder 300 applies a de-blocking filter or other picture refining process to the reconstructed picture to adaptively smooth discontinuities and remove other artifacts from the picture prior to storing the reconstructed picture 305 into one or more of the picture stores (e.g., picture store 320) or prior to displaying the decoded picture during decoded video play-out.

III. General Overview of Multi-resolution Encoding and Decoding

[0064] Video can be encoded (and decoded) at different resolutions. For the purposes of this description, multi-resolution encoding and decoding can be described as frame-based coding and decoding (e.g., reference picture resampling) or layered (sometimes referred to as spatial scalable) coding and decoding. Multi-resolution encoding and decoding could also involve interlaced video and field-based encoding and decoding and switching between frame-based and field-based encoding and decoding on a resolution-specific basis or on some other basis. However, frame coding of progressive video is discussed in this overview for purposes of simplifying the concept description.

A. Frame-based Multi-resolution Encoding and Decoding

[0065] In frame-based multi-resolution coding, an encoder encodes input pictures at different resolutions. The encoder chooses the spatial resolution for pictures on a picture-by-picture basis or on some other basis. For example, in reference picture resampling, a reference picture can be resampled if it is encoded at a different resolution from that of the picture being encoded. The term resampling is used to describe increasing (upsampling) or decreasing (downsampling) the number of samples used to represent a picture area or some other section of a sampled signal. The number of samples per unit area or per signal section is referred to as the resolution of the sampling.

[0066] Spatial resolution can be chosen based on, for example, an decrease/increase in available bit rate, decrease/increase in quantization step size, decrease/increase in the amount of motion in the input video content, other properties of the video content (e.g., presence of strong edges, text, or other content that may be significantly distorted at lower resolutions), or some other basis. Spatial resolution can be varied in vertical, horizontal, or both vertical and horizontal dimensions. Horizontal resolution may be the same as or different than vertical resolution. A decoder decodes encoded frames using complementary techniques.

[0067] Once the encoder has chosen a spatial resolution for a current picture or area within a current picture, the encoder re-samples the original picture to the desired resolution before coding it. The encoder can then signal the choice of spatial resolution to the decoder.

[0068] Figure 6 shows a technique (600) for frame-based multi-resolution encoding of pictures. An encoder, such as encoder 200 in Figure 2 sets a resolution (610) for a picture. For example, the encoder considers the criteria listed above or other criteria. The encoder then encodes the picture (620) at that resolution. If the encoding of all pictures that are to be encoded is done (630), the encoder exits. If not, the encoder sets a resolution (610) for the next picture and continues encoding. Alternatively, the encoder sets resolutions at some level other than picture level, such as setting the resolution differently for different parts of picture or making a resolution selection for a group or sequence of pictures.

[0069] The encoder may encode predicted pictures as well as intra pictures. Figure 8 shows a technique (800) for

frame-based multi-resolution encoding of intra pictures and inter-picture predicted pictures. First, the encoder checks at 810 whether the current picture to be encoded is an intra picture or a predicted picture. If the current picture is an intra picture, the encoder sets the resolution for the current picture at 820. If the picture is a predicted picture, the encoder sets the resolution for the reference picture at 830 before setting the resolution for the current picture. After setting the resolution for the current picture, the encoder encodes the current picture (840) at that resolution. Setting the resolution for a picture (whether a current source picture or a stored reference picture) may involve resampling the picture to match the selected resolution and may involve encoding a signal to indicate the selected resolution to the decoder. If the encoding of all pictures that are to be encoded is done (850), the encoder exits. If not, the encoder continues encoding additional pictures. Alternatively, the encoder treats predicted pictures in a different way.

[0070] A decoder decodes the encoded picture, and, if necessary, resamples the picture before display. Like the resolution of the encoded picture, the resolution of the decoded picture can be adjusted in many different ways. For example, the resolution of the decoded picture can be adjusted to fit the resolution of an output display device or of a region of an output display device (for example, for "picture-in-picture" or PC desktop window display).

[0071] Figure 7 shows a technique (700) for frame-based multi-resolution decoding of pictures. A decoder, such as decoder 300 in Figure 3, sets a resolution (at 710) for a picture. For example, the decoder gets resolution information from the encoder. The decoder then decodes the picture (720) at that resolution. If the decoding of all pictures that are to be decoded is done (730), the decoder exits. If not, the decoder sets a resolution (710) for the next picture and continues decoding. Alternatively, the decoder sets resolutions at some level other than picture level.

[0072] The decoder may decode predicted pictures as well as intra pictures. Figure 9 shows a technique (900) for frame-based multi-resolution decoding of intra pictures and predicted pictures.

[0073] First, the decoder checks whether the current frame to be decoded is an intra picture or a predicted picture (910). If the current picture is an intra picture, the decoder sets the resolution for the current picture (920). If the picture is a predicted picture, the decoder sets the resolution for the reference picture (930) before setting the resolution for the current picture (920). Setting the resolution of the reference picture may involve resampling the stored reference picture to match the selected resolution. After setting the resolution for the current picture (920), the decoder decodes the current picture (940) at that resolution. If the decoding of all pictures that are to be decoded is done (950), the decoder exits. If not, the decoder continues decoding.

[0074] The decoder typically decodes pictures at the same resolutions used in the encoder. Alternatively, the decoder decodes pictures at different resolutions, such as when the resolutions available to the decoder are not exactly the same as those used in the encoder.

B. Layered Multi-resolution Encoding and Decoding

[0075] In layered multi-resolution coding, an encoder encodes video in layers, with each layer having information for decoding the video at a different resolution. In this way, the encoder encodes at least some individual pictures in the video at more than one resolution. A decoder can then decode the video at one or more resolutions by processing different combinations of layers. For example, a first layer (sometimes referred to as a base layer) contains information for decoding video at a lower resolution, while one or more other layers (sometimes referred to as enhancement layers) contain information for decoding the video at higher resolutions.

[0076] The base layer may be designed to itself be an independently decodable bitstream. Thus, in such a design, a decoder that decodes only the base layer will produce a valid decoded bitstream at the lower resolution of the base layer. Proper decoding of higher-resolution pictures using an enhancement layer may require also decoding some or all of the encoded base layer data and possibly of one or more enhancement layers. A decoder that decodes the base layer and one or more other higher-resolution layers will be able to produce higher resolution content than a decoder that decodes only the base layer. Two, three or more layers may be used to allow for two, three or more different resolutions. Alternatively, a higher resolution layer may itself also be an independently decodable bitstream. (Such a design is often referred to as a simulcast multi-resolution encoding approach.)

[0077] Figure 10 shows a technique (1000) for encoding bitstream layers to allow decoding at different resolutions. An encoder such as encoder 200 in Figure 2 takes full-resolution video information as input (1010). The encoder down-samples the full-resolution video information (1020) and encodes the base layer using the downsampled information (1030). The encoder encodes one or more higher-resolution layers using the base layer and higher-resolution video information (1040). A higher-resolution layer can be a layer that allows decoding at full resolution, or a layer that allows decoding at some intermediate resolution. The encoder then outputs a layered bitstream comprising two more of the encoded layers. Alternatively, the encoding of the higher-resolution layer (1040) may not use base layer information and may thus enable the independent decoding of the higher-resolution layer data for a simulcast multi-resolution encoding approach.

[0078] The encoder can accomplish multi-resolution layer encoding in several ways following the basic outline shown in Figure 10. For more information, see, e.g., U.S. Patent No. 6,510,177, or the MPEG-2 standard or other video standards.

[0079] Figure 11 shows a technique (1100) for decoding bitstream layers to allow decoding video at different resolutions. A decoder such as decoder 300 in Figure 3 takes a layered bitstream as input (1110). The layers include a lower-resolution layer (base layer) and one or more layers comprising higher-resolution information. The higher-resolution layers need not contain independently encoded pictures; typically, higher-resolution layers include residual information that describes differences between higher- and lower-resolution versions of pictures. The decoder decodes the base layer (1120) and, if higher-resolution decoding is desired, the decoder upsamples the decoded base layer pictures (1130) to the desired resolution. The decoder decodes one or more higher-resolution layers (1140) and combines the decoded higher-resolution information with the upsampled, decoded base layer pictures to form higher-resolution pictures (1150). Depending on the desired resolution level, the higher-resolution pictures may be full-resolution pictures or intermediate-resolution pictures. For more information, see, e.g., U.S. Patent No. 6,510,177, or the MPEG-2 standard or other video standards.

[0080] The decoder typically decodes pictures at one of the resolutions used in the encoder. Alternatively, the resolutions available to the decoder are not exactly the same as those used in the encoder.

IV. Resampling Filters for Scalable Video Coding and Decoding

[0081] This section describes techniques and tools for scalable video coding and decoding. Although some described techniques and tools are described in a layered (or spatial scalable) context, some described techniques and tools can also be used in a frame-based (or reference picture sampling) context, or in some other context that involves resampling filters. Further, although some described techniques and tools are described in the context of resampling pictures, some described techniques and tools can also be used for resampling residual or difference signals that result from prediction of higher resolution signals.

[0082] *Scalable video coding* (SVC) is a type of digital video coding that allows a subset of a larger bitstream to be decoded to produce decoded pictures with a quality that is acceptable for some applications (although such picture quality would be lower than the quality produced by decoding an entire higher-bit-rate bitstream). One well-known type of SVC is referred to as *spatial scalability*, or *resolution scalability*. In a spatial SVC design, the encoding process (or a pre-processing function to be performed prior to the encoding process, depending on the exact definition of the scope of the encoding process) typically includes downsampling the video to a lower resolution and encoding that lower-resolution video for enabling a lower-resolution decoding process, and upsampling of the lower-resolution decoded pictures for use as a prediction of the values of the samples in the pictures of the higher-resolution video. The decoding process for the higher-resolution video then includes decoding the lower-resolution video (or some part of it) and using that upsampled video as a prediction of the value of the samples in the pictures of the higher-resolution video. Such designs require the use of *resampling filters*. In particular, codec designs include the use of *upsampling filters* in both decoders and encoders and the use of *downsampling filters* in encoders or encoding pre-processors. We especially focus on the upsampling filters used in such designs. Typically, the upsampling process is designed to be identical in encoders and decoders, in order to prevent a phenomenon known as *drift*, which is an accumulation of error caused by the use of differing predictions of the same signal during encoding and decoding.

[0083] One drawback of some spatial SVC designs is the use of low-quality filters (e.g., two-tap bilinear filters) in the decoding process. The use of higher quality filters would be beneficial to video quality.

[0084] Spatial SVC may include resampling filters that enable a high degree of flexibility in the resampling ratio of the filter. However, this may require a large number of particular filter designs for each different "phase" of such a filter to be developed and the "tap" values of these filters to be stored in implementations of encoders and decoders.

[0085] Furthermore, it can be beneficial to video quality to allow an encoder to control the amount of blurriness of the resampling filters used for spatial SVC. Thus, for each "phase" of resampling to be designed for upsampling or downsampling, it may be beneficial to have several different filters to choose from, depending on the desired degree of blurriness to be introduced in the process. The selection of the degree of blurriness to be performed during upsampling may be sent from an encoder to a decoder as information conveyed for use in the decoding process. This extra flexibility further complicates the design, as it greatly increases the number of necessary tap values that may need to be stored in an encoder or decoder.

[0086] A unified design could be used to specify a variety of resampling filters with various phases and various degrees of blurriness. One possible solution is the use of the Mitchell-Netravali filter design method. Straightforward application of the Mitchell-Netravali filter design method to these problems may require excess computational resources in the form of an excessive dynamic range of possible values for quantities that are to be computed in the encoder or decoder. For example, one such design might require the use of 45-bit arithmetic processing, rather than the 16-bit or 32-bit processing elements normally used in general-purpose CPUs and DSPs. To address this issue, we provide some design refinements.

[0087] A typical SVC design requires a normative upsampling filter for spatial scalability. To support arbitrary resampling ratios (a feature known as *extended spatial scalability*), an upsampling filter design is described that incorporates a great deal of flexibility regarding resampling ratios. Another key aspect is the relative alignment of luma and chroma. Since a

variety of alignment structures (see, e.g., H.261/MPEG-1 vs. MPEG-2 alignment for 4:2:0 chroma, and H.264/MPEG-4 AVC) are found in single-layer approaches, described techniques and tools support a flexible variety of alignments, with an easy way for the encoder to indicate to the decoder how to apply the filtering appropriately.

[0088] Described techniques and tools comprise upsampling filters capable of high-quality upsampling and good anti-aliasing. In particular, described techniques and tools have quality beyond that provided by previous bilinear filter designs for spatial scalability. Described techniques and tools have high-quality upsampling filters that are visually pleasing as well as providing good signal-processing frequency behavior. Described techniques and tools comprise a filter design that is simple to specify and does not require large memory storage tables to hold tap values, and the filtering operations themselves are computationally simple to operate. For example, described techniques and tools have a filter that is not excessively lengthy and does not require excessive mathematical precision or overly complex mathematical functions.

[0089] This section describes designs having one or more of the following features:

- flexibility of luma/chroma phase alignment;
- flexibility of resampling ratio;
- flexibility of frequency characteristics;
- high visual quality;
- not too few and not too many filter taps (e.g., between 4 and 6);
- simple to specify;
- simple to operate (e.g., using practical word-length arithmetic).

A. Mitchell-Netravali Upsampling Filters

[0090] Described techniques and tools take a separable filtering approach - therefore, the following discussion will focus primarily on processing of a one-dimensional signal, as the two-dimensional case is a simple separable application of the one-dimensional case. It first proposes a two-parameter set of filters based on the conceptually-continuous impulse response $h(x)$ given by:

$$h(x) = \frac{1}{6} * \begin{cases} (12-9b-6c)|x|^3 - (18-12b-6c)|x|^2 + (6-2b) & |x| < 1 \\ -(b+6c)|x|^3 + (6b+30c)|x|^2 - (12b+48c)|x| + (8b+24c) & 1 \leq |x| < 2 \\ 0 & \text{otherwise} \end{cases} \quad (1),$$

where b and c are the two parameters. For a relative phase offset position $0 \leq x < 1$, this kernel produces a 4-tap finite impulse response (FIR) filter with tap values given by the following matrix equation:

$$\frac{1}{6} * [1 \quad x \quad x^2 \quad x^3]^* \begin{bmatrix} b & 6-2b & b & 0 \\ -(3b+6c) & 0 & 3b+6c & 0 \\ 3b+12c & -18+12b+6c & 18-15b-12c & -6c \\ -(b+6c) & 12-9b-6c & -(12-9b-6c) & b+6c \end{bmatrix} \quad (2)$$

Actually, it is sufficient to consider only the range of x from 0 to 1/2, since the FIR filter kernel for x is simply the FIR filter kernel for $1-x$ in reverse order.

[0091] This design has a number of interesting and useful properties. Here are some of them:

- No trigonometric functions, transcendental functions or irrational-number processing is needed to compute the filter tap values. In fact, tap values for such a filter can be directly computed with only a few simple operations. They do not need to be stored for the various possible values of the parameters and phases that are to be used; they can simply be computed when needed. (So, to standardize the use of such filters, only a few formulas are needed - no huge tables of numbers or standardized attempts to approximate functions like cosines or Bessel functions are needed.)
- The resulting filter has 4 taps. This is a very practical number.
- The filter has only a single sidelobe on each side of the main lobe. It thus will not produce excessive ringing artifacts.
- The filter has a smooth impulse response. Its value and its first derivative are both continuous.
- It has unity gain DC response, meaning that there is no overall brightness amplification or attenuation in the information being upsampled.

- Members of this family of filter include relatively good approximations of well-known good filters such as the "Lanczos-2" design and the "Catmull-Rom" design.

Furthermore, described techniques and tools include a particular relationship between the two parameters for the selection of visually-pleasing filters. That relationship can be expressed as follows:

$$c = \frac{1}{2}(1 - b) \quad (3)$$

This reduces the degrees of freedom to a single bandwidth control parameter b . This parameter controls the degree of extra blurriness introduced by the filter. Note that the member of this family associated with the value $b = 0$ is the excellent and well-known Catmull-Rom upsampling filter (also known as a Keys "cubic convolution" interpolation filter).

[0092] The Catmull-Rom upsampling filter has a number of good properties of its own, in addition to the basic advantages found for all members of the Mitchell-Netravali filter family:

- It is an "interpolating" filter - i.e., for phase values of $x = 0$ and $x = 1$, the filter has a single non-zero tap equal to 1. In other words, an upsampled signal will pass exactly through the values of the input samples at the edges of each upsampled curve segment.
- If the set of input samples forms a parabola (or a straight line, or a static value), the output points will lie exactly on the parabolic curve (or straight line or static value).

In fact, in some ways, the Catmull-Rom upsampler can be considered the best upsampling filter of this length for these reasons - although introducing some extra blurring (increasing b) may sometimes be more visually pleasing. Also, introducing some extra blurring can help blur out low-bit-rate compression artifacts and thus act more like a Wiener filter (a well-known filter used for noise filtering) estimator of the true upsampled picture.

[0093] Simple substitution of Equation (3) into Equation (2) results in the following tap values:

$$\frac{1}{6} * [1 \quad x \quad x^2 \quad x^3] * \begin{bmatrix} b & 6-2b & b & 0 \\ -3 & 0 & 3 & 0 \\ 6-3b & -15+9b & 12-9b & -3+3b \\ -(3-2b) & 9-6b & -(9-6b) & 3-2b \end{bmatrix} \quad (4).$$

[0094] It has been reported that, based on subjective tests with 9 expert viewers and over 500 samples:

- a usable range is reported as $0 \leq b \leq 5/3$;
- $0 \leq b \leq 1/2$ is categorized as visually "satisfactory", with $b = 1/3$ reported as visually pleasing;
- $b > 1/2$ is categorized as "blurry," with $b = 3/2$ reported as excessively blurry

B. Integerization of the Bandwidth Control Parameter

[0095] The division by 6 in the Equation (4) may not be desirable. It may be desirable instead to integerize the bandwidth control parameter and filter tap values, as infinite precision is impractical as part of a decoder design. Consider a substitution using a new integer-valued variable a defined as follows:

$$a = (b/6) * 2^S \quad (5),$$

where S is an integer shift factor and a is an unsigned integer acting as an integerized bandwidth control parameter. The parameter a can be encoded as a syntax element by the encoder at the video sequence level in a bitstream. For example, the parameter a can be encoded explicitly with a variable-length or fixed-length code, jointly coded with other information, or signaled explicitly. Alternatively, the parameter a is signaled at some other level in a bitstream.

[0096] The integerization results in integerized tap values of

$$\begin{bmatrix} 1 & x & x^2 & x^3 \end{bmatrix} * \begin{bmatrix} a & 2^S - 2a & a & 0 \\ -2^{S-1} & 0 & 2^{S-1} & 0 \\ 2^S - 3a & -5 * 2^{S-1} + 9a & 2^{S+1} - 9a & -2^{S-1} + 3a \\ -(2^{S-1} - 2a) & 3 * 2^{S-1} - 6a & -(3 * 2^{S-1} - 6a) & 2^{S-1} - 2a \end{bmatrix} \quad (6)$$

The result would then need to be scaled down by S positions in binary arithmetic processing.

[0097] If a has a range of 0 to M, then b has a range from 0 to 6 * M / 2^S. Some possible useful choices for M include the following:

- M = 2^(S-2) - 1, resulting in a range of b from 0 to 3/2 - 6/2^S.
- M = Ceil(2^S / 6), which returns the smallest integer greater than or equal to 2^S / 6, resulting in range of b from 0 to slightly more than 1.
- M = 2^(S-3) - 1, resulting in an approximate range of b from 0 to 3/4 - 6/2^S.

These choices for M are large enough cover most useful cases, with the first choice (M = 2^(S-2) - 1) being the larger of the three choices. A useful range for S is between 6 and 8. For example, consider S = 7 and M = 2^(S-2) - 1, i.e., M = 31. Alternatively, other values of M and S can be used.

C. Integerization of the Fractional-Sample Positioning

[0098] Next we consider the granularity of the value of x. For practicality, we should approximate x as well. For example, we can define an integer i such that:

$$x = i \div 2^F \quad (7)$$

where F represents a supported fractional-sample position precision. For an example of a sufficiently-accurate resampling operation, consider F ≥ 4 (one-sixteenth or greater sample positioning precision). This results in the following integerized filter tap values:

$$\begin{bmatrix} 1 & i & i^2 & i^3 \end{bmatrix} * \begin{bmatrix} a * 2^{3F} & (2^S - 2a) * 2^{3F} & a * 2^{3F} & 0 \\ -2^{2F+S-1} & 0 & 2^{2F+S-1} & 0 \\ (2^S - 3a) * 2^F & (-5 * 2^{S-1} + 9a) * 2^F & (2^{S+1} - 9a) * 2^F & (-2^{S-1} + 3a) * 2^F \\ -(2^{S-1} - 2a) & 3 * 2^{S-1} - 6a & -(3 * 2^{S-1} - 6a) & 2^{S-1} - 2a \end{bmatrix} \quad (8)$$

For example, consider F = 4. The result would then need to be scaled down by 3F+S positions.

[0099] Note that every entry in the matrix above contains a factor of two in common (assuming that S is greater than 1). Thus we can instead formulate the tap values as follows:

$$\begin{bmatrix} 1 & i & i^2 & i^3 \end{bmatrix} * \begin{bmatrix} a * 2^{3F-1} & (2^{S-1} - a) * 2^{3F} & a * 2^{3F-1} & 0 \\ -2^{2F+S-2} & 0 & 2^{2F+S-2} & 0 \\ (2^S - 3a) * 2^{F-1} & (-5 * 2^{S-1} + 9a) * 2^{F-1} & (2^{S+1} - 9a) * 2^{F-1} & (-2^{S-1} + 3a) * 2^{F-1} \\ -(2^{S-2} - a) & 3 * (2^{S-2} - a) & -3 * (2^{S-2} - a) & 2^{S-2} - a \end{bmatrix} \quad (9),$$

where each of the tap values have been divided by 2. The result then would need to be scaled down by only 3F+S-1 positions.

[0100] For the down-scaling, we define the function RoundingRightShift(p, R) as the output of a right shift of R bits (with rounding) computed for input value p, computed as follows:

$$\text{RoundingRightShift}(p, R) = \begin{cases} (p + 2^{R-1}) \gg R & \text{for } R = 2, 3, 4, \dots \\ (p) \gg R & \text{for } R = 0 \text{ or } 1 \end{cases} \quad (10)$$

where the notation ">>" refers to a binary arithmetic right shift operator using two's complement binary arithmetic. Alternatively, rounding right shifting is performed differently.

[0101] Some example applications for rounding right shifting are provided below.

5 D. Dynamic Range Consideration

[0102] If we filter pictures with N bits of sample bit depth and do so two-dimensionally before performing any rounding, we will need $2*(3F+S-1)+N+1$ bits of dynamic range in the accumulator prior to down-shifting the result by $2*(3F+S-1)$ positions and clipping the output to an N bit range. For example, if we have $F = 4$, $S = 7$ and $N = 8$, we may need to use a 45-bit accumulator to compute the filtered result.

[0103] We describe some approaches to mitigating this problem in the following subsections. These approaches can be used separately or in combination with each other. It should be understood that variations of the described dynamic range mitigation approaches are possible based on the descriptions herein.

15 1. First Example Dynamic Range Mitigation Approach

[0104] Consider an example where horizontal filtering is performed first, followed by vertical filtering. Consider a maximum word length of W bits for any point in the two-dimensional processing pipeline. In a first dynamic range mitigation approach, to accomplish the filtering we use a rounding right shift of R_H bits at the output of the first (horizontal) stage of the process and a rounding right shift of R_V bits at the output of the second (vertical) stage of the process.

[0105] We thus compute the following:

$$2 * (3F + S - 1) + N + 1 - R_H = W \quad (11),$$

and therefore

$$R_H = 2 * (3F + S - 1) + N + 1 - W \quad (12).$$

Then the right shift for the second (vertical) stage can be computed from

$$R_H + R_V = 2 * (3F + S - 1) \quad (13),$$

and therefore

$$R_V = 2 * (3F + S - 1) - R_H. \quad (14).$$

For example, for $F = 4$ and $S = 7$ and $N = 8$ and $W = 32$, we obtain $R_H = 13$ and $R_V = 23$. Thus, instead of 45 bits of dynamic range, with rounding right shifts the dynamic range is reduced to 32 bits. Right shifts of different numbers of bits can be used for different values of W .

45 2. Second Example Dynamic Range Mitigation Approach

[0106] A second dynamic range mitigation approach involves reducing the precision of the tap values rather than reducing the precision of the phase positioning (i.e., reducing F), reducing the granularity of the filter bandwidth adjustment parameter (i.e., reducing S) or reducing the precision of the output of the first stage (i.e., increasing R_H).

[0107] We denote the four integer tap values produced by Equation (9) as $[t_{-1}, t_0, t_1, t_2]$. Note that the sum of the four filter tap values will be equal to 2^{3F+S-1} , i.e.,

$$t_{-1} + t_0 + t_1 + t_2 = 2^{3F+S-1} \quad (15).$$

This is an important property of this example dynamic range mitigation approach because whenever all four input samples have the same value, the output will have that same value.

[0108] Using the example definition of rounding right shifting found in Equation (10), and given a right shift quantity

R_t for the tap values, we define the following:

$$u_{-1} = \text{RoundingRightShift}(t_{-1}, R_t);$$

$$u_1 = \text{RoundingRightShift}(t_1, R_t);$$

$$u_2 = \text{RoundingRightShift}(t_2, R_t);$$

$$u_0 = 2^{3F+S-1} - u_{-1} - u_1 - u_2.$$

We then perform the filtering with tap values $[u_{-1}, u_0, u_1, u_2]$ rather than $[t_{-1}, t_0, t_1, t_2]$. Each increase of 1 in the value of R_t represents one less bit of dynamic range necessary in the arithmetic accumulator, and one less bit of right-shifting to be performed in subsequent stages of processing.

3. Third Example Dynamic Range Mitigation Approach

[0109] One previous design uses a trick that is similar in concept but differs from the first example dynamic range mitigation approach in that it makes the amount of right-shifting after the first stage of the process a function of the value of the phase positioning variable i .

[0110] We can recognize that the filter tap values shown in Equation (9) will contain K zero-valued LSBs when the value of i is an integer multiple of 2^K . Thus, if the second stage of the filtering process uses a phase positioning variable i that is an integer multiple of 2^K , we can right-shift the tap values of the second stage by K bits and decrease the amount of right shifting for the first stage by K bits.

[0111] This might get rather difficult to keep track of when operating a generalized resampling factor. However, when performing simple resampling factors of 2:1 or other simple factors, it is easy to recognize that all phases in use for the second stage of the filtering process contain the same multiple of 2^K , allowing this approach to be applied in these special cases.

V. Position Calculation Techniques and Tools

[0112] Techniques and tools for computing positioning information for spatial SVC are described.

[0113] Some techniques and tools are directed to how to focus on a word length B and optimize the precision of the computation within the constraint of that word length. Instead of just selecting the precision and requiring some necessary word length, applying the new method will result in higher precision in a real implementation and will broaden the range of effective application of the technique, because it uses all of the available word length to maximize the accuracy within that constraint.

[0114] Some techniques and tools are directed to a) offsetting the origin of the coordinate system and b) using unsigned integers rather than signed integers in order to achieve a better trade-off between precision and word length/dynamic range. A minor increase in computations is needed to add the origin offset term to each calculated position.

[0115] Some techniques and tools are directed to breaking the computation of different sections of the string of samples to be produced into different stages of processing, wherein the origin of the coordinate system is changed at the start of each stage. Again it provides a better trade-off between precision and word length/dynamic range with another minor increase in computational requirements (since certain extra computations are performed at the start of each stage). If the technique is taken to its logical extreme, the need for multiplication operations can be eliminated and the trade-off between precision and word length/dynamic range can be further improved. However, certain extra operations would need to be performed for every sample (since the extra computation needed for "each stage" becomes needed for every sample when every stage contains only one sample).

[0116] As a general theme, designs are described for the position calculation part of the processing to achieve desirable trade-offs between precision of the computed results, word length/dynamic range of the processing elements, and the number and type of mathematical operations involved in the processing (e.g., shift, addition and multiplication operations).

[0117] For example, described techniques and tools allow flexible precision calculations using B -bit (e.g., 32-bit) arithmetic. This allows a spatial SVC encoder/decoder to flexibly accommodate different image sizes without having to convert to different arithmetic (e.g., 16-bit or 64-bit arithmetic) for calculations. With the flexible precision B -bit (e.g., 32-bit) arithmetic, an encoder/decoder can devote a flexible number of bits to the fractional component. This allows increased precision for calculations as the number of required bits for representing the integer component decreases (e.g., for a smaller frame size). As the number of required bits for representing the integer component increases (e.g., for a larger frame size), the encoder/decoder can use more bits for the integer component and less bits for the fractional component, reducing precision but maintaining the B -bit arithmetic. In this way, changing between different precisions and different frame sizes is greatly simplified.

[0118] This section includes specific details for an example implementation. However, it should be noted that the specifics described herein can be varied in other implementations according to principles described herein.

A. Introduction and Position Calculation Principles

[0119] Techniques for computing position and phase information, resulting in much lower computational requirements without any significant loss of accuracy, are described. For example, described techniques can reduce computational requirements significantly - e.g., by reducing nominal dynamic range requirements dramatically (by tens of bits). Considering the variety of possible chroma positions that may be used in base and enhancement layers, it is desirable to find a solution providing proper positioning of resampled chroma samples relative to luma samples. Accordingly, described techniques allow adjustments to be made to calculate positions for video formats with different relationships between luma and chroma positions.

[0120] A previous upsampling method designed for extended spatial scalability uses a rather cumbersome method of calculating the position and phase information when upsampling the low-resolution layer; it scales an up-shifted approximate inverse of a denominator, which causes amplification of the rounding error in the inversion approximation as the numerator increases (i.e., as the upsampling process moves from left to right, or from top to bottom). By comparison, techniques described herein have excellent accuracy and simplify computation. In particular, techniques are described that reduce the dynamic range and the amount of right-shifting in the position calculations by tens of bits.

[0121] For example, a technique is described for computing the positioning information for obtaining an integer position and a phase positioning variable i , where $i = 0..2^F - 1$, for use in SVC spatial upsampling.

[0122] Described techniques apply the resampling process to the application of spatial scalable video coding rather than to forward reference picture resampling. In this application of spatial scalable video coding, certain simplifications can apply. Rather than a general warping process, we only need a picture resizing operation. This can be a separable design for each dimension.

B. Position Calculation Design

[0123] Consider a problem statement, in each dimension (x or y), as the production of a string of samples lying conceptually in a real-valued range from L to $R > L$ in the new (upsampled) array. This real-valued range is to correspond to a range from L' to $R' > L'$ in the referenced lower-resolution array.

[0124] For a position T in the new array where $L \leq T \leq R$, we then need to compute the position in the reference array that corresponds to the position in the new array. This would be the position $T' = L' + (T - L) * (R' - L') \div (R - L)$.

[0125] Now instead of considering the resizing of the range from L to R , we define an integer $M > 0$ and consider resizing the range from L to $L + 2^M$ by the same resizing ratio $(R' - L') \div (R - L)$. The corresponding range in the referenced sample coordinates are then from L' to R'' , where $R'' = L' + 2^M * (R' - L') \div (R - L)$. If M is sufficiently large, i.e., if $M \geq \text{Ceil}(\text{Log}_2(R - L))$, then $R'' \geq R'$. (Let us assume for now that this constraint holds in order to explain the concepts below, although this constraint is not really necessary for proper functioning of the equations.)

[0126] Now we can use linear interpolation between the positions L' and R'' for the positioning calculations. Position L is mapped to position L' , and position $T \geq L$ is mapped to position $((2^M - (T - L)) * L' + (T - L) * R'') \div 2^M$. This converts the denominator of the operation to a power of 2, thus reducing the computational complexity of the division operation by allowing it to be replaced by a binary right shift.

[0127] Appropriate modifications can be made to integerize the computations. We round the values of L' and R'' to integer multiples of $1 \div 2^G$, where G is an integer, such that L' is approximated by $k \div 2^G$ and R'' is approximated by $r \div 2^G$ where k and r are integers. Using this adjustment, we have position T mapped to position

$$((2^M - (T - L)) * k + (T - L) * r) \div 2^{(M+G)}.$$

[0128] Now we assume that the relevant values of T and L are integer multiples of $1 \div 2^J$, where J is an integer, such that $T - L = j \div 2^J$. Using this adjustment, we have position T mapped to position

$$((2^{(M+J)} - j) * k + j * r) \div 2^{(M+G+J)}.$$

[0129] Recall from section IV, above, that the fractional phase of the resampling filter is to be an integer in units of $1 \div 2^F$. So the computed position, in these units, is $\text{Round}(((2^{(M+J)} - j) * k + j * r) \div 2^{(M+G+J-F)})$, or

$$t' = ((2^{(M+J)} - j) * k + j * r + 2^{(M+G+J-F-1)}) \gg (M + G + J - F) \quad (16),$$

or, more simply,

$$t' = (j * C + D) \gg S \quad (17),$$

where

$$S = M + G + J - F \quad (18),$$

$$C = r - k \quad (19),$$

$$D = (k \ll (M+J)) + (1 \ll (S-1)) \quad (20).$$

[0130] The only error produced in the method described here (assuming no error in the representation of L and R and L' and R') prior to the rounding of the computed position to the nearest multiple of $1 \div 2^F$ (which is an error that is present in both designs) is the rounding error from the rounding of the position R'' to the nearest multiple of $1 \div 2^G$. This amount is very small if $G + M$ is relatively large. In fact, this source of error is tightly bounded to a magnitude of about $(T - L) \div 2^{(G+M+1)}$, the word length requirements for computation of the results are modest, and the modulo arithmetic allows the integer part of the result to be separated out to minimize word length, or allows the computation to be decomposed in other similar ways as well.

[0131] F can, for example, be 4 or greater. (For some applications, $F = 3$ or $F = 2$ may suffice.) Example values of J include $J = 1$ for luma position calculations and $J = 2$ for chroma sample positions. Rationale for these example values of J can be found below.

1. First Example Simplified Position Calculation Technique Using Signed B -bit Arithmetic

[0132] If $R' > 0$ and $L' > -R'$, then all positions t' to be computed in the picture to be upsampled, as an integer in units of $1 \div 2^F$, will lie between -2^Z and $2^Z - 1$, where $Z = \text{Ceil}(\text{Log}_2(R')) + F$. If the word length of the $(j * C + D)$ computation is B bits, and we assume the use of signed two's complement arithmetic, then we can require that $B - 1 \geq Z + S$. High accuracy is achieved if this constraint is tight, i.e., if $B - 1 = Z + M + G + J - F$.

[0133] For reasonably-small picture sizes (e.g., for levels up to level 4.2 in the current H.264/MPEG-4 AVC standard), $B = 32$ can be used as a word length. Other values of B also can be used. For very large pictures, a larger B may be used. The computations can also be easily decomposed into smaller word length sub-computations for use on 16-bit or other processors.

[0134] The remaining two degrees of freedom are M and G . Their relationship is flexible, as long as G is sufficiently large to avoid any need for rounding error when representing L' as $k \div 2^G$. Thus, based on issues discussed in the next section for SVC, we can just pick $G = 2$, yielding

$$M = B + F - (G + J + Z + 1)$$

i.e.,

$$M = 32 + 4 - (2 + 1 + Z + 1)$$

i.e.,

$$M = 32 - Z.$$

[0135] For example, if we want to upsample the luma array of a picture that has a width of 1000 luma samples with

$B = 32$ and $L' = 0$, we can use $F = 4$, $G = 2$, $J = 1$, $M = 18$, $S = 17$, and $Z = 14$ using this first example position calculation technique.

[0136] When T is very close (or equal) to R and R' is very close (or equal) to an integer power of 2, especially when $(T - L) * (R' - L) \div 2^F$ is large (e.g., greater than 1/2), it may be hypothetically possible for the upper bound to be violated by 1. We do not further consider such cases here, although adjustments to handle such cases are straightforward.

2. Second Example Position Calculation Technique Using Unsigned B-bit Arithmetic

[0137] If all positions to be calculated in the low-resolution picture are greater than or equal to 0, which is something that can be made true by adding an appropriate offset to the origin of the coordinate system, then it may be a better choice to compute $t' = (j * C + D)$ using unsigned integer arithmetic rather than signed two's complement arithmetic. This allows one more bit of dynamic range without overflow in the computations (i.e., we can use B bits of dynamic range magnitude rather than $B - 1$ bits), thus increasing M (or G) and S each by 1 and further increasing the accuracy of the computed results. Thus, after including an offset E to adjust the origin of the coordinate system, the form of the computation would be $t' = ((j * C + D) \gg S) + E$ rather than just $t' = (j * C + D) \gg S$.

[0138] We provide further detail on this more accurate method involving unsigned arithmetic by identifying when the origin offset E would not be needed as follows.

- Choose values for B , F , G , J , and Z as described above.
- Set $M = B + F - (G + J + Z)$.
- Compute S , C , and D as specified above in Equations (18), (19) and (20), respectively, where D is computed as a signed number.
- If D is greater than or equal to zero, no origin offset (i.e., no use of E) is needed and the computation can be performed simply as $t' = (j * C + D) \gg S$ using unsigned arithmetic and the result will have greater accuracy than the first example position calculation technique described in section V.B.1 above.

[0139] In addition to enhancing accuracy by enabling computation using unsigned integers, offsetting the origin can sometimes also be used to provide improved accuracy by enabling a decrease in the value of Z . Without the origin offset, Z is a function of R' . But with the origin offset, we can make Z a function of $R' - L'$, which will make the computation more accurate if this results in a smaller value of Z .

[0140] We provide further detail on this more accurate method involving unsigned arithmetic by showing one way to offset the origin, deriving D' and E as follows.

- Choose values for B , F , G , and J , as described above.
- Set $Z = \text{Ceil}(\text{Log}_2(R' - L')) + F$.
- Set $M = B + F - (G + J + Z)$.
- Compute S , C , and D as specified above in Equations (18), (19) and (20), respectively, where D is computed as a signed number.
- Set $E = D \gg S$.
- Set $D' = D - (E \ll S)$.
- The position computation can then be performed as $t' = ((j * C + D') \gg S) + E$.

[0141] If D' and E (and M , S , and Z) are computed in this manner, the mathematical result of the equation $t' = ((j * C + D') \gg S) + E$ will actually always be theoretically the same as the result of the equation $t' = (j * C + D) \gg S$, except that the value of $(j * C + D)$ may sometimes fall outside of the range of values from 0 to $2^B - 1$, while the value of $(j * C + D')$ will not.

[0142] For example, if we want to upsample the luma array of a picture that has a width of 1000 luma samples with $B = 32$ and $L' = 0$, we can use $F = 4$, $G = 2$, $J = 1$, $M = 19$, $S = 18$, and $Z = 14$ using this second example position calculation technique. Another possibility that would work equally well, rather than offsetting the origin so that all values of $j * C + D'$ are non-negative and thus allowing use of the B -bit computing range from 0 to $2^B - 1$ using unsigned arithmetic, would be to offset the origin further to the right by another $2^{(B-1)}$ to allow use of the B -bit computing range from $-2^{(B-1)}$ to $2^{(B-1)} - 1$ using signed arithmetic.

[0143] As in the first example position calculation technique in the previous section, there could be "corner case" adjustments needed when T is very close (or equal) to R and $R' - L'$ is very close (or equal) to an integer power of 2.

3. Example Multi-Stage Techniques for Position Calculation

[0144] We have discussed methods in which the design was made to be able to perform the computation using the

same equation, e.g., $t' = ((j * C + D') \gg S) + E$, with the same variable values C , D' , S , and E for all values of j covering the range of samples to be generated (i.e., for all values of T between L and R). We now discuss how this assumption can be relaxed, enabling greater accuracy and/or reduced computational dynamic range requirements.

[0145] Ordinarily, the resampling process proceeds from left to right (or top to bottom) to generate a string of consecutive samples at equally-spaced positions. In the second example position technique described in section V.B.2 above, we showed how changing the origin using the offset parameter E can be used to make good use of the B -bit dynamic range of the register used to compute the $(j * C + D')$ part of the position computation.

[0146] Recall that in the previous section, only the S least significant bits of D were retained in D' , and the rest was moved into E . Thus the major remaining issue for computation of $(j * C + D')$ is the magnitude of $j * C$.

[0147] Recall that T and L are integer multiples of $1 \div 2^J$. Ordinarily we perform the upsampling process to generate a string of samples at integer-valued increments in the higher-resolution picture, e.g., with a spacing of 2^J between consecutively-generated samples. Thus we desire to compute the positions t'_i that correspond to the positions $T_i = (p + i * 2^J) \div 2^J$ for $i = 0$ to $N - 1$ for some value of p and N .

[0148] This process can be summarized in pseudo-code as shown in the pseudo-code 1200 of Figure 12 for some value of p and N . As i increases toward N , the value of q increases, and the maximum value of q should be kept within the available dynamic range of B bits. The maximum value computed for q is $(p + (N - 1) * 2^J) * C + D'$.

[0149] Now, instead of generating all samples in one loop in this fashion, consider breaking up the process into multiple stages, e.g., two stages. For example, in a two stage process, the first stage generates the first $N_0 < N$ samples, and the second stage generates the remaining $N - N_0$ samples. Also, since p is a constant with respect to the loop, we can move its impact into D' and E before the first stage. This results in a two-stage process illustrated in pseudo-code 1300 in Figure 13.

[0150] At the beginning of each stage in pseudo-code 1300, the origin has been reset such that all but the S least significant bits of the first value of q for the stage have been moved into E (i.e., into E_0 for the first stage and E_1 for the second stage). Thus, during operation of the each of the two stages, q requires a smaller dynamic range. After breaking the process into stages in this fashion, the maximum value of q will be $N_0 * C' + D_0$, or $((N - N_0 - 1) * C' + D_1)$, whichever is larger.. But since D_0 and D_1 each have no more than S bits of unsigned dynamic range, this will ordinarily be a smaller maximum value than in the previously-described single-stage design. The number of samples generated in the stage (i.e., N_0 for the first stage and $N - N_0$ for the second stage) can affect the dynamic range for the associated computations. For example, using a smaller number of samples in each stage will result in a smaller dynamic range for the associated computations.

[0151] Each stage can be split further into more stages, and thus the generation of the N total samples can be further decomposed into any number of such smaller stages. For example, the process could be broken up into stages of equal size so that blocks of, e.g., 8 or 16 consecutive samples are generated in each stage. This technique can either be used to reduce the necessary number of bits of dynamic range B for computing q or to increase the precision of the computation (increasing S and $G+M$) while keeping the dynamic range the same, or a mixture of these two benefits.

[0152] This technique of decomposing the position calculation process into stages can also be used to perform a continuous resampling process along a very long string of input samples (conceptually, the string could be infinitely long), such as when performing sampling rate conversion as samples arrive from an analog-to-digital converter for an audio signal. Clearly, without breaking up the process into finite-size stages and resetting the origin incrementally from each stage to the next, an infinitely-long string of samples could not be processed by the techniques described in the previous sections, since this would require an infinite dynamic range in the processing word length. However, the difficulty in applying the techniques to effectively-infinite string lengths is not a substantial limitation on such techniques since the application to effectively-infinite length would only be useful when no rounding error is entailed by the representation of the hypothetical benchmark positions L' and R'' in integer units representing multiples of $1 \div 2^G$.

[0153] Under the circumstances in which multi-stage position calculation techniques can be applied, they provide a way for the computations to be performed along an infinite-length string of samples with no "drifting" accumulation of rounding error whatsoever in the operation of the position calculations throughout the entire rate conversion process.

4. Example Incremental Operation of Position Calculation

[0154] An interesting special case for the multi-stage decomposition concept described above is when the number of samples to be produced in each stage has been reduced all the way to just one sample per stage. The pseudo-code 1400 in Figure 14 represents a process for generating N positions t'_i for $i = 0$ to $N - 1$.

[0155] Since the process is described as an upsampling process (although the same principles could also apply to a downsampling process), we know that for each increment of i there is a spacing of 1 in the higher-resolution picture and therefore there is an increment of less than or equal to 1 in the lower-resolution picture. An increment of 1 in the spatial position in the lower-resolution picture corresponds to a value of $2^{(S+F)}$ for C' . Also, we know that $D' < 2^S$. Therefore $q = C' + D'$ has a range from 0 to less than $2^{(S+F)} + 2^S$, and therefore q can be computed with a dynamic range requirement

of no more than $B = S + F + 1$ bits using unsigned integer arithmetic. In one implementation, this dynamic range requirement is invariant to picture size (i.e., it does not depend on the value of R' or $R' - L'$).

[0156] For scalable video coding and many other such applications, there may be no real need to support upsampling ratios that are very close to 1. In such applications, we can assume that C' actually requires no more than $S + F$ bits.

[0157] For example, if we want to upsample the luma array of a picture that has a width of 1000 luma samples with $B = 32$ and $L' = 0$, we can use $F = 4$, $G = 2$, $J = 1$, $M = 29$, $S = 28$, and $Z = 14$ using this method. The result would be so extraordinarily precise as to make a smaller value of B seem like a more reasonable choice.

[0158] Alternatively, if we want to upsample the luma array of a picture that has a width of 1000 luma samples with $B = 16$ and $L' = 0$, we can use $F = 4$, $G = 2$, $J = 1$, $M = 13$, $S = 12$, $Z = 14$ using this method.

[0159] Further knowledge of the circumstances of the upsampling operation to be performed may provide further optimization opportunities. For example, if the upsampling ratio is significantly greater than two, the dynamic range requirement will be reduced by another bit, and so on for upsampling ratios greater than four, sixteen, etc.

[0160] None of the changes (relative to the example multi-stage position calculation technique discussed above) described with reference to the example incremental position calculation technique in this section affect the actual computed values of the positions t'_i for given values of C , D and S . Only the dynamic range necessary to support the computation is changed.

[0161] The inner loop in pseudo-code 1400 for this form of decomposition does not require *any* multiplication operations. This fact may be beneficial to providing reduced computation time on some computing processors.

5. Additional Remarks

[0162] For common resampling ratios such as 2:1, 3:2, etc. - any case in which no rounding would be necessary for approximating the positions L' and R'' as an integer in units of $1 \div 2^G$ - there is no rounding error at all when using these methods (other than whatever rounding error may be induced when rounding the final result to an integer in units of $1 \div 2^F$, which is an error that would be present regardless of the position computation method).

C. Luma and Chroma Positions and Relationships

[0163] Assuming exact alignment of the complete new (upsampled) picture and the reference picture arrays, relative

to the luma sampling grid index coordinates, the positions L and R in the current picture coordinates are $L = -\frac{1}{2}$ and

$$R = W - \frac{1}{2},$$

where W is the number of samples in the image vertically or horizontally, depending on the relevant resampling dimension. Equivalently, we could set the origin of the image spatial coordinate system a half-sample to the left of (or above) the position of grid index 0 and add $1/2$ when converting from image spatial coordinates to grid index values, thus avoiding the need to deal with negative numbers when performing computations in the spatial coordinate system.

[0164] The positions L' and R' in the referenced (lower-resolution) picture are referenced to the sampling grid coordinates in the same way, where in this case W is the number of samples in the referenced picture rather than in the new picture.

[0165] For the chroma sampling grid (whether in the new picture or the referenced picture), the situation is somewhat less straightforward. To construct the designated alignment of chroma samples relative to luma, consider the image rectangle that is represented by the chroma samples to be the same as the rectangle that is represented by the luma samples. This produces the following cases:

- Horizontally, for 4:2:0 chroma sampling types 0, 2, and 4 (see Figure 5D), the current picture coordinates are defined

$$L = -\frac{1}{4} \quad R = W - \frac{1}{4}.$$

- Horizontally, for 4:2:0 chroma sampling types 3, 1, and 5 (see Figure 5D), the current picture coordinates are defined

$$L = -\frac{1}{2} \quad R = W - \frac{1}{2}.$$

- Vertically, for 4:2:0 chroma sampling types 2 and 3 (see Figure 5D), the current picture coordinates are defined by

$$L = -\frac{1}{4} \quad R = W - \frac{1}{4}.$$

- Vertically, for 4:2:0 chroma sampling types 0 and 1 (see Figure 5D), the current picture coordinates are defined by

$$L = -\frac{1}{2} \quad \text{and} \quad R = W - \frac{1}{2}.$$

- Vertically, for 4:2:0 chroma sampling types 4 and 5 (see Figure 5D), the current picture coordinates are defined by

$$L = -\frac{3}{4} \quad \text{and} \quad R = W - \frac{3}{4}.$$

- Horizontally, for 4:2:2 chroma sampling, the current picture coordinates for the 4:2:2 sampling typically used in

$$L = -\frac{1}{4} \quad \text{and} \quad R = W - \frac{1}{4}.$$

- Vertically, for 4:2:2 chroma sampling, the current picture coordinates for the 4:2:2 sampling typically used in industry

$$L = -\frac{1}{2} \quad \text{and} \quad R = W - \frac{1}{2}.$$

- Both horizontally and vertically, for 4:4:4 chroma sampling, the current picture coordinates are defined by $L = -\frac{1}{2}$

$$\text{and} \quad R = W - \frac{1}{2}.$$

[0166] Again an offset can be used to place the origin of the coordinate system sufficiently to the left of position L and avoid the need to work with negative numbers.

[0167] The integer coordinates and the fractional phase offset remainder are computed by adjusting the integer coordinate positions of the samples to be produced in the upsampled array to compensate for the fractional offset L , and then applying the transformation shown at the end of section V.B. Conceptually, shifting the result to the right by F bits results in the integer coordinate pointer into the reference picture, and subtracting the left-shifted integer coordinate (shifted by F bits) provides the phase offset remainder.

D. Extra Precision for Position Calculation for Upsampling

[0168] This section describes how to map the position calculation method of section V.C.4 above to a specific upsampling process, such as an upsampling process that may be used for the H.264 SVC Extension. The position calculation is applied in a very flexible way to maximize the precision for both luma and chroma channels at various chroma formats as well as for both progressive and interlace frame formats. The techniques described in this section can be varied depending on implementation and for different upsampling processes.

[0169] In the above-described position calculations (in above sections V.A-C), the rescaling parameter (which is the variable C , and hereafter labeled deltaX (or delta Y) in the following equations) is scaled up by a scaling factor equal to 2^J (where $J = 1$ for luma and 2 for chroma) to form the increment added for generating each sample position from left to right or top to bottom. The scaling was selected such that the up-scaled increment will fit into 16 bits.

1. Maximum precision for scaling position computation

[0170] A *direct* way to apply the position calculation method is to scale up the rescaling parameter by a scaling factor equal to 2^J , where $J = 1$ for luma and 2 for chroma, to form the increment added for generating each sample position from left to right or top to bottom. The scaling parameters are then selected to ensure that the up-scaled increment will fit into a specific word length such as 16 bits. A more flexible design is described in the following sections to maximize the position precisions.

a. Luma Channel

[0171] The "direct" luma position calculation method can be summarized with the following example equations for $F = 4$ and $S = 12$ (along the horizontal direction):

$$\text{deltaX} = \text{Floor} \left(\left(\text{BasePicWidth} \ll 15 \right) + \left(\text{ScaledBaseWidth} \gg 1 \right) \right) \div \text{ScaledBaseWidth}$$

$$xf = ((2 * (xP - ScaledBaseLeftOffset) + 1) * deltaX - 30720) >> 12$$

[0172] Here, BasePicWidth is the horizontal resolution of the base-layer or low-resolution picture; ScaledBaseWidth is the horizontal resolution of the high-resolution picture region or window; deltaX is the intermediate rescaling parameter, which in this case is a rounded approximation of 32768 times the inverse of the upsampling ratio; xP represents the sample position in the high-resolution picture; ScaledBaseLeftOffset represents the relative position of the picture window in the high-resolution picture, and Floor() denotes the largest integer less than or equal to its argument. The constant value 30720 results from adding 2^{S-1} as the rounding offset prior to the right shift and subtracting $2^S * 2^F / 2$ for the half-sample offset of the luma sampling grid reference location as discussed at the beginning of section V.C above.

[0173] It is noteworthy that each increment of xP results in an increment of $2 * deltaX$ inside the equations. And, the LSB of the quantity $2 * deltaX$ is always zero, so one bit of computational precision is essentially being wasted. Approximately one extra bit of precision can be obtained, without any significant increase in complexity, by changing these equations to:

$$deltaX = \text{Floor} \left(\left(\text{BasePicWidth} \ll 16 \right) + \left(\text{ScaledBaseWidth} \gg 1 \right) \right) \div \text{ScaledBaseWidth}$$

$$xf = \left(\left(xP - \text{ScaledBaseLeftOffset} \right) * deltaX + \left(deltaX \gg 1 \right) - 30720 \right) \gg 12$$

or a (slightly) more accurate form as follows:

$$deltaXa = \text{Floor} \left(\left(\text{BasePicWidth} \ll 16 \right) + \left(\text{ScaledBaseWidth} \gg 1 \right) \right) \div \text{ScaledBaseWidth}$$

$$deltaXb = \text{Floor} \left(\left(\text{BasePicWidth} \ll 15 \right) + \left(\text{ScaledBaseWidth} \gg 1 \right) \right) \div \text{ScaledBaseWidth}$$

$$xf = \left(\left(xP - \text{ScaledBaseLeftOffset} \right) * deltaXa + deltaXb - 30720 \right) \gg 12$$

[0174] The latter of these two forms is suggested due to its higher accuracy and negligible complexity impact (although the precision difference also seems very small).

[0175] Note that on processing architectures on which division calculations are difficult to perform, having the result of one of these equations can simplify the computation of the other. The value of deltaXa will always be in the range of $2 * deltaXa$ plus or minus 1. The following simplified rule can therefore be derived to avoid the need to perform a division operation for the computation of deltaXa:

```

deltaXa = (deltaXb << 1)
remainderDiff = (BasePicWidth << 16) + (ScaledBaseWidth >> 1) - deltaXa
if (remainderDiff < 0)
    deltaXa--
else if (remainderDiff >= ScaledBaseWidth)
    deltaXa++

```

b. Chroma Channels

[0176] A factor-of-four multiplier can be used for chroma channels instead of a factor-of-two multiplier in this part of the design to enable representation of the chroma positions for 4:2:0 sampling (using $J = 2$ for chroma rather than $J = 1$ as described for luma). Therefore the "direct" equations are:

$$\text{deltaXC} = \text{Floor} \left(\left(\text{BasePicWidthC} \ll 14 \right) + \left(\text{ScaledBaseWidthC} \gg 1 \right) \right) \div \text{ScaledBaseWidthC}$$

$$\begin{aligned} \text{xfC} = & \left(\left(\left(4 * \left(\text{xC} - \text{ScaledBaseLeftOffsetC} \right) + \right. \right. \right. \\ & \left. \left. \left(2 + \text{scaledBaseChromaPhaseX} \right) * \text{deltaXC} \right) \right. \\ & \left. \left. + 2048 \right) \gg 12 \right) - 4 * \left(2 + \text{baseChromaPhaseX} \right) \end{aligned}$$

[0177] Here, `baseChromaPhaseX` and `scaledBaseChromaPhaseX` represent chroma sampling grid position offsets for the low- and high-resolution pictures, respectively. The values of these parameters may be explicitly conveyed as information sent from the encoder to the decoder, or may have specific values determined by the application. All other variables are similar to that defined for the luma channel with additional "C" suffix to represent application to the chroma channel.

[0178] Each increment of `xC` results in an increment of $4 * \text{deltaXC}$ inside the equation. Therefore, approximately two extra bits of precision can be obtained, without any substantial increase in complexity, by changing these equations to:

$$\text{deltaXC} = \text{Floor} \left(\left(\text{BasePicWidthC} \ll 16 \right) + \left(\text{ScaledBaseWidthC} \gg 1 \right) \right) \div \text{ScaledBaseWidthC}$$

$$\begin{aligned} \text{xfC} = & \left(\left(\text{xC} - \text{ScaledBaseLeftOffsetC} \right) * \text{deltaXC} \right. \\ & \left. + \left(2 + \text{scaledBaseChromaPhaseX} \right) * \left(\left(\text{deltaXC} + K \right) \gg 2 \right) \right. \\ & \left. + 2048 \right) \gg 12 - 4 * \left(2 + \text{baseChromaPhaseX} \right) \end{aligned}$$

where $K = 0, 1, \text{ or } 2$. Using $K = 0$ would avoid an extra operation. Using $K = 1$ or $K = 2$ would have a little higher accuracy.

[0179] The corresponding, slightly more accurate form would be the following:

$$\text{deltaXCa} = \text{Floor} \left(\left(\text{BasePicWidthC} \ll 16 \right) + \left(\text{ScaledBaseWidthC} \gg 1 \right) \right) \div \text{ScaledBaseWidthC}$$

$$\text{deltaXCb} = \text{Floor} \left(\left(\text{BasePicWidthC} \ll 14 \right) + \left(\text{ScaledBaseWidthC} \gg 1 \right) \right) \div \text{ScaledBaseWidthC}$$

$$\begin{aligned} \text{xfC} = & \left(\left(\text{xC} - \text{ScaledBaseLeftOffsetC} \right) * \text{deltaXCa} + \right. \\ & \left. \left(2 + \text{scaledBaseChromaPhaseX} \right) * \text{deltaXCb} \right. \\ & \left. + 2048 \right) \gg 12 - 4 * \left(2 + \text{baseChromaPhaseX} \right) \end{aligned}$$

[0180] As with the luma case, the latter variant is preferred since the complexity difference seems negligible (although the precision difference also seems very small).

c. Interlaced Field Coordinates

[0181] The reference for the coordinate system of a picture is ordinarily based on half-sample positions in luma frame coordinates, thus resulting in the scale factor of two for luma coordinate reference positions as described above. A half-sample shift in luma frame coordinates corresponds to a quarter-sample shift in 4:2:0 chroma frame coordinates, which is why we currently use a factor of four rather than a factor of two in the scaling for the chroma coordinates as described above.

[0182] Horizontally there is no substantial difference in operations for coded pictures that represent a frame and those that represent a single field of interlaced video. However, when a coded picture represents a single field, a half-sample position shift in luma frame vertical coordinates corresponds to a quarter-sample position shift in luma field vertical

coordinates. Thus, a scale factor of four rather than two should be applied in the calculation of the vertical luma coordinate positions.

[0183] Similarly, when a coded picture represents a single field, a half-sample position shift in luma frame vertical coordinates corresponds to a one-eighth-sample position shift in the chroma field vertical coordinates. Thus, a scale factor of eight rather than four should be applied in the calculation of the vertical chroma coordinate positions.

[0184] These scaling factors for computation of vertical coordinate positions in coded field pictures can be incorporated into a deltaY vertical increment computation in the same manner as described above for the increment computation in coded frame pictures. In this case, due to the increased scaling factor that is applied, the precision improvement becomes approximately two bits of added precision for luma positions and three bits of added precision for chroma (vertically).

2. 4:2:2 and 4:4:4 Chroma Restriction and Refinement

[0185] The position calculation method of section V.D.1.b requires use of a different multiplication factor for chroma than for luma. This makes sense for 4:2:0 video and it is also reasonable for 4:2:2 video horizontally, but it is not necessary for 4:2:2 video vertically or for 4:4:4 video either horizontally or vertically, since in those cases the luma and chroma resolution is the same and the luma and chroma samples are therefore presumably co-located.

[0186] As a result, the method of section V.D.1.b might require separate computations for determining luma and chroma positions even when the luma and chroma resolution is the same in some dimension and no phase shift is intended, just because the rounding will be performed slightly differently in the two cases. This is undesirable, so a different handling of chroma is suggested in this section for use with 4:2:2 and 4:4:4 sampling structures.

a. 4:2:2 Vertical and 4:4:4 Horizontal and Vertical Positions

[0187] For the vertical dimension of 4:2:2 video and for both vertical and horizontal dimensions of 4:4:4 video, there is no apparent need for the custom control of chroma phase. Therefore, whenever the chroma resolution is the same as the luma resolution in some dimension, the equations for the computation of chroma positions should be modified to result in computing the exact same positions for both luma and chroma samples whenever the chroma sampling format has the same resolution for luma and chroma in a particular dimension. One option is just to set the chroma position variables equal to the luma position variables, and another is to set up the chroma position equations so that they have the same result.

b. 4:2:2 Horizontal Positions

[0188] While there is no functional problem with allowing chroma phase adjustment horizontally for 4:2:2 video, if there is only one type of horizontal subsampling structure that is in use for 4:2:2, such as one that corresponds to the value -1 for scaledBaseChromaPhaseX or BaseChromaPhaseX in the equations of section V.D.1.b, it may be desirable to consider forcing these values to be used whenever the color sampling format is 4:2:2.

VI. Extensions and Alternatives

[0189] Techniques and tools described herein also can be applied to multi-resolution video coding using reference picture resampling as found, for example in Annex P of the ITU-T international standard Recommendation H.263.

[0190] Techniques and tools described herein also can be applied not only to the upsampling of picture sample arrays, but also to the upsampling of residual data signals or other signals. For example, techniques and tools described herein also can be applied to the upsampling of residual data signals for reduced resolution update coding as found, for example in Annex Q of the ITU-T international standard Recommendation H.263. As another example, techniques and tools described herein can also be applied to the upsampling of residual data signals for prediction of high-resolution residual signals from lower-resolution residual signals in a design for spatial scalable video coding. As a further example, techniques and tools described herein can also be applied to the upsampling of motion vector fields in a design for spatial scalable video coding. As a further example, techniques and tools described herein can also be applied to upsampling of graphics images, photographic still pictures, audio sample signals, etc.

[0191] Having described and illustrated the principles of my invention with reference to various described embodiments, it will be recognized that the described embodiments can be modified in arrangement and detail without departing from such principles. It should be understood that the programs, processes, or methods described herein are not related or limited to any particular type of computing environment, unless indicated otherwise. Various types of general purpose or specialized computing environments may be used with or perform operations in accordance with the teachings described herein. Elements of the described embodiments shown in software may be implemented in hardware and vice versa.

[0192] In view of the many possible embodiments to which the principles of my invention may be applied, I claim as my invention all such embodiments as may come within the scope of the following claims and equivalents thereto.

5 **Claims**

1. A computer implemented method comprising:
 performing resampling of image data according to a horizontal or vertical resampling scale factor, wherein the resampling comprises computation of a sample value at horizontal or vertical position i in a resampled array, and
 10 wherein the computation comprises:
 computing a derived horizontal or vertical sub-sample position x in a manner that is mathematically equivalent in result to the formula $x = (i * C + D) \gg S$, wherein C is derived by approximating a value equivalent to 2^{S+F} multiplied by an inverse of the horizontal or vertical resampling scale factor, and wherein F , C , D , and S are integer values.

15 2. The method of claim 1 wherein said resampling of image data is an upsampling of a video picture according to a horizontal upsampling scale factor and a vertical upsampling scale factor, wherein the upsampling comprises computation of an interpolated sample value at the horizontal position i and the vertical position j in an upsampled array, and wherein the computation comprises:

20 said computing the derived horizontal sub-sample position x in a manner that is mathematically equivalent in result to the formula $x = (i * C + D) \gg S$,
 wherein C is derived by approximating a value equivalent to 2^{S+F} multiplied by an inverse of the horizontal upsampling scale factor, and wherein F , C , D , and S are integer values;
 computing the derived vertical sub-sample position y in a manner that is mathematically equivalent in result to
 25 the formula $y = (j * C + D) \gg S$,
 wherein C is derived by approximating a value equivalent to 2^{S+F} multiplied by an inverse of the vertical up-sampling scale factor; and
 interpolating a sample value at the derived sub-sample position x , y .

30 3. The method of claim 2 wherein the computation further comprises:

selecting a horizontal resampling filter based on F least significant bits of the derived horizontal sub-sample position x ; and
 selecting lower resolution samples to be filtered based on the remaining more significant bits of the derived
 35 horizontal sub-sample position x ; and
 wherein interpolating a sample value at the derived sub-sample position x , y comprises:
 interpolating the sample value based on the selected lower resolution samples and using the selected horizontal resampling filter.

40 4. The method of claim 3 wherein a horizontal resampling filter applied for at least one value of the F least significant bits of the derived horizontal sub-sample position x is a finite impulse response filter with more than two non-zero filter tap values, and
 a horizontal resampling filter applied for all values other than 0 for the F least significant bits of the derived horizontal sub-sample position x is a finite impulse response filter with four non-zero filter tap values.

45 5. The method of claim 2 wherein the computation further comprises:

selecting a vertical resampling filter based on F least significant bits of the derived vertical sub-sample position
 y ; and
 50 selecting lower resolution samples to be filtered based on the remaining more significant bits of the derived vertical sub-sample position y ; and
 wherein interpolating a sample value at the derived sub-sample position x , y comprises:
 interpolating the sample value based on the selected lower resolution samples and using the selected vertical resampling filter.

55 6. The method of claim 5 wherein a vertical resampling filter applied for at least one value of the F least significant bits of the derived vertical sub-sample position y is a finite impulse response filter with more than two non-zero filter tap values, and

a vertical resampling filter applied for all values other than 0 for the F least significant bits of the derived vertical sub-sample position y is a finite impulse response filter with four non-zero filter tap values.

- 5 7. The method of claim 2 wherein the upsampling is performed using one or more Mitchell-Netravalli resampling filters or one or more Catmull-Rom resampling filters.
8. The method of claim 2 wherein at least one of the vertical or horizontal values of F , C , D , or S differs based at least in part on whether the sample value is a chroma sample value or a luma sample value.
- 10 9. The method of claim 2 wherein a manner that is mathematically equivalent in result to the formula $x = (i * C + D) \gg S$ comprises an implementation of the formula $x = ((i * C + D) \gg S) + E$, where E is an offset.
- 15 10. The method of claim 2 wherein the upsampling is performed using one or more resampling filters having filter tap values controlled by a bandwidth control parameter.
11. The method of claim 2 wherein the upsampling is performed in a layered spatially-scalable video encoding or decoding process.
- 20 12. The method of claim 2 wherein the upsampling is performed for reference picture resampling.
13. The method of claim 2 wherein the approximating comprises rounding and/or the inverse is an approximate inverse.
- 25 14. The method of claim 2 wherein at least one of the F , C , D , and S integer values are different for the horizontal computing than for the vertical computing, in particular F is equal to 4 and the value of S is equal to 12.
- 30 15. The method of claim 1, wherein said resampling of image data is an upsampling of a video picture according to an upsampling scale factor, wherein the upsampling comprises computation of an interpolated sample value at the horizontal position i and the vertical position j in an upsampled array, and wherein the computation comprises:
- 35 said computing the derived horizontal sub-sample position x in a manner mathematically equivalent in result to the formula $x = ((2^J * i + Q) * C + D) \gg S$, wherein C is derived by approximating a value equivalent to 2^{S+F} multiplied by an inverse of the upsampling scale factor, and wherein F , C , D , S , J and Q are integers; computing the derived vertical sub-sample position y in a manner that is mathematically equivalent in result to the formula $y = ((2^J * j + Q) * C + D) \gg S$; and
- interpolating a sample value at the derived sub-sample position x , y .
16. A computer-readable medium storing computer-executable instructions for causing a processor, when programmed thereby, to perform the method of any one of claims 1-15.
- 40 17. A computer system configured to perform the method of any one of claims 1-15.

Patentansprüche

- 45 1. Computerimplementiertes Verfahren umfassend:
Durchführen der Neuberechnung von Bilddaten entsprechend einem horizontalen oder vertikalen Neuberechnungs-Skalierungsfaktor, wobei die Neuberechnung die Berechnung eines Abtastwerts an einer horizontalen oder vertikalen Position i in einem Neuberechneten Feld umfasst, und wobei die Berechnung umfasst:
Berechnen einer abgeleiteten horizontalen oder vertikalen Unterabtastposition x auf eine Weise, die mathematisch gleichwertig im Ergebnis mit der Formel $x = (i * C + D) \gg S$ ist, wobei C durch Nähern eines Werts gleichwertig mit 2^{S+F} multipliziert mit einem Umkehrwert des horizontalen oder vertikalen Neuberechnungs-Skalierungsfaktors abgeleitet wird, und wobei F , C , D und S Ganzzahlenwerte sind.
- 50
- 55 2. Verfahren nach Anspruch 1, wobei die Neuberechnung von Bilddaten eine Aufwärtstastung eines Videobilds entsprechend einem horizontalen Aufwärtstastungs-Skalierungsfaktors und eines vertikalen Aufwärtstastungs-Skalierungsfaktors ist, wobei die Aufwärtstastung die Berechnung eines interpolierten Abtastwerts an der horizontalen Position i und der vertikalen Position j in einem aufwärtsgetasteten Feld ist, und wobei die Berechnung umfasst:

das Berechnen der abgeleiteten horizontalen Unterabtastposition x auf eine Weise, die mathematisch gleichwertig im Ergebnis mit der Formel $x = (i * C + D) \gg S$ ist, wobei C durch Nähern eines Wertes gleichwertig mit 2^{S+F} multipliziert mit einem Umkehrwert des horizontalen Aufwärtstastungs-Skalierungsfaktors abgeleitet wird, und wobei F , C , D und S Ganzzahlenwerte sind.

Berechnen der abgeleiteten vertikalen Unterabtastposition y auf eine Weise, die mathematisch gleichwertig im Ergebnis mit der Formel $y = (j * C + D) \gg S$ ist, wobei C durch Nähern eines Wertes gleichwertig mit 2^{S+F} multipliziert mit einem Umkehrwert des vertikalen Aufwärtstastungs-Skalierungsfaktors abgeleitet wird; und Interpolieren eines Abtastwerts an der abgeleiteten Unterabtastposition x , y .

3. Verfahren nach Anspruch 2, wobei die Berechnung ferner umfasst:

Auswählen eines horizontalen Neuberechnungsfilters auf der Basis von F niederwertigsten Bits der abgeleiteten horizontalen Unterabtastposition x ; und

Auswählen von niedriger aufgelösten Abtastungen zum Filtern auf der Basis der restlichen höherwertigen Bits der abgeleiteten horizontalen Unterabtastposition x ; und

wobei das Interpolieren eines Abtastwerts an der abgeleiteten Unterabtastposition x , y umfasst:

Interpolieren des Abtastwerts auf der Basis der ausgewählten niedriger aufgelösten Abtastungen und Verwenden des ausgewählten horizontalen Neuberechnungsfilters.

4. Verfahren nach Anspruch 3, wobei ein für wenigstens einen Wert der F niedrigstwertigen Bits der abgeleiteten horizontalen Unterabtastposition x angewendetes horizontales Neuberechnungsfilter ein Filter mit endlicher Impulsantwort mit mehr als zwei Nicht-Null-Filterabzweigwerten ist, und ein für alle Werte ungleich 0 für die F niedrigstwertigen Bits der abgeleiteten horizontalen Unterabtastposition x angewendetes horizontales Neuberechnungsfilter ein Filter mit endlicher Impulsantwort mit vier Nicht-Null-Filterabzweigwerten ist.

5. Verfahren nach Anspruch 2, wobei die Berechnung ferner umfasst:

Auswählen eines vertikalen Neuberechnungsfilters auf der Basis von F niedrigstwertigen Bits der abgeleiteten vertikalen Unterabtastposition y ; und

Auswählen von niedriger aufgelösten Abtastungen zum Filtern auf der Basis der restlichen höherwertigen Bits der abgeleiteten vertikalen Unterabtastposition y ; und

wobei das Interpolieren eines Abtastwerts an der abgeleiteten Unterabtastposition x , y umfasst:

Interpolieren des Abtastwerts auf der Basis der ausgewählten niedriger aufgelösten Abtastungen und Verwenden des ausgewählten vertikalen Neuberechnungsfilters.

6. Verfahren nach Anspruch 5, wobei ein für wenigstens einen Wert der F niedrigstwertigen Bits der abgeleiteten vertikalen Unterabtastposition y angewendetes vertikales Neuberechnungsfilter ein Filter mit endlicher Impulsantwort mit mehr als zwei Nicht-Null-Filterabzweigwerten ist, und ein für alle Werte ungleich 0 für die F niedrigstwertigen Bits der abgeleiteten vertikalen Unterabtastposition y angewendetes vertikales Neuberechnungsfilter ein Filter mit endlicher Impulsantwort mit vier Nicht-Null-Filterabzweigwerten ist.

7. Verfahren nach Anspruch 2, wobei die Aufwärtstastung unter Verwendung von einem oder mehreren Mitchell-Netravalli-Neuberechnungsfiltern oder einem oder mehreren Catmull-Rom-Neuberechnungsfiltern durchgeführt wird.

8. Verfahren nach Anspruch 2, wobei sich wenigstens einer der vertikalen oder horizontalen Werte von F , C , D oder S auf der Basis von wenigstens teilweise, ob der Abtastwert ein Farbsättigungs-Abtastwert oder ein Luminanz-Abtastwert ist, unterscheidet.

9. Verfahren nach Anspruch 2, wobei eine Weise, die mathematisch gleichwertig im Ergebnis mit der Formel $x = (i * C + D) \gg S$ ist, eine Implementierung der Formel $x = ((i * C + D) \gg S) + E$ umfasst, wobei E ein Versatz ist.

10. Verfahren nach Anspruch 2, wobei die Aufwärtstastung unter Verwendung von einem oder mehreren Neuberechnungsfiltern, deren Filterabzweigungswerte von einem Bandbreiten-Steuerparameter gesteuert werden.

11. Verfahren nach Anspruch 2, wobei die Aufwärtstastung in einem geschichteten räumlich skalierbaren Videover-

schlüsselungs- oder Videoentschlüsselungsprozess durchgeführt wird.

12. Verfahren nach Anspruch 2, wobei die Aufwärtstastung für eine Referenzbild-Neuberechnung durchgeführt wird.

5 13. Verfahren nach Anspruch 2, wobei das Nähern ein Runden umfasst und/oder der Umkehrwert ein Näherungsumkehrwert ist.

14. Verfahren nach Anspruch 2, wobei sich wenigstens einer der Ganzzahlwerte F , C , D und S für die horizontale Berechnung von dem für die vertikale Berechnung unterscheidet, wobei insbesondere F gleich 4 ist und der Wert von S gleich 12 ist.

15. Verfahren nach Anspruch 1, wobei die Neuberechnung von Bilddaten eine Aufwärtstastung eines Videobildes entsprechend einem Aufwärtstastungs-Skalierungsfaktore ist, wobei die Aufwärtstastung die Berechnung eines interpolierten Abtastwerts an der horizontalen Position i und der vertikalen Position j in einem aufwärtsgetasteten Feld umfasst, und wobei die Berechnung umfasst:

die Berechnung der abgeleiteten horizontalen Unterabtastposition x auf eine Weise mathematisch gleichwertig im Ergebnis mit der Formel $x = ((2^{J*}i+Q)*C+D) >> S$, wobei C durch Nähern eines Werts gleichwertig mit 2^{S+F} multipliziert mit einem Umkehrwert des Aufwärtstastungs-Skalierungsfaktors abgeleitet wird, und wobei F , C , D , S , J und Q Ganzzahlen sind;

Berechnen der abgeleiteten vertikalen Unterabtastposition y auf eine Weise, die mathematisch gleichwertig im Ergebnis mit der Formel $y = ((2^{J*}j+Q)*C+D) >> S$ ist; und

Interpolieren eines Abtastwerts an der abgeleiteten Unterabtastposition x , y .

25 16. Computerlesbares Medium zum Speichern von computerausführbaren Anweisungen zum Veranlassen eines Prozessors, wenn dadurch programmiert, zum Ausführen des Verfahrens nach einem der Ansprüche 1-15.

17. Zum Ausführen des Verfahrens nach einem der Ansprüche 1-15 ausgebildetes Computersystem.

Revendications

1. Procédé mis en oeuvre par ordinateur, consistant à :

procéder à un rééchantillonnage de données d'image conformément à un facteur d'échelle de rééchantillonnage horizontal ou vertical, dans lequel le rééchantillonnage comprend le calcul d'une valeur d'échantillon au niveau d'une position horizontale ou verticale i dans un tableau rééchantillonné, et dans lequel le calcul comprend :

le calcul d'une position de sous-échantillon horizontale ou verticale déduite x selon une méthode dont le résultat est mathématiquement équivalent à la formule $x = (i * C + D) >> s$, dans lequel C est obtenu par approximation d'une valeur équivalente à 2^{S+F} multipliée par un inverse du facteur d'échelle de rééchantillonnage horizontal ou vertical, et dans lequel F , C , D et S sont des valeurs entières.

2. Procédé selon la revendication 1, dans lequel ledit rééchantillonnage de données d'image est un suréchantillonnage d'une image vidéo conformément à un facteur d'échelle de suréchantillonnage horizontal et à un facteur d'échelle de suréchantillonnage vertical, dans lequel le suréchantillonnage comprend le calcul d'une valeur d'échantillon interpolée au niveau de la position horizontale i et de la position verticale j dans un tableau suréchantillonné, et dans lequel le calcul comprend :

ledit calcul de la position de sous-échantillon horizontale déduite x selon une méthode dont le résultat est mathématiquement équivalent à la formule $x = (i * C + D) >> S$, dans lequel C est obtenu par approximation d'une valeur équivalente à 2^{S+F} multipliée par un inverse du facteur d'échelle de suréchantillonnage horizontal, et dans lequel F , C , D et S sont des valeurs entières ;

le calcul de la position de sous-échantillon verticale déduite y selon une méthode dont le résultat est mathématiquement équivalent à la formule $y = (j * C + D) >> S$, dans lequel C est obtenu par approximation d'une valeur équivalente à 2^{S+F} multipliée par un inverse du facteur d'échelle de suréchantillonnage vertical ; et l'interpolation d'une valeur d'échantillon au niveau de la position de sous-échantillon déduite x , y .

3. Procédé selon la revendication 2, dans lequel le calcul comprend, en outre :

EP 1 985 120 B1

- la sélection d'un filtre de rééchantillonnage horizontal sur la base des F éléments binaires les moins significatifs de la position de sous-échantillon horizontale déduite x ; et
la sélection d'échantillons de résolution inférieure à filtrer sur la base des éléments binaires plus significatifs restants de la position de sous-échantillon horizontale déduite x ; et
5 dans lequel l'interpolation d'une valeur d'échantillon au niveau de la position de sous-échantillon déduite x, y comprend :
l'interpolation de la valeur d'échantillon sur la base des échantillons de résolution inférieure sélectionnés et l'utilisation du filtre de rééchantillonnage horizontal sélectionné.
- 10 **4.** Procédé selon la revendication 3, dans lequel
un filtre de rééchantillonnage horizontal appliqué pour au moins une valeur des F éléments binaires les moins significatifs de la position de sous-échantillon horizontale déduite x est un filtre à réponse impulsionnelle finie ayant plus de deux valeurs de prise de filtre non nulles, et
un filtre de rééchantillonnage horizontal appliqué pour toutes les valeurs différentes de 0 pour les F éléments binaires
15 les moins significatifs de la position de sous-échantillon horizontal déduite x est un filtre à réponse impulsionnelle finie ayant quatre valeurs de prise de filtre non nulles.
- 5.** Procédé selon la revendication 2, dans lequel le calcul comprend en outre :
- 20 la sélection d'un filtre de rééchantillonnage vertical sur la base des F éléments binaires les moins significatifs de la position de sous-échantillon verticale y ; et
la sélection d'échantillons de résolution inférieure à filtrer sur la base des éléments binaires plus significatifs restants de la position de sous-échantillon verticale déduite y ; et
dans lequel l'interpolation d'une valeur d'échantillon au niveau de la position de sous-échantillon déduite x, y
25 comprend :
l'interpolation de la valeur d'échantillon sur la base des échantillons de résolution inférieure sélectionnés et l'utilisation du filtre de rééchantillonnage vertical sélectionné.
- 6.** Procédé selon la revendication 5, dans lequel un filtre de rééchantillonnage vertical appliqué pour au moins une
30 valeur des F éléments binaires les moins significatifs de la position de sous-échantillon verticale déduite y est un filtre à réponse impulsionnelle finie ayant plus de deux valeurs de prise de filtre non nulles, et
un filtre de rééchantillonnage vertical appliqué pour toutes les valeurs différentes de 0 pour les F éléments binaires les moins significatifs de la position de sous-échantillon verticale déduite y est un filtre à réponse impulsionnelle finie ayant quatre valeurs de prise de filtre non nulles.
- 35 **7.** Procédé selon la revendication 2, dans lequel le suréchantillonnage est réalisé au moyen d'un ou de plusieurs filtres de rééchantillonnage de Mitchell-Netravali ou d'un ou de plusieurs filtres de rééchantillonnage de Catmull-Rom.
- 8.** Procédé selon la revendication 2, dans lequel au moins une des valeurs verticale ou horizontale de F, C, D ou S
40 diffère en fonction, au moins en partie, du fait que la valeur d'échantillon est une valeur d'échantillon chroma ou une valeur d'échantillon luma.
- 9.** Procédé selon la revendication 2, dans lequel une méthode dont le résultat est mathématiquement équivalent à la
45 formule $x = (i * C + D) \gg S$ comprend une mise en oeuvre de la formule $x = ((i * C + D) \gg S) + E$, où E est un décalage.
- 10.** Procédé selon la revendication 2, dans lequel le suréchantillonnage est réalisé au moyen d'un ou de plusieurs filtres de rééchantillonnage ayant des valeurs de prise de filtre contrôlées par un paramètre de contrôle de bande passante.
- 11.** Procédé selon la revendication 2, dans lequel le suréchantillonnage est réalisé dans un processus de codage ou
50 décodage vidéo spatialement échelonné en couches.
- 12.** Procédé selon la revendication 2, dans lequel le suréchantillonnage est réalisé pour un rééchantillonnage d'image de référence.
- 55 **13.** Procédé selon la revendication 2, dans lequel l'approximation comprend un arrondissement et/ou l'inverse est un inverse approximatif.
- 14.** Procédé selon la revendication 2, dans lequel au moins une des valeurs entières F, C, D et S est différente pour le

EP 1 985 120 B1

calcul horizontal de ce qu'elle est pour le calcul vertical, en particulier F est égale à 4 et la valeur de S est égale à 12.

- 5 15. Procédé selon la revendication 1, dans lequel ledit rééchantillonnage de données d'image est un suréchantillonnage d'une image vidéo conformément à un facteur d'échelle de suréchantillonnage, dans lequel le suréchantillonnage comprend le calcul d'une valeur d'échantillon interpolée au niveau de la position horizontale i et de la position verticale j dans un tableau suréchantillonné, et dans lequel le calcul comprend :

10 ledit calcul de la position de sous-échantillon horizontale déduite x selon une méthode dont le résultat est mathématiquement équivalent à la formule $x = ((2^J * i + Q) * C + D) \gg S$, dans lequel C est obtenu par approximation d'une valeur équivalente à 2^{S+F} multipliée par un inverse du facteur d'échelle de suréchantillonnage, et dans lequel F , C , D , S , J et Q sont des entiers ;

15 le calcul de la position de sous-échantillon verticale déduite y selon une méthode dont le résultat est mathématiquement équivalent à la formule $y = ((2^J * j + Q) * C + D) \gg S$; et
l'interpolation d'une valeur d'échantillon au niveau de la position de sous-échantillon déduite x , y .

- 20 16. Support lisible par ordinateur sur lequel sont stockées des instructions exécutables par ordinateur destinées à faire exécuter par un processeur, lorsque ce dernier est programmé par ces instructions, le procédé selon l'une quelconque des revendications 1 à 15.

- 25 17. Système informatique configuré pour exécuter le procédé selon l'une quelconque des revendications 1-15.

Figure 1

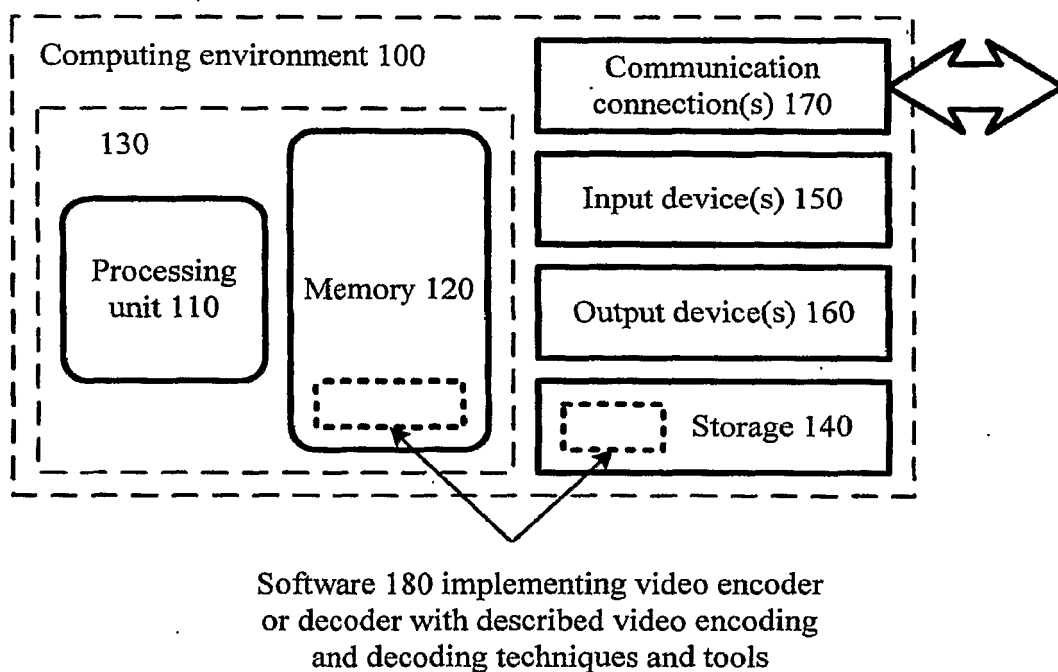

Figure 2

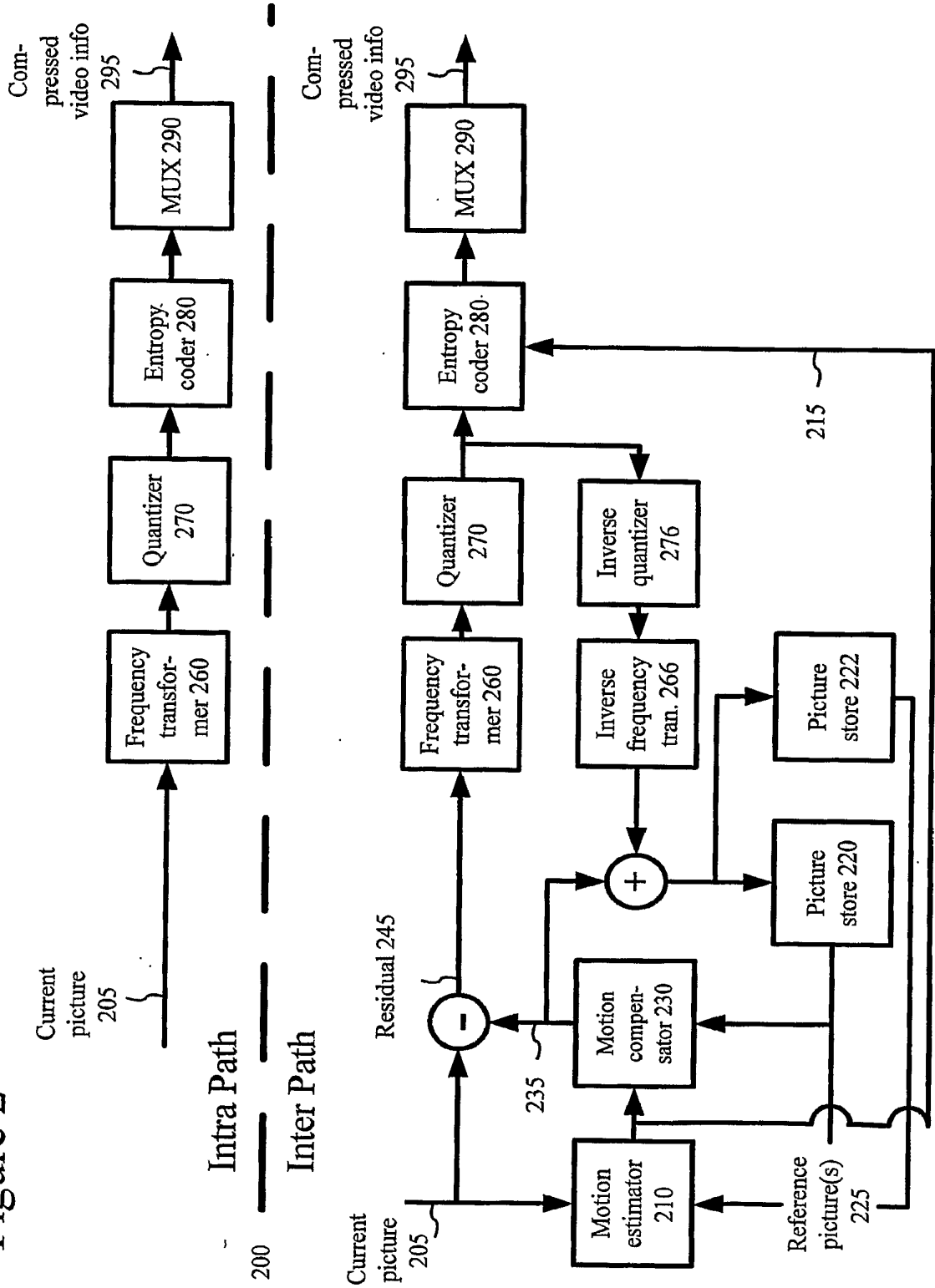

Figure 3

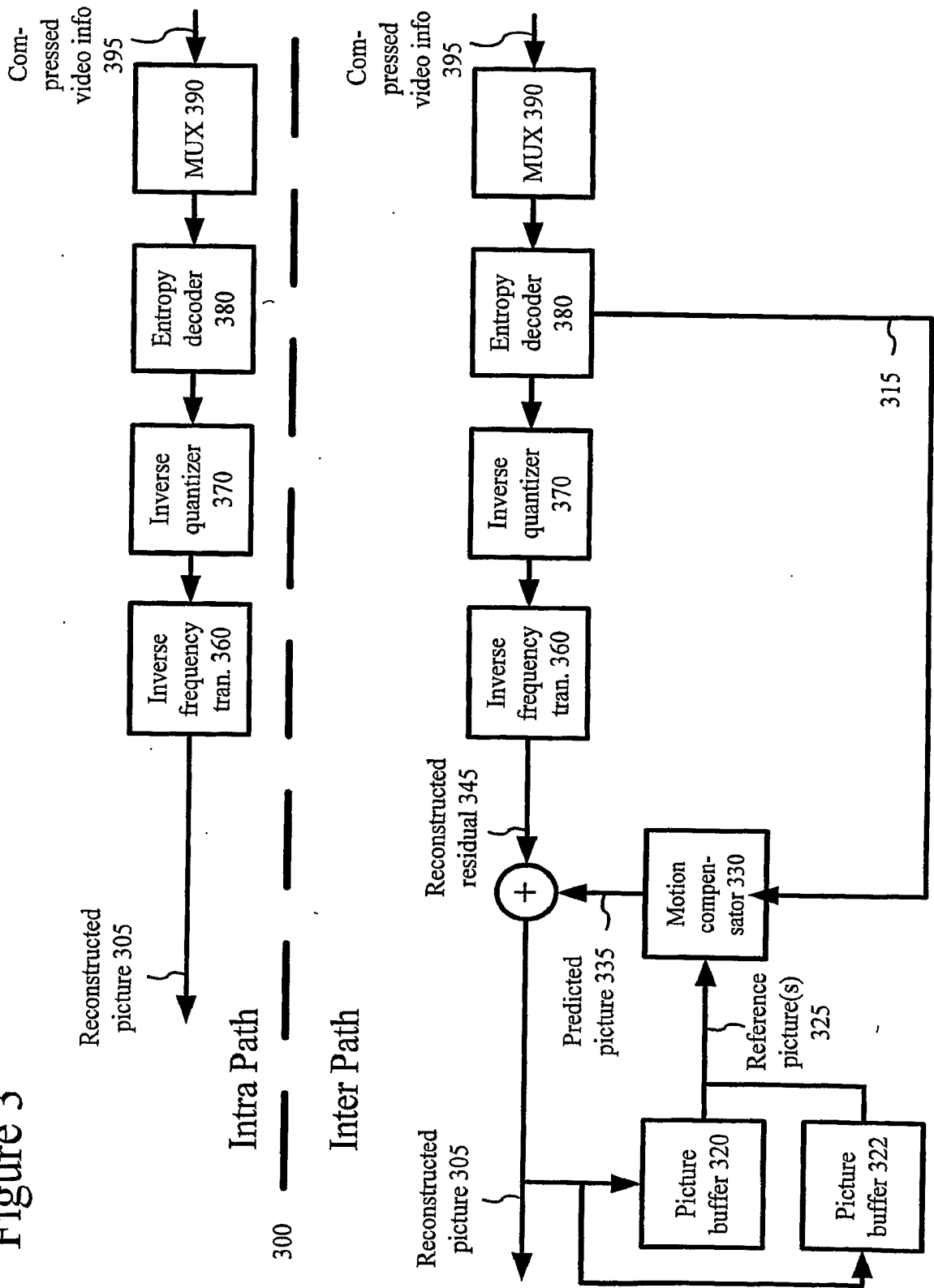

Figure 4

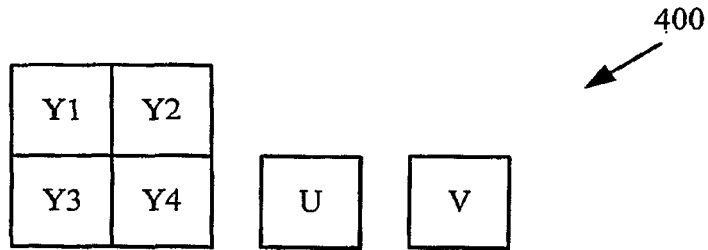

Figure 5A

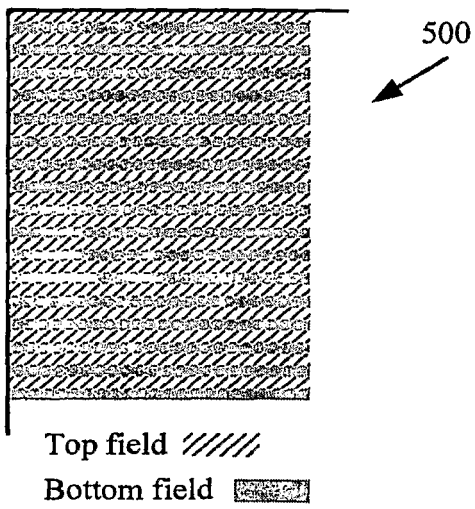

Figure 5B

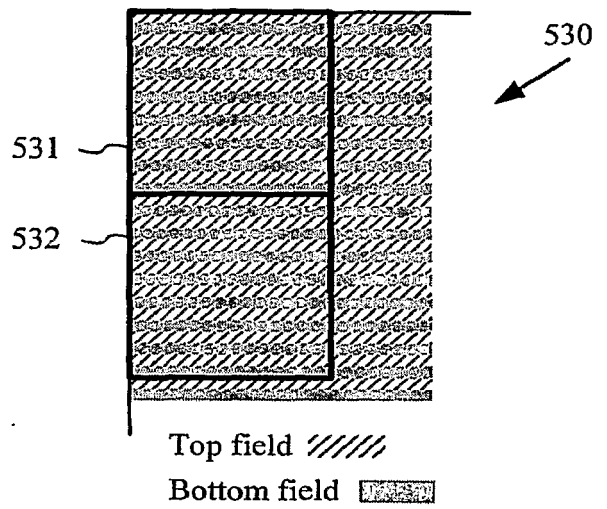

Figure 5C

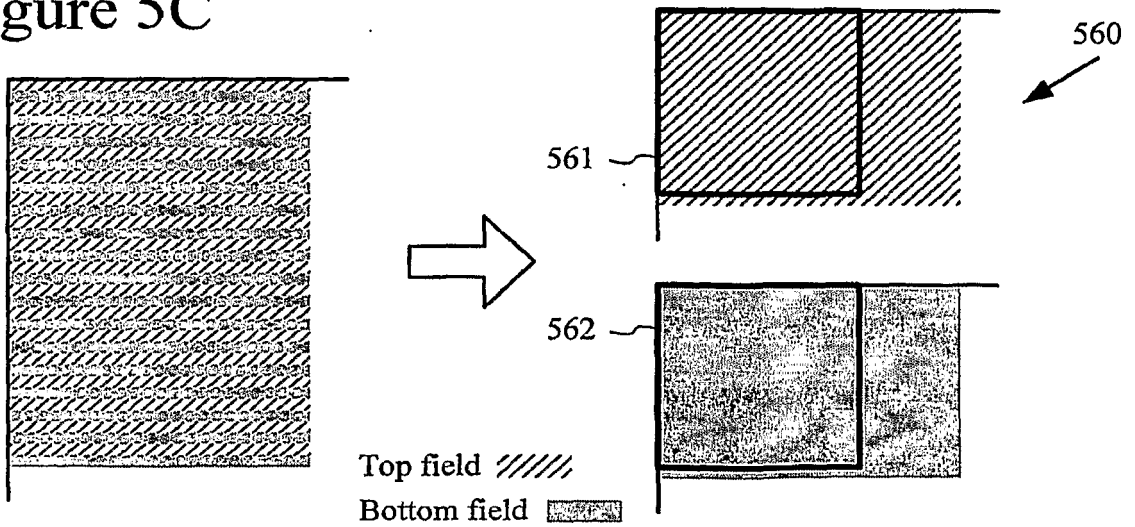
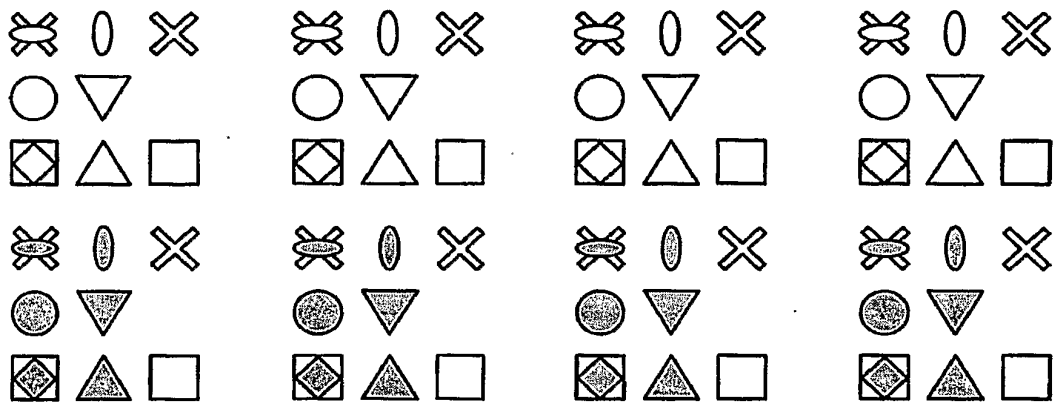









Figure 5D



-  : Luma sample, top field
-  : Chroma sample, top field, Type 0
-  : Chroma sample, top field, Type 1
-  : Chroma sample, top field, Type 2
-  : Chroma sample, top field, Type 3
-  : Chroma sample, top field, Type 4
-  : Chroma sample, top field, Type 5







-  : Luma sample, bottom field
-  : Chroma sample, bottom field, Type 0
-  : Chroma sample, bottom field, Type 1
-  : Chroma sample, bottom field, Type 2
-  : Chroma sample, bottom field, Type 3
-  : Chroma sample, bottom field, Type 4
-  : Chroma sample, bottom field, Type 5

Figure 6

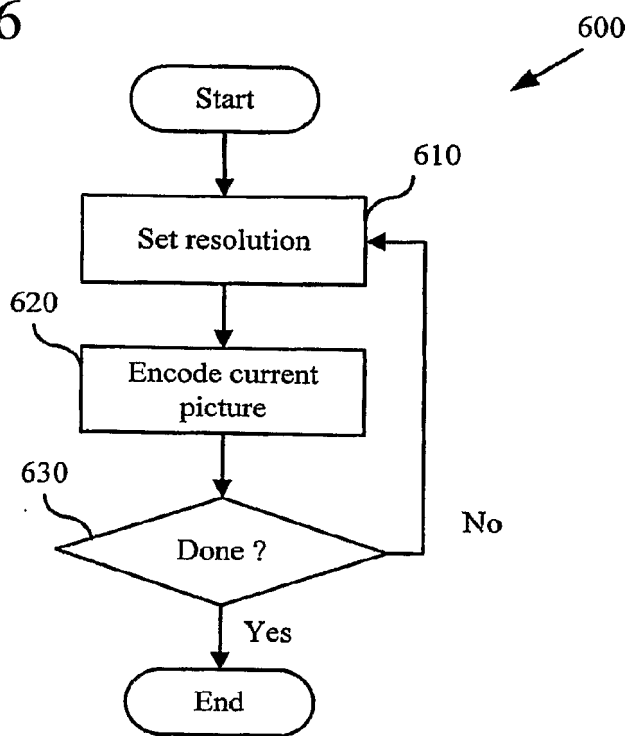

Figure 7

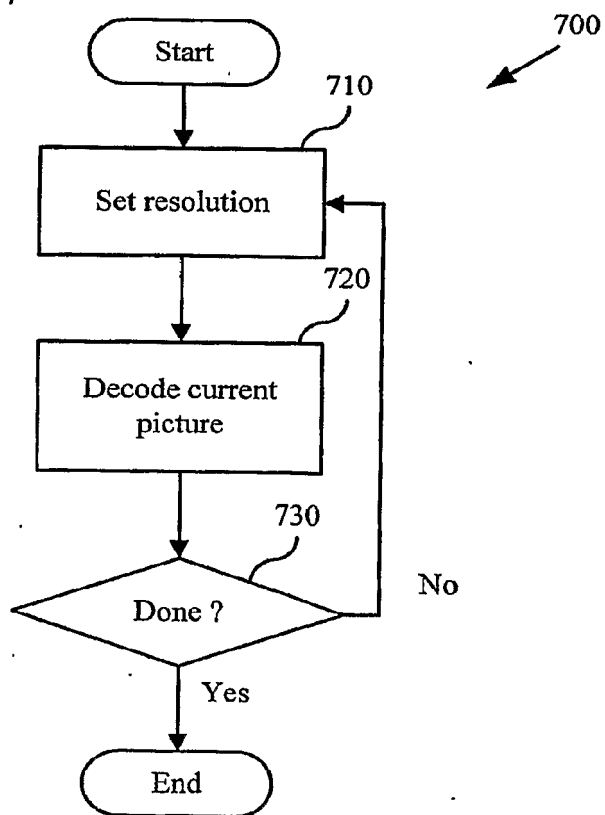

Figure 8

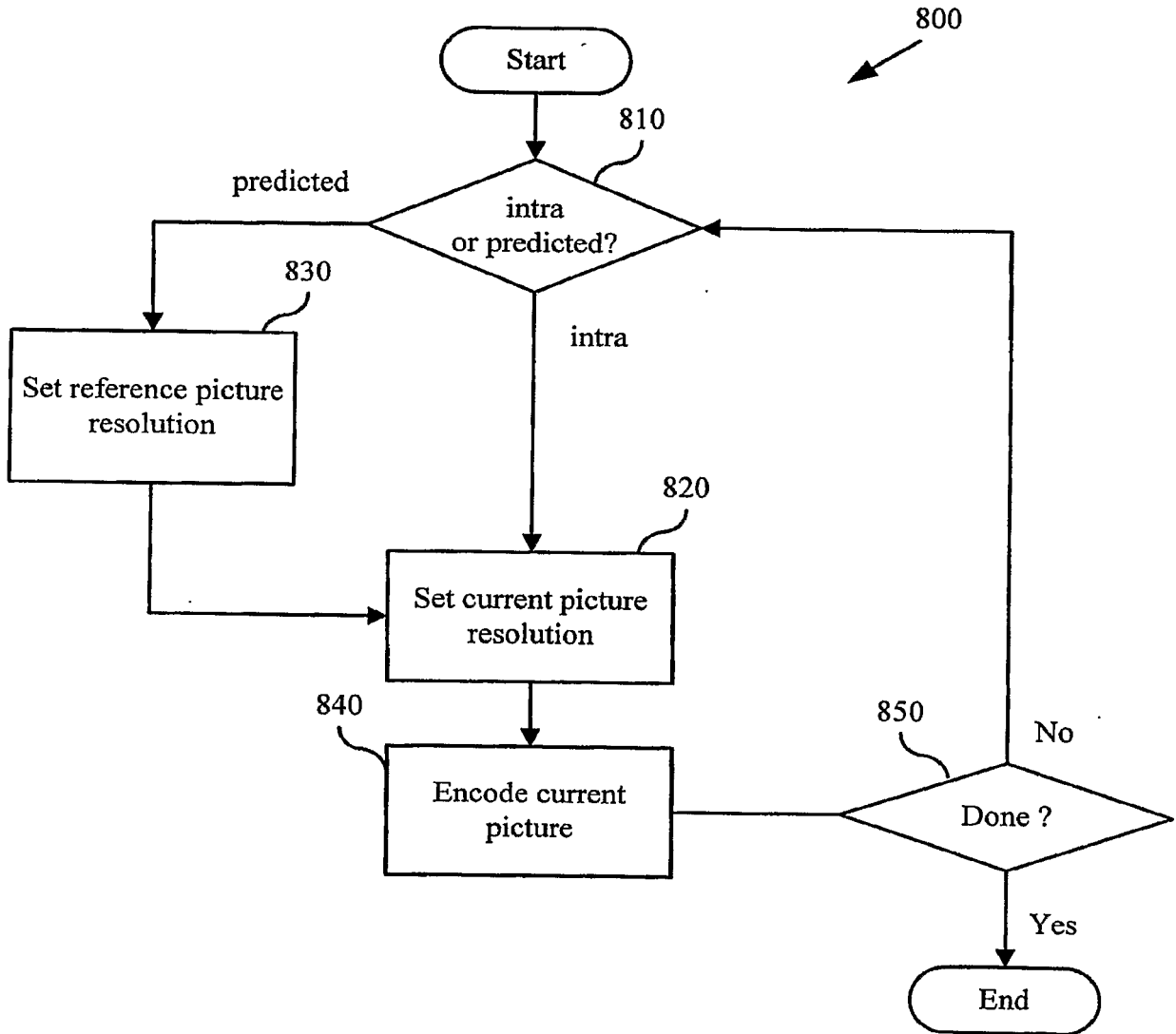

Figure 9

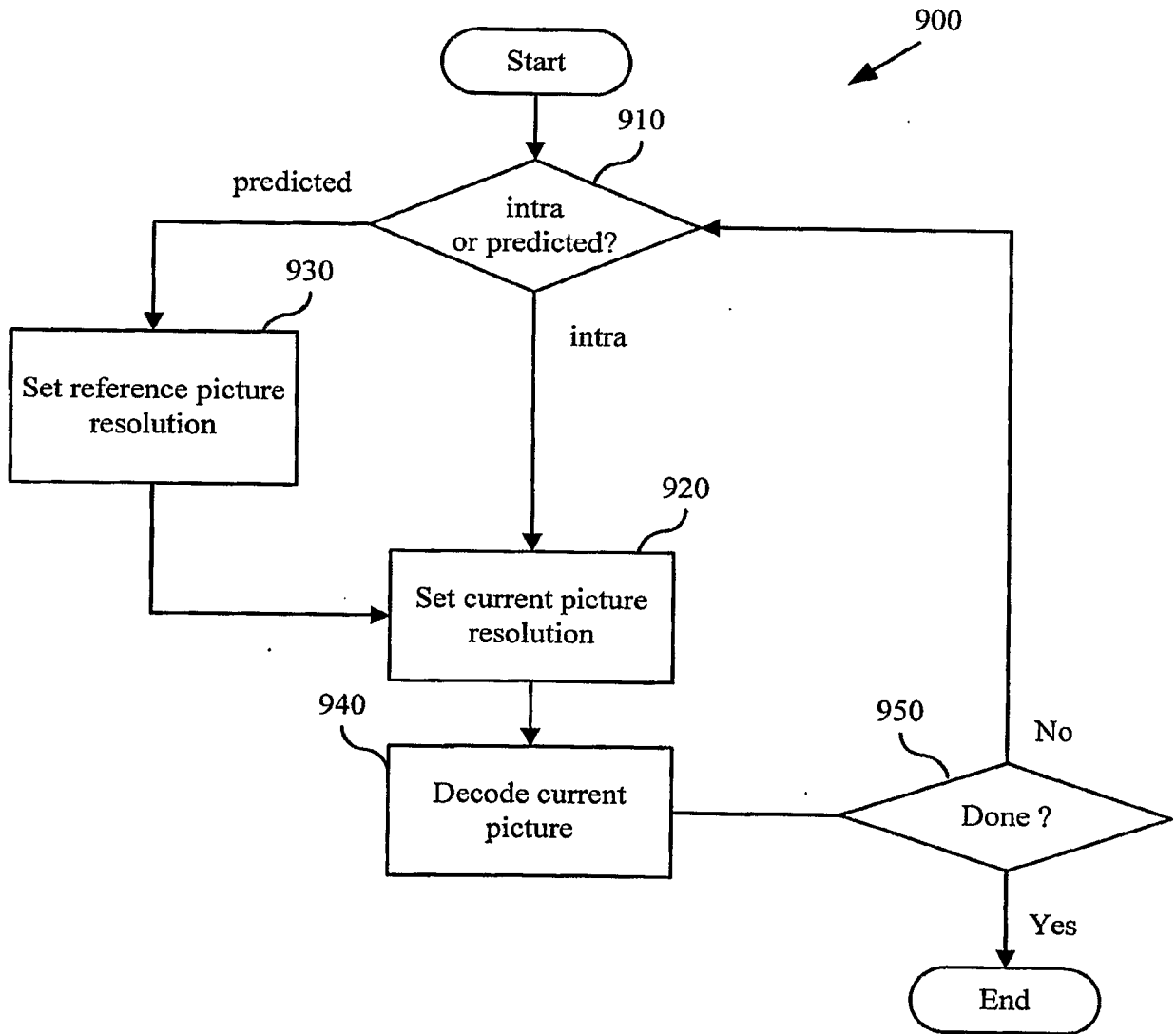

Figure 10

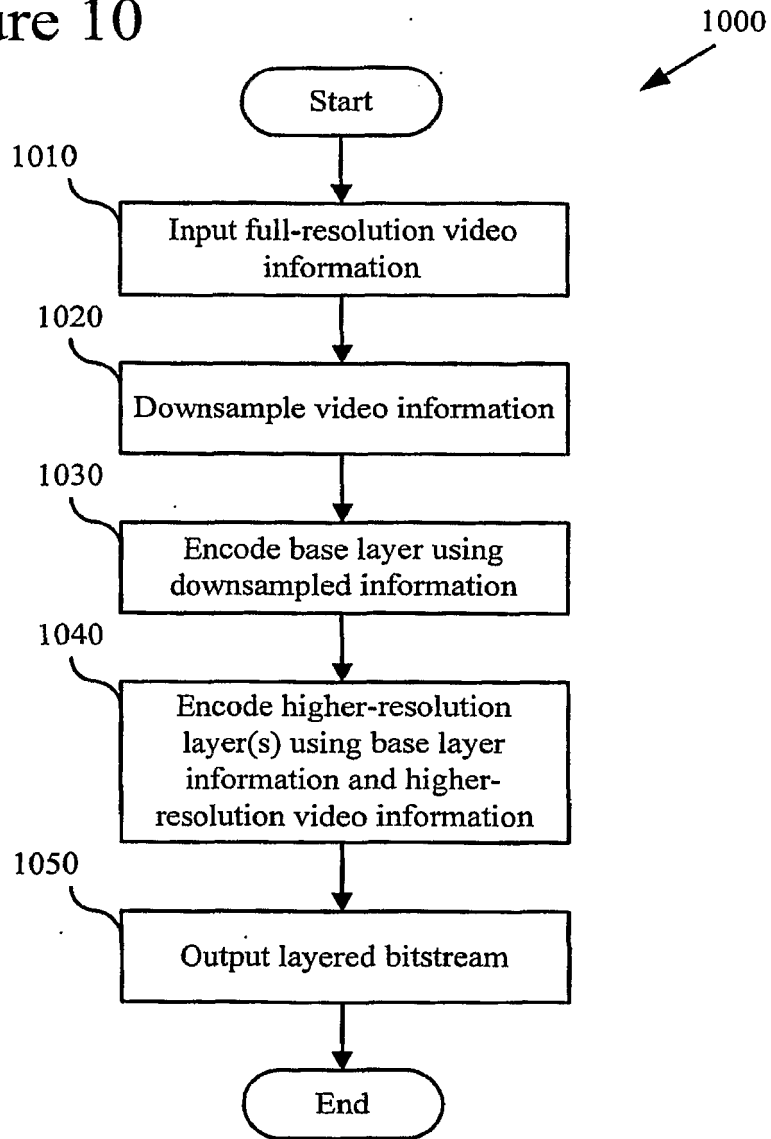

Figure 11

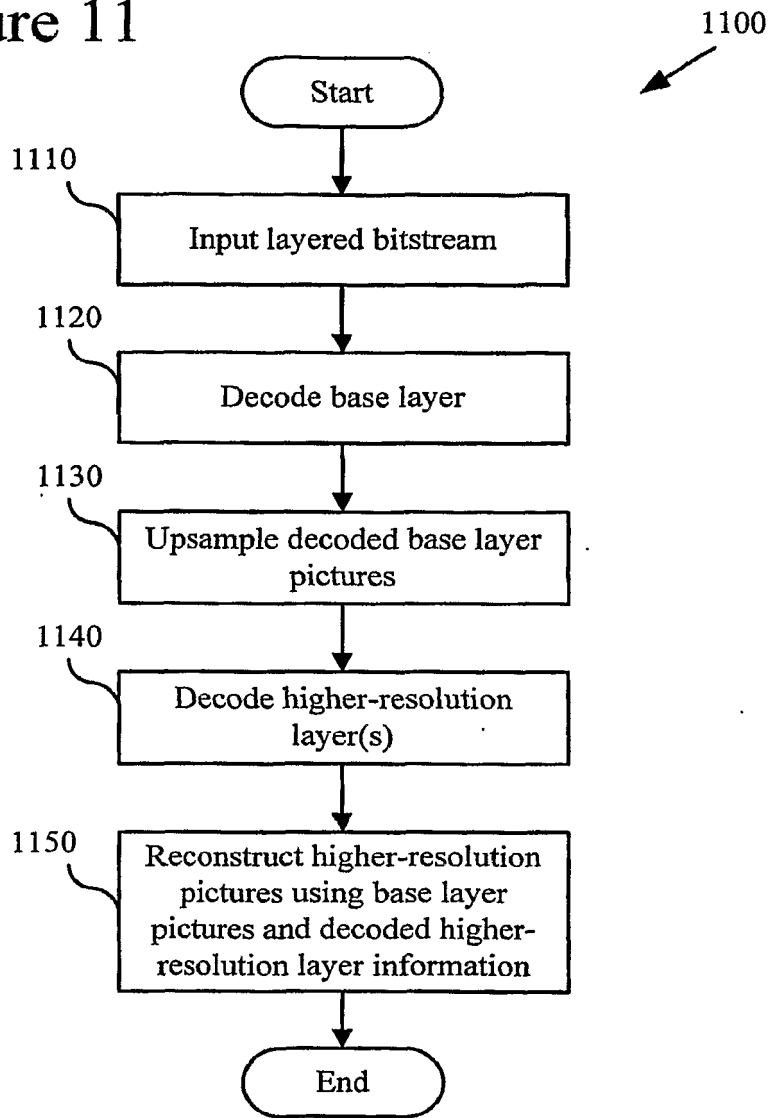

Figure 12

1200
↙

```

E = D >> S;
D' = D - (E << S);
for( i = 0; i < N; i++ ) {
    q = (p + i * 2') * C + D';
    t' = (q >> S) + E;
}

```

Figure 13

1300
↙

```

C' = C << J;
q = p * C + D;
/* First Stage */
w = q >> S;
E0 = w;
D0 = q - (w << S);
t0 = E0
for( i = 1; i < N0; i++ ) {
    q = i * C' + D0;
    t' = (q >> S) + E0;
}
/* Second Stage */
q = N0 * C' + D0;
w = q >> S;
E1 = E0 + w;
D1 = q - (w << S);
tN0 = E1;
for( i = 1; i < N - N0; i++ ) {
    q = i * C' + D1;
    tN0+i = (q >> S) + E1;
}

```

Figure 14

1400

```
C' = C << J;  
E = 0;  
  
q = p * C + D;  
w = q >> S;  
D' = q - (w << S);  
E += w;  
t0 = E;  
  
for( i = 1; i < N; i++ ) {  
    q = C' + D'  
    w = q >> S;  
    D' = q - (w << S);  
    E += w;  
    t'i = E;  
}
```

REFERENCES CITED IN THE DESCRIPTION

This list of references cited by the applicant is for the reader's convenience only. It does not form part of the European patent document. Even though great care has been taken in compiling the references, errors or omissions cannot be excluded and the EPO disclaims all liability in this regard.

Patent documents cited in the description

- US 6728317 B1 [0006]
- US 6510177 B [0078] [0079]