



US 20150150419A1

(19) **United States**

(12) **Patent Application Publication**
Littlehorn, SR.

(10) **Pub. No.: US 2015/0150419 A1**

(43) **Pub. Date: Jun. 4, 2015**

(54) **PORTABLE HAND WASHING STATION**

(52) **U.S. Cl.**

CPC *A47K 1/02* (2013.01)

(71) Applicant: **Michael J. Littlehorn, SR.**, Golden, CO (US)

(57) **ABSTRACT**

(72) Inventor: **Michael J. Littlehorn, SR.**, Golden, CO (US)

(21) Appl. No.: **14/559,909**

(22) Filed: **Dec. 3, 2014**

Related U.S. Application Data

(63) Continuation-in-part of application No. 13/209,666, filed on Aug. 15, 2011, now Pat. No. 8,925,124.

Publication Classification

(51) **Int. Cl.**
A47K 1/02 (2006.01)

A portable hand washing station is provided that has a carrying case with an interior hand washing compartment. A case front wall includes a door to permit hand access into the interior of the hand washing compartment. A lid is connected to the case so that the lid is capable of extending in an upright vertical position. A shelf is connected to the interior surface of the lid. A pair of liquid dispensing reservoirs is supported on the shelf. Each of the reservoirs includes a top wall with a mouth opening, a bottom wall with a drain opening, and a touch operated flow valve connected to the bottom wall in liquid communication to the bottom wall. The flow valves extend in axial alignment each one of the valve openings so that a cleaning or rinsing solution is dispensed into the compartment when the flow valves are deflected by hand.

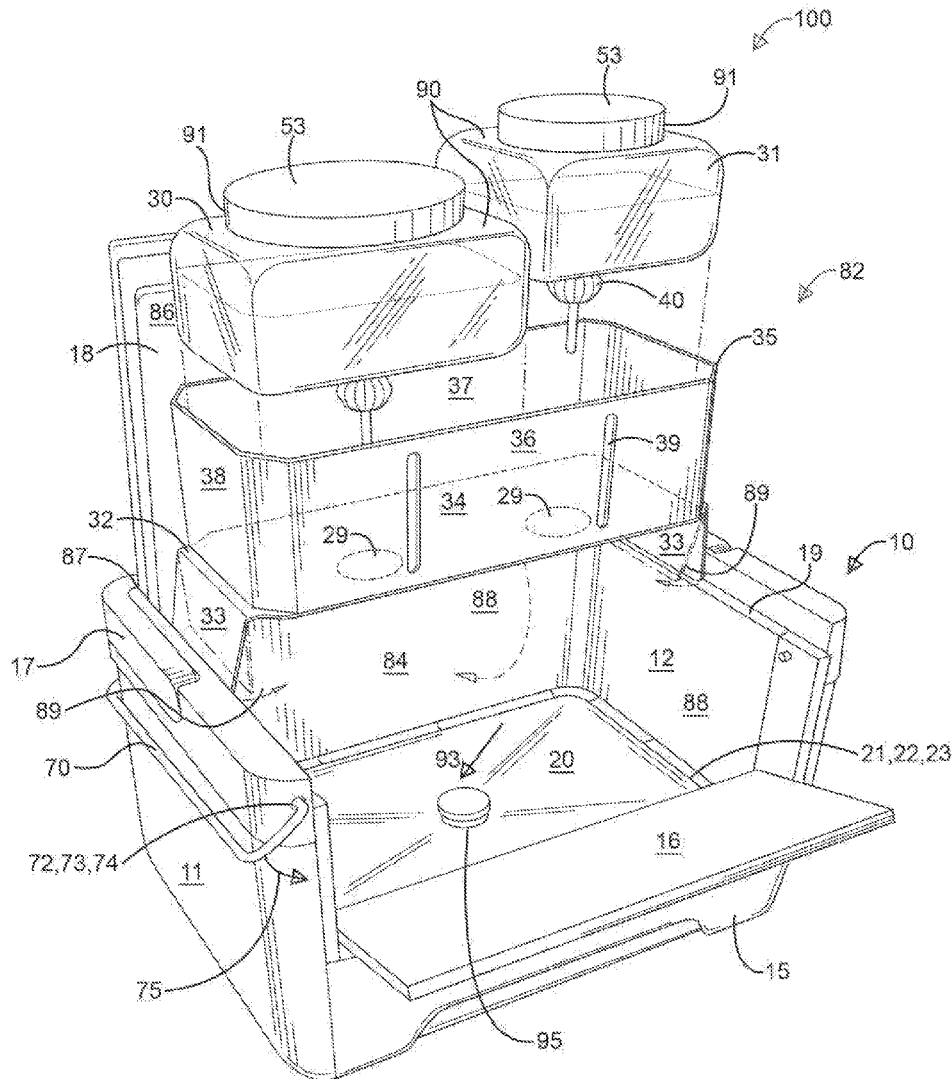

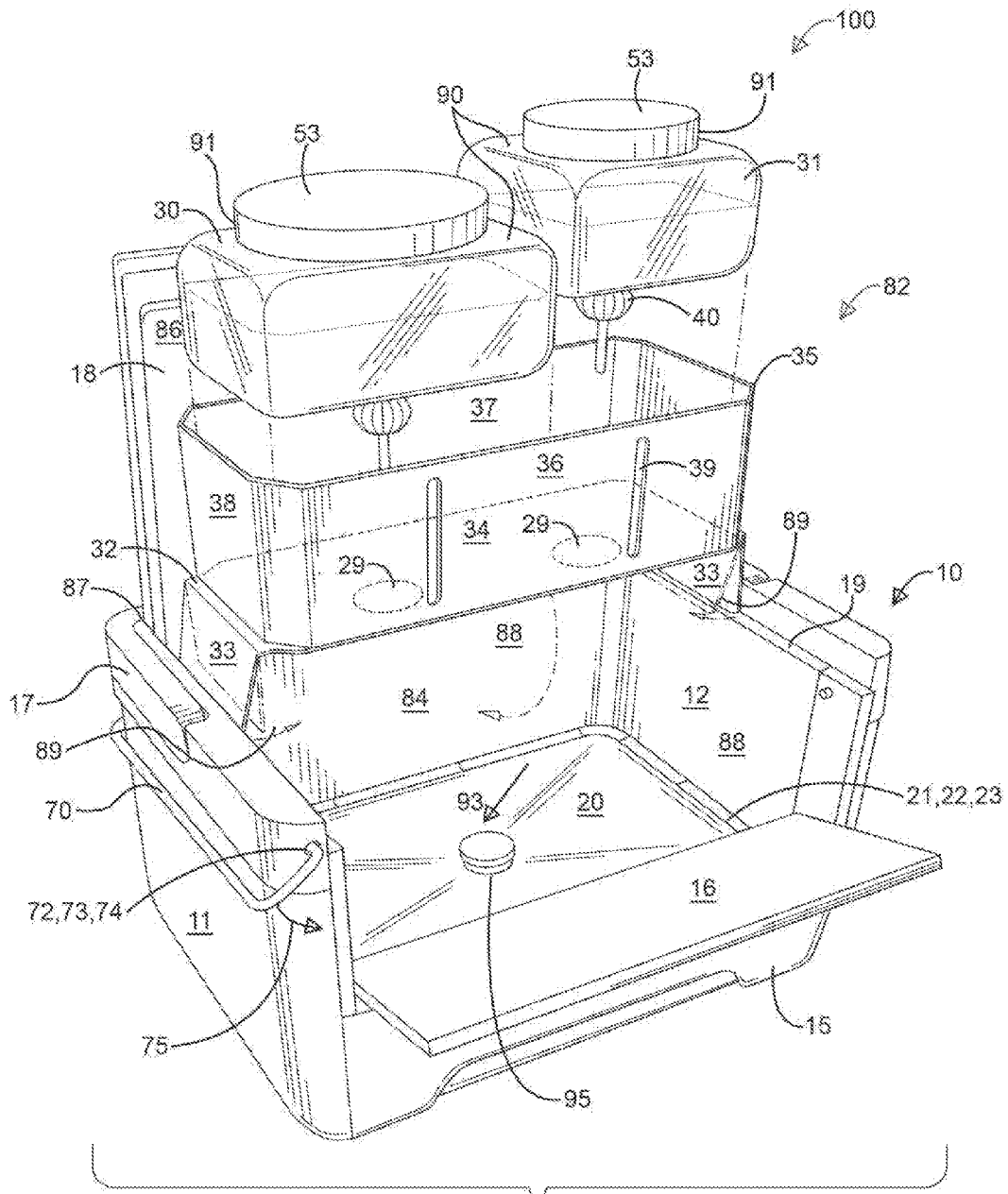
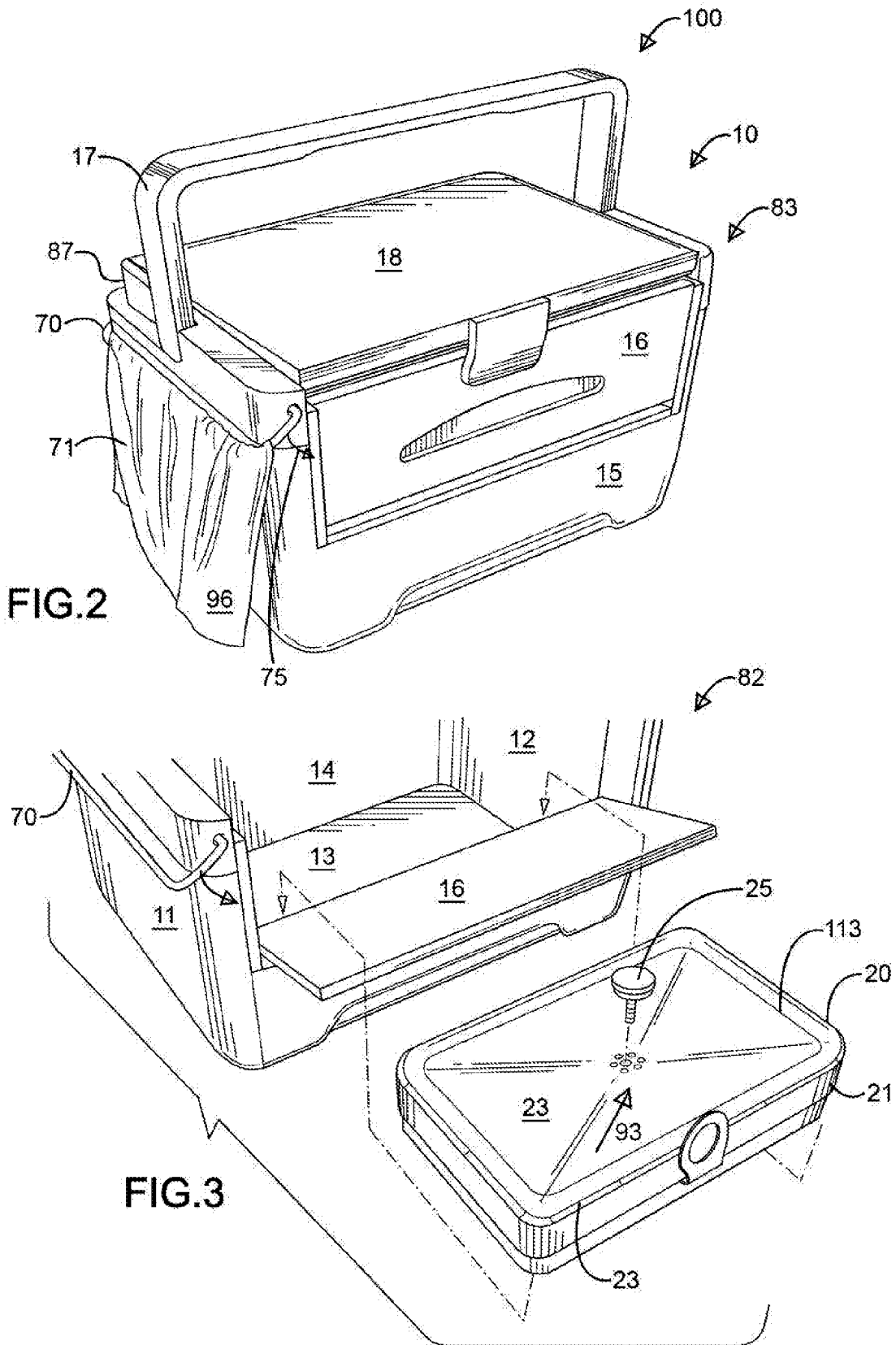
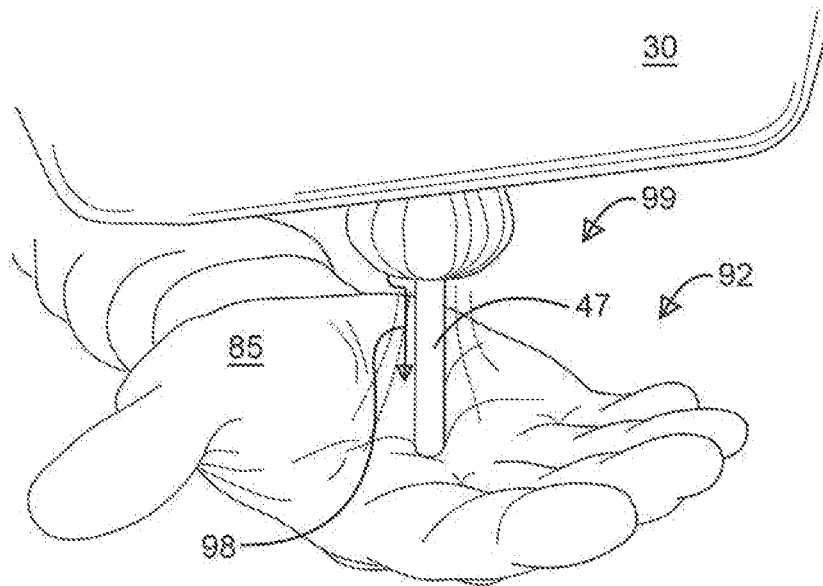
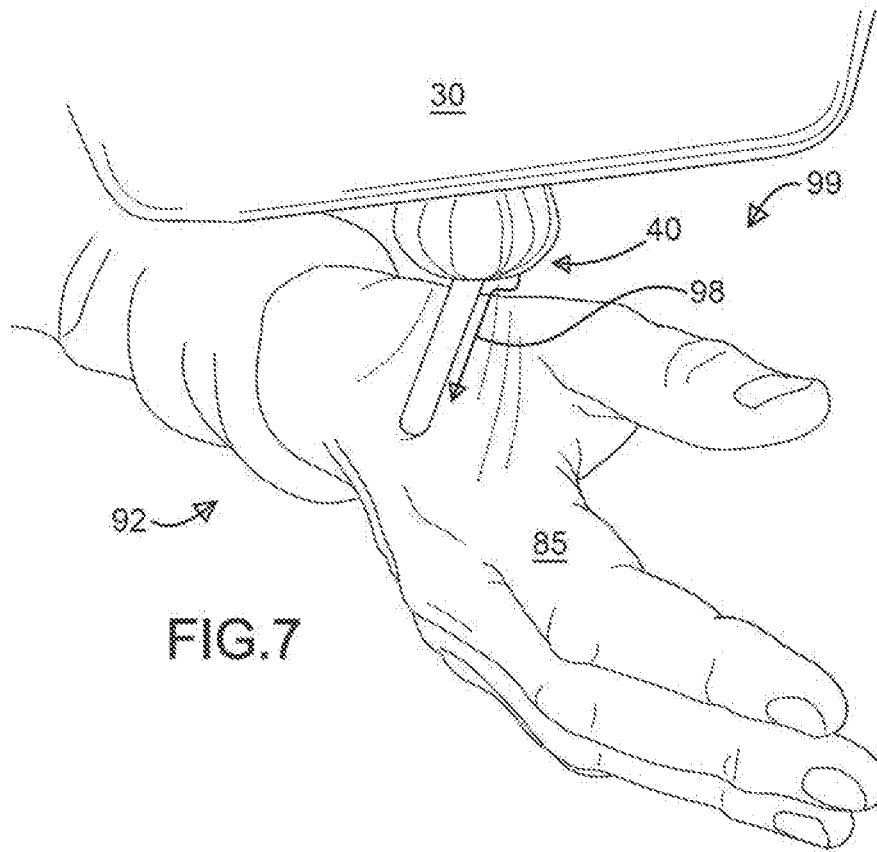

FIG.1





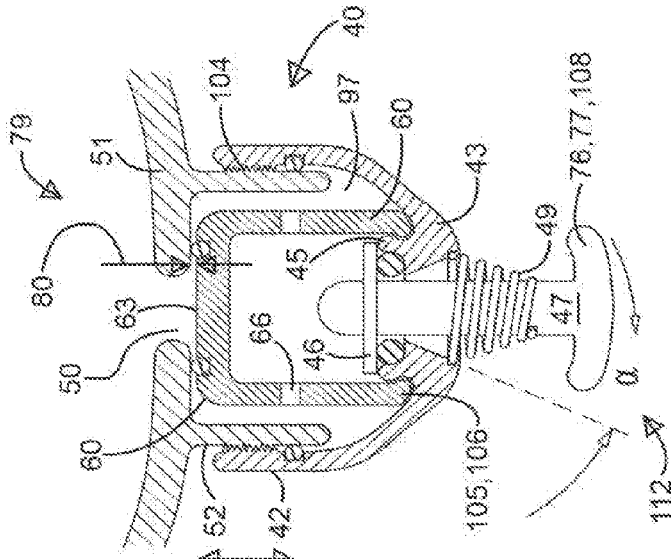

FIG.9

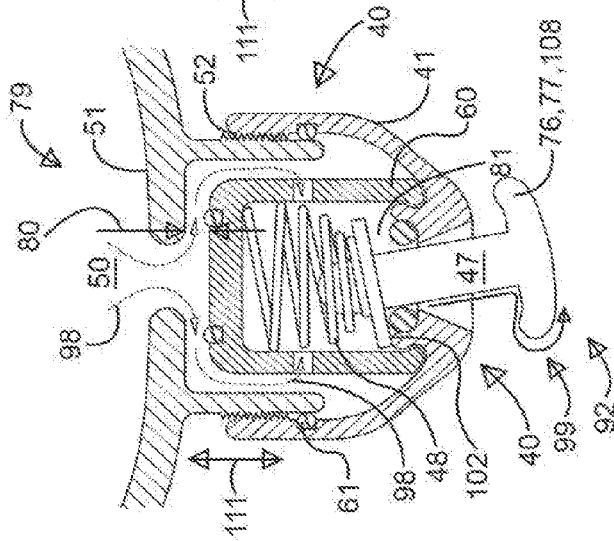

FIG.10

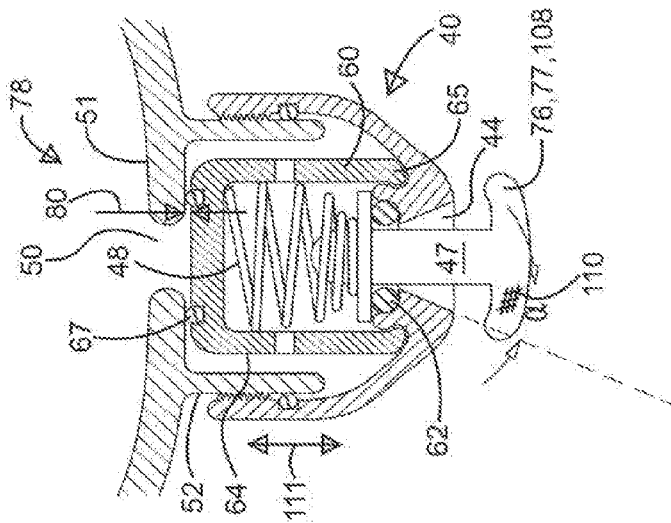

FIG.11

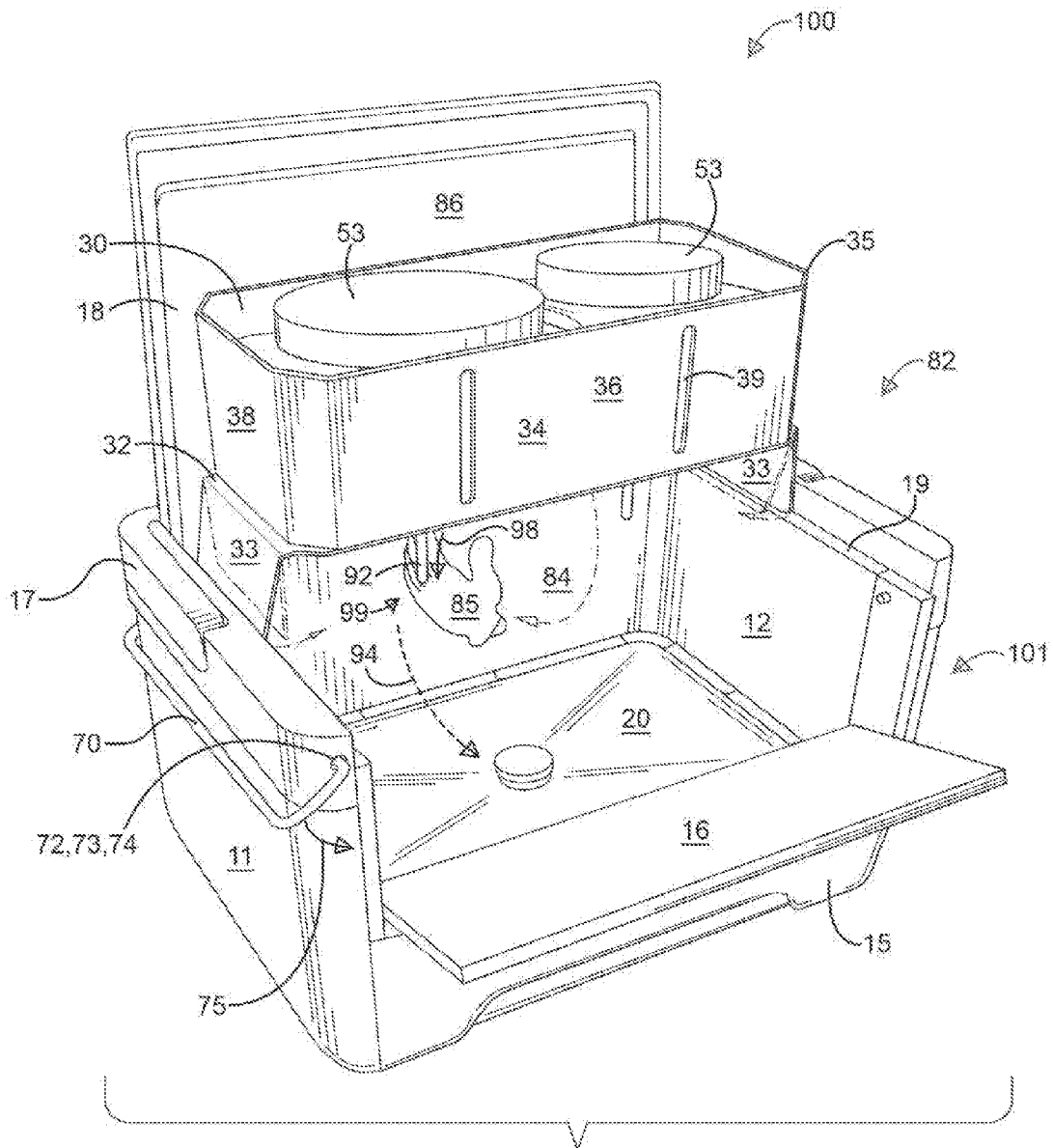

FIG. 12

PORTABLE HAND WASHING STATION

RELATED APPLICATIONS

[0001] This is a continuation in part (CIP) patent application of U.S. patent application Ser. No. 13/209,666 filed on Aug. 15, 2011 by Michael J. Littlehorn Sr. of Golden, Colo., US.

TECHNICAL FIELD

[0002] The present invention relates to hand washing equipment. In particular, it relates to a portable hand washing station.

BACKGROUND OF INVENTION

[0003] Portable hand washing equipment is desirable for use in recreational, emergency, and temporary service applications. Such equipment is well known in the art, and typically includes the essential component parts of a lavatory having a water supply and spigot to control the flow of water from a liquid flow tube.

[0004] Once such device is disclosed, in U.S. Pat. No. 1,358,937, issued to Curtiss. This device is a portable lavatory having a water receptacle. With a filler cap top opening and a swing down front tray. The receptacle includes a lower discharge opening with a water spigot for discharging water into the tray. The receptacle includes an air vent and an accessory spring clamp, for holding a towel. The tray is pivotally and slidably mounted on the receptacle, and is adapted to operate so that the air vent is closed when the tray is fastened to the receptacle in an upright vertical closed position.

[0005] Improvements to the portable lavatory concept include the addition of a hand drying apparatus. For example, in U.S. Pat. No. 5,522,411 to Johnson, discloses a portable hand washing and drying station with a front hand-receiving-opening in communication with a central hand washing compartment. Above the hand washing compartment is an upper compartment with a cleansing liquid reservoir, a spigot-controlled flow tube for delivering cleansing liquid from the reservoir to the hand washing compartment, and an electrically powered fan for air drying the hands that are washed. The reservoir and fan are supported on a shelf which slides into and out of the housing. Situated below the hand compartment is a removable waste liquid receptacle for temporarily storing the used cleansing liquid.

[0006] Another such device is disclosed in U.S. Pat. No. 7,802,327 to Mocerì et al. There, a portable and compact hand washing station is disclosed for use in training children. The station includes a main housing with a basin, a drain hole disposed in the basin, and a back splash panel projecting behind and above the basin. Support legs support the main housing. A reservoir is disposed in the back splash panel, and a spigot is in fluid communication with the reservoir. The spigot extends over and empties into the basin. When one positions one of the support legs inside a bathtub or shower, fluid entering the basin enters by gravity, from the reservoir and through the open-able spigot, exits via the drain hole, and empties into the bath tub or shower.

[0007] While the foregoing examples offer some utility, and together typify the existence of the background art as it relates to the field of the present invention, the prior art devices necessitate the use of either large water containing reservoirs and/or a plumbing connection. Moreover, such devices are difficult to clean, extremely heavy, and not easily

transported, and are easily contaminated in use from one individual to another. Moreover, they do not provide for separate cleaning and rinsing reservoirs which are interchangeable for use in a wide variety of applications, such as for the removal of grease and grime and/or for the purpose of disinfection in food service applications, emergency services, or recreational industries. Thus, what is needed is a portable hand washing station which is self-contained, easy to clean, reduces cross-contamination, but which is also easy to transport and provides low-volume and interchangeable cleaning and rinsing reservoirs for use in a wide variety of applications. The present invention satisfies these needs.

SUMMARY OF INVENTION

[0008] It is therefore an object of the present invention to provide a portable hand washing station which is self-contained, easy to clean, and reduces cross-contamination.

[0009] It is another object of the present invention to provide a portable hand washing station which is self-contained, easy to transport, and permits efficient low water volume use of cleaning and rinsing solutions in a wide variety of applications.

[0010] To overcome problems associated with the prior art, and in accordance with the purpose(s) of the present invention, briefly a portable hand washing station is provided. The portable hand washing station is contained in a durable carrying case. The case has a pair of spaced apart side walls including a first sidewall and a second sidewall connecting a bottom wall, back wall, and front wall. The case walls define an interior hand washing compartment. The front wall is adapted to include a door which is capable of opening to permit hand access into the interior of the hand washing compartment. A lid is adapted to be connected to the case in a position which is adjacent to the back wall so that the lid is capable of extending in an upright vertical position. A shelf is connected to the interior surface of the lid. The shelf has a pair of spaced apart valve openings. A pair of liquid dispensing reservoirs is supported on the shelf. Each of the reservoirs includes a top wall with a mouth opening, a bottom wall with a drain opening, and a touch operated flow valve connected to the bottom wall in liquid communication with the drain opening. The flow valves are adapted to extend in axial alignment with one of the valve openings so that a cleaning or rinsing solution is capable of being dispensed into the compartment when the flow valves are deflected by hand.

[0011] Additional advantages of the present invention will be set forth in the description that follows, and in part will be obvious from that description or can be learned or appreciated from practice of the invention. Moreover, the advantages of the invention can be realized and obtained by the invention as more particularly pointed out in the appended claims.

[0012] These and other objects of the present invention will become more readily appreciated and understood from a consideration of the following detailed description of the exemplary embodiment(s) of the present invention when taken together with the accompanying drawings, in which;

BRIEF DESCRIPTION OF DRAWINGS

[0013] FIG. 1 is a perspective view of a preferred embodiment of the hand washing station in accordance with the present invention;

[0014] FIG. 2 is a perspective view of the preferred embodiment showing the lid in a closed transportable position, the

handle in an upright carrying position, and towel bar holding the towel securely against a sidewall of the carrying case;

[0015] FIG. 3 is a perspective view of a portion of the front of the preferred embodiment showing the front door in an open position for hand access into the interior of the washing compartment, and the removable feature of the waste liquid carboy from the interior of the hand washing compartment;

[0016] FIG. 4 is a side sectional view showing one embodiment of the touch valve assembly where the touch valve includes a spring member and shut-off valve, further the drawing figure illustrates the deflection angle for discharging a cleaning or rinsing solution, and positioning of a spring member within the valve chamber so that it is disposed against the valve lever member to permit centering and pivotal movement of the valve lever head member, between a valve closed centered position and a valve open radially displaced position;

[0017] FIG. 5 is a side sectional view further illustrating the embodiment of FIG. 4 where the touch valve housing is rotated, counter-clockwise, to release the top solid portion of the cup shaped shut-off valve from the drain opening to thereby discharge a cleaning or rinsing solution through the tapered opening, and along the lever arm into the hand washing compartment;

[0018] FIG. 6 is a side sectional view of yet another embodiment of the present invention where the touch valve assembly includes a spring member disposed to press fit in an annular configuration about the lever arm so that the spring member is in compressive communication with an outer retaining lip formed at a distal portion of the inwardly tapering cylindrical opening;

[0019] FIG. 7 is an anatomical representation showing operation of the touch valve by lateral deflection, with the hand;

[0020] FIG. 8 is an anatomical representation showing operation of the touch valve by upward deflecting the touch valve, with the hand;

[0021] FIG. 9 is a side sectional view showing another embodiment of the touch valve assembly where the touch valve includes a spring member and shut-off valve, the drawing figure illustrates the deflection angle for discharging a cleaning or rinsing solution, and positioning of a spring member within the valve chamber so that it is disposed against the valve lever member that terminates in a shoe portion to permit centering and pivotal movement of the valve lever head member, between a valve closed centered position and a valve open radially displaced position;

[0022] FIG. 10 is a side sectional view further illustrating the embodiment of FIG. 9 where the touch valve housing is rotated, counter-clockwise, to release the top solid portion of the cup shaped shut-off valve from the drain opening to thereby discharge a cleaning or rinsing solution through the tapered opening, and along the lever arm that terminates in a shoe portion into the hand washing compartment;

[0023] FIG. 11 is a side sectional view of yet another embodiment of the present invention where the touch valve assembly includes a spring member disposed to press fit in an annular configuration about the lever arm so that the spring member is in compressive communication with an outer retaining lip formed at a distal portion of the inwardly tapering cylindrical opening; and

[0024] FIG. 12 is a perspective view of a preferred embodiment of the hand washing station in accordance with the present invention close to what is shown in FIG. 1 except that

the reservoirs are lowered into the reservoir rack such that the hand washing station is in its normal use scenario with the hand washing station in an open state with a user's hand using the hand washing station via deflecting the touch valve to initiate the flow of cleansing liquid with the hand positioned below the reservoirs and the user's hand is positioned above a carboy to collect a rinsate.

REFERENCE NUMBERS IN DRAWINGS

- [0025]** 10 Outer carrying case
- [0026]** 11 First side wall of case 10
- [0027]** 12 Second side wall of case 10
- [0028]** 13 Bottom wall of case 10
- [0029]** 14 Back wall of case 10
- [0030]** 15 Front wall of case 10
- [0031]** 16 Front door of case 10
- [0032]** 17 Handle of case 10
- [0033]** 18 Lid of case 10
- [0034]** 19 Horizontal lip of case 10
- [0035]** 20 Carboy
- [0036]** 21 Outer periphery of the carboy 20
- [0037]** 22 Slidable contact of the outer periphery 21 to sidewalls 11, 12, 14, and 15
- [0038]** 23 Seal for carboy 20 outer periphery 21 that is a peripheral elastomeric seal
- [0039]** 24 Top wall of the carboy 20
- [0040]** 25 Stopper of the carboy 20
- [0041]** 29 Clear holes or valve openings
- [0042]** 30 Primary reservoir
- [0043]** 31 Secondary reservoir
- [0044]** 32 Shelf
- [0045]** 33 Flat spring end members
- [0046]** 34 Bottom wall of the reservoir rack 35
- [0047]** 35 Reservoir rack for the primary 30 and secondary 31 reservoirs
- [0048]** 36 Front wall of the reservoir rack 35
- [0049]** 37 Back wall of the reservoir rack 35
- [0050]** 38 Side wall of the reservoir rack 35
- [0051]** 39 Spaced apart slots
- [0052]** 40 Touch valve assembly
- [0053]** 41 Internally threaded valve housing
- [0054]** 42 Proximal end portion of the valve housing 41
- [0055]** 43 Distal end portion of the valve housing 41
- [0056]** 44 Inwardly tapering cylindrical opening of the valve housing 41
- [0057]** 45 Annular valve seat of the valve housing 41
- [0058]** 46 Valve head member
- [0059]** 47 Valve lever arm
- [0060]** 48 Internal spring that is disposed within the central chamber 97 and compresses against the valve head 46 and the reservoir bottom wall 51 or the cup shaped valve 60
- [0061]** 49 External spring that has a press fit about the lever arm 47 and compresses against the inwardly tapering cylindrical opening 44
- [0062]** 50 Central drain opening in the primary 30 and secondary 31 reservoirs
- [0063]** 51 Bottom wall of the reservoirs 30, 31
- [0064]** 52 Annular threaded flange of the bottom wall 51
- [0065]** 53 Screw cap of the reservoirs 30, 31
- [0066]** 60 Cup shaped shut off valve
- [0067]** 61 First o-ring
- [0068]** 62 Second o-ring
- [0069]** 63 Top surface of the shut off valve cup 60
- [0070]** 64 Circumferential sidewall

[0071] 65 Distal annular flange
 [0072] 66 Plurality of openings
 [0073] 67 Third o-ring
 [0074] 70 An elongated rod in the form of a "C" shape that has a pivotal attachment to the sidewall 11 and/or 12 with the rod 70 used as a towel 96 bar
 [0075] 71 Pulling of the towel 96
 [0076] 72 Pair of ends of the elongated rod 70
 [0077] 73 Pivotal attachment of each end 72
 [0078] 74 Means for urging the elongated rod 70 to be in contact with the sidewall 11 and/or 12 via pivotal movement 75 wherein the means 74 is preferably a torsional or rotational coil spring
 [0079] 75 Movement of the pivotal attachment 73
 [0080] 76 Distal end of the valve lever arm 47
 [0081] 77 Distal end of the valve lever arm 47 sized and configured as a shoe
 [0082] 78 Closed valve 40 channel state when the top surface 63 is in contact with the bottom wall 51 of the reservoir 30, 31 drain 50 resulting in distance 80 equaling zero
 [0083] 79 Open valve 40 channel state when the top surface 63 is spaced away a distance 80 from the bottom wall 51 of the reservoir 30, 31 drain 50 resulting in distance 80 being greater than zero
 [0084] 80 Distance from the top surface 63 to the bottom wall 51 of the reservoir 30, 31 drain 50, the distance 80 which goes from zero in state 78 to a selected distance 80 in state 79 to regulate flow 98 in valve 40 positioned in the open state 99
 [0085] 81 Annular gap for water flow
 [0086] 82 Open state of the portable hand washing station assembly
 [0087] 83 Closed state of the portable hand washing station assembly
 [0088] 84 Interior hand washing compartment
 [0089] 85 Hand
 [0090] 86 Interior surface of the lid 18
 [0091] 87 Pivot attachment of lid 18 to back sidewall 14
 [0092] 88 Interior surface of the sidewalls 11, 12, 14, and 15
 [0093] 89 Compressing flat spring member 33 with compressible movement
 [0094] 90 Top wall of reservoir 30, 31
 [0095] 91 Mouth opening of reservoir 30, 31
 [0096] 92 Deflection of flow valve 40 by the hand 85
 [0097] 93 Funnel shaped opening if the carboy 20
 [0098] 94 Rinsate
 [0099] 95 Drain opening of the carboy 20
 [0100] 96 Towel
 [0101] 97 Central chamber of the valve housing 41
 [0102] 98 Flow of water
 [0103] 99 Open flow 98 state of the valve 40 from deflection 92
 [0104] 100 Portable Hand Washing Station Assembly
 [0105] 101 Interior of case 10 as a hand washing compartment in open state 82
 [0106] 102 Pivotal fulcrum
 [0107] 103 Flow annular gap
 [0108] 104 Threaded connection of valve housing 41 resulting in movement 111 of the valve housing 41 relative to the flange 52 when the housing 41 is rotated
 [0109] 105 Affixment of the distal annular flange 65 to valve seat 45
 [0110] 106 Snap fit removable engagement of the affixment 105

[0111] 107 Longwise rod of lever arm 47
 [0112] 108 Shoe of lever arm 47
 [0113] 109 Water flow 98 to stay in contact with lever arm 47
 [0114] 110 Surface roughness of the lever arm 47
 [0115] 111 Movement of the threaded connection 104
 [0116] 112 Closed no flow 98 state of the valve 40 from no deflection 92
 [0117] 113 Removable engagement interface of the top wall 24 to the outer periphery 21 of the carboy 20 to make the top wall 24 removable for carboy 20 cleaning

DETAILED DESCRIPTION

[0118] Although, many methods and materials which are similar or equivalent to those described herein, can be used in the practice or testing of the present invention, the preferred methods and materials are now described. Reference will now be made in detail to the presently preferred embodiments of the invention, including the examples of which are illustrated with the accompanying drawings. In the drawings, like numerals will be used in order to represent the like features of the invention.

[0119] The present invention provides a portable hand washing station 100 for use in a wide variety of applications. The hand washing station 100 is constructed with a durable outer carrying case 10. The carrying case 10 is preferably a double wall insulated construction formed of a molded plastic. For example, the case 10 is even more desirably constructed of a durable marine grade polyethylene so that the interior and exterior surfaces are easy to wipe clean after each use. In the presently preferred embodiment, the case 10 has an exterior dimension of 33×24.13×22.53 centimeters (L×W×H), with an interior volume of approximately 8 liters. In this configuration, the case 10 is molded in a rectangular box like shape for ease in positioning on a table, and for stacking and storage. The case includes a pair of spaced apart side walls being a first side wall 11 and a second side wall 12 connecting a bottom wall 13, back wall 14, and a front wall 15. The walls 11, 12, 13, 14, and 15 are preferably molded so that the case 10 is a one-piece water-tight shell construction. These walls 11, 12, 13, 14, and 15 define an interior hand washing compartment 84.

[0120] The front of the carrying case 10 is adapted to include a front door 16. The door 16 is of sufficient size and shape so that it is capable of opening to allow hand 85 access into the interior 84 of the hand 85 washing compartment. As shown in the drawing Figures and in the presently preferred embodiment, the door 16 is pivotally attached to the inner surface or the first 11 and second 12 side walls so that it opens on a horizontal axis. With this configuration the front wall 15 of the case 10 is the truncated lower portion of the front of the case 10. The door 16 of the upper portion is preferably constructed from a one centimeter thick sheet of durable super high density polyethylene, similar to a cutting board, which is pivotally attached to the interior of the first 11 and second 12 side walls of the case. In this manner, the lower portion of the front wall 15 remains rigidly formed as an integral construction with the first 11 and second 12 side walls and bottom wall 13 of the case 10, and is configured so that it is slightly taller than the vertical depth of the waste containing carboy 20. The lower portion thereby creates an inner chamber for containing and securing the waste 94 containing carboy 20 in the bottom of the case 10, but also extends sufficiently above the carboy 20 to act as a water containing basin, in use, so that water does

not flow out of the compartment **84**. Finally, the case preferably includes an integrated swing-up handle **17**. The handle **17** is attached to the case **10** at a location which is adjacent to the first **11** and second **12** side walls for ease in carrying.

[0121] A lid **18** is provided for covering the interior compartment **84** of the case **10**. The lid **18** may either be pivotally **87** attached to the case **10** or designed as a separate lift-off top, but, in any event, the lid **18** is necessarily designed so that it is capable of vertical support, adjacent to the back wall **14** of the case **10**, in an upright open position **82** for accessing the interior **84** of the compartment, supporting the primary **30** and secondary **31** reservoirs, and alternately covering the compartment **84** in order to secure the hand washing station **110** for travel and storage.

[0122] It is preferable to construct the case **10** and lid **18** as an assembly so that the lid **18** is in pivotal connection **87** with an interior surface **88** of the first **11** and second **12** side walls. For this embodiment, either the lid **18**, or the first **11** and second **12** side walls typically will include a combination of corresponding pivot pins and/or pivot pin receiving holes aligned so that they are adjacent to the back wall **14**. Again, an important feature of the present invention **100**, as it relates to the lid **18**, is that the lid **18** is simply adapted to be capable of support, on the case **10** in an upright vertical position. The lid **18** is also constructed so that it has a rigid interior surface for either attaching a shelf **32** or for including a shelf **32** as a component of the lid **18** in an integral molded construction.

[0123] The shelf **32** is attached to the interior surface of the lid **18**. The shelf **32** desirably includes a pair of spaced apart clear holes **29** for receiving the touch valves **40**. The shelf **32** is thereby dimensioned so that it is capable of fitting into the compartment interior **84** when the lid **18** is pivoted downwardly in a compartment enclosing or covering position. The shelf **32** is attached to the interior surface of the lid **18**, in any manner which is well known in the art, including molding the lid **18** and shelf **32** as a one-piece assembly or attaching the lid **18** with adhesives or fasteners.

[0124] As shown in the drawing Figures, and in accordance with the presently preferred embodiment, the lid **18** is pivotally attached **87** to the first **11** and second **12** side walls of the case **10**. In addition a horizontal lip **19** is formed in an upper interior surface **88** of each of the first **11** and second **12** side walls and the shelf **32** further includes a pair of transverse bends or folds. The folds, or bends in the shelf sheet stock define a pair of oppositely aligned flat-spring end members **33**. The spring end members **33** are adapted to project downwardly at a first extended angle so that the ends **33** are capable of engaging the lip **19** formations when the lid **18** is pivoted to an open vertical position. In this manner, the spring end members **33** act as support legs which serve to support the primary **30** and secondary **31** reservoirs, the shelf **32**, and the lid **18** in an upright open vertical position. In use the flat-spring end members **33** are compressible, to a second angle, so that the spring members **33** are capable of releasing **89** support legged engagement from the lip **19** formations. Release **89** of the spring members **33** is easily performed with the fingers, of the hand **85**, by slightly lifting the shelf with the palm of the hand and pinching the ends inwardly with the fingers, in order to permit the lid **18** to pivot downwardly into an closed position state position **83**, for transport and storage of the hand washing station **100**.

[0125] In an even more preferred embodiment of the present invention **100** and as illustrated in the drawing Figures, the interior of the hand washing compartment **84** further

includes a reservoir rack **35**. The reservoir rack **35** may be constructed of a thin sheet of steel but is desirably constructed as a single molded plastic body. The rack **35** has at least a front **36**, back **37**, and side walls **38**. The back wall **37** is connected to the interior surface of the lid **18** so that the rack **35** may be secured in relation to the shelf **32**, and is thereby capable of preventing movement of the primary **30** and secondary **31** reservoirs when the hand washing station **100** is subjected to a lateral force, when the lid **18** is positioned in either an open **82** or a closed **83** position. The front wall **36** of the rack **35** may also, but need not, include a pair of spaced apart clear slots **39** which are positioned so that the slots **39** permit viewing of a graduated liquid contents contained in the primary **30** and secondary **31** reservoirs. Finally, the rack **35** may include the bottom wall **34** as shown in the drawing Figures so that the rack **35** is a single molded box-like plastic body with an open top, for inserting and removing the primary **30** and secondary **31** reservoirs. Here, the bottom wall **34** also includes another pair of spaced apart clear holes, positioned in axial alignment with the valve opening clear holes **33** in the shelf **32** for receiving the touch valves **40**.

[0126] A pair of liquid dispensing reservoirs being the primary **30** and secondary **31** reservoirs are supported on the shelf **32**. The primary reservoir **30** can be used for containing the rinsing solution and the secondary reservoir **31** can contain the cleaning solution. In the preferred embodiment the cleaning solution is an aqueous soap solution and the rinsing solution is water. The primary **30** and secondary **31** reservoirs are preferably configured as a molded bottle shaped body which is formed from a transparent NALGENE, polypropylene, polyethylene, or polycarbonate material, in a manner which is very similar to those which one would ordinarily associate as offered for sale by chemical laboratory supply companies for use by chemical laboratory professionals. Wide-mouth bottles formed of these materials are particularly suitable, for use with the present invention, because they are easy to clean and are even amenable to high temperature, pressure, or chemical sanitization and/or sterilization depending on the intended use, as in circumstances where the desired use represents a potential for bio-hazardous contamination.

[0127] As above the primary **30** and secondary **31** reservoirs are preferably formed in a wide-mouth screw capped bottle configuration with a central drain opening **50** in the bottom wall. As shown in the drawing Figures, the bottom wall **51** of the reservoirs **30**, **31** preferably includes an externally threaded annular flange **52** portion, configured about the drain opening **50** for threadably connecting of the touch operated flow valves **40**. The threaded connection permits upward and downward dislocation **111** of the flow valves **40** which permits the use and operation of the cup-shaped shut-off valve **60** as more fully described below.

[0128] The wide mouth opening in the top wall also includes an externally threaded flange portion for attaching a screw cap **53**. In use the screw cap **53** is easily loosened in order to vent the liquid contents of the reservoirs **30**, **31** so that the liquid contents are capable of discharge through the drain openings **50**. The annular flange **52** portions, in the bottom walls **50** of the reservoirs **30**, **31** are necessarily formed so that they are capable of extending downwardly in axial alignment with the valve openings **29** in the shelf **32** and/or reservoir rack **35**. Each of the reservoirs **30**, **31** includes the touch operated flow valve **40** in threaded connection **104** to the threaded **52** bottom wall **51** to permit liquid communication

with the drain opening 50. Finally, the primary reservoir 30 and the secondary reservoir 31 are desirably scaled to contain different volumetric amounts. In particular it is preferred that the primary rinsing reservoir 30 is designed to hold twice the volume of the secondary cleaning reservoir 31.

[0129] Referring now, in particular, to the embodiments shown in FIGS. 4 to 6, the touch operated flow valves 40 include an internally threaded valve housing 41 which, in turn is threaded 104 onto the externally threaded flange 52 portion of the bottom wall 34 of the reservoirs 30, 31. The valve housing 41 has a central chamber 97, a proximal end 42 adapted for connection 10 the drain opening 50, a distal end 43 formed with an inwardly tapering cylindrical opening 44, and an interior wall formed with an annular valve seat 45. The touch operated flow valve 40 has a valve lever member, centrally mounted in the chamber. The valve lever member is formed with an annular valve head member 46 and a valve lever arm 47. The valve head member 46 is adapted to water seal against the valve seat 45. The lever arm 47 is dimensioned to extend through the inwardly tapering opening 44, into the interior of the hand washing compartment, so that a flow of water is permitted to pass between the valve lever arm 47 and the inwardly tapering opening 44 while the distal end of the lever arm 47 is deflected by hand. The inwardly tapering opening 44 is preferably constructed with an inwardly sloping conical surface so that it opens 99 fully with angular deflection (as shown in drawing FIGS. 5 and 10) of less than 25 degrees. The proximal end 42 of the valve housing 41 includes a first O-ring 61 fitted between the interior threaded portion of the proximal end 42 of the valve housing 41 and the external surface of the bottom wall 51 flanged portion 52, in order to water-seal the valve housing 41 in relation to the reservoir 30, 31 drain opening 50. A second O-ring 62 is disposed between the valve seat 45 formation and the valve head 46, of the lever member to provide a water-seal between the valve head member 46 and the valve seat 45 when the lever arm 47 is positioned in a central position. A third O-ring 67 is fitted between the top surface 63 of the shut-off valve 60 and the bottom wall 51 of the reservoir.

[0130] As mentioned above where the touch operated flow valves 40 are embodied to threadably connect to the flange portion 52 of the bottom wall 51, the touch valve 40 may, but need not further include an internal inverted cup-shaped shut-off member 60 disposed annularly about the drain opening 50. The shut-off valve 60 is defined with a solid top surface 63 which biases against and to seal, the drain opening 50 and a circumferential sidewall 64 with a distal annular flange 65. The circumferential side wall 64 includes a plurality of openings 66 such as holes or slots for channeling the cleaning and rinsing solutions 98 into the central chamber 97 of the valve housing 41. The distal annular flange 65 or lip, shaped portion is adapted to snap-fit 106 a complimentary formation in the inner wall of the central chamber 97 so that shut-off valve 60 operates in open 79 and closed 78 cooperation with the valve housing 41 when the valve housing 41 is rotated in a counter clockwise and clockwise directions respectively causing movement 111.

[0131] The shut-off valve 60 is adapted to cooperate with the valve housing 41 to open 79 and close 78 open channel flow 98 into the central chamber 97. When the touch valve 40 is rotated in a tightened, or clockwise direction, the solid top surface 63, of the shut-off valve 60 biases against the drain opening 50 so that the liquid now is stopped and contained in a closed channel condition 78 wherein distance 80 equals

zero. When the touch valve 40 is loosened, in a counter-clockwise direction the solid top surface 63 of the shut-off valve 60 is disposed in a spaced relationship via distance 80 below the drain opening 50 so that an open channel condition 79 permits liquid flow 98 of solution into the central chamber 97, of the touch valve housing 41, and permits dispensing of the liquid 98 for hand 85 washing when the lever arm 47 is deflected by hand 85.

[0132] Thus by connecting the distal portion of the shut-off valve 60, about the annular valve seat 45 to the inner wall of the valve housing 41, and threading 104 the valve housing 41 onto the bottom wall 51 of the reservoir 30, 31, one may alternately rotate the valve housing 41 to either engage 78 or disengage 79 the shut-off valve 60 from the drain opening 50. It follows that, in operation rotation of the valve housing 41 in this manner, further permits one to meter or control the flow 98 of the liquid contents, of the reservoirs, in proportion to the degree of rotation of the valve housing 41. This feature is particularly useful, in providing flexibility, in applications where one intends to use differing concentrations, or formulations, of cleaning solutions in relation a volume of rinsing solution.

[0133] The shut-off valve member 60 includes a plurality of openings 66 in the sidewall 64 to permit the flow of liquid from the drain opening 50 of the reservoirs 30, 31, past the top solid surface 63 of the shut-off valve 60, through the openings 66 in the sidewall 64, and into the central chamber 97 of the valve housing 41. The dashed line illustrations in FIGS. 5 and 10 show this flow pattern in accordance with this embodiment. Thus in FIGS. 5 and 10 when the valve housing 41 is rotated to a loosened position and the shut-off valve 60 is disposed downwardly, so that the top solid surface 63 is disengaged from the drain opening 50 via distance 80 in open state 79, and liquid flows 98 through the clear openings 66 in the circumferential sidewall 64, of the shut-off valve 60 and into the central chamber 97 for dispensing when the lever arm 47 is deflected 92 by hand 85. This operation by deflection is further illustrated in drawing FIGS. 7, 8, and 12.

[0134] Referring again to drawing FIGS. 4 to 6 and 9 to 11, the touch operated flow valve 40 also includes a spring member 48 or 49 that is either internal 48 or external 49 which is capable of biasing against the valve lever member to permit centering and pivotal movement 102 of the valve lever head member 46, within the chamber 97, between a valve closed 112 and centered position and a valve open 99 and radially displaced position. These drawing Figures illustrate two of the presently preferred embodiments for positioning of the spring member 48, 49 in relation to the valve lever member. In the first embodiment, of FIGS. 4, 5, 9, and 10 the spring member 48 is disposed in the central chamber 97 and is adapted to annularly compress against the valve head 46 and the cup 60. With the second embodiment, of FIGS. 6 and 11, the spring member 49 is positioned to press fit about the lever arm 47 so that it is capable of making a compressive communication with the inwardly tapering cylindrical opening 44.

[0135] As mentioned briefly above, a waste liquid carboy 20 is disposed adjacent to the bottom wall 13 of the compartment, in a spaced relationship below the touch operated flow valves 40. The waste liquid carboy 20 is also preferably constructed as a plastic molded body which fanned of transparent NALGENE, polypropylene, polyethylene, or polycarbonate materials. The carboy 20 is further dimensioned in a configuration so as to permit a substantially water tight fit via the slidable contact 22 against the interior surfaces 88 of the

back 14, side 11, 12, and the lower portion of the front wall 15 of the carrying case 10. In the alternative, the periphery 21 of the carboy 20 may, but need not, further include a peripheral water seal 23, such as a plastic or rubber nap or skirt which biases against the interior surfaces 88 of the carrying case 10.

[0136] The waste liquid carboy 20 has a top wall 24 with a funnel shaped 93 draining to the opening 95 so that it is adapted to collect the contaminated rinsate 94 from the hands 85. The carboy 20 is removable, by lifting from the interior of the compartment 84 for disposal of the rinsate 94 and cleaning of the carboy 20. The carboy 20 desirably includes a stopper 25 or cap. Where the intended use is in conjunction with normal hand 85 washing applications, the carboy 20 desirably includes a drain opening (not shown) in a bottom wall. However, as mentioned above the present invention 100 is also designed for use in an emergency, or bio-hazardous conditions, where the carboy 20 is simply capped and disposed of with a new carboy 20 retrofit in the interior 84 of the case 10 compartment.

[0137] Finally it is also desirable to further include a towel bar 70 which is pivotally 73 attached to the case 10 or side-walls 11 and/or 12. The towel bar 70 may, but need not, include a cam actuated bar-end member in pivotal attachment 73 with the carrying case 10 so that in use, the towel bar 70 biases or urges 75 compressively downward against an exterior surface of a side wall 11 and/or 12, via means 74 so that the towel bar 70 secures the towel 96 against pulling 71 or tearing with a drying motion by hand 85 or by wind in the environment.

CONCLUSION

[0138] Accordingly, the present invention of the portable hand washing station has been described with some degree of particularity directed to the embodiment(s) of the present invention. It should be appreciated, though; that the present invention is defined by the following claims construed in light of the prior art so modifications or changes may be made to the exemplary embodiment(s) of the present invention without departing from the inventive concepts contained therein.

1. A portable hand washing station, comprising:

(a) a durable carrying case including a pair of spaced apart sidewalls that include a first side wall and a second side wall, a back wall, and a front wall, all connecting to a bottom wall, said walls defining an interior hand washing compartment, and whereby said front wall is adapted to include a door capable of opening to permit hand access into said interior of the hand washing compartment;

(b) a lid adapted to be connected to said case, wherein said lid is capable of support on said case in an open vertical position, and wherein said lid further includes a shelf connected to an interior surface of said lid, said shelf having a pair of spaced apart valve openings, wherein said lid is pivotally attached to said sidewalls of the case, a horizontal lip is formed in an upper interior surface of each of said sidewalls, and said shelf further includes a pair of transverse folds defining a pair of oppositely aligned flat spring end members adapted to project downwardly at a first extended angle capable of engaging said lip formations when said lid is pivoted to an open vertical position, said flat spring end members are compressible to a second angle so that said flat spring members are capable of releasing engagement from said

lip formations to permit said lid to pivot downwardly into an enclosing position for transport and storage; and

(c) a pair of liquid dispensing reservoirs supported on the lid including a primary reservoir and a secondary reservoir, each of said reservoirs including a top wall including a mouth opening, a bottom wall including a drain opening, and a touch operated flow valve connected to the bottom wall in liquid communication with said drain opening, wherein said flow valves are adapted to extend into said interior hand washing compartment when said flow valves are deflected by hand, wherein said flow valves are capable of extending through said valve openings into the interior of the compartment, wherein operationally when said lid is placed into said open vertical position defined as an open state of said portable hand washing station, said pair of reservoirs are elevated to provide space within said case interior wherein with said door open creating said interior hand washing compartment thus giving access to hands for utilizing said touch flow valves and further a closed state of said portable hand washing station defined as said lid being in said downward and enclosed position for transport and storage wherein said reservoirs are lowered into said case interior.

2. The portable hand washing station according to claim 1, further comprising a waste liquid carboy disposed adjacent to said bottom wall of said compartment in a spaced relationship below said touch operated flow valves, said waste liquid carboy including a top wall with a funnel shaped opening adapted to collect a rinsate from said valves and said reservoirs.

3. The portable hand washing station according to claim 2, wherein said carboy further includes an outer periphery that is in a slidable contact with said first side wall, said second side wall, said back wall, and said front wall, wherein a peripheral elastomeric seal is disposed at said slidable contact, wherein operationally said seal further helps prevent the rinsate from going in-between said carboy and said walls.

4. The portable hand washing station according to claim 3, wherein said carboy further includes a drain opening and said funnel shaped opening includes a stopper, further included in said carboy is a removable engagement interface in-between said top wall and said outer periphery that is operational to facilitate said top wall to be removable from said outer periphery for cleaning of said carboy.

5. The portable hand washing station according to claim 1, further comprising an elongated rod having a pair of ends, wherein said elongated rod is formed in the shape of a "C", wherein each said end is pivotally attached to said sidewall, further included is a means for urging said elongated rod to be in contact with said sidewall via a movement through said pivotal attachments, wherein operationally said elongated rod acts as a drying towel bar that through said means for urging clamps a towel as between said elongated rod and said sidewall to keep the towel in place in windy environmental conditions.

6. The portable hand washing station according to claim 1, wherein each of said dispensing reservoirs are transparent and said mouth opening of each reservoir is a screw cap assembly.

7. The portable hand washing station according to claim 1, wherein said pair of dispensing reservoirs include a cleansing liquid reservoir and a rinsing liquid reservoir, said reservoirs are dimensioned in volume so that said cleansing liquid res-

ervoir contains a volume in a range of one-third to two-thirds a volume of said rinsing liquid reservoir.

8. The portable hand washing station according to claim **1**, wherein said touch operated flow valves include a valve housing formed with a central chamber, a proximal end adapted for connection to said drain opening, a distal end formed with an inwardly tapering cylindrical opening, and an interior wall formed with an annular valve seat, said touch operated flow valve further including a valve lever member, centrally mounted in said chamber, including an annular valve head member and a valve lever arm, wherein said valve head member is adapted to water seal against said valve seat, and said lever arm is dimensioned to extend through said inwardly tapering opening into said interior of said washing compartment so that a flow of water is permitted to pass between said valve lever arm and said inwardly tapering opening when said distal end of the lever arm is deflected by a hand.

9. The portable hand washing station according to claim **8**, wherein said touch operated flow valve further comprises a spring member capable of biasing against said valve lever member to permit centering and pivotal movement of said valve lever head member within said chamber between a valve closed centered position and a valve open radially displaced position.

10. The portable hand washing station according to claim **9**, wherein said spring member is disposed in said central chamber and is adapted to annularly compress as against said valve head from said reservoir bottom wall.

11. The portable hand washing station according to claim **9**, wherein said spring member is positioned to press fit about said lever arm in compressive communication with the inwardly tapering cylindrical opening.

12. The portable hand washing station according to claim **1**, wherein said interior of said hand washing compartment further includes a reservoir rack having a front, a back, and side walls, wherein said back wall is connected to an interior surface of said lid so that said rack is secured on said shelf and is thereby capable of preventing movement of said reservoirs when said portable hand washing station is subjected to a lateral force.

13. The portable hand washing station according to claim **12**, wherein said front wall of said rack includes a pair of spaced apart clear slots positioned so that said slots permit viewing of a graduated liquid volume contained in said reservoirs.

14. A portable hand washing station, comprising:

- (a) a durable carrying case including a pair of spaced apart sidewalls that include a first side wall and a second side wall connecting a bottom wall, a back wall, and a front wall, said walls defining an interior hand washing compartment, and whereby said front wall is adapted to include a door capable of opening to permit hand access into said interior of the hand washing compartment;
- (b) a lid adapted to be connected to said case;
- (c) a pair of liquid dispensing reservoirs supported on said lid, including a primary reservoir and a secondary reservoir, each of said reservoirs including a top wall having a mouth opening and a bottom wall including a drain opening; and
- (d) a touch operated flow valve connected to said bottom wall in liquid communication with said drain opening, each said flow valve including a valve housing formed with a central chamber, a proximal end adapted for connection to said drain opening, a distal end formed with

an inwardly tapering cylindrical opening forming a portion of a frustroconical shape that is a symmetrically continuous opening, and an interior wall formed with an annular valve seat protrusion shaped as an annular continuous raised ridge, said touch operated flow valve including a valve lever member centrally mounted in said chamber therethrough said inwardly tapering cylindrical opening, said valve lever member including an annular valve head member and a valve lever arm, wherein said valve head member is adapted to water seal against said valve seat, and said lever arm is dimensioned to extend through said inwardly tapering opening into said interior of said washing compartment, wherein operationally a flow of water is permitted to pass between said valve lever arm and said inwardly tapering opening when a distal end of said lever arm is deflected by hand in an omnidirectional manner.

15. The portable hand washing station according to claim **14**, wherein each said flow valve annular continuous raised ridge peripherally circumferentially nests a second o-ring, forming said water seal as between said valve head and said valve seat, wherein operationally when said lever arm is laterally deflected by hand in an omnidirectional manner said annular valve head has a pivotal fulcrum upon a furthermost extension of said annular continuous raised ridge such that said second o-ring is freely uncompressed forming a peripheral continuous flow annular flow gap for water flow as between said second o-ring and said annular valve head.

16. The portable hand washing station according to claim **15** wherein each of the pair of dispensing reservoirs touch operated flow valves said valve housings have a threaded connection to a reservoir drain opening having an annular threaded flange on said reservoir bottom wall, and each said touch valve further includes an internal plug shut-off cup having a top surface, said internal plug shut-off cup having a top surface also further includes a distal annular flange that has an affixment to said valve seat, said shut-off cup is adapted to cooperate in communication with said drain opening so that a liquid flow from said drain opening is shut-off in a closed channel state being defined as said top surface contacting said reservoir drain, when each of said touch valves are rotated to a tightened position via said threaded connection, and the liquid flow is in an open channel flow condition when each of said valves is rotated to a loosened position via said threaded connection resulting in an open channel state defined as said top surface having a distance from said reservoir drain, further operationally said distance may be varied via rotating said touch valves via said threaded connection to adjust a flow-rate from said reservoir in said open channel flow condition.

17. The portable hand washing station according to claim **16** wherein said affixment is sized and configured to be a snap fit removable engagement to facilitate said internal plug shut-off cup to be removable from said valve housing when said valve housing is unthreaded from said reservoir drain opening further facilitating said valve head and said valve lever arm to be removed from said inwardly tapering cylindrical opening, wherein operationally said touch operated flow valve can be completely disassembled and separated from said annular threaded flange of said bottom wall of said reservoir to facilitate complete cleaning of said reservoir and said touch operated flow valve and to facilitate replacement of said valve or said reservoir.

18. The portable hand washing station according to claim 14 wherein said valve lever arm extends away from said inwardly tapering cylindrical opening forming a longwise rod that terminates in a distal end portion to be operationally deflected by hand in an omnidirectional manner to initiate the flow of water to pass between said valve lever arm and said inwardly tapering opening.

19. The portable hand washing station according to claim 14 wherein said valve lever arm extends away from said inwardly tapering cylindrical opening terminating in a shoe portion to be operationally deflected by hand in an omnidirectional manner to initiate the flow of water to pass between said valve lever arm and said inwardly tapering opening.

20. The portable hand washing station according to claim 15 wherein said annular flow gap for water flow is sized and configured to cause the water flow to stay in contact with said valve lever arm via cohesion of the water to itself and a higher level of adhesion of the water to said valve lever arm from said valve lever arm having a surface roughness that causes the water adhesion to be greater than the water cohesion, thus operationally causing the water to flow in contact with said valve lever arm and to not separate from said valve lever arm thus minimizing loss of water to an external environment away from said valve lever arm to minimize usage of water for hand washing.

* * * * *