



US 20140227043A1

(19) **United States**

(12) **Patent Application Publication**  
**Seegmiller**

(10) **Pub. No.: US 2014/0227043 A1**

(43) **Pub. Date: Aug. 14, 2014**

(54) **APPARATUS AND METHOD FOR  
INSTALLING GROUND ANCHORING  
SYSTEMS**

part of application No. 13/178,325, filed on Jul. 7,  
2011, now Pat. No. 8,235,147.

**Publication Classification**

(71) Applicant: **Ben L. Seegmiller**, Salt Lake City, UT  
(US)

(51) **Int. Cl.**  
**E21D 21/00** (2006.01)  
**E21B 3/00** (2006.01)

(72) Inventor: **Ben L. Seegmiller**, Salt Lake City, UT  
(US)

(52) **U.S. Cl.**  
CPC .. **E21D 21/00** (2013.01); **E21B 3/00** (2013.01)  
USPC ..... **405/259.1**; 175/57

(21) Appl. No.: **14/259,077**

(22) Filed: **Apr. 22, 2014**

(57) **ABSTRACT**

**Related U.S. Application Data**

(63) Continuation-in-part of application No. 13/736,538,  
filed on Jan. 8, 2013, which is a continuation of appli-  
cation No. 13/351,085, filed on Jan. 16, 2012, now Pat.  
No. 8,347,987, which is a continuation-in-part of  
application No. 13/233,613, filed on Sep. 15, 2011,  
now Pat. No. 8,302,706, which is a continuation-in-

An apparatus and method for forming a borehole in an earthen  
formation includes a side cutting device comprised of a lat-  
erally extendable side cutting element that can be actuated  
from a retracted position to an extended position in which the  
side cutting element is selectively employed to create a larger  
borehole diameter in a down hole location than the remaining  
portion of the borehole that is closer to the borehole opening.

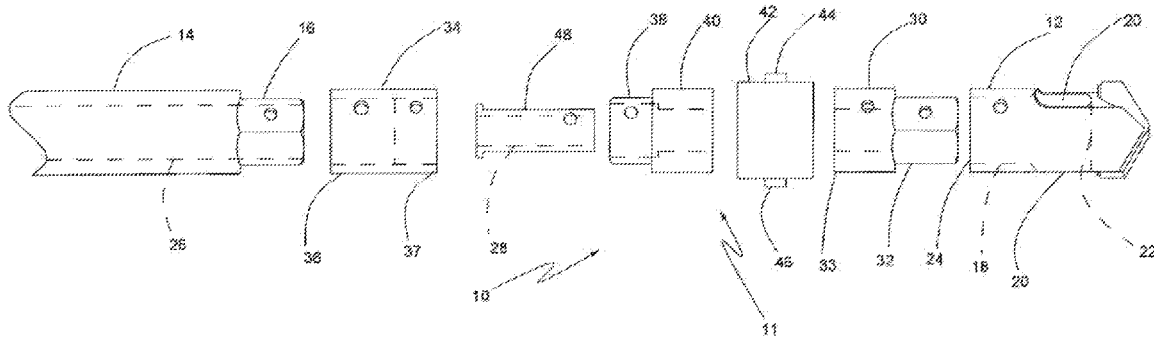

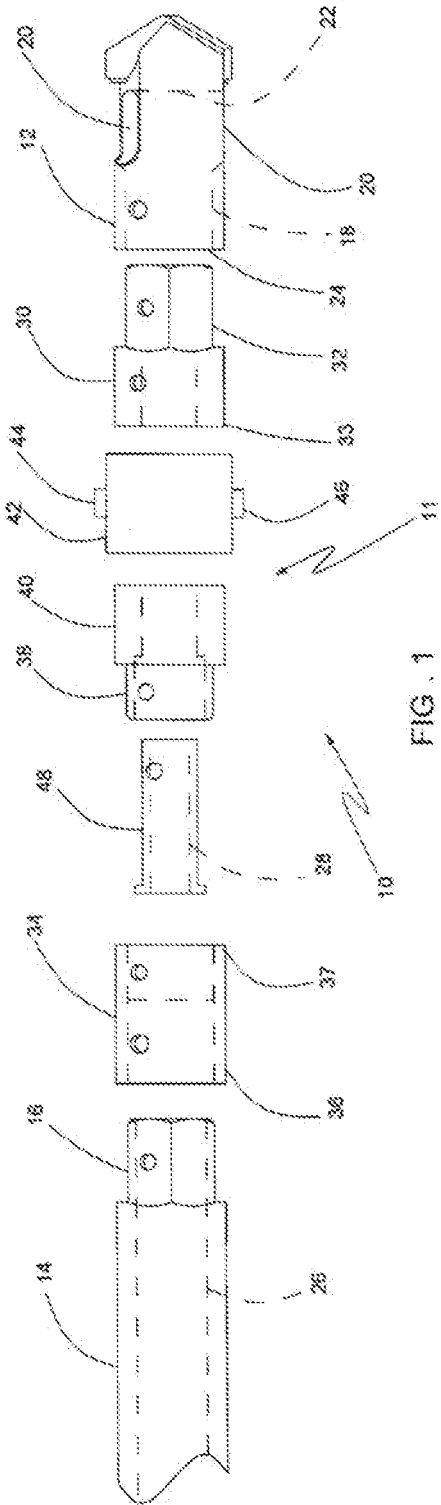

FIG. 1

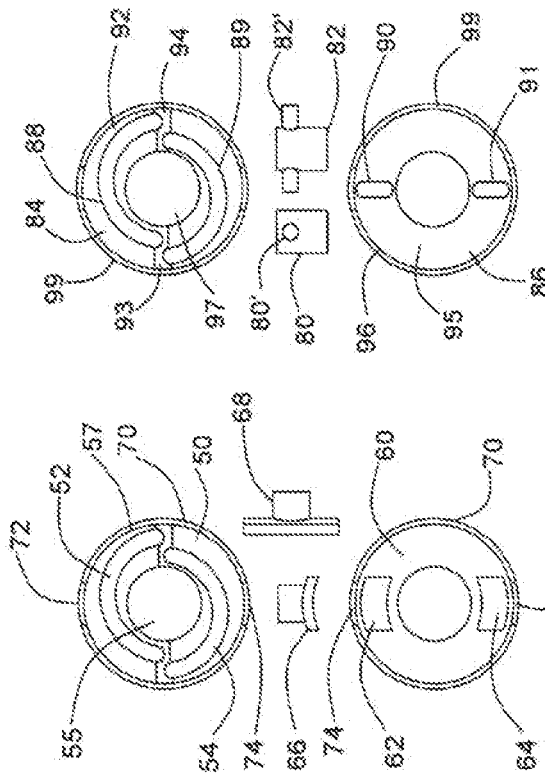

FIG. 3

FIG. 2

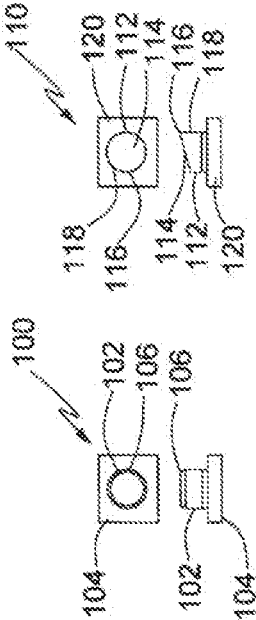

FIG. 4

FIG. 5

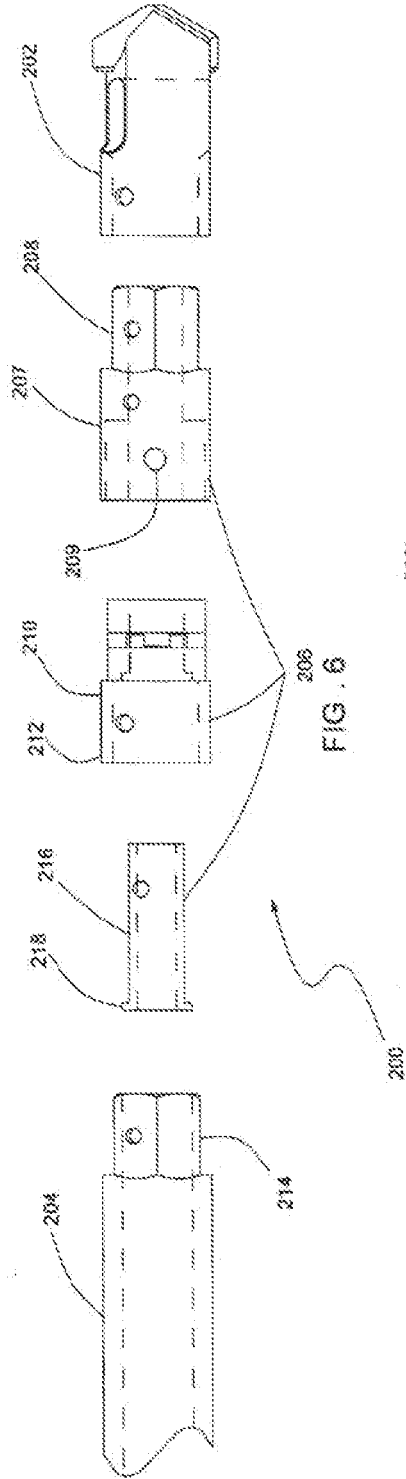

FIG. 6

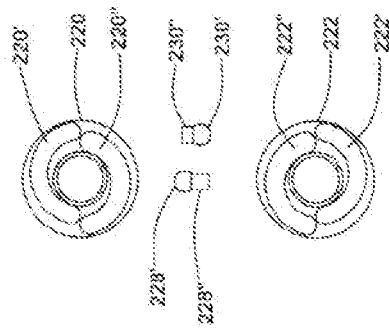

FIG. 6A

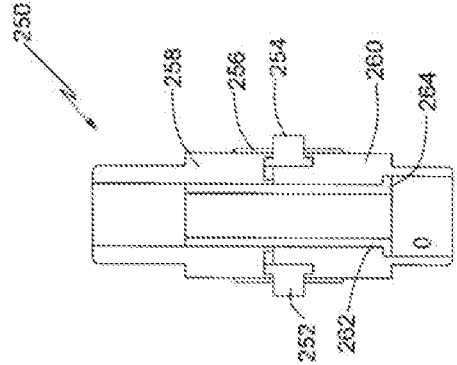

FIG. 7A

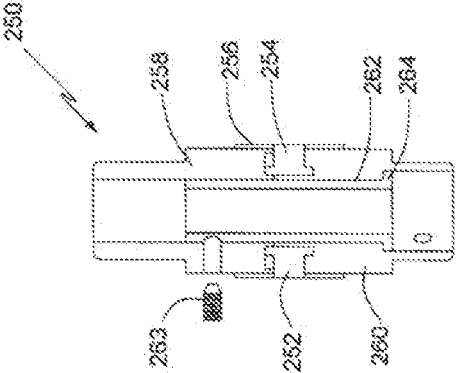

FIG. 7B

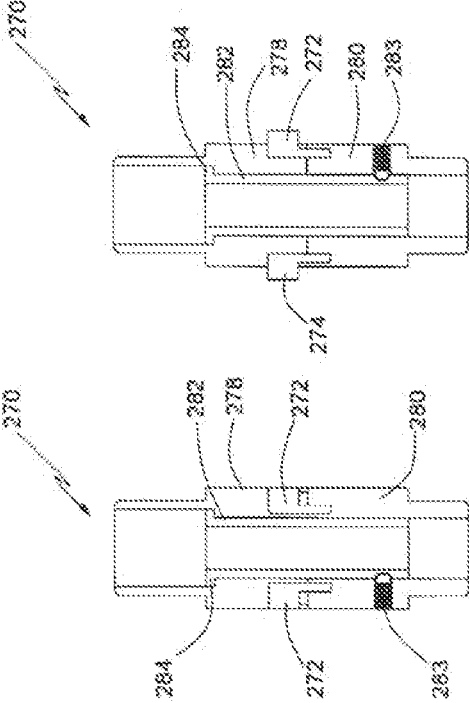

FIG. 8A

FIG. 8B

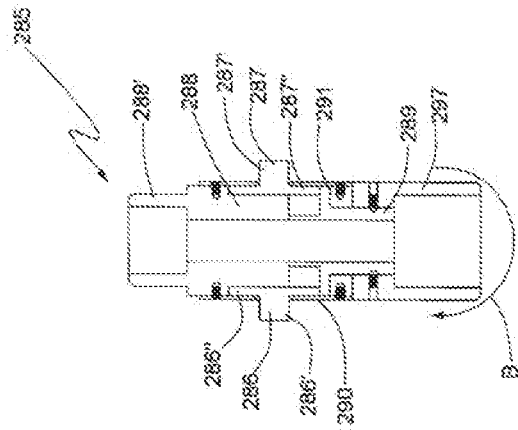

FIG. 9A

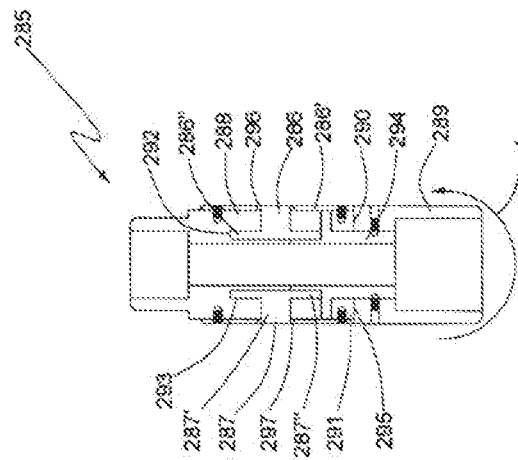

FIG. 9B



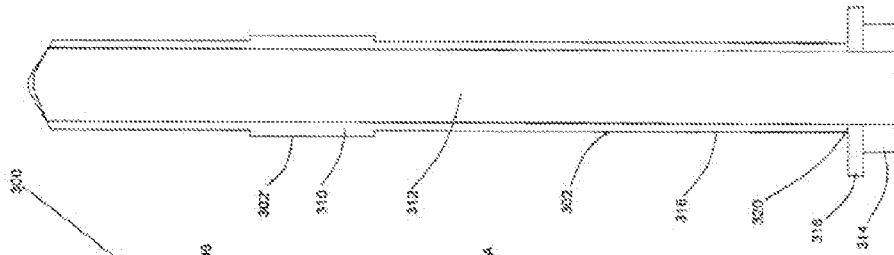

FIG. 100

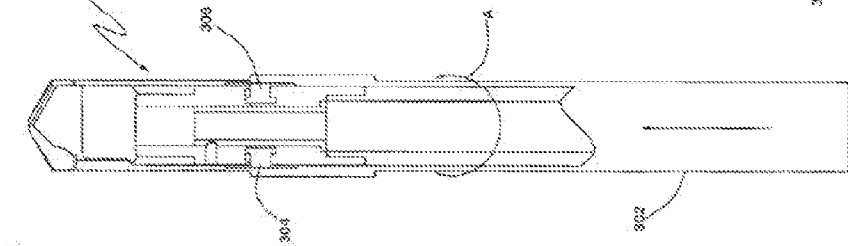

FIG. 10C

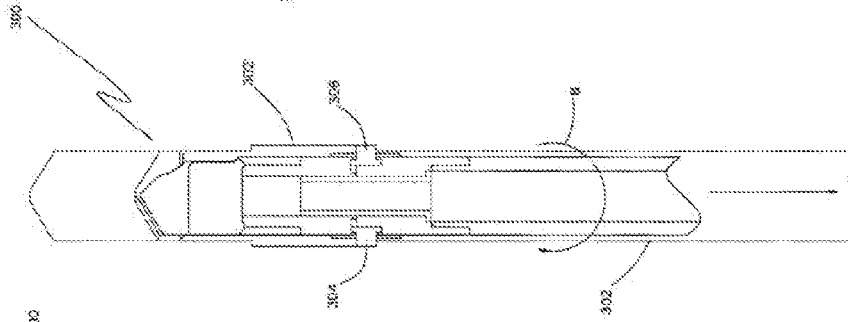

FIG. 10B

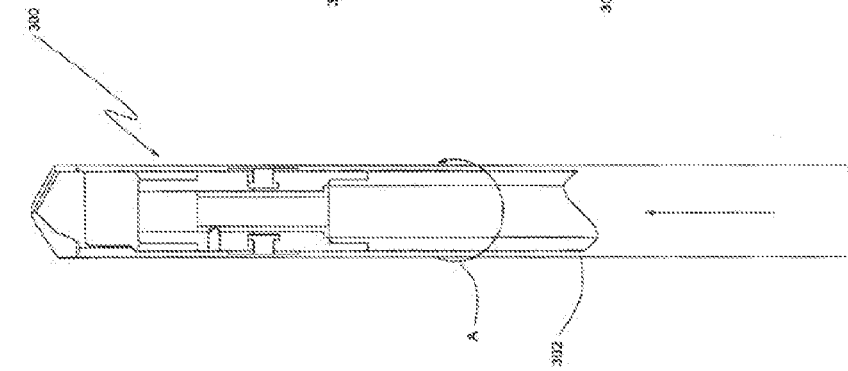

FIG. 10A

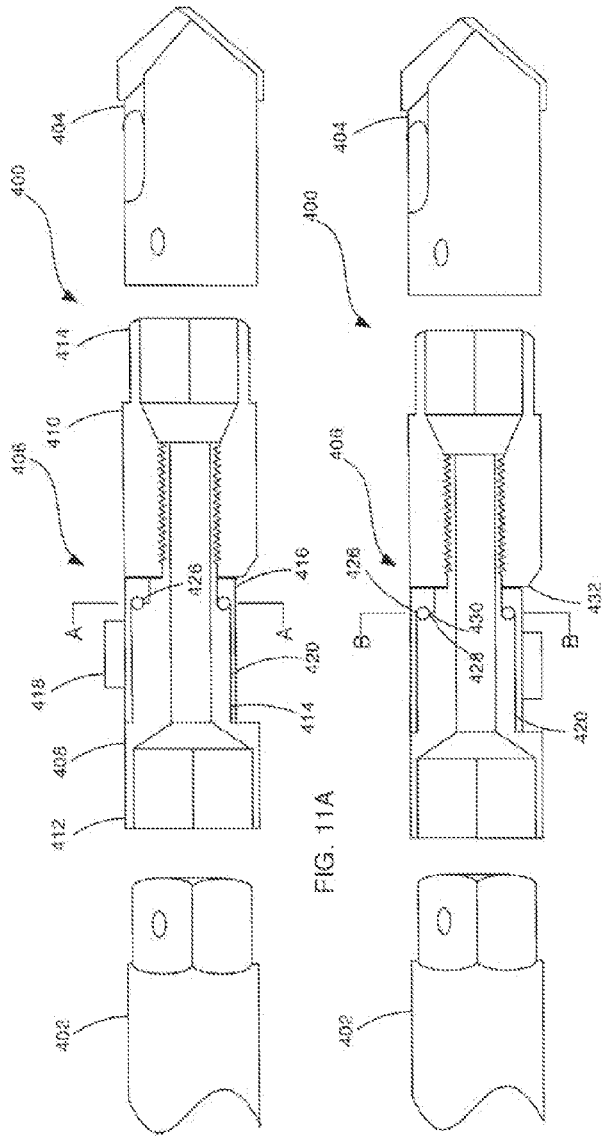

FIG. 11A

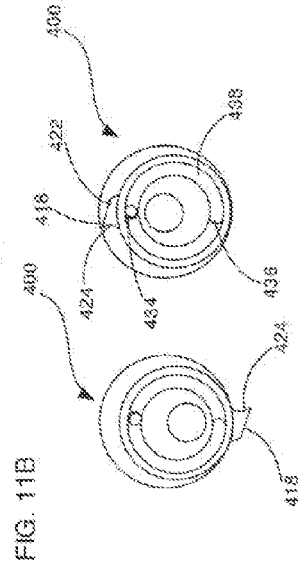

FIG. 11B

FIG. 11D  
(Section B-B)

FIG. 11C  
(Section A-A)

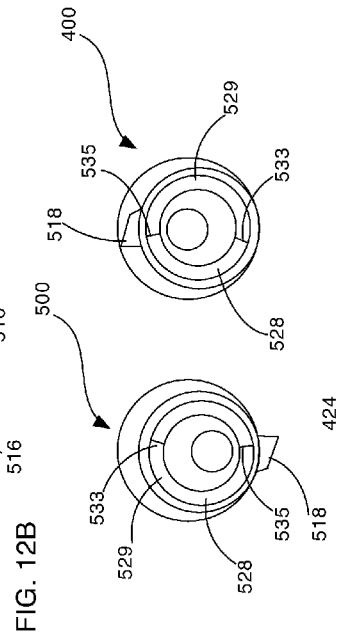
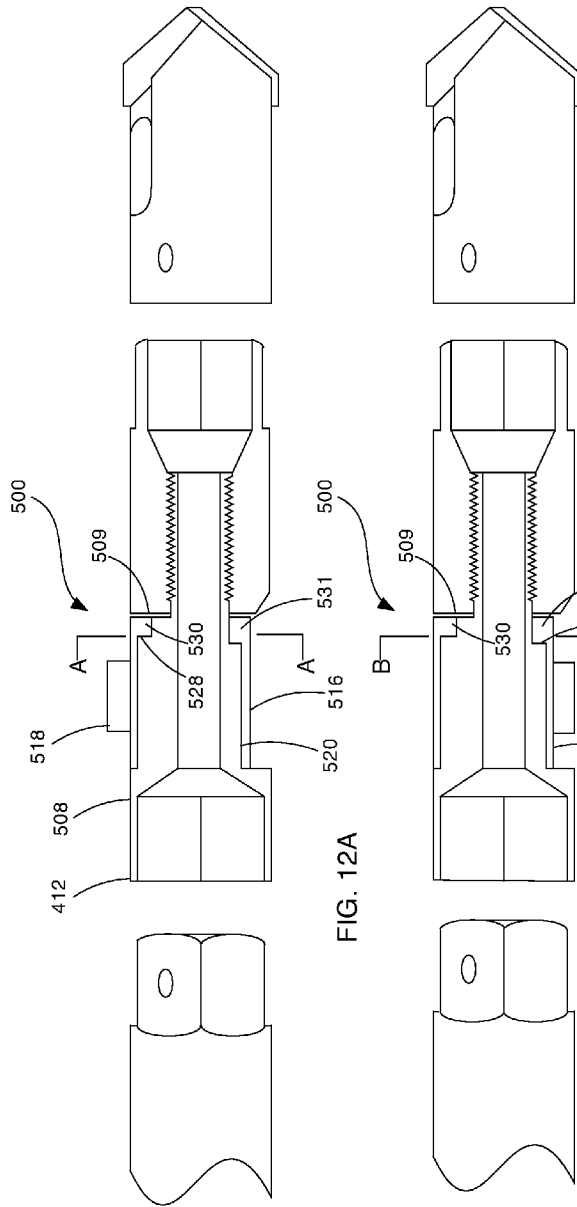
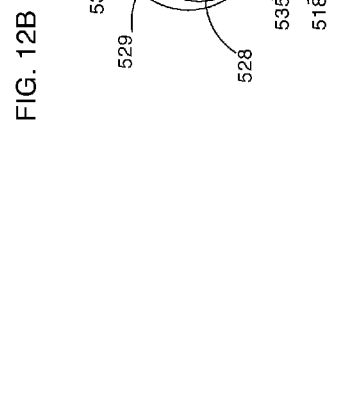

FIG. 12C  
(Section A-A)

FIG. 12D  
(Section B-B)



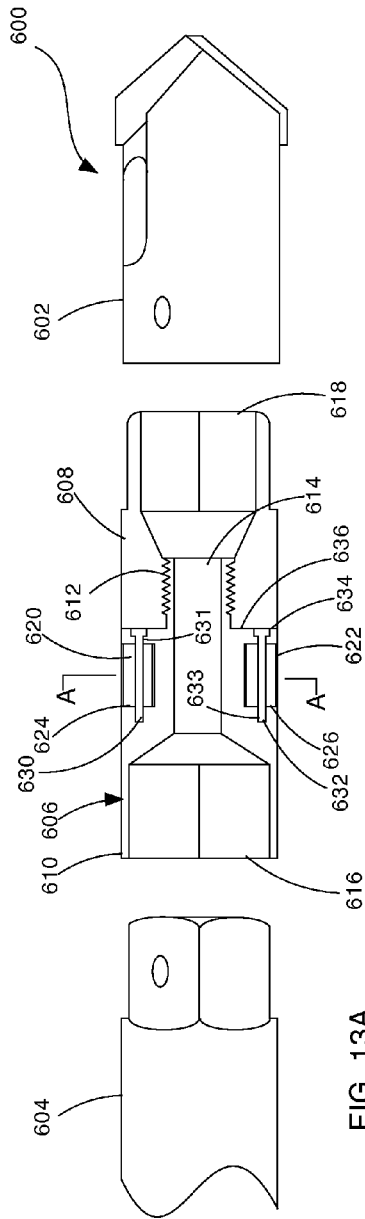

FIG. 13A

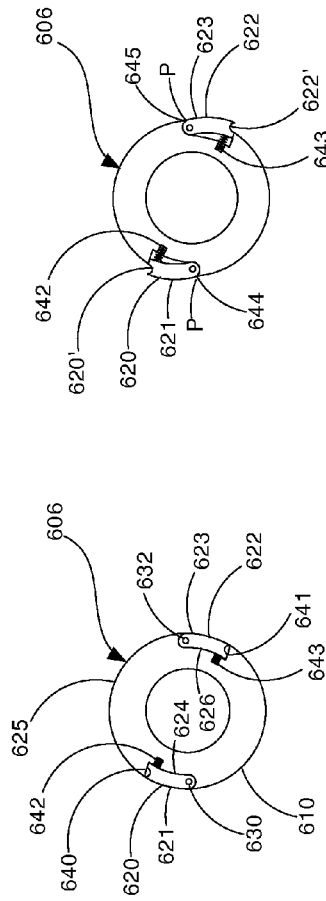

FIG. 13C  
(Section A-A)

FIG. 13B  
(Section A-A)

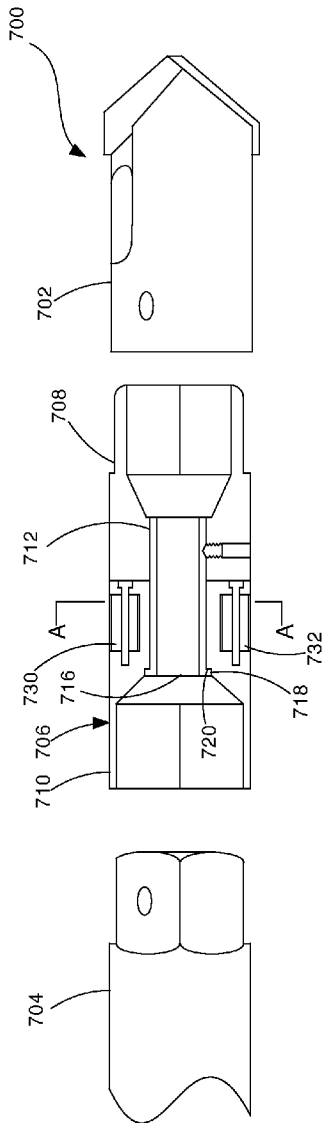

FIG. 14A

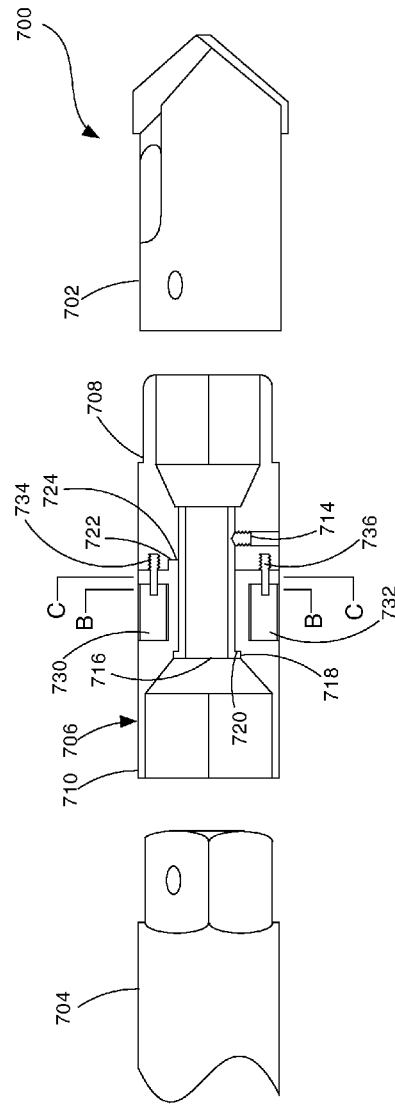

FIG. 14B

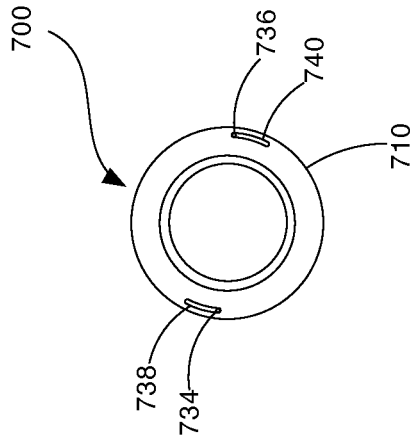

FIG. 14E  
(Section C-C)

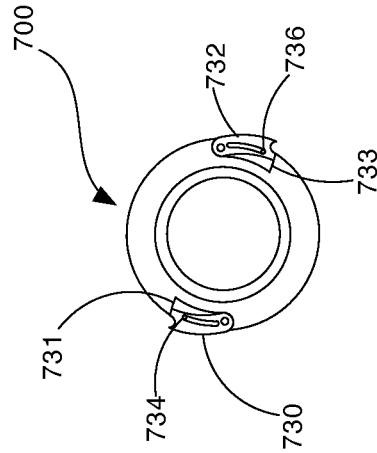

FIG. 14D  
(Section A-A)

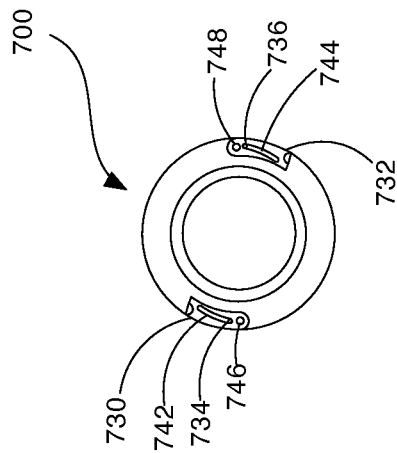

FIG. 14C  
(Section B-B)

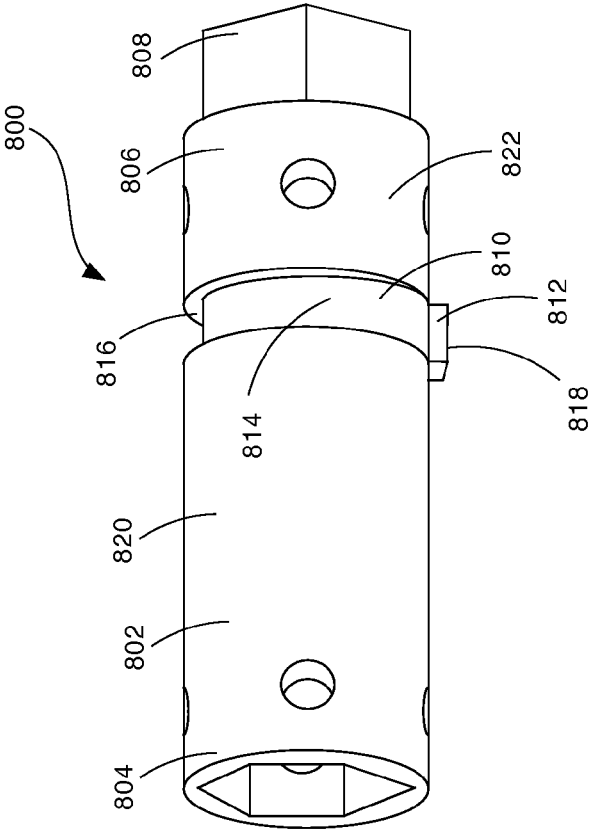

FIG. 15

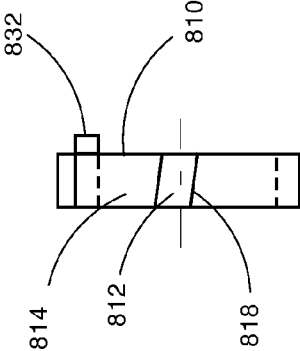

FIG. 16A

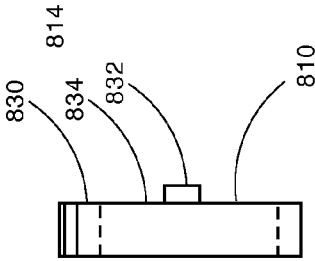

FIG. 16B

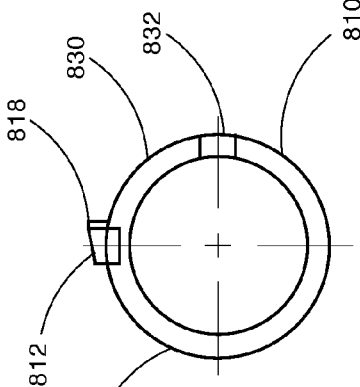

FIG. 16C



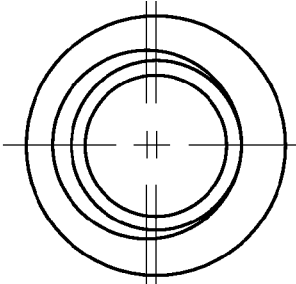

FIG. 17C

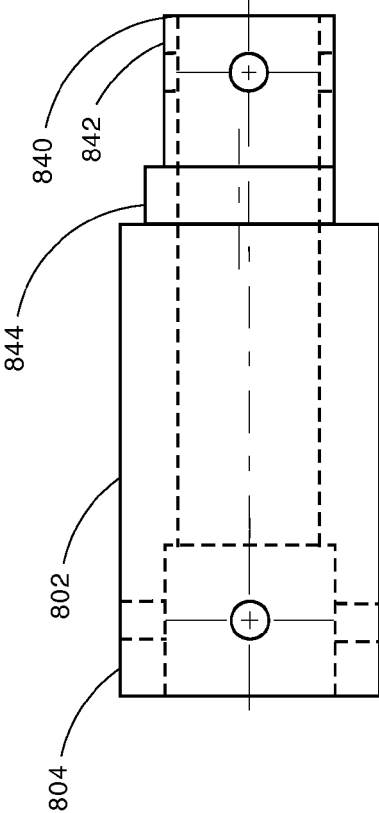

FIG. 17B

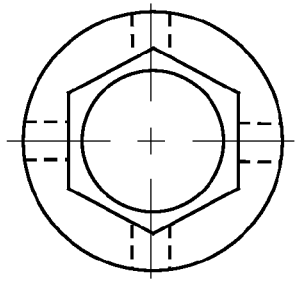

FIG. 17A

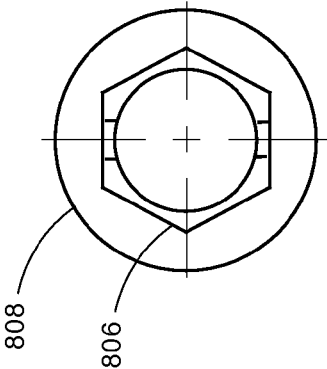

FIG. 18C

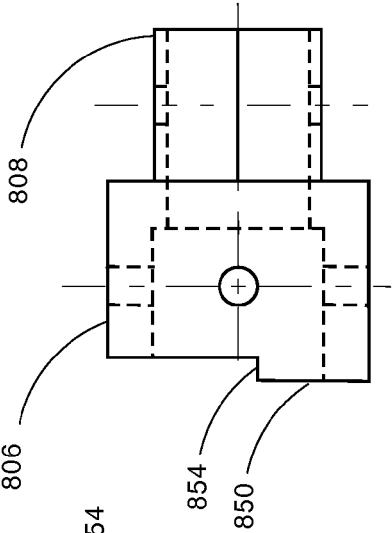

FIG. 18B

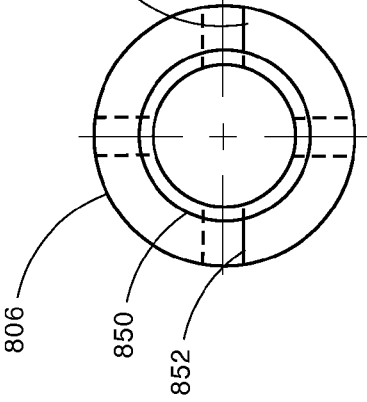

FIG. 18A

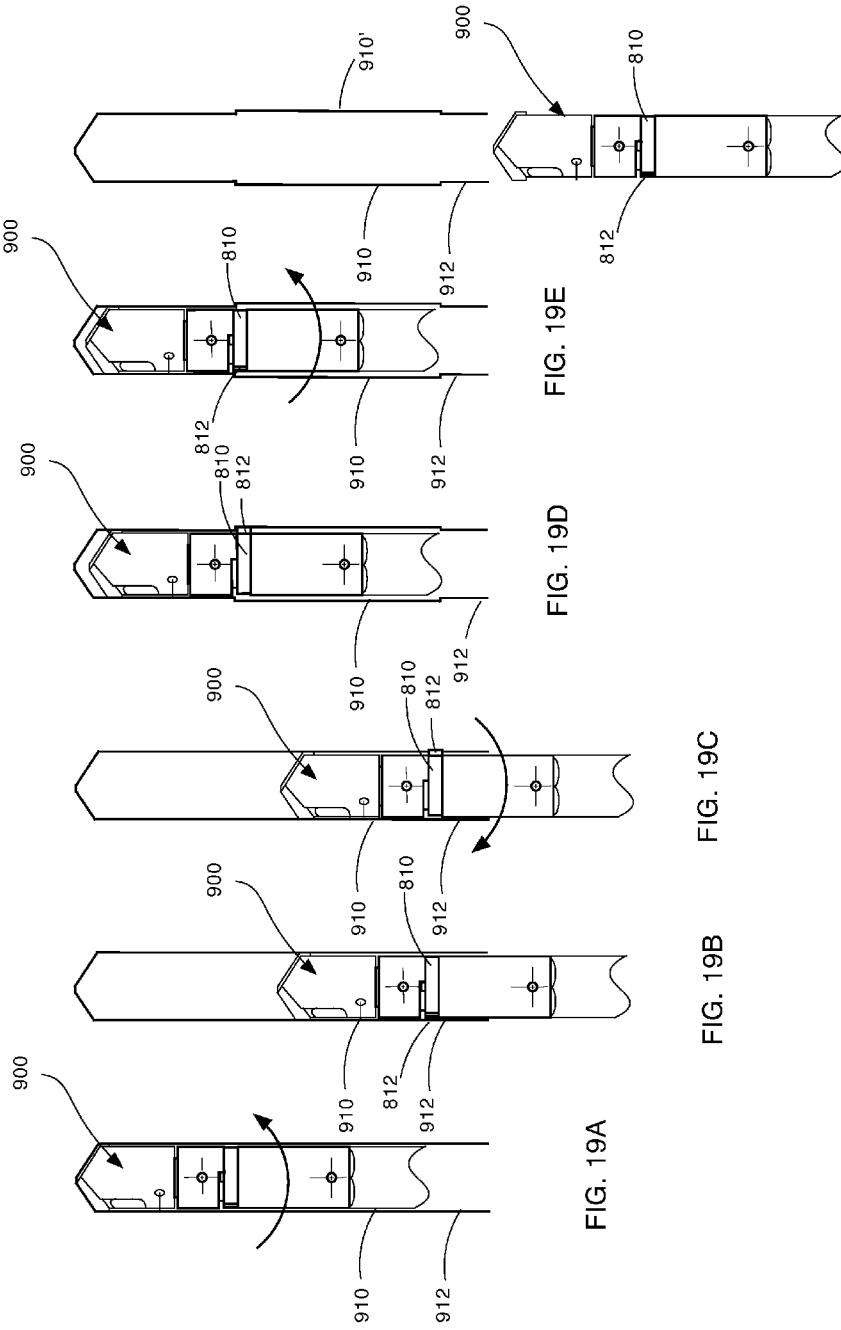

FIG. 19A

FIG. 19B

FIG. 19C

FIG. 19D

FIG. 19E

FIG. 19F

**APPARATUS AND METHOD FOR  
INSTALLING GROUND ANCHORING  
SYSTEMS**

CROSS-REFERENCE TO RELATED  
APPLICATIONS

[0001] This application is a continuation-in-part of U.S. patent application Ser. No. 13/736,538 filed on Jan. 8, 2013, with is a continuation of U.S. patent application Ser. No. 13/351,085 filed on Jan. 16, 2012, now U.S. Pat. No. 8,347,987, which is a continuation-in-part of U.S. patent application Ser. No. 13/233,613, filed on Sep. 15, 2011, now U.S. Pat. No. 8,302,706, which is a continuation-in-part of U.S. patent application Ser. No. 13/178,325, filed on Jul. 7, 2011, now U.S. Pat. No. 8,235,147, the entirety of each of which is incorporated by this reference.

BACKGROUND OF THE INVENTION

[0002] 1. Field of the Invention

[0003] The present invention relates generally to ground anchoring systems, and more specifically, to methods and devices used to drill boreholes in rock strata or other earthen formations for ground anchoring systems.

[0004] 2. State of the Art

[0005] There are various situations where it is critical for safety reasons to maintain the integrity of rock formations or to provide secure anchoring of rock bolts and the like. Such situations may be where earth has been excavated that create a steep inclined wall, tunnelling or in underground mining where the ceiling or roof needs to be secured to prevent a cave-in or even large chunks of rock from falling on workers. In addition, there are situations where the ground is used as an anchoring point to which a cable or other structure in tension must be attached. In such situations, a borehole is drilled and an anchoring system is installed.

[0006] In underground mining, a system of roof bolts is used to secure the roof and walls of a mine shaft so that they are self-supporting. According to U.S. law, many underground coal mine entries must be roof bolted. In order to increase the speed by which the roof is bolted, roof bolting machines have been developed. Currently, such roof bolters include hydraulically driven miner-mounted bolting rigs that can be maneuvered in a mine opening and that includes one or more drilling stations for installing roof bolts.

[0007] A roof bolting machine works by drilling directly into the rock strata with a rock boring drill bit and inserting either conventional bolts, resin roof bolts or cement grouted roof bolts. These machines use bidirectional type drills that are capable of drilling holes into the rock strata of a depth from about four feet to twelve feet. In addition, the machines are used to insert and, in some applications, tighten and tension the roof bolts that are inserted into the predrilled boreholes.

[0008] More modern roof bolting machines are automated to remove the risk of having the operator be exposed to falling rock while the roof bolting procedure is being performed. Such roof bolting machines are operated via remote control from a safer position located away from the unsupported roof area. They use the same technique, however, of drilling a borehole, inserting a resin or cement grout cartridge, inserting a roof bolt and spinning the roof bolt to mix the resin or grout until the resin or grout hardens. The roof bolts may be

installed in an untensioned or tensioned state, depending on the particular bolting method being employed.

[0009] There are primarily two types of roof bolts used in underground mining. In both instances, boreholes are drilled into the roof and/or walls. Long steel rods are inserted into the boreholes and retained in one of two ways. Point anchor bolts or expansion shell bolts are one type of roof bolt. The anchor bolt is typically between about ¾ to 1 inch in diameter and between about 3 and 12 feet in length. An expansion shell is positioned at the end of the bolt that is inserted into the hole. As the bolt is tightened, the expansion shell expands and causes the bolt to be retained within the hole. These types of bolts are considered temporary because corrosion will reduce the life span of such roof bolts. In addition, because they are only secured by the expansion shell, a layer of closely jointed or soft rock at the expansion shell could allow the expansion shell and the roof bolt to move relative to the hole. This can create a dangerous environment, especially in areas where such rock formations are prevalent.

[0010] As such, all underground coal mines in the U.S. use some form of resin or cement grouted roof bolts. One such resin grouted roof bolt is comprised of a length of rebar. The rebar is of a similar size to the anchor bolt previously described, but is not provided with an expansion shell. Rather, after drilling the hole, an elongate tube (cartridge) of resin is inserted into the hole. The rebar is then installed after the resin and spun by the installation drill. This opens the resin cartridge and mixes the resin components. The proximal end of the rebar includes a head that engages a roof plate when fully inserted into the borehole. For tensioning applications, the rebar may include an exposed threaded end for receiving a threaded nut that can be tightened against a roof plate, which in turn is pressed against the roof thus holding the rock strata together. Such tensioning applications usually require a point anchor at the distal end of the rebar. In such applications, an expansion shell system may be used in combination with a resin or cement grout to provide a point anchor at the distal end and to allow tensioning of the roof bolt. In other untensioned applications, the rebar is simply inserted with the resin or cement grout and spun for a few seconds. The resin or grout is allowed to cure with the rebar inserted. Such resin or cement grouted rebar is considered a more permanent form of roof support with a potential lifespan in excess of twenty years, since the resin or cement grout help prevent corrosion of the rebar. Long sections of cable have also been employed in place of conventional roof bolts. They are installed in a similar manner to conventional resin or cement grouted roof bolts, but may have significantly longer lengths. Even with the resin or cement hardened around the roof bolt, in some underground mines where the rock strata is unstable, or mostly comprised of closely jointed rock or soft rock, the roof bolt can be relatively easily dislodged from the borehole in which it has been inserted. This may occur even when the bolt is tensioned during the installation process or later and without warning when the result could create a potentially serious safety threat. In such environments, current methods of roof bolt installation do not provide any way to increase the load bearing capability of each roof bolt. In other words, if a roof bolt is imbedded in soft or highly fragmented rock formations, there may be no way to know if the roof bolt is going to hold and there is nothing that can help prevent the roof bolt from failing.

[0011] As such there is a significant need in the art to provide a method for installing ground anchors, such as roof

bolts, that ensures that the ground anchor will be adequately secured to the ground even in conditions of closely jointed or soft rock. There is also a need to provide such a method for installing ground anchors that does not add any significant amount of time to the anchor installation process. In addition, there is a need in the art to provide a method for installing a ground anchor that is easy to follow and consistently produces the desired result of ensuring that the ground anchor will properly perform even in ground conditions that are not conducive for such anchoring system installations.

#### SUMMARY OF THE INVENTION

**[0012]** Accordingly, the present invention provides an apparatus and method of using the apparatus to drill holes into earthen formations that creates a wider diameter down hole than the diameter of the hole at the point of entry. In other words, the apparatus of the present invention is capable of creating a hole having two different diameters, with a wider diameter portion being down hole of a narrower diameter portion. The apparatus is configured to work with conventional drill bits used for drilling rock formations, such as when installing rock or roof bolts in underground mining situations, but could be adapted for other situations, such as when anchoring tension cables to rock formations.

**[0013]** In one embodiment an apparatus for forming a borehole in an earthen formation is comprised of a drill bit having a distal cutting end and a proximal end configured for coupling. A side cutting apparatus is comprised of a first end configured for coupling to the drill bit and a second end configured for coupling to a drill stem. A first cam structure has at least one groove formed therein with the groove being laterally radially offset relative to the first cam structure. At least one cutting element having a base portion is at least partially disposed within the groove and includes a cutting portion depending from the base portion that radially extends from the first cam structure. A second cam structure is positioned adjacent to the first cam structure for retaining the at least one cutting element within the groove. An inner sleeve is rotatably coupled to one of the first cam structure and the second cam structure and fixedly coupled to the other of the first cam structure and the second cam structure. Rotation of the drilling stem in a first direction causes the at least one cutting element to be in a first retracted position relative to the outer sleeve and rotation of the drilling stem in a second direction causes the first cam structure to rotate relative to the second cam structure to thereby force the at least one cutting element to move along the groove to a second extended position.

**[0014]** In another embodiment, the first cam assembly includes a pair of grooves, each groove being laterally radially offset relative to the first cam structure and in an opposite direction to the other groove.

**[0015]** In another embodiment, the base portion of the cutting element is comprised of one of a pin, an arcuate plate and a semispherical ball.

**[0016]** In still another embodiment, the second cam structure defines at least one recess in a face thereof that faces the first cam structure. At least a portion of the base portion of the cutting element is positioned within the recess. The recess has a width substantially similar to a width of the base portion inserted therein and a length sufficient to allow the base portion to translate within the recess as the base portion moves along the groove.

**[0017]** In yet another embodiment, an outer sleeve is positioned over an interface between the first cam structure and the second cam structure and has at least one aperture formed in a sidewall thereof. The cutting portion of the cutting element extends through the aperture at least when in the second extended position.

**[0018]** In another embodiment, the first and second cam structures are in a fixed relation to each other. The second cam structure includes a corresponding groove to the groove in the first cam structure. The outer sleeve is fixedly coupled relative to one of the first cam structure and the second cam structure so as to rotate therewith.

**[0019]** In still another embodiment, the outer sleeve is integrally formed with the first cam structure and the second cam structure fits at least partially within the outer sleeve.

**[0020]** In another embodiment, an apparatus for forming a borehole in an earthen formation comprises a side cutting assembly having a first body portion with a first end configured for coupling to a drill bit and a central vacuum bore and a second body portion coupled to the first body portion having a second end configured for coupling to a drill stem. Either the first body portion or second body portion has a nonconcentric cylindrical portion with a diameter that is less than a diameter of the first body portion proximate the first end thereof. A sleeve disposed on the nonconcentric cylindrical portion is partially rotatable relative thereto between a first position and a second position. At least one cutting element is disposed on the outer surface of the sleeve so that when the sleeve is in the first position, the at least one cutting element is in a retracted position and when the sleeve is in the second position the at least one cutting element is in an extended position for cutting a sidewall of a borehole to enlarge a diameter of the borehole while the at least one cutting element is in the extended position.

**[0021]** In yet another embodiment, the at least one cutting element has a leading edge that is spaced radially farther from the longitudinal axis of the first body than a trailing edge of the at least one cutting element to cause the at least one cutting element to engage the sidewall of the borehole when the drill bit is reversed to cause the sleeve to rotate relative to the first body from the first position to the second position.

**[0022]** In another embodiment, the cutting element engages the sidewall of the borehole when the drill bit is reversed to cause the sleeve to rotate relative to the first body from the first position to the second position and to force the at least one cutting element into further engagement with the sidewall of the borehole. The sleeve is freely rotatable approximately one hundred eighty degrees between the first position and the second position.

**[0023]** In another embodiment, the apparatus includes a first semicircular groove in an inner lateral surface of the sleeve and a second semicircular groove in an outer surface of the first body. A spherical bearing is disposed within the first and second semicircular grooves whereby rotation of the sleeve relative to the first body is limited by engagement of the spherical bearing with respective ends of the first and second semicircular grooves.

**[0024]** In still another embodiment, the apparatus includes a groove in an inner surface of the sleeve and a protrusion extending from an outer surface of the body whereby rotation of the sleeve relative to the body is limited by engagement of the protrusion with ends of the groove.

**[0025]** The present invention also includes a method for forming a borehole in an earthen formation comprising pro-

viding a drill bit assembly in accordance with the principles of the present invention. First, the drill bit assembly is rotated in a first direction to drill a borehole in an earthen formation with the at least one cutting element in a first retracted position. Next, the drill bit assembly is rotated in a second direction to rotate the first cam structure relative to the second cam structure, thereby forcing the cutting element to move along the groove to a second extended position. As the drill bit assembly is rotating in the second direction, the drill bit is retracted a certain distance from the borehole to form an enlarged borehole portion in a down hole location. Rotation of the drill bit assembly back in the first direction causes the cutting element to retract to the first retracted position. The drill bit assembly can then be removed from the borehole. This creates an enlarged diameter portion in the borehole at a down hole location.

**[0026]** In another embodiment, the invention includes a method for forming a borehole in an earthen formation for an anchoring system that comprises rotating a drill bit in a first direction, drilling a borehole having a first diameter into an earthen formation to a first down hole position of a depth sufficient to receive a portion of an anchoring system, maintaining the drill bit in the first down hole position while rotating the drill bit in a second direction opposite to the first direction to cause a side cutting element to engage a sidewall of the borehole proximate the first down hole position, moving the drill bit to a second down hole position that is closer to an opening of the borehole than the first down hole position while rotating the drill bit in the second direction to cause the side cutting element to increase the first diameter of the borehole to a second diameter between approximately the first down hole position and the second down hole position, reversing the rotation of the drill bit back to the first direction to cause the side cutting element to disengage the sidewall of the borehole, and removing the drill bit from the borehole.

**[0027]** In yet another embodiment, the invention includes a method for forming a borehole in an earthen formation for an anchoring system that comprises rotating a drill bit in a first direction to drill a borehole having a first diameter into an earthen formation to a first down hole position of a depth sufficient to receive a portion of an anchoring system. The drill bit is then retracted a distance within the borehole to a second down hole position spaced from the first down hole position with the side cutting element of the drill bit of the present invention positioned within the borehole. With the drill bit located in the second down hole position, the drill bit is rotated in a second direction opposite to the first direction to cause a side cutting element to engage a sidewall of the borehole proximate the second down hole position. The drill bit is then moved from the second down hole position toward the first down hole position causing the side cutting element to remove additional material from the sidewall of the borehole, thus enlarging the diameter of the borehole as the bit is moved toward the first down hole position. When the drill bit moves a sufficient distance to enlarge a desired length of the borehole, the drill bit is rotated back to the first direction to cause the side cutting element to retract and thus disengage the sidewall of the borehole so that the drill bit can be removed from the borehole.

#### BRIEF DESCRIPTION OF THE DRAWINGS

**[0028]** The foregoing summary, as well as the following detailed description of the illustrated embodiments is better understood when read in conjunction with the appended

drawings. For the purpose of illustrating the invention, there is shown in the drawings several exemplary embodiments which illustrate what is currently considered to be the best mode for carrying out the invention, it being understood, however, that the invention is not limited to the specific methods and instruments disclosed. In the drawings:

**[0029]** FIG. 1 is an exploded side view of a first embodiment of a drill bit and a drill bit adapter in accordance with the principles of the present invention.

**[0030]** FIG. 2 is a top and bottom view, respectively, of one embodiment of a pair of cam components in accordance with the principles of the present invention.

**[0031]** FIG. 3 is a top and bottom view, respectively, of another embodiment of a pair of cam components in accordance with the principles of the present invention.

**[0032]** FIG. 4 is a side and front view of one embodiment of a cutting element in accordance with the principles of the present invention.

**[0033]** FIG. 5 is a side and front view of another embodiment of a cutting element in accordance with the principles of the present invention.

**[0034]** FIG. 6 is an exploded side view of a third embodiment of a drill bit and a drill bit adapter in accordance with the principles of the present invention.

**[0035]** FIG. 6A is a top view of the components of a cam mechanism illustrated in FIG. 6.

**[0036]** FIGS. 7A and 7B are cross-sectional side views of yet another embodiment of a side-cutting adapter in accordance with the principles of the present invention.

**[0037]** FIGS. 8A and 8B are cross-sectional side views of yet another embodiment of a side-cutting adapter in accordance with the principles of the present invention.

**[0038]** FIGS. 9A and 9B are cross-sectional side views of still another embodiment of a side-cutting adapter in accordance with the principles of the present invention.

**[0039]** FIGS. 10A, 10B, 10C and 10D are cross-sectional side views of a drill string in accordance with the principles of the present invention in various stages of cutting a borehole according to the methods of the present invention.

**[0040]** FIGS. 11A, 11B, 11C and 11D are cross-sectional side views of another embodiment of a drill bit and a drill bit adapter in accordance with the principles of the present invention.

**[0041]** FIGS. 12A, 12B, 12C and 12D are cross-sectional side views of yet another embodiment of a drill bit and a drill bit adapter in accordance with the principles of the present invention.

**[0042]** FIGS. 13A, 13B, and 13C are cross-sectional views of still another embodiment of a drill bit and a drill bit adapter in accordance with the principles of the present invention.

**[0043]** FIGS. 14A, 14B, 14C, 14D and 14E are cross-sectional views of yet another embodiment of a drill bit and a drill bit adapter in accordance with the principles of the present invention.

**[0044]** FIG. 15 is a perspective view of another embodiment of a drill bit adapter in accordance with the principles of the present invention.

**[0045]** FIGS. 16A, 16B and 16C are side and end views of a cutting ring for the drill bit adapter shown in FIG. 15.

**[0046]** FIGS. 17A, 17B and 17C are side and end views of a first body portion of the drill bit adapter shown in FIG. 15.

**[0047]** FIGS. 18A, 18B and 18C are side and end views of a second body portion of the drill bit adapter shown in FIG. 15.

[0048] FIGS. 19A, 19B, 19C, 19D, 19E and 19F are side views of a drill string in accordance with the principles of the present invention in various stages of cutting a borehole according to the methods of the present invention.

#### DETAILED DESCRIPTION OF THE ILLUSTRATED EMBODIMENTS

[0049] FIG. 1 is side view of a first embodiment of a drill assembly, generally indicated at 10, configured for enlarging a borehole diameter in a down hole position according to the principles of the present invention. The drill assembly 10 is configured to work with a conventional rock drilling bit 12 and drill stem 14. In a conventional configuration, the drill bit 12 is directly coupled to the drill rod or stem 14 (commonly referred to as the "drill steel") with the hexagonal end 16 of the drill stem inserted into the corresponding hexagonal opening in the drill bit 12. The drill bit 12 is provided with transversely extending side vents 20 that extends transversely through a central portion 22 of the drill bit 12 and are in fluid communication with a longitudinal bore 18 that extends from an open proximal end 24 of the drill bit 12 to the side vents 20. The drill stem 14 also includes a longitudinally extending bore 26 that when coupled to the bit 12 provides a continuous duct through which debris from a drilling process can be vacuum pulled through the vent 20 along the bore 26 and to a collection bin in the drilling machine (not shown) in order to reduce the amount of drilling dust that exits the borehole being drilled with the bit 12.

[0050] The drill assembly 10 is configured with a longitudinally extending bore 28 that when the parts are assembled that extends from the bit 12 through the drill stem 14 so as to allow the aforementioned debris to be drawn through the drill assembly 10 during the drilling process as previously described. The drill assembly 10 includes a side cutter assembly 11 that includes a first cam component 30 configured for attachment to the drill bit 12. Thus, the distal end 32 of the component 30 is configured to fit within the proximal end 24 of the bit 22. The proximal end 33 is provided with a first set of cam features therein. A drill stem attachment component 34 has a proximal end 36 configured for attachment to the hexagonal end of the drill stem 16 and a distal end 37 configured for attachment to a proximal end 38 of a second cam component 40. The first and second cam components form camming surfaces (not visible). An exterior sleeve 42 that holds a pair of laterally extendable cutters 44 and 46 is configured to fit over the first and second cam components 30 and 40. An internal sleeve 48 is configured to fit within and abut against the second cam component and be fixedly coupled to the first cam component 30. This allows the first cam component 30 to rotate to a certain degree relative to the second cam component 40. In other words, the second cam component can swivel about the internal sleeve 48 in either direction to a limited degree. In operation, as will be described in more detail herein, engagement of the cam features of the cam component 30 and 40 along with relative rotation of the first cam component 30 relative to the second cam component 40 will cause the cutters 44 and 46 to extend or retract laterally relative to the sleeve 42 depending on the direction of rotation of the bit 12 relative to the stem 14.

[0051] As will be discussed throughout, the cam components and cutters may have various configurations. For example, as shown in FIG. 2, a first cam component 50 is provided with first and second cam grooves 52 and 54. The cam grooves 52 and 54 are oppositely oriented on opposite

halves of the cam component 50. The cam grooves are radially offset so that each groove 52 and 54 has a beginning point and end point that are at different radial positions with each groove 52 and 54 having a radius along the center of the groove that is approximately equal to a radius of the cam component 50 at a position midway between the central aperture 55 and the outer circumferential surface 57. In other words, the mean radius of each groove is approximately equal to the radius at the midpoint between the aperture 55 and the outer surface 57. In addition, each groove 52 and 54 has a semi-circular contour. Each groove 52 and 54 is transversely offset relative to a diameter of the cam component and in opposite directions. As such, they are not mirror images of one another, but rather 180 degree rotations of each other. In the second cam component 60, first and second, oppositely oriented recesses 62 and 64 are formed therein. First and second cutters 66 and 68, each include a base portion 66' and 68' and a cutter portion 66" and 68" extending therefrom. The base portions 66' and 68' are configured with one side to fit in a respective cam groove and the other side to fit within a respective one of the recess 62 and 64 when the first and second cam components 50 and 60 are brought together. The sleeve 70 that surrounds the cam components 50 and 60 is provided with apertures 72 and 74 sized to receive a respective one of the cutters 66 and 68. The outer sleeve 70 is configured to be fixedly coupled to the cam component 60, but rotatable relative to the cam component 50. As the sleeve 70 rotates, the engagement of the bases 66' and 68' of the cutters 66 and 68 with the grooves 52 and 54, respectively, causes the cutters to be laterally displaced relative to the sleeve 70 as the bases 66' and 68' slide along the grooves 52 and 54 to cause the cutters 66 and 68 to protrude from the sleeve 70 or retract within the sleeve 70. In so doing, the base portions 66' and 68' of the cutters 66 and 68 slide linearly within the recesses 62 and 64 that are sized to fit the base portions 66' and 68'. It should be noted that while the various embodiments shown and described herein include a pair of cam grooves and a corresponding pair of cutters arranged directly transverse to one another, the side cutting apparatus of the present invention could be formed with a single groove and a single side cutter or multiple cutters arranged in multiple cam assemblies that are stacked one on top of the other in accordance with the principles of the present invention.

[0052] FIG. 3 illustrates a similar configuration to that of FIG. 2 with differently configured side cutters 80 and 82 and cam components 84 and 86. The cutters 80 and 82 are provided with laterally extending cylindrical arms or pins 80' and 82' that are sized to engage a respective cam groove 88 or 89 on one side and recesses 90 and 91 formed in cam component 86 on the other side. The face 92 of the cam component 84 is provided with raised portions 93 and 94 to abut against the surface 95 of cam component 86. This creates lateral stability between the components 84 and 86 as they rotate and slide relative to each other in order to cause lateral displacement of the cutting elements 80 and 82 relative to the sleeve 96 as described with reference to FIG. 2. Because of the engagement of the pins 80' and 82' with a respective groove 88 and 89, the cam components 84 and 86 can rotate relative to each other a limited amount. In this embodiment, the relative rotation is slightly less than 90 degrees. However, over that angular rotation, the pins 80' and 82' can move from near the center aperture 97 to the outside edge of the cam component 84. This will cause lateral displacement of the cutters 80 and 82 relative to the sleeve 99 of the distance between the radius of the

component **84** to the center of the groove **88** at its point nearest the center of the component **84** and the radius of the component **84** to the center of the groove **88** at its point farthest from the center of the component **84**. Given that the diameter of the component **88** may be only 1.25 inches (3.2 mm) for a roof bolt application, the lateral displacement of each cutter **80** and **82** may be about 2 to 4 mm, resulting in an increase in diameter of the borehole of 4 to 8 mm.

[0053] As illustrated in FIGS. 4 and 5, the individual cutting elements may have different configurations and may be in a form similar to diamond cutting elements used on earth boring drill bits, such as rotary drag bits. The cutting element **100** is predominantly comprised of a diamond cutting structure **102** attached to a base structure **104**. The leading or exposed edge **106** of the diamond cutting structure is beveled to increase the integrity of the cutting structure and to help prevent breakage of the cutting element at this edge. The cutting element **110** shown in FIG. 5 is similarly configured with a diamond cutting structure **112**, but the cutting structure includes a tapered top surface **114** to provide a sharpened leading edge **116** defining an acute angle between the surface **114** and the front side **118** of the cutting structure **112**. Again, the cutting structure is attached to the base **120**. When positioned within a cutting apparatus according to the principles of the present invention, the leading edge **116** is oriented so that when the cutting structure **112** is extended and positioned for cutting, the leading edge **116** is oriented toward the direction of rotation so that the cutting is achieved by this sharpened leading edge **116**. The cutting structure **112** is bonded to the base **120** by methods known in the art. The cutting structure **112** may also be formed from tungsten carbide or other materials known in the art for their cutting properties.

[0054] FIG. 6 illustrates another embodiment of an earth boring drill assembly **200** in accordance with the principles of the present invention. The drill assembly **200** includes a standard drill bit **202** and standard drill stem **204**. Interposed between the drill bit **202** and drill stem **204** is a selectively actuated bore enlarging cutting device **206** that forms an adapter between the drill bit **202** and the drill stem **204**. The cutting device **206** is comprised of an outer housing component **207** configured at one end **208** for attachment to the drill bit **202**, a cam assembly **210** having one end **212** configured for mating with the distal end **214** of the drill stem **204** and an inner sleeve **216** having a retaining rim **218** at one end to abut against an inside surface of the cam assembly **210**. The inner sleeve **216** has a length sufficient to pass through the cam assembly **210** and be attached to the outer housing **207**. The cam assembly can thus freely rotate a limited degree within the outer housing **207** in either direction.

[0055] As shown in FIG. 6A, the cam assembly **210** is comprised of a first cam member **220** and a second cam member **222** that are configured with corresponding cam grooves **220'**, **220"**, **222'** and **222"**. The center portions **224** and **226** of each cam member **220** and **222** are provided with respective mating raised and recessed surfaces so that when the two cam members **220** and **222** are brought together, their relative rotational orientation is maintained. In this way, groove **222'** will be positioned directly above groove **220'** and groove **222"** will be positioned directly above groove **220"**. Thus, the respective grooves work in tandem to guide a cutting element therein. The cutting elements **228** and **230** are each comprised of a semispherical base portion **228'** and **230'** and an attached cylindrical cutting element **228"** and **230"**. The cutting elements each protrude through an aperture **209**

in the outer sleeve member **207**. As the sleeve **207** rotates relative to the cam assembly **210**, the base portions **228'** and **230'** slide or roll along their respective groove set **220'** and **220"** or **222'** and **222"**. This causes the cutting portions **228"** and **230"** to extend or retract relative to the sleeve **207**.

[0056] As shown in FIGS. 7A and 7B, a side cutting bit adapter, generally indicated at **250**, is capable of extending and retracting laterally extendable side cutters **252** and **254** from a retracted position shown in FIG. 7A where the outermost surface of each side cutter **252** and **254** is substantially flush with an outer sleeve **256** to a second extended position shown in FIG. 7B where at least a portion of each cutter **252** and **254** extend outwardly from the sleeve **256**. This lateral movement of the side cutters **252** and **254** is actuated by rotational movement of the upper cam member **258** relative to the lower cam member **260**. The upper cam member **258** is rigidly mounted to the inner sleeve **262**, as with a setscrew **263** while the lower cam member **260** abuts against the proximal end **264** of the sleeve **262** but can freely rotate relative to the inner sleeve **262** and the upper cam member **258**. This allows the upper cam member **258** to be rotated relative to the lower cam member **260** from a first position in which the cutting elements **252** and **254** are in a retracted state to a second position, as shown in FIG. 7B, in which the cutting elements **252** and **254** are fully extended. Reversing the direction of the drill to which the adapter **250** is attached will reverse the movement of the cutting elements **252** and **254**. As the lower cam member **260** is rotated in a clockwise direction, the base portions of the cutting elements **252** and **254** that engage corresponding grooves in the lower cam member slide along the grooves. The upper cam member **258** is provided with recesses that allow for lateral movement of the cutting elements **252** and **254** relative thereto, but that prevents any substantial movement of the cutting elements **252** and **254** in a rotational direction relative to the upper cam member **258**. In essence, the upper cam member **258** forms an abutment to prevent rotational movement of the cutting elements **252** and **254** relative to the upper cam member **258** while allowing the cam members to move laterally. The outer sleeve **254** is retained on the outer perimeter surfaces of the upper and lower cam members **258** and **260** by the engagement of the cutting elements **252** and **254**.

[0057] As shown in FIGS. 8A and 8B, a side cutting bit adapter, generally indicated at **270**, is capable of extending and retracting laterally extendable side cutters **272** and **274** from a retracted position shown in FIG. 8A to a second extended position shown in FIG. 8B where at least a portion of each cutter **272** and **274** extend outwardly from the upper cam member **278**. This lateral movement of the side cutters **272** and **274** is actuated by rotational movement of the upper cam member **278** relative to the lower cam member **280**. The lower cam member **280** is fixedly mounted to the inner sleeve **282**, as with a setscrew **283** while the upper cam member **278** abuts against the end **284** of the sleeve **282** and can freely rotate relative to the inner sleeve **282** and the upper lower member **280**. This allows the upper cam member **278** to be rotated relative to the lower cam member **280** from a first position in which the cutting elements **272** and **274** are in a retracted state to a second position, as shown in FIG. 8B, in which the cutting elements **272** and **274** are fully extended. Reversing the direction of the drill to which the adapter **270** is attached will reverse the movement of the cutting elements **272** and **274**. As the lower cam member **280** is rotated in a clockwise direction, the base portions of the cutting elements



272 and 274 that engage corresponding grooves in the lower cam member slide along the grooves. The upper cam member 278 is provided with recesses that allow for lateral movement of the cutting elements 272 and 274 relative thereto, but that prevents any substantial movement of the cutting elements 272 and 274 in a rotational direction relative to the upper cam member 258. The cutting portions of the cutting elements 272 and 274 are housed within the upper cam member 278, which also prevents rotational movement of the cutting elements 272 and 274 relative to the upper cam member 278 while allowing the cam members to move laterally outward.

[0058] As shown in FIGS. 9A and 9B, a side cutting bit adapter, generally indicated at 285, is capable of extending and retracting laterally extendable side cutters 286 and 287 from a retracted position shown in FIG. 9A to a second extended position shown in FIG. 9B where at least a portion of each cutter 286 and 287 extend outwardly from an upper cutter guide member 288. This lateral movement of the side cutters 286 and 287 is actuated by rotational movement of the upper guide member 288 relative to a lower cutter guide member 289. The lower guide member 289 is rotatably coupled to the upper guide member 288 with outer sleeve 290. Outer sleeve 290 is fixedly coupled to the upper guide member 288, as with threaded fasteners, and rotatably coupled to the lower guide member 289 as with ring bearing 291 to which is fixedly attached. The ring bearing 291 may be of a ball bearing or surface bearing type. The ring bearing 291 abuts against the lower guide member 289 and holds it against the upper guide member 288 while allowing the lower guide member 289 to rotate relative to the upper guide member 288. The sleeve 290 includes apertures, which may be lined with bearing surfaces 296 and 297 for receiving and retaining the cutting portions 286' and 287' of the side cutters. The upper guide member 288 is provided with cutter base guiding grooves 292 and 293 that circumferentially extend from an inner radius to an outer radius of the upper guide member 288. The lower guide member 289 is provided with cutter base guide slots 294 and 295 that radially extend from an inner radius to an outer radius in the lower guide member 289. The base portions 286" and 287" of the cutters 286 and 287 are held within the guide slots 294 and 295 and will move to a full inward position when the lower guide member 289 is rotated relative to the upper guide member 288 in the direction of arrow A. Conversely, the base portions 286" and 287" of the cutters 286 and 287 will move to an outward position as shown in FIG. 9B, when the lower guide member 289 is rotated relative to the upper guide member 288 in the direction of arrow B so as to cause the cutting portion 286' and 287' to protrude from the outer sleeve 290. The upper guide member 288 is provided with an attachment portion 288' configured for attachment to a drill bit (as previously described and shown herein) and the lower guide member 289 is fixedly coupled to a drill stem coupler 297 with the drill stem coupler 297 configured for attachment to the distal end of a drill stem (as previously described and shown herein). It should be noted that while the various components are shown as being coupled together with various fastening mechanisms, such as the setscrews shown in FIGS. 9A and 9B, other means of attachment may be employed including welding and/or compression fitting. In addition, while some components are illustrated as being formed from separate components that are fixedly coupled, such components could be combined and formed from a single integral component. For example, the outer sleeve 290 and upper guide member 288, outer sleeve

290 and ring bearing 291, and/or lower guide member 289 and drill stem coupler 297 could be integrally formed. Likewise, various components that are shown to be formed from a single integral component could be formed from multiple components that are combined to form a similar structure. As such, reference herein to the term "member" or "structure" is not intended to limit such components or parts to singular integrated components or parts, but could be formed from multiple combined components or parts.

[0059] FIGS. 10A-10D illustrate a process for producing a borehole in an earthen formation having a portion therein with a wider diameter than a portion closer to the exit opening of the borehole. As shown in FIG. 10A, a drill bit assembly, generally indicated at 300, is used to drill a borehole 302 by rotating the drill bit as indicated by arrow A until a desired borehole depth is reached. In this step, the drill bit assembly operates as any other drill bit assembly known in the art for forming a borehole. Once the desired borehole depth is reached, the direction of rotation of the drill bit assembly 300 is reversed as indicated by arrow B as shown in FIG. 10B. After less than a half of a rotation of the drill bit assembly 300, the cutting elements 304 and 306 become fully laterally extended. Continued high speed counter-rotation and partial extraction of the drill bit assembly 300 causes the cutting elements 304 and 306 to engage and cut the side walls of the borehole 302 to create an enlarged diameter section 302'. After a sufficient desired length of the borehole 302 has been widened, as shown in FIG. 10C, the drill bit assembly 300 is again fully reinserted into the borehole 300 and the direction of rotation of the drill bit assembly 300 is once again reversed to be in the direction of arrow A, which causes the cutting elements 304 and 306 to retract. Once retracted, the entire drill string can be removed from the borehole 302. The resulting borehole 302 as shown in FIG. 10D is provided with an enlarged diameter section 302' (shown for illustration purposes to be relatively short in length) that could run a substantial length of the borehole 302. When the resin 310 and roof bolt 312 are inserted into the borehole 302, the resin at least partially fills the enlarged diameter section 302' and bonds to the roof bolt 312. As such, the roof bolt 312 can be tensioned by tightening the head 314 of the bolt 312 against a roof plate 316 (shown to be smaller in scale than is actually the case for illustrative purposes), even in soft or highly fragmented rock formations since the enlarged area of resin is extremely difficult to remove through the remaining smaller diameter portion 318 of the borehole 302 that is nearer the opening 320 of the borehole 302. This makes it virtually impossible for the roof bolt 312 to become dislodged from the borehole 302 resulting in a significantly more stable roof bolt installation and ultimately safer underground mine shafts.

[0060] FIGS. 11A-11D illustrate another embodiment of a drill bit assembly, generally indicated at 400 in accordance with the principles of the present invention. The drill bit assembly 400 comprises a drill stem 402, drill bit 404 and side cutting assembly 406. The side cutting assembly 406 is comprised of a first body portion 408 and a second body portion 410, with the first and second body portions 408 and 410 coupled together as by threaded mechanical attachment as illustrated or by other means known in the art, such as press fitting, pinned or set screw connection or by welded connection. The first end 412 of the first body portion 408 is configured for attachment to the distal end of the drill string 402 and the second distal end 414 of the second body portion 410 is configured for attachment to the drill bit 404. The first and

second body portions **408** and **410** are fixedly coupled to each other such that rotation of the first body portion **408** by the drill string **402** causes rotation of the second body portion **410** and the drill bit **404**. The first body portion **408** defines a cylindrical recessed portion **414** that has a diameter that is less than the diameter of the proximal end **412** of the first body portion. The recessed portion **414** is nonconcentrically oriented relative to a longitudinal axis of the drill bit assembly **400**. In other words, the center of the recessed portion **414** is offset relative to the longitudinal axis of the drill bit assembly **400**. A cutting sleeve **416** is disposed around the recessed portion **416** and is partially freely rotatable relative thereto between a first position as shown in FIG. 11B and a second position as shown in FIG. 11A. A cutting element **418** is disposed on an outer surface of the sleeve **416**. In the first position, the cutting element **418** is in a retracted position and positioned within a recess **420** formed by the recessed portion **416** on one side of the first body **408**. When the sleeve is rotated approximately 180 degrees to the second position, the cutting element **418** is rotated to an extended position in which the cutting element **418** extends beyond the outermost surfaces of the first and second bodies **408** and **410** so as to engage a sidewall of a borehole and cut the sidewall upon rotation of the drill bit assembly **404**.

[0061] Movement of the sleeve **416** from the first position to the second position and back is actuated by the direction of rotation of the drill bit assembly **400**. As shown in FIGS. 11C and 11D, the cutting element **418** is provided with a leading edge that provides essentially a cutting tooth that will engage the surface of the sidewall of a borehole when the direction of rotation of the drill bit is reversed. As shown, the cutting element may have a concave leading edge for engaging and cutting a sidewall of a borehole. In a forward direction of rotation for initially drilling the borehole, which may be in a clockwise direction when viewed from the viewpoint of the driller, the tapered top surface **422** of the cutting element **418** will cause a slight impingement of debris in the borehole between the cutting element **418** and the sidewall of the borehole. This will force the sleeve **416** to rotate to the extent possible in a counter-clockwise direction relative to a clockwise direction of rotation of the drill bit **404**. This will cause the cutting element **418** to be positioned as shown in FIGS. 11B and 11D.

[0062] When the direction of rotation of the drill bit is reversed, the leading edge **424** of the cutting element **418** will engage and grab the sidewall of the borehole causing the sleeve to rotate from the first position shown in FIGS. 11B and 11D to a second position shown in FIGS. 11A and 11C. The rotation of sleeve **416** is limited to approximately 180 degrees relative to the first body **408** by the engagement of a spherical bearing **426** that is interposed between the first body portion **408** and the sleeve **416**. A stepped radial surface **428** is circumferentially provided on the first body portion proximate the second body portion **410**. A semicircular groove is disposed in the surface **428** and extends slightly more than 180 degrees around the first body **408** within the recessed portion **414**. The sleeve **416** is provided with an inwardly extending shelf **430** at one end thereof that is positioned over the surface **428**. The shelf **430** has an inner surface that defines a second semicircular groove for receiving a portion of the bearing **426**. Again the second groove extends circumferentially along the shelf **430** approximately slightly more than 180 degrees. The shelf portion **430** of the sleeve **416** has a longitudinal thickness that extends between the surface **426** and the

proximal end **432** of the second body portion **410** so as to abut against the second body portion and to be held between, but freely rotatable to a certain extent, between the first and second body portions **408** and **412**. Engagement of the bearing **426** with the ends **434** and **436** of the groove **438** in the first body portion **408** and the ends of the groove **442** in the sleeve **416** will allow limited free rotation of the sleeve **416** relative to the first and second bodies **408** and **412** between the first and second positions as illustrated.

[0063] FIGS. 12A-12D illustrate another embodiment of a drill bit assembly, generally indicated at **500** in accordance with the principles of the present invention that has a configuration similar to the drill bit assembly **400** illustrated in FIGS. 11A-11D. In this illustrated embodiment, rotation of the sleeve **516** relative to the first body portion **508** is limited by direct engagement between the sleeve **516** and the first body portion **508**. The distal end **509** of the first body portion **508** is provided with a stepped surface **528** in which the height of the surface **528** varies around the circumference of the first body **508** at the distal end **509** at the recessed portion **520**. The sleeve **516** includes an inwardly depending shelf or wall **530** that has a portion **531** that is thicker. This thicker portion resides within the lower portion **529** of the stepped surface **528** and can slide relative thereto between the ends **533** and **535** of the lower portion **529**. Movement between these two positions of the sleeve **516** causes approximately 180 degrees of rotation of the cutting element **518** relative to the body **508** to move the cutting element **518** from a cutting position shown in FIGS. 12A and 12C to a non-cutting or retracted position shown in FIGS. 12B and 12D.

[0064] FIGS. 13A-13D illustrate yet another embodiment of a drill bit assembly, generally indicated at **600** in accordance with the principles of the present invention. The drill bit assembly **600** includes a bit **602** and stem **604** and side cutting assembly **606**. The side cutting assembly **606** has a first portion **608** configured for attachment to the bit **602** and a second portion **610** configured for attachment to the stem **604**. The first portion **608** and second portion **610** are coupled together, as by a threaded connection **612** or other means of mechanical fastening known in the art. The side cutting assembly **606** includes a central, longitudinally extending aperture or bore **614** that is in fluid communication with the ends **616** and **618** of the side cutting assembly **606**. A pair of side cutting elements **620** and **622** is pivotally coupled to the body of the side cutting assembly **606**. More specifically, recesses **624** and **626** are formed in the outer surface **628** of the second portion **610** for housing the side cutting elements **620** and **622**. Retaining pins **630** and **632** are positioned within longitudinally extending boreholes that are in communication with the recesses **624** and **626**, respectively, to pivotally retain one end of a respective cutting element **620** and **622**. As such, while one end of each cutting element **620** and **622** is pivotally held within a respective recess **624** and **626**, the cutting end of each cutting element **620** and **622** can radially and outwardly extend from the second portion **610**. The retaining pins **630** and **632** are held within their respective bore holes **631** and **633** by engagement of the first portion **608** with the second portion **610** such that the proximal end **634** of the first portion **608** abuts against the distal end **636** of the second portion **610** and the distal ends of the retaining pins **630** and **632**.

[0065] Referring specifically to FIGS. 13B and 13C, each cutting element **620** and **622** can pivot from a first recessed position as shown in FIG. 13B to a second radially extended position as shown in FIG. 13C. The cutting elements **620** and

622 have a generally crescent shape that substantially matches the crescent shape of the respective recess 624 and 626 so that when the cutting elements 620 and 622 are fully recessed as shown in FIG. 13B, the outer surfaces 621 and 623 substantially match the radius of the outer surface 625 of the second portion 610. The pivoting end of each cutting element 620 and 622 has a radius that substantially matches the radius of the respective recess 624 and 626 at the pivoting end.

[0066] The opposite or cutting end 640 and 641 of each cutting element 620 and 622, respectively, defines an effective radius that is substantially the same as the radius of a circle with its center at the center of the respective retaining pin 630 and 632. The adjacent surface of each recess 624 and 626 has a similar curvature. This allows the cutting end of each cutting element 620 and 622 to pivot out of each recess 624 and 626 while maintaining close proximity to the adjacent surface of the respective recess 624 and 626 to prevent debris generated while cutting from impeding the movement of the cutting elements from the retracted position to the radially extended position and back to the retracted position during each side cutting operation as herein previously described with reference to other embodiments of the invention. In addition, each cutting element 620 and 622 is provided with a concave cutting surface 620' and 622' on the cutting end 640 and 641 that forms a cutting edge for cutting rock from a borehole when the cutting elements are extended as shown in FIG. 13C.

[0067] Each cutting element 620 and 622 pivots about its respective retaining pin 630 and 632 and is outwardly biased by respective spring members 642 and 643, such as a coil spring or other biasing devices known in the art. When the side cutting assembly 606 is rotated in a first direction, in this example counter-clockwise when being viewed from the down hole position as illustrated in FIG. 13B, the side cutting elements 621 and 622 are forced into their recessed position by the engagement of the side wall of the borehole being drilled with the outer surfaces 621 and 622 of each cutting element 620 and 622.

[0068] As specifically illustrated in FIG. 13C, when the rotation of the side cutting assembly 606 is reversed, the force of the springs 642 and 643 cause the cutting elements 620 and 622 to pivot outwardly until the point P at which the radius of the retained end of the cutting element 620 and 622 changes abuts against the respective adjacent surface 644 and 645 of the second portion 610 to prevent further rotation of the cutting elements 620 and 622. In this position, the concave cutting surfaces 620' and 622' are substantially fully exposed so that side wall cutting will be generated to increase the down hole bore diameter of the borehole being cut. Essentially, the exposed cutting surfaces 620' and 622' form teeth that engage the side wall of the borehole so that, when combined with the spring force being applied to each cutting element 620 and 622, they cause the cutting elements 620 and 622 to stay in the radially extended position so long as the side cutting assembly is being rotated in a clockwise direction when viewed from the down hole position as shown in FIG. 13C. Reversal of the rotation of the side cutting assembly in a down hole location will cause the side cutting elements 620 and 622 to retract so that the tool can be retracted from the borehole after a desired length of an enlarged down hole bore size has been cut.

[0069] FIGS. 14A-14E illustrate yet another embodiment of a drill bit assembly, generally indicated at 700 in accordance with the principles of the present invention. The

drill bit assembly 700 includes a bit 702 and stem 704 and side cutting assembly 706. The side cutting assembly 706 has a first portion 708 configured for attachment to the bit 702 and a second portion 710 configured for attachment to the stem 704. The first portion 708 and second portion 710 are coupled together with a longitudinally extending sleeve 712 that is fixedly coupled to the first portion 708 and rotatably coupled to the second portion 710. The sleeve 712 is held relative to the first portion with a setscrew 714. The proximal end 716 of the sleeve 712 includes a circumferential flange 718 that abuts against an inside toroidal recess 720. The sleeve 712, and more particularly the flange 718 interconnects the first portion 708 to the second portion 710 in a manner in which the second portion 710 can rotate relative to the first portion 708.

[0070] The first and second portions 708 and 710 also include internal abutment surfaces 722 that are positioned with a circumferential groove 724 that partially extends around the sleeve 712 to limit the amount of rotation between the first and second portions 708 and 710. As such, the forces encountered during drilling and retraction by the side cutting assembly 706 are transferred between the first and second portions 708 and 710 by the abutment surfaces 722 and not necessarily by the cutting elements or cutting element actuation members as hereinafter described.

[0071] The side cutting assembly 706 includes two side-cutting elements 730 and 732. The side cutting elements 730 and 732 reside within recesses 731 and 733, respectively, formed in the outer sidewall of the second portion 710. The recesses 731 and 733 have a shape and size that substantially matches a shape and size of the cutting elements 730 and 732 so that debris generated from the cutting process is less likely to impinge movement of the cutting elements 730 and 732 from a first retracted position as shown in FIG. 14C to a second extended position as shown in FIG. 14D. The cutting elements 730 and 732 and associated recesses 731 and 733 are configured similarly to the cutting elements and recesses illustrated in FIGS. 13A-13C. Rather than being outwardly biased with a spring or other biasing element, however, the cutting elements 730 and 732 are actuated between the first and second positions as a result of relative rotational movement of the first portion 708 and the second portion 710.

[0072] Actuation members 734 and 736 (see also FIG. 14B) are fixedly coupled to the first portion 708 and longitudinally extend through respective crescent shaped slots 738 and 740 formed in the second portion 710 at the interface between the first and second portions 708 and 710 as shown in FIG. 14C. The actuation members 734 and 736 engage with corresponding curved slots 742 and 744 formed in the cutting elements 730 and 732, respectively. The curved slots are oriented so that the end of the slot closest to the retaining pins 746 and 748 about which the respective cutting elements 730 and 732 pivot is at a greater radial distance than the opposite end of the curved slot. As the first and second portions 708 and 710 rotate relative to one another, the actuating members 734 and 736 move along the curved slots 742 and 744, respectively, to extend or retract the cutting elements 730 and 732 depending on the direction of relative rotation. As such, during a drilling operation, when the drill bit 702 is driven into a formation, the first and second portions 708 and 710 are rotated and/or held in a position in which the cutting elements 730 and 732 are retracted as shown in FIG. 14C. When the rotation of the drill stem 704 is reversed and the drill bit 702 is held against the bottom of a borehole that has been formed, the second portion 710 will rotate relative to the first portion 708 about the sleeve

712 until the cutting elements 730 and 732 are fully extended as shown in FIG. 14D to allow the cutting elements 730 and 734 to widen the diameter of the borehole that has been cut. As the drill bit assembly 700 is retracted while being rotated in the opposite direction, the cutting elements 730 and 732 will form a down hole borehole that is wider than the remainder of the borehole that is closer to the exit of the borehole. Reversing the rotation of the drill bit assembly 700 back to the original direction of rotation used for the initial borehole formation will cause the second portion 710 to rotate relative to the first portion 708 causing the cutting elements 730 and 734 to retract back into the second portion 710 so that the drill bit assembly 700 can be fully retracted from the borehole.

[0073] As shown in FIG. 15, a side cutting adapter 800 in accordance with the principles of the present invention includes a first body portion 802 having a first end 804 configured for mating with a distal end of a drill string or stem (not shown). The first body portion 802 is mated to a second body portion 806 having a second end 808 configured for mating with a conventional drill bit (not shown). Disposed between the first and second body portions 802 and 806 is a cutting ring 810. The cutting ring 810 is provided with a cutter 812 that outwardly extends from an exterior surface 814 of the cutting ring 810. The cutting ring 810 is disposed within a channel 816 formed by and between proximal ends of the first and second body portions 802 and 806. The cutting ring 810 can freely rotate within the channel 816 between a first position in which the cutter 812 is substantially disposed within the channel 816 to a second position in which the cutter 812 is exposed as illustrated such that the cutting edge 818 outwardly extends from the outer surfaces 820 and 822 of the first and second body portions, respectively. In the second position, the cutting edge 818 defines a radius from the longitudinal axis of the first and second body portions 802 and 806 that is greater than a cutting radius of the drill bit to which the adapter 800 is attached. In the first position, the cutting edge 818 defines a radius from the longitudinal axis of the first and second body portions 802 and 806 that is less than a cutting radius of the drill bit to which the adapter 800 is attached. The cutter may be angled relative to the longitudinal axis of the cutter 812 to direct cuttings away from the cutter 812.

[0074] As shown in FIGS. 16A, 16B and 16C, the cutting ring 810 is comprised of a hollow cylindrical body 830. The cutter 812 extends radially from the outer surface 814 of the body 830. The cutter 812 may be formed from a separate material, such as tungsten carbide that is welded, sintered or otherwise attached to the body 830. In addition the cutter 812 may have a portion that is embedded in the body 830 to form a mechanical attachment between the cutter 812 and the body 830. An abutment 832 depends from an end surface 834 of the body 830. The abutment surface 832 limits the rotational movement of the cutting ring 810 by abutting against abutment surfaces in the second body. That is, as the cutting ring 810 is rotated between a first position and a second position, the abutment engages with the first body to limit rotation of the cutting ring to 810 about 180 degrees.

[0075] As shown in FIGS. 17A, 17B and 17C, the first body portion 802 is generally cylindrical in shape with a first end 804 defining a hexagonally shaped recess for mating with a corresponding hexagonally shaped distal end of a drill stem. The opposite end 840 of the body 802 has a smaller cylindrical portion 842 for mating with the second body portion 806 (see FIG. 15). The body 802 also defines a nonconcentric cylindrical portion 844 configured for receiving the cutting

ring 810. Thus an outer diameter of the nonconcentric cylindrical portion 844 is slightly less than an inner diameter of the cutting ring 810 so that the cutting ring 810 can freely rotate on the nonconcentric cylindrical portion 844.

[0076] As shown in FIGS. 18A, 18B and 18C, the second body portion 806 has a first end 850 having a cylindrical opening configured for mating with the end 840 of the first body portion 802 and a second end 808 having a hexagonal cross-section configured for mating with a drill bit. The first end 850 of the second body portion 806 has a stepped configuration so as to form a channel between the second body portion 806 and the cutting ring 810 for receiving the abutment 832 of the cutting ring. The abutment surfaces 852 and 854 limit the movement of the cutting ring 810 as the ring 810 rotates between a first position when the abutment 832 contacts the surface 852 and a second position when the abutment 832 contacts the surface 854. The abutment surfaces 852 and 854 are radially spaced greater than 180 degrees apart to allow sufficient rotation of the cutting ring 810 to move the cutter 812 from a retracted position to a cutting position.

[0077] FIGS. 19A-19F illustrate various steps in a method of cutting in accordance with the principles of the present invention. As shown in FIG. 19A, a drill string 900 is configured to drill a borehole 910 into an earthen formation 912. The drill string 900 is rotated in a first direction to allow the drill bit to cut into the formation. Once a desired depth of the borehole 910 is reached, as shown in FIG. 19B, the drill string 900 is retracted a distance within the borehole 910 from a first position to a second position. Once the drill string is moved to the second position, as shown in FIG. 19C, the rotation of the drill string 900 is reversed. The reversal of the drill string 900 causes the cutter 812 of the cutting ring 810 to engage the side wall 914 of the borehole 910, once the cutter 812 engages the side wall 914, continued rotation of the drill string 900 causes the cutting ring 810 to rotate relative to the first and second body portions 802 and 806 until the abutment prevents further rotation of the cutting ring 810. In this position, the cutter is fully extended relative to the first and second body portions 802 and 806. As further shown in FIG. 19C, with the cutter 812 extended, the drill string is driven back into the borehole 910 toward the first position. As shown in FIG. 19D it is desirable to drive the drill string 900 back into the borehole 910 at a rate that allows the cutter 812 to fully remove the full diameter of the sidewall of the borehole 910 as the drill string advances back into the borehole 910. The desired rate of advancement may be equal to or less than the width of the cutter 812 for each rotation of the drill string to ensure that the cutter 812 removes the entire sidewall between the second position and another down hole position where the diameter enlargement is ceased. As such, as the drill string 900 is advanced, as shown in FIG. 19D, the cutter 812 enlarges the diameter of the borehole until the drill string reaches a desired position that may be at the first position or may be at a position that is less than the first position. As shown in FIG. 19E, once the desired depth of enlargement is reached, the direction of rotation of the drill string 900 is again reversed. This causes the cutting ring to rotate back to a first retracted position so that the drill string 900 can be removed from the borehole 910 as shown in FIG. 19F. Once the drill string 900 is removed from the borehole, various earth anchoring systems, such as a mine roof bolt and associated epoxy resin can be inserted into the enlarged borehole 910. The resulting enlarged portion 910' of the borehole 910 provides additional anchoring support for such systems by allowing the hardened epoxy resin to

form within this enlarged portion **910'** that provides additional resistance to movement of the anchoring system relative to the formation **912**, as compared to the same anchoring system attached to a consistent diameter borehole.

**[0078]** While not specifically illustrated herein, the present invention will have other applications where it is desirable to secure an anchoring system of some design into an earthen borehole. Thus, while the present invention has been described with reference to certain illustrative embodiments to illustrate what is believed to be the best mode of the invention, it is contemplated that upon review of the present invention, those of skill in the art will appreciate that various modifications, combinations and other adaptations may be made to the present embodiments without departing from the spirit and scope of the invention as recited in the claims. It should be noted that reference to the terms "ground anchor" or "anchoring system" in the specification and claims is intended to cover all types of devices used attach to or to secure or retain earthen formations, without limitation. Indeed, as discussed the drilling apparatus of the present invention may have particular utility in many different applications where it is desirable to secure an object into a hole drilled into a rock, cement or other hard formation. The claims provided herein are intended to cover such modifications, adaptations and combinations and all equivalents thereof. Reference herein to specific details of the illustrated embodiments is by way of example and not by way of limitation.

What is claimed is:

**1.** A method for forming a borehole in an earthen formation comprising;

rotating a drill bit coupled to a drill stem in a first direction into an earthen formation to form a borehole having a first diameter between an opening of the borehole and a first down hole position;

retracting the drill bit to a second down hole position from the first down hole position while retaining the drill bit within the borehole;

rotating the drill bit in a second direction causing a side cutting element coupled to the drill bit to engage a side wall at a first location of the borehole and to extend a radial distance from a longitudinal axis of the drill bit that is greater than an outer radius of the drill bit,

driving the drill bit back into the borehole while continuing to rotate the drill bit in the second direction to allow the side cutting element to enlarge a portion of the borehole between the first location and a second location that is closer to the first down hole position;

reversing the rotation of the drill bit from the second direction to the first direction causing the side cutting element coupled to the drill bit to disengage the side wall and to retract a radial distance from the longitudinal axis of the drill bit that is equal to or less than the outer radius of the drill bit; and

removing the drill bit and drill stem from the borehole.

**2.** The method of claim **1**, further comprising coupling a side cutting apparatus between the drill bit and the drill string.

**3.** The method of claim **2**, further comprising providing the side cutting apparatus with a rotatable cutting ring whereby rotation of the drill bit in the first direction within the borehole

causes the cutting element of the cutting ring to retract and rotation of the drill bit in the second direction within the borehole causes the cutting element to engage a side wall of the borehole and rotate the cutting ring thereby extending the cutting element into the sidewall of the borehole.

**4.** The method of claim **1**, further comprising providing the side cutting apparatus with a first end configured for coupling to the drill bit and a second end configured for coupling to a drill stem.

**5.** The method of claim **4**, further comprising providing the side cutting apparatus with:

a first body portion having a first end configured for coupling to a drill bit and a central vacuum bore,

a second body portion coupled to the first body portion having a second end configured for coupling to a drill stem, one of the first body portion and second body portion having a nonconcentric cylindrical portion with a diameter that is less than a diameter of the first body portion proximate the first end,

a ring disposed on the nonconcentric cylindrical portion and being partially rotatable relative thereto between a first position and a second position;

at least one cutting element disposed on the ring so that when the ring is in the first position, the at least one cutting element is in a retracted position and when the ring is in the second position the at least one cutting element is in an extended position for cutting a sidewall of a borehole to enlarge a diameter of the borehole while the at least one cutting element is in the extended position, the at least one cutting element having a leading edge that is spaced radially farther from the longitudinal axis of the first body when the at least one cutting element is in the extended position and wherein the at least one cutting element engages a sidewall of a borehole when rotation of the drill bit is reversed.

**6.** The method of claim **5**, further comprising causing the ring to rotate and the at least one cutting element to engage the sidewall of the borehole when the drill bit is reversed and to force the at least one cutting element into further engagement with the sidewall of the borehole.

**7.** The method of claim **5**, further comprising coupling the ring to the nonconcentric cylindrical portion so that the ring is freely rotatable approximately one hundred eighty degrees between the first position and the second position.

**8.** The method of claim **5**, further comprising providing a channel between the second body portion and the ring an abutment on the ring extending from the ring into the channel to limit rotation of the ring relative to the second body by engagement of the abutment with ends of the channel.

**9.** The method of claim **1**, further comprising driving the cutting element into the borehole at a rate that removes substantially all of the sidewall of the borehole between the first location and the second location.

**10.** The method of claim **1**, further comprising inserting an anchoring system into the borehole after removal of the drill bit and drill stem from the borehole.

\* \* \* \* \*