



US 20200135164A1

(19) **United States**

(12) **Patent Application Publication**  
**Thomsen et al.**

(10) **Pub. No.: US 2020/0135164 A1**

(43) **Pub. Date: Apr. 30, 2020**

(54) **DIGITAL MICROPHONE NOISE  
ATTENUATION**

*H04R 3/00* (2006.01)

*H04R 17/02* (2006.01)

*H03M 7/32* (2006.01)

*H04R 19/04* (2006.01)

*H04R 19/00* (2006.01)

(71) Applicant: **Knowles Electronics, LLC**, Itasca, IL (US)

(72) Inventors: **Henrik Thomsen**, Holte (DK); **Yu Du**, Itasca, IL (US)

(52) **U.S. Cl.**

CPC ..... *G10K 11/17853* (2018.01); *B81B 3/0021*

(2013.01); *H04R 3/005* (2013.01); *H04R*

*17/02* (2013.01); *G10K 2210/3028* (2013.01);

*H04R 19/04* (2013.01); *H04R 19/005*

(2013.01); *B81B 2201/0257* (2013.01); *H03M*

*7/3004* (2013.01)

(73) Assignee: **Knowles Electronics, LLC**, Itasca, IL (US)

(21) Appl. No.: **16/731,905**

(22) Filed: **Dec. 31, 2019**

**Related U.S. Application Data**

(63) Continuation of application No. 16/124,794, filed on Sep. 7, 2018, now Pat. No. 10,559,293.

(60) Provisional application No. 62/556,181, filed on Sep. 8, 2017.

(57)

**ABSTRACT**

A digital microphone device includes circuitry that can reduce the risk of noise caused due to an idle tone frequency component in a digital signal output by the digital microphone device. In stereo mode and other applications where interference occurs between two or more such microphones, each microphone device includes a digital output having a corresponding idle tone frequency, one of which is offset to shift noise components outside of a desired frequency range.

**Publication Classification**

(51) **Int. Cl.**

*G10K 11/178* (2006.01)

*B81B 3/00* (2006.01)

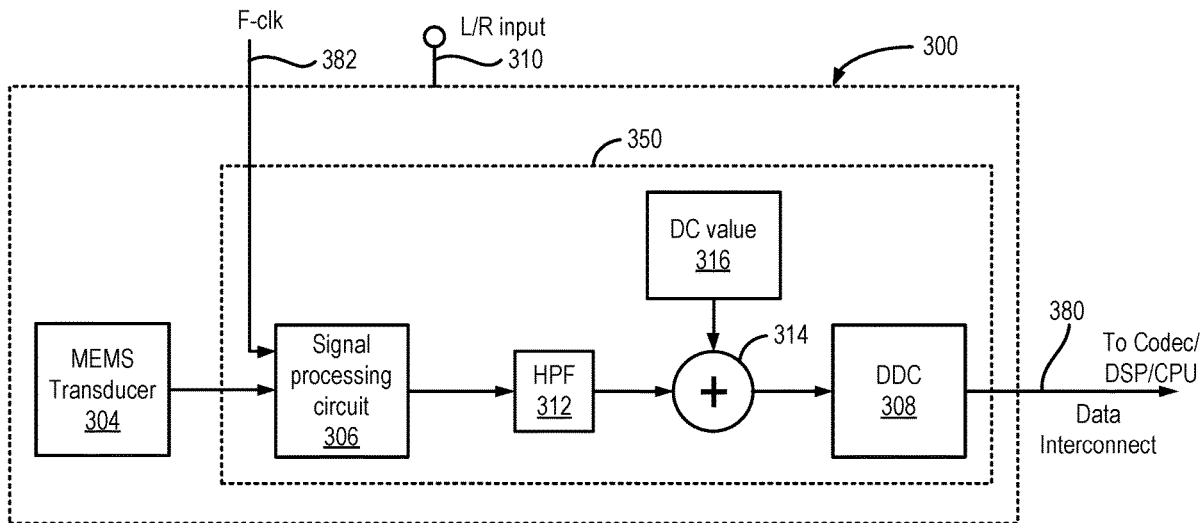

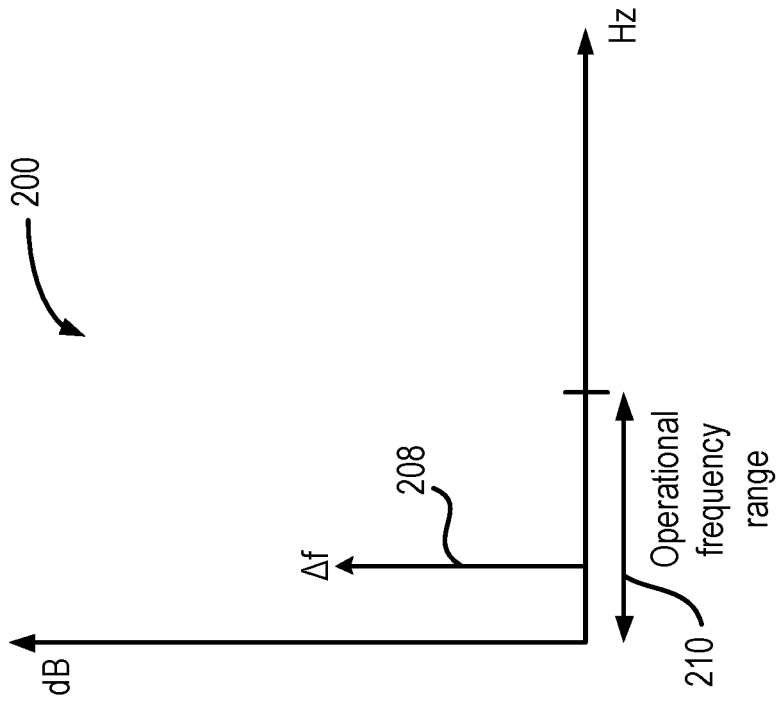

Figure 2

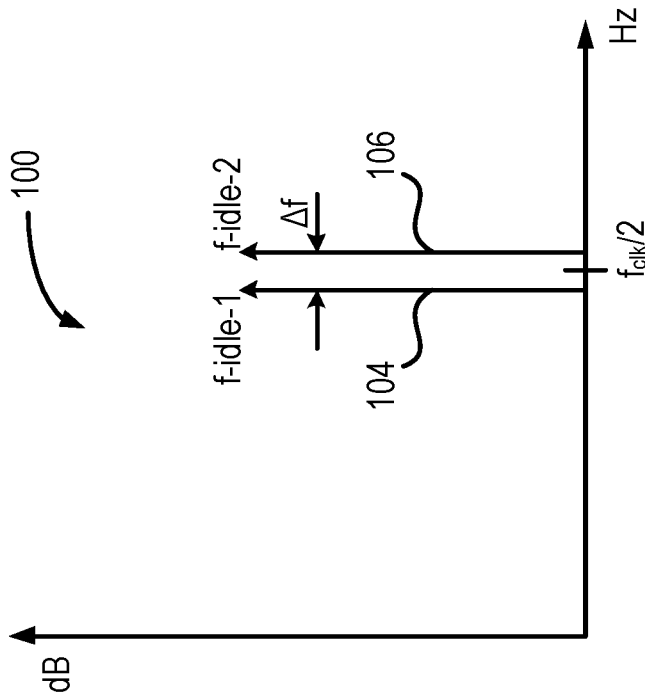

Figure 1

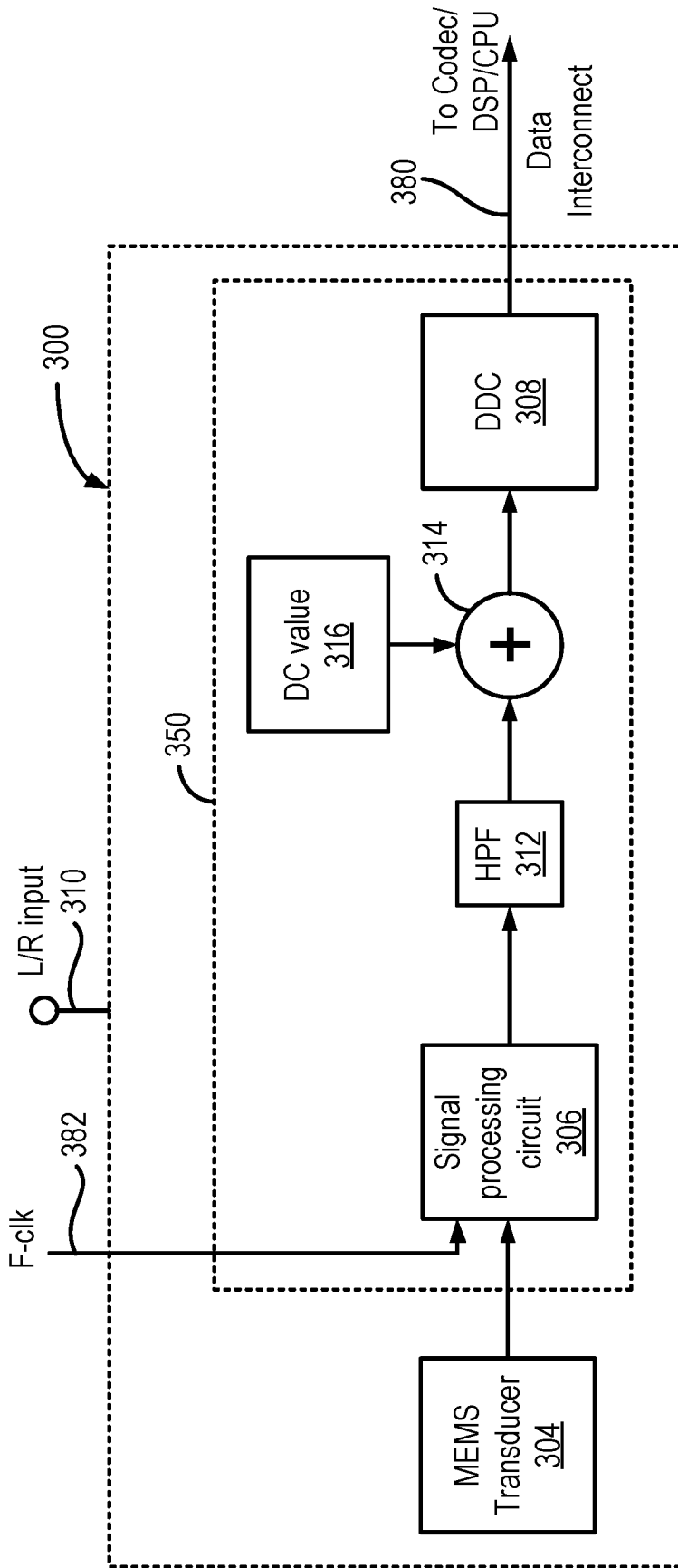

Figure 3

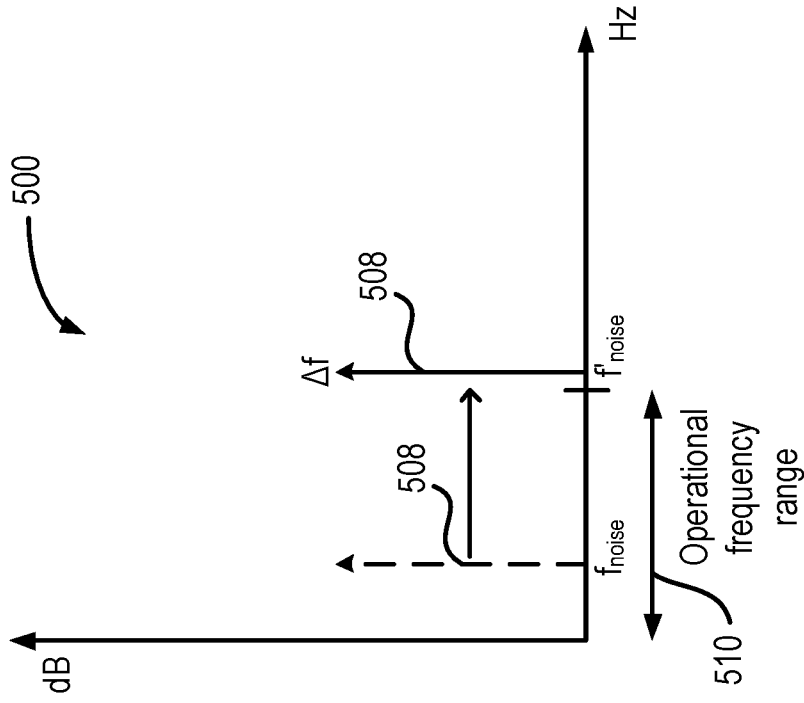

Figure 5

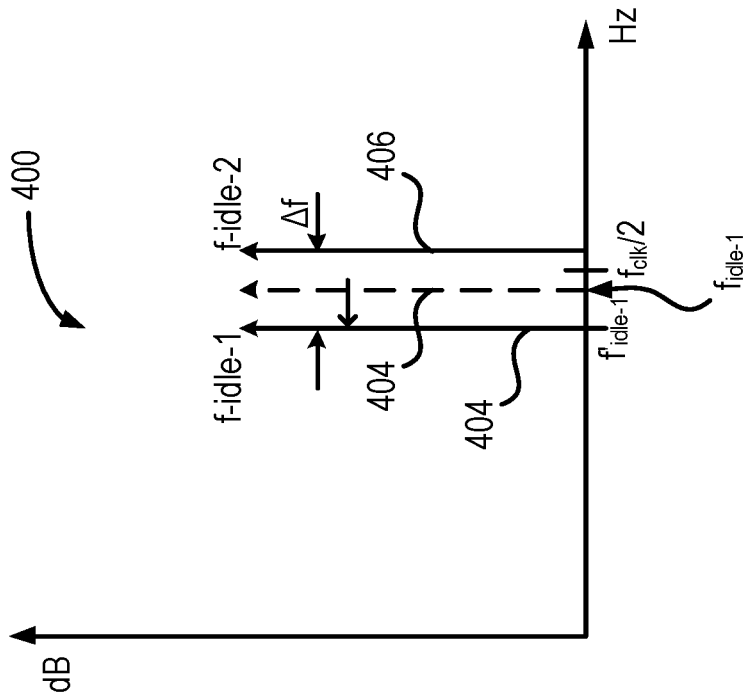

Figure 4

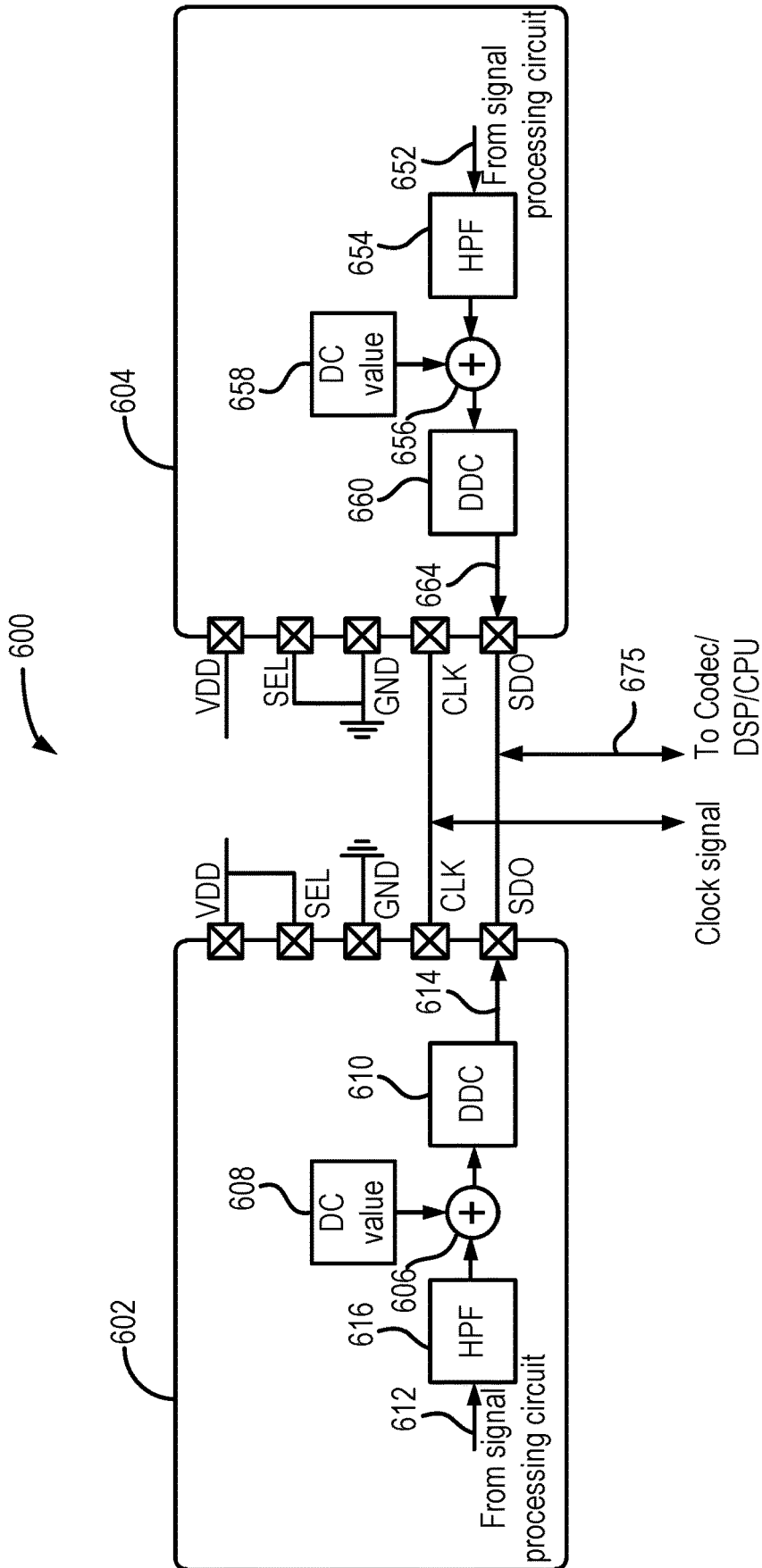

Figure 6

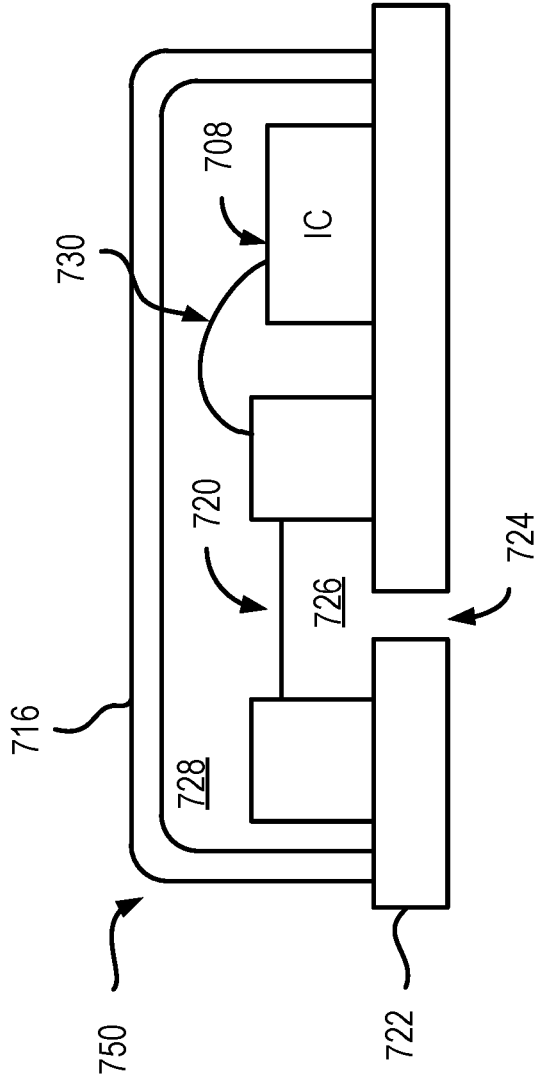

Figure 7

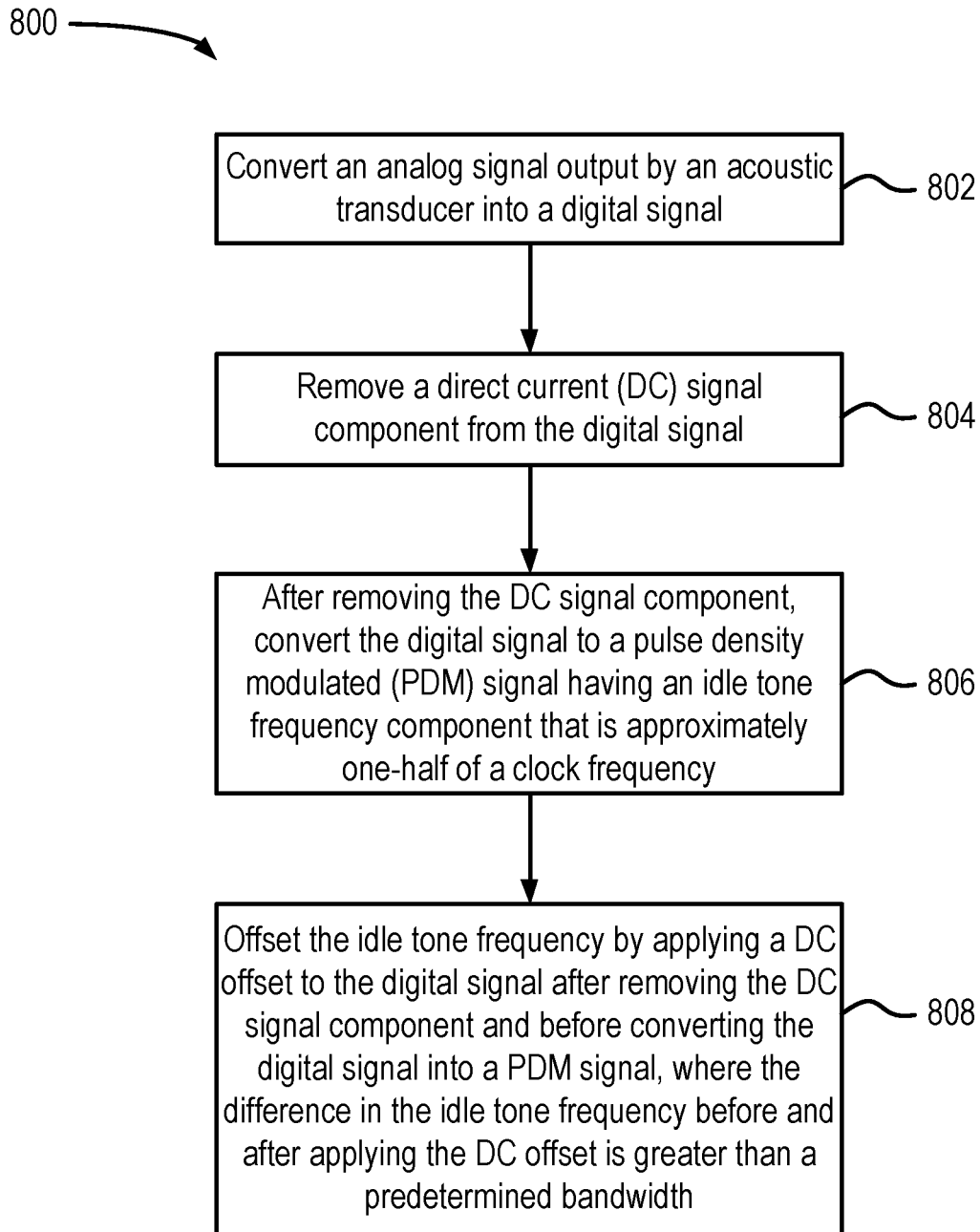

Figure 8

900

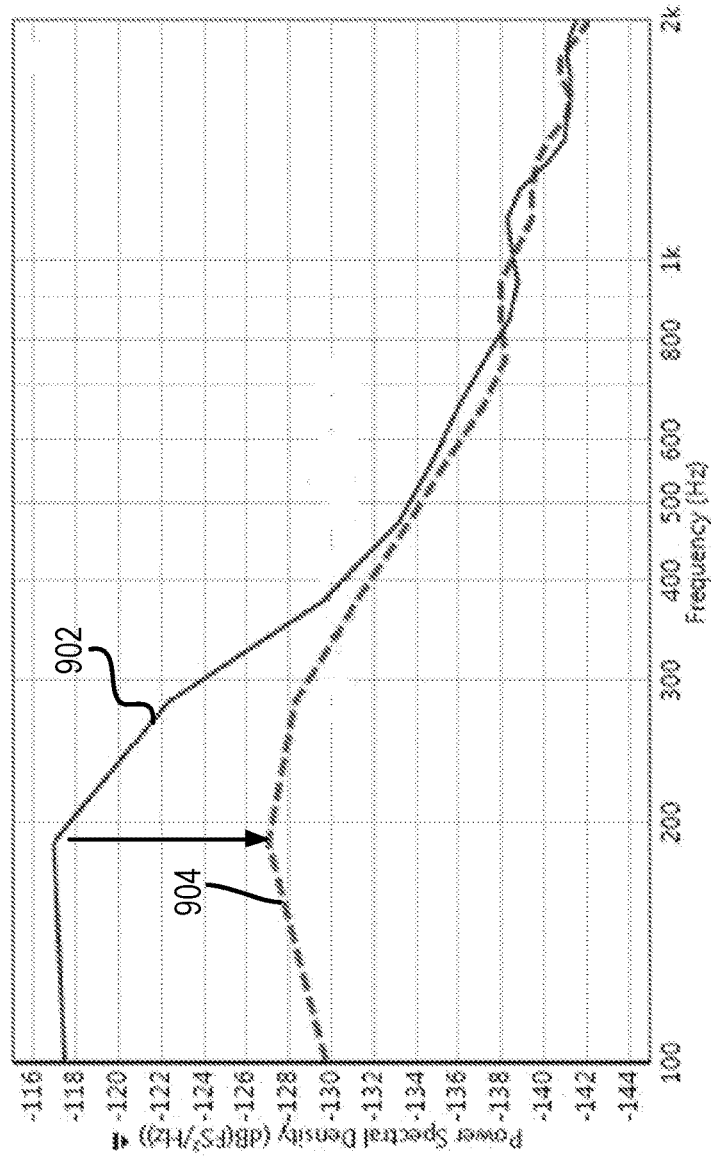

Figure 9



## DIGITAL MICROPHONE NOISE ATTENUATION

### CROSS-REFERENCE TO RELATED APPLICATIONS

[0001] This application is a continuation of U.S. patent application Ser. No. 16/124,794 filed Sep. 7, 2018, which claims the benefit of and priority to U.S. Provisional Patent Application No. 62/556,181, filed Sep. 8, 2017, the entire contents each of which are incorporated herein by reference.

### FIELD OF THE DISCLOSURE

[0002] The present disclosure relates generally to microphones and more particularly to reduction of noise or interference in digital microphones, for example in digital microelectromechanical systems (MEMS) microphone devices, and methods therefor.

[0003] The present disclosure relates generally to microphones and more particularly to reduction of noise or interference in digital microphones, for example in digital microelectromechanical systems (MEMS) microphone devices, and methods therefor.

### BACKGROUND

[0004] Microelectromechanical system (MEMS) microphones are deployed in various devices including consumer electronics and vehicles among other applications and host devices. Such microphones include an assembly of one or more transducers and one or more integrated circuits typically disposed in a housing formed by a lid or cover fastened to a substrate having an external device interface. The transducer is embodied as a MEMS die that detects pressure changes within the housing via an acoustic port through the lid or substrate and the interface is typically configured for surface mounting on a printed circuit board using reflow soldering or other technology.

[0005] Some MEMS microphones output a digital signal having an idle tone frequency based on a frequency of the digital circuit clock. For example, PDM microphones output a 1-bit PDM signal including an idle tone frequency that is one-half of the clock frequency. In stereo and other applications where two or more microphones are employed, mixing of the idle tone frequencies or other effects may cause unwanted noise at the output of one or both microphones. The idle tone frequencies may be slightly different due to manufacturing variations or other causes.

[0006] FIG. 1 depicts a first plot 100 showing different idle tone frequencies generated by left and right microphones in a stereo system in the frequency spectrum. In particular, the first plot 100 depicts a first idle tone frequency 104 (labeled “f-idle-1”) and a second idle tone frequency 106 (labeled “f-idle-2”) generated by left and right microphone signals, respectively, in a stereo system. FIG. 2 depicts a second plot 200 illustrating an intermodulation (IM) component 208 (labeled “Δf”) resulting from mixing the different idle tone frequencies f-idle-1 104 and f-idle-2 106 in FIG. 1, wherein the IM component 208 lies in the operational frequency range 210 where it may cause noise or interference.

### BRIEF DESCRIPTION OF THE DRAWINGS

[0007] The foregoing and other features of the present disclosure will become more fully apparent from the following description and appended claims, taken in conjunc-

tion with the accompanying drawings. Understanding that these drawings depict only several embodiments in accordance with the disclosure and are, therefore, not to be considered limiting of its scope, the disclosure will be described with additional specificity and detail through use of the accompanying drawings.

[0008] FIG. 1 depicts a first plot showing different idle tone frequencies generated by left and right microphones in a stereo system.

[0009] FIG. 2 depicts a second plot illustrating an intermodulation component resulting from mixing of the different idle tone frequencies depicted in FIG. 1.

[0010] FIG. 3 depicts a digital microphone device for processing acoustic signals.

[0011] FIG. 4 depicts a third plot of idle tones produced by two different microphone devices of the type shown in FIG. 3.

[0012] FIG. 5 depicts a fourth plot of an intermodulation frequency component resulting from mixing the idle tones shown in FIG. 4.

[0013] FIG. 6 illustrates a system including a left digital microphone device and a right digital microphone device connected in stereo mode.

[0014] FIG. 7 illustrates a cross-sectional view of an example bottom-port digital microphone assembly.

[0015] FIG. 8 shows a flow diagram of an example process 800 used for reducing idle tone frequency noise.

[0016] FIG. 9 depicts example test data showing an attenuation of a noise component in a digital microphone system.

[0017] In the following detailed description, reference is made to the accompanying drawings, which form a part hereof. In the drawings, similar symbols typically identify similar components, unless context dictates otherwise. The illustrative embodiments described in the detailed description, drawings, and claims are not meant to be limiting. Other embodiments may be utilized, and other changes may be made, without departing from the spirit or scope of the subject matter presented here. It will be readily understood that the aspects of the present disclosure, as generally described herein, and illustrated in the figures, can be arranged, substituted, combined, and designed in a wide variety of different configurations, all of which are explicitly contemplated and make part of this disclosure.

### DETAILED DESCRIPTION

[0018] The present disclosure describes devices and methods therein for reducing noise in digital microphone devices, such as those incorporating microelectromechanical (MEMS) transducers. In some embodiments, the devices and techniques described reduce noise caused by the mixing of idle tone frequencies or other effects in applications where multiple microphones are employed, for example where multiple microphones share a common bus or where multiple microphones are otherwise subject to interfering signals from one another. In one embodiment, the idle tone frequency of one of two digital microphone devices may be offset relative to the idle tone frequency of the other microphone device to shift the intermodulation (IM) or mixing components outside of the frequency range of interest according to the following expression:

$$|f_{idle1} - f_{idle2}| > \text{bandwidth of interest}$$

**[0019]** For audio applications, the bandwidth of interest is somewhere between about 20 Hz and about 20 kHz. The perceptible audio frequency range varies from person to person and depends generally on genetic variation and age among other factors. In other applications however the bandwidth of interest may lie partially or wholly outside the audio band. More generally, where more than two microphones are subject to interference from one another, the idle tone frequencies of all the microphone outputs may be separated to avoid noise in the frequency band of interest. In one embodiment, each microphone is hardwired to provide an output at one idle mode frequency or another. For stereo mode applications, two microphones hardwired for different idle tone frequencies could be used to avoid interference or noise. In an alternative embodiment, one of the two microphones is configured to selectively offset its idle mode frequency relative to the other microphone under certain conditions, for example when used in a stereo mode. In applications requiring more than two microphones, noise may be eliminated or reduced by using microphones having different idle tone frequencies. Here too, different hardwired microphones may be used, or alternatively the microphones may be selectively configured for different idle tone frequencies when necessary to shift the IM components beyond the frequency band of interest.

**[0020]** In an embodiment, a digital microphone assembly converts an analog signal output by an acoustic transducer to a digital signal. In one implementation, the transducer is a microelectromechanical systems (MEMS) transducer but other types of transducers may be used alternatively. A direct current (DC) signal component is removed from the digital signal before converting the digital signal to a pulse density modulated (PDM) signal having an idle tone frequency that is approximately one-half a frequency at which at least a portion of the integrated circuit is clocked. The idle tone frequency is selectively offset by applying a DC offset to the digital signal after removing the DC signal component and before converting the digital signal into a PDM signal.

**[0021]** In another embodiment, a microphone device includes an acoustic microelectromechanical systems (MEMS) transducer configured to generate an analog signal responsive to an acoustic signal, and a signal processing circuit, coupled to the transducer. The signal processing circuit includes an analog-to-digital converter configured to convert the analog signal generated by the transducer to a digital signal. The signal processing circuit also includes a filter configured to remove a direct current (DC) signal component from the digital signal. The signal processing circuit also includes a DC offset circuit configured to apply a DC offset to the digital signal after the DC component is removed. The signal processing circuit also includes a digital-to-digital converter configured to convert the digital signal having the DC offset to a pulse density modulated (PDM) signal having an idle tone frequency that is approximately one-half a clock frequency provided to at least a portion of the signal processing circuit.

**[0022]** In an embodiment, an audio signal processing circuit for a microphone device includes an analog to digital converter configured to convert an analog signal received from an acoustic transducer to a digital signal. The signal processing circuit also includes a filter configured to remove a direct current (DC) signal component from the digital signal. The signal processing circuit further includes a DC offset circuit configured to apply a DC offset to the digital

signal after the DC signal component is removed. The signal processing circuit also includes a digital-to-digital converter configured to convert the digital signal to a 1-bit pulse density modulated (PDM) signal after the DC offset is applied to the digital signal, where the PDM signal has an idle tone frequency that is offset by the DC offset and the offset idle tone frequency is approximately one-half a clock frequency provided to at least a portion of the signal processing circuit.

**[0023]** FIG. 3 depicts a digital microphone device 300 including a transducer 304 and an electrical circuit 350 for processing acoustic signals and for removing or reducing noise caused by idle frequencies discussed above in relation to FIGS. 1 and 2. The electrical circuit 350 comprises a signal processing circuit 306, a high pass filter (HPF) 312, a DC value input 316, an adder 314, and a digital-to-digital converter (DDC) 308. In one or more embodiments, some or all of the signal processing circuit 306, the HPF 312, the adder 314, the DC value input 316, and the DDC 308 can be implemented in one or more integrated circuits, such as an application specific integrated circuit (ASIC), a programmable digital signal processor, or a combination thereof. The MEMS transducer 304 can convert acoustic energy into analog electrical signals. For example, the MEMS transducer 304 can generate an analog signal representing an acoustic energy incident on the MEMS transducer 304. The signal processing circuit 306 can include analog and/or digital circuitry such as, for example, amplifiers, filters, analog-to-digital converters, digital signal processor, and other electrical circuitry for processing the analog signals received from the MEMS transducer 304. For example, the signal processing circuit 306 can carry out analog signal amplification, analog filtering, and level shifting on the analog signals received from the MEMS transducer 304. Additional processing can include analog signal sampling, analog-to-digital conversion, digital filtering and other digital processing operations. A clock signal 382 can be provided to the electrical circuit 350. While the clock signal 382 is shown in FIG. 3 as being provided to the signal processing circuit 306, the clock signal 382 or multiples or divisions thereof can be provided to any component of the electrical circuit 350. Different clock signals may also be provided to different portions of the digital microphone device 300.

**[0024]** The signal processing circuit 306 can process the analog signal received from the MEMS transducer 304 and generate a multi-bit digital signal, where the number of bits representing the digital signal can be, for example, from 2-bits to 64-bits, or 20-bits. The signal processing circuit 306 can output the digital signal at a frequency that is a function of the frequency  $f_{clk}$  of the clock signal 382. For example, in one or more embodiments, the signal processing circuit 306 can output the digital signal at frequency that is equal to the clock frequency  $f_{clk}$ .

**[0025]** The HPF 312 receives the digital signal generated by the signal processing circuit 306 and filters the digital signal to generate a filtered digital signal. The HPF 312 is a high-pass filter, and attenuates frequency components of the digital signal that are below a cut-off frequency. The HPF 312 can have a cut-off frequency that is low enough to substantially attenuate, or completely remove, a direct-current (DC) component of the digital signal. For example, the cut-off frequency of the HPF 312 can be set at a few Hz, such as, for example, at about 5 Hz, or at about 10 Hz. Thus, the filtered digital signal output by the HPF 312 does not

include, or includes a highly attenuated, DC component. The HPF may be implemented as an infinite impulse response (IIR) filter, a finite impulse response (FIR) filter or as some other digital filter suitable for removing the DC component.

**[0026]** The filtered digital signal output by the HPF **312** is provided to the adder **314**. The adder **314** also receives a DC value from the DC value input **316**. The adder can add the DC value received from the DC value input **316** to the filtered digital signal received from the HPF **312**, and generate an offset digital signal. The adder **314** can include a digital adder that can add the DC value to the time sample values of the filtered digital signal.

**[0027]** The DDC **308** receives the offset digital signal from the adder **314**, and converts the offset digital signal into an encoded digital signal. The DDC **308** can include a digital-to-digital converter that can convert a multi-bit digital signal into another multi-bit or single-bit digital signal. In some such embodiments, the number of bits of the converted digital signal can be equal to or less than the number of bits of the input digital signal. For example, the input digital signal can be a 20-bit signal and the converted digital signal can be a 1-bit signal. In some other such implementations, the number of bits of the converted digital signal can be greater than the number of bits of the input digital signal. In one or more embodiments, the DDC **308** can include a digital encoder for converting the multi-bit digital signal. For example, a 1-bit pulse-density modulation (PDM) encoder can be used, which can convert a multi-bit pulse-code-modulation (PCM) digital signal into a corresponding stream of 1-bit digital signal. Thus, the output of the DDC **308** can be a 1-bit encoded digital signal.

**[0028]** The DDC **308** outputs the encoded digital signal onto a data interconnect **380**, which can be connected to a codec or a digital signal processor for further processing. The data interconnect may also be connected to another digital microphone device when, for example, the digital microphone device **300** is connected in stereo mode. In stereo mode, the encoded digital signals of both the digital microphone device **300** and the other digital microphone device can be provided to the digital signal processor or a codec via the data interconnect **380**. The two encoded digital signals can be time domain multiplexed over the data interconnect **380**. In time domain multiplexing, a first digital microphone device can be configured to output a first encoded digital signal on a first edge (rising or falling) edge of the clock signal **382**, while a second digital microphone device can be configured to output a second encoded digital signal on a second edge (falling or rising) of the clock signal **382**. Of course, other time domain multiplexing techniques, or other multiplexing techniques, also can be used. In some embodiments, the digital microphone device **300** can include an L/R input **310**, indicating the audio channel that the digital microphone device **300** is assigned to. For example, the L/R input **310** of the digital microphone device **300** being connected to a first voltage (e.g., supply voltage, VDD) can indicate that the digital microphone device **300** is assigned a left audio channel, while the L/R input **310** being connected to a second voltage (e.g., ground voltage, GND) can indicate that the digital microphone device **300** is assigned to a right audio channel.

**[0029]** The first idle tone frequency associated with the digital microphone device **300** can be a function of the clock frequency  $f_{clk}$  and a DC value of the digital signal encoded

by the first DDC. In some embodiments, this relationship can be given by the following Equation (1):

$$f_{idle-1} = \frac{f_{clk}}{2}(1 - DC) \quad (1)$$

where,  $f_{idle-1}$  denotes the idle tone frequency,  $f_{clk}$  denotes the clock frequency of the clock signal, and DC denotes the DC value (in reference to the digital full scale) of the digital signal provided to the DDC. In some implementations,  $f_{clk}$  can denote the sampling frequency of the 1-bit encoded digital signal output by the DDC **308**. By selecting a particular DC value, the idle tone frequency  $f_{idle-1}$  can be changed. The idle noise component **208**, shown in FIG. 2, is a result of the difference between the first idle tone frequency **104** and the second idle tone frequency **106**, shown in FIG. 1. The first idle tone frequency **104** shown in FIG. 1 can represent the idle tone frequency generated by the digital microphone device **300** of FIG. 3. Therefore, by changing the frequency of the first idle tone, the frequency of the noise component can be changed. The change in the frequency of the noise component is a function, in part, of the DC value. Therefore, an appropriate DC value can be selected such that the corresponding change in the frequency of the noise component is sufficient to move the noise component outside of the operational frequency range as discussed further herein.

**[0030]** FIG. 4 depicts a third plot **400** of first and second idle tones ( $f_{idle-1}$  and  $f_{idle-2}$ ) produced by two different microphone devices of the type shown in FIG. 3. FIG. 5 depicts a fourth plot **500** of an intermodulation frequency component resulting from mixing the idle tones shown in FIG. 4. The third plot **400** shows that the frequency of the first idle tone **404** is changed from  $f_{idle-1}$  to  $f'_{idle-1}$ . As a result, as shown in the fourth plot **500**, the frequency of the noise component **508**, which is an IM frequency, changes from  $f_{noise}$  to  $f'_{noise}$ , which is outside of the operational frequency range **510**.

**[0031]** Referring again to FIG. 3, the filtered digital signal output by the HPF **312** is substantially devoid of a DC signal component. The filtered digital signal is provided to the adder **314**, which adds a DC value provided by the DC value input **316** to the filtered digital signal to generate the offset digital signal. The offset digital signal is processed by the DDC **308** to generate the encoded digital signal, which includes an idle tone having a frequency  $f_{idle-1}$  that has been shifted relative to an idle tone frequency that would have been generated in the absence of the DC offset. In FIG. 4, the second idle tone **406** generated by a second digital microphone device will have a frequency  $f_{idle-2}$  at about one-half the clock frequency. As a result, with the appropriate selection of the DC value, the difference between the frequencies of the two idle tones will result in a noise component **508** that is outside of the operational frequency range **510**. By shifting the noise component **508** outside of the operational frequency range **510**, a signal-to-noise ratio of the signals generated by the digital microphone device can be improved.

**[0032]** FIG. 6 illustrates a system **600** including a left digital microphone device **602** and a right digital microphone device **604** connected in stereo mode. The left digital microphone device **602** and the right digital microphone device **604** can be devices that include a transducer and

processing circuitry to generate digital signals corresponding to incident audio energy. Each of the left digital microphone device **602** and the right digital microphone device **604** can be implemented as the digital microphone device shown in FIG. 3. The left digital microphone device **602** includes a left high pass filter (HPF) **616**, a left adder **606**, a left DC value input **608** and a left digital-to-digital converter (DDC) **610**. While not shown, the left digital microphone device **602** also includes an audio transducer (such as, for example, a MEMS transducer) and a signal processing circuit, which can process the signals generated by the audio transducer and generate a left digital signal **612** provided to the left HPF **616**. The right digital microphone device **604** includes a right HPF **654**, a right adder **656**, a right DC value input **658** and a right DDC **660**. While not shown, the right digital microphone device **604** also includes an audio transducer (such as, for example, a MEMS transducer) and a signal processing circuit, which can process the signals generated by the audio transducer and generate a right digital signal **652** provided to the right HPF **654**. The audio transducer and the signal processing circuits can be similar to the transducer and the signal processing circuit discussed above in relation to FIG. 3. The left DDC **610** can generate a left encoded digital signal **614**, while the right DDC **660** can generate a right encoded digital signal **664**. The left encoded digital signal and the right encoded digital signals can be time domain multiplexed on the data interconnect **675**.

**[0033]** Both the left digital microphone device **602** and the right digital microphone device **604** include an external device interface. In one embodiment, the external device interface includes a VDD terminal, a SEL (select) terminal, a GND terminal, a CLK (clock) terminal, and a SDO (digital output) terminal. The VDD terminal receives a power supply voltage, the GND terminal is connected to a ground voltage, the SEL terminal is connected to either VDD or GND based on whether the corresponding device is assigned to a left channel or a right channel (the SEL terminal can be coupled to the L/R input **310** discussed above in relation to FIG. 3). For example, the SEL terminal of the left digital microphone device **602** is coupled to VDD to assign it to the left channel, while the SEL terminal of the right digital microphone device **604** is coupled to GND to assign it to the right channel. The CLK terminal receives a clock signal, and the SDO terminal is coupled to a data interconnect **675**, which, in turn, is connected to additional processing circuitry such as a DSP and codec. In other embodiments, the interface may have other terminals or contacts depending on the interface protocol.

**[0034]** Each of the left digital microphone device **602** and the right digital microphone device **604** is capable of generating an offset encoded digital signal at its respective SDO terminal. In one or more embodiments, only one of the two microphone devices may generate an offset encoded digital signal. For example, if the left DC value input **608** is enabled to add a DC signal component to the left filtered digital signal, then the right DC value input **658** is disabled, such that the right filtered digital signal output by the right HPF **654** is fed to the right DDC **660** without having a DC signal component added to it (e.g., by adding a zero DC value input). Of course, in some embodiments, the right DC value input **658** can be enabled to add a DC signal component to the right filtered digital signal before being fed to the right DDC **660**, and the left DC value input **608** can be disabled,

such that the left filtered digital signal output by the left HPF **616** is fed to the left DDC **610** without having a DC signal component added to it (e.g., by adding a zero DC value input).

**[0035]** In some embodiments, the left SEL terminal and the right SEL terminal can be used to determine which of the left DC value input **608** and the right DC value input **658** is enabled. As discussed above, in the stereo mode, one of the left SEL terminal and the right SEL terminal is connected to VDD, while the other can be connected to GND. The DC value input of only that digital microphone device whose corresponding SEL is coupled to GND can be enabled. For example, in the system **600** shown in FIG. 6, the right DC value input **658** would be enabled because the right SEL terminal is coupled to GND, while the right SEL terminal is coupled to VDD. In some embodiments, DC value input of only that digital microphone device assigned to the right audio channel is enabled, while the DC value input for the digital microphone device assigned to the left channel is disabled. In some embodiments the reverse can be applied. The right offset digital signal generated by the right digital microphone device can be similar to the offset encoded signal generated by the DDC **308** discussed above in relation to FIG. 3, resulting in the noise signal being shifted outside of the operational frequency range of the system **600**.

**[0036]** In one or more embodiments, both the left DC value input **608** and the right DC value input **658** can be enabled such that both the left digital microphone device **602** and the right digital microphone device **604** generate respective offset encoded digital signals. In some such embodiments, the DC signal component added by the left DC value input **608** and the DC signal component added by the right DC value input **658** are selected to be unequal. Specifically, the difference in the values of these DC signal components can be selected such that the frequency of the resulting noise component is outside of the operational frequency range. That is, referring to FIGS. 4 and 5, the right DC value input **658** can output a DC component such that the second idle tone,  $f_{idle-2}$ , is also changed (in a manner similar to Equation (1) discussed above for changing  $f_{idle-1}$ ), such that changes in both the first and second idle tones contribute to the change in the frequency of the noise component **508**. In some implementations, the left DC value input **608** and the right DC value input **658** can be selected such that one adds a positive DC signal component while the other adds a negative DC signal component. This can result in the idle tone frequency associated with the left digital microphone device **602** to decrease and the idle tone frequency associated with the right digital microphone device **604** to increase, thereby increasing the frequency of the noise component to a value that is outside of the operational frequency range of the system **600**.

**[0037]** In one embodiment, the acoustic transducer is a condenser microphone implemented as a MEMS die. In other embodiments the transducer is a piezoelectric transducer implemented as a MEMS die or some other electro-mechanical transducer implemented using a known or future technology.

**[0038]** FIG. 7 illustrates a cross-sectional view of an example bottom-port digital microphone assembly **750** that can be used to implement a digital microphone device. In particular, the example digital microphone assembly **750** can

be used to implement the left digital microphone device 602 and the right digital microphone device 604 discussed above in relation to FIG. 6.

[0039] The digital microphone assembly 750 includes a substrate 722 and a cover or lid 716 disposed on the substrate 722 to form a housing. The housing encloses a MEMS transducer 720, and an integrated circuit (IC) 708. The MEMS transducer 720 includes a movable diaphragm positioned in close proximity to a back plate. The diaphragm is configured to move in relation to the back plate in response to incident acoustic energy, thereby changing a capacitance between the diaphragm and the back plate. The change in capacitance can be transformed into a change in the electrical signal such as a current or a voltage. The substrate 722 defines a sound port 724. Alternatively, the sound port may be formed in the cover. In either case the MEMS transducer 720 divides the volume of the housing into a front volume and a back volume. In bottom port devices, the front volume 726 opens to the outside of the digital microphone assembly 750 through the port 724. The back volume 728 is enclosed by a space enclosed by the cover 716. The port 724 allows acoustic energy to enter the front volume 726 and be incident on the MEMS transducer 720, which transforms the incident acoustic energy into corresponding electrical signals. The electrical signals generated by the MEMS transducer 720 can be processed by the IC 708, which can include analog and digital circuitry discussed above with referenced to FIG. 3. The digital microphone assembly 750 also can include an external device interface including one or more terminals (such as the terminals discussed above in relation to FIG. 6). The terminals can be implemented using pins, bonding pads, wires, and other electrical connectors. The external device interface includes contacts or terminals formed on the substrate 722 or cover 716. The terminals are coupled to components inside the digital microphone assembly 750 by electrical conductors.

[0040] FIG. 8 shows a flow diagram of an example process 800 used for reducing idle tone frequency noise. The process 800 includes converting an analog signal output by an acoustic transducer into a digital signal (stage 802). For example, as shown in FIG. 3, the signal processing circuit 306 converts the analog signal output by the MEMS transducer 304 into a digital signal. The method also includes removing a direct current (DC) signal component from the digital signal (stage 804). For example, as shown in FIG. 3, the HPF 312 filters or removes a DC component from the digital signal output by the signal processing circuit 306.

[0041] The process 800 also includes after removing the DC signal component, converting the digital signal to a pulse density modulated (PDM) signal having an idle tone frequency that is approximately one-half of a clock frequency (stage 806). For example, as shown in FIG. 3, the DDC 308 converts the filtered digital signal output by the HPF 312 into an encoded digital signal using pulse-density modulation. Further, as shown in FIG. 4, the encoded digital signal includes a first idle tone 404 having a frequency  $f_{idle-1}$ , which is approximately equal to one-half of the clock frequency  $f_{clk}$ .

[0042] The process additionally includes offsetting the idle tone frequency by applying a DC offset to the digital signal after removing the DC signal component and before converting the digital signal into a PDM signal, where the difference in the idle tone frequency before and after apply-

ing the DC offset is greater than a predetermined bandwidth (stage 808). One example of this process stage has been discussed above in relation to FIGS. 3-5. For example, as shown in FIG. 3, the adder 314 adds a DC value to the filtered digital signal output by the HPF 312 before the filtered digital signal is converted into the encoded digital signal by the DDC 308. As shown in FIG. 4, by adding the DC value, the frequency of the first idle tone 404 is shifted from  $f_{idle-1}$  to  $f_{idle}$ . This, in turn results in the shifting of the frequency of the noise component 508 from  $f_{noise}$  to  $f'_{noise}$  as shown in FIG. 5. The change in the frequency of the first idle tone 404 is selected to be such that it is sufficient to move the frequency of the noise component 508 to outside of the desired operational frequency range 510. In some embodiments, the shift in the frequency of the first idle tone 404 can be approximately equal to the operational frequency range 510. As mentioned above, in some embodiments, the operational frequency range can be equal to the human audible frequency range. In other embodiments however the operational frequency range extends beyond the human audible frequency range, for example, in applications where ultrasonic signals are used.

[0043] FIG. 9 depicts example test data 900 showing an attenuation of a noise component in a digital microphone system when used in the stereo mode (i.e., a “left” and a “right” microphones are connected in a manner illustrated in FIG. 6). In particular, the test data 900 shows a first power spectral density (PSD) waveform 902 and a second PSD waveform 904 within a frequency range of about 100 Hz to about 2 kHz. The first and second PSD waveforms 902 and 904 represent the PSD of an encoded digital signal output by a digital converter, such as the encoded digital signal output by the DDC 308 (FIG. 3). The first PSD waveform 902 represents the PSD of the encoded digital signal when no DC offset, such as the DC value input 316, is applied the digital signal converted by the digital converter. The second PSD waveform 904 represents the PSD of the encoded digital signal when a DC value provided, for example, by the DC value input 316, is added to the digital signal. The resulting reduction in the noise component due to idle tones is reflected in the reduction in the PSD of the second PSD waveform 904 in relation to that of the first PSD waveform 902. For example, at about 200 Hz, a reduction in the PSD of about 8 dB can be observed.

[0044] In one aspect, this disclosure describes a method in a digital microphone assembly including an acoustic microelectromechanical systems (MEMS) transducer and an integrated circuit. The method includes converting an analog signal output by the acoustic transducer to a digital signal. The method also includes removing a direct current (DC) signal component from the digital signal. The method further includes, after removing the DC signal component, converting the digital signal to a pulse density modulated (PDM) signal having an idle tone frequency that is approximately one-half a frequency at which at least a portion of the integrated circuit is clocked. The method also includes offsetting the idle tone frequency by applying a DC offset to the digital signal after removing the DC signal component and before converting the digital signal into a PDM signal.

[0045] In some embodiments, the method can also include offsetting the idle tone frequency in response to a signal indicating that the microphone assembly is being used in stereo mode, and not offsetting the idle tone frequency absent the signal indicating that the microphone assembly is

being used in stereo mode. In some embodiments, the acoustic transducer and the integrated circuit are disposed in a housing of the microphone assembly, wherein receiving the signal indicating that the microphone assembly is being used in stereo mode is receivable via an external device interface of the microphone assembly. In some embodiments, converting the digital signal into a PDM signal includes converting the digital signal into a 1-bit PDM signal. In some embodiments, a difference between the idle tone frequency with and without the DC offset is greater than a human audible range of frequencies. In some embodiments, converting the analog signal output by the acoustic transducer to the digital signal includes converting the analog signal using a multi-bit converter. In some embodiments, removing the direct current (DC) signal component from the digital signal includes filtering the digital signal with a high-pass filter.

**[0046]** In some aspects, this disclosure describes a microphone device. The microphone device includes an acoustic microelectromechanical systems (MEMS) transducer configured to generate an analog signal responsive to an acoustic signal. The microphone device also includes a signal processing circuit coupled to the transducer. The signal processing circuit includes an analog-to-digital converter configured to convert the analog signal generated by the transducer to a digital signal. The signal processing circuit also includes a filter configured to remove a direct current (DC) signal component from the digital signal. The signal processing circuit further includes a DC offset circuit configured to apply a DC offset to the digital signal after the DC component is removed. The signal processing circuit further includes a digital-to-digital converter configured to convert the digital signal having the DC offset to a pulse density modulated (PDM) signal having an idle tone frequency that is approximately one-half a clock frequency of at least a portion of the signal processing circuit, where the idle tone frequency is offset by the DC offset applied to the digital signal.

**[0047]** In some embodiments, the signal processing circuit is further configured to apply the DC offset in response to receiving a signal indicating that the microphone device is being used in stereo mode, and not apply the DC offset absent the signal indicating that the microphone device is being used in stereo mode. In some embodiments, the transducer and the signal processing circuit are disposed in a housing including a surface mount external-device interface wherein the signal indicating that the microphone device is being used in stereo mode is receivable via the external device interface. In some embodiments, the PDM signal is a 1-bit PDM signal. In some embodiments, a difference between the offset idle tone frequency and an idle tone frequency that would be produced without the DC offset is greater than a bandwidth corresponding to a range of human audible frequencies. In some embodiments, the analog-to-digital converter is a multi-bit converter. In some embodiments, the filter is a high pass filter.

**[0048]** In some aspects, this disclosure discusses an audio signal processing circuit for a microphone device. The circuit includes an analog to digital converter configured to convert an analog signal received from an acoustic transducer to a digital signal. The circuit further includes a filter configured to remove a direct current (DC) signal component from the digital signal. The circuit also includes a DC offset circuit configured to apply a DC offset to the digital

signal after the DC signal component is removed. The circuit further includes a digital-to-digital converter configured to convert the digital signal to a 1-bit pulse density modulated (PDM) signal after the DC offset is applied to the digital signal, where the PDM signal has an idle tone frequency that is offset by the DC offset and the offset idle tone frequency is approximately one-half a clock frequency of the digital-to-digital converter.

**[0049]** In some embodiments, the signal processing circuit is further configured to selectively apply the DC offset to the digital signal in response to receiving a selection signal. In some embodiments, the PDM signal is a 1-bit PDM signal. In some embodiments, a difference between the offset idle tone frequency and an idle tone frequency that would be produced without the DC offset is greater than a bandwidth corresponding to a range of human audible frequencies. In some embodiments, the analog-to-digital converter is a multi-bit converter. In some embodiments, the filter is a high pass filter.

**[0050]** The foregoing description of illustrative embodiments has been presented for purposes of illustration and of description. It is not intended to be exhaustive or limiting with respect to the precise form disclosed, and modifications and variations are possible in light of the above teachings or may be acquired from practice of the disclosed embodiments. It is intended that the scope of the invention be defined by the claims appended hereto and their equivalents.

What is claimed is:

1. A system comprising:

a first microphone assembly comprising a first microelectromechanical systems (MEMS) transducer and a first integrated circuit, the first integrated circuit configured to:

convert a first analog signal produced by the first MEMS transducer to a first digital signal;

convert the first digital signal to a first pulse density modulated (PDM) signal to generate a first digital microphone output signal; and

provide the first digital microphone output signal on a common interface; and

a second microphone assembly comprising a second MEMS transducer and a second integrated circuit, the second integrated circuit configured to:

convert a second analog signal produced by the second MEMS transducer to a second digital signal;

remove a direct current (DC) signal component from the second digital signal;

apply a DC offset to the second digital signal to affect an idle tone frequency of the second digital signal;

convert the second digital signal to a second PDM signal to generate a second digital microphone output signal; and

provide the second digital microphone output signal on the common interface.

2. The system of claim 1, wherein the first integrated circuit is configured to generate the first digital microphone output without applying a DC offset to the first digital signal.

3. The system of claim 1, wherein the second integrated circuit is configured to apply the DC offset to the second digital signal responsive to receiving a select signal on an external device interface of the second microphone assembly.

4. The system of claim 1, wherein a value of the DC offset applied to the second digital signal is adjustable, and

wherein the value of the DC offset applied to the second digital signal depends on a sampling frequency associated with the second PDM signal.

5. The system of claim 1, wherein the second digital microphone output signal comprises a single bit PDM signal, and wherein the second integrated circuit is configured to apply the DC offset to the second digital signal before converting the second digital signal to the second PDM signal.

6. The system of claim 1, wherein the second integrated circuit is configured to apply the DC offset to the second digital signal only when the second integrated is configured to provide the second digital microphone output signal on the common interface at a same time as the first integrated circuit is configured to provide the first digital microphone output signal on the common interface.

7. The system of claim 1, wherein a value of the DC offset applied to the second digital signal is adjustable, and wherein the value of the DC offset applied to the second digital signal depends on a clock frequency associated with the second integrated circuit.

8. The system of claim 1, wherein a combined idle tone frequency of the first digital microphone output signal and the second digital microphone output signal on the common interface is outside of a human audible frequency range.

9. A microphone assembly comprising:

a micro electromechanical systems (MEMS) transducer configured to generate an analog signal responsive to an acoustic signal; and

an integrated circuit coupled to the MEMS transducer and configured to:

convert the analog signal to a digital signal;

remove a direct current (DC) signal component from the digital signal;

apply a DC offset to the digital signal to affect an idle tone frequency of the digital signal;

convert the digital signal to a PDM signal to generate a digital microphone output signal.

10. The microphone assembly of claim 9, wherein the integrated circuit is configured to apply the DC offset to the digital signal responsive to receiving a select signal on an external device interface of the microphone assembly.

11. The microphone assembly of claim 9, wherein the integrated circuit is configured to apply the DC offset to the digital signal based on a mode of operation associated with the microphone assembly.

12. The microphone assembly of claim 9, wherein a value of the DC offset applied to the digital signal is adjustable, and wherein the value of the DC offset applied to the digital signal depends on a sampling frequency associated with the PDM signal.

13. The microphone assembly of claim 9, wherein a value of the DC offset applied to the digital signal is adjustable, and wherein the value of the DC offset applied to the digital signal depends on a clock frequency associated with the integrated circuit.

14. The microphone assembly of claim 9, wherein the integrated circuit is configured to apply the DC offset to the digital signal responsive to receiving a select signal on an external device interface of the microphone assembly.

15. A method in a microphone assembly comprising a microelectromechanical systems (MEMS) transducer and an integrated circuit, the method comprising:

converting an analog signal produced by the MEMS transducer to a digital signal;

removing a direct current (DC) signal component from the digital signal;

applying a DC offset to the digital signal to affect an idle tone frequency of the digital signal; and

converting the digital signal to a pulse density modulated (PDM) signal after applying the DC offset to the digital signal to generate a digital microphone output signal.

16. The method of claim 15, wherein applying the DC offset to the digital signal comprises applying the DC offset to the digital signal responsive to receiving a select signal on an external device interface of the microphone assembly.

17. The method of claim 15, wherein applying the DC offset to the digital signal comprises applying the DC offset to the digital signal in accordance with a value that depends on a sampling frequency associated with the PDM signal.

18. The method of claim 15, wherein applying the DC offset to the digital signal comprises applying the DC offset to the digital signal in accordance with a value that depends on a clock frequency associated with the integrated circuit.

19. The method of claim 15, wherein applying the DC offset to the digital signal comprises applying the DC offset to the digital signal based on a mode of operation associated with the microphone assembly.

20. The method of claim 15, wherein converting the digital signal to the PDM signal comprises generating a single bit PDM signal.

\* \* \* \* \*