



(19) **United States**

(12) **Patent Application Publication**  
**Henshaw et al.**

(10) **Pub. No.: US 2024/0066597 A1**

(43) **Pub. Date: Feb. 29, 2024**

(54) **METHODS OF ADDITIVELY MANUFACTURING A MANUFACTURED COMPONENT AND SYSTEMS THAT PERFORM THE METHODS**

(52) **U.S. CI.**  
CPC ..... **B22F 10/36** (2021.01); **B22F 12/30** (2021.01); **B22F 12/40** (2021.01); **B22F 12/50** (2021.01); **B33Y 10/00** (2014.12); **B33Y 30/00** (2014.12); **B33Y 40/00** (2014.12); **B33Y 50/02** (2014.12)

(71) Applicant: **The Boeing Company**, Chicago, IL (US)

(72) Inventors: **Dana Alexander Henshaw**, Seattle, WA (US); **Eric M. Chapman**, Bonney Lake, WA (US)

(21) Appl. No.: **17/895,870**

(22) Filed: **Aug. 25, 2022**

**Publication Classification**

(51) **Int. Cl.**  
**B22F 10/36** (2006.01)  
**B22F 12/30** (2006.01)  
**B22F 12/40** (2006.01)  
**B22F 12/50** (2006.01)  
**B33Y 10/00** (2006.01)  
**B33Y 30/00** (2006.01)  
**B33Y 40/00** (2006.01)

(57) **ABSTRACT**

Methods of additively manufacturing a manufactured component and systems that perform the methods. The methods include determining an energy application parameter at an addition location on a previously formed portion of the manufactured component. The methods also include supplying a feedstock material to the addition location. The methods further include delivering, from an energy source and to the addition location, an amount of energy sufficient to form a melt pool of the feedstock material at the addition location. The amount of energy is based, at least in part, on the energy application parameter. The methods also include consolidating the melt pool with a previously formed portion to form an additional portion of the manufactured component. The delivering includes delivering the amount of energy to the addition location along an axis of incidence, and the energy application parameter includes a directionality parameter that is based on the axis of incidence.

10

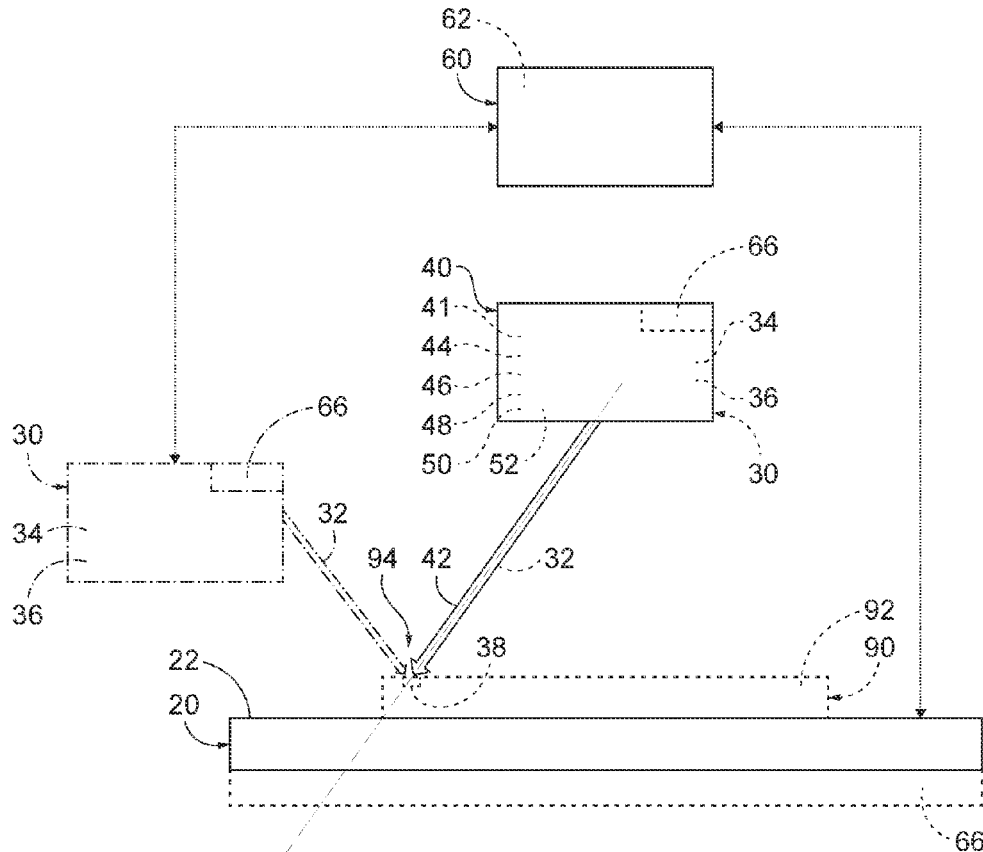

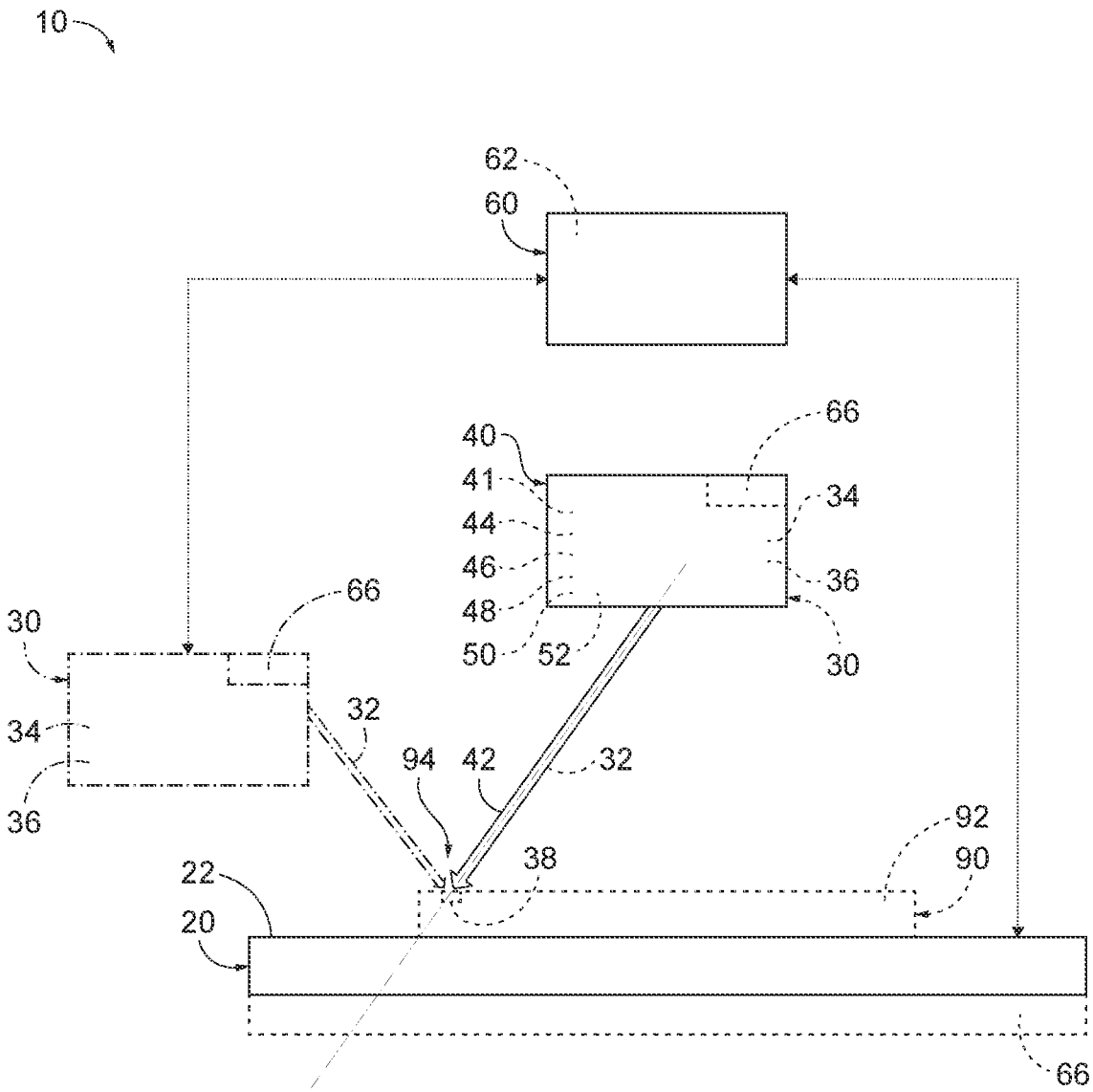

FIG. 1

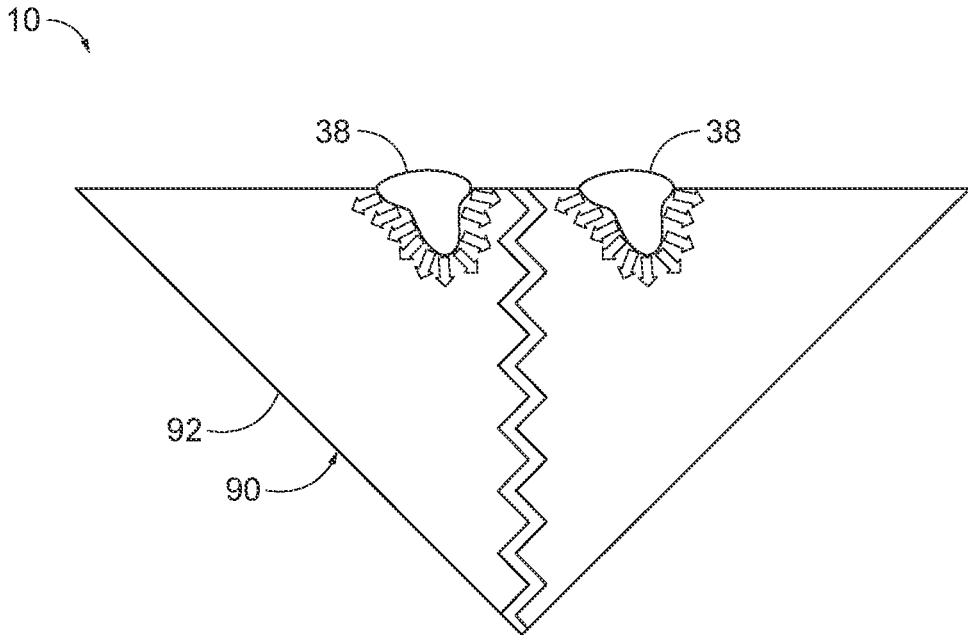

FIG. 2

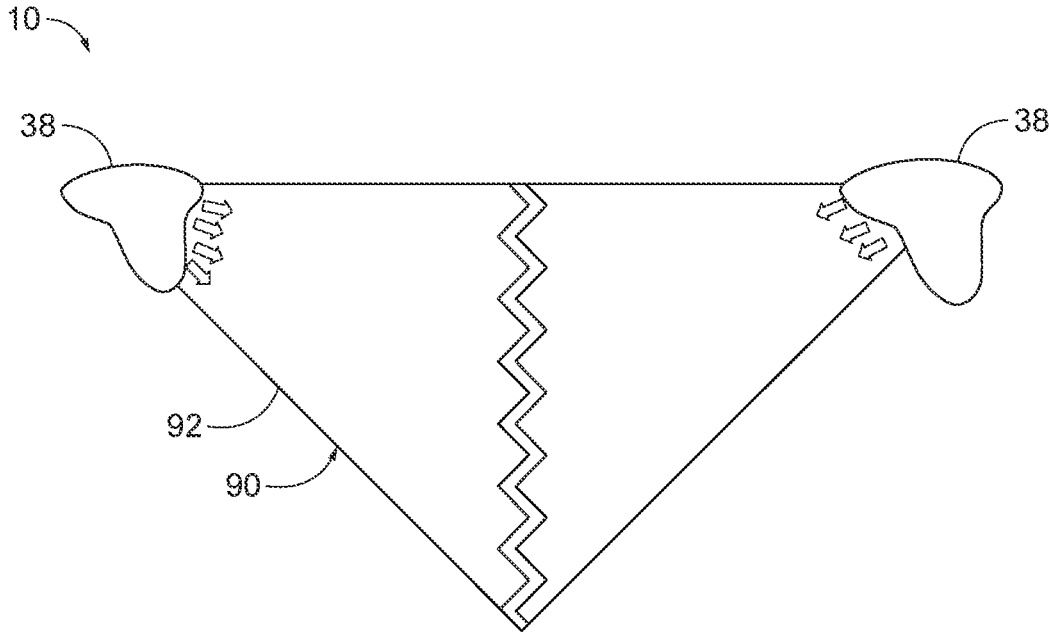

FIG. 3

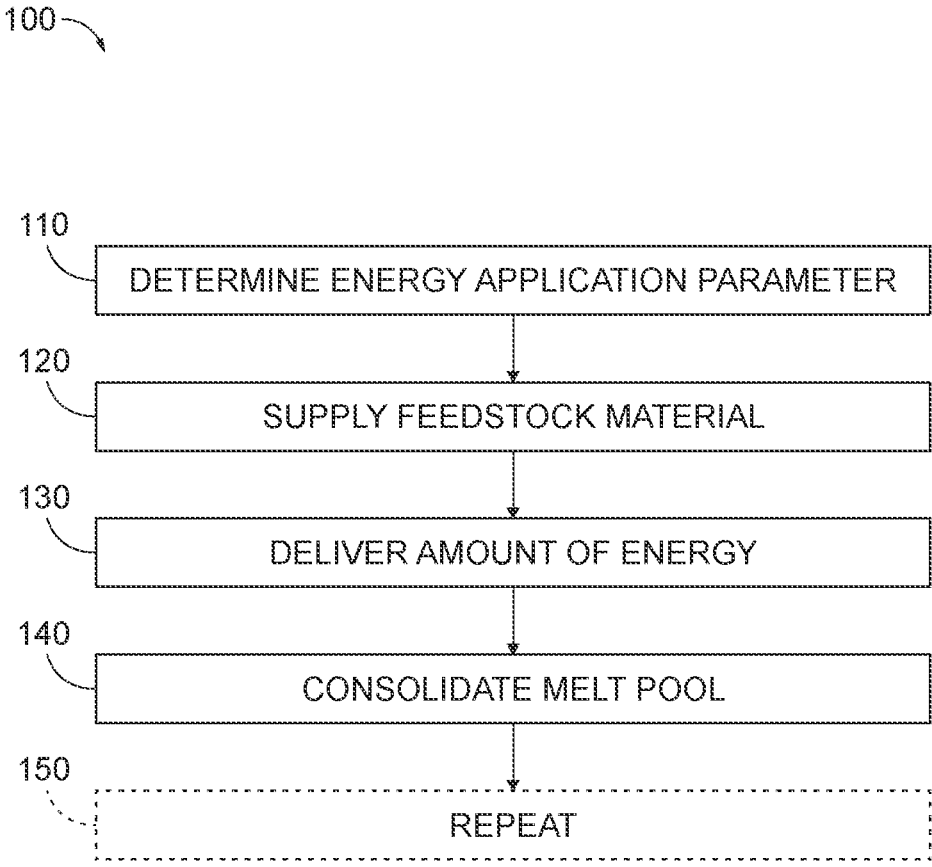

FIG. 4

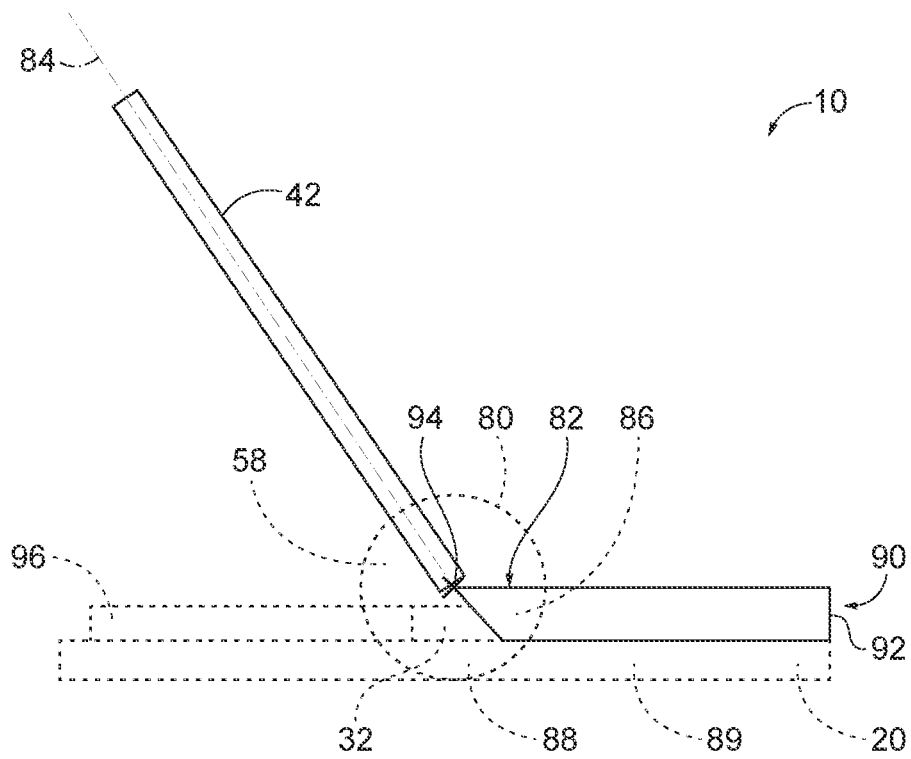

FIG. 5

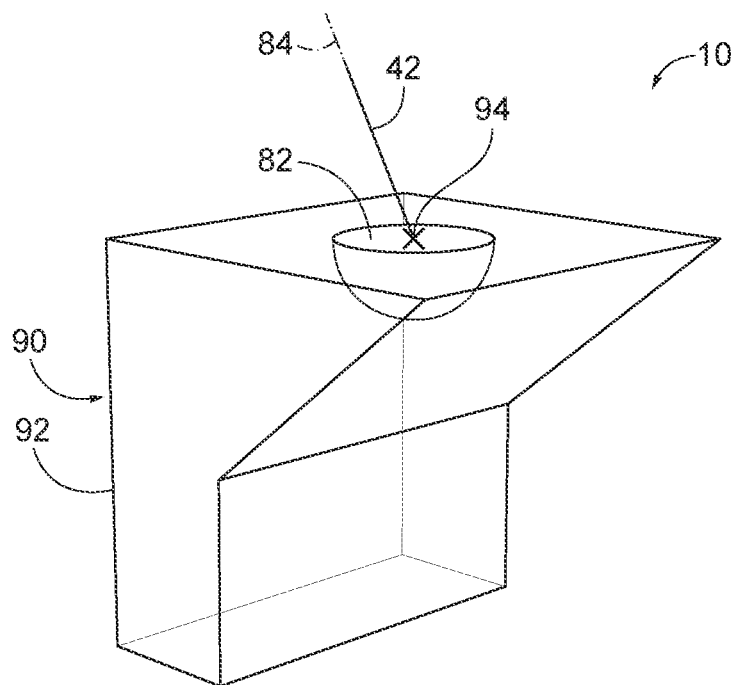

FIG. 6

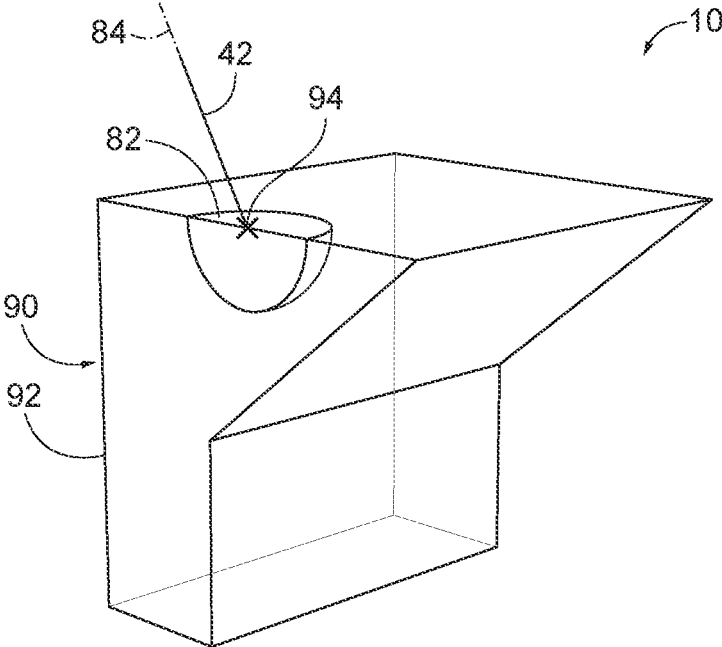

FIG. 7

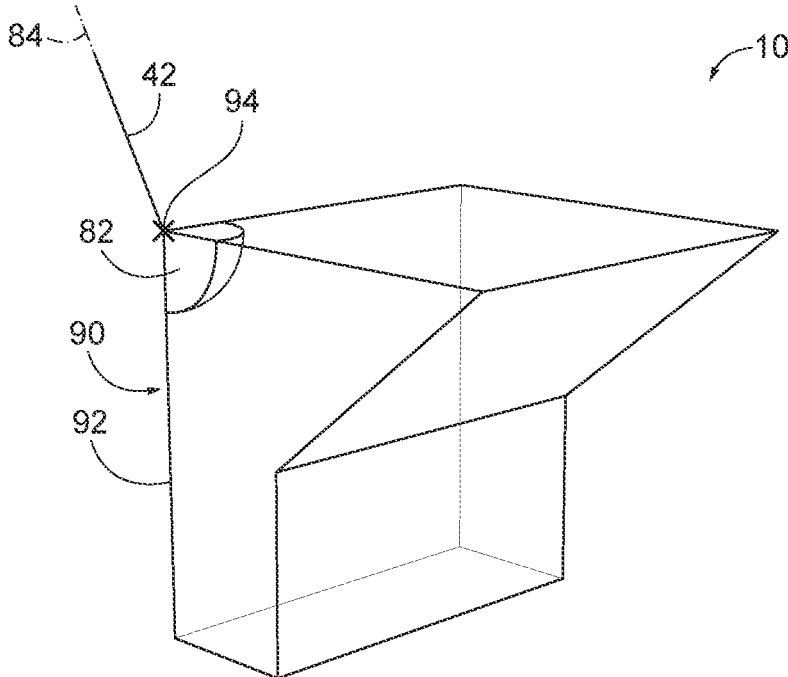

FIG. 8

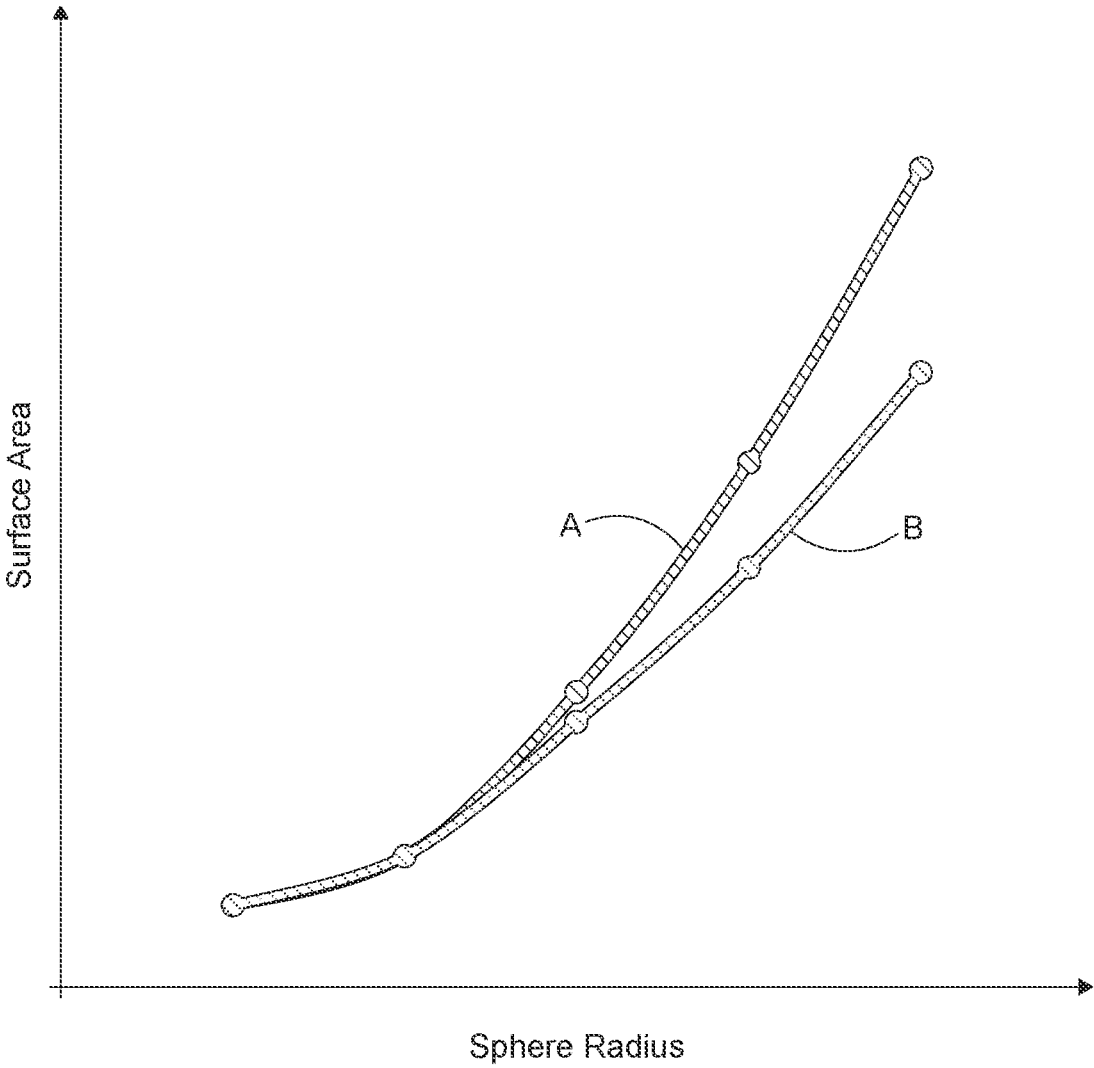

FIG. 9

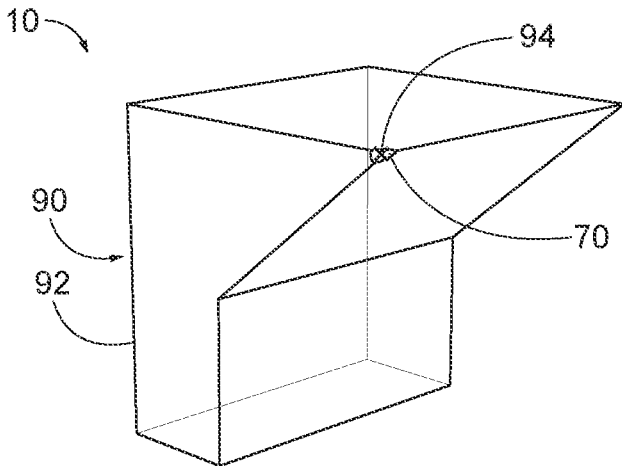

FIG. 10

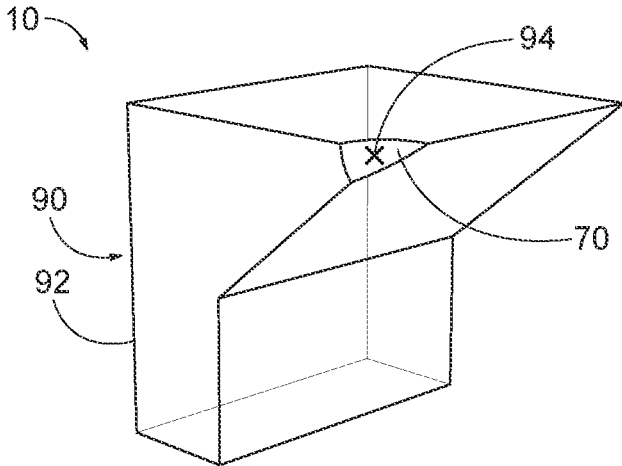

FIG. 11

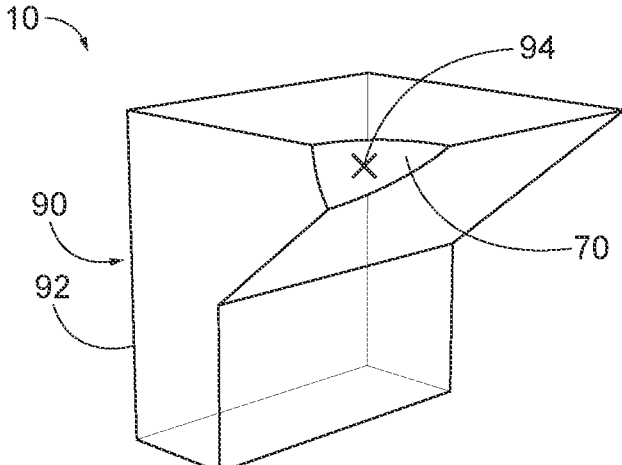

FIG. 12



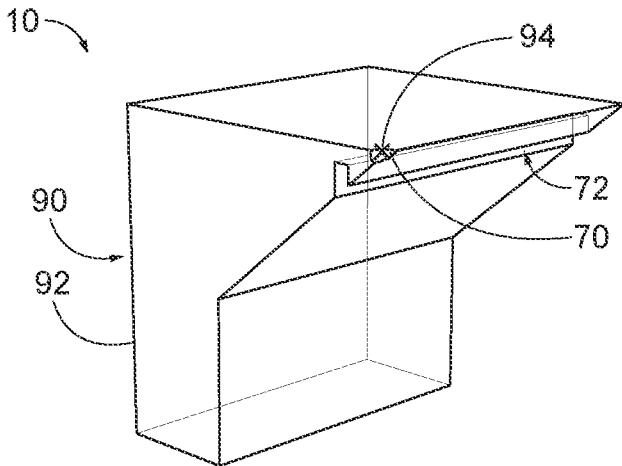

FIG. 13

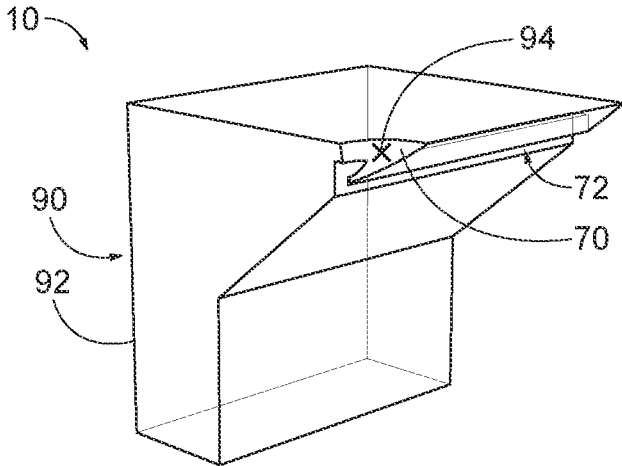

FIG. 14

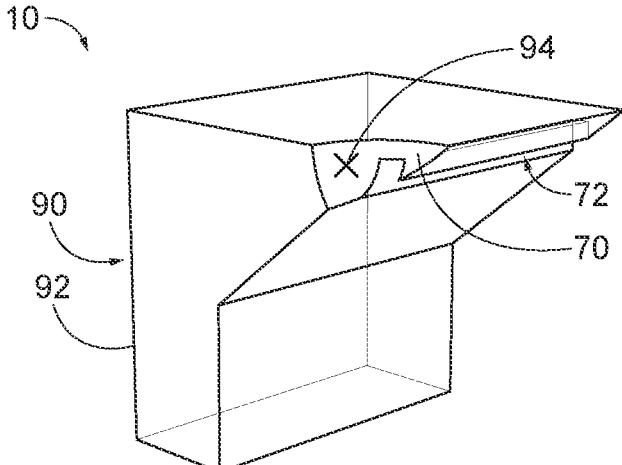

FIG. 15

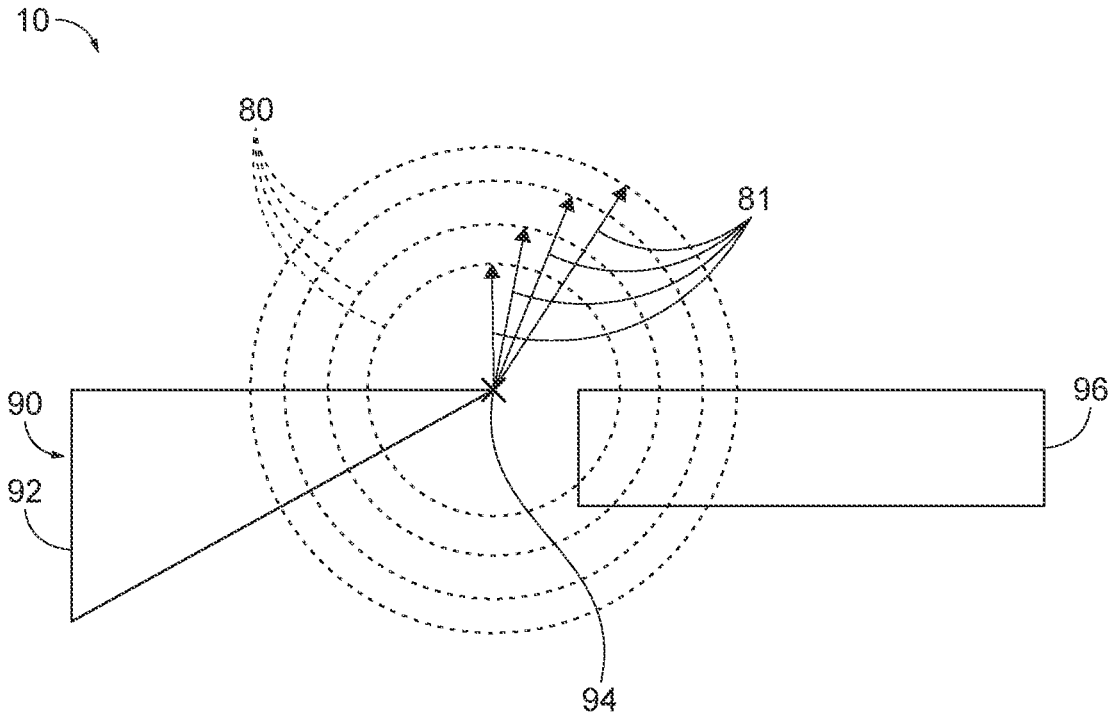

FIG. 16



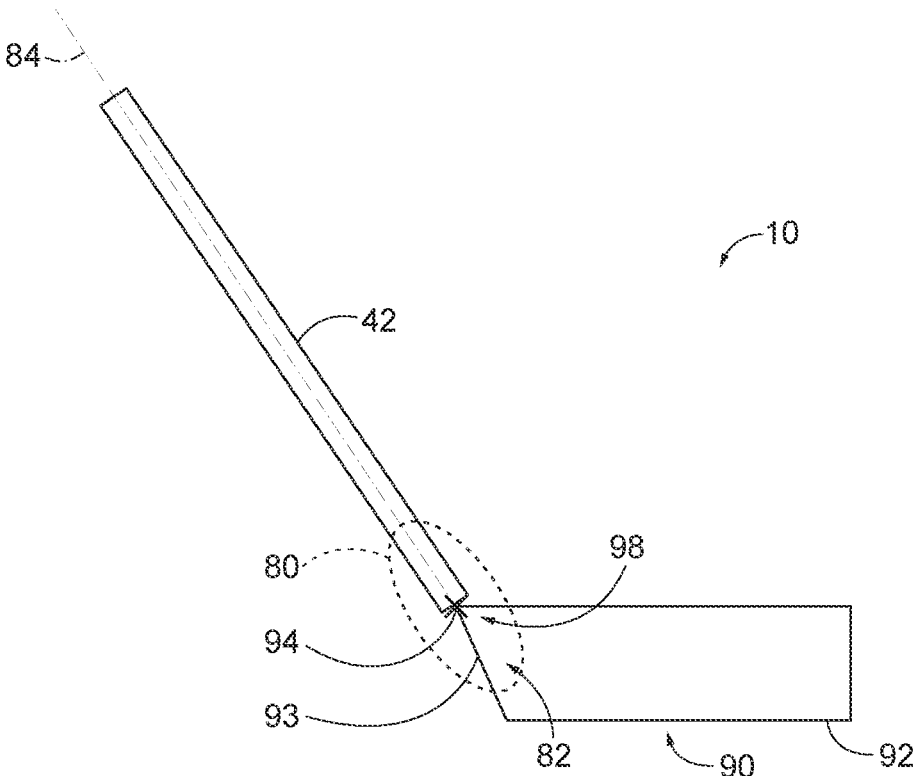

FIG. 19

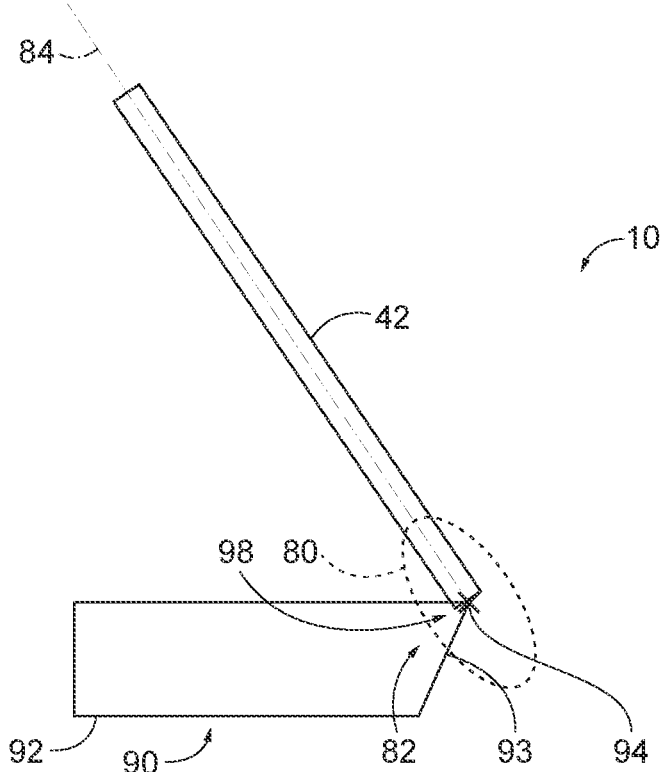

FIG. 20

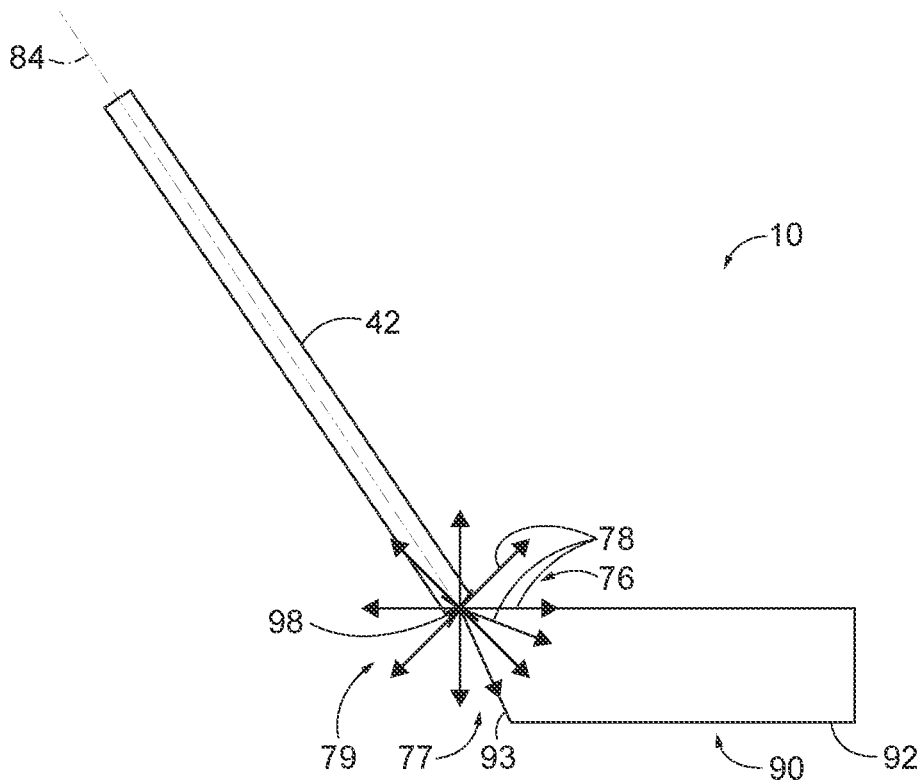

FIG. 21

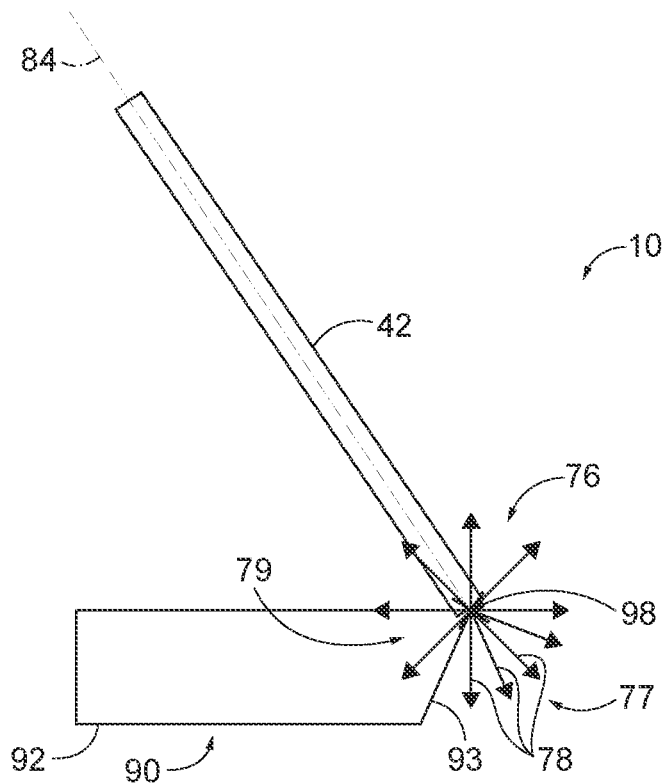

FIG. 22

**METHODS OF ADDITIVELY  
MANUFACTURING A MANUFACTURED  
COMPONENT AND SYSTEMS THAT  
PERFORM THE METHODS**

**FIELD**

**[0001]** The present disclosure relates generally to methods of additively manufacturing a manufactured component, to systems that perform the methods, and/or to storage media that direct systems to perform the methods.

**BACKGROUND**

**[0002]** Additive manufacturing processes generally utilize a form of energy input to consolidate a feedstock material into a manufactured component. In such additive manufacturing processes, an amount of energy needed to consolidate the feedstock material may vary with location within the manufactured component. As such, too much energy may be applied in some areas and/or too little energy may be applied in other areas, which may produce non-uniformities within the manufactured component. Thus, there exists a need for improved methods of additively manufacturing a manufactured component and/or for improved systems that perform the methods.

**SUMMARY**

**[0003]** Methods of additively manufacturing a manufactured component and systems that perform the methods are disclosed herein. The methods include determining an energy application parameter at an addition location on a previously formed portion of the manufactured component. The methods also include supplying a feedstock material to the addition location. The methods further include delivering, from an energy source and to the addition location, an amount of energy sufficient to form a melt pool of the feedstock material at the addition location. The amount of energy is based, at least in part, on the energy application parameter. The methods also include consolidating the melt pool with a previously formed portion of the manufactured component to form an additional portion of the manufactured component. The delivering includes delivering the amount of energy to the addition location along an axis of incidence, and the energy application parameter includes a directionality parameter that is based, at least in part, on the axis of incidence.

**[0004]** The systems include a support platform, which is configured to support the manufactured component during additive manufacture of the manufactured component. The systems also include a feedstock supply system, which is configured to supply the feedstock material to the addition location of the manufactured component. The systems further include an energy source, which is configured to deliver the amount of energy to the addition location. The systems also include a controller, which is programmed to control the operation of the systems according to the methods.

**BRIEF DESCRIPTION OF THE DRAWINGS**

**[0005]** FIG. 1 is a schematic illustration of examples of additive manufacturing systems, according to the present disclosure.

**[0006]** FIG. 2 is a schematic illustration of examples of additive manufacturing of a manufactured component, according to the present disclosure.

**[0007]** FIG. 3 is a schematic illustration of examples of additive manufacturing of a manufactured component, according to the present disclosure.

**[0008]** FIG. 4 is a flowchart depicting examples of methods of additively manufacturing a manufactured component, according to the present disclosure.

**[0009]** FIG. 5 is a schematic illustration of an example of an overlap volume that may be utilized with methods, according to the present disclosure.

**[0010]** FIG. 6 is a schematic illustration of an example of an overlap volume that may be utilized with methods, according to the present disclosure.

**[0011]** FIG. 7 is a schematic illustration of an example of an overlap volume that may be utilized with methods, according to the present disclosure.

**[0012]** FIG. 8 is a schematic illustration of an example of an overlap volume that may be utilized with methods, according to the present disclosure.

**[0013]** FIG. 9 is an illustration of an intersection relationship that may be utilized with methods, according to the present disclosure.

**[0014]** FIG. 10 is a schematic illustration of generation of an intersection relationship that may be utilized with methods, according to the present disclosure.

**[0015]** FIG. 11 is a schematic illustration of generation of an intersection relationship that may be utilized with methods, according to the present disclosure.

**[0016]** FIG. 12 is a schematic illustration of generation of an intersection relationship that may be utilized with methods, according to the present disclosure.

**[0017]** FIG. 13 is a schematic illustration of generation of an intersection relationship that may be utilized with methods, according to the present disclosure.

**[0018]** FIG. 14 is a schematic illustration of generation of an intersection relationship that may be utilized with methods, according to the present disclosure.

**[0019]** FIG. 15 is a schematic illustration of generation of an intersection relationship that may be utilized with methods, according to the present disclosure.

**[0020]** FIG. 16 is a schematic illustration of generation of an intersection relationship that may be utilized with methods, according to the present disclosure.

**[0021]** FIG. 17 is a schematic illustration of a directionality parameter that may be utilized with methods, according to the present disclosure.

**[0022]** FIG. 18 is a schematic illustration of a directionality parameter that may be utilized with methods, according to the present disclosure.

**[0023]** FIG. 19 is a schematic illustration of a directionality parameter that may be utilized with methods, according to the present disclosure.

**[0024]** FIG. 20 is a schematic illustration of a directionality parameter that may be utilized with methods, according to the present disclosure.

**[0025]** FIG. 21 is a schematic illustration of a directionality parameter that may be utilized with methods, according to the present disclosure.

**[0026]** FIG. 22 is a schematic illustration of a directionality parameter that may be utilized with methods, according to the present disclosure.

**DESCRIPTION**

**[0027]** FIGS. 1-22 provide illustrative, non-exclusive examples of additive manufacturing systems and/or of meth-

ods **100**, according to the present disclosure. Elements that serve a similar, or at least substantially similar, purpose are labeled with like numbers in each of FIGS. **1-22**, and these elements may not be discussed in detail herein with reference to each of FIGS. **1-22**. Similarly, all elements may not be labeled in each of FIGS. **1-22**, but reference numerals associated therewith may be utilized herein for consistency. Elements, components, and/or features that are discussed herein with reference to one or more of FIGS. **1-22** may be included in and/or utilized with any of FIGS. **1-22** without departing from the scope of the present disclosure.

**[0028]** In general, elements that are likely to be included in a given (i.e., a particular) embodiment are illustrated in solid lines, while elements that are optional to a given embodiment are illustrated in dashed lines. However, elements that are shown in solid lines are not essential to all embodiments, and an element shown in solid lines may be omitted from a particular embodiment without departing from the scope of the present disclosure.

**[0029]** FIG. **1** is a schematic illustration of examples of additive manufacturing systems **10**, according to the present disclosure. Additive manufacturing systems **10** may be configured to additively manufacture a manufactured component **90**. As illustrated in FIG. **1**, additive manufacturing systems **10** include a support platform **20**, a feedstock supply system **30**, and energy source **40**, and a controller **60**. Support platform **20** may be configured to support manufactured component **90** during additive manufacture of the manufactured component. Stated differently, support platform **20** may be configured to support manufactured component **90** during an additive manufacturing process that manufactures manufactured component **90**. Example of support platform **20** include a build plate and/or another structure that is configured to provide physical support for manufactured component **90**. In some examples, support platform **20** may include and/or define a support surface **22** upon which manufactured component **90** may be supported, formed, and/or defined during the additive manufacturing process.

**[0030]** Feedstock supply system **30** may be configured to supply a feedstock material **32** to an addition location **94** of manufactured component **90**. Examples of feedstock supply system **30** include a powder supply system **34**, which is configured to supply feedstock material **32** in the form of a feedstock material powder, and/or a filament supply system **36**, which is configured to supply feedstock material **32** in the form of a feedstock material filament.

**[0031]** Energy source **40** may be configured to deliver an amount of energy **42** to addition location **94**. Examples of energy source **40** include an electrical power source **44**, a source of electromagnetic radiation **46**, a laser beam source **48**, an electron beam source **50**, and/or a heat source **52**. In some examples of additive manufacturing systems **10**, and as illustrated in dashed lines in FIG. **1**, energy source **40** may be configured to provide amount of energy **42** to addition location **94** in and/or within feedstock material **32**. Examples of such additive manufacturing systems **10** include wire feed directed energy deposition, fused deposition modeling, wire arc additive manufacturing, directed energy deposition, and/or powder feed directed energy deposition. In some examples of additive manufacturing systems **10**, and as illustrated in dash-dot lines in FIG. **1**, energy source may be configured to provide amount of energy **42** to addition location **94** separately from feedstock material **32**.

Examples of such additive manufacturing systems **10** include laser powder bed fusion and/or electron beam powder bed fusion. In such examples, energy source **40** also may be referred to herein as and/or may include an energy delivery mechanism **41**.

**[0032]** As illustrated in dashed lines in FIG. **1**, systems **10** may include an actuation assembly **66**. Actuation assembly **66**, when present, may be adapted, configured, designed, and/or constructed to move support platform **20**, to move at least one component of feedstock supply system **30**, and/or to move at least one component of energy source **40**, such as to permit and/or to facilitate motion of addition location **94** relative to support surface **22** of support platform **20**. As an example, actuation assembly **66** may be associated with support platform **20** and/or may be configured to move support platform **20** relative to both feedstock supply system **30** and energy source **40**. As another example, actuation assembly **66** may be associated with feedstock supply system **30** and/or may be configured to cause feedstock supply system **30** to vary a location at which feedstock material **32** approaches and/or contacts previously formed portion **92**. As yet another example, actuation assembly **66** may be associated with energy source **40** and/or may be configured to cause energy source **40** to vary a location at which amount of energy **42** approaches and/or is incident upon previously formed portion **92**. Examples of actuation assembly **66** include any suitable electric actuator, mechanical actuator, hydraulic actuator, pneumatic actuator, linear actuator, rotary actuator, servo motor, stepper motor, rack and pinion assembly lead screw assembly, ball screw assembly, and/or piezoelectric actuator.

**[0033]** Controller **60** is programmed to control the operation of at least one other component of additive manufacturing system **10**. This may include controlling the operation of the at least one other component according to and/or by performing any suitable step and/or steps of methods **100**, which are discussed in more detail herein. Controller **60** may include and/or be any suitable structure, device, and/or devices that may be adapted, configured, designed, constructed, and/or programmed to perform the functions discussed herein. As examples, controller **60** may include one or more of an electronic controller, a dedicated controller, a special-purpose controller, a personal computer, a special-purpose computer, a display device, a logic device, a memory device, and/or a memory device having computer-readable storage media.

**[0034]** The computer-readable storage media, when present, also may be referred to herein as non-transitory computer readable storage media **62**. This non-transitory computer readable storage media **62** may include, define, house, and/or store computer-executable instructions, programs, and/or code; and these computer-executable instructions may direct additive manufacturing systems **10** and/or controller **60** thereof to perform any suitable portion, or subset, of methods **100**. Examples of such non-transitory computer-readable storage media include CD-ROMs, disks, hard drives, flash memory, etc. As used herein, storage, or memory, devices and/or media having computer-executable instructions, as well as computer-implemented methods and other methods according to the present disclosure, are considered to be within the scope of subject matter deemed patentable in accordance with Section 101 of Title 35 of the United States Code.

[0035] During operation of additive manufacturing systems 10, energy source 40 may provide amount of energy 42 to addition location 94. Concurrently and/or previously, depending upon the specific additive manufacturing process that is utilized, feedstock supply system 30 may provide feedstock material 32 to addition location 94. Amount of energy 42 may be absorbed by feedstock material 32 at addition location 94, which may soften and/or melt feedstock material 32, forming a melt pool 38 at addition location 94. This process may be repeated, with amount of energy 42 being supplied at addition locations 94 where manufactured component 90 is to be formed, or where feedstock material 32 is to be added to a previously formed portion 92 of manufactured component 90, to form, define, and/or complete manufactured component 90.

[0036] Turning to FIGS. 2-3, a size of melt pool 38 that may be generated by a given amount of energy 42 may vary with position within previously formed portion 92 of manufactured component 90. As an example, thermal conductivity of amount of energy 42 away from melt pool 38 may be greater within an interior region of previously formed portion 92, as illustrated in FIG. 2, when compared with an edge region of previously formed portion 92, as illustrated in FIG. 3. This may cause melt pool 38 to be relatively smaller within the interior region when compared to the edge region. This variation in the size of melt pool 38 may cause one or more properties of manufactured component 90 to vary between the interior region and the edge region. This variation may be undesirable and/or may cause defects within manufactured component 90. With this in mind, and as discussed in more detail herein, methods 100 may control, regulate, and/or vary amount of energy 42, such as to decrease the variation in the size of melt pool 38 and/or to decrease variation in the one or more properties of manufactured component 90.

[0037] FIG. 4 is a flowchart depicting examples of methods 100 of additively manufacturing a manufactured component, according to the present disclosure. Methods 100 include determining an energy application parameter at 110 and supplying a feedstock material at 120. Methods 100 also include delivering an amount of energy at 130 and consolidating a melt pool at 140. Methods 100 further may include repeating at 150.

[0038] Determining the energy application parameter at 110 may include determining, establishing, and/or calculating the energy application parameter at an addition location on a previously formed portion of the manufactured component. Stated differently, the energy application parameter, a value of the energy application parameter, and/or a magnitude of the energy application parameter may be location-specific, may be specific to a given addition location, may vary with location, and/or may vary for different addition locations on the previously formed portion of the manufactured component. Examples of the addition location are disclosed herein with reference to addition location 94. Examples of the previously formed portion of the manufactured component are disclosed herein with reference to previously formed portion 92 of manufactured component 90.

[0039] The determining at 110 may be performed in any suitable manner. As an example, the determining at 110 may include determining the energy application parameter based, at least in part, on a rate of thermal energy dissipation at the addition location and/or within the previously formed por-

tion of the manufactured component. Stated differently, with reference to FIGS. 2-3, and as discussed in more detail herein, the rate of thermal energy dissipation, at the addition location, may vary with the geometry of the previously formed portion of the manufactured component and/or with the position of the addition location within the previously formed portion of the manufactured component. The energy application parameter may be utilized to account and/or to adjust for this variation, thereby permitting and/or facilitating more well-regulated control of melt pool size and/or of the material properties of the manufactured component.

[0040] As another example, the determining at 110 may include determining the energy application parameter based, at least in part, on an angle of incidence between the application location and the amount of energy. Stated differently, and as discussed in more detail herein, changes in the angle of incidence may cause the amount of energy to be absorbed and/or dissipated differently at different addition locations on the previously formed portion of the manufactured component. The energy application parameter may be utilized to account and/or to adjust for this variation, once again permitting and/or facilitating more well-regulated control of melt pool size and/or of the material properties of the manufactured component.

[0041] As yet another example, the determining at 110 may include determining the energy application parameter based, at least in part, on an efficiency of absorption of the amount of energy by the previously formed portion of the manufactured component. Stated differently, and as discussed in more detail herein, changes in the geometry and/or materials of the previously formed portion of the manufactured component may cause the amount of energy to be absorbed and/or dissipated differently, or with different efficiencies, at different addition locations on the previously formed portion of the manufactured component. The energy application parameter may be utilized to account and/or to adjust for this variation, once again permitting and/or facilitating more well-regulated control of melt pool size and/or of the material properties of the manufactured component.

[0042] As another example, the determining at 110 may include determining the energy application parameter based, at least in part, on a direction of absorption of the amount of energy by the previously formed portion of the manufactured component. Stated differently, and as discussed in more detail herein, the direction of absorption of the amount of energy, within the previously formed portion of the manufactured component, may cause the amount of energy to be absorbed and/or dissipated differently at different addition locations on the previously formed portion of the manufactured component. The energy application parameter may be utilized to account and/or to adjust for this variation, once again permitting and/or facilitating more well-regulated control of melt pool size and/or of the material properties of the manufactured component.

[0043] As yet another example, the determining at 110 may include determining the energy application parameter based, at least in part, on a material property of the feedstock material. Examples of the material property of the feedstock material include a latent heat of fusion of the feedstock material, a thermal conductivity of the feedstock material, and/or a melting point of the feedstock material. In some such examples, such as when methods 100 are performed within additive manufacturing systems in which bulk feedstock material is in thermal contact with the previously



formed portion of the manufactured component, these material properties may have a significant impact on the size of a melt pool that is generated by a given amount of energy. The energy application parameter may be utilized to account and/or to adjust for this thermal contact, once again permitting and/or facilitating more well-regulated control of melt pool size and/or of the material properties of the manufactured component.

**[0044]** As another example, the determining at **110** may include determining the energy application parameter based, at least in part, on a material property of the previously formed portion of the manufactured component. Examples of the material property of the previously formed portion of the manufactured component include a latent heat of fusion of the previously formed portion of the manufactured component, a thermal conductivity of the previously formed portion of the manufactured component, and/or a melting point of the previously formed portion of the manufactured component. Energy dissipation within the previously formed portion of the manufactured component may be significantly impacted by these material properties and thereby may have a significant impact on the size of a melt pool that is generated by a given amount of energy. The energy application parameter may be utilized to account and/or to adjust for this energy dissipation, once again permitting and/or facilitating more well-regulated control of melt pool size and/or of the material properties of the manufactured component.

**[0045]** As yet another example, the determining at **110** may include determining the energy application parameter based, at least in part, on a shape of the previously formed portion of the manufactured component. The shape of the previously formed portion of the manufactured component may impact a contact area between the melt pool and a remainder of the previously formed portion of the manufactured component and/or may impact an ability of the previously formed portion of the manufactured component to dissipate energy from the melt pool.

**[0046]** As another example, the determining at **110** may include determining the energy application parameter based, at least in part, on a temperature of the previously formed portion of the manufactured component. The temperature, or the current temperature, of the previously formed portion of the manufactured component, may impact a driving force for energy dissipation from the melt pool and/or into the previously formed portion of the manufactured component. As a more specific example, a temperature differential between a melt pool temperature of the melt pool and the temperature of the previously formed portion of the manufactured component may impact a rate at which thermal energy is dissipated via conduction within the previously formed portion of the manufactured component. The energy application parameter may be utilized to account and/or to adjust for this variation in energy dissipation, once again permitting and/or facilitating more well-regulated control of melt pool size and/or of the material properties of the manufactured component.

**[0047]** As yet another example, the determining at **110** may include determining the energy application parameter based, at least in part, on an environmental factor of and/or within an environment that surrounds the melt pool and/or the previously formed portion of the manufactured component. Examples of the environmental property include a material property of an environmental gas within the envi-

ronment surrounding the previously formed portion of the manufactured component and/or a material property of a support platform that supports the previously formed portion of the manufactured component. The environmental factor may impact energy dissipation from the melt pool, such as energy dissipation into the environmental gas and/or into the support platform. The energy application parameter may be utilized to account and/or to adjust for this variation in energy dissipation, once again permitting and/or facilitating more well-regulated control of melt pool size and/or of the material properties of the manufactured component.

**[0048]** Supplying the feedstock material at **120** may include supplying the feedstock material to the addition location. This may include supplying the feedstock material with, via, and/or utilizing a feedstock supply system. Examples of the feedstock material are disclosed herein with reference to feedstock material **32**. Examples of the feedstock supply system are disclosed herein with reference to feedstock supply system **30**.

**[0049]** The supplying at **120** may be accomplished in any suitable manner. As an example, the supplying at **120** may include supplying a powder feedstock material. Examples of the powder feedstock material include a metallic powder feedstock material, a polymeric powder feedstock material, and/or a composite powder feedstock material. As another example, the supplying at **120** may include supplying a feedstock material filament. Examples of the feedstock material filament include a wire, an electrically conductive filament, a metallic filament, a polymeric filament, and/or a composite filament.

**[0050]** In some examples, the supplying at **120** may include distributing a layer of the feedstock material, or of the powder feedstock material, on a surface, or on an exposed upper surface, of the previously formed portion of the manufactured component. In some such examples, the supplying at **120** may be performed prior to the delivering at **130**. Stated differently, and in some such examples, the layer of the feedstock material may be distributed on the surface of the previously formed portion of the manufactured component prior to delivery of the amount of energy to the addition location.

**[0051]** In some examples, the supplying at **120** may be performed concurrently and/or cooperatively with the delivering at **130**. In some such examples, the supplying at **120** may permit and/or facilitate the delivering at **130**. Stated differently, and in some such examples, the delivering at **130** may include delivering the amount of energy in, within, and/or via the feedstock material. Additionally or alternatively, and in some such examples, the delivering at **130** may include delivering the amount of energy via an energy delivery mechanism that is separate and/or distinct from the feedstock material.

**[0052]** More specific examples of additive manufacturing processes that may be utilized with methods **100** are discussed below. The described additive manufacturing processes are included herein as illustrative, non-exclusive examples of additive manufacturing processes, according to the present disclosure, and it is within the scope of the present disclosure that methods **100** may be utilized to control other additive manufacturing processes in addition to and/or instead of those described herein.

**[0053]** An example of additive manufacturing processes that may utilize methods **100** includes powder bed fusion processes, such as laser powder bed fusion and/or electron

beam powder bed fusion. In such powder bed fusion processes, the feedstock material includes the powdered feedstock material, and the supplying at **120** includes distributing the layer of the powdered feedstock material on the surface of the previously formed portion of the manufactured component. This is performed prior to the delivering at **130**. Also in such powder bed fusion processes, the addition location is defined on the surface of the previously formed portion of the manufactured component, and the delivering at **130** includes delivering the amount of energy to the addition location separately from distribution of the powdered feedstock material. As examples, the delivering at **130** may include delivering the amount of energy in the form of a laser beam that is directed incident upon the addition location and/or in the form of an electron beam that is directed incident upon the addition location.

**[0054]** Another example of additive manufacturing processes that may utilize methods **100** include powder feed processes, such as powder feed directed energy deposition and/or other powder-based directed energy deposition processes. In such powder feed processes, the feedstock material includes the powdered feedstock material, and the supplying at **120** includes flowing the powdered feedstock material to the addition location as a feedstock material stream. This is performed concurrently with the delivering at **130**.

**[0055]** Yet another example of additive manufacturing processes that may utilize methods **100** include filament, or wire, feed processes, such as wire feed directed energy deposition, fused deposition modeling, wire arc additive manufacturing, and/or other filament-based directed energy deposition processes. In such filament feed processes, the feedstock material includes the feedstock material filament, the supplying at **120** includes conveying the feedstock material filament to the addition location, and/or the delivering at **130** may be performed concurrently with the supplying at **120**. In some such filament feed processes, the delivering at **130** may include delivering the amount of energy via the feedstock material filament, such as by heating the feedstock material filament prior to delivery to the addition location and/or generating a voltage differential between the feedstock material filament and the addition location. Additionally or alternatively, and in some such filament feed processes, the delivering at **130** may include delivering the amount of energy via the energy delivery mechanism that is distinct from the feedstock material, such as by directing a laser, an electron beam, and/or an electric arc incident upon the addition location.

**[0056]** Delivering the amount of energy at **130** may include delivering the amount of energy from an energy source. The amount of energy may be sufficient to form a melt pool of the feedstock material at the addition location and may be based, at least in part, on the energy application parameter. Stated differently, a magnitude of the amount of energy may be selected and/or delivered based, at least in part, on the energy application parameter, on a value of the energy application parameter, and/or on a magnitude of the energy application parameter. Examples of the energy source are disclosed herein with reference to energy source **40**. Examples of the melt pool are disclosed herein with reference to melt pool **38**. Examples of the amount of energy include an amount of electric energy, an amount of photon energy, an amount of electron beam energy, and/or an

amount of heat. The amount of energy generally may be quantified in units of energy, such as Joules and/or electron volts.

**[0057]** In some examples, the delivering at **130** may include delivering such that the amount of energy is proportional, directly proportional, and/or linearly proportional to the energy application parameter, or to the magnitude of the energy application parameter. In some examples, the delivering at **130** may include delivering such that the amount of energy increases with an increase in the energy application parameter, or with an increase in the magnitude of the energy application parameter. In some examples, the delivering at **130** may include delivering such that the amount of energy decreases with a decrease in the energy application parameter, or with a decrease in the magnitude of the energy application parameter.

**[0058]** In some examples, the delivering at **130** may include selectively varying the amount of energy based, at least in part, on the energy application parameter and/or on variation in the energy application parameter. The selectively varying may be accomplished in any suitable manner. As examples, the selectively varying may include selectively varying a power consumption of the energy source, an intensity of energy incident upon the addition location, an exposure time of energy incident upon the addition location, and/or an application area over which the energy is incident upon the addition location (e.g., a size and/or area of the addition location).

**[0059]** Consolidating the melt pool at **140** may include consolidating the melt pool with the previously formed portion of the manufactured component. This may include consolidating to form and/or to define an additional portion of the manufactured component. Stated differently, and upon consolidation of the melt pool, feedstock material, which is contained within the melt pool, may fuse to, may add to, and/or may become a portion of the previously formed portion of the manufactured component, thereby increasing a size and/or volume of the previously formed portion of the manufactured component.

**[0060]** The consolidating at **140** may be accomplished in any suitable manner. As an example, the consolidating at **140** may include solidifying the melt pool. As another example, the consolidating at **140** may include cooling the melt pool to below a melting temperature of the feedstock material. As yet another example, the consolidating at **140** may include fusing the feedstock material, from the melt pool, to the previously formed portion of the manufactured component.

**[0061]** Repeating at **150** may include repeating any suitable step and/or steps of methods **100** in any suitable manner and/or for any suitable purpose. As an example, the repeating at **150** may include repeating at least the determining at **110**, the delivering at **120**, and the consolidating **140** a plurality of times at a plurality of, or at a plurality of different, addition locations to fully define the manufactured component. This may include selecting the amount of energy at each addition location of the plurality of addition locations based, at least in part, on a corresponding energy application parameter at each location. Stated differently, the amount of energy may vary from one addition location to another addition location, with this variation being based, at least in part, on a variation in corresponding energy application parameter from the one addition location to the other addition location.

**[0062]** The selecting the amount of energy may be performed in any suitable manner. As an example, the selecting the amount of energy may include increasing the amount of energy at a given addition location of the plurality of addition locations, relative to another addition location of the plurality of addition locations, responsive to an increase in the corresponding energy application parameter at the given addition location relative to the other addition location. As another example, the selecting the amount of energy may include increasing the amount of energy at the given addition location, relative to the other addition location, responsive to a decrease in the corresponding energy application parameter at the given addition location relative to the other addition location. As yet another example, the selecting the amount of energy may include decreasing the amount of energy at the given addition location, relative to the other addition location, responsive to a decrease in the corresponding energy application parameter at the given addition location relative to the other addition location. As another example, the selecting the amount of energy may include decreasing the amount of energy at the given addition location, relative to the other addition location, responsive to an increase in the corresponding energy application parameter at the given addition location relative to the other addition location.

**[0063]** In some examples, and for a given addition location of the plurality of addition locations, the repeating at **150** also may include adjusting the amount of energy based, at least in part, on an already delivered amount of energy that already has been delivered to the previously formed portion of the manufactured component. As a more specific example, and during the repeating at **150**, the corresponding amount of energy may be provided to the plurality of addition locations. This may cause energy, or heat, to build up within the previously formed portion of the manufactured component, with this energy, or heat, build up increasing with time during formation of the manufactured component. With this in mind, adjusting may, for example, include decreasing the amount of energy, which would be provided to a given addition location based solely upon the energy application parameter, to account, or to adjust, for the energy, or heat, build up. This adjustment may further fine-tune the amount of energy provided to the given addition location, thereby further improving control of melt pool size and/or of material properties of the manufactured component.

**[0064]** As another example, the addition location may include and/or be a first addition location, the energy application parameter may include and/or be a first energy application parameter, the amount of energy may include and/or be a first amount of energy, the melt pool may include and/or be a first melt pool, and the additional portion of the manufactured component may include and/or be a second additional portion of the manufactured component. In this example, the repeating at **150** may include repeating the determining at **110** to determine a second energy application parameter at a second addition location on the previously formed portion of the manufactured component. Also in this example, the repeating at **150** may include supplying the feedstock material to the second addition location. In some such examples, such as when the supplying at **120** is performed concurrently with the delivering at **130**, this may include repeating the supplying at **120**. In other such examples, such as when the supplying at **120** is performed

prior to the delivering at **130**, the supplying the feedstock material to the second addition location may have been performed during supply of the feedstock material to the first addition location.

**[0065]** Also in this example, the repeating at **150** may include repeating the delivering at **130** to deliver, from the energy source and to the second addition location, a second amount of energy sufficient to form a second melt pool of the feedstock material at the second addition location. In this example, the second amount of energy is based, at least in part, on the second energy application parameter. Also in this example, the repeating at **150** may include repeating the consolidating at **140** to consolidate the second melt pool with the previously formed portion of the manufactured component. This may include consolidating to form and/or define a second additional portion of the manufactured component.

**[0066]** In such examples, the second energy application parameter may differ from the first energy application parameter. Additionally or alternatively, and in such examples, the second amount of energy may differ from the first amount of energy. This difference between the second amount of energy and the first amount of energy may be based, at least in part, on the difference between the second energy application parameter and the first energy application parameter.

**[0067]** In such examples, a first melt pool size of the first melt pool may be equal, or at least substantially equal, to a second melt pool size of the second melt pool. Additionally or alternatively, a first melt pool shape of the first melt pool may be equal, or at least substantially equal, to a second melt pool shape of the second melt pool. Stated differently, the difference between the second amount of energy and the first amount of energy may be specifically selected, determined, and/or calculated, via the difference between the second energy application parameter and the first energy application parameter, to provide a constant, or at least substantially constant, melt pool size and/or melt pool shape during the repeating at **150**. Examples of the first melt pool size and/or of the second melt pool size include a volume, a maximum dimension, a diameter, and/or a characteristic dimension of the first melt pool and/or of the second melt pool.

**[0068]** In some examples, the determining the first energy application parameter and the determining the second energy application parameter may include determining such that the second melt pool is within a threshold melt pool size range of the first melt pool. Examples of the threshold melt pool size range include at least 80%, at least 85%, at least 90%, at least 95%, at least 97.5%, at least 99%, at most 120%, at most 115%, at most 110%, at most 105%, at most 102.5%, and/or at most 101% of the first melt pool size.

**[0069]** In some examples, the determining the first energy application parameter and the determining the second energy application parameter may include determining such that a second penetration depth of the second melt pool into the previously formed portion of the manufactured component is within a threshold penetration depth range of a first penetration depth of the first melt pool into the previously formed portion of the manufactured component. Examples of the threshold penetration depth range include at least 80%, at least 85%, at least 90%, at least 95%, at least 97.5%, at least 99%, at most 120%, at most 115%, at most 110%, at most 105%, at most 102.5%, and/or at most 101% of the first penetration depth.

[0070] The following discussions represent more specific versions of methods 100. These more specific versions of methods 100 determine more specific energy application parameters, during the determining at 110, and the amount of energy delivered, during the delivering at 130, is based, at least in part, on these more specific energy application parameters.

[0071] In a first example, the energy application parameter includes, is, or instead is an overlap volume between a virtual geometric shape and the previously formed portion of the manufactured component. The overlap volume also may be referred to herein as a volume of intersection and/or as an overlap volume between the virtual geometric shape and the previously formed portion of the manufactured component.

[0072] An example of the virtual geometric shape is illustrated in FIG. 5 and indicated at 80. In FIG. 5, amount of energy 42 is being delivered to addition location 94, and the centroid of virtual geometric shape 80 is positioned at addition location 94. FIG. 5 also illustrates an overlap volume 82 between virtual geometric shape 80 and previously formed portion 92 of manufactured component 90.

[0073] Overlap volume 82 may be indicative of, or proportional to, a volume and/or surface area for energy transfer between addition location 94 and a remainder of previously formed portion 92. As an example, and as illustrated in FIG. 6, conditions in which addition location 94 is centered on an exposed surface of previously formed portion 92 may indicate a maximum value for overlap volume 82 and also may indicate a maximum potential for energy transfer between previously formed portion 92 and addition location 94. However, overlap volume 82 may decrease substantially when addition location 94 is centered on an edge of previously formed portion 92, as illustrated in FIG. 7, and/or on a corner of previously formed portion 92, as illustrated in FIG. 8.

[0074] The virtual geometric shape 80 may be positioned at addition location 94. As an example, virtual geometric shape 80 may be centered at the addition location 94 and/or may be centered at a center of the addition location 94. As another example, a centroid of virtual geometric shape 80 may be positioned the addition location 94.

In some examples, the delivering at 130 may include delivering amount of energy 42 along an axis of incidence, an example of which is illustrated in FIGS. 5-8 and indicated at 84. In some such examples, virtual geometric shape 80 may be symmetric, or rotationally symmetric, about axis of incidence 84.

[0075] As discussed in more detail herein, examples of virtual geometric shape 80 include a sphere, an ellipsoid, a cylinder, and/or a cone. When the virtual geometric shape is the sphere, overlap volume 82 may be an at least partially spherical overlap volume. When the virtual geometric shape is the ellipsoid, overlap volume 82 may be an at least partially ellipsoidal overlap volume. When the virtual geometric shape is the cylinder, overlap volume 82 may be an at least partially cylindrical overlap volume. When the virtual geometric shape is a cone, overlap volume 82 may be an at least partially conic overlap volume. In some examples, such as when virtual geometric shape 80 is the ellipsoid, the cylinder, and/or the cone, the virtual geometric shape may define an elongate axis. In such examples, the elongate axis may extend along axis of incidence 84.

[0076] While, as discussed, a location of the virtual geometric shape may vary with the addition location, the virtual

geometric shape may be invariant and/or fixed during methods 100. As examples, the virtual geometric shape may have a fixed and/or a predetermined size, volume, maximum dimension, characteristic dimension, and/or shape during methods 100.

[0077] In some examples, virtual geometric shape 80 may have and/or define a virtual geometric shape volume. In such examples, overlap volume 82 may be less than the virtual geometric shape volume. As an example, and as illustrated in FIGS. 5-8, overlap volume 82 may be at most half of the virtual geometric shape volume.

[0078] In order to provide a desired level of sensitivity to variations in the overlap volume, the virtual geometric shape may be sized based, at least in part, on a size of manufactured component 90. As an example, the size, volume, maximum dimension, and/or characteristic dimension of the virtual geometric shape may be a threshold size fraction of a corresponding size, volume, maximum dimension, and/or characteristic dimension of the manufactured component. Examples of the threshold size fraction include at least 0.01%, at least 0.05%, at least 0.1%, at least 0.5%, at least 1%, at least 2.5%, at least 5%, at least 10%, at most 25%, at most 20%, at most 15%, at most 10%, at most 5%, at most 2.5%, and/or at most 1%.

[0079] In some examples and as discussed, methods 100, or the repeating at 150, may include varying a position of the addition location on the previously formed portion of the manufactured component, such as to form and/or define a plurality of addition locations. This is illustrated in FIGS. 6-8. In some such examples, during the varying, and as also discussed, the repeating at 150 may include repeating at least the determining at 110, the delivering at 130, and the consolidating at 140 a plurality of times at the plurality of addition locations, such as to fully define the manufactured component. In such examples, the repeating the determining at 110 may include determining a corresponding overlap volume at each addition location, and the delivering at 130 may include delivering a corresponding amount of energy at each addition location. The corresponding amount of energy may be based upon and/or may be proportional to the corresponding overlap volume.

[0080] In some such examples, and responsive to the corresponding overlap volume at a given addition location decreasing from the corresponding overlap volume at a prior addition location, the repeating the delivering at 140 may include decreasing the corresponding amount of energy delivered at the given addition location relative to the corresponding amount of energy delivered at the prior addition location. This is illustrated, for example, by the transition from addition location 94 that is illustrated in FIG. 6 (e.g., the prior addition location) to addition location 94 that is illustrated in FIG. 7 (e.g., the given addition location). As illustrated, overlap volume 82 decreases substantially from FIG. 6 to FIG. 7, and methods 100 account for this decrease in overlap volume by decreasing amount of energy 42 delivered at addition location 94 of FIG. 7 relative to amount of energy 42 delivered at addition location 94 of FIG. 6.

[0081] In some such examples, and responsive to the corresponding overlap volume at the given addition location increasing from the corresponding overlap volume at the prior addition location, the repeating the delivering at 140 may include increasing the corresponding amount of energy delivered at the given addition location relative to the

corresponding amount of energy delivered at the prior addition location. This is illustrated, for example, by the transition from addition location **94** that is illustrated in FIG. 7 (e.g., the prior addition location) to addition location **94** that is illustrated in FIG. 6 (e.g., the given addition location). As illustrated, overlap volume **82** increases substantially from FIG. 7 to FIG. 6, and methods **100** account for this increase in overlap volume **82** by increasing amount of energy **42** delivered at addition location **94** of FIG. 6 relative to amount of energy **42** delivered at addition location **94** of FIG. 7.

**[0082]** In some examples, overlap volume **82** may include and/or be a first overlap volume, and overlap volume **82** also may include a second, or additional, overlap volume. The first overlap volume may include overlap between virtual geometric shape **80** and previously formed portion **92** of the manufactured component, and the second, or additional, overlap volume may include overlap between virtual geometric shape **80** and at least one environmental component in an environment that surrounds previously formed portion **92** of manufactured component **90**. Examples of the at least one environmental component include a support platform for the previously formed portion of the manufactured component, the feedstock material, and/or environmental gas. Additional examples of the at least one environmental component include a region of the manufactured component and/or of another manufactured component that is discontinuous with, not connected to, or not yet connected to the previously formed portion of the manufactured component.

**[0083]** As illustrated in FIG. 5, virtual geometric shape **80** may overlap both with previously formed portion **92** of manufactured component **90** and also with environmental components **89**, such as support platform **20**, feedstock material **32**, an environmental gas **58**, and/or discontinuous regions **96** of manufactured component **90** and/or of another manufactured component. Each of these environmental components may define a corresponding second, or subsequent, overlap volume **88** with virtual geometric shape **80**.

**[0084]** Each of these environmental components also may dissipate energy from the addition location; however, an efficiency and/or rate at which these environmental components dissipate energy from the addition location may vary significantly when compared to an efficiency and/or rate at which the previously formed portion of the manufactured component dissipates energy from the addition location.

**[0085]** When the overlap volume includes both the first overlap volume and the second, or subsequent, overlap volume(s), and in some examples, the amount of energy may be based, at least in part, on only the first overlap volume. Stated differently, the amount of energy may be determined based upon overlap between the virtual geometric shape and the environmental components. Alternatively, and in other examples, the amount of energy may be based, at least in part, on both the first overlap volume and the second, or additional, overlap volume(s). In such a configuration, the amount of energy may be weighted differently for the first overlap volume when compared to the second, or additional overlap volume(s).

**[0086]** In a second example, the energy application parameter includes, is, or instead is an intersection area relationship. The intersection area relationship may describe an area of intersection **70** between the previously formed portion of the manufactured component and a surface of the virtual geometric shape as a function of a size parameter of the

virtual geometric shape while virtual geometric shape is positioned at the addition location.

**[0087]** An example of the intersection area relationship is illustrated in FIG. 9. More specifically, FIG. 9 plots two different intersection area relationships. One, which is indicated at A, is taken from previously formed portion **92** of manufactured component **90** that is illustrated in FIGS. 10-12 and the other, which is indicated at B, is taken from previously formed portion **92** of manufactured component **90** that is illustrated in FIGS. 13-15. Previously formed portion **92** of FIGS. 10-12 differs from previously formed portion **92** of FIGS. 13-15 only in that previously formed portion **92** of FIGS. 13-15 includes a gap **72**, a void **72**, or an inclusion **72**. Gap **72** may function as a thermal conduction bottleneck, such as by causing a decrease in a cross-sectional area for thermal conduction within previously formed portion **92** and/or away from addition location **94**. For the intersection area relationships of FIG. 9, addition location **94** is positioned at a projecting corner of previously formed portion **92**, and FIG. 9 plots the surface area of intersection between a spherical virtual geometric shape as a function of the radius of the spherical geometric shape.

**[0088]** As may be seen from FIG. 9, when the radius of the virtual geometric shape is small, the intersection area relationship is identical for the two examples. This is illustrated graphically by FIGS. 10 and 13. However, as the radius of the virtual geometric shape is increased, the intersection between the virtual geometric shape and previously formed portion **92** eventually contacts gap **72**. The presence of gap **72** causes area of intersection **70** for previously formed portion **92** of FIGS. 13-15 to be less than area of intersection **70** for previously formed portion **92** of FIGS. 10-12.

**[0089]** This decrease in area of intersection **70** may alter, or decrease, the ability of previously formed portion **92** of FIGS. 13-15 to convey energy away from addition location **94** when compared to previously formed portion **92** of FIGS. 10-12. The intersection area relationship illustrated in FIG. 9 quantifies this variation and/or may be utilized by methods **100** to account for the longer-distance ability of a given manufactured component to convey energy away from the addition location, thereby permitting and/or facilitating more accurate control of the size of the melt pool and/or of the material properties of the manufactured component.

**[0090]** While illustrated as a plot in FIG. 9, it is within the scope of the present disclosure that the intersection area relationship may have any suitable form. Examples of the intersection area relationship include a plot of the area of intersection as a function of the size parameter, tabulated values of the area of intersection and corresponding values of the size parameter, and/or a functional relationship between the area of intersection and the size parameter.

**[0091]** The area of intersection may be defined in any suitable manner. As an example, and for a given size parameter of the virtual geometric shape, a corresponding area of intersection may quantify a surface area of an outer surface of the virtual geometric shape that extends within, intersects, and/or contacts the previously formed portion of the manufactured component.

**[0092]** The virtual geometric shape may include and/or be any suitable virtual geometric shape, and examples of the virtual geometric shape are disclosed herein. In this second example, the virtual geometric shape may have a constant, or at least substantially constant, shape and/or proportion. Stated differently, and while the size, or the size parameter,

of the virtual geometric shape may be varied, such as to generate the intersection area relationship, the proportions of the virtual geometric shape may be invariant and/or fixed. Stated still differently, the virtual geometric shape defined by one size parameter may be similar, or geometrically similar, to the virtual geometric shape defined by another, or a different, size parameter. However, for a given size parameter, the virtual geometric shape may have and/or define a given virtual geometric shape volume, which corresponds to the given size parameter.

**[0093]** The size parameter may include and/or be any suitable size parameter for the virtual geometric shape. As examples, the size parameter may be indicative of a volume of the virtual geometric shape and/or of a surface area of the virtual geometric shape. As more specific examples, the size parameter may include and/or be a radius of the virtual geometric shape, a diameter of the virtual geometric shape, an effective radius of the virtual geometric shape, an effective diameter of the virtual geometric shape, a circumference of the virtual geometric shape, a volume of the virtual geometric shape, and/or a surface area of the virtual geometric shape.

**[0094]** In some examples of methods **100**, the determining at **110** may include generating the intersection area relationship. This may include quantifying the area of intersection between the previously formed portion of the manufactured component and the surface of the virtual geometric shape for a plurality of different size parameters of the virtual geometric shape.

**[0095]** The generating the intersection area relationship may be accomplished in any suitable manner. As an example, the generating the intersection area relationship may include virtually positioning the virtual geometric shape at the addition location, and determining, for a plurality of different size parameters of the virtual geometric shape, a corresponding plurality of areas of intersection between the previously formed portion of the manufactured component and the surface of the virtual geometric shape. In this example, the generating the intersection area relationship further may include producing the intersection area relationship based, at least in part, on the plurality of different size parameters and the corresponding plurality of areas of intersection.

**[0096]** Producing the intersection area relationship may be performed in any suitable manner. As an example, the producing the intersection area relationship may include producing a plot of the intersection area as a function of the size parameter, as illustrated in FIG. **9**. Additionally or alternatively, the producing the intersection area relationship may include producing tabulated values of the area of intersection and the corresponding values of the size parameter. Additionally or alternatively, the producing the intersection area relationship may include producing a functional relationship between the area of intersection and the size parameter, such as via curve fitting the plurality of different size parameters and the corresponding plurality of areas of intersection. Additionally or alternatively, the producing the intersection area relationship may include determining a slope, an average slope, a minimum slope, and/or a maximum slope of the area of intersection as the function of the size parameter. Additionally or alternatively, the producing the intersection area relationship may include determining the slope of the area of intersection as the function of the size parameter for a specific value, or for specific values, of the

size parameter. Additionally or alternatively, the producing the intersection area relationship may include determining the slope of the area of intersection as a function of the size parameter.

**[0097]** In some examples, the generating the intersection area relationship may include omitting, from the area of intersection, intersection of the surface of the virtual geometric shape with a region of the previously formed portion of the manufactured component, or with a previously formed portion of another manufactured component, that is not contiguous, or is discontinuous, with a region of the previously formed portion of the manufactured component that includes the addition location. In some examples, this omitted region eventually may be connected to the region of the previously formed portion of the manufactured component that includes the addition location, such as within the completed manufactured component. However, this omitted region may not be contiguous with, or connected to, the region of the previously formed portion of the manufactured component that includes the addition location. Such an omitted region may not provide a pathway for significant heat and/or energy dissipation from the addition location. As such, the omitting may permit more accurate generation of the intersection area relationship and/or of an intersection area relationship that accurately quantifies pathways for heat and/or energy dissipation within the previously formed portion of the manufactured component.

**[0098]** An example of the omitting is illustrated in FIG. **16**. As illustrated therein, previously formed portion **92** of manufactured component **90** is illustrated as including addition location **94**. In addition, a region **96** that is not contiguous with previously formed portion **92** also is illustrated. During generation of the intersection area relationship, virtual geometric shapes **80** with varying size parameters **81** may be positioned at addition location **94** and the area of intersection between each virtual geometric shape **80** and previously formed portion **92** may be determined, thereby permitting and/or facilitating determination of the intersection area relationship. However, and because region **96** does not provide significant heat and/or energy dissipation from addition location **94**, an area of intersection between a given virtual geometric shape **80**, with a given size parameter **81**, and region **96** may not be included in the intersection area relationship.

**[0099]** It is within the scope of the present disclosure that the amount of energy, as delivered during the delivering at **130**, may be based upon the intersection area relationship in any suitable manner. As an example, the delivering at **130** may include decreasing the amount of energy when a rate of change of the intersection area relationship with respect to the size parameter is less than a threshold rate of change and/or decreasing the amount of energy proportionate to the rate of change of the intersection area relationship. The threshold rate of change may have any suitable value, including a negative value, a positive value, or zero. As another example, the delivering at **130** may include increasing the amount of energy when the rate of change of the intersection area relationship with respect to the size parameter is greater than the threshold rate of change and/or increasing the amount of energy proportionate to the rate of change of the intersection area relationship. As yet another example, the delivering at **130** may include changing and/or specifying the amount of energy proportionate to the rate of change of the intersection area relationship. As another

example, and when the rate of change of the intersection area relationship is less than the threshold rate of change, methods **100** may include determining that the addition location is proximate a void within the previously formed portion of the manufactured component. This may indicate that dissipation of heat and/or energy from the addition location may be less and/or slower than otherwise would be expected.

**[0100]** In a third example, and as discussed, during the delivering at **130**, the amount of energy may be delivered along an axis of incidence. An example of the axis of incidence is illustrated in FIGS. **17-22** and indicated at **84**. In this example, the energy dissipation parameter includes, is, or instead is a directionality parameter that is based, at least in part, on the axis of incidence.

**[0101]** Also in this example, the delivering at **130** may include delivering such that the amount of energy relatively increases when the directionality parameter indicates that the amount of energy is directed toward an edge of the previously formed portion of the manufactured component and an underlying surface of the previously formed portion of the manufactured component, which partially defines the edge, is relatively proximate the axis of incidence. This is illustrated in FIGS. **17, 19** and **21**, where amount of energy **42** is directed toward an edge **98** of previously formed portion **92** of manufactured component **90** and an underlying surface **93** of previously formed portion **92** extends relatively proximate axis of incidence **84**. Additionally or alternatively, the delivering at **130** may include delivering such that the amount of energy decreases when the directionality parameter indicates that the amount of energy is directed toward the edge of the previously formed portion of the manufactured component and the underlying surface of the previously formed portion of the manufactured component is relatively distal the axis of incidence. This is illustrated in FIGS. **18, 20** and **22**, where amount of energy **42** is directed toward edge **98** of previously formed portion **92** of manufactured component **90** and underlying surface **93** extends distal axis of incidence **84** and/or relatively distal axis of incidence **84** compared to the examples illustrated in FIGS. **17, 19**, and **21**. Stated differently, the directionality parameter may indicate the orientation between the axis of incidence and the previously formed portion of the manufactured component, may indicate a direction of approach between the axis of incidence and the previously formed portion of the manufactured component, and/or may vary the amount of energy based upon this orientation and/or based upon this direction of approach.

**[0102]** As an example, and with reference to FIGS. **17-18**, previously formed portion **92** may more readily absorb amount of energy **42**, or may absorb a greater fraction of amount of energy **42**, when axis of incidence **84** is directed toward edge **98**, as illustrated in FIG. **17**, when compared to when axis of incidence **84** is directed away from edge **98**, as illustrated in FIG. **18**. Thus, for a given addition location the amount of energy may be relatively higher when the directionality parameter indicates that the amount of energy is directed toward the edge of the previously formed portion of the manufactured component, and the amount of energy may be relatively lower when the directionality parameter indicates that the amount of energy is directed away from the edge of the previously formed portion of the manufactured component.

**[0103]** The directionality parameter may be determined and/or established in any suitable manner. The following are several illustrative, non-exclusive examples of directionality parameters and/or of mechanisms via which the directionality parameter may be determined, quantified, and/or utilized.

**[0104]** In some examples, the directionality parameter may include and/or be a weighting function, which may be applied to an internal volume of the virtual geometric shapes that are disclosed herein. The weighting function, when utilized, may provide additional weight to overlap volumes that are relatively proximate the axis of incidence within the virtual geometric shape when compared to overlap volumes that are relatively distal the axis of incidence within the virtual geometric shape. Stated differently, the weighting function may be relatively higher within a region of the virtual geometric shape that is relatively proximate the axis of incidence and/or that extends away from the addition location along the axis of incidence. Additionally or alternatively, the weighting function may be relatively lower within a region of the virtual geometric shape that is relatively distal the axis of incidence.

**[0105]** In some examples, the weighting function may be selected such that the amount of energy delivered, during the delivering at **130**, is proportional to an extent to which the axis of incidence extends within the overlap volume. In some examples, a region of the axis of incidence extends away from the addition location and to a surface of the virtual geometric shape. In such examples, the weighting function may be selected such that the amount of energy is proportional to a magnitude of the region of the axis of incidence that extends within the overlap volume, such that the amount of energy is relatively higher when an entirety of the region of the axis of incidence extends within the overlap volume, such that the amount of energy is relatively lower when less than the entirety of the region of the axis of incidence extends within the overlap volume, such that the amount of energy is relatively higher when the weighting function increases a calculated value of the overlap volume, and/or such that the amount of energy is relatively lower when the weighting function decreases the calculated value of the overlap volume.

**[0106]** An example of the weighting function is illustrated in FIGS. **17-18**. In FIGS. **17-18**, the weighting function is illustrated by a shading gradient **99** within virtual geometric shape **80**. More specifically, areas within virtual geometric shape **80** with a darker shading gradient **99** are weighted more heavily than areas within virtual geometric shape **80** with a lighter shading gradient **99**. As illustrated, this will cause the same size overlap volume **82** to be weighted more heavily when amount of energy **42** is directed toward edge **98**, as illustrated in FIG. **17**, when compared to when amount of energy **42** is directed away from edge **98**, as illustrated in FIG. **18**.

**[0107]** In some examples, the directionality parameter may be determined and/or established by a shape of the virtual geometric shape. As an example, and as discussed, the virtual geometric shape may include and/or be an elongate virtual geometric shape that may be characterized by an elongate axis that extends along the axis of incidence of the amount of energy. Examples of such virtual geometric shapes include ellipsoids, cylinders, and cones. In such examples, the shape of the virtual geometric shape may generate overlap volumes that preferentially weight regions

of the previously formed portion of the manufactured component that are relatively closer to the axis of incidence relative to regions of the previously formed portion of the manufactured component that are relatively farther from the axis of incidence.

**[0108]** Examples of how the shape of the virtual geometric shape may be utilized to preferentially weight regions of the previously formed portion of the manufactured component and/or may function as the directionality parameter are illustrated in FIGS. 17-20. A comparison between FIGS. 17-18 and FIGS. 19-20 illustrates that virtual geometric shapes **80** that define the elongate axis, such as the ellipsoids illustrated in FIGS. 19-20, may define overlap volumes **82** that emphasize axis of incidence **84**, when compared to the spherical virtual geometric shapes **80** that are illustrated in FIGS. 17-18. FIG. 19 also illustrates that such virtual geometric shapes that define the elongate axis also will define larger overlap volumes **82** when axis of incidence **84** is directed toward edge **98**, as illustrated in FIG. 19, when compared to when axis of incidence **84** is directed away from edge **98**, as illustrated in FIG. 20.

**[0109]** In some examples, the directionality parameter may include and/or be a nonuniform vector field. The nonuniform vector field may include a plurality of vectors that radially extends from the addition location, and the delivering at **130** may include delivering such that the amount of energy is based, at least in part, on the nonuniform vector field. More specifically, the amount of energy may be based, at least in part, on a number of vectors in the plurality of vectors that extends within the previously formed portion of the manufactured component. Thus, and as illustrated in FIGS. 21-22, a density of vectors **78** within various regions of a nonuniform vector field **76** may be varied in order to preferentially weight the amount of energy higher for certain relative orientations between amount of energy **42** and previously formed portion **92** of manufactured component **90**. As an example, nonuniform vector field **76** may be configured such that the number of vectors **78** that extend within previously formed portion **92** may be relatively higher when axis of incidence **84** points toward previously formed portion **92**, as illustrated in FIG. 21, and also such that the number of vectors **78** that extends within previously formed portion **92** may be relatively lower when axis of incidence **84** points away from previously formed portion **92**, as illustrated in FIG. 22.

**[0110]** As an example, the nonuniform vector field may include a high-density region, which includes a relatively higher density of the plurality of vectors, and a low-density region, which includes a remainder of the plurality of vectors. The high-density region is illustrated in FIGS. 21-22 and indicated at **77**. The low-density region is illustrated in FIGS. 21-22 and indicated at **79**. In some such examples, the axis of incidence may extend within and/or through the high-density region. This is illustrated in FIGS. 21-22, with axis of incidence **84** extending within and/or being surrounded by high-density region **77**. In some such examples, the high-density region may extend away from the addition location along the axis of incidence. This is also illustrated in FIGS. 21-22, with high-density region **77** extending away from addition location **94** along axis of incidence **84**.

**[0111]** In some examples, the energy application parameter also may include a process parameter. The process parameter may be based, at least in part, on at least one

process condition of and/or utilized during methods **100**. Examples of the at least one process condition include a thermal conductivity of the previously formed portion of the manufactured component, a layer thickness of the additional portion of the manufactured component, a gas flow rate of a gas provided to the addition location, and/or a granular volume, or average granular volume, of the feedstock material. Such a configuration may permit and/or facilitate adjustment of the amount of energy based upon the at least one process condition.

**[0112]** As an example, the thermal conductivity of the previously formed portion of the manufactured component may vary with location on the previously formed portion of the manufactured component. With this in mind, the amount of energy may be increased responsive to an increase in the thermal conductivity of the previously formed portion of the manufactured component and/or may be decreased responsive to a decrease in the thermal conductivity of the previously formed portion of the manufactured component. Such a configuration may permit and/or facilitate improved regulation of melt pool size and/or of material properties of the manufactured component despite variation, with location, in the rate at which the previously formed portion of the manufactured component dissipates energy and/or heat from the addition location.

**[0113]** Illustrative, non-exclusive examples of inventive subject matter according to the present disclosure are described in the following enumerated paragraphs:

**[0114]** A1. A method (**100**) of additively manufacturing a manufactured component (**90**), the method (**100**) comprising:

**[0115]** determining (**110**) an energy application parameter at an addition location (**94**) on a previously formed portion (**92**) of the manufactured component (**90**);

**[0116]** supplying (**120**) a feedstock material (**32**) to the addition location (**94**);

**[0117]** delivering (**130**), from an energy source (**40**) and to the addition location (**94**), an amount of energy (**42**) sufficient to form a melt pool (**38**) of the feedstock material (**32**) at the addition location (**94**), wherein the amount of energy (**42**) is based, at least in part, on the energy application parameter; and

**[0118]** consolidating (**140**) the melt pool (**38**) with the previously formed portion (**92**) of the manufactured component (**90**) to form an additional portion of the manufactured component (**90**).

**[0119]** A2. The method (**100**) of paragraph A1, wherein the determining (**110**) the energy application parameter includes determining the energy application parameter based, at least in part, on a rate of thermal energy dissipation at the addition location (**94**) and within the previously formed portion (**92**) of the manufactured component (**90**).

**[0120]** A3. The method (**100**) of any of paragraphs A1-A2, wherein the determining (**110**) the energy application parameter includes determining the energy application parameter based, at least in part, on an angle of incidence between the addition location (**94**) and the amount of energy (**42**).

**[0121]** A4. The method (**100**) of any of paragraphs A1-A3, wherein the determining (**110**) the energy application parameter includes determining the energy application parameter based, at least in part, on an



- efficiency of absorption of the amount of energy (42) by the previously formed portion (92) of the manufactured component (90).
- [0122] A5. The method (100) of any of paragraphs A1-A4, wherein the determining (110) the energy application parameter includes determining the energy application parameter based, at least in part, on a direction of absorption of the amount of energy (42) by the previously formed portion (92) of the manufactured component (90).
- [0123] A6. The method (100) of any of paragraphs A1-A5, wherein the determining (110) the energy application parameter includes determining the energy application parameter based, at least in part, on a material property of the feedstock material (32), optionally wherein the material property of the feedstock material (32) includes at least one of:
- [0124] (i) a latent heat of fusion of the feedstock material (32);
- [0125] (ii) a thermal conductivity of the feedstock material (32); and
- [0126] (iii) a melting point of the feedstock material (32).
- [0127] A7. The method (100) of any of paragraphs A1-A6, wherein the determining (110) the energy application parameter includes determining the energy application parameter based, at least in part, on a material property of the previously formed portion (92) of the manufactured component (90), optionally wherein the material property of the previously formed portion (92) of the manufactured component (90) includes at least one of:
- [0128] (i) a latent heat of fusion of the previously formed portion (92) of the manufactured component (90);
- [0129] (ii) a thermal conductivity of the previously formed portion (92) of the manufactured component (90); and
- [0130] (iii) a melting point of the previously formed portion (92) of the manufactured component (90).
- [0131] A8. The method (100) of any of paragraphs A1-A7, wherein the determining (110) the energy application parameter includes determining the energy application parameter based, at least in part, on a shape of the previously formed portion (92) of the manufactured component (90).
- [0132] A9. The method (100) of any of paragraphs A1-A8, wherein the determining (110) the energy application parameter includes determining the energy application parameter based, at least in part, on a temperature of the previously formed portion (92) of the manufactured component (90).
- [0133] A10. The method (100) of any of paragraphs A1-A9, wherein the determining (110) the energy application parameter includes determining the energy application parameter based, at least in part, on an environmental factor of an environment surrounding the previously formed portion (92) of the manufactured component (90), optionally wherein the environmental factor includes at least one of:
- [0134] (i) a material property of an environmental gas within the environment surrounding the previously formed portion (92) of the manufactured component (90); and
- [0135] (ii) a material property of a support platform (20) that supports the previously formed portion (92) of the manufactured component (90).
- [0136] A11. The method (100) of any of paragraphs A1-A10, wherein the supplying (120) the feedstock material (32) includes supplying a powder feedstock material, optionally wherein the powder feedstock material includes at least one of a metallic powder feedstock material, a polymeric powder feedstock material, and a composite powder feedstock material.
- [0137] A12. The method (100) of any of paragraphs A1-A11, wherein the supplying (120) the feedstock material (32) includes supplying a feedstock material filament, optionally wherein the feedstock material filament includes at least one of a wire, an electrically conductive filament, a metallic filament, a polymeric filament, and a composite filament.
- [0138] A13. The method (100) of any of paragraphs A1-A12, wherein the supplying (120) the feedstock material (32) includes distributing a layer of the feedstock material (32) on a surface, or an exposed upper surface, of the previously formed portion (92) of the manufactured component (90).
- [0139] A14. The method (100) of paragraph A13, wherein the supplying (120) the feedstock material (32) is prior to the delivering (130) the amount of energy (42).
- [0140] A15. The method (100) of any of paragraphs A1-A13, wherein the supplying (120) the feedstock material (32) includes supplying the feedstock material (32) concurrently with the delivering (130) the amount of energy (42).
- [0141] A16. The method (100) of paragraph A15, wherein the delivering (130) the amount of energy (42) includes delivering the amount of energy (42) via the feedstock material (32).
- [0142] A17. The method (100) of any of paragraphs A15-A16, wherein the delivering (130) the amount of energy (42) includes delivering the amount of energy (42) via an energy delivery mechanism (41) that is distinct from the feedstock material (32).
- [0143] A18. The method (100) of any of paragraphs A1-A17, wherein the amount of energy (42) is at least one of:
- [0144] (i) proportional to the energy application parameter;
- [0145] (ii) directly proportional to the energy application parameter; and
- [0146] (iii) linearly proportional to the energy application parameter.
- [0147] A19. The method (100) of any of paragraphs A1-A18, wherein the amount of energy (42) increases with an increase in the energy application parameter.
- [0148] A20. The method (100) of any of paragraphs A1-A19, wherein the amount of energy (42) decreases with a decrease in the energy application parameter.
- [0149] A21. The method (100) of any of paragraphs A1-A20, wherein the delivering (130) further includes selectively varying the amount of energy (42) based, at least in part, on the energy application parameter.
- [0150] A22. The method (100) of paragraph A21, wherein the selectively varying includes selectively varying at least one of:

- [0151] (i) a power consumption of the energy source (40);
- [0152] (ii) an intensity of energy incident upon the addition location (94);
- [0153] (iii) an exposure time of energy incident upon the addition location (94); and
- [0154] (iv) an application area over which the energy is incident upon the addition location (94).
- [0155] A23. The method (100) of any of paragraphs A1-A22, wherein the energy source (40) includes at least one of:
- [0156] (i) an electrical power source;
- [0157] (ii) a source of electromagnetic radiation;
- [0158] (iii) a laser beam source;
- [0159] (iv) an electron beam source; and
- [0160] (v) a heat source.
- [0161] A24. The method (100) of any of paragraphs A1-A23, wherein the amount of energy (42) includes at least one of:
- [0162] (i) an amount of electric energy;
- [0163] (ii) an amount of photon energy;
- [0164] (iii) an amount of electron beam energy; and
- [0165] (iv) an amount of heat.
- [0166] A25. The method (100) of any of paragraphs A1-A24, wherein the consolidating (430) the melt pool (38) includes cooling the melt pool (38) to below a melting temperature of the feedstock material (32).
- [0167] A26. The method (100) of any of paragraphs A1-A25, wherein the consolidating (140) the melt pool (38) includes solidifying the melt pool (38).
- [0168] A27. The method (100) of any of paragraphs A1-A26, wherein the consolidating (140) the melt pool (38) includes fusing the feedstock material (32), from the melt pool (38), to the previously formed portion (92) of the manufactured component (90).
- [0169] A28. The method (100) of any of paragraphs A1-A27, wherein the feedstock material (32) includes a/the powder feedstock material, and further wherein the supplying (120) the feedstock material (32) includes distributing a/the layer of the powder feedstock material on a/the surface, or an/the exposed upper surface, of the previously formed portion (92) of the manufactured component (90).
- [0170] A29. The method (100) of paragraph A28, wherein the addition location (94) is defined on the surface of the previously formed portion (92) of the manufactured component (90).
- [0171] A30. The method (100) of any of paragraphs A28-A29, wherein the distributing the layer of the powder feedstock material is performed prior to the delivering (130) the amount of energy (42).
- [0172] A31. The method (100) of any of paragraphs A1-A30, wherein the feedstock material (32) includes a/the powder feedstock material, and further wherein the supplying (120) the feedstock material (32) includes flowing the feedstock material (32) to the addition location (94) as a feedstock material stream.
- [0173] A32. The method (100) of paragraph A31, wherein the delivering (1300) the amount of energy (42) includes delivering the amount of energy (42) concurrently with the flowing the feedstock material (32).
- [0174] A33. The method (100) of any of paragraphs A1-A32, wherein the feedstock material (32) includes a/the feedstock material filament, and further wherein the supplying (120) the feedstock material (32) includes conveying the feedstock material filament to the addition location (94).
- [0175] A34. The method (100) of paragraph A33, wherein the delivering (130) the amount of energy (42) includes delivering the amount of energy (42) via the feedstock material filament.
- [0176] A35. The method (100) of any of paragraphs A33-A34, wherein the delivering (130) the amount of energy (42) includes delivering the amount of energy (42) via an/the energy delivery mechanism (41), which is distinct from the feedstock material (32).
- [0177] A36. The method (100) of any of paragraphs A33-A35, wherein the delivering (130) the amount of energy (42) includes delivering the amount of energy (42) concurrently with the conveying the feedstock material filament.
- [0178] A37. The method (100) of any of paragraphs A1-A36, wherein the addition location (94) is a first addition location (94), wherein the energy application parameter is a first energy application parameter, wherein the amount of energy (42) is a first amount of energy (42), wherein the melt pool (38) is a first melt pool (38), and further wherein the method (100) includes repeating (150) the method (100) by:
- [0179] Determining (110) a second energy application parameter at a second addition location (94) on the previously formed portion (92) of the manufactured component (90);
- [0180] Supplying (120) the feedstock material (32) to the second addition location (94);
- [0181] Delivering (130), from the energy source (40) and to the second addition location (94), a second amount of energy (42) sufficient to form a second melt pool (38) of the feedstock material (32) at the second addition location (94), wherein the second amount of energy (42) is based, at least in part, on the second energy application parameter; and
- [0182] Consolidating (140) the second melt pool (38) with the previously formed portion (92) of the manufactured component (90) to form a second additional portion of the manufactured component (90).
- [0183] A38. The method (100) of paragraph A37, wherein the second energy application parameter differs from the first energy application parameter, and further wherein the second amount of energy (42) differs from the first amount of energy (42).
- [0184] A39. The method (100) of any of paragraphs A37-A38, wherein a first melt pool size of the first melt pool (38) is equal, or at least substantially equal, to a second melt pool size of the second melt pool (38).
- [0185] A40. The method (100) of any of paragraphs A37-A39, wherein a first melt pool shape of the first melt pool (38) is equal, or at least substantially equal, to a second melt pool shape of the second melt pool (38).
- [0186] A41. The method (100) of any of paragraphs A37-A40, wherein the determining (110) the first energy application parameter and the determining (110) the second energy application parameter include determining such that the second melt pool (38) is within a threshold melt pool size range of the first melt pool (38), optionally wherein the threshold melt pool size range is at least one of:

- [0187] (i) at least 80%, at least 85%, at least 90%, at least 95%, at least 97.5%, or at least 99% of the first melt pool size; and
- [0188] (ii) at most 120%, at most 115%, at most 110%, at most 105%, at most 102.5%, or at most 101% of the first melt pool size.
- [0189] A42. The method (100) of any of paragraphs A37-A41, wherein the determining (110) the first energy application parameter and the determining (110) the second energy application parameter include determining such that a second penetration depth of the second melt pool (38) into the previously formed portion (92) of the manufactured component (90) is within a threshold penetration depth range of a first penetration depth of the first melt pool (38) into the previously formed portion (92) of the manufactured component (90), optionally wherein the threshold penetration depth range is at least one of:
- [0190] (i) at least 80%, at least 85%, at least 90%, at least 95%, at least 97.5%, or at least 99% of the first penetration depth; and
- [0191] (ii) at most 120%, at most 115%, at most 110%, at most 105%, at most 102.5%, or at most 101% of the first penetration depth.
- [0192] A43. The method (100) of any of paragraphs A1-A42, wherein the method (100) includes repeating (150) at least the determining (110), the delivering (130), and the consolidating (140) a plurality of times at a plurality of addition locations (94) to fully define the manufactured component (90).
- [0193] A44. The method (100) of paragraph A43, wherein the repeating (150) includes selecting the amount of energy (42) at each addition location (94) of the plurality of addition locations (94) based, at least in part, on a corresponding energy application parameter at each addition location (94).
- [0194] A45. The method (100) of paragraph A44, wherein the selecting includes at least one of:
- [0195] (i) increasing the amount of energy (42) at a given addition location of the plurality of addition locations (94), relative to another addition location (94) of the plurality of addition locations (94), responsive to an increase in the corresponding energy application parameter at the given addition location (94) relative to the other addition location (94);
- [0196] (ii) increasing the amount of energy (42) at the given addition location (94), relative to the other addition location (94), responsive to a decrease in the corresponding energy application parameter at the given addition location (94) relative to the other addition location (94);
- [0197] (iii) decreasing the amount of energy (42) at the given addition location (94), relative to the other addition location (94), responsive to a decrease in the corresponding energy application parameter at the given addition location (94) relative to the other addition location (94); and
- [0198] (iv) decreasing the amount of energy (42) at the given addition location (94), relative to the other addition location (94), responsive to an increase in the corresponding energy application parameter at the given addition location (94) relative to the other addition location (94).
- [0199] A46. The method (100) of any of paragraphs A43-A45, wherein, for a given addition location (94) of the plurality of addition locations (94), the repeating (150) further includes adjusting the amount of energy (42) based, at least in part, on an already delivered amount of energy (42) that already has been delivered to the previously formed portion (92) of the manufactured component (90).
- [0200] B1. The method (100) of any of paragraphs A1-A46, wherein the energy application parameter includes, or instead is, an overlap volume (82) between a virtual geometric shape (80), which is positioned at the addition location (94), and the previously formed portion (92) of the manufactured component (90).
- [0201] B2. The method (100) of paragraph B1, wherein a centroid of the virtual geometric shape (80) is positioned at the addition location (94).
- [0202] B3. The method (100) of any of paragraphs B1-B2, wherein, during the delivering (130), the amount of energy (42) is delivered to the addition location (94) along an axis of incidence (84), and further wherein the virtual geometric shape (80) is rotationally symmetric about the axis of incidence (84).
- [0203] B4. The method (100) of paragraph B3, wherein the virtual geometric shape (80) defines an elongate axis, and further wherein the elongate axis extends along the axis of incidence (84).
- [0204] B5. The method (100) of any of paragraphs B1-B4, wherein the virtual geometric shape (80) at least one of:
- [0205] (i) has a predetermined size;
- [0206] (ii) has a predetermined volume;
- [0207] (iii) has a fixed size; and
- [0208] (iv) has a fixed volume.
- [0209] B6. The method (100) of any of paragraphs B1-B5, wherein the virtual geometric shape (80) is a spherical, or at least partially spherical, virtual geometric shape (80).
- [0210] B7. The method (100) of any of paragraphs B1-B6, wherein the overlap volume (82) is a partially spherical overlap volume (82).
- [0211] B8. The method (100) of any of paragraphs B1-B7, wherein the virtual geometric shape (80) is an ellipsoidal, or at least partially ellipsoidal, virtual geometric shape (80).
- [0212] B9. The method (100) of any of paragraphs B1-B8, wherein the overlap volume (82) is a partially ellipsoidal overlap volume (82).
- [0213] B10. The method (100) of any of paragraphs B1-B9, wherein the virtual geometric shape (80) defines a virtual geometric shape volume, and further wherein the overlap volume (82) is at most half of the virtual geometric shape volume.
- [0214] B11. The method (100) of any of paragraphs B1-1310, wherein the method (100) further includes varying a position of the addition location (94) on the previously formed portion (92) of the manufactured component (90) to define a/the plurality of addition locations (94), and further wherein, during the varying the method (100) includes repeating (150) at least the determining (110), the delivering (130), and the consolidating (140) a plurality of times at the plurality of addition locations (94) to fully define the manufactured component (90).

- [0215] B12. The method (100) of paragraph B11, wherein the repeating (150) the determining (110) includes determining a corresponding overlap volume (82) at each addition location (94) of the plurality of addition locations (94).
- [0216] B13. The method (100) of paragraph B12, wherein the repeating (150) the delivering (130) includes delivering a corresponding amount of energy (42) at each addition location (94) of the plurality of addition locations (94).
- [0217] B14. The method (100) of paragraph B13, wherein, responsive to the corresponding overlap volume (82) at a given addition location (94) of the plurality of addition locations (94) decreasing from the corresponding overlap volume (82) at a prior addition location (94) of the plurality of addition locations (94), the repeating (150) the delivering (130) includes decreasing the corresponding amount of energy (42) delivered at the given addition location (94) relative to the corresponding amount of energy (42) delivered at the prior addition location (94).
- [0218] B15. The method (100) of any of paragraphs B13-B14, wherein, responsive to the corresponding overlap volume (82) at a given addition location (94) of the plurality of addition locations (94) increasing from the corresponding overlap volume (82) at a prior addition location (94) of the plurality of addition locations (94), the repeating the delivering includes increasing the corresponding amount of energy (42) delivered at the given addition location (94) relative to the corresponding amount of energy (42) delivered at the prior addition location (94).
- [0219] B15.1 The method (100) of any of paragraphs B13-B15, wherein the corresponding amount of energy (42) is proportional to the corresponding overlap volume (82).
- [0220] B16. The method (100) of any of paragraphs B1-B15.1, wherein the overlap volume (82) is a first overlap volume (82), and further wherein the overlap volume (82) includes a second overlap volume (88) between the virtual geometric shape (80) and at least one environmental component (89) in an/the environment surrounding the previously formed portion (92) of the manufactured component (90).
- [0221] B17. The method (100) of paragraph B16, wherein the at least one environmental component (89) includes at least one of:
- [0222] (i) a/the support platform (20) for the previously formed portion (92) of the manufactured component (90);
- [0223] (ii) the feedstock material (32);
- [0224] (iii) a/the environmental gas within the environment surrounding the previously formed portion (92) of the manufactured component (90);
- [0225] (iv) a region (96) of the manufactured component (90) that is discontinuous with the previously formed portion (92) of the manufactured component (90) within the overlap volume (82); and
- [0226] (v) a region (96) of another manufactured component (90) that is discontinuous with the previously formed portion (92) of the manufactured component (90) within the overlap volume (82).
- [0227] B18. The method (100) of any of paragraphs B16-B17, wherein at least one of:
- [0228] (i) the amount of energy (42) is based, at least in part, on both the first overlap volume (82) and the second overlap volume (88), optionally wherein the amount of energy (42) is weighted differently for the first overlap volume (82) and for the second overlap volume (88); and
- [0229] (ii) the amount of energy (42) is based, at least in part, on only the first overlap volume (82).
- [0230] C1. The method (100) of any of paragraphs A1-618, wherein the energy application parameter includes, or instead is, an intersection area relationship, wherein the intersection area relationship describes an area of intersection (70) between the previously formed portion (92) of the manufactured component (90) and a surface of a/the virtual geometric shape (80), which is positioned at the addition location (94), as a function of a size parameter (81) of the virtual geometric shape (80).
- [0231] C2. The method (100) of paragraph C1, wherein the intersection area relationship includes at least one of:
- [0232] (i) a plot of the area of intersection (70) as a function of the size parameter (81);
- [0233] (ii) tabulated values of the area of intersection (70) and corresponding values of the size parameter (81); and
- [0234] (iii) a functional relationship between the area of intersection (70) and the size parameter (81).
- [0235] C3. The method (100) of any of paragraphs C1-C2, wherein, for a given size parameter (81) of the virtual geometric shape (80), a corresponding area of intersection (70) quantifies a surface area of an outer surface of the virtual geometric shape (80) that extends within the previously formed portion (92) of the manufactured component (90).
- [0236] C4. The method (100) of any of paragraphs C1-C3, wherein the virtual geometric shape (80) has a constant, or at least substantially constant, shape.
- [0237] C5. The method (100) of any of paragraphs C1-C4, wherein, for a given size parameter (81), the virtual geometric shape (80) has a given virtual geometric shape volume that corresponds to the given size parameter (81).
- [0238] C6. The method (100) of any of paragraphs C1-05, wherein the virtual geometric shape (80) is a/the spherical, or at least partially spherical, virtual geometric shape (80).
- [0239] C7. The method (100) of any of paragraphs C1-C6, wherein the size parameter (81) is indicative of at least one of:
- [0240] (i) a volume of the virtual geometric shape (80); and
- [0241] (ii) a surface area of the virtual geometric shape (80).
- [0242] C8. The method (100) of any of paragraphs C1-C7, wherein the size parameter (81) includes at least one of:
- [0243] (i) a radius of the virtual geometric shape (80);
- [0244] (ii) a diameter of the virtual geometric shape (80);
- [0245] (iii) an effective radius of the virtual geometric shape (80); and
- [0246] (iv) an effective diameter of the virtual geometric shape (80).

- [0247] C9. The method (100) of any of paragraphs C1-C8, wherein the determining (110) further includes generating the intersection area relationship (70).
- [0248] C10. The method (100) of paragraph C9, wherein the generating includes quantifying the area of intersection (70) between the previously formed portion (92) of the manufactured component (90) and the surface of the virtual geometric shape (80) for a plurality of different size parameters (81).
- [0249] C11. The method (100) of any of paragraphs C9-C10, wherein the generating includes:
- [0250] (i) virtually positioning the virtual geometric shape (80) at the addition location (94);
- [0251] (ii) determining, for a/the plurality of different size parameters (81) of the virtual geometric shape (80), a corresponding plurality of areas of intersection (70) between the previously formed portion (92) of the manufactured component (90) and the surface of the virtual geometric shape (80); and
- [0252] (iv) producing the intersection area relationship based, at least in part, on the plurality of different size parameters (81) and the corresponding plurality of areas of intersection (70).
- [0253] C12. The method (100) of paragraph C11, wherein the virtually positioning includes virtually positioning a/the centroid of the virtual geometric shape (80) at the addition location (94).
- [0254] C13. The method (100) of any of paragraphs C11-C12, wherein the producing the intersection area relationship includes at least one of:
- [0255] (i) producing a/the plot of the area of intersection (70) as a function of the size parameter (81);
- [0256] (ii) producing tabulated values of the area of intersection (70) and corresponding values of the size parameter (81);
- [0257] (iii) producing a/the functional relationship between the area of intersection (70) and the size parameter (81);
- [0258] (iv) determining a slope of the area of intersection (70) as the function of the size parameter (81);
- [0259] (v) determining an average slope of the area of intersection (70) as the function of the size parameter (81);
- [0260] (vi) determining a minimum slope of the area of intersection (70) as the function of the size parameter (81); and
- [0261] (vii) determining the slope of the area of intersection (70) as the function of the size parameter (81) for a specific value of the size parameter (81).
- [0262] C14. The method (100) of any of paragraphs C9-C13, wherein, during the generating, the method further includes omitting, from the area of intersection (70), intersection of the surface of the virtual geometric shape (80) with a region (96) of the previously formed portion (92) of the manufactured component (90) that is not contiguous with a region of the previously formed portion (92) of the manufactured component (90) that includes the addition location (94).
- [0263] C15. The method (100) of any of paragraphs C1-C14, wherein the method (100) further includes decreasing the amount of energy (42) when a rate of change of the intersection area relationship is less than a threshold rate of change.
- [0264] C16. The method (100) of any of paragraphs C1-C15, wherein the method (100) further includes increasing the amount of energy (42) when a/the rate of change of the intersection area relationship is greater than a/the threshold rate of change.
- [0265] C17. The method (100) of any of paragraphs C1-C16, wherein the method (100) further includes changing the amount of energy (42) proportionate to a/the rate of change of the intersection area relationship.
- [0266] C18. The method (100) of any of paragraphs C1-C17, wherein, when a/the rate of change of the intersection area relationship is less than a/the threshold rate of change, the method (100) further includes determining that the addition location (94) is proximate a gap (72) within the previously formed portion (92) of the manufactured component (90).
- [0267] D1. The method (100) of any of paragraphs A1-C18, wherein, during the delivering (130), the amount of energy (42) is delivered to the addition location (94) along an/the axis of incidence (84), and further wherein the energy application parameter includes, or instead is, a directionality parameter that is based, at least in part, on the axis of incidence (84).
- [0268] D2. The method (100) of paragraph D1, wherein the delivering (130) includes delivering such that the amount of energy (42) relatively increases when the directionality parameter indicates that the amount of energy (42) is directed toward an edge (98) of the previously formed portion (92) of the manufactured component (90) and an underlying surface of the previously formed portion (92) of the manufactured component (90), which partially defines the edge (98), is relatively proximate the axis of incidence (84).
- [0269] D3. The method (100) of any of paragraphs D1-D2, wherein the delivering (130) includes delivering such that the amount of energy (42) decreases when the directionality parameter indicates that the amount of energy (42) is directed toward an/the edge (98) of the previously formed portion (92) of the manufactured component (90) and an/the underlying surface of the previously formed portion (92) of the manufactured component (90), which partially defines the edge (98), is relatively distal the axis of incidence (84).
- [0270] D4. The method (100) of any of paragraphs D1-D3, wherein, for a given addition location (94), the delivering (130) includes delivering such that:
- [0271] (i) the amount of energy (42) is relatively higher when the directionality parameter indicates that the amount of energy (42) is directed toward an/the edge (98) of the previously formed portion (92) of the manufactured component (90) and an/the underlying surface of the previously formed portion (92) of the manufactured component (90), which partially defines the edge (98), is relatively proximate the axis of incidence (84); and
- [0272] (ii) the amount of energy (42) is relatively lower when the directionality parameter indicates that the amount of energy (42) is directed toward the edge (98) of the previously formed portion (92) of the manufactured component (90) and the underlying surface of the previously formed portion (92) of the manufactured component (90), which partially defines the edge (98), is relatively distal the axis of incidence (84).

- [0273] D5. The method (100) of any of paragraphs D1-D4, wherein the energy application parameter further includes a process parameter that is based, at least in part, on at least one process condition of the method (100).
- [0274] D6. The method (100) of paragraph D5, wherein the at least one process condition includes at least one of:
- [0275] (i) a thermal conductivity of the previously formed portion (92) of the manufactured component (90);
- [0276] (ii) a layer thickness of the additional portion of the manufactured component (90);
- [0277] (iii) a gas flow rate of a gas provided to the addition location (94); and
- [0278] (iv) a granular volume, or average granular volume, of the feedstock material (32).
- [0279] D7. The method (100) of any of paragraphs D1-D6 when dependent from any of paragraphs B1-B18, wherein the directionality parameter includes a weighting function, which is applied to an internal volume of the virtual geometric shape (80).
- [0280] D8. The method (100) of paragraph D7, wherein:
- [0281] (i) the weighting function is relatively higher within a region of the virtual geometric shape (80) that is relatively proximate the axis of incidence (84) and extends away from the addition location (94) along the axis of incidence (84); and
- [0282] (ii) the weighting function is relatively lower within a region of the virtual geometric shape (80) that is relatively distal the axis of incidence (84).
- [0283] D9. The method (100) of any of paragraphs D7-D8, wherein the weighting function is selected such that the amount of energy (42) is proportional to an extent to which the axis of incidence (84) extends within the overlap volume (82).
- [0284] D10. The method (100) of any of paragraphs D7-D9, wherein a region of the axis of incidence (84) extends away from the addition location (94) and to a surface of the virtual geometric shape (80), and further wherein the weighting function is selected such that at least one of:
- [0285] (i) the amount of energy (42) is proportional to a magnitude of the region of the axis of incidence (84) that extends within the overlap volume (82);
- [0286] (ii) the amount of energy (42) is relatively higher when an entirety of the region of the axis of incidence (84) extends within the overlap volume (82);
- [0287] (iii) the amount of energy (42) is relatively lower when less than the entirety of the region of the axis of incidence (84) extends within the overlap volume (82);
- [0288] (iv) the amount of energy (42) is relatively higher when the weighting function increases a calculated value of the overlap volume (82); and
- [0289] (v) the amount of energy (42) is relatively lower when the weighting function decreases a/the calculated value of the overlap volume (82).
- [0290] D11. The method (100) of any of paragraphs D1-D10 when dependent from any of paragraphs B1-B18, wherein the directionality parameter includes a shape of the virtual geometric shape (80).
- [0291] D12. The method (100) of paragraph D11, wherein the shape is an elongate virtual geometric shape (80) that is characterized by an/the elongate axis, which extends along the axis of incidence (84).
- [0292] D13. The method (100) of any of paragraphs D11-D12, wherein the virtual geometric shape (80) includes at least one of an ellipsoid and a cylinder.
- [0293] D14. The method (100) of any of paragraphs D1-D13, wherein the directionality parameter includes a nonuniform vector field (76), which includes a plurality of vectors (78) that radially extends from the addition location (94), and further wherein the delivering (130) includes delivering such that the amount of energy (42) is based, at least in part, on a number of vectors (78) in the plurality of vectors (78) that extends within the previously formed portion (92) of the manufactured component (90).
- [0294] D15. The method (100) of paragraph D14, wherein the nonuniform vector field (76) includes a high-density region (77), which includes a relatively higher density of vectors (78) of the plurality of vectors (78), and a low-density region (79), which includes a remainder of the plurality of vectors (78).
- [0295] D16. The method (100) of paragraph D15, wherein the axis of incidence (84) extends within the high-density region (77).
- [0296] D17. The method (100) of any of paragraphs D15-D16, wherein the high-density region (77) extends away from the addition location (94) along the axis of incidence (84).
- [0297] E1. An additive manufacturing system (10) for additively manufacturing a manufactured component (90), the additive manufacturing system (10) comprising:
- [0298] a support platform (20) configured to support the manufactured component (90) during additive manufacture of the manufactured component (90);
- [0299] a feedstock supply system (30) configured to supply a feedstock material (32) to an addition location (94) of the manufactured component (90);
- [0300] an energy source (40) configured to deliver an amount of energy (42) to the addition location (94);
- [0301] and a controller (60) programmed to control the operation of the additive manufacturing system (10) according to the method (100) of any of paragraphs A1-D17.
- [0302] E2. The system (10) of paragraph E1, wherein the feedstock supply system (30) includes at least one of:
- [0303] (i) a powder supply system configured to supply the feedstock material (32) in the form of a feedstock material powder; and
- [0304] (ii) a filament supply system configured to supply the feedstock material (32) in the form of a feedstock material filament.
- [0305] E3. The system (10) of any of paragraphs E1-E2, wherein the energy source (40) includes at least one of:
- [0306] (i) an electrical power source;
- [0307] (ii) a source of electromagnetic radiation;
- [0308] (iii) a laser beam source;
- [0309] (iv) an electron beam source; and
- [0310] (v) a heat source.
- [0311] F1. Non-transitory computer readable storage media (62) including computer-executable instructions

that, when executed, direct an additive manufacturing system (10) to perform the method (100) of any of paragraphs A1-D17.

**[0312]** As used herein, the terms “selective” and “selectively,” when modifying an action, movement, configuration, or other activity of one or more components or characteristics of an apparatus, mean that the specific action, movement, configuration, or other activity is a direct or indirect result of user manipulation of an aspect of, or one or more components of, the apparatus.

**[0313]** As used herein, the terms “adapted” and “configured” mean that the element, component, or other subject matter is designed and/or intended to perform a given function. Thus, the use of the terms “adapted” and “configured” should not be construed to mean that a given element, component, or other subject matter is simply “capable of” performing a given function but that the element, component, and/or other subject matter is specifically selected, created, implemented, utilized, programmed, and/or designed for the purpose of performing the function. It is also within the scope of the present disclosure that elements, components, and/or other recited subject matter that is recited as being adapted to perform a particular function may additionally or alternatively be described as being configured to perform that function, and vice versa. Similarly, subject matter that is recited as being configured to perform a particular function may additionally or alternatively be described as being operative to perform that function.

**[0314]** As used herein, the phrase “at least one,” in reference to a list of one or more entities should be understood to mean at least one entity selected from any one or more of the entity in the list of entities, but not necessarily including at least one of each and every entity specifically listed within the list of entities and not excluding any combinations of entities in the list of entities. This definition also allows that entities may optionally be present other than the entities specifically identified within the list of entities to which the phrase “at least one” refers, whether related or unrelated to those entities specifically identified. Thus, as a non-limiting example, “at least one of A and B” (or, equivalently, “at least one of A or B,” or, equivalently “at least one of A and/or B”) may refer, in one embodiment, to at least one, optionally including more than one, A, with no B present (and optionally including entities other than B); in another embodiment, to at least one, optionally including more than one, B, with no A present (and optionally including entities other than A); in yet another embodiment, to at least one, optionally including more than one, A, and at least one, optionally including more than one, B (and optionally including other entities). In other words, the phrases “at least one,” “one or more,” and “and/or” are open-ended expressions that are both conjunctive and disjunctive in operation. For example, each of the expressions “at least one of A, B, and C,” “at least one of A, B, or C,” “one or more of A, B, and C,” “one or more of A, B, or C” and “A, B, and/or C” may mean A alone, B alone, C alone, A and B together, A and C together, B and C together, A, B, and C together, and optionally any of the above in combination with at least one other entity.

**[0315]** The various disclosed elements of apparatuses and steps of methods disclosed herein are not required to all apparatuses and methods according to the present disclosure, and the present disclosure includes all novel and non-obvious combinations and subcombinations of the vari-

ous elements and steps disclosed herein. Moreover, one or more of the various elements and steps disclosed herein may define independent inventive subject matter that is separate and apart from the whole of a disclosed apparatus or method. Accordingly, such inventive subject matter is not required to be associated with the specific apparatuses and methods that are expressly disclosed herein, and such inventive subject matter may find utility in apparatuses and/or methods that are not expressly disclosed herein.

**[0316]** As used herein, the phrase, “for example,” the phrase, “as an example,” and/or simply the term “example,” when used with reference to one or more components, features, details, structures, embodiments, and/or methods according to the present disclosure, are intended to convey that the described component, feature, detail, structure, embodiment, and/or method is an illustrative, non-exclusive example of components, features, details, structures, embodiments, and/or methods according to the present disclosure. Thus, the described component, feature, detail, structure, embodiment, and/or method is not intended to be limiting, required, or exclusive/exhaustive; and other components, features, details, structures, embodiments, and/or methods, including structurally and/or functionally similar and/or equivalent components, features, details, structures, embodiments, and/or methods, are also within the scope of the present disclosure.

**[0317]** As used herein, “at least substantially,” when modifying a degree or relationship, may include not only the recited “substantial” degree or relationship, but also the full extent of the recited degree or relationship. A substantial amount of a recited degree or relationship may include at least 75% of the recited degree or relationship. For example, an object that is at least substantially formed from a material includes objects for which at least 75% of the objects are formed from the material and also includes objects that are completely formed from the material. As another example, a first length that is at least substantially as long as a second length includes first lengths that are within 75% of the second length and also includes first lengths that are as long as the second length.

1. A method of additively manufacturing a manufactured component, the method comprising:

- determining an energy application parameter at an addition location on a previously formed portion of the manufactured component;
  - supplying a feedstock material to the addition location;
  - delivering, from an energy source and to the addition location, an amount of energy sufficient to form a melt pool of the feedstock material at the addition location, wherein the amount of energy is based, at least in part, on the energy application parameter; and
  - consolidating the melt pool with the previously formed portion of the manufactured component to form an additional portion of the manufactured component;
- wherein, during the delivering, the amount of energy is delivered to the addition location along an axis of incidence, and further wherein the energy application parameter includes a directionality parameter that is based, at least in part, on the axis of incidence.

2. The method of claim 1, wherein the delivering includes delivering such that the amount of energy relatively increases when the directionality parameter indicates that the amount of energy is directed toward an edge of the previously formed portion of the manufactured component

and an underlying surface of the previously formed portion of the manufactured component, which partially defines the edge, is relatively proximate the axis of incidence.

3. The method of claim 1, wherein the delivering includes delivering such that the amount of energy decreases when the directionality parameter indicates that the amount of energy is directed toward an edge of the previously formed portion of the manufactured component and an underlying surface of the previously formed portion of the manufactured component, which partially defines the edge, is relatively distal the axis of incidence.

4. The method of claim 1, wherein, for a given addition location, the delivering includes delivering such that:

- (i) the amount of energy is relatively higher when the directionality parameter indicates that the amount of energy is directed toward an edge of the previously formed portion of the manufactured component and an underlying surface of the previously formed portion of the manufactured component, which partially defines the edge, is relatively proximate the axis of incidence; and
- (ii) the amount of energy is relatively lower when the directionality parameter indicates that the amount of energy is directed toward the edge of the previously formed portion of the manufactured component and the underlying surface of the previously formed portion of the manufactured component is relatively distal the axis of incidence.

5. The method of claim 1, wherein the energy application parameter further includes a process parameter that is based, at least in part, on at least one process condition of the method.

6. The method of claim 5, wherein the at least one process condition includes at least one of:

- (i) a thermal conductivity of the previously formed portion of the manufactured component;
- (ii) a layer thickness of the additional portion of the manufactured component;
- (iii) a gas flow rate of a gas provided to the addition location; and
- (iv) a granular volume of the feedstock material.

7. The method of claim 1, wherein the energy application parameter further includes an overlap volume between a virtual geometric shape, which is positioned at the addition location, and the previously formed portion of the manufactured component.

8. The method of claim 7, wherein the directionality parameter includes a weighting function, which is applied to an internal volume of the virtual geometric shape.

9. The method of claim 8, wherein:

- (i) the weighting function is relatively higher within a region of the virtual geometric shape that is relatively proximate the axis of incidence and extends away from the addition location along the axis of incidence; and
- (ii) the weighting function is relatively lower within a region of the virtual geometric shape that is relatively distal the axis of incidence.

10. The method of claim 8, wherein the weighting function is selected such that the amount of energy is proportional to an extent to which the axis of incidence extends within the overlap volume.

11. The method of claim 8, wherein a region of the axis of incidence extends away from the addition location and to

a surface of the virtual geometric shape, and further wherein the weighting function is selected such that at least one of:

- (i) the amount of energy is proportional to a magnitude of the region of the axis of incidence that extends within the overlap volume;
- (ii) the amount of energy is relatively higher when an entirety of the region of the axis of incidence extends within the overlap volume;
- (iii) the amount of energy is relatively lower when less than the entirety of the region of the axis of incidence extends within the overlap volume;
- (iv) the amount of energy is relatively higher when the weighting function increases a calculated value of the overlap volume; and
- (v) the amount of energy is relatively lower when the weighting function decreases the calculated value of the overlap volume.

12. The method of claim 7, wherein the directionality parameter includes a shape of the virtual geometric shape.

13. The method of claim 12, wherein the shape is an elongate virtual geometric shape that is characterized by an elongate axis, which extends along the axis of incidence.

14. The method of claim 12, wherein the virtual geometric shape includes at least one of an ellipsoid and a cylinder.

15. The method of claim 1, wherein the directionality parameter includes a nonuniform vector field, which includes a plurality of vectors that radially extends from the addition location, and further wherein the delivering includes delivering such that the amount of energy is based, at least in part, on a number of vectors in the plurality of vectors that extends within the previously formed portion of the manufactured component.

16. The method of claim 15, wherein the nonuniform vector field include a high-density region, which includes a relatively higher density of vectors of the plurality of vectors, and a low-density region, which includes a remainder of the plurality of vectors.

17. The method of claim 16, wherein the axis of incidence extends within the high-density region.

18. The method of claim 16, wherein the high-density region extends away from the addition location along the axis of incidence.

19. An additive manufacturing system for additively manufacturing a manufactured component, the additive manufacturing system comprising:

- a support platform configured to support the manufactured component during additive manufacture of the manufactured component;
- a feedstock supply system configured to supply a feedstock material to an addition location of the manufactured component;
- an energy source configured to deliver an amount of energy to the addition location; and
- a controller programmed to control operation of the additive manufacturing system according to the method of claim 1.

20. Non-transitory computer readable storage media including computer-executable instructions that, when executed, direct an additive manufacturing system to perform the method of claim 1.