



(19) **United States**
 (12) **Patent Application Publication** (10) **Pub. No.: US 2023/0346187 A1**
 NIEN et al. (43) **Pub. Date: Nov. 2, 2023**

(54) **CLEANING ROBOT, CLEANING ROBOT SYSTEM AND OPERATING METHOD THEREOF**

B60L 53/36 (2006.01)
G05D 1/02 (2006.01)
H02J 7/00 (2006.01)

(71) Applicant: **PixArt Imaging Inc.**, Hsin-Chu County (TW)

(52) **U.S. Cl.**
 CPC *A47L 11/4011* (2013.01); *A47L 9/2873* (2013.01); *B60L 53/36* (2019.02); *G05D 1/0225* (2013.01); *G05D 1/0234* (2013.01); *H02J 7/0042* (2013.01); *A47L 2201/022* (2013.01); *A47L 2201/04* (2013.01); *G05D 2201/0203* (2013.01)

(72) Inventors: **Chu-Hung NIEN**, Hsin-Chu County (TW); **Chao-Chien HUANG**, Hsin-Chu County (TW); **Shu-Sian YANG**, Hsin-Chu County (TW); **Wei-Feng WEI**, Hsin-Chu County (TW)

(21) Appl. No.: **18/206,587**

(22) Filed: **Jun. 6, 2023**

(57) **ABSTRACT**

Related U.S. Application Data

(63) Continuation of application No. 16/386,563, filed on Apr. 17, 2019, now Pat. No. 11,712,143.

Foreign Application Priority Data

Sep. 11, 2018 (CN) 201811056712.X

Publication Classification

(51) **Int. Cl.**
A47L 9/28 (2006.01)
A47L 11/40 (2006.01)

There is provided a cleaning robot system including a charging station and a cleaning robot. The charging station includes multiple positioning beacons. The cleaning robot includes an image sensor and a processor. The image sensor is used to acquire light generated by the multiple positioning beacons on the charging station and generate an image frame. The processor is electrically connected to the image sensor, and used to calculate a relative position with respect to the charging station according to beacon images of the multiple positioning beacons in the image frame to determine a recharge path accordingly.

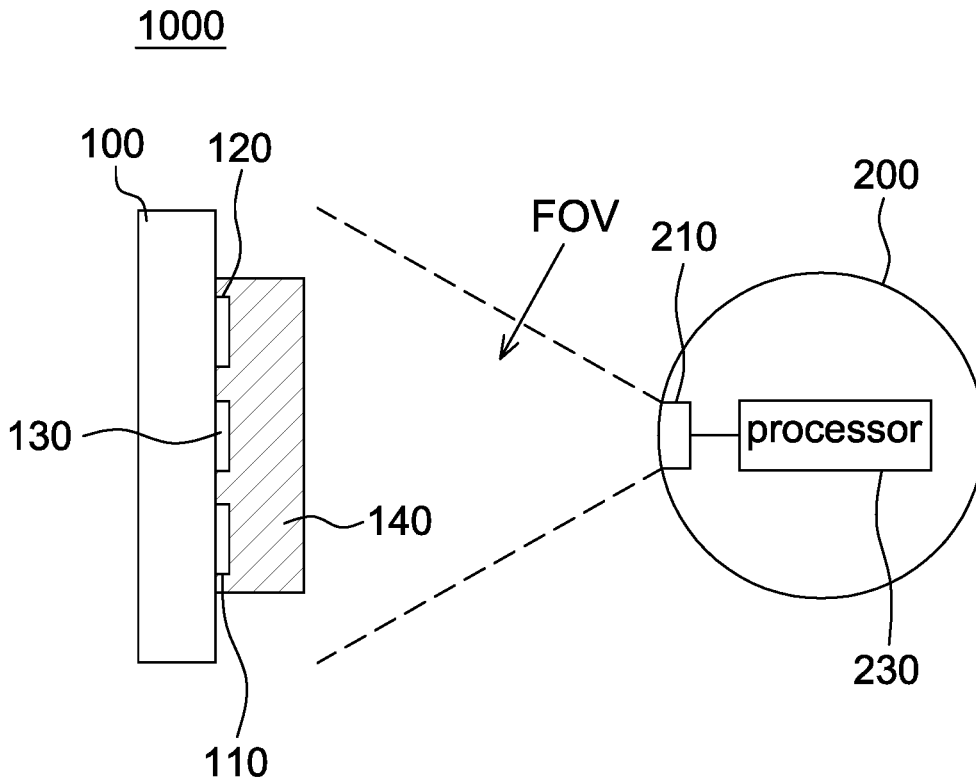

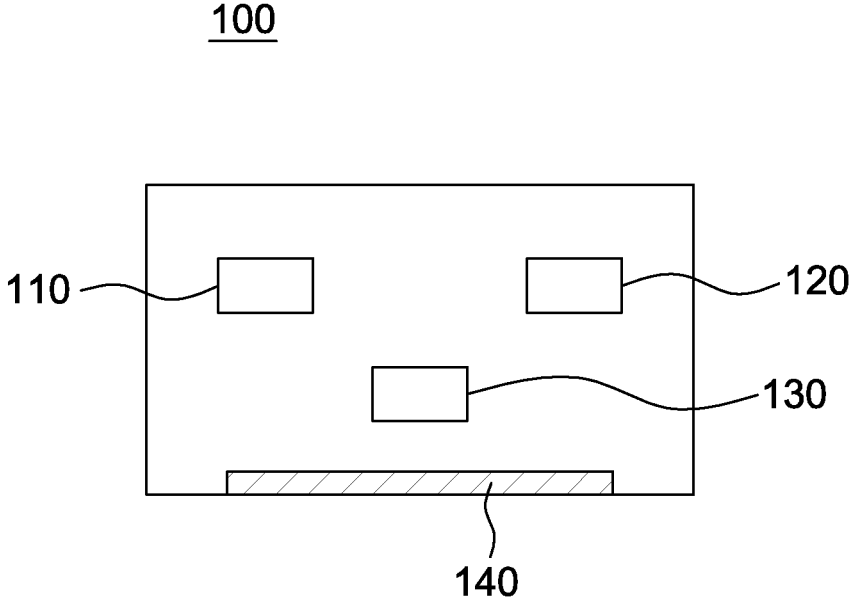

FIG. 1

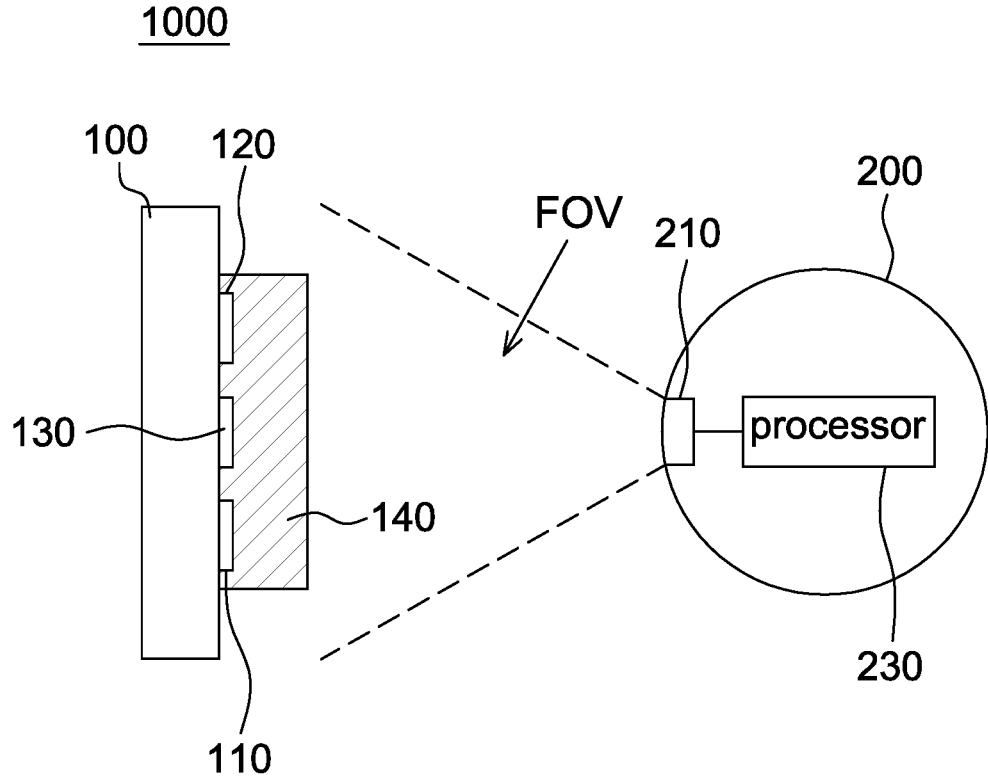

FIG. 2

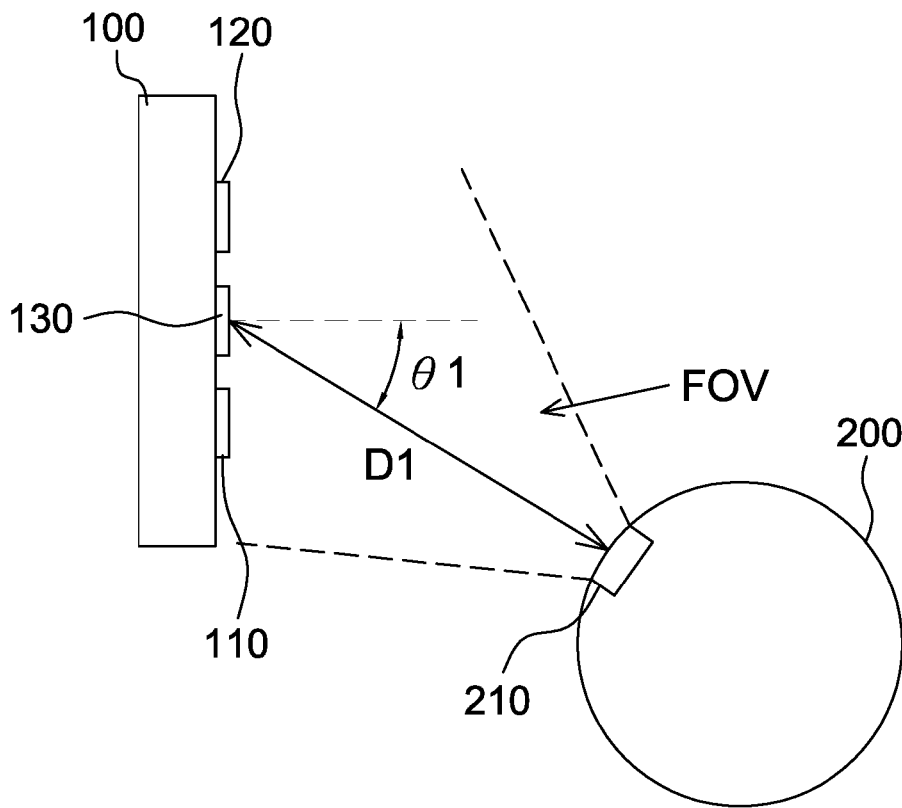

FIG. 3

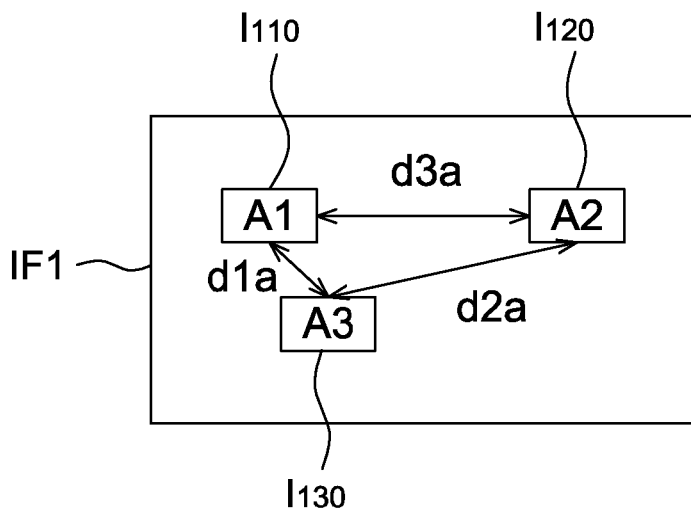

FIG. 4

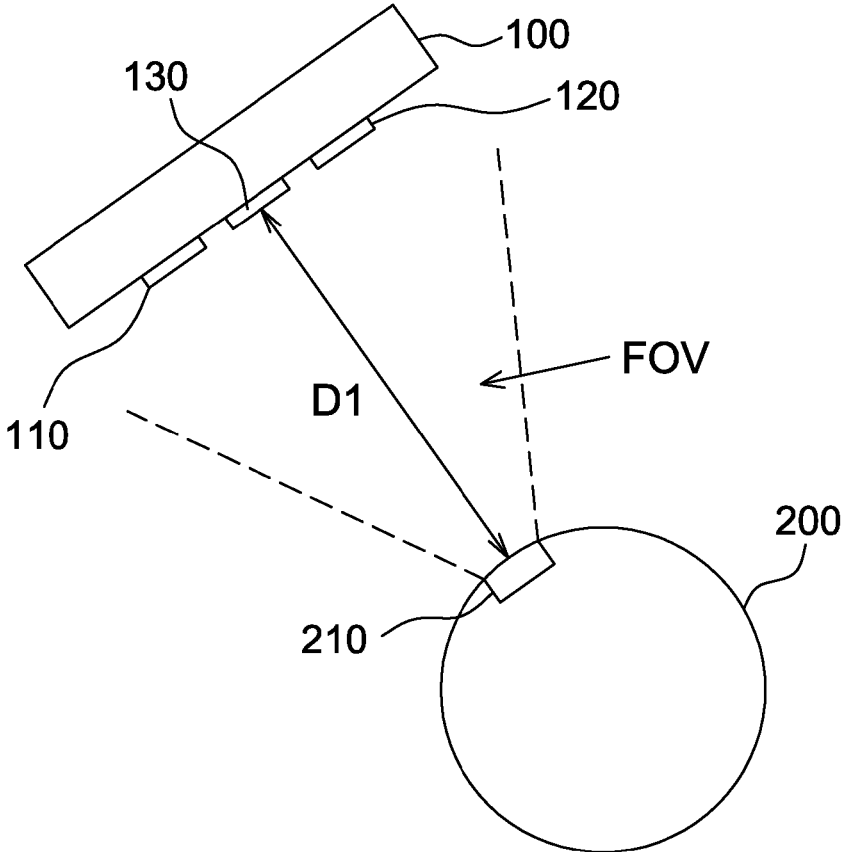

FIG. 5

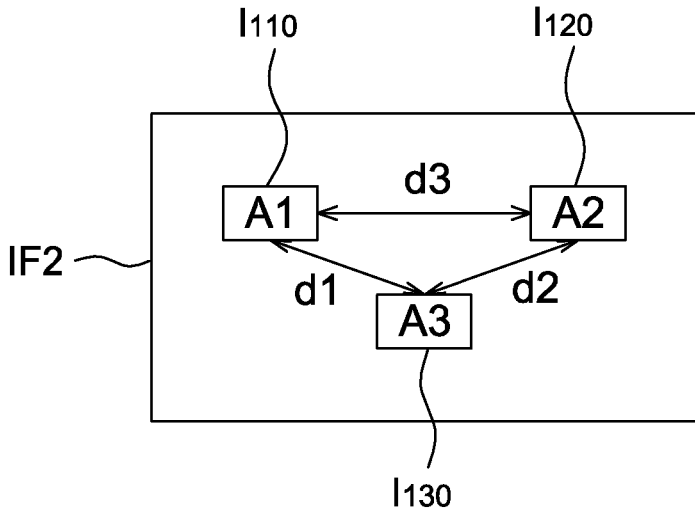

FIG. 6

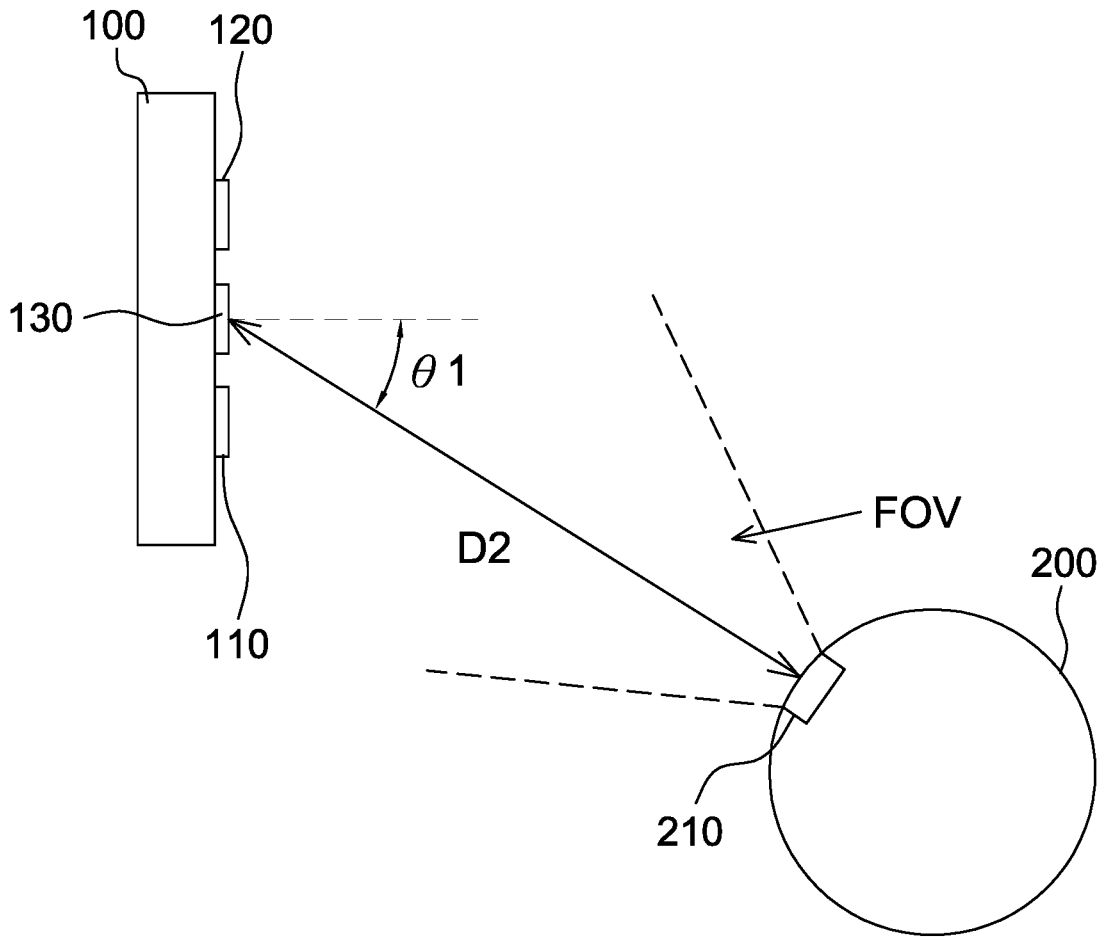

FIG. 7

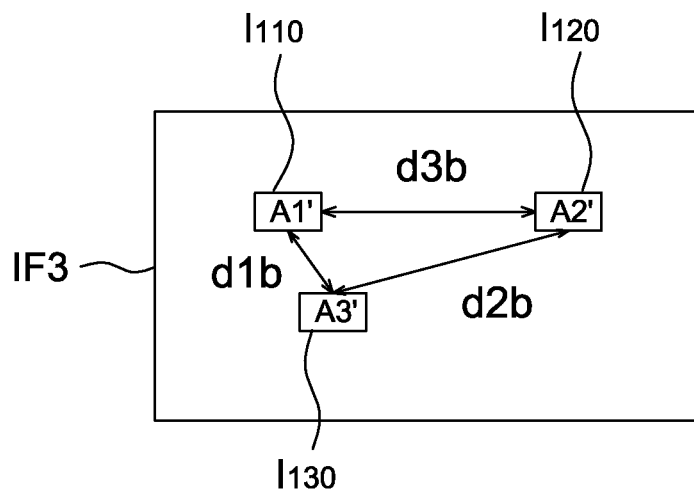

FIG. 8

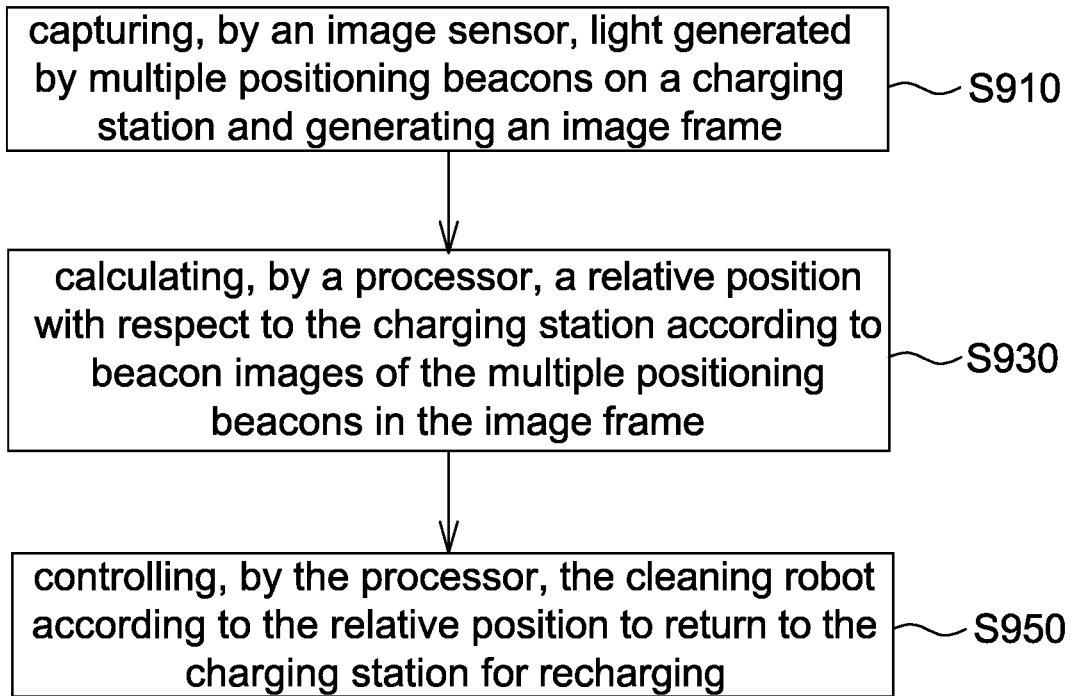

FIG. 9

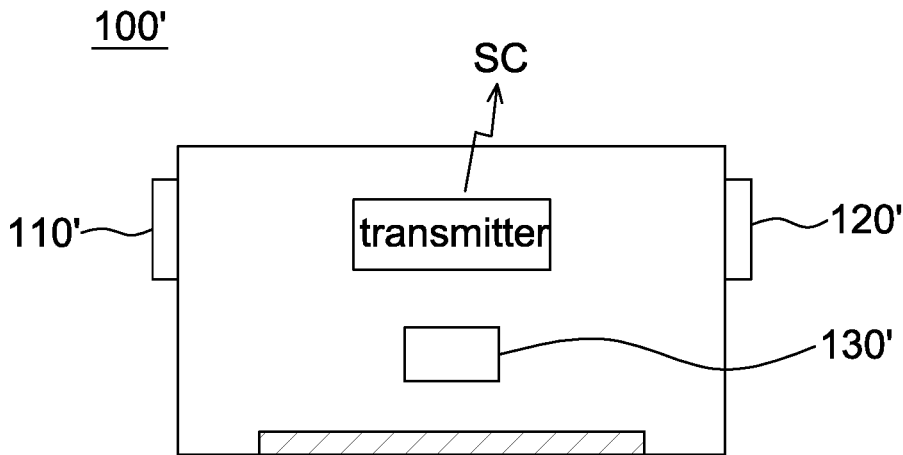

FIG. 10

CLEANING ROBOT, CLEANING ROBOT SYSTEM AND OPERATING METHOD THEREOF

SUMMARY

RELATED APPLICATIONS

[0001] The present application is a continuation application of U.S. Pat. Application Serial No. 16/386,563 filed on Apr. 17, 2019, which claims priority to China Application Number 201811056712.X, filed Sep. 11, 2018, the disclosure of which is hereby incorporated by reference herein in its entirety.

[0002] To the extent any amendments, characterizations, or other assertions previously made (in this or in any related patent applications or patents, including any parent, sibling, or child) with respect to any art, prior or otherwise, could be construed as a disclaimer of any subject matter supported by the present disclosure of this application, Applicant hereby rescinds and retracts such disclaimer. Applicant also respectfully submits that any prior art previously considered in any related patent applications or patents, including any parent, sibling, or child, may need to be re-visited.

BACKGROUND

1. Field of the Disclosure

[0003] This disclosure generally relates to a cleaning robot and, more particularly, to a cleaning robot and an operating method thereof that identify a current position thereof according to a configuration of beacon images in an image frame acquired by an image sensor and accordingly calculate a recharge path.

2. Description of the Related Art

[0004] As the cleaning robot operates in an independent closed system, it is required that a cleaning robot has to return to a charging station for recharging. To realize the function of automatic recharging when a low battery power is detected, most of the cleaning robots return to a neighborhood of the charging station at first, and then perform a fine position correction.

[0005] More specifically, a commercial product generally uses a configuration of a signal transmitting station operating in conjunction with a light emitting diode or a signal transmitting station operating in conjunction with an infrared receiver. Different directions and distances are identified according to the energy intensity of detected wireless signals. However, this type of configuration has a problem of low accuracy. Another problem of the identification method using the energy intensity of wireless signals is that a direction of the charging station is not identifiable such that the cleaning robot may not be able to return to the charging station correctly.

[0006] Accordingly, one objective of the present disclosure is to solve the problem of more accurately returning a cleaning robot to a charging station. The problem of unable to recharge due to not able to return to a charging station correctly and due to the collision with the charging station caused by the direction error in returning to the charging station is avoided.

[0007] The present disclosure provides a cleaning robot and a recharge path determining method that calculate a relative distance and angle of the cleaning robot with respect to a charging station according to relative positions of multiple beacon images in an acquired image frame to calculate a correct recharge path.

[0008] The present disclosure further provides a cleaning robot system that changes a direction of a charging station to allow a cleaning robot to return to the charging station correctly.

[0009] The present disclosure provides a cleaning robot system including a charging station and a cleaning robot. The charging station includes multiple positioning beacons, which include a first positioning beacon arranged at a first surface of the charging station and a second positioning beacon arranged at a second surface, opposite to the first surface, of the charging station. The cleaning robot includes an image sensor and a processor. The image sensor is configured to capture light generated by the multiple positioning beacons on the charging station and generate an image frame. The processor is electrically connected to the image sensor, and configured to calculate a relative angle of the cleaning robot with respect to the charging station according to beacon images of the multiple positioning beacons in the image frame. When the relative angle between the cleaning robot with respect to a front surface, which connects the first and second surfaces, of the charging station exceeds a predetermined angle, the image sensor of the cleaning robot does not capture the light generated by one of the first positioning beacon and the second positioning beacon. The first positioning beacon is protruded out from the first surface and the second positioning beacon is protruded out from the second surface to cause the light from both the first positioning beacon and the second positioning beacon to be acquired by the image sensor of the cleaning robot to form beacon images when the cleaning robot is in front of the front surface of the charging station.

[0010] The present disclosure further provides a cleaning robot including an image sensor and a processor. The image sensor is configured to capture light generated by multiple positioning beacons each having a predetermined characteristic, the multiple positioning beacons including a first positioning beacon arranged at a first surface of a charging station and a second positioning beacon arranged at a second surface, opposite to the first surface, of the charging station, and generate an image frame. The processor is electrically connected to the image sensor, and configured to calculate a relative angle of the cleaning robot with respect to the multiple positioning beacons according to beacon images of the multiple positioning beacons in the image frame. When the relative angle between the cleaning robot with respect to a surface connecting the first and second surfaces exceeds a predetermined angle, the image sensor of the cleaning robot does not capture the light generated by one of the first positioning beacon and the second positioning beacon. The first positioning beacon is protruded out from the first surface and the second positioning beacon is protruded out from the second surface to cause the light from both the first positioning beacon and the second positioning beacon to be acquired by the image sensor of the cleaning robot to form beacon images when the cleaning robot is in front of the surface connecting the first and second surfaces.

[0011] The present disclosure further provides an operating method of a cleaning robot system. The cleaning robot system includes a charging station that has multiple positioning beacons and a cleaning robot that has an image sensor and a processor. The multiple positioning beacons include a first positioning beacon arranged at a first surface of the charging station and a second positioning beacon arranged at a second surface, opposite to the first surface, of the charging station. The operating method includes the steps of: capturing, by the image sensor, light generated by the multiple positioning beacons on the charging station and generating, by the image sensor, an image frame; and calculating, by the processor, a relative position of the cleaning robot with respect to the charging station according to beacon images of the multiple positioning beacons in the image frame, wherein the first positioning beacon is protruded out from the first surface and the second positioning beacon is protruded out from the second surface to cause the light from both the first positioning beacon and the second positioning beacon to be acquired by the image sensor of the cleaning robot to form beacon images when the cleaning robot is in front of the charging station.

[0012] In the embodiments of the present disclosure, the beacon characteristic includes the light pattern, color, emission frequency, size and so on.

[0013] In the embodiments of the present disclosure, a number of positioning beacons is at least 3 to correctly calculate a relative distance and a relative angle according to a single image frame.

BRIEF DESCRIPTION OF THE DRAWINGS

[0014] Other objects, advantages, and novel features of the present disclosure will become more apparent from the following detailed description when taken in conjunction with the accompanying drawings.

[0015] FIG. 1 is a front view of a charging station of a cleaning robot system according to one embodiment of the present disclosure.

[0016] FIG. 2 is a top view of a cleaning robot system according to one embodiment of the present disclosure.

[0017] FIG. 3 is a schematic diagram of a cleaning robot located at a first relative position according to one embodiment of the present disclosure.

[0018] FIG. 4 is an image frame captured by the cleaning robot shown in FIG. 3.

[0019] FIG. 5 is another schematic diagram of a cleaning robot located at the first relative position according to one embodiment of the present disclosure.

[0020] FIG. 6 is an image frame captured by the cleaning robot shown in FIG. 5.

[0021] FIG. 7 is a schematic diagram of a cleaning robot located at a second relative position according to one embodiment of the present disclosure.

[0022] FIG. 8 is an image frame captured by the cleaning robot shown in FIG. 7.

[0023] FIG. 9 is a flow chart of a recharge path determining method of a cleaning robot system according to one embodiment of the present disclosure.

[0024] FIG. 10 is a front view of a charging station of a cleaning robot system according to another embodiment of the present disclosure.

DETAILED DESCRIPTION OF THE EMBODIMENT

[0025] It should be noted that, wherever possible, the same reference numbers will be used throughout the drawings to refer to the same or like parts.

[0026] The function of every embodiment of the present disclosure is to use an image sensor to watch a charging station, and use an algorithm to calculate a correct distance and angle based on a predetermined configuration and quantity of multiple positioning beacons on the charging station. In this way, a cleaning robot may accurately return to the charging station corresponding to a direction of the charging station. Furthermore, the direction of the charging station is automatically changeable corresponding to a moving direction of the cleaning robot to avoid error in angle while entering the charging station.

[0027] In brief, each embodiment of the present disclosure uses an image sensor to capture a charging station, and a relative distance and angle of a cleaning robot adopting the image sensor with respect to the charging station is calculated according to the captured image information. In this way, the cleaning robot can correctly return to the charging station for recharging. Some embodiments of the present disclosure are illustrated hereinafter by examples.

[0028] FIG. 1 is a front view of a charging station 100 according to one embodiment of the present disclosure; and FIG. 2 is a top view of a cleaning robot system 1000 according to one embodiment of the present disclosure. Please refer to FIGS. 1 and 2 together, the cleaning robot system 1000 of the present disclosure includes at least one charging station 100 and a cleaning robot 200, wherein the charging station 100 includes multiple positioning beacons for emitting identifiable light spectrum, e.g., FIGS. 1 and 2 showing a first infrared light source 110, a second infrared light source 120 and a third infrared light source 130 as the positioning beacons. As long as the charging station 100 is located within a field of view FOV of the image sensor 210 of the cleaning robot 200, the cleaning robot 200 may correctly return to the charging station 100 for recharging according to the method of the present disclosure.

[0029] In some embodiments, the cleaning robot system 1000 includes multiple charging stations 100, and the cleaning robot 200 returns to a charging station 100 that is located in the field of view FOV of the image sensor 210 thereof.

[0030] In this embodiment, the first infrared light source 110, the second infrared light source 120 and the third infrared light source 130 are arranged at a same surface of the charging station 100 (e.g., a surface facing a working space of the cleaning robot 200), wherein the arranged heights of the first infrared light source 110 and the second infrared light source 120 are higher than that of the third infrared light source 130, and the spatial relationship between the first infrared light source 110, the second infrared light source 120 and the third infrared light source 130 form an isosceles triangle. For example, the third infrared light source 130 is arranged at the perpendicular bisector of the charging station 100 as shown in FIG. 1, but the present disclosure is not limited thereto. It should be mentioned that the quantity and arranged height of the multiple positioning beacons of the present disclosure are only intended to illustrate but not to limit the present disclosure. Based on the concept of the present disclosure, it is possible to arrange

more than 3, e.g., 4 or 5 positioning beacons having identical or different characteristics.

[0031] In addition, the arranged height of the multiple positioning beacons includes more than two height differences according to different applications. The multiple positioning beacons may be arranged to have identical characteristics to be distinguished from ambient light, or to have different characteristics to be distinguished from one another.

[0032] In addition, the charging station **100** further includes a charging electrode base **140** as shown in FIGS. **1** and **2**, wherein when approaching or in contact with the charging electrode base **140**, the charging robot **200** is recharged. It is appreciated that the arranged position, the shape and the size of the charging electrode base **140** are arranged corresponding to the charging electrode of cleaning robot **200**. In one non-limiting embodiment, the charging electrode base **140** has at least one charging electrode as a passive light source. The charging electrode is used to reflect light generated by an illumination light source of the cleaning robot **200** to be used as at least one of the multiple positioning beacons.

[0033] The cleaning robot **200** of the present disclosure is arranged with an image sensor **210**. The image sensor **210** captures images in front (e.g., a moving direction) of the cleaning robot **200**. Accordingly, when the charging station **100** is within a field of view FOV of the image sensor **210**, the image sensor **210** captures light generated by the multiple positioning beacons on the charging station **100** and generates an image frame. For example, FIGS. **4** and **6** respectively show beacon images of the infrared light sources **110**, **120** and **130**, wherein FIGS. **4** and **6** respectively show image frames IF1 and IF2 captured by the image sensor **210** from “different angles” when the cleaning robot **200** is at “different relative positions” as shown in FIGS. **3** and **5**.

[0034] The cleaning robot **200** further includes a processor **230** electrically connected to the image sensor **210** to calculate a relative position with respect to the charging station **100** according to beacon images (e.g., I_{110} to I_{130} in FIGS. **4** and **6**) of the multiple positioning beacons in the image frame. The processor **230** drives a motor (also electrically connected to the processor **230**) of the cleaning robot **200** according to the calculated relative position to control the cleaning robot **200** to return to the charging station **100** for recharging. More specifically speaking, a charging position of the charging station **100** is at a predetermined position with respect to the multiple positioning beacons. When the cleaning robot **200** moves to the predetermined position, the electrode on the cleaning robot **200** contacts the charging electrode of the charging station **100** to start recharging.

[0035] The predetermined position includes a distance and an angle. The processor **230** firstly controls the cleaning robot **200** to move to a predetermined distance from the multiple positioning beacons, and then controls the cleaning robot **200** to continuously move, maintaining the predetermined distance, to a predetermined angle. Or, the processor **230** firstly controls the cleaning robot **200** to move to the predetermined angle with respect to the multiple positioning beacons, and then controls the cleaning robot **200** to continuously move, maintaining the predetermined angle, to the predetermined distance.

[0036] One method for calculating the relative position is the perspective-3-point (P3P) algorithm, which is a normal method of solving the perspective-n-point (PnP) pro-

blem. The algorithm is to project 3 points (e.g., corresponding to 3 positioning beacons of the present disclosure) having known relative distance in the 3D space to a 2D plane, and then respectively generate a transfer matrix between each other. By calculating the relationship between the 3 projected points having different distances therebetween in the 2D plane, it is able to derive a distance and angle in the 3D space at which these 3 points are watched. That is, the relative distance and relative angle are obtainable using the P3P algorithm.

[0037] For example in FIG. **2**, it is assumed that the first positioning beacon **110** has a position A, the second positioning beacon **120** has a position B, the third positioning beacon **130** has a position C, and the image sensor **210** has a projection center P. Meanwhile, it is also assumed that $X=|PA|$, $Y=|PB|$, $Z=|PC|$, $\alpha=\angle BPC$, $\beta=\angle APC$, $\gamma=\angle APB$, $p=2\cos\alpha$, $q=2\cos\beta$, $r=2\cos\gamma$, $a'=|AB|$, $b'=|BC|$ and $c'=|AC|$. Then, the P3P equation system is obtained as:

$$Y^2+Z^2-YZp-b^2=0$$

$$Z^2+X^2-XZq-c^2=0$$

$$X^2+Y^2-XYr-a^2=0$$

[0038] The processor **230** calculates an optimum solution of the simultaneous equations.

[0039] More specifically speaking, when the cleaning robot **200** is not right in front of the charging station **100**, as shown in FIG. **4**, the image sensor **210** captures images of the infrared light sources **110**, **120** and **130** on the charging station **100** as the charging station **100** falls into a field of view FOV of the image sensor **210** to respectively generate beacon images I_{110} to I_{130} in the image frame IF1. It should be mentioned that the image sensor **210** of the present disclosure is an infrared light sensor so as to suitable for detecting images of the infrared light sources **110**, **120** and **130**. In another non-limiting embodiment, the cleaning robot **200** further has an infrared light source as an illumination light source. The infrared light source emits light toward the multiple positioning beacons, e.g., an emission angle of the infrared light source being substantially overlapped with at least a part of the field of view FOV of the image sensor **210**. In this case, the charging station **100** is arranged with three reflective bars to replace the first infrared light source **110**, the second infrared light source **120** and the third infrared light source **130**. In this way, similar image information is obtainable. In other words, the multiple positioning beacons of the present disclosure are selected from active light sources that directly emit light or passive light sources that reflect light emitted by the illumination light source of the cleaning robot **200**.

[0040] Referring to FIGS. **3** and **4** continuously, since the image sensor **210** acquires an image frame IF1 as shown in FIG. **4**, it is able to calculate a distance $D1$ and an angle $\theta1$ of the cleaning robot **200** with respect to the charging station **100** according to sizes $A1$, $A2$, $A3$ and relative distances $d1a$, $d2a$, $d3a$ of the captured beacon images I_{110} , I_{120} , I_{130} of the infrared light sources **110**, **120** and **130**. Compared to the conventional method that uses the intensity of wireless signals to identify a distance, the present disclosure can obtain more accurate position information.

[0041] When the cleaning robot 200 moves to the position shown in FIG. 5 at which the charging station 100 is right in front of the image sensor 210, the image frame IF2 associated with the infrared light sources 110, 120 and 130 are obtained as shown in FIG. 6, which also includes beacon images I_{110} , I_{120} and I_{130} . Since the relative angle between the cleaning robot 200 and the charging station 100 is changed, the relative distances $d1$, $d2$, $d3$ of the beacon images I_{110} , I_{120} and I_{130} of the infrared light sources 110, 120 and 130 in FIG. 6 are different from the distances $d1a$, $d2a$, $d3a$ in FIG. 4. Similarly, by obtaining the image information of the infrared light sources 110, 120 and 130 as in FIG. 6, it is also able to calculate a current distance $D1$ and angle (e.g., angle=0 degree corresponding to $d1=d2$ or $d1=d2=d3$) of the cleaning robot 200 with respect to the charging station 100.

[0042] It should be mentioned that, for illustration purposes, embodiments in FIGS. 3 and 5 are different by only changing an angle of the cleaning robot 200 with respect to the charging station 100 (e.g., implemented by moving the cleaning robot 200 in transverse direction or rotating the charging station 100), and the distance $D1$ of the cleaning robot 200 with respect to the charging station 100 is not adjusted. Accordingly, compared with FIG. 4, in FIG. 6 only the relative distances and positions of the beacon images I_{110} , I_{120} and I_{130} of the infrared light sources 110, 120 and 130 are changed, but the sizes $A1$, $A2$ and $A3$ of the beacon images I_{110} , I_{120} and I_{130} of the infrared light sources 110, 120 and 130 are not changed. In actual operation, the sizes $A1$, $A2$ and $A3$ of the beacon images I_{110} , I_{120} and I_{130} of the infrared light sources 110, 120 and 130 between FIGS. 4 and 6 still have a slight difference. More specifically, when a relative distance $D1$ between the charging station 100 and the cleaning robot 200 is farther, the sizes $A1$, $A2$ and $A3$ of the beacon images I_{110} , I_{120} and I_{130} of the infrared light sources 110, 120 and 130 between FIGS. 4 and 6 only have a tiny difference, and details of this physical mechanism are not illustrated herein.

[0043] In addition to using the above P3P algorithm to calculate the relative position between the charging station 100 and the cleaning robot 200, other methods can be used. In another aspect, a look up table regarding the relationship between a ratio of image distances between the beacon images I_{110} , I_{120} and I_{130} (e.g., $d1a$, $d2a$, $d3a$ in FIG. 4) and relative angles $\theta1$ is previously stored in the memory. In this way, when the processor 230 calculates the image distances, it is able to obtain a relative angle $\theta1$ according to the look up table accordingly.

[0044] In addition, referring to FIGS. 3 and 7 that show different relative distances (e.g., $D1 \neq D2$) between the charging station 100 and the cleaning robot 200, and the image sensor 210 respectively captures the image frames IF1 and IF3 associated with the infrared light sources 110, 120 and 130 as shown in FIGS. 4 and 8. It is seen from IF1 and IF3 that at the same angle $\theta1$, compared with the sizes $A1$, $A2$, $A3$ of the beacon images I_{110} , I_{120} and I_{130} of the infrared light sources 110, 120 and 130 in FIG. 4, the sizes $A1'$, $A2'$, $A3'$ of the beacon images I_{110} , I_{120} and I_{130} of the infrared light sources 110, 120 and 130 in FIG. 8 are smaller since the relative distance between the charging station 100 and the cleaning robot 200 is farther (e.g., $D2$ is larger). In other words, by processing the image in this way, it is able to obtain the current distance $D1$ or $D2$.

[0045] More specifically, in addition to calculating the relative position between the charging station 100 and the

cleaning robot 200 using the P3P algorithm, it is able to calculate the relative distance $D1$ and $D2$ using other methods such as according to the sizes and distances of the beacon images I_{110} , I_{120} and I_{130} or according to an area of a triangle formed by the beacon images I_{110} , I_{120} and I_{130} .

[0046] The method of implementing the recharging of the cleaning robot 200 is illustrated in the flow chart of FIG. 9. When the image sensor 210 on the cleaning robot 200 detects positions of different positioning beacons, this information is sent to the processor (e.g., central processing unit, microcontroller unit or application specific integrated circuit) to be processed. Then, the processor 230 uses the embedded algorithm (as mentioned above) to calculate the relative distance and angle between the charging station 100 and cleaning robot 200 using position information of the positioning beacons. The processor 230 also calculates a suitable control signal according to the calculated relative distance and angle, and uses this control signal to control a motor for driving wheels thereby achieving the purpose of returning the robot for recharging.

[0047] For example, the recharge path determining method for a cleaning robot system in FIG. 9 includes the steps of: capturing, by an image sensor, light generated by multiple positioning beacons on a charging station and generating an image frame (Step S910); calculating, by a processor, a relative position with respect to the charging station according to beacon images of the multiple positioning beacons in the image frame (Step S930); and controlling, by the processor, the cleaning robot according to the relative position to return to the charging station for recharging (Step S950), wherein details of the determining method has been illustrated above and thus details thereof are not repeated again.

[0048] As mentioned above, the processor 230 calculates the relative position between the charging station 100 and the cleaning robot 200 according to the PnP algorithm (e.g., P referred to a number of beacons), look up table, sizes of beacon images or distances between beacon images, and controls the cleaning robot 200 to return to the charging station 100 for recharging according to the calculated relative position. In one non-limiting embodiment, the processor 230 firstly controls the cleaning robot 200 to move (using the motor to roll wheels) to a predetermined distance relative to the multiple positioning beacons, and then controls the cleaning robot 200 to continuously move, at the predetermined distance, to a predetermined angle, or vice versa, or to change the relative distance and relative angle together till the cleaning robot 200 successively returns to the charging station 100.

[0049] As mentioned above, the multiple positioning beacons are active or passive light sources. When the multiple positioning beacons are passive light sources, the cleaning robot 200 further includes an illumination light source used to emit light for illuminating the passive light sources. The processor 230 controls the illumination light source to emit light corresponding to the image capturing of the image sensor 210.

[0050] As mentioned above, the multiple positioning beacons have different characteristics. The processor 230 distinguishes different beacons according to the different characteristics so as to identify whether the cleaning robot 200 is at a left or right side of the charging station 100 in calculating the relative position.

[0051] As mentioned above, the charging station **100** is rotatable such that when identifying that the cleaning robot **200** is not at right front of the charging station **100**, the processor **230** sends a control signal S_c to the charging station **100** to rotate the charging station **100** to directly face the cleaning robot **200**. In this case, the processor **230** only needs to control the cleaning robot **200** to move forward the charging station **100**, and the relative angle is adjusted by changing a facing direction of the charging station **100**.

[0052] In addition, when the processor **230** identifies that the image frame captured by the image sensor **210** does not contain any beacon image, the processor **230** further controls the field of view of the image sensor **210**, e.g., rotating the cleaning robot **200** or rotating a platform on which the image sensor **210** is arranged, to search a direction of the charging station **100**.

[0053] Please refer to FIG. **10**, it is a front view of a charging station **100'** according to another embodiment of the present disclosure. The charging station **100'** of this embodiment also includes multiple positioning beacons, e.g., **110'**, **120'** and **130'**. A first positioning beacon **110'** is located at a first surface of the charging station **100'**, e.g., left surface. A second positioning beacon **120'** is located at a second surface of the charging station **100'**, e.g., right surface. A third positioning beacon **130'** is located at a third surface of the charging station **100'**, e.g., front surface. In this embodiment, the first positioning beacon **110'** and the second positioning beacon **120'** preferably have different characteristics, e.g., different patterns, colors, emission frequencies, sizes and so on, for being distinguished by the processor **230**.

[0054] The multiple positioning beacons in the above mentioned embodiments are arranged at the same surface, but the first positioning beacon **110'** and the second positioning beacon **120'** in this embodiment are arranged at two different surfaces opposite to each other. In this way, when the cleaning robot **200** is at a left side of the charging station **100'** and the relative angle exceeds a specific angle, the image sensor **210** is not able to capture an image of the second positioning beacon **120'**, and since the processor **230** is previously arranged to know the individual characteristics of the first positioning beacon **110'** and the second positioning beacon **120'**, the cleaning robot **200** changes its own position or sends a control signal S_c to the charging station **100'** to change a direction thereof. Similarly, when the cleaning robot **200** is at a right side of the charging station **100'** and the relative angle exceeds a specific angle, the image sensor **210** is not able to capture an image of the second positioning beacon **110'**.

[0055] In this embodiment, the processor **230** further identifies whether a number of the beacon images (e.g., I_{110} , I_{120} and I_{130} in FIGS. **4**, **6** and **8**) is smaller than a predetermined number (e.g., 3 in this embodiment). When the number of beacon images is smaller than the predetermined number, the relative angle of the cleaning robot **200** with respect to the charging station **100** is changed, e.g., by changing a position of the cleaning robot **200** and/or rotating the charging station **100**, to allow the image sensor **210** to be able to acquire all beacon images.

[0056] In one non-limiting embodiment, the cleaning robot **200** includes a first motor for controlling the cleaning robot **200** to move forward and includes a second motor for controlling the cleaning robot **200** to rotate. When identifying that the cleaning robot **200** is at one side of the charging

station **100'**, the processor **230** firstly controls the cleaning robot **200** to move toward an opposite side of the charging station **100'** to allow the image sensor **210** to be able to acquire beacon images of all the first positioning beacon **110'**, the second positioning beacon **120'** and the third positioning beacon **130'**. Then, the processor **230** calculates the relative position of the cleaning robot **200** with respect to the charging station **100'** according to the above mentioned method. Or, the cleaning robot **200** includes a transmitter for sending a control signal S_c to the charging station **100'** to change an emission direction of the multiple positioning beacons (i.e. rotating the charging station **100'**) to allow the image sensor **210** to be able to acquire beacon images of all the first positioning beacon **110'**, the second positioning beacon **120'** and the third positioning beacon **130'**. Then, the processor **230** calculates the relative position of the cleaning robot **200** with respect to the charging station **100'** according to the above mentioned method.

[0057] In addition, when identifying that the image frame captured by the image sensor **210** does not contain any beacon image, the processor **230** controls the second motor to cause the cleaning robot **200** to perform an in situ rotation at its current position or controls a platform on which the image sensor **210** is carried to rotate so as to acquire light emitted by the multiple positioning beacons.

[0058] It should be mentioned that although the multiple positioning beacons in the above embodiments are shown as a rectangle as an example, the present disclosure is not limited thereto. In other embodiments, the multiple positioning beacons are selected from other shapes, e.g., circular shape, diamond shape and so on, as long as that shape is identifiable by the processor **230**.

[0059] As mentioned above, the conventional cleaning robot can only determine the distance according to the energy intensity of wireless signals, and has the problem of unable to correctly return to the charging station. Accordingly, the present disclosure provides a cleaning robot system (e.g., FIGS. **2-8** and **10**) and a recharge path determining method thereof (e.g., FIG. **9**) that identify a relative position of a cleaning robot with respect to a charging station according to images captured by an image sensor to accordingly determine a recharge path. For example, the relative distance is controlled to reach a predetermined distance at first and then a relative angle is controlled to reach a predetermined angle, or vice versa, to cause the cleaning robot to return to the recharge station correctly.

[0060] Although the disclosure has been explained in relation to its preferred embodiment, it is not used to limit the disclosure. It is to be understood that many other possible modifications and variations can be made by those skilled in the art without departing from the spirit and scope of the disclosure as hereinafter claimed.

What is claimed is:

1. A cleaning robot system, comprising:
 - a charging station, comprising multiple positioning beacons, the multiple positioning beacons including a first positioning beacon arranged at a first surface of the charging station and a second positioning beacon arranged at a second surface, opposite to the first surface, of the charging station; and
 - a cleaning robot, comprising:

- an image sensor, configured to capture light generated by the multiple positioning beacons on the charging station and generate an image frame; and
- a processor, electrically connected to the image sensor, and configured to calculate a relative angle of the cleaning robot with respect to the charging station according to beacon images of the multiple positioning beacons in the image frame,
- wherein when the relative angle between the cleaning robot with respect to a front surface, which connects the first and second surfaces, of the charging station exceeds a predetermined angle, the image sensor of the cleaning robot does not capture the light generated by one of the first positioning beacon and the second positioning beacon, and
- the first positioning beacon is protruded out from the first surface and the second positioning beacon is protruded out from the second surface to cause the light from both the first positioning beacon and the second positioning beacon to be acquired by the image sensor of the cleaning robot to form beacon images when the cleaning robot is in front of the front surface of the charging station.
2. The cleaning robot system as claimed in claim 1, wherein the multiple positioning beacons are multiple active light sources.
3. The cleaning robot system as claimed in claim 1, wherein wherein the multiple positioning beacons are multiple passive light sources, the cleaning robot further comprises an illumination light source, and the charging station further comprises a charging electrode configured to reflect light generated by the illumination light source as one of the multiple passive light sources.
4. The cleaning robot system as claimed in claim 1, wherein the multiple positioning beacons further include a third position beacon located at the front surface, and when the cleaning robot is in front of the front surface of the charging station, beacon images of the first positioning beacon, the second positioning beacon and the third position beacon form a triangle shape in the image frame .
5. The cleaning robot system as claimed in claim 4, wherein the processor is further configured to determine the relative angle according to distances between the beacon images of the first positioning beacon, the second positioning beacon and the third position beacon from a predetermined look up table.
6. The cleaning robot system as claimed in claim 1, wherein the multiple positioning beacons have identical or different characteristics.
7. The cleaning robot system as claimed in claim 1, wherein the multiple positioning beacons are arranged at at least two different heights.
8. The cleaning robot system as claimed in claim 1, wherein the charging station is rotatable.
9. A cleaning robot, comprising:
an image sensor, configured to capture light generated by multiple positioning beacons each having a predetermined characteristic, the multiple positioning beacons including a first positioning beacon arranged at a first surface of a charging station and a second positioning beacon arranged at a second surface, opposite to the first surface, of the charging station, and generate an image frame; and
- a processor, electrically connected to the image sensor, and configured to calculate a relative angle of the cleaning robot with respect to the multiple positioning beacons according to beacon images of the multiple positioning beacons in the image frame,
- wherein when the relative angle between the cleaning robot with respect to a surface connecting the first and second surfaces exceeds a predetermined angle, the image sensor of the cleaning robot does not capture the light generated by one of the first positioning beacon and the second positioning beacon, and
- the first positioning beacon is protruded out from the first surface and the second positioning beacon is protruded out from the second surface to cause the light from both the first positioning beacon and the second positioning beacon to be acquired by the image sensor of the cleaning robot to form beacon images when the cleaning robot is in front of the surface connecting the first and second surfaces.
10. The cleaning robot as claimed in claim 9, further comprising:
a first motor, configured to control the cleaning robot to move forward; and
a second motor, configured to control the cleaning robot to rotate.
11. The cleaning robot as claimed in claim 10, wherein the processor is further configured to control the second motor to cause the cleaning robot to perform an in situ rotation when the image frame does not contain any beacon image.
12. The cleaning robot as claimed in claim 9, further comprising an illumination light source configured to emit light toward the multiple positioning beacons.
13. The cleaning robot as claimed in claim 9, further comprising a transmitter configured to transmit a control signal to change an emission direction of the multiple positioning beacons.
14. The cleaning robot as claimed in claim 9, wherein the processor is further configured to control the cleaning robot to move to a predetermined distance from the multiple positioning beacons at first, and then control the cleaning robot to continuously move, at the predetermined distance, to a predetermined angle with respect to the multiple positioning beacons, or control the cleaning robot to move to the predetermined angle with respect to the multiple positioning beacons at first, and then control the cleaning robot to continuously move, at the predetermined angle, to the predetermined distance from the multiple positioning beacons.
15. An operating method of a cleaning robot system, the cleaning robot system comprising a charging station that has multiple positioning beacons and a cleaning robot that has an image sensor and a processor, the multiple positioning beacons including a first positioning beacon arranged at a first surface of the charging station and a second positioning beacon arranged at a second surface, opposite to the first surface, of the charging station, the operating method comprising:
capturing, by the image sensor, light generated by the multiple positioning beacons on the charging station and generating, by the image sensor, an image frame; and
calculating, by the processor, a relative position of the cleaning robot with respect to the charging station according to beacon images of the multiple positioning beacons in the image frame,

wherein the first positioning beacon is protruded out from the first surface and the second positioning beacon is protruded out from the second surface to cause the light from both the first positioning beacon and the second positioning beacon to be acquired by the image sensor of the cleaning robot to form beacon images when the cleaning robot is in front of the charging station.

16. The operating method as claimed in claim **15**, wherein the cleaning robot further comprises an illumination light source, and the operating method further comprises:

controlling the illumination light source to emit light corresponding to the light capturing of the image sensor.

17. The operating method as claimed in claim **15**, further comprising:

distinguishing, by the processor, different positioning beacons according to different characteristics of the multiple positioning beacons.

18. The operating method as claimed in claim **15**, further comprising:

transmitting, by the cleaning robot, a control signal to the charging station to rotate the charging station.

19. The operating method as claimed in claim **15**, further comprising:

controlling, by the processor, a field of view of the image sensor when the image frame does not contain any beacon image.

* * * * *