



(19) **United States**

(12) **Patent Application Publication**
PARK et al.

(10) **Pub. No.: US 2015/0157289 A1**

(43) **Pub. Date: Jun. 11, 2015**

(54) **METHOD AND APPARATUS FOR SETTING OPERATING CONDITION OF DETECTOR REGISTERED TO IMAGING SYSTEM BASED ON DETECTOR INFORMATION PRE-STORED IN THE DETECTOR**

Publication Classification

- (51) **Int. Cl.**
A61B 6/00 (2006.01)
A61B 8/00 (2006.01)
A61B 6/03 (2006.01)
A61B 5/055 (2006.01)
- (52) **U.S. Cl.**
 CPC . *A61B 6/54* (2013.01); *A61B 6/585* (2013.01);
A61B 6/563 (2013.01); *A61B 5/055* (2013.01);
A61B 8/54 (2013.01); *A61B 6/032* (2013.01);
A61B 8/565 (2013.01); *A61B 8/58* (2013.01)

(71) Applicant: **SAMSUNG ELECTRONICS CO., LTD.**, Suwon-si (KR)

(72) Inventors: **Jong-seo PARK**, Yongin-si (KR);
Woo-sup HAN, Yongin-si (KR)

(73) Assignee: **SAMSUNG ELECTRONICS CO., LTD.**, Suwon-si (KR)

(57) **ABSTRACT**

A method of setting operating conditions of a detector in an imaging system includes searching for a detector that is not registered in the imaging system; acquiring detector profile information from the searched detector; registering the detector based on the detector profile information; allocating a predetermined marker to the registered detector to represent activation or non-activation thereof; transmitting control information including the allocated predetermined marker to the detector; receiving detector correction information from the detector; and setting operating conditions of the detector based on the received detector correction information.

(21) Appl. No.: **14/540,132**

(22) Filed: **Nov. 13, 2014**

(30) **Foreign Application Priority Data**

Dec. 5, 2013 (KR) 10-2013-0150828

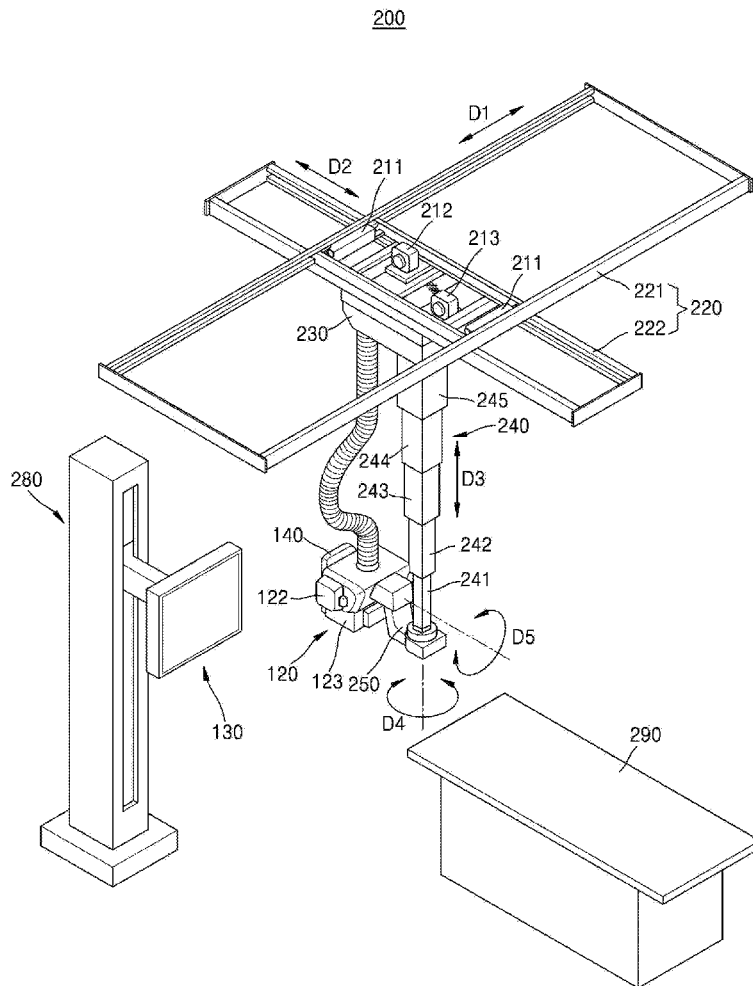

FIG. 1

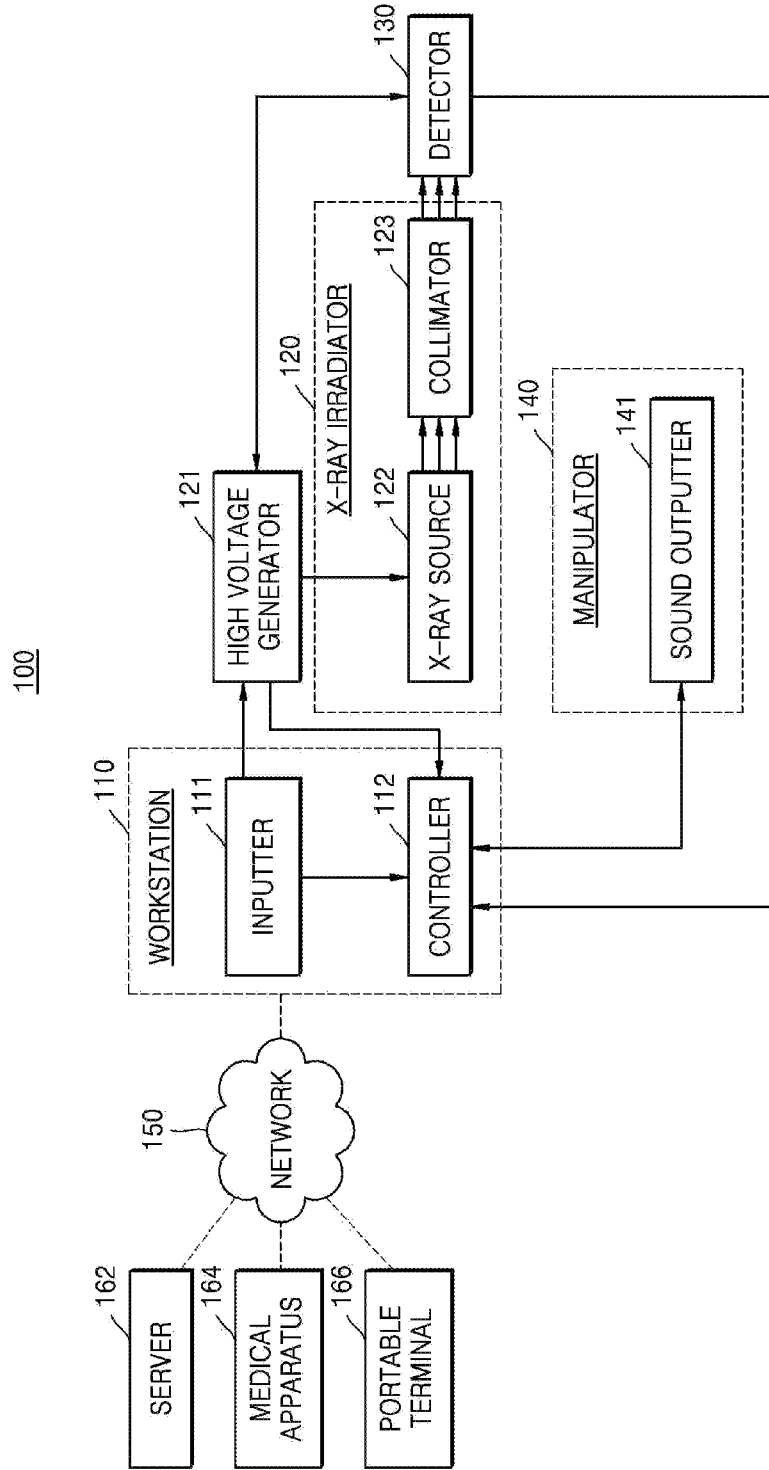
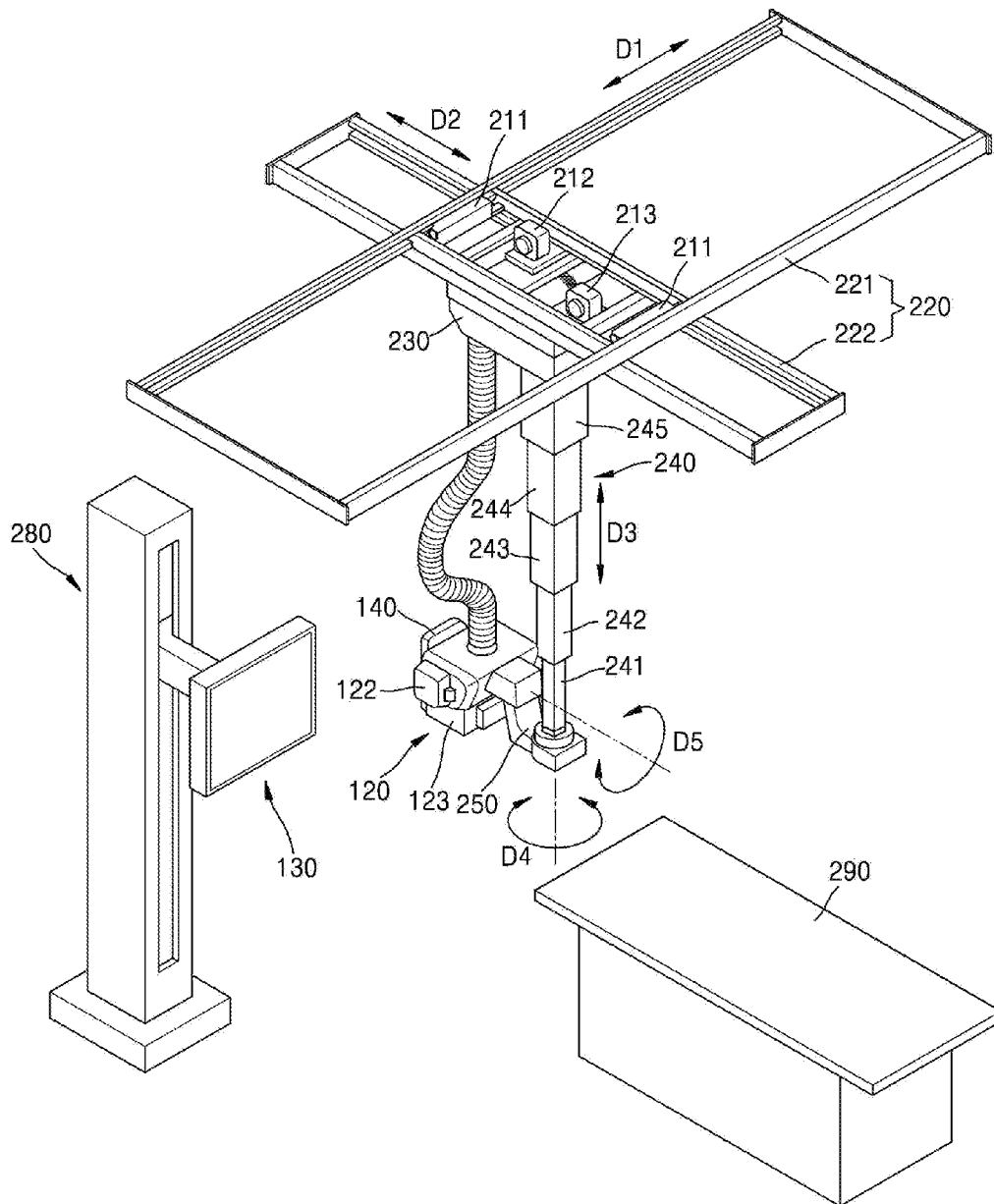
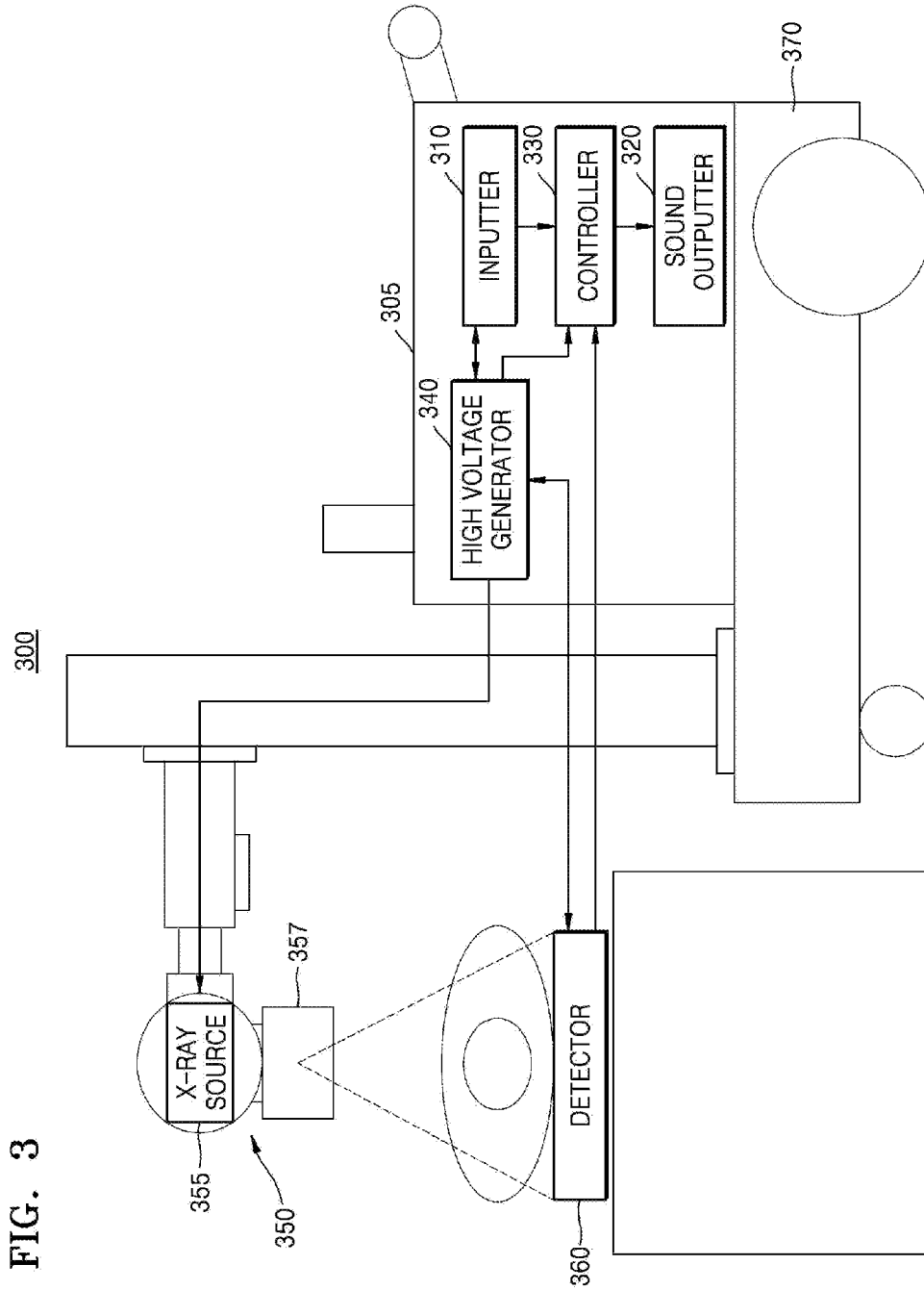

FIG. 2

200





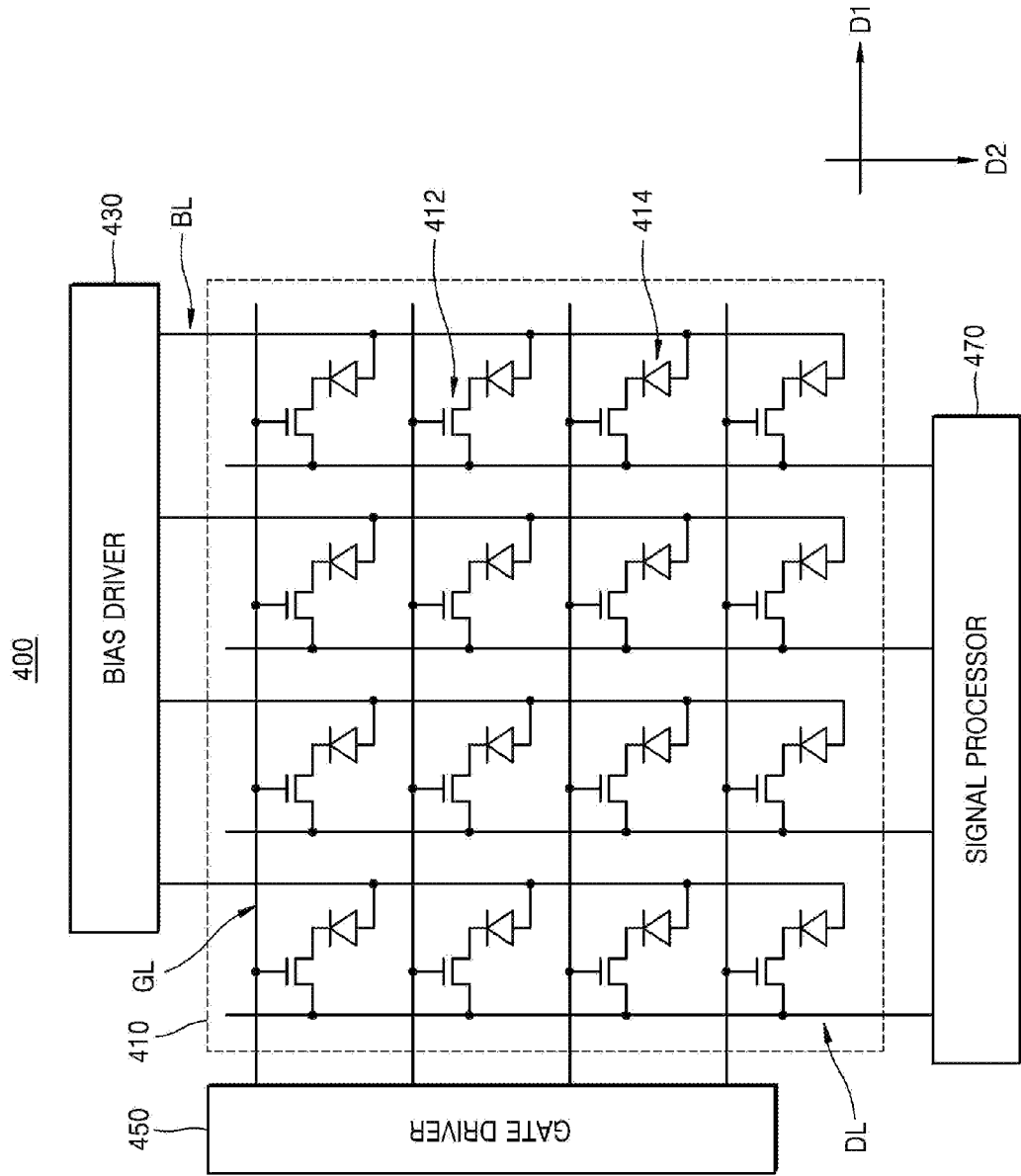

FIG. 4

FIG. 5

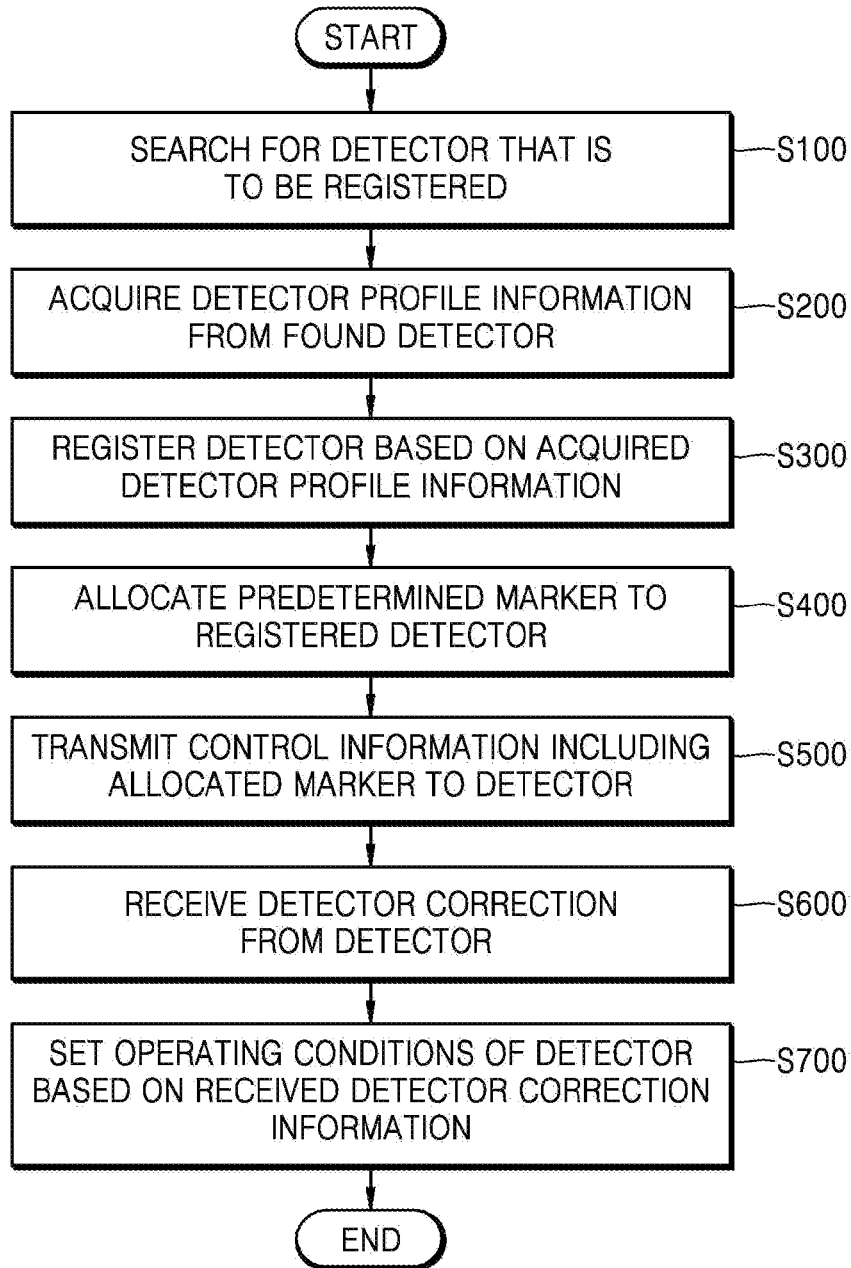

FIG. 6

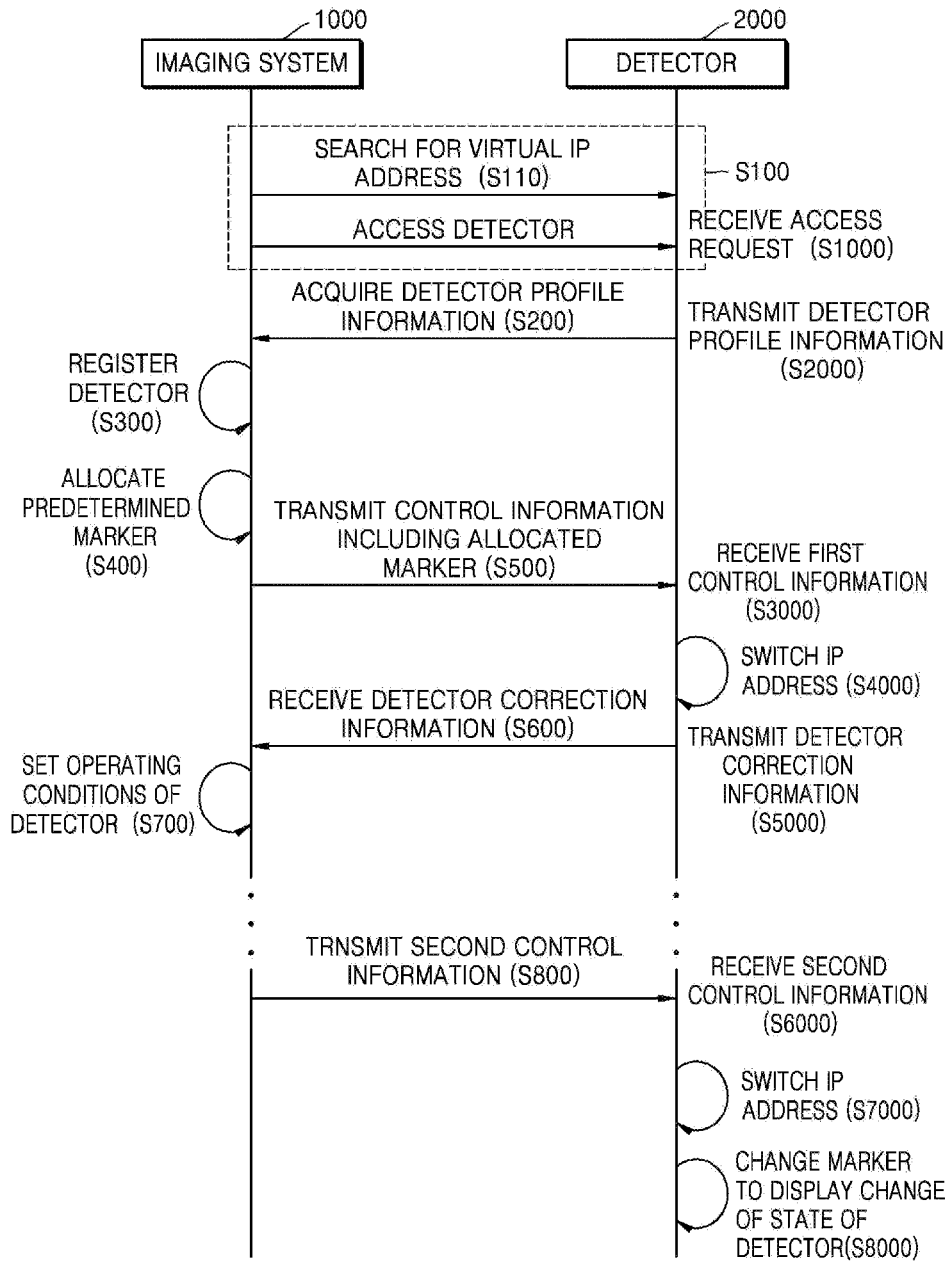

FIG. 7A

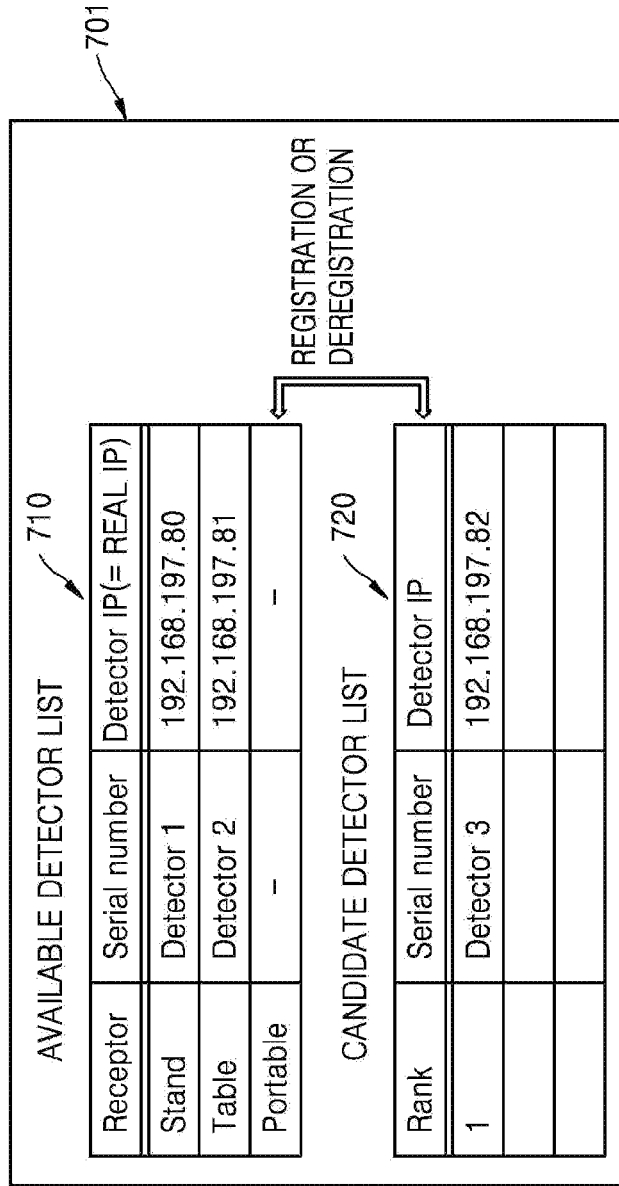

FIG. 7B

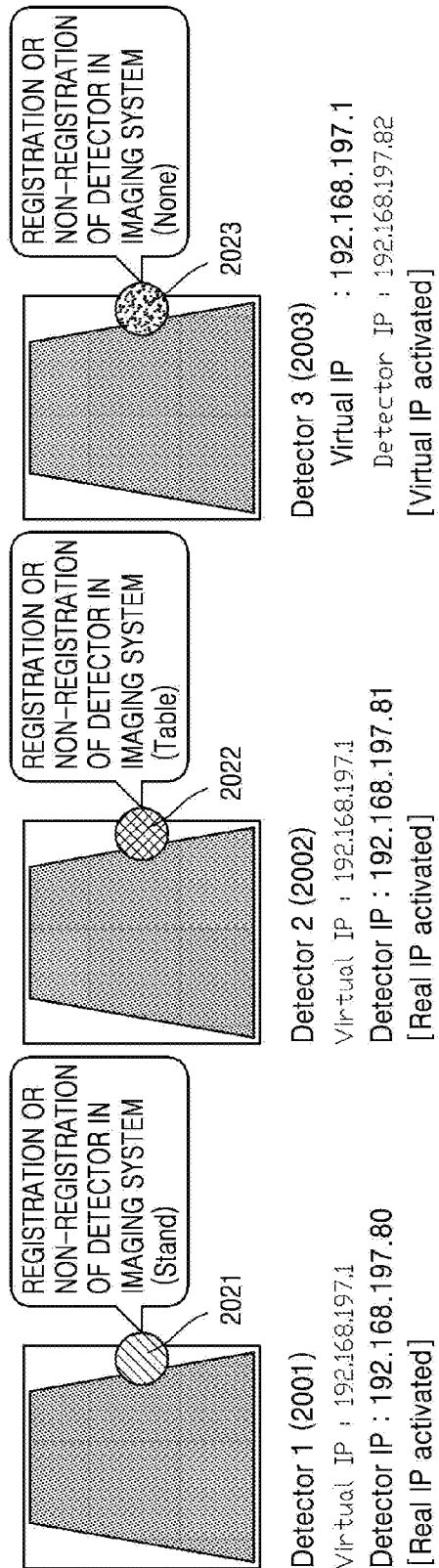

FIG. 8

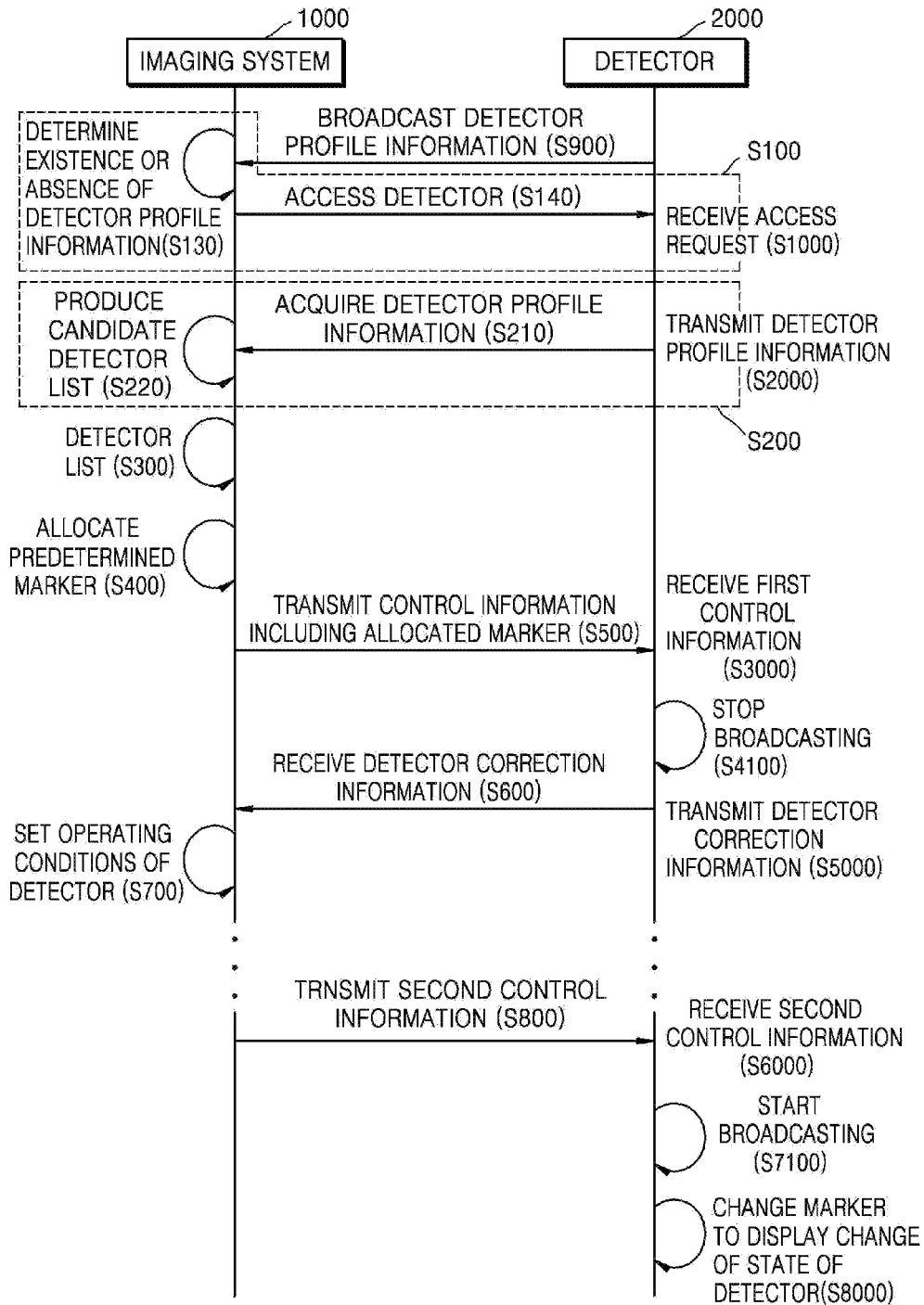

FIG. 9

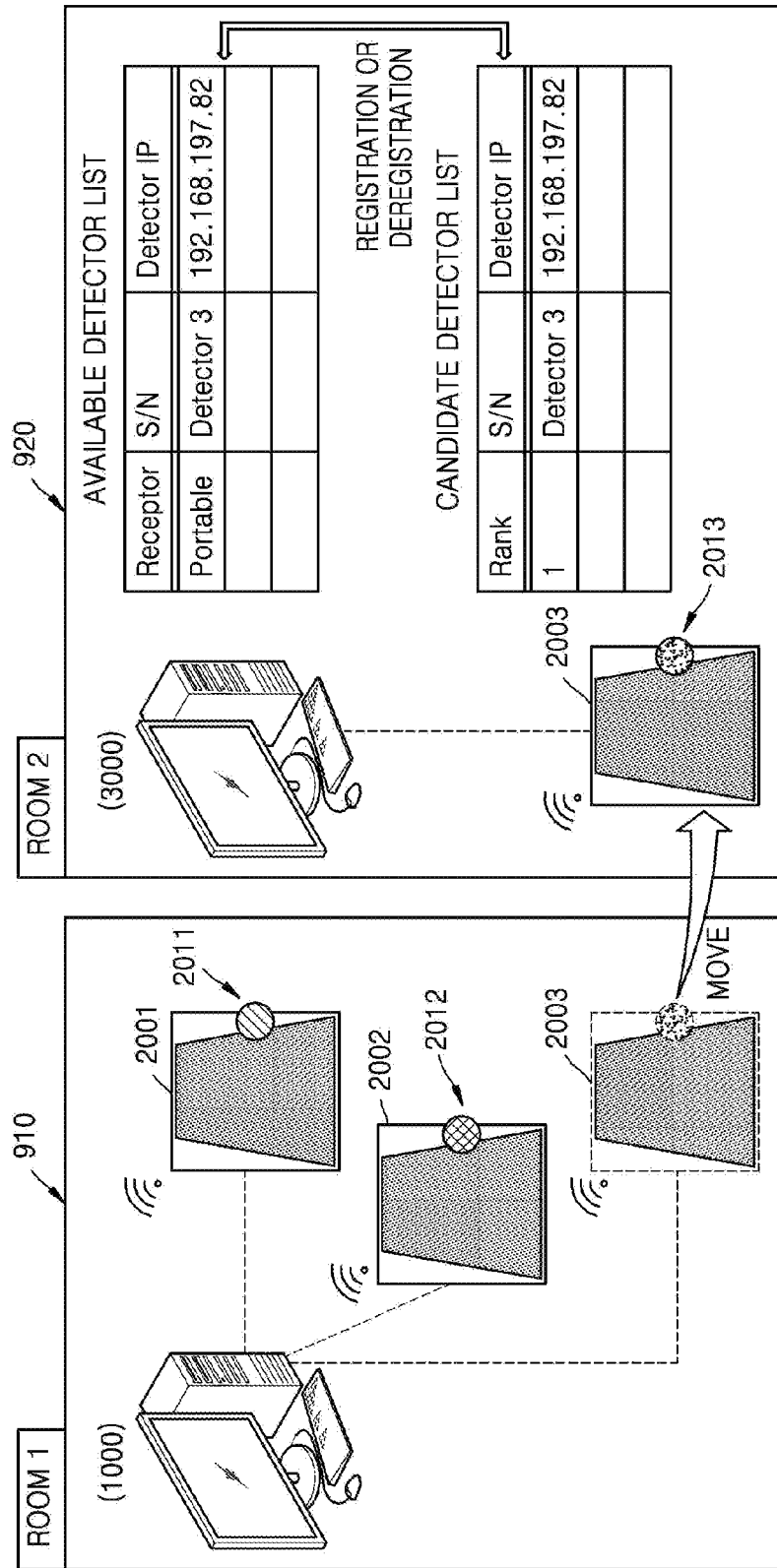

FIG. 10

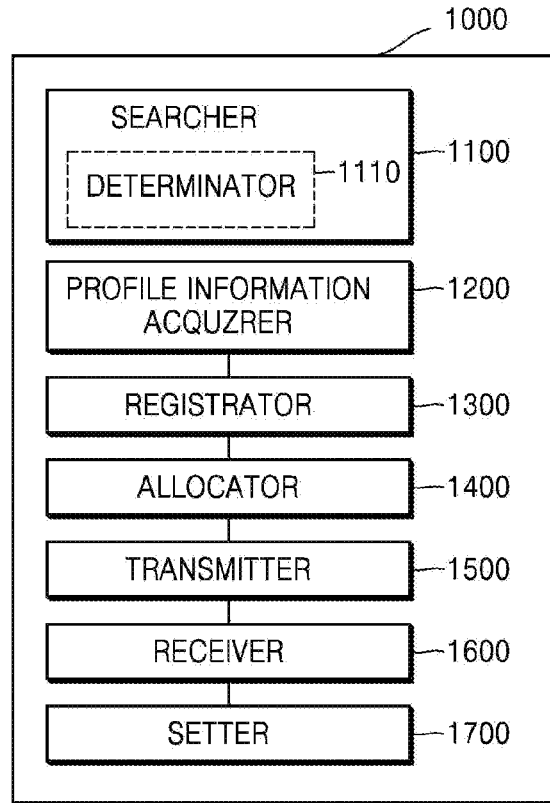

FIG. 11

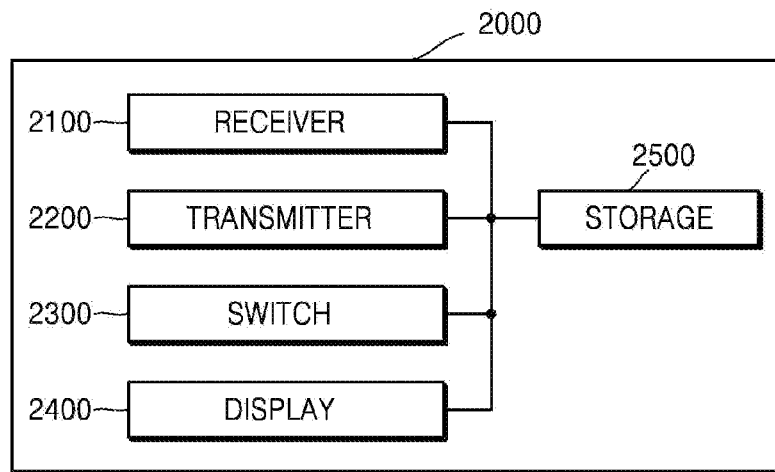
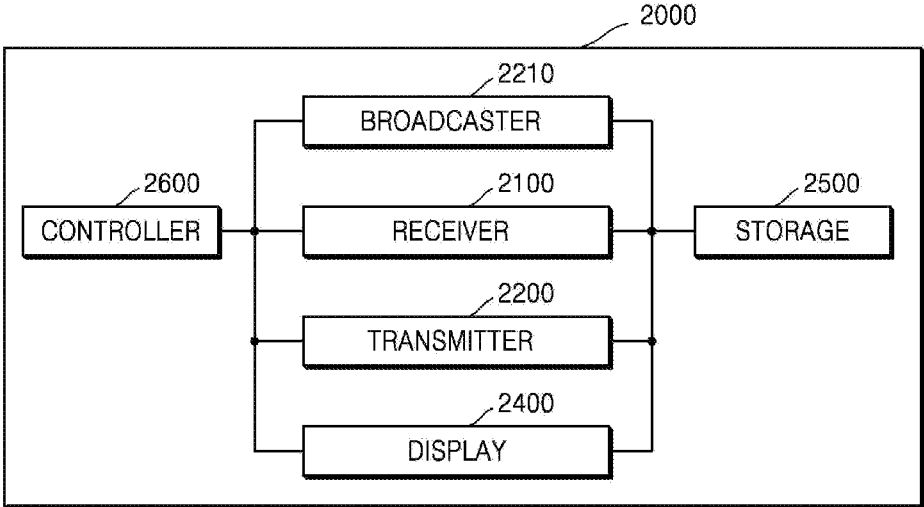

FIG. 12



**METHOD AND APPARATUS FOR SETTING
OPERATING CONDITION OF DETECTOR
REGISTERED TO IMAGING SYSTEM BASED
ON DETECTOR INFORMATION
PRE-STORED IN THE DETECTOR**

CROSS-REFERENCE TO RELATED
APPLICATION(S)

[0001] This application claims priority from Korean Patent Application No. 10-2013-0150828, filed on Dec. 5, 2013, in the Korean Intellectual Property Office, the disclosure of which is incorporated herein in its entirety by reference.

BACKGROUND

[0002] 1. Field

[0003] Apparatuses and methods consistent with exemplary embodiments relate to a method and an apparatus for setting operating conditions of a detector registered in an imaging system, and more particularly, to a method and an apparatus for setting operating conditions of a detector registered in an imaging system based on detector information pre-stored in the detector.

[0004] 2. Description of the Related Art

[0005] In general, X-rays, which are electromagnetic waves having a wavelength of about 0.01 to about 100 Å, can pass through an object. Thus, the X-rays may be commonly used in a wide range of applications, such as medical equipment that captures images of the inside of a living body and non-destructive testing equipment for industrial use.

[0006] X-ray imaging apparatuses using X-rays allow X-rays emitted by an X-ray tube (or X-ray source) to pass through an object, and detect a difference between intensities of the passed X-rays by using an X-ray detector to identify an internal structure of the object. X-ray imaging apparatuses may easily identify the internal structure of an object by using a principle that a transmission coefficient of X-rays varies depending on a density of the object and an atomic number of an atom included in the object. As the wavelength of an X-ray becomes shorter, the transmission coefficient of X-rays increases, and a picture on a screen becomes clearer.

[0007] An X-ray imaging apparatus generally includes an X-ray source, an X-ray detector, and an image processor. The X-ray source irradiates an X-ray to a target under predetermined X-ray irradiation conditions, and the X-ray detector acquires image data based on an X-ray passed through the object and transmits the image data to the image processor. The image processor may process the image data to provide an image of the object to a display included in the X-ray imaging apparatus.

[0008] In other words, when the X-ray emitted from the X-ray source passes through the object, a scintillator included in the X-ray imaging apparatus may change the passed X-ray to visible light depending on a density of the object, and a photodiode included in the X-ray imaging apparatus may change the visible light to an electrical signal. The X-ray imaging apparatus may express a digital image of the object through which the X-ray passes, by using the electrical signal.

SUMMARY

[0009] Exemplary embodiments address at least the above problems and/or disadvantages and other disadvantages not described above. Also, exemplary embodiments are not

required to overcome the disadvantages described above, and an exemplary embodiment may not overcome any of the problems described above.

[0010] One or more exemplary embodiments include a method and an apparatus for setting operation conditions of a detector registered in an imaging system based on detector information pre-stored in the detector.

[0011] According to an aspect of an exemplary embodiment, provided is a method of setting operating conditions of a detector in an imaging system including: searching for a detector that is not registered in the imaging system; acquiring detector profile information from the searched detector; registering the detector based on the detector profile information; allocating a predetermined marker to the registered detector to represent activation or non-activation thereof; transmitting control information including the allocated predetermined marker to the detector; receiving detector correction information from the detector; and setting operating conditions of the detector based on the received detector correction information.

[0012] The searching may include searching for a virtual Internet Protocol (IP) address of the detector that is not registered in the imaging system; and accessing the detector by using the searched virtual IP address.

[0013] The detector profile information may include at least one from among a real IP address, a type, and a serial number of the detector. The registering may include storing the detector profile information to an available detector list of the imaging system.

[0014] The predetermined marker may include at least one from among a character, a number, a symbol, a color, and an image.

[0015] The receiving may include receiving the detector correction information from the detector via an access to an activated real IP address of the detector. The setting may include setting imaging conditions for performing imaging using the detector based on the detector correction information. The detector correction information may include at least one from among detector step difference correction information indicating an amount of step difference correction of the detector for performing imaging and defective pixel compensation information indicating a range of defective pixel compensation of the detector for performing imaging.

[0016] The searching may include determining whether detector profile information is broadcast on a network to which the imaging system is connected; and accessing an unregistered detector corresponding to the detector profile information that is being broadcast on the network.

[0017] The acquiring may include receiving the broadcast detector profile information from the unregistered detector; and storing the detector profile information in a candidate detector list.

[0018] The detector profile information may include at least one from among a real IP address, a type, and a serial number of the unregistered detector.

[0019] The registering may include storing the detector profile information on the candidate detector list to an available detector list of the imaging system.

[0020] The receiving may include receiving detector correction information from the detector having the detector profile information stored in the available detector list.

[0021] The setting may include setting imaging conditions for performing imaging using the detector, based on the detector correction information received from the detector.

[0022] The detector correction information may include at least one from among detector step difference correction information indicating an amount of step difference correction of the detector for performing imaging and defective pixel compensation information indicating a range of defective pixel compensation of the detector for performing imaging.

[0023] According to an aspect of another exemplary embodiment, provided is a method of transmitting detector correction information of a detector to an imaging system including: receiving, from the imaging system, a request to access the detector via a virtual IP address of the detector; transmitting detector profile information of the detector to the imaging system in response to the request; receiving, from the imaging system, first control information including an allocated predetermined marker; switching the virtual IP address of the detector based on the first control information; and transmitting the detector correction information to the imaging system.

[0024] The switching may include deactivating the virtual IP address of the detector and activating the real IP address of the detector; and displaying a change of a state of the detector by using the allocated predetermined marker.

[0025] The method may further include receiving second control information from the imaging system; deactivating the real IP address of the detector and activating the virtual IP address of the detector based on the second control information; and displaying a change of the state of the detector by using the allocated predetermined marker.

[0026] According to an aspect of an exemplary embodiment, provided is a method of transmitting detector correction information of a detector to an imaging system, the method including: broadcasting detector profile information to a network to which the imaging system is connected; receiving, from the imaging system, first control information including an allocated predetermined marker; and stopping the broadcasting and transmitting, from the detector, the detector correction information to the imaging system based on the first control information.

[0027] The stopping may include displaying a change of a state of the detector by using the allocated predetermined marker.

[0028] The method may further include receiving second control information from the imaging system; starting broadcasting of the detector profile information to the network based on the second control information; and displaying a change of the state of the detector by using the allocated predetermined marker.

[0029] According to an aspect of an exemplary embodiment, provided is an imaging system for setting operating conditions of a detector, the imaging system including: a searcher configured to search for a detector that is not registered in the imaging system; a detector information acquirer configured to acquire detector profile information about the searched detector; a registrator configured to register the detector based on the detector profile information; an allocator configured to allocate a predetermined marker to the detector to represent activation or non-activation thereof; a transmitter configured to transmit control information including the allocated predetermined marker to the detector; a receiver configured to receive detector correction information from the detector; and a setter configured to set operating conditions of the detector based on the received detector correction information.

[0030] The searcher may search for a virtual IP address of the detector that is not registered in the imaging system and may access the detector by using the searched virtual IP address.

[0031] The registrator may store the detector profile information to an available detector list of the imaging system.

[0032] The receiver may receive the detector correction information from the detector by accessing an activated real IP address of the detector. The setter may set imaging conditions for performing imaging using the detector based on the detector correction information. The detector correction information may include at least one from among detector step difference correction information indicating an amount of step difference correction of the detector for performing imaging and defective pixel compensation information indicating a range of defective pixel compensation of the detector for performing imaging.

[0033] The searcher may further include a determinator configured to determine whether detector profile information is broadcast on a network to which the imaging system is connected. The searcher may access an unregistered detector corresponding to the detector profile information being broadcast on the network.

[0034] The profile information acquirer may receive the broadcast detector profile information from the unregistered detector and store the detector profile information in a candidate detector list.

[0035] The detector profile information may include at least one from among a real IP address, a type, and a serial number of the unregistered detector.

[0036] The registrator may store the detector profile information on the candidate detector list to an available detector list of the imaging system.

[0037] The receiver may receive detector correction information from the detector having the detector profile information stored in the available detector list. The setter may set imaging conditions for performing imaging using the detector based on the detector correction information received from the detector. The detector correction information may include at least one from among detector step difference correction information indicating an amount of step difference correction of the detector for performing imaging and defective pixel compensation information indicating a range of defective pixel compensation of the detector for performing imaging.

[0038] According to an aspect of an exemplary embodiment, provided is a detector for transmitting detector correction information to an imaging system, the detector including: a receiver configured to receive a request to access the detector via a virtual IP address of the detector; a transmitter configured to transmit detector profile information of the detector to the imaging system in response to the request, wherein the imaging system registers the detector based on the detector profile information and transmits first control information including an allocated predetermined marker to the detector; a switch configured to switch the virtual IP address of the detector based on the first control information; and the transmitter configured to transmit the detector correction information to the imaging system.

[0039] The detector profile information may include at least one from among a real IP address, a type, and a serial number of the detector. The predetermined marker may include at least one from among a character, a number, a symbol, a color, and an image. The detector correction infor-

mation may include at least one from among detector step difference correction information indicating an amount of step difference correction of the detector for performing imaging and defective pixel compensation information indicating a range of defective pixel compensation of the detector for performing imaging.

[0040] The switch may deactivate the virtual IP address of the detector and activate the real IP address of the detector based on the first control information. The detector may further include a display configured to display a change of a state of the detector by using the allocated predetermined marker.

[0041] The receiver may receive second control information from the imaging system. The switch may deactivate the real IP address of the detector and activate the virtual IP address of the detector based on the second control information. The display may display a change of the state of the detector by changing the allocated predetermined marker.

[0042] According to an aspect of an exemplary embodiment, provided is a detector for transmitting detector correction information to an imaging system, the detector including a broadcaster configured to broadcast detector profile information to a network to which the imaging system is connected; a receiver configured to receive, from the imaging system first control information including an allocated predetermined marker; a controller configured to stop the broadcasting by the detector based on the first control information; and a transmitter configured to transmit the detector correction information to the imaging system.

[0043] The detector may further include a display configured to display a change of a state of the detector by using the allocated predetermined marker when the broadcasting by the detector is stopped by the controller.

[0044] The receiver may receive second control information from the imaging system. The broadcaster may start broadcasting of detector profile information to the network based on the second control information. The display may display a change of the state of the detector by changing the allocated predetermined marker when the broadcasting by the detector is started.

[0045] According to an aspect of an exemplary embodiment, provided is a non-transitory computer-readable recording medium having recorded thereon a program for executing the above described methods.

BRIEF DESCRIPTION OF THE DRAWINGS

[0046] The above and/or other aspects will become more apparent by describing certain exemplary embodiments, taken in conjunction with the accompanying drawings in which:

[0047] FIG. 1 is a block diagram of an X-ray apparatus according to an exemplary embodiment;

[0048] FIG. 2 is a perspective view of a fixed type X-ray apparatus according to an exemplary embodiment;

[0049] FIG. 3 is a diagram showing a configuration of a mobile X-ray apparatus capable of performing an X-ray photographing operation substantially without limitation as to place according to an exemplary embodiment;

[0050] FIG. 4 is a diagram showing a detailed configuration of an indirect type detector according to an exemplary embodiment;

[0051] FIG. 5 is a flowchart of a method of setting operating conditions of a detector registered in an imaging system based on detector information pre-stored in the detector according to an exemplary embodiment;

[0052] FIG. 6 is a flowchart of a method in which an imaging system and a detector set operating conditions of the detector based on detector information according to an exemplary embodiment;

[0053] FIG. 7A illustrates an image displayed on an imaging system, which includes an available detector list and a candidate detector list according to an exemplary embodiment;

[0054] FIG. 7B illustrates an image displayed on an imaging system, which includes information on detectors according to an exemplary embodiment;

[0055] FIG. 8 is a flowchart of a method in which an imaging system and a detector set operating conditions of the detector based on detector information according to another exemplary embodiment;

[0056] FIG. 9 illustrates registration of a detector in an imaging system based on detector information pre-stored in the detector when the detector moves into another location according to an exemplary embodiment;

[0057] FIG. 10 is a block diagram of an imaging system for setting operating conditions of a detector registered in the imaging system based on detector information pre-stored in the detector according to an exemplary embodiment;

[0058] FIG. 11 is a block diagram of a detector for transmitting detector correction information to an imaging system in which the detector has been registered based on detector information pre-stored in the detector according to an exemplary embodiment; and

[0059] FIG. 12 is a block diagram of a detector for transmitting detector correction information to an imaging system in which the detector has been registered based on detector information pre-stored in the detector according to another exemplary embodiment.

DETAILED DESCRIPTION

[0060] Certain exemplary embodiment will now be described in greater detail with reference to the accompanying drawings. The matters defined in the specification, such as detailed construction and elements, are provided to assist in a comprehensive understanding of the exemplary embodiment. However, the exemplary embodiments may be embodied in many different forms and should not be construed as being limited to the exemplary embodiments set forth herein; rather, these exemplary embodiments are provided such that this disclosure will be thorough and complete, and will fully convey the concept of the exemplary embodiments to one of ordinary skill in the art. Also, well known functions or constructions are not described in detail since they would obscure the exemplary embodiments with unnecessary detail.

[0061] Hereinafter, the terms used in the specification will be briefly described, and exemplary embodiments will be described in detail.

[0062] The terms used in this specification are those general terms currently widely used in the art in consideration of functions in regard to exemplary embodiments, but the terms may vary according to the intention of one of ordinary skill in the art, precedents, or new technology in the art. Also, specified terms may be selected by the applicant, and in this case, the detailed meaning thereof will be described in the detailed description of exemplary embodiments. Thus, the terms used in the specification should be understood not as simple names but based on the meaning of the terms and the overall description of exemplary embodiments. Expressions such as "at least

one of,” when preceding a list of elements, modify the entire list of elements and do not modify the individual elements of the list.

[0063] In the present specification, the term “image” may denote multi-dimensional data configured by discrete image elements (for example, pixels in a two-dimensional image and voxels in a three-dimensional image). For example, an image may include medical images of an object acquired by an X-ray, a computed tomography (CT), a magnetic resonance imaging (MRI), an ultrasound wave, and other medical image systems.

[0064] Also, in the present specification, an object may include a human being or an animal, or a part of the human being or the animal. For example, the object may include organs, such as the liver, the heart, the uterus, the brain, breasts, the abdomen, or blood vessels. Also, the term “object” may include a phantom. The phantom denotes a material having a volume, a density, and an effective atomic number that is nearly equivalent to those of a living organism, and a phantom according to exemplary embodiments may be a spherical phantom having similar properties to those of the human body.

[0065] In the present specification, the term “user” may include a medical expert, for example, a doctor, a nurse, a medical specialist, and a medical imaging expert, or an engineer managing medical apparatuses; however, exemplary embodiments are not limited thereto.

[0066] An X-ray apparatus is a medical imaging apparatus that acquires images of internal structures of the human body by transmitting an X-ray through the human body. The X-ray apparatus may acquire medical images of a target object more simply within a shorter time than other medical imaging apparatuses including an MRI apparatus and a CT apparatus. Therefore, the X-ray system is widely used in a simple chest photographing, abdomen photographing, skeleton photographing, nasal sinuses photographing, neck soft tissue photographing, and breast photographing.

[0067] FIG. 1 is a block diagram of an X-ray apparatus 100 according to an exemplary embodiment. The X-ray apparatus 100 shown in FIG. 1 may be a fixed-type X-ray apparatus or a moveable X-ray apparatus.

[0068] Referring to FIG. 1, the X-ray apparatus 100 includes a workstation 110, an X-ray irradiator 120, a high voltage generator 121, and a detector 130.

[0069] The workstation 110 includes an inputter 111 through which a user may input commands for manipulating the X-ray apparatus 100 including an X-ray irradiation, and a controller 112 which controls overall operations of the X-ray apparatus 100.

[0070] The high voltage generator 121 generates a high voltage for generating X-rays, and applies the high voltage to an X-ray source 122.

[0071] The X-ray irradiator 120 includes the X-ray source 122 which receives the high voltage applied from the high voltage generator 121 to generate and irradiate the X-ray, and a collimator 123 for guiding a path of the X-ray irradiated from the X-ray source 122.

[0072] The detector 130 detects the X-ray that is irradiated from the X-ray irradiator 120 and transmitted through the object.

[0073] Also, the X-ray apparatus 100 may further include a manipulator 140 including a sound outputter 141 which out-

puts sound representing information relating to a photographing operation such as the X-ray irradiation under a control of the controller 112.

[0074] The workstation 110, the X-ray irradiator 120, the high voltage generator 121, and the detector 130 may be connected to each other via wires or wirelessly. When they are connected to each other wirelessly, a device (not shown) for synchronizing clocks with each other may be further included.

[0075] The inputter 111 may include a keyboard, a mouse, a touch screen, a voice recognizer, a fingerprint recognizer, an iris recognizer, and the like. The user may input a command for irradiating the X-ray via the inputter 111. For example, the inputter 111 may include a switch for inputting the command. The switch may be configured such that the switch needs to be separately manipulated to input an irradiation command for irradiating the X-ray. For example, the irradiation command for irradiating the X-ray may be input only when the switch is pushed twice.

[0076] That is, in an exemplary embodiment, when the user pushes the switch, a prepare command for performing a pre-heating operation for X-ray irradiation may be input through the switch, and when the user pushes the switch once more, the irradiation command for irradiating the X-ray may be substantially input through the switch. When the user manipulates the switch as described above, the inputter 111 generates signals corresponding to the commands input through the switch manipulation, e.g., a prepare signal and an irradiation signal, and outputs the generated signals to the high voltage generator 121 generating a high voltage for generating the X-ray.

[0077] When the high voltage generator 121 receives the prepare signal output from the inputter 111, the high voltage generator 121 starts a pre-heating operation, and when the pre-heating is finished, the high voltage generator 121 outputs a ready signal to the controller 112. In addition, the detector 130 also needs to prepare for detecting the X-ray, and thus, when the high voltage generator 121 receives the prepare signal output from the inputter 111, the high voltage generator 121 outputs the prepare signal to the detector 130 while performing the pre-heating operation, so that the detector 130 may prepare for detecting the X-ray transmitted through the object. The detector 130 prepares for detecting the X-ray in response to the prepare signal, and when the preparing for the detection is finished, the detector 130 outputs a ready signal to the high voltage generator 121 and the controller 112.

[0078] When the pre-heating operation of the high voltage generator 121 is finished, the detector 130 is ready for the detecting the X-ray, and the irradiation signal is output from the inputter 111 to the high voltage generator 121, the high voltage generator 121 generates and applies the high voltage to the X-ray source 122, and the X-ray source 122 irradiates the X-ray.

[0079] When the irradiation signal is output from the inputter 111, the controller 112 may output a sound output signal to the sound outputter 141 so that the sound outputter 141 outputs predetermined sound and the object may recognize the irradiation of X-ray. Also, the sound outputter 141 may output sound representing other information relating to the photographing, in addition to the X-ray irradiation. In FIG. 1, the sound outputter 141 is included in the manipulator 140; however, exemplary embodiments are not limited thereto, and the sound outputter 141 may be located at a different location from the manipulator 140. For example, the sound outputter

141 may be included in the workstation **110**, or may be located on a wall surface of an examination room in which the X-ray photographing of the object is performed.

[0080] The controller **112** controls locations of the X-ray irradiator **120** and the detector **130**, a photographing timing, and photographing conditions according to photographing conditions set by the user.

[0081] In more detail, the controller **112** controls the high voltage generator **121** and the detector **130** according to the command input via the inputter **111** to control an irradiation timing of the X-ray, an intensity of the X-ray, and an irradiation region of the X-ray. Also, the controller **112** adjusts the location of the detector **130** according to a predetermined photographing condition, and controls an operation timing of the detector **130**.

[0082] In addition, the controller **112** generates a medical image of the object by using image data transmitted from the detector **130**. In particular, the controller **121** receives the image data from the detector **130**, and generates the medical image of the object by removing noise in the image data, and adjusting a dynamic range and interleaving of the image data. The controller **112** may include one or more hardware and/or software components. For example, the controller **112** may include one or more of an integrated circuitry, a dedicated circuit, firmware, and/or a processor such as a central processing unit (CPU) which executes software programs stored in a storage, e.g., a memory.

[0083] The X-ray apparatus **100** shown in FIG. 1 may further include an outputter (not shown) for outputting the medical image generated by the controller **112**. The outputter may output information for allowing the user to manipulate the X-ray apparatus **100**, for example, a user interface (UI), user information, or object information. The outputter may include, for example, a printer, a cathode ray tube (CRT) display, a liquid crystal display (LCD), a plasma display panel (PDP), an organic light emitting diode (OLED) display, a field emission display (FED), a light emitting diode (LED) display, a vacuum fluorescent display (VFD), a digital light processing (DLP) display, a primary flight display (PFD), a three-dimensional (3D) display, a transparent display, and other various output devices.

[0084] The workstation **110** shown in FIG. 1 may further include a communicator (not shown) that may be connected to a server **162**, a medical apparatus **164**, and a portable terminal **166** via a network **150**.

[0085] The communicator may be connected to the network **150** via wires or wirelessly to communicate with the external server **162**, the external medical apparatus **164**, or the external portable terminal **166**. The communicator may transmit or receive data relating to diagnosis of the object via the network **150**, and may transmit or receive medical images captured by the external medical apparatus **164**, for example, a CT, an MRI, or an X-ray apparatus. Moreover, the communicator may receive a medical history or a treatment schedule of an object (e.g., a patient) from the server **162** to diagnose a disease of the object. Also, the communicator may perform data communication with the portable terminal **166** such as a mobile phone, a personal digital assistant (PDA), or a laptop computer of, for example, a doctor or a patient, as well as the server **162** or the medical apparatus **164** in a hospital.

[0086] The communicator may include one or more elements for communicating with external apparatuses, for

example, a short distance communication module, a wired communication module, and a wireless communication module.

[0087] The short distance communication module may include a module for communicating with a device located within a predetermined distance. The short distance communication module may use short distance communication technology including, for example, wireless local area network (LAN), Wi-Fi, Bluetooth, Zigbee, Wi-Fi Direct (WFD), ultra wideband (UWB), infrared data association (IrDA), Bluetooth low energy (BLE), near field communication (NFC), or the like; however, exemplary embodiments are not limited thereto.

[0088] The wired communication module may include a module for communicating by using an electric signal or an optical signal, and the wired communication module may use wired communication technology including, for example, wired communication technology using a pair cable, a coaxial cable, or an optical fiber cable, or the like; however, exemplary embodiments are not limited thereto.

[0089] The wireless communication module may transmit and/or receive a wireless signal to/from at least one of a base station, an external device, and a server in a mobile communication network. Here, the wireless signal may be a voice call signal, a video call signal, or various types of data according to transmission of text and/or multimedia messages.

[0090] The X-ray apparatus **100** shown in FIG. 1 may include a plurality of digital signal processors (DSPs) (not shown), an ultra-small calculator (not shown), and a processing circuit (not shown) for specialized usage (for example, a high speed analog/digital (A/D) conversion, a high speed Fourier transformation, an array process, etc.).

[0091] In addition, the communication between the workstation **110** and the X-ray generator **120**, the workstation **110** and the high voltage generator **211**, and the workstation **110** and the detector **130** may use a high speed digital interface including, for example, low voltage differential signaling (LVDS), asynchronous serial communication such as universal asynchronous receiver transmitter (UART), synchronous serial communication, or a low latency network protocol such as a controller area network (CAN), and other various communication methods.

[0092] FIG. 2 is a perspective view of a fixed type X-ray apparatus **200** according to an exemplary embodiment.

[0093] As shown in FIG. 2, the X-ray apparatus **200** includes a manipulator **140** for providing a user with an interface for manipulating the X-ray apparatus **200**, an X-ray irradiator **120** for irradiating the X-ray to an object, a detector **130** for detecting the X-ray passing through the object, first through third motors **211**, **212**, and **213** for providing a driving power to transport the X-ray irradiator **120**, a guide rail **220**, a moving carriage **230**, and a post frame **240** to transport the X-ray irradiator **120** by using the driving power of the motors **211**, **212**, and **213**.

[0094] The guide rail **220** includes a first guide rail **221** and a second guide rail **222** arranged to have a predetermined angle with respect to each other. The first guide rail **221** and the second guide rail **222** may respectively extend in directions to substantially cross each other.

[0095] The first guide rail **221** may be provided on a ceiling of the examination room in which the X-ray apparatus **200** is disposed.

[0096] The second guide rail **222** may be located under the first guide rail **221**, and may be mounted to the first guide rail

221 to slide along the first guide rail **221**. A roller (not shown) that may move along the first guide rail **221** may be provided on the first guide rail **221**. The second guide rail **222** is connected to the roller (not shown) to move along the first guide rail **221**.

[0097] A first direction D1 is defined as a direction in which the first guide rail **221** is extended, and a second direction D2 is defined as a direction in which the second guide rail **222** is extended. The first direction D1 and the second direction D2 may substantially cross each other, and may be substantially parallel to the ceiling of the examination room.

[0098] The moving carriage **230** may be disposed under the second guide rail **222** to move along the second guide rail **222**. A roller (not shown) moving along the second guide rail **222** may be provided on the moving carriage **230**.

[0099] Therefore, the moving carriage **230** may move in the first direction D1 together with the second guide rail **222** along the first guide rail **221**, and may move in the second direction D2 along the second guide rail **222**.

[0100] The post frame **240** may be fixed on the moving carriage **230** and located under the moving carriage **230**. The post frame **240** may include a plurality of posts **241**, **242**, **243**, **244**, and **245**.

[0101] The plurality of posts **241**, **242**, **243**, **244**, and **245** are connected to each other while being insertable into each other. Thus, the post frame **240** may have a length that is adjustable in an up and down direction from the moving carriage **230**.

[0102] A third direction D3 is defined as a direction in which the length of the post frame **240** is increased or reduced. Therefore, the third direction D3 may substantially cross the first direction D1 and the second direction D2.

[0103] The X-ray irradiator **120** may include an X-ray source **122** for generating the X-ray, and a collimator **123** for adjusting an irradiation region of the X-ray that is generated and irradiated from the X-ray source **122**. The X-ray source **122** includes an X-ray tube that may be realized as a diode including a cathode and an anode. An inside of the X-ray tube is set as a higher vacuum state of about 10 mmHg, and a filament of the anode is heated to a higher temperature to generate thermal electrons. The filament may be a tungsten filament, and a voltage of about 10 V and a current of about 3 to 5 A may be applied to an electric wire connected to the filament to heat the filament.

[0104] In addition, when a higher voltage of about 10 to about 300 kVp is applied between the cathode and the anode, the thermal electrons are accelerated to crash onto a target material of the cathode such that an X-ray is generated. The X-ray is irradiated to outside via a window, and the window may be provided as a beryllium thin film. Here, a portion of the energy of the electrons colliding with the target material is consumed as heat, and a remaining portion of the energy is converted into the X-ray.

[0105] The cathode may mainly comprise copper, and the target material may be disposed at an opposite side to the anode. The target material may be a higher resistive material such as, for example, Cr, Fe, Co, Ni, W, or Mo. The target material may be rotated by a rotating field. When the target material is rotated, an electron impact area is increased, and a heat accumulation rate per unit area may be increased about ten times greater than that of a case where the target material is fixed.

[0106] The voltage applied between the cathode and the anode of the X-ray tube is referred to as a tube voltage, and the

tube voltage is applied from the high voltage generator **121** and a magnitude of the tube voltage may be expressed by a crest value thereof (kVp). When the tube voltage increases, a velocity of the thermal electrons increases, and accordingly, an energy of the X-ray (energy of a photon) that is generated when the thermal electrons collide with the target material is increased. A current flowing in the X-ray tube is referred to as a tube current that may be expressed as an average value thereof (mA). When the tube current increases, the number of thermal electrons emitted from the filament is increased, and accordingly, a dose of the X-ray (the number of X-ray photons) generated when the thermal electrons collide with the target material is increased.

[0107] Therefore, the energy of the X-ray may be adjusted according to the tube voltage, and the intensity or dose of the X-ray may be adjusted according to the tube current and a X-ray exposure time.

[0108] The high voltage generator **121** may be within the X-ray source **122**; however, exemplary embodiments are not limited thereto. For example, the high voltage generator **121** may be at another portion of the X-ray apparatus **200**.

[0109] The detector **130** may be a digital detector for detecting the X-ray passing through the object, and may be realized as a table type having a table **290** or a stand type having a stand **280**. The detector **130** may be provided by using a thin film transistor (TFT) or a charge coupled device (CCD).

[0110] A rotating joint **250** may be disposed between the X-ray irradiator **120** and the post frame **240**. The rotating joint **250** allows the X-ray irradiator **120** to be coupled to the post frame **240**, and supports a load applied to the X-ray irradiator **120**.

[0111] The X-ray irradiator **120** connected to the rotating joint **250** may rotate on a plane that is substantially perpendicular to the third direction D3. Here, a rotating direction of the X-ray irradiator **120** may be defined as a fourth direction D4.

[0112] Also, the X-ray irradiator **120** may be configured to be rotatable on a plane substantially perpendicular to the ceiling of the examination room. Here, a rotating direction of the X-ray irradiator **120** may be defined as a fifth direction D5. Therefore, the X-ray irradiator **120** may rotate in the fourth direction D4 or the fifth direction D5 based on an axis that is substantially parallel with the first direction D1 or the second direction D2, with respect to the rotating joint **250**.

[0113] The motors **211**, **212**, and **213** may be provided to move the X-ray irradiator **120** in the first through third directions D1, D2, and D3. The motors **211**, **212**, and **213** may be electrically driven, and the motors **211**, **212**, and **213** may respectively include an encoder.

[0114] The motors **211**, **212**, and **213** may be disposed on various locations in consideration of design convenience. For example, the first motor **211** for moving the second guide rail **222** in the first direction D1 may be disposed around the first guide rail **221**, the second motor **212** for moving the moving carriage **230** in the second direction D2 may be disposed around the second guide rail **222**, and the third motor **213** for increasing or reducing the length of the post frame **240** in the third direction D3 may be disposed in the moving carriage **230**. In another example, the first through third motors **211**, **212**, and **213** may be connected to a driving power transfer unit (not shown) to substantially linearly move the X-ray irradiator **120** in the first through third directions D1, D2, and

D3, respectively. The driving power transfer unit may be, for example, a belt and a pulley, a chain and a sprocket, or a shaft.

[0115] As another example, the motors 211, 212, and 213 may be disposed between the rotating joint 250 and the post frame 240 and between the rotating joint 250 and the X-ray irradiator 120 to rotate the X-ray irradiator 120 in at least one of the fourth direction D4 and the fifth direction D5.

[0116] The manipulator 140 for providing the user with the interface for inputting various information about X-ray photographing and manipulating the X-ray apparatus 200 may be disposed at, for example, a side surface of the X-ray irradiator 120.

[0117] Although FIG. 2 shows the fixed type X-ray apparatus 200 connected to the ceiling of the examination room, the X-ray apparatus 200 of FIG. 2 is merely given as an example for convenience of comprehension. That is, the X-ray apparatus according to exemplary embodiments may be an X-ray apparatus having various structures including, for example, a C-arm-type X-ray apparatus and an angiography X-ray apparatus.

[0118] FIG. 3 is a diagram showing a configuration of a mobile X-ray apparatus 300 capable of performing an X-ray photographing operation substantially without limitation as to place according to an exemplary embodiment.

[0119] The mobile X-ray apparatus 300 shown in FIG. 3 includes a transport part 370 including a wheel for transporting the X-ray apparatus 300, a main part 305 including an inputter 310 through which commands for operating the X-ray apparatus 300 are input, a high voltage generator 340 for generating a high voltage applied to an X-ray source 355, a sound outputter 320 for outputting sound representing information relating to a photographing operation such as an X-ray irradiation, and a controller 330 for controlling overall operations of the X-ray apparatus 300, an X-ray irradiator 350 including the X-ray source 355 generating the X-ray, and a collimator 357 for guiding a path of the X-ray generated and emitted from the X-ray source 355, and a detector 360 for detecting the X-ray irradiated from the X-ray irradiator 350 and transmitted through an object.

[0120] The inputter 310 receives a predetermined input from the user. The inputter 310 may include a keyboard, a mouse, a touch screen, a voice recognizer, a fingerprint recognizer, an iris recognizer, and the like. The user may input a command for irradiating the X-ray via the inputter 310, and the inputter 310 may include a switch for receiving the command input. The switch may be configured to receive the command for irradiating the X-ray when separately manipulated. For example, the switch may receive the command for irradiating the X-ray only when the switch is pushed twice.

[0121] That is, in an exemplary embodiment, when the user pushes the switch, a prepare command for performing a pre-heating operation for X-ray irradiation may be input through the switch, and when the user pushes the switch once more, an irradiation command for irradiating the X-ray may be substantially input through the switch. When the user manipulates the switch as described above, the inputter 310 generates signals corresponding to the commands input through the switch manipulation, e.g., a prepare signal and an irradiation signal, and outputs the generated signals to the high voltage generator 340 generating a high voltage for generating the X-ray.

[0122] When the high voltage generator 340 receives the prepare signal output from the inputter 310, the high voltage generator 340 starts a pre-heating operation, and when the

pre-heating is finished, the high voltage generator 340 outputs a ready signal to the controller 330. In addition, the detector 360 also needs to prepare for detecting the X-ray, and thus, when the high voltage generator 340 receives the prepare signal output from the inputter 310, the high voltage generator 340 outputs the prepare signal to the detector 360 while performing the pre-heating operation, so that the detector 360 may prepare for detecting the X-ray transmitted through the object. The detector 360 prepares for detecting the X-ray in response to the prepare signal, and when the preparing for the detection is finished, the detector 360 outputs a ready signal to the high voltage generator 340 and the controller 330.

[0123] When the pre-heating operation of the high voltage generator 340 is finished, the detector 360 is ready for the detecting the X-ray, and the irradiation signal is output from the inputter 310 to the high voltage generator 340, the high voltage generator 340 generates and applies the high voltage to the X-ray source 355, and the X-ray source 355 irradiates the X-ray. When the irradiation signal is output from the inputter 310, the controller 330 may output a sound output signal to the sound outputter 320 so that the sound outputter 320 outputs predetermined sound and the object may recognize the irradiation of X-ray. Also, the sound outputter 320 may output sound representing other information relating to the photographing, in addition to the X-ray irradiation.

[0124] In FIG. 3, the sound outputter 320 is included in the main part 305; however, exemplary embodiments are not limited thereto. For example, the sound outputter 320 may be located separately from the mobile X-ray apparatus 300 in a place where the mobile X-ray apparatus 300 is located. For example, the sound outputter 320 may be located on a wall surface of a hospital room in which the mobile X-ray apparatus 300 is located.

[0125] The controller 330 controls locations of the X-ray irradiator 350 and the detector 360, a photographing timing, and photographing conditions.

[0126] In addition, the controller 330 generates a medical image of the object by using image data transmitted from the detector 360. In particular, the controller 330 receives the image data from the detector 360, and generates the medical image of the object by removing noise in the image data, and adjusting a dynamic range and interleaving of the image data.

[0127] The main part 305 of the mobile X-ray apparatus 300 shown in FIG. 3 may further include an outputter (not shown) for outputting the medical image generated by the controller 330. The outputter may output information for allowing the user to manipulate the X-ray apparatus 300, for example, a UI, user information, or object information.

[0128] FIG. 4 is a diagram showing a detailed configuration of an indirect type detector 400 according to an exemplary embodiment.

[0129] Referring to FIG. 4, the detector 400 may include a scintillator (not shown), a photodetecting substrate 410, a bias driver 430, a gate driver 450, and a signal processor 470.

[0130] The scintillator receives the X-ray irradiated from the X-ray source 122 and converts the X-ray into light.

[0131] The photodetecting substrate 410 receives the light from the scintillator and converts the light into a photodetecting voltage. The photodetecting substrate 410 may include gate lines GL, data lines DL, thin film transistors (TFTs) 412, photodiodes 414, and bias lines BL.

[0132] The gate lines GL may extend in a first direction D1, and the data lines DL may extend in a second direction D2 that substantially crosses the first direction D1. The first direction

D1 and the second direction D2 may be substantially perpendicular to each other. FIG. 2 shows four gate lines GL and four data lines DL as an example.

[0133] The TFTs 412 may be arranged as a matrix in the first and second directions D1 and D2. Each of the TFTs 412 may be electrically connected to one of the gate lines GL and one of the data lines DL. A gate of the TFT 412 may be electrically connected to the gate line GL, and a source of the TFT 412 may be electrically connected to the data line DL. In FIG. 2, sixteen (i.e., 4×4) TFTs 412 are shown as an example.

[0134] The photodiodes 414 may be arranged as a matrix in the first and second directions D1 and D2 to correspond to the TFTs 412 in a one-to-one correspondence. Each of the photodiodes 414 may be electrically connected to one of the TFTs 412. An N-side electrode of each of the photodiodes 414 may be electrically connected to a drain of each TFT 412. FIG. 2 shows sixteen (i.e., 4×4) photodiodes 414 as an example.

[0135] Each of the photodiodes 414 receives the light from the scintillator and converts the light into the photodetecting voltage. The photodetecting voltage may correspond to an intensity of the X-ray.

[0136] The bias lines BL are electrically connected to the photodiodes 414. Each of the bias lines BL may be electrically connected to a P-side electrode of each of the photodiodes 414. For example, the bias lines BL may extend substantially parallel with the second direction D2 to be electrically connected to the photodiodes 414. Alternatively, the bias lines BL may extend substantially parallel with the first direction D1 to be electrically connected to the photodiodes 414. FIG. 2 shows four bias lines BL which extend along the second direction D2 as an example.

[0137] The bias driver 430 is electrically connected to the bias lines BL to apply a driving voltage to the bias lines BL. The bias driver 430 may selectively apply a reverse bias or a forward bias to the photodiodes 414 through the bias lines BL. A reference voltage may be applied to the N-side electrode of the photodiode 414. The bias driver 430 may apply a voltage that is less than the reference voltage to the P-side electrode of the photodiode 414 to apply a reverse bias to the photodiode 414. Alternatively, the bias driver 430 may apply a voltage that is greater than the reference voltage to the P-side electrode of the photodiode 414 to apply a forward bias to the photodiode 414.

[0138] The gate driver 450 is electrically connected to the gate lines GL to apply gate signals to the gate lines GL. The gate driver 450 sequentially applies the gate signals to the gate lines GL along the second direction D2. For example, when the gate signals are applied to the gate lines GL, the gate signals may turn on the TFTs 412. On the other hand, when the gate signals are not applied to the gate lines GL, the gate signals may turn off the TFTs 412.

[0139] The signal processor 470 is electrically connected to the data lines DL to receive sample input voltages from the data lines DL. The signal processor 470 may output image data to the outside by using the sample input voltages. The image data may be an analog signal or a digital signal corresponding to the photodetecting voltage. The signal processor 470 may include one or more hardware and/or software components. For example, the signal processor 470 may include one or more of an integrated circuitry, a dedicated circuit, firmware, and/or a processor such as a central processing unit (CPU) which executes software programs stored in a storage, e.g., a memory.

[0140] Although not shown in FIG. 4, when the detector 400 shown in FIG. 4 is a wireless detector, the detector 400 may further include a battery and a wireless communication interface.

[0141] A wired detector is associated with a receptor (or tray) of a stand or a table, and thus cannot be moved freely. On the other hand, a wireless detector may be easily moved and thus may be moved from an imaging system currently being used to another imaging system. When a detector is moved to a new imaging system, various information are needed to use the detector in connection with the new imaging system. The various information need to be all stored in the new imaging system. For example, the various information may include an Internet Protocol (IP) address, a type, and a serial number of the detector, and the like.

[0142] When the moved detector is not registered in the new imaging system, the moved detector may not be immediately used, and may be used by setting detector information on the new imaging system. In other words, to use a detector not registered in an imaging system, the imaging system needs to be connected to the detector via the IP address of the detector, and the type, serial number, and correction information of the detector need to be informed to the imaging system and stored therein. A process of collecting the information may be included in a process of setting operation conditions of the detector.

[0143] According to the related art, to perform detector information setting, a user needs to directly execute an installation program or the like and manually set detector information using the installation program or the like, or needs to acquire information about a detector from another imaging system on a network and set operation conditions of the detector based on the acquired information.

[0144] According to an exemplary embodiment, to use a detector not registered in an imaging system during imaging, information about the detector may be acquired from another imaging system, or a user may register the detector in the imaging system by using information stored in the detector without executing a separate installation program, and the operation conditions of the detector may be automatically set on the imaging system.

[0145] FIG. 5 is a flowchart of a method of setting operation conditions of a detector registered in an imaging system based on detector information pre-stored in the detector according to an exemplary embodiment. FIG. 6 is a flowchart of a method in which an imaging system 1000 and a detector 2000 set operating conditions of the detector 2000 based on detector information according to an exemplary embodiment.

[0146] Referring to FIG. 5, the method may include searching for a detector that is to be registered (S100), acquiring detector profile information from a found detector (S200), registering the detector based on the acquired detector profile information (S300), allocating a predetermined marker to represent activation or non-activation of the registered detector (S400), transmitting control information including the allocated marker to the detector (S500), receiving detector correction information from the detector (S600), and setting operating conditions of the detector based on the received detector correction information (S700). The detector information may include the detector profile information and the detector correction information.

[0147] Referring to FIG. 6, the imaging system 1000 according to an exemplary embodiment may be included in a

workstation. Alternatively, the imaging system **1000** may exist separately from the workstation.

[0148] Operations **S100** to **S700** in FIG. **6** are substantially the same or similar to those described above with respect to FIG. **5** and thus any repetitive explanation will be omitted.

[0149] Operation **S100** of searching for a detector to be registered may include searching for a virtual IP address of the detector **2000**, which is to be registered (**S110**) and accessing the detector **2000** via a found virtual IP address (**S120**).

[0150] A detector according to an exemplary embodiment may be allocated a real IP address and a virtual IP address for each media access control (MAC) address. A real IP address may be uniquely allocated to each detector, and an identical virtual IP address may be allocated to a plurality of detectors. In other words, different real IP addresses may be allocated to different detectors, and an identical virtual IP address may be allocated to a plurality of detectors.

[0151] The imaging system **1000** may perform data communications with a detector already registered on the imaging system **1000** via a real IP address, and may determine, via a virtual IP address, whether a detector currently not registered on the imaging system **1000** exists. The imaging system **1000** may access the to-be-registered detector **2000** via the found virtual IP address.

[0152] After accessing the detector **2000**, the imaging system **1000** may acquire detector profile information from the detector **2000**. For example, the imaging system **1000** may receive the detector profile information from the detector **2000** via the virtual IP address. The detector profile information may include at least one of a real IP address, a type, and a serial number of the detector **2000**.

[0153] Operation **S300** of registering a detector may include storing the detector profile information on a candidate detector list to an available detector list on the imaging system **1000**.

[0154] A predetermined marker according to an exemplary embodiment may include at least one of a character, a number, a symbol, a color, and an image.

[0155] Referring back to FIG. **5**, a predetermined marker may be allocated to the detector **2000** registered in the imaging system **1000** (**S400**). The imaging system **1000** may allocate the predetermined marker to the registered detector **2000** so that the allocated marker is used as an identifier of the detector **2000**.

[0156] The control information including the allocated marker may be transmitted to the detector **2000** (**S500**).

[0157] The imaging system **1000** may receive the detector correction information from the detector **2000** (**S600**). Operation **S600** of receiving the detector correction information from the detector **2000** may include receiving the detector correction information from the detector **2000** via an access to an activated real IP address of the detector **2000**. For example, since the detector **2000** switches from a virtual IP address to a real IP address in response to the control information including the allocated marker and transmits the detector correction information to the imaging system **1000** via the real IP address, the imaging system **1000** may receive the detector correction information from the detector **2000**.

[0158] The operating conditions of the detector **2000** may be set based on the received detector correction information (**S700**). Operation **S700** of setting the operating conditions of the detector **2000** may include setting imaging conditions for

performing imaging using the detector **2000**, based on the detector correction information received from the detector **2000**.

[0159] For example, the operating conditions of the detector **2000** may be referred to as an operating environment of the detector **2000** when X-ray imaging is being performed using the detector **2000**, such as, an amount of step difference correction of the detector **2000** during imaging and a range of defective pixel compensation.

[0160] In this case, the detector correction information may include at least one of detector step difference correction information and defective pixel compensation information. As described above, the detector information may include the detector profile information and the detector correction information.

[0161] FIG. **7A** illustrates an image **701** of the imaging system **1000** including an available detector list **710** and a candidate detector list **720** according to an exemplary embodiment. FIG. **7B** illustrates an image displayed on an imaging system, which includes information on detectors according to an exemplary embodiment.

[0162] As illustrated in FIG. **7A**, a display (not shown) of the imaging system **1000** may display the image **701**, which includes the available detector list **710** and the candidate detector list **720**.

[0163] The available detector list **710** includes information about at least one detector currently registered (or identified) on the imaging system **1000**. The candidate detector list **720** includes information about at least one detector not yet registered on the imaging system **1000**.

[0164] As described above, the detector profile information of the to-be-registered detector acquired via the virtual IP address may be displayed to a user in the form of the candidate detector list **720**. A detector may be registered in the imaging system **1000** by storing, in the available detector list **710**, the detector profile information of the detector displayed on the candidate detector list **720**.

[0165] In addition, a predetermined detector may be deregistered from the imaging system **1000**, based on a user input via an external input receiver (not shown) or the like that may be connected to the imaging system **1000**. When a detector is deregistered, information about the deregistered detector may be deleted from the available detector list **710**. The information deleted from the available detector list **710** may be included in the candidate detector list **720**, or may also be deleted from the candidate detector list **720**.

[0166] As illustrated in FIGS. **7A** and **7B**, with respect to a detector **2001** or **2002** registered in the imaging system **1000**, real IP address thereof may be activated. For example, the real IP address of the detector **2001**, namely, 192.168.197.80, may be activated so that the detector **2001** may communicate with the imaging system **1000**. The real IP address of the detector **2002**, namely, 192.168.197.81, may be activated so that the detector **2002** may communicate with the imaging system **1000**.

[0167] The detector **2001** or **2002** may display a registration or non-registration status thereof in the imaging system **1000** by using an allocated marker **2021** or **2022**. For example, the allocated marker **2021** or **2022** may be displayed in a predetermined pattern via a display of the detector **2001** or **2002**. For example, the predetermined pattern may include a pattern in which at least one of, for example, a size, a position, and a color of the allocated marker **2021** or **2022** is changed during a predetermined period of time, a pattern in

which the allocated marker **2021** or **2022** flickers during a predetermined period of time, or any other patterns. When a predetermined color, e.g., a yellow color is allocated to the detector **2001** registered in the imaging system **1000**, the detector **2001** may display the marker **2021** in the yellow color on the display. When a predetermined color, e.g., a violet color is allocated to the detector **2002** registered in the imaging system **1000**, the detector **2002** may display the marker **2022** in the violet color on the display. In other words, the detector **2001** or **2002** registered in the imaging system **1000** may display registration or non-registration thereof in the imaging system **1000** by using the allocated marker **2021** or **2022**.

[0168] With respect to a detector **2003** not yet registered in the imaging system **1000**, a virtual IP address thereof may be activated. For example, the virtual IP address of the detector **2003**, namely, 192.168.197.1, may be activated so that the detector **2003** may communicate with the imaging system **1000**. In other words, the imaging system **1000** may search for the unregistered detector **2003** by searching for the virtual IP address of the unregistered detector **2003**.

[0169] The detector **2003** not yet registered in the imaging system **1000** may not display any marker or may display a marker **2023** for indicating non-registration of the detector **2003**. For example, the marker **2023** may comprise a marker for alarming, which may be a red light or the like.

[0170] Referring back to FIG. 6, a method of transmitting detector correction information of the detector **2000** to the imaging system **1000** in which the detector **2000** has been registered based on the detector information pre-stored in the detector **2000** according to an exemplary embodiment may include receiving an access request for accessing the detector **2000** via the virtual IP address from the imaging system **1000** (**S1000**), transmitting the detector profile information to the imaging system **1000** (**S2000**), receiving first control information including an allocated predetermined marker from the imaging system **1000** (**S3000**), switching the IP address of the detector **2000** based on the received first control information (**S4000**), and transmitting the detector correction information to the imaging system **1000** in response to a detector correction information transmission request from the imaging system **1000** (**S5000**). The detector information may include the detector profile information and the detector correction information.

[0171] The detector profile information may include at least one of a real IP address, a type, and a serial number of the detector **2000**. The predetermined marker may include at least one of a character, a number, a symbol, a color, and an image. The detector correction information may include at least one of detector step difference correction information and defective pixel compensation information.

[0172] Operation **S4000** of switching the IP address of the detector **2000** based on the received first control information may include deactivating the virtual IP address of the detector **2000** and activating the real IP address thereof, and displaying a state change of the detector **2000** by using the received predetermined marker.

[0173] The method of transmitting the detector correction information of the detector **2000** to the imaging system **1000** in which the detector **2000** has been registered based on the detector information pre-stored in the detector **2000** may further include receiving second control information from the imaging system **1000** (**S6000**), deactivating the real IP address and activating the virtual IP address based on the

second control information (**S7000**), and changing the marker to display a change of the state of the detector (**S8000**).

[0174] As described above with reference to operation **S500**, the imaging system **1000** may transmit the control information to the detector **2000**. The control information transmitted in operation **S500** may include the first control information and the second control information. Alternatively, the control information transmitted in operation **S500** may include the first control information and the control information transmitted in operation **S800** may include the second control information.

[0175] For example, the second control information may include a command or the like for deregistering the detector **2000**. In response to the second control information transmitted at operation **S800**, the detector **2000** may switch an IP address thereof (**S7000**). For example, when the detector **2000** of which the real IP address has been activated and the virtual IP address has been deactivated receives the second control information including, for example, a command for deregistering the detector **2000**, the detector **2000** may deactivate the real IP address and activate the virtual IP address.

[0176] FIG. 8 is a flowchart of a method in which the imaging system **1000** and the detector **2000** set operating conditions of the detector **2000** based on detector information according to another exemplary embodiment.

[0177] Referring to FIG. 8, operation **S100** of searching for a detector **2000** that is to be registered may include determining existence or absence of detector profile information that is being broadcast on a wired or wireless network including the imaging system **1000** (**S130**) and accessing the detector **2000** that is not yet registered and corresponds to the detector profile information that is being broadcast on the wired or wireless network (**S140**).

[0178] The detector **2000** not yet registered in the imaging system **1000** may broadcast the detector profile information to different devices (e.g., another imaging system or another detector) via the wired or wireless network including the imaging system **1000** and the detector **2000**. On the other hand, a detector already registered in the imaging system **1000** may perform unicast communications with the imaging system **1000**.

[0179] The imaging system **1000** may determine existence or absence of detector profile information that is being broadcast, and determine existence or absence of an unregistered detector according to the determination of existence or absence of detector profile information.

[0180] When the detector profile information being broadcast exists, the imaging system **1000** may determine that an unregistered detector exists on the wired or wireless network including the imaging system **1000**. On the other hand, when the detector profile information being broadcast does not exist, the imaging system **1000** may determine that no unregistered detectors exist on the wired or wireless network including the imaging system **1000**, and may continue the operation **S100** of searching for a detector that is to be registered.

[0181] When it is determined in operation **S130** that the detector profile information being broadcast exists, the imaging system **1000** may access the detector **200** corresponding to the broadcast detector profile information (**S140**).

[0182] Operation **S200** of acquiring the detector profile information may include receiving the broadcast detector profile information from the detector **2000** that is not yet

registered (S210) and storing the detector profile information in a candidate detector list (S220). The detector profile information may include at least one of a real IP address, a type, and a serial number of the detector 2000.

[0183] Operation S300 of registering the detector 2000 may include storing the detector profile information on the candidate detector list to an available detector list on the imaging system 1000.

[0184] After a predetermined marker is allocated to the detector 2000 (S400) and control information including the allocated marker is transmitted to the detector 2000 (S500), the imaging system 1000 may receive detector correction information from the detector 2000 (S600).

[0185] Operation S600 of receiving the detector correction information from the detector 2000 may include receiving detector correction information from the detector 2000 of which the detector profile information has been stored in the available detector list in the detector registration operation S300. Operation S700 of setting the operating conditions of the detector 2000 may include setting imaging conditions for performing imaging using the detector 2000, based on the received detector correction information. The detector correction information may include at least one of detector step difference correction information and defective pixel compensation information.

[0186] A method of transmitting the detector correction information of the detector 2000 to the imaging system 1000 in which the detector 2000 has been registered based on the detector information pre-stored in the detector 2000 according to an exemplary embodiment may include broadcasting the detector profile information to the wired or wireless network including the imaging system 1000 (S900), receiving first control information including an allocated predetermined marker from the imaging system 1000 (S3000), stopping the broadcasting by the detector 2000 based on the received first control information (S4100), and transmitting the detector correction information to the imaging system 1000 in response to a detector correction information transmission request from the imaging system 1000 (S5000). The detector information may include the detector profile information and the detector correction information.

[0187] The method of transmitting the detector correction information of the detector 2000 to the imaging system 1000 in which the detector 2000 has been registered based on the detector information pre-stored in the detector 2000 may further include receiving an access request from the imaging system 1000 (S1000) and transmitting the detector profile information to the imaging system 1000 (S2000).

[0188] Operation S4100 of stopping the broadcasting by the detector 2000 based on the received first control information may include displaying a change of the state of the detector 2000 by using the received predetermined marker.

[0189] The method of transmitting the detector correction information to the imaging system 1000 based on the detector information pre-stored in the detector 2000 may further include receiving second control information from the imaging system 1000 (S6000), starting the broadcasting of the detector profile information to the wired or wireless network based on the received second control information (S7100), and changing the marker to display a change of the state of the detector 2000 (S8000).

[0190] FIG. 9 illustrates registration of a detector in an imaging system based on detector information pre-stored in

the detector when the detector moves into another location according to an exemplary embodiment.

[0191] For example, the second control information may be transmitted to a detector 2003 that has been registered in and used in the imaging system 1000 of a first imaging space 910 (or room 1) so that the detector 2003 may be deregistered. When the detector 2003 is deregistered, the imaging system 1000 may not access the detector 2003 via the real IP address and may only access the detector 2003 via the virtual IP address. Due to the deregistration of the detector 2003, the state of the detector 2003 is changed, and thus the detector 2003 may display a predetermined marker in a predetermined pattern. For example, on a display 2013 of the detector 2003, a red light may flicker at time intervals of, for example, one or two seconds to represent the deregistration of the detector 2003.

[0192] When a user moves the detector 2003 to a second imaging space 920 (or room 2), an imaging system 3000 of the second imaging space 920 (or room 2) may perform operation S100 of searching for a to-be-registered detector, to determine whether a detector to be registered exists within the second imaging space 920. In other words, the imaging system 3000 may search for a detector that is accessible via a virtual IP address thereof.

[0193] The imaging system 3000 of the second imaging space 920 acquires detector profile information from a found detector, namely, the detector 2003, and registers the found detector 2003. When the detector 2003 is registered in the imaging system 3000 of the second imaging space 920, the real IP address of the detector 2003 may be activated, and the virtual IP address thereof may be deactivated. Due to the registration of the detector 2003, the activation state of the IP address of the detector 2003 is changed, and thus the detector 2003 may display a predetermined marker in a predetermined pattern. For example, a blue light is turned on, on the display 2013 of the detector 2003.

[0194] The imaging system 3000 of the second imaging space 920 may allocate a predetermined marker to the detector 2003, transmit control information including the allocated marker to the detector 2003, and receive detector correction information from the detector 2003.

[0195] The imaging system 3000 of the second imaging space 920 may set operating conditions of the detector 2003 within the second imaging space 920, based on the received detector correction information. The set operating conditions may be stored in a storage (not shown) included in the imaging system 3000. Alternatively, the set operating conditions may exist separately from the imaging system 3000 and may be stored in a storage (not shown) connected to the imaging system 3000.

[0196] According to another example, the second control information may be transmitted to the detector 2003 that has been registered and used in the imaging system 1000 of the first imaging space 910 (or room 1) so that the detector 2003 may be deregistered. The detector deregistered from the imaging system 1000 of the first imaging space 910 may broadcast the detector profile information to the wired or wireless network. For example, the detector 2003 may broadcast the detector profile information to other devices existing on the wired or wireless network, via an IP address for broadcasting.

[0197] Due to the deregistration of the detector 2003, the state of the detector 2003 is changed, and thus the detector 2003 may display a predetermined marker in a predetermined

pattern. For example, on the display **2013** of the detector **2003**, a red light may flicker at time intervals of one or two seconds to represent the deregistration of the detector **2003**.

[**0198**] When a user moves the detector **2003** to the second imaging space **920** (or room 2), the imaging system **3000** of the second imaging space **920** may determine whether detector profile information being broadcast on the wired or wireless network exists, and may access a detector that exists on the wired or wireless network and broadcasts the detector profile information thereof. In other words, the imaging system **3000** of the second imaging space **920** may perform operation **S100** of searching for a to-be-registered detector, to determine whether a detector that broadcasts the detector profile information exists on the wired or wireless network.

[**0199**] The imaging system **3000** of the second imaging space **920** acquires detector profile information from a found detector, namely, the detector **2003**, and registers the detector **2003**. When the detector **2003** is registered in the imaging system **3000** of the second imaging space **920**, the broadcasting of the detector profile information by the detector **2003** may be stopped.

[**0200**] To represent the stoppage of the broadcasting by the detector **2003**, the detector **2003** may display a predetermined marker in a predetermined pattern. For example, a blue light is turned on, on the display **2013** of the detector **2003**.

[**0201**] The imaging system **3000** of the second imaging space **920** may allocate a predetermined marker to the detector **2003**, transmit control information including the allocated marker to the detector **2003**, and receive detector correction information from the detector **2003**.

[**0202**] The imaging system **3000** of the second imaging space **920** may set operating conditions of the detector **2003** within the second imaging space **920**, based on the received detector correction information. The set operating conditions may be stored in the storage (not shown) included in the imaging system **3000**. Alternatively, the set operating conditions may exist separately from the imaging system **3000** and may be stored in a storage (not shown) connected to the imaging system **3000**.

[**0203**] FIG. **10** is a block diagram of an imaging system **1000** for setting operation conditions of a detector registered in the imaging system **1000** based on detector information pre-stored in the detector according to an exemplary embodiment.

[**0204**] Referring to FIG. **10**, the imaging system **1000** may include a searcher **1100** which searches for a detector that is to be registered, a profile information acquirer **1200** which acquires detector profile information from a found detector, a registrator **1300** which registers the detector based on the acquired detector profile information, an allocator **1400** which allocates a predetermined marker to represent activation or non-activation of the registered detector, a transmitter **1500** which transmits control information including the allocated marker to the detector, a receiver **1600** which receives detector correction information from the detector, and a setter **1700** which sets operating conditions of the detector based on the received detector correction information.

[**0205**] The detector information may include, for example, the detector profile information and the detector correction information.

[**0206**] The searcher **1100** may search for a virtual IP address of the detector that is to be registered, and may access the detector that is to be registered via a found virtual IP address.

[**0207**] The detector profile information may include at least one of the real IP address of the detector, the type thereof, and the serial number thereof, and the registrator **1300** may store the detector profile information on a candidate detector list to an available detector list on the imaging system **1000**. The detector profile information may be stored in a storage (not shown) included in the imaging system **1000**. Alternatively, the detector profile information may exist separately from the imaging system **1000**, but may be stored in a storage (not shown) connected to the imaging system **1000**.

[**0208**] The predetermined marker may include at least one of a character, a number, a symbol, a color, and an image.

[**0209**] The receiver **1600** may receive the detector correction information from the detector by accessing an activated real IP address of the detector. The setter **1700** may set imaging conditions for performing imaging using the detector, based on the detector correction information received from the detector. The detector correction information may include at least one of detector step difference correction information and defective pixel compensation information.

[**0210**] The searcher **1100** may further include a determinator **1110** which determines whether detector profile information being broadcast on a wired or wireless network including the imaging system exists. The searcher **1100** may access an unregistered detector corresponding to the detector profile information that is being broadcast on the wired or wireless network.

[**0211**] The profile information acquirer **1200** may receive the detector profile information from the unregistered detector and may store the detector profile information in a candidate detector list. The detector profile information may include at least one of the real IP address of the detector, the type thereof, and the serial number thereof.

[**0212**] The registrator **1300** may store the detector profile information on the candidate detector list to an available detector list on the imaging system **1000**.

[**0213**] The receiver **1600** may receive detector correction information from the detector of which the detector profile information has been stored in the available detector list. The setter **1700** may set imaging conditions for performing imaging using the detector, based on the received detector correction information. The detector correction information may include at least one of detector step difference correction information and defective pixel compensation information.

[**0214**] One or more of the above elements **1100** to **1700** may be implemented with at least one processor module. For example, one or more of the above elements **1100** to **1700** may be implemented as an array of a plurality of logic gates, or may be implemented as a combination of a general-use microprocessor and a memory that stores a program executable by the microprocessor. Also, one or more of the above elements **1100** to **1700** may be implemented as an application program module.

[**0215**] FIG. **11** is a block diagram of a detector **2000** for transmitting detector correction information to an imaging system in which the detector **2000** has been registered based on detector information pre-stored in the detector **2000** according to an exemplary embodiment.

[**0216**] Referring to FIG. **11**, the detector **2000** may include a receiver **2100** which receives an access request for accessing the detector **2000** via a virtual IP address from the imaging system, and a transmitter **2200** which transmits detector profile information of the registered detector **2000** to the imaging system. The receiver **2100** may receive first control informa-

tion including a predetermined marker, from the imaging system. The detector **2000** may further include a switch **2300** which switches the IP address of the detector **2000** based on the received first control information. The transmitter **2200** may also transmit detector correction information to the imaging system, in response to a detector correction information transmission request from the imaging system. The detector information may include the detector profile information and the detector correction information.

[0217] The detector **2000** may further include a storage **2500** which stores the detector profile information, the marker, or the detector correction information.

[0218] The detector profile information may include, for example, at least one of the real IP address of the detector **2000**, the type thereof, and the serial number thereof. The marker may include, for example, at least one of a character, a number, a symbol, a color, and an image. The detector correction information may include, for example, at least one of detector step difference correction information and defective pixel compensation information.

[0219] The switch **2300** may deactivate the virtual IP address of the detector **2000** and activate the real IP address of the detector **2000**. The detector **2000** may further include a display **2400** which displays a change of the state of the detector **2000** by using a received predetermined marker.

[0220] The receiver **2100** may receive second control information from the imaging system, and the switch **2300** may deactivate the real IP address of the detector **2000** and activate the virtual IP address of the detector **2000**, based on the received second control information.

[0221] The display **2400** may display a change of the state of the detector **2000** by changing the received marker.

[0222] One or more of the above elements **2100** to **2500** may be implemented with at least one processor module. For example, one or more of the above elements **2100** to **2500** may be implemented as an array of a plurality of logic gates, or may be implemented as a combination of a general-use microprocessor and a memory that stores a program executable by the microprocessor. Also, one or more of the above elements **2100** to **2500** may be implemented as an application program module.

[0223] FIG. 12 is a block diagram of a detector **2000** for transmitting detector correction information to an imaging system in which the detector **2000** has been registered based on detector information pre-stored in the detector **2000** according to another exemplary embodiment.

[0224] Referring to FIG. 12, the detector **2000** may include a broadcaster **2210** which broadcasts detector profile information of the detector **2000** to a wired or wireless network including the imaging system, a receiver **2100** which receives first control information including an allocated predetermined marker from the imaging system, a controller **2600** which stops the broadcasting by the detector **2000** based on the received first control information, and a transmitter **2200** which transmits the detector correction information to the imaging system in response to a detector correction information transmission request from the imaging system. The detector information may include the detector profile information and the detector correction information.

[0225] The detector **2000** may further include a display **2400** which displays a change of the state of the detector **2000** by using a received predetermined marker when the broadcasting by the detector **2000** is stopped by the controller **2600**.

[0226] The controller **2600** may include one or more hardware and/or software components. For example, the controller **2600** may include one or more of an integrated circuitry, a dedicated circuit, firmware, and/or a processor such as a central processing unit (CPU) which executes software programs stored in a storage, e.g., a memory.

[0227] The detector **2000** may further include a storage **2500** which stores the detector profile information, the marker, or the detector correction information.

[0228] The receiver **2100** may receive second control information from the imaging system, and the broadcaster **2210** may start broadcasting of detector profile information to the wired or wireless network, based on the received second control information. The display **2400** may display a change of the state of the detector **2000** by changing the marker.

[0229] The above-described methods according to exemplary embodiments may be applied to the imaging system **1000** of FIG. 10 and the detectors **2000** of FIGS. 11 and 12. Therefore, any repetitive explanation of the imaging system **1000** and the detectors **2000** will be omitted.

[0230] Exemplary embodiments may also be implemented through computer-readable recording media having recorded thereon computer-executable instructions such as program modules that are executed by a computer, which include at least one processor. Computer-readable media may be any available media that can be accessed by a computer and include both volatile and nonvolatile media and both detachable and non-detachable media. Examples of the computer-readable media may include a read-only memory (ROM), a random-access memory (RAM), a compact disc (CD)-ROM, a magnetic tape, a floppy disk, an optical data storage device, etc. Furthermore, the computer-readable media may include computer storage media and communication media. The computer storage media include both volatile and nonvolatile and both detachable and non-detachable media implemented by any method or technique for storing information such as computer-readable instructions, data structures, program modules or other data. The communication media typically embody computer-readable instructions, data structures, program modules, other data of a modulated data signal such as a carrier wave, or other transmission mechanism, and they include any information transmission media.

[0231] While the exemplary embodiments have been particularly shown and described with reference to exemplary embodiments thereof, it will be understood by those of ordinary skill in the art that various changes in form and details may be made therein without departing from the spirit and scope as defined by the following claims.

What is claimed is:

1. A method of setting operating conditions of a detector in an imaging system, the method comprising:
 - searching for a detector that is not registered in the imaging system;
 - acquiring detector profile information from the searched detector;
 - registering the detector based on the detector profile information;
 - allocating a predetermined marker to the registered detector to represent activation or non-activation thereof;
 - transmitting control information including the allocated predetermined marker to the detector;
 - receiving detector correction information from the detector; and

- setting operating conditions of the detector based on the received detector correction information.
2. The method of claim 1, wherein the searching comprises:
- searching for a virtual Internet Protocol (IP) address of the detector that is not registered in the imaging system; and accessing the detector by using the searched virtual IP address.
3. The method of claim 2, wherein
- the detector profile information comprises at least one from among a real IP address, a type, and a serial number of the detector, and
 - the registering comprises storing the detector profile information to an available detector list of the imaging system.
4. The method of claim 3, wherein
- the receiving comprises receiving the detector correction information from the detector via an access to an activated real IP address of the detector,
 - the setting comprises setting imaging conditions for performing imaging using the detector based on the detector correction information, and
 - the detector correction information comprises at least one from among detector step difference correction information indicating an amount of step difference correction of the detector for performing imaging and defective pixel compensation information indicating a range of defective pixel compensation of the detector for performing imaging.
5. The method of claim 1, wherein the predetermined marker comprises at least one from among a character, a number, a symbol, a color, and an image.
6. The method of claim 1, wherein
- the searching comprises:
 - determining whether detector profile information is broadcast on a network to which the imaging system is connected; and
 - accessing an unregistered detector corresponding to the detector profile information that is being broadcast on the network,
 - the acquiring comprises:
 - receiving the broadcast detector profile information from the unregistered detector; and
 - storing the detector profile information in a candidate detector list, and
 - the detector profile information comprises at least one from among a real IP address, a type, and a serial number of the unregistered detector.
7. The method of claim 6, wherein the registering comprises storing the detector profile information on the candidate detector list to an available detector list of the imaging system.
8. The method of claim 7, wherein
- the receiving comprises receiving detector correction information from the detector having the detector profile information stored in the available detector list,
 - the setting comprises setting imaging conditions for performing imaging using the detector based on the detector correction information, and
 - the detector correction information comprises at least one from among detector step difference correction information indicating an amount of step difference correction of the detector for performing imaging and defective pixel compensation information indicating a range of defective pixel compensation of the detector for performing imaging.
9. A method of transmitting detector correction information of a detector to an imaging system, the method comprising:
- receiving, from the imaging system, a request to access the detector via a virtual IP address of the detector;
 - transmitting detector profile information of the detector to the imaging system in response to the request;
 - receiving, from the imaging system, first control information including an allocated predetermined marker;
 - switching the virtual IP address of the detector based on the first control information; and
 - transmitting the detector correction information to the imaging system.
10. The method of claim 9, wherein the detector profile information comprises at least one from among a real IP address, a type, and a serial number of the detector, the predetermined marker comprises at least one from among a character, a number, a symbol, a color, and an image, and the detector correction information comprises at least one from among detector step difference correction information indicating an amount of step difference correction of the detector for performing imaging and defective pixel compensation information indicating a range of defective pixel compensation of the detector for performing imaging.
11. The method of claim 10, wherein the switching comprises:
- deactivating the virtual IP address of the detector and activating the real IP address of the detector; and
 - displaying a change of a state of the detector by using the allocated predetermined marker.
12. The method of claim 11, further comprising:
- receiving second control information from the imaging system;
 - deactivating the real IP address of the detector and activating the virtual IP address of the detector based on the second control information; and
 - displaying a change of the state of the detector by using the allocated predetermined marker.
13. A method of transmitting detector correction information of a detector to an imaging system, the method comprising:
- broadcasting detector profile information to a network to which the imaging system is connected;
 - receiving, from the imaging system, first control information including an allocated predetermined marker; and
 - stopping the broadcasting and transmitting, from the detector, the detector correction information to the imaging system based on the first control information.
14. The method of claim 13, wherein the stopping comprises displaying a change of a state of the detector by using the allocated predetermined marker.
15. The method of claim 14, further comprising:
- receiving second control information from the imaging system;
 - starting broadcasting of the detector profile information to the network based on the second control information; and
 - displaying a change of the state of the detector by using the allocated predetermined marker.
16. An imaging system for setting operating conditions of a detector, the imaging system comprising:

- a searcher configured to search for a detector that is not registered in the imaging system;
- a detector profile information acquirer configured to acquire detector profile information about the searched detector;
- a registrar configured to register the detector based on the detector profile information;
- an allocator configured to allocate a predetermined marker to the detector to represent activation or non-activation thereof;
- a transmitter configured to transmit control information including the allocated predetermined marker to the detector;
- a receiver configured to receive detector correction information from the detector; and
- a setter configured to set operating conditions of the detector based on the received detector correction information.
- 17.** The imaging system of claim **16**, wherein the searcher searches for a virtual IP address of the detector that is not registered in the imaging system and accesses the detector by using the searched virtual IP address.
- 18.** The imaging system of claim **17**, wherein the detector profile information comprises at least one from among a real IP address, a type, and a serial number of the detector, and the registrar stores the detector profile information to an available detector list of the imaging system.
- 19.** The imaging system of claim **18**, wherein the receiver receives the detector correction information from the detector by accessing an activated real IP address of the detector, the setter sets imaging conditions for performing imaging using the detector based on the detector correction information, and the detector correction information comprises at least one from among detector step difference correction information indicating an amount of step difference correction of the detector for performing imaging and defective pixel compensation information indicating a range of defective pixel compensation of the detector for performing imaging.
- 20.** The imaging system of claim **16**, wherein the predetermined marker comprises at least one from among a character, a number, a symbol, a color, and an image.
- 21.** The imaging system of claim **16**, wherein the searcher further comprises a determinator configured to determine whether detector profile information is broadcast on a network to which the imaging system is connected, and the searcher accesses an unregistered detector corresponding to the detector profile information being broadcast on the wired or wireless network, and the profile information acquirer receives the broadcast detector profile information from the unregistered detector and stores the detector profile information in a candidate detector list, and the detector profile information comprises at least one from among a real IP address, a type, and a serial number of the unregistered detector.
- 22.** The imaging system of claim **21**, wherein the registrar stores the detector profile information on the candidate detector list to an available detector list of the imaging system.
- 23.** The imaging system of claim **22**, wherein the receiver receives detector correction information from the detector having the detector profile information stored in the available detector list, the setter sets imaging conditions for performing imaging using the detector based on the detector correction information received from the detector, and the detector correction information comprises at least one from among detector step difference correction information indicating an amount of step difference correction of the detector for performing imaging and defective pixel compensation information indicating a range of defective pixel compensation of the detector for performing imaging.
- 24.** A detector for transmitting detector correction information to an imaging system, the detector comprising: a receiver configured to receive, from the imaging system, a request to access the detector via a virtual IP address of the detector; a transmitter configured to transmit detector profile information of the detector to the imaging system in response to the request, wherein the imaging system registers the detector based on the detector profile information and transmits first control information including an allocated predetermined marker to the detector; a switch configured to switch the virtual IP address of the detector based on the first control information; and the transmitter configured to transmit the detector correction information to the imaging system.
- 25.** The detector of claim **24**, wherein the detector profile information comprises at least one from among a real IP address, a type, and a serial number of the detector, the predetermined marker comprises at least one from among a character, a number, a symbol, a color, and an image, and the detector correction information comprises at least one from among detector step difference correction information indicating an amount of step difference correction of the detector for performing imaging and defective pixel compensation information indicating a range of defective pixel compensation of the detector for performing imaging.
- 26.** The detector of claim **25**, wherein the switch deactivates the virtual IP address of the detector and activates the real IP address of the detector based on the first control information, and the detector further comprises a display configured to display a change of a state of the detector by using the allocated predetermined marker.
- 27.** The detector of claim **26**, wherein the receiver receives second control information from the imaging system, the switch deactivates the real IP address of the detector and activates the virtual IP address of the detector based on the second control information, and the display displays a change of the state of the detector by changing the allocated predetermined marker.
- 28.** A detector for transmitting detector correction information to an imaging system, the detector comprising: a broadcaster configured to broadcast detector profile information to a network to which the imaging system is connected; a receiver configured to receive, from the imaging system, first control information including an allocated predetermined marker;

a controller configured to stop the broadcasting by the detector based on the first control information; and a transmitter configured to transmit the detector correction information to the imaging system.

29. The detector of claim **28**, further comprising a display configured to display a change of a state of the detector by using the allocated predetermined marker when the broadcasting by the detector is stopped by the controller.

30. The detector of claim **29**, wherein the receiver receives second control information from the imaging system, the broadcaster starts broadcasting of detector profile information to the network based on the second control information, and the display displays a change of the state of the detector by changing the allocated predetermined marker when the broadcasting by the detector is started.

31. A non-transitory computer-readable recording medium having recorded thereon a program for executing the method of claim **1**.

32. A detector for transmitting information for setting operating conditions of the detector in an imaging system, the detector comprising:

at least one processor operable to read and operate according to instructions within a computer program; and at least one memory operable to store at least portions of said computer program for access by said processor; wherein said computer program includes algorithms to cause said processor to implement:

a transmitter configured to, in response to a request from the imaging system, transmit detector profile information to the imaging system to be registered in the imaging system;

a controller configured to, in response to registration in the imaging system, control the transmitter to transmit the information for setting operation conditions of the detector to the imaging system, the information relating to at least one from among detector step difference correction and defective pixel compensation for performing imaging by using the detector.

* * * * *