



(19) **United States**
(12) **Patent Application Publication**
MARTINEAU et al.

(10) **Pub. No.: US 2015/0157376 A1**
(43) **Pub. Date: Jun. 11, 2015**

(54) **METHOD OF PRODUCING A POROUS BONE SCREW**

Publication Classification

(71) Applicants: **The Royal Institution for the Advancement of Learning / McGill University, Montreal (CA); National Research Council of Canada, Ottawa (CA)**

(51) **Int. Cl.**
A61B 17/86 (2006.01)
B22F 3/11 (2006.01)
B22F 5/06 (2006.01)
B22F 7/00 (2006.01)
B22F 5/10 (2006.01)

(72) Inventors: **Paul A. MARTINEAU, Westmount (CA); Louis-Philippe LEFEBVRE, Boucherville (CA); Edward J. HARVEY, Westmount (CA)**

(52) **U.S. Cl.**
CPC *A61B 17/866* (2013.01); *A61B 17/863* (2013.01); *A61B 17/864* (2013.01); *B22F 7/008* (2013.01); *B22F 5/10* (2013.01); *B22F 5/06* (2013.01); *B22F 3/11* (2013.01); *A61B 2017/561* (2013.01)

(73) Assignees: **The Royal Institution for the Advancement of Learning / McGill University; National Research Council of Canada**

(57) **ABSTRACT**

(21) Appl. No.: **14/623,280**

A bone screw and method of producing the same is described. The method of producing a bone screw includes forming a one-piece headless screw body out of a rigid metallic foam that is entirely porous throughout and defines a plurality of inter-connected pores having a size of about 30 to about 500 microns in diameter. The method includes providing at least one thread on an external surface of the screw body, and forming a bore extending through an entire axial length of the screw body, the bore forming a cannula that defines an annular radial wall thickness of the screw body. The method further includes disposing the inter-connected pores throughout the radial wall thickness of the screw body such as to allow for bone in-growth through the full radial wall thickness and into the cannula.

(22) Filed: **Feb. 16, 2015**

Related U.S. Application Data

(62) Division of application No. 13/501,581, filed on Jun. 29, 2012, now Pat. No. 8,979,911, filed as application No. PCT/CA2010/001645 on Oct. 13, 2010.

(60) Provisional application No. 61/251,085, filed on Oct. 13, 2009.

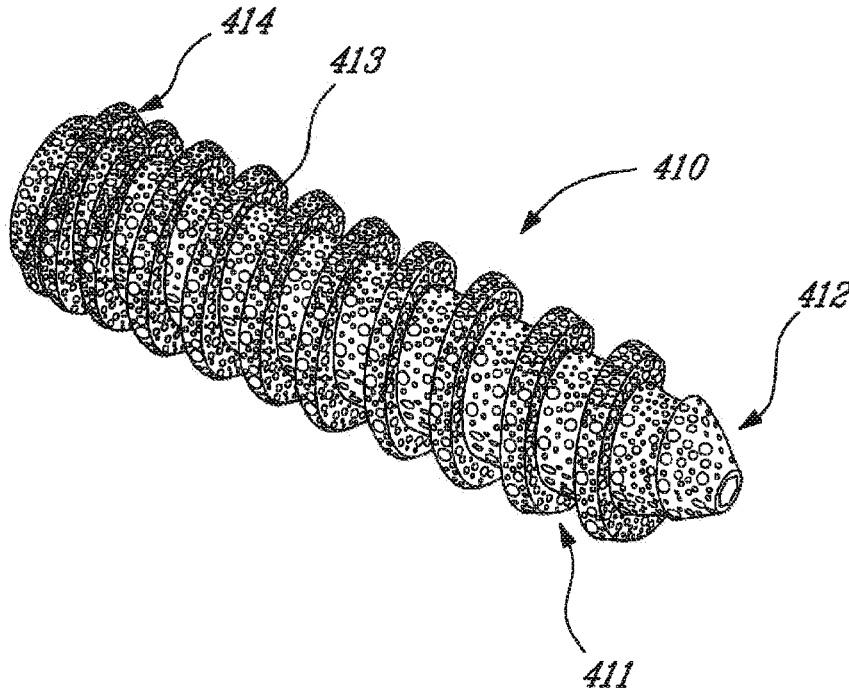

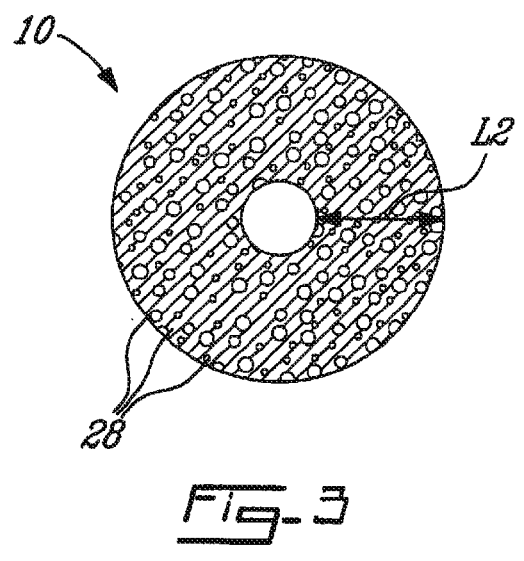
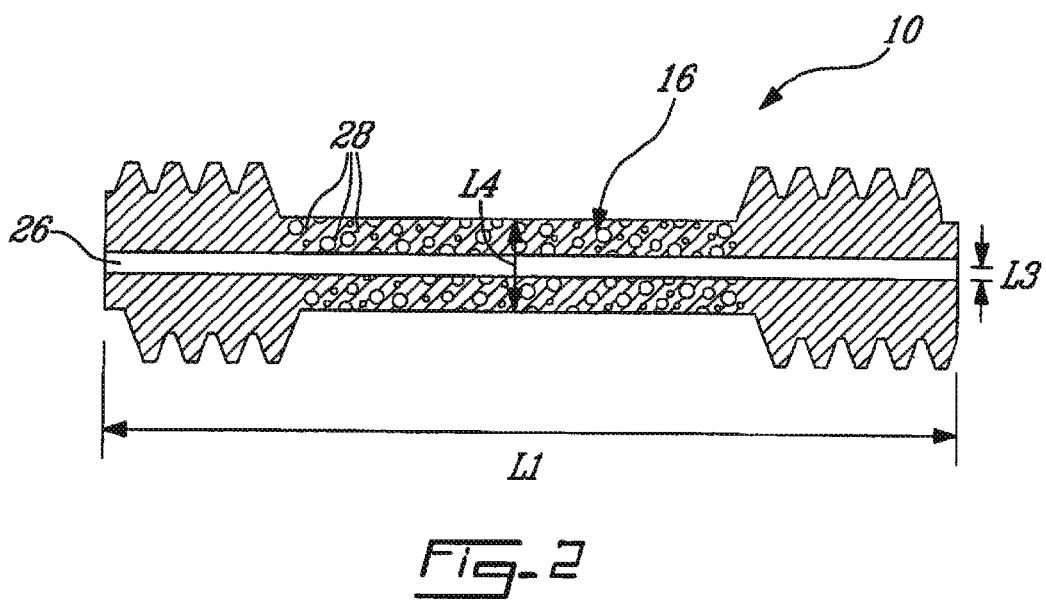
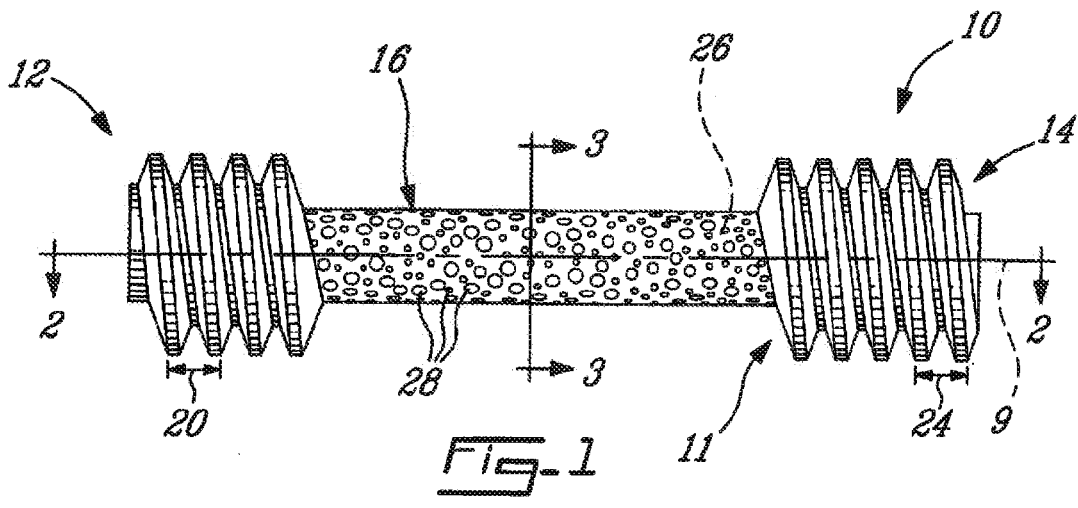

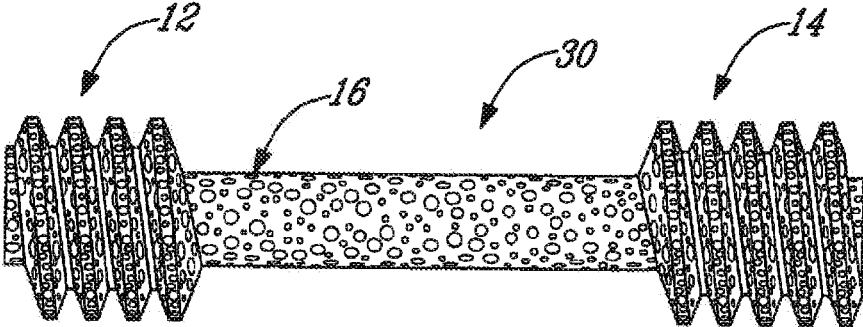

FIG. 4

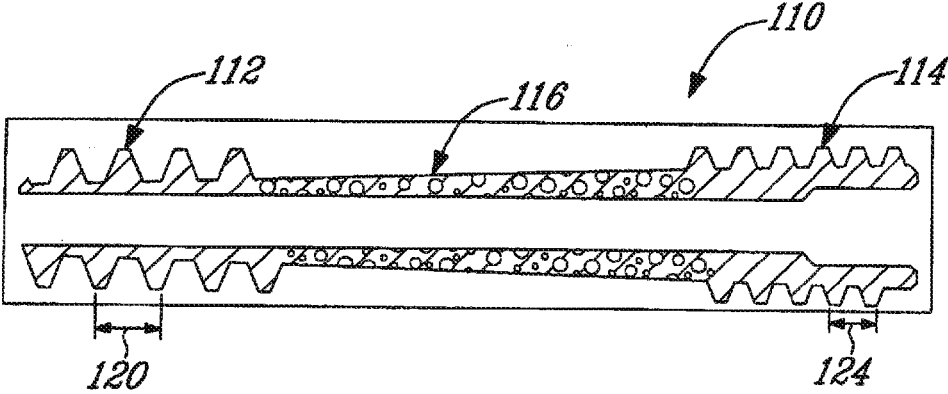

FIG. 5

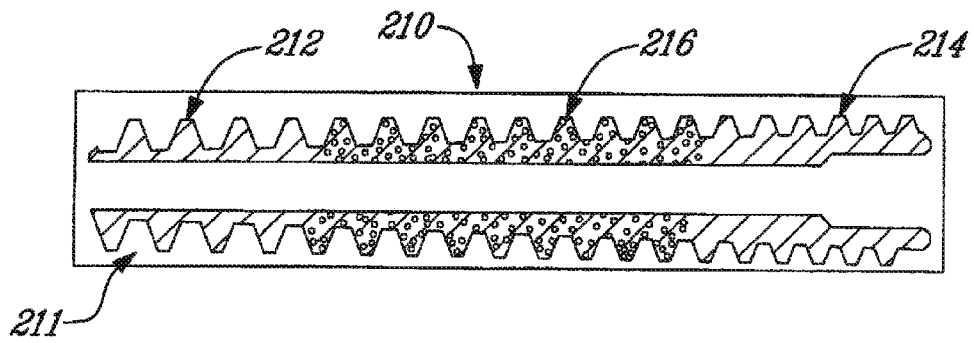

FIG-6

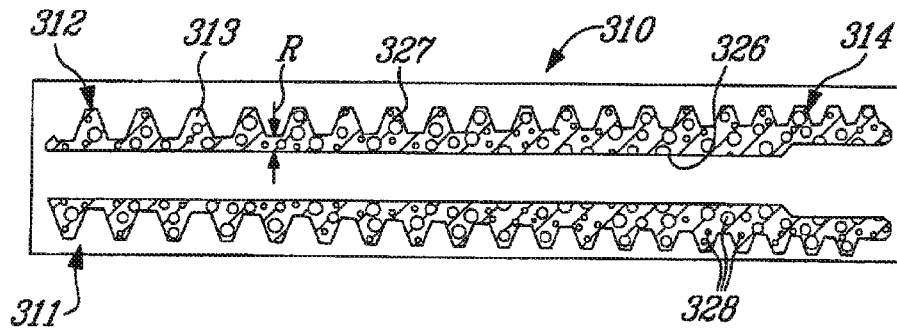

FIG-7

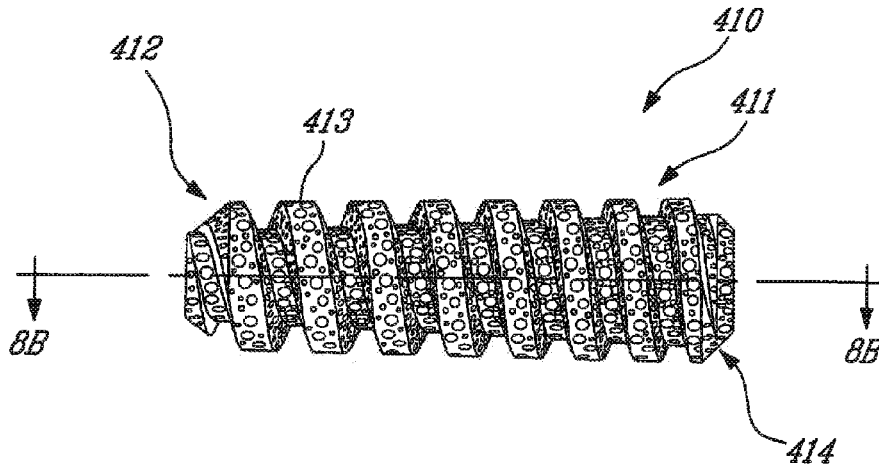

FIG. 8A

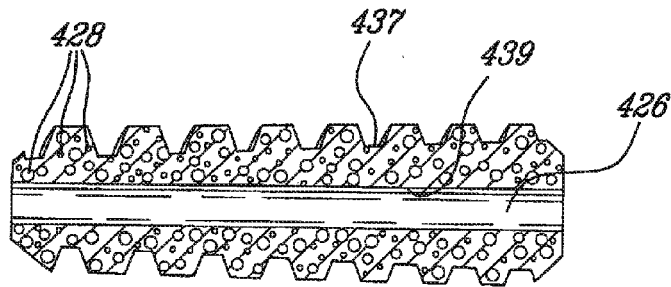

FIG. 8B

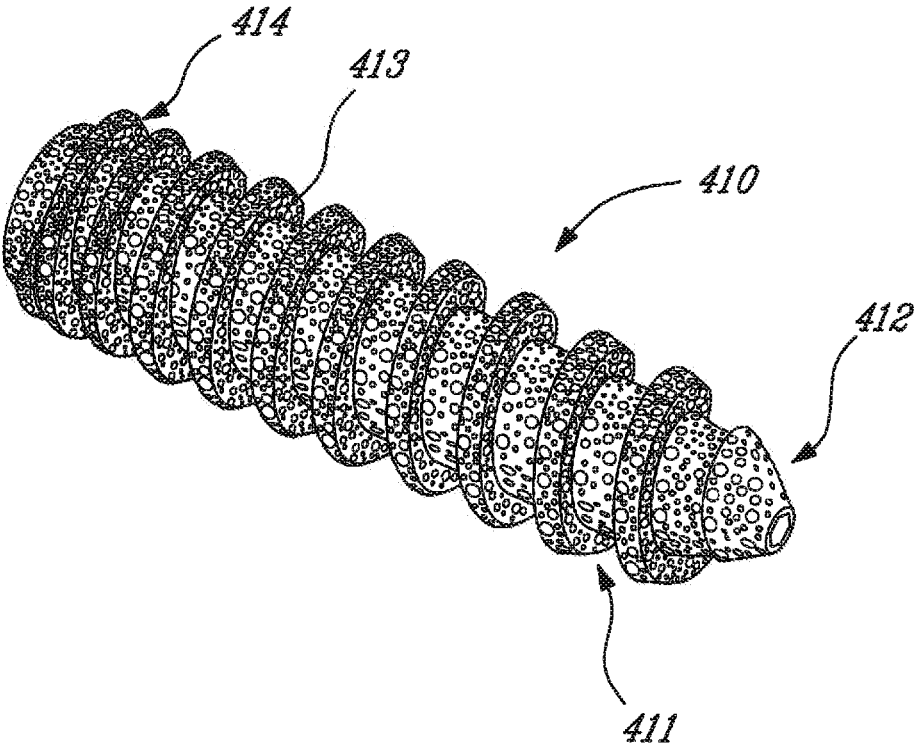

FIG. 9A

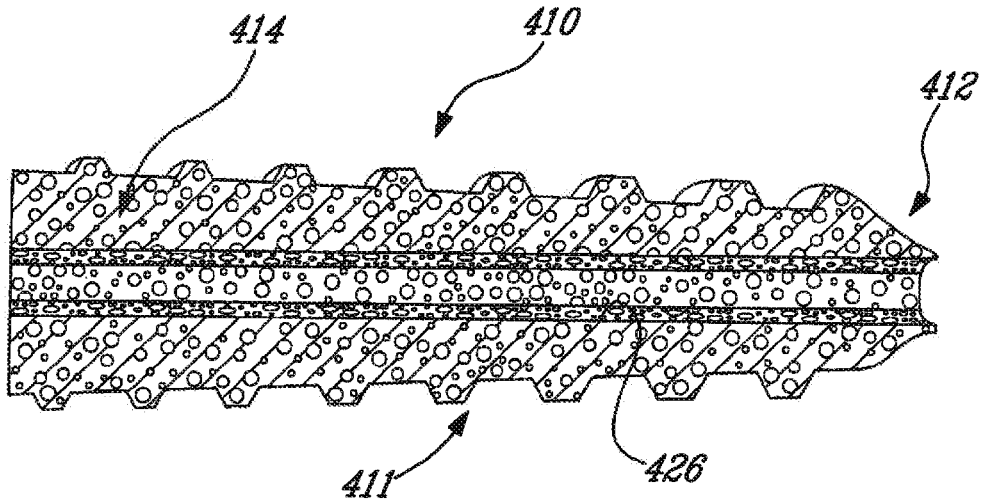

FIG. 9B

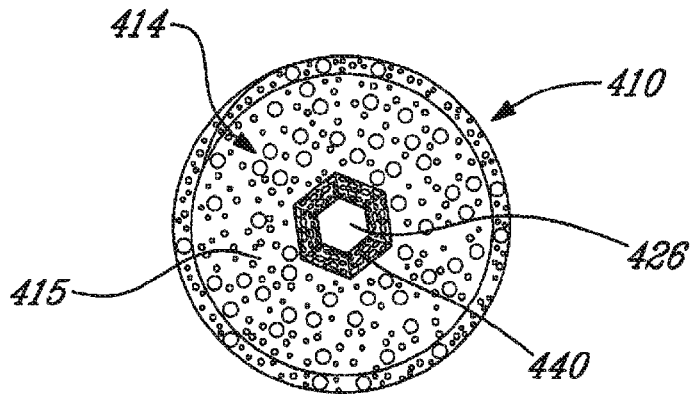

FIG. 9C

METHOD OF PRODUCING A POROUS BONE SCREW

CROSS REFERENCE TO RELATED APPLICATIONS

[0001] This application is a Divisional of U.S. patent application Ser. No. 13/501,581, filed Apr. 12, 2012, which application is a National Stage Entry of PCT Application Serial No. PCT/CA2010/001645 having an international application date of Oct. 13, 2010, which application claims priority from U.S. Provisional Application Ser. No. 61/251,085, filed Oct. 13, 2009; the disclosures of which are incorporated herein by reference.

TECHNICAL FIELD

[0002] The present disclosure relates generally to the field of bone screws, and more particularly to screws used for bone fixation.

BACKGROUND

[0003] Compression bone screws are commonly used to join together, under compression, fractured fragments of a broken bone, and are inserted during a surgical intervention to precisely locate the screw in a desired location straddling the fracture site within the bone. In general, a compression screw allows the fractured bone to increase in strength and favours prompt healing, while decreasing the risk of non-union.

[0004] The scaphoid bone, located in the wrist generally between the radius and thumb, is the mechanical link between the proximal and distal carpal rows, is one of the most commonly fractured bone in the upper extremity. Wrist fractures often involve the scaphoid bone, and primarily occur due to axial compression with the wrist in extension, inducing a flexion moment on the scaphoid and causing a fracture. As a result of the flexion moment applied, as well as its relative small size and its location, displacement and/or deformity of the scaphoid is common. In addition, the scaphoid has a limited blood supply, and thus can become avascular after a fracture, which may lead to bone necrosis.

[0005] Consequently, it is often necessary to surgically intervene to treat a fracture of the scaphoid. Such surgical intervention typically involves the insertion of a compression bone screw in the scaphoid. Although un-displaced fractures have a high rate of healing when the wrist and thumb are immobilized for a prolonged period of time, there has nonetheless been a growing trend toward surgical intervention for fixation of acute un-displaced fractures (i.e. bone fractures wherein cracks in the bone may radiate in several directions but the bone fragments do not separate) of the scaphoid. However, most scaphoid fractures are displaced, and surgical intervention is clearly warranted in these cases. Surgical intervention and rigid internal fixation have shown to decrease time of healing and risks of non-union. Surgical intervention requires precise positioning of the implant or fracture fixation structure along the central axis of the scaphoid and spanning the fracture site, rigid fixation under compression and limited disturbance of the biology of the fracture site.

[0006] Due to the small size of the scaphoid bone (typically about 22 to about 30 mm in length), many challenges exist for designing and manufacturing bone screws suitable for use in the fixation of the scaphoid. Currently, compression screws used in scaphoid fixation have been designed to be left in

place permanently, buried under articular cartilage and improvements have been made to the screw to increase compression. A commonly employed scaphoid fixation screw includes screw threads on opposed ends of the screw, each having a different pitch, such as to hold the portions of the scaphoid on opposite sides of the fracture site in compressive engagement with each other.

[0007] However, accurate placement of the screw and minimization of the space occupied by the screw such as to increase healing potential, are examples of areas where improvement is sought. Particularly when used for fracture fixation of very small bones such as the scaphoid, existing bone screws have been found to occupy valuable space where bone cannot re-grow and therefore the actual amount of bone available for healing of the fracture is often not optimized.

[0008] Accordingly, there remains a need for an improved screw for fracture fixation of bones, particularly but not necessarily small bones such as the scaphoid, which will permit both accurate placement of the screw within the bone and which optimizes the amount of bone available for healing of the fracture.

SUMMARY

[0009] Accordingly, there is provided an improved screw for bone fracture fixation.

[0010] In a very general aspect, the screw for bone fracture fixation may comprise a headless compression screw that is cannulated to allow for accurate placement within the bone and which is composed at least partially of a porous foam material that defines a plurality of inter-connected pores which permit bone ingrowth through the complete cross-section of the porous screw portion, thereby minimizing the space occupied by the metallic screw within the fractured bone.

[0011] In one particular aspect of the present invention, there is provided a bone screw comprising a one-piece screw body comprised at least partially of a rigid foam and having at least one external thread thereon, the screw body being headless, a bore extending through an axial length of the screw body to define a cannula and providing the screw body with an annular shape having a radial wall thickness, at least a central portion of the screw body being formed of said rigid foam which defines a matrix defining a plurality of interconnected pores therein having a size of about 30 to about 500 microns, the interconnected pores being disposed throughout the complete radial wall thickness of the screw body from an outer surface of the screw body to an inner surface thereof within the cannula such as to permit bone in-growth through the complete radial wall thickness of the annular screw body, the inter-connected pores and the cannula thereby respectively allowing bone in-growth through the complete radial wall thickness and the axial length of the screw body.

[0012] There is also provided, in accordance with another particular aspect of the present invention, a method of producing a bone screw comprising forming a one-piece headless screw body out of a rigid metallic foam that is entirely porous throughout and defines a plurality of inter-connected pores having a size of about 30 to about 500 microns in diameter, including providing at least one thread on an external surface of the screw body, and forming a bore extending through an entire axial length of the screw body, the bore forming a cannula that defines an annular radial wall thickness of the screw body, and disposing the interconnected pores throughout the radial wall thickness of the screw body

such as to allow for bone in-growth through the full radial wall thickness and into the cannula.

[0013] There is further provided, in accordance with another particular aspect of the present invention, a compression bone screw for fixation of the scaphoid comprising a leading end, a headless trailing end and at least one external thread therebetween, a bore extending an axial length of the screw between the leading and trailing ends, the bore being radially centered to define an annular screw body having a radial wall thickness, and the screw being formed in one-piece by a porous metallic foam, the porous metallic foam defining a plurality of inter-connected pores therein which are substantially free of material until bone in-growth through the pores occurs, the plurality of inter-connected pores being disposed through the complete radial wall thickness of the bone screw, said bone in-growth being permitted radially through the complete radial wall thickness and axially through the bore.

DESCRIPTION OF THE DRAWINGS

[0014] Reference is now made to the accompanying drawings, showing by way of illustration a preferred embodiment thereof, and in which

[0015] FIG. 1 is a top plan view of one embodiment of a compression bone screw, having a porous central portion;

[0016] FIG. 2 is a longitudinal cross-sectional view of the compression bone screw of FIG. 1, taken through line 2-2 in FIG. 1;

[0017] FIG. 3 is a cross-sectional view of the compression bone screw of FIG. 1, taken through line 3-3 in FIG. 1;

[0018] FIG. 4 is a top plan view of another embodiment of a compression bone screw, being porous throughout;

[0019] FIG. 5 is a longitudinal cross-sectional view of another embodiment of a compression bone screw, having opposed extremities with different thread pitches and a porous central portion;

[0020] FIG. 6 is a longitudinal cross-sectional view of another embodiment of a compression bone screw, being threaded along its complete length with a variable pitch and having a porous central section;

[0021] FIG. 7 is a longitudinal cross-sectional view of another embodiment of a compression bone screw that is threaded along its complete length and that is porous throughout;

[0022] FIG. 8A is a top plan view of another embodiment of a compression bone screw that is porous throughout;

[0023] FIG. 8B is a longitudinal cross-sectional view of the compression bone screw of FIG. 8A, taken through line 8B-8B in FIG. 8A;

[0024] FIG. 9A is a perspective view of an example of the compression bone screw of FIGS. 8A-8B, and is entirely composed of a porous metallic material;

[0025] FIG. 9B is a longitudinal cross-sectional view of the compression bone screw of FIG. 9A; and

[0026] FIG. 9C is an end view of the compression bone screw of FIG. 9A.

DETAILED DESCRIPTION

[0027] The bone screws described herein are intended principally for use in joining together fractured fragments of a broken bone. Although the bone screw described herein may be particularly well suited for use in the fixation of the scaphoid bone in the wrist, it may also be adapted for the

fixation of other bones, for example wherein compression across the fracture site is desirable in order to help the healing process. Additionally, although the present bone screws will be principally described with respect to their use as compression screws, it is to be understood that the present bone screws may also comprise non-compression screws, for example screws which apply tension in a bone, and/or which may be used for applications other than fracture fixation. For example, the presently described bone screws may also be employed to fasten external fixators in place to a bone, or to fasten other medical implants in place, such as rods used to stabilize the vertebral column for example.

[0028] All embodiments of the compression bone screw described herein are however at least partially porous, particularly in at least a region which is adapted to bridge the fracture line itself in the case of fracture fixation screws. As will be seen, the present bone screws may also be entirely composed of a porous material, such that the compression screw is porous throughout. By being porous through the complete thickness, or cross-sectional area, of at least the central body portion of the screw, the space occupied by the screw inside the bone is thereby limited in that the porous nature of the screw is less dense than a fully solid screw would be, thereby increasing the area available for the bone to grow into and through the screw. Accordingly, the interconnected pores defined within the foam material which forms the present bone screws extend throughout the entirety of the screw, or at least a portion thereof, thereby allowing for bone growth through at least the full radial cross-section of the screw such that the bone can gain access to the central cannula bore and subsequently grow inside the central portion of the screw. This permits the bone to fully grow through, in, and around the screw. Such a fully porous bone screw thus acts much like a scaffold or skeleton through which bone can grow, resulting in an improved healing of a fractured bone that is fixed using the present bone screws.

[0029] Accordingly, the presently described bone screws help to improve bone healing rates such as to offer a better potential for patient recovery. Other advantages of the present bone screw may also exist, such as lower probabilities of arthritis development or losing motion into the hand/wrist due to bone necrosis or failure of the fractured bone parts to fuse together. The present bone screw possesses a strength and torsional rigidity adequate to resist its surgical insertion into the bone and its removal when necessary. Given the very small nature of bone screws adapted for use in scaphoid fracture fixation and the porous nature of the present bone screw, ensuring sufficient strength and torsional rigidity is important. The bone screws described herein also have adequate flexibility/stiffness permitting it to resist flexion moment, thus increasing the strength of a fractured bone that is fixed together by the screw.

[0030] Referring now to FIGS. 1 to 3, which illustrate a headless bone screw 10 composed of an integrally formed, one-piece body 11 having a first threaded extremity 12 and an opposed second threaded extremity 14 spaced apart by a central portion 16. Although in this embodiment of the bone screw 10 this central portion 16 is un-threaded, as will be seen below the central portion of the bone screw may also be threaded, for example such that the first extremity, central portion and second extremity form a continuous external thread on the screw body. The screw body 11 may, in at least one particular embodiment, be one-piece or monolithic (i.e. integrally formed from a single piece of material), however

the properties of this monolithic body may not necessarily be uniform throughout. The body **11** generally defines an elongated shape having a longitudinal axis **9** extending through the center thereof. The screw body **11** may be substantially symmetrical to a transverse plane that is perpendicular to the longitudinal axis **9**, as seen in FIG. 3 for example wherein the central portion **16** of the body defines an annular circular profile. However, it is to be understood that this may only be strictly true for the central portion **16**, when it is not threaded. For example, if the two threaded extremities have different pitches (as seen in FIG. 5 for example) the screw body will not be symmetric to such a transverse plane.

[0031] In this particular embodiment, the first threaded extremity **12** has a first pitch **20** and the second threaded extremity **14** has a second pitch **24**. While it is to be understood that for a compression screw, these pitches must be different in order to create the compression force between the two bone portions respectively fastened by the first and second extremities, the first and second pitches **20**, **24** may also, however, be the same. This may be true, for example, in an embodiment wherein the bone screw is not a compression screw. Additionally, it is to be understood that the first and second threaded extremities as defined herein need not necessarily be separate threaded portions but may be merely the leading and trailing portions of a continuously threaded screw.

[0032] This difference in screw pitch between the two ends of the screw is better seen in FIG. 5 with reference to the bone screw **110**, which includes at least a fully porous central body portion **116** extending between the first and second threaded extremities **112**, **114**, wherein the first threaded extremity **112** that has a pitch **120** that is greater than the pitch **124** of the second threaded extremity **114**. For example, the pitch **120** of the leading screw thread **112** may be preferably selected to be greater than the pitch **124** of the trailing screw thread **114**, which generates a compressive force between the two portions of the fractured bone respectively engaged with the leading and trailing screw threads **112** and **114**.

[0033] A centrally disposed and longitudinally extending bore **26** extends throughout the axial length **L1** of the body **11**, as seen in FIG. 2, thereby forming a longitudinally extending cannula through the body **11** of the compression screw **10**. As such, the screw **10** is said to be cannulated. The cannulation of the screw **10** allows for increased ease and precision of insertion, and generally permits a less invasive surgical approach. For example, a guide wire which is received within the longitudinal bore **26** may be used to guide the screw **10** into a precise location in the bone. The longitudinal cannula bore **26** therefore has a diameter **L3** which is suitable for receiving such a guide wire therethrough, in order to optimize the ease and precision of insertion of the screw. The guide wire may have, for example, a 1 mm to 1.5 mm diameter, and therefore the diameter **L3** of the cannula **26** is, in at least this embodiment, sized just slightly greater than the 1 mm-1.5 mm guide wire to be snugly received therein.

[0034] As best seen in FIG. 3, the cannula **26** may also be radially centered within the body **11** such as to define a radial thickness **L2** which, in an exemplary embodiment, is substantially constant along at least the length of the central portion **16** of the body **11**. This radial thickness **L2** is in effect the thickness of the annular wall defined by the cannula bore **26** within the central screw body portion **16**. This radial wall thickness **L2** may be relatively thin, for example approximately 1 to 1.5 mm for example, which improves bone in

growth through the entire wall thickness and therefore through the entire central portion **16** of the screw body **11**. In the present embodiment, at least the entire central body portion **16** is completely porous, in that the pores which are defined in the central body portion extend through the complete radial wall thickness **L2**. This differs, for example, from a mere porous surface coating that may be applied to an otherwise solid screw surface.

[0035] In the embodiment shown in FIGS. 1-3, the central portion **16** of the screw body **11** is unthreaded, thereby defining the first and second threaded extremities **12**, **14**.

[0036] However, in the embodiment shown in FIG. 6, the compression bone screw may alternately be formed with threads extending the complete longitudinal length of the entire screw **210**, thereby providing a continuously threaded screw body **211**. This configuration, i.e. having an external thread extending along the full axial length of the screw, may be preferred for some applications and may also be more efficiently manufactured. In this embodiment, the central portion **216** of the screw **210** is threaded in addition to the threaded extremities **212** and **214**, or rather, the screw thread extends un-interrupted from the leading end to the trailing end of the screw. As such, the threaded extremities are merely the leading and trailing portions of the full-length screw thread. The pitch of the first and second extremities **212** and **214** may be different, and in fact the continuously threaded body **211** may have a continuously variable pitch throughout the axial (i.e. longitudinal) length of the screw **210**, as is the case for the screw **210** depicted in FIG. 6, in which the pitch gradually decreases from the leading end **212** to the trailing end **214** of the screw **210**, or in other words the threads are more spaced apart at the leading end **212** and more densely spaced at the trailing end **214**.

[0037] The threaded central body portion **216** may be formed of the same material and/or having the same properties as the central portion **16** described in further detail below, and is therefore formed of a porous material that defines pores throughout a complete thickness of the material. As will be described in further detail, this porous material may be a porous foam, and preferably may be a metallic foam for example made of titanium, stainless steel, tantalum, magnesium, ceramic, or a combination and/or alloy of any thereof. The threads themselves in this porous, threaded central portion **216** are therefore also made of this porous material. Such a fully threaded compression screw **210**, with at least the central portion **216** thereof being completely porous, may allow for more compression at the fracture site. In addition, cutting leading threads may also be provided on the leading tip (the left-hand threaded portion **212** in FIG. 6) may also be provided and can improve and simply ease of insertion of the screw.

[0038] Referring back to the bone screw **10** of FIGS. 1-3, at least the central portion **16** of the bone screw **10** is formed having pores **28** throughout the complete radial thickness **L2** of the body **11**, to allow for bone in growth through the full radial thickness **L2** (and therefore the full radial—or transverse—cross-sectional area) of the screw. As opposed to simply being a surface treatment, the fully porous nature of the material used to form at least the central portion **16** of the screw **10** is such that the pores **28** are inter-connected and disposed throughout the entire radial thickness **L2** and throughout the entire longitudinal length of at least the central portion **16** of the screw body **11**. Therefore, the porous nature of the material of the compression screws described and

depicted herein is such that it differs substantially from an overall more dense material (ex: solid metal) that simply has holes formed therein. In other words, forming a plurality of holes or perforations (formed by drilling, for example) in a dense material does not make it porous throughout, as per the definition of "porous" as used herein and as produced by the metallic foam structure of the present porous screws. The pores **28** described herein interconnect to form a plurality of interconnected voids, each in communication with the next adjacent void, and which extend substantially uniformly in all directions of the given porous section of the screw, and at least in the radial direction from the outer surface of the screw to the inner cannula bore thereof. This allows for improvements both in terms of greater bone in growth (and through-growth) into the compression screw and improved means of manufacturability. It is important that the pores **28** be hollow, i.e. voids, which are not pre-filled or otherwise obstructed with other material, as the hollow pores **28** must be clear voids in order to permit ready bone in growth through the entire bone screw. Accordingly, the interconnected pores defined within the foam material which form the bone screw extend throughout the entirety of the screw, or at least the porous portion thereof, thereby allowing for bone growth through at least the full radial cross-section of the screw such that the bone can gain access to the central cannula bore and subsequently grow inside the central portion of the screw. This permits the bone to fully grow through, in, and around the screw.

[0039] In at least one particular embodiment, the pores **28** within the central portion **16** are substantially uniformly sized and substantially uniformly spaced apart, as much as is reasonably feasible based on the production process used to form the bone screw. The material selected to form at least the central portion **16**, or alternately the entire screw **10** as will be described further below, has a porosity which is such that these bone-in growth pores **28** are defined throughout the entire thickness of bone screw.

[0040] However, it is to be understood that the pores of the rigid foam material which makes up the compression bone screws described herein do not necessarily need to be of equal size or equally, or homogeneously, spaced apart. The rigid foam, which is preferably but not necessarily composed of a metallic foam, may be comprised of a porous sintered metal made from metal powders using powder metallurgy techniques for example. This metallic foam material forms a metal matrix or network that defines inter-connected pores throughout. This interconnected porosity allows fluid flow from one side of the screw body to the other, and therefore allows for full bone in growth (in fact permits bone through-growth). This is in contrast, for example, with isolated surface pores (ex: machined or otherwise formed in a solid metallic part), which do not have connectivity between each other and with both surfaces of the component.

[0041] As discussed above, the pores **28** minimize the space occupied by the screw, thereby increasing the amount of bone which is able to grow through the bone screw **10**. This is particularly useful when the bone screw is employed in an already small bone, such as the scaphoid for example. The fully porous nature of the screw **210**, or the fully porous nature of at least the central body portion **16** of the bone screw **10**, allows for the space occupied by the screw within the bone to be also available for healing by permitting new bone in growth through the structure of the fracture-fixating bone screw **10**, thereby effectively minimizing the volume within

the bone element that is occupied by the metallic material of the screw and thus potentially increasing healing potential.

[0042] As noted in further detail below, following insertion of the bone screw **10**, a material may also be injected into the cannula **26** within the screw in order to impregnate the pores of the screw from the inner cannula outward. This material may include, for example, a bone growth promoting resin or bone protein, or a structurally reinforcing cement, etc.

[0043] Although the porous material selected to form at least the central portion **16** of the bone screw **10** may be any suitable material having the pores **28** defined throughout an entire thickness thereof, in one embodiment this porous material is a metallic foam, made for example of a titanium alloy. Although other ranges are of course possible, the pores **28** have a size (ex: diameter), in at least one particular embodiment, of about 30 to about 500 microns (i.e. μm), but preferably between 50 to 400 μm , to achieve desired levels of bone in growth and mechanical strength, and the porous material has a porosity ranging from 30% to 80%, but preferably between 40 to 70% to obtain a desired level of mechanical strength.

[0044] In one exemplary embodiment, at least the central portion **16**, but preferably the entire screw (see FIGS. 4 and 7 and related description), is composed of a biocompatible and rigid metallic foam that may preferably be, but is not necessarily, non-ferromagnetic and thus allows magnetic resonance imaging (MRI) of the bone. However, it is to be understood that a ferromagnetic metal may also be used. Examples of possible metals which may be used to form the metallic foam from which the present screws are formed include titanium, tantalum, stainless steel, TiNi, etc. Even though the material of the screw may not be magnetic per se, it is also to be understood that this non-ferromagnetic material might be composed of constituents which themselves are at least partially ferromagnetic (ex: stainless steel contains iron and nickel which are themselves ferromagnetic even if the resultant metal is not).

[0045] In order to achieve a fully porous structure for the present bone screw, it has been found particularly advantageous to form the screw from a metallic foam material. Such a foam is produced having pores of a selected size range throughout its entire structure, and formed into the desired screw shape. The metallic foam may contain titanium, magnesium, iron, tantalum or an alloy thereof such as stainless steel, Ti6Al4V or a ceramic. Although a number of methods may be used to produce such an open cell metallic foam which forms the present bone screws, in one particular embodiment the method used is as described in U.S. Pat. No. 6,660,224 which issued Dec. 9, 2003, the entire contents of which is incorporated herein by reference. Generally, a dry powder mixture containing an organic solid binder, inorganic particles and a foaming agent is heated and foamed while the organic binder is melted. The solid foamed structure is heated to eliminate the organic binder and then the remaining inorganic three-dimensional network structure is sintered into a porous rigid structure.

[0046] The configuration of the bone screw **10** as well and the specific material selected are such that the screw **10** has adequate stiffness to resist flexion moment on the scaphoid bone, as well as sufficient torsional rigidity to permit screw insertion. While the present bone screw may be made of a titanium, magnesium, tantalum, iron based alloys or ceramics, or any combination thereof, other ferromagnetic or non-ferromagnetic alloys may also be used, however preferably

non-ferromagnetic alloys are used such as to allow for post-operative MRI to proceed without interference.

[0047] Referring now back to the bone screw **10** shown in FIG. 2, the cannula **26** having a diameter **L3** traverses the entire axial (i.e. longitudinal) length **L1** of the compression screw **10**. In one embodiment, the diameter **L3** of the cannula bore **26** in the screw **10** may be about 1 mm to about 1.4 mm, in order to optimize the ease and precision of the insertion. The cannula allows for tool engagement and increased ease of insertion of the bone screw **10**. Studies point to the fact that accurate placement of the bone screw **10** within the scaphoid may be a more important variable than the amount of compression generated by the bone screw at the fracture site. Therefore, a high precision is required to install the screw and the cannula **26** permits a less invasive surgical approach. If the removal of the screw is necessary because of various medical reasons, for example infection, the screw may be removed by using the cannula **26** and a cannulated drill.

[0048] As noted above, in one particular application of the present porous bone compression screw **10** is used for fracture fixation of the scaphoid. In this embodiment, the outer diameter **L4** of the central portion **16** of the screw body **11** may be 3 or 4 mm, and the axial length **L1** of the entire screw **10** may be from 16 to 30 mm, for example produced in a number of different possible sizes within this range (ex: 16, 18, 20, 22, 24, 26, 28 and 30 mm). The length of the compression screw used for fixation would depend on the anatomical variation of the fractured bone. The relative sizes of **L1**, **L2** and **L4** may also be varied and selected as required, and will depend on the orthopaedic application of the compression screw.

[0049] FIG. 4 shows an alternate compression screw **30** which is similar in all respects to the bone screw **10** described above, however rather than having only a porous central portion, the entire headless compression screw **30** is formed of a porous material and therefore the screw **30** is porous throughout its complete length and width. Accordingly, the entire body **31** of the bone screw **30** is made of a single piece porous material and therefore both the threaded extremities as well as the un-threaded central portion are fully porous throughout. The compression screw **30** may thus be made of a single, unitary material having substantially homogeneous properties throughout.

[0050] Referring to FIG. 7, the compression bone screw **310** is similar to the screw **210** shown in FIG. 6 in that it has a continuous external thread **313** along its entire axial length and has a continuously variable pitch along the full axial length of the screw, wherein the pitch of the thread **313** at the leading end **312** of the screw is greater than the pitch of the screw thread **313** at the trailing end **314** of the screw. Additionally, the radial thickness **R** of the screw wall **327** increases gradually from the leading end **312** to the trailing end **314** of the screw **310**, and as such the radial length of each thread is greatest at the leading end **312** and smallest at the trailing end **314**, as can be readily seen in FIG. 7, as well as in FIG. 6. The compression screw **310** of FIG. 7 is completely formed of the porous, rigid foam material as per the screw **30** of FIG. 4 described above. In other words, the entire threaded body **311** of the screw **310** is made of the same fully porous foam material and thus has pores **328**, similar to those described above, through the complete axial length and complete radial width (and thus complete transverse or radial cross-sectional area) of the screw body **311**. As such, the compression bone screw **310** has a screw body **311** which defines a continuous

external thread **313** having a variable pitch and which thread extends along the full axial length of the screw body. Additionally, the entire screw **110**, including the complete screw body and the external threads themselves, is composed of a porous metallic foam material that forms a matrix defining a plurality of inter-connected pores therein that are disposed throughout the complete radial wall thickness of the screw body (and therefore completely through the full cross-sectional area of the screw body) such as to provide bone-growth communication between the external surface of the screw comprising the threads and the inner bore or cannula **326** extending through the center of the screw body **311**.

[0051] In comparison with a fully solid metal screw of the prior art, the present fully porous bone screws, such as the bone compression bone screw **310** of FIG. 7 and the compression bone screw **410** as will be described below, have been found to reduce the total volume occupied by the screw within the bone by more than 50%, which accordingly allows for significantly greater bone growth across the fracture line and thus improved healing speed and post-fracture strength. Further, in tests conducted in a fractured scaphoid, the cross-sectional area occupied by the central portion of the present porous compression bone screws was found to be only 15% of the fracture area, whereas this amount is often as much as 35% of the fracture area occupied by solid bone screws of the prior art. This results in increased bone area remaining, allowing for improved healing, when the screw is in place.

[0052] Referring now to FIGS. 8A to 8B and 9A to 9C, a compression screw **410** in accordance with another preferred embodiment is depicted. The compression screw **410** is similar to the screw **310** of FIG. 7, in that the entirety of the body **411** of the screw **410** is threaded, a single and continuous external thread **413** having a continuously variable pitch extends along the full axial length of the screw body **411**. The entire screw **410** is composed of a rigid metallic foam that is entirely porous throughout, in that the interconnected pores **428** are disposed throughout the complete axial length and the complete radial thickness of the screw body **411** (and thus through the complete transverse annularly-shaped cross-section of the screw body), such that the plurality of interconnected pores **428** provide a bone-growth communication between an outer surface **437** of the screw body **411** and an inner surface **439** thereof within the cannula bore **426** axially-extending through the center of the screw body. Accordingly, the interconnected pores **428** formed by the rigid (preferably metallic) foam material extend throughout the entirety of the complete screw **410**, thereby allowing for bone growth through the full radial cross-section of the screw such that the bone can gain access to the central cannula bore **426** and subsequently grow inside the central portion of the screw **410**. This permits the bone to fully grow through, in and around the screw **410**. The fully porous bone screw **410** thus acts much like a scaffold or skeleton through which bone can grow, resulting in an improved healing of a fractured bone that is fixed using the present bone screws.

[0053] As can be seen, the pitch of the continuous external screw thread **413** varies continuously and gradually along the full axial length of the threaded body **411**, from a greater pitch at the leading end **412** of the screw to a smaller pitch at the trailing end **414** thereof. As seen in FIG. 8B, the screw **410** includes a constant diameter cannula bore **426** extending longitudinally through the complete length of the screw body.

The screw **410** is preferably integrally formed as a monolithic, one-piece, structure that is entirely porous throughout, as noted above.

[0054] FIGS. 9A to 9C depict an example of the compression bone screw **410** as described above. The compression bone screw **410** is entirely formed, in one-piece, by a metallic foam material that is entirely porous throughout. The externally threaded body **411** of the bone screw **410** has a continuous thread **413** along its complete axial length (i.e. from leading end **412** to trailing end **414** of the screw) with a pitch that gradually and continuously decreases from the leading end **512** to the trailing end **514** thereof. As seen in FIG. 9B, the longitudinally extending cannula **526** through the center of the screw body **411** is substantially constant in diameter along the axial length of the screw, thereby defining a continuously increasing radial wall thickness from the leading to the trailing end of the screw. As best seen in FIG. 9C, the trailing end **414** includes a hexagonal shaped opening **440** in the flat end **415** of the screw which communicates with the cannula **426** of the screw body. This hexagonal shaped opening **440** provides a mounting point for receiving a driving device, such as a screwdriver, that can be used to rotatably drive the screw during the insertion thereof into the bone.

[0055] Although the compression bone screw **410** may be formed such as to have substantially constant properties throughout, it is to be understood that the manufacturing process used to create the metallic foam screw **410** may result in slight non-homogeneities in the screw. However, in an alternate configuration, the screw **410** may also be provided with intentionally differing properties in different regions thereof. For example, the central portion of the screw, which is most likely to extend across the actual fracture line in the bone, may be provided with more pores or a more porous structure (i.e. less dense) than the opposed ends. It is to be understood, however, that the annular walls of the screw body must nonetheless maintain a minimum torsional strength such as to permit the screw to be rotationally driven into, and out of when necessary, the bone.

[0056] A coating may also be applied onto any one of the above-described the bone screws in order to assist and/or enhance the bone in growth therethrough. This coating may be, for example, hydroxyapatite (HA) or another suitable biocompatible bone growth promoting material. Additionally, the bone screws may be coated with a pharmaceutical product to help ease healing of the bone following surgery. Such a bone-growth promoting product or a pharmaceutically active product which eases healing of a bone fracture may also be inserted directly into the bone screws, as described in further detail below.

[0057] The cannula of any of the bone screws described herein may further contain, in another alternate embodiment, a material introduced therein which may help induce bone growth. This may include, for example, a bone protein. This bone-growth promoting product may be easier “pre-loaded” into the cannula of the bone screw prior to its insertion into the bone, or may alternately be injected into the cannula once the screw is in place within the bone. Further still, a plug or rod may be introduced into the cannula bore **26**, either before or after insertion of the screw in place within the bone, in order to increase the structural integrity of the screw **10** or in order to further assist with bone in growth through the entire diameter of the screw (or at least the central portion **16** thereof). For example, a plug or narrow rod of titanium foam can be inserted down into the cannula bore **26** in the bone screw **10**.

This permits the cannula **26** to be used in order to permit an accurate insertion of the bone screw, and then the cannula **26** can be filled with a porous foam rod which in effect renders the entire cross-section of the screw body porous in nature. In yet another alternate embodiment, the cannula bore **26** may be filled with a bone cement or another hardenable material which acts to reinforce the screw **10** and improve the fixation of the bone fracture.

[0058] It is to be understood that the material(s) chosen for the presently described compression bone screws is such that they are fully biocompatible and suitable for use in connection with fracture fixation within humans and animals.

[0059] The term “rigid” as used herein with reference to the foam material from which the present compression screws are formed is understood to mean structurally self-supporting and being sufficient strong (ex: has sufficient torsional stiffness) to withstand insertion into (and removal from) a bone element using an appropriate driving device (ex: screwdriver, powered or manual) without bending or substantially deflecting or compressing, etc.

[0060] The above description is meant to be exemplary only, and one skilled in the art will recognize that changes may be made to the embodiments described without departing from the scope of the invention disclosed.

[0061] For example, the outer diameter of the bone screw may be non-constant through the length of the bone screw, and therefore the radial side wall thickness and/or the depth of the outer threads may vary over the length of the screw. While the inner cannula bore diameter may preferably be substantially constant, this too may vary along a length of the screw. Additionally, although the entire central portion of the bone screw is described as being made of the defined porous material, it is to be understood that less than the entire length of this central portion may be porous. For example, only a predetermined portion, likely that which will overlap the fracture site, of the central body portion (whether threaded or not) may be made porous while the remainder of the central portion and in fact a remainder of the entire screw may be a solid material (i.e. substantially free of pores). Still other modifications which fall within the scope of the present invention will be apparent to those skilled in the art, in light of a review of this disclosure, and such modifications are intended to fall within the appended claims.

What is claimed:

1. A method of producing a bone screw comprising forming a one-piece headless screw body out of a rigid metallic foam that is entirely porous throughout and defines a plurality of inter-connected pores having a size of about 30 to about 500 microns in diameter, including providing at least one thread on an external surface of the screw body, and forming a bore extending through an entire axial length of the screw body, the bore forming a cannula that defines an annular radial wall thickness of the screw body, and disposing the inter-connected pores throughout the radial wall thickness of the screw body such as to allow for bone in-growth through the full radial wall thickness and into the cannula.
2. The method as defined in claim 1, further comprising forming the rigid metallic foam as a porous sintered metal made from metal powders using powder metallurgy.
3. The method as defined in claim 2, further comprising forming the rigid metallic foam using at least one of titanium, tantalum, magnesium, iron or an alloy of any one or more thereof.

4. The method as defined in claim 1, further comprising covering at least the external surface of the screw body, including said thread, with at least one of a bone growth promoting material, a pharmaceutical healing agent and a structurally reinforcing cement.

5. The method as defined in claim 1, further comprising filling the cannula with at least one of a bone growth promoting material, a pharmaceutical healing agent and a structurally reinforcing cement.

6. The method as defined in claim 1, further comprising forming the thread having a first pitch at a leading end of the screw and a second pitch at a trailing end of the screw, the first pitch being greater than the second pitch such as to create a compression bone screw.

7. The method as defined in claim 6, further comprising forming the thread with a continuously decreasing pitch along the screw body from the leading end to the trailing end.

8. The method as defined in claim 1, further comprising forming a continuously threaded screw body between leading and trailing ends of the bone screw.

* * * * *