



(19) **United States**

(12) **Patent Application Publication**
Tanaka et al.

(10) **Pub. No.: US 2016/0156113 A1**
(43) **Pub. Date: Jun. 2, 2016**

(54) **CONNECTION STRUCTURE OF ELECTRIC WIRE AND TERMINAL, AND MANUFACTURING METHOD THEREOF**

Publication Classification

(71) Applicant: **YAZAKI CORPORATION**, Tokyo (JP)

(51) **Int. Cl.**
H01R 4/72 (2006.01)
H01R 4/18 (2006.01)

(72) Inventors: **Shinya Tanaka**, Shizuoka (JP); **Hisashi Hanazaki**, Shizuoka (JP); **Hironori Kitagawa**, Shizuoka (JP)

(52) **U.S. Cl.**
CPC ... *H01R 4/72* (2013.01); *H01R 4/18* (2013.01)

(21) Appl. No.: **15/018,572**

(57) **ABSTRACT**

(22) Filed: **Feb. 8, 2016**

A connection structure of an electric wire and a terminal includes the electric wire, the terminal, and a seal part. The electric wire has an insulating coated part in which a conductor part is covered with an insulating material, and a conductor exposed part in which the insulating material of an end of the electric wire is removed. The terminal includes a first crimp part crimped to the insulating coated part, and a second crimp part crimped to the conductor exposed part. The seal part is made of thermoplastic elastomer and covers a surface including the first crimp part and the insulating coated part of a side extending from said first crimp part toward a direction opposite to the end of the electric wire and a surface of the second crimp part in an extension direction of the electric wire.

Related U.S. Application Data

(62) Division of application No. 13/895,095, filed on May 15, 2013.

Foreign Application Priority Data

Nov. 26, 2010 (JP) 2010-263601
Jan. 20, 2011 (JP) 2011-009438

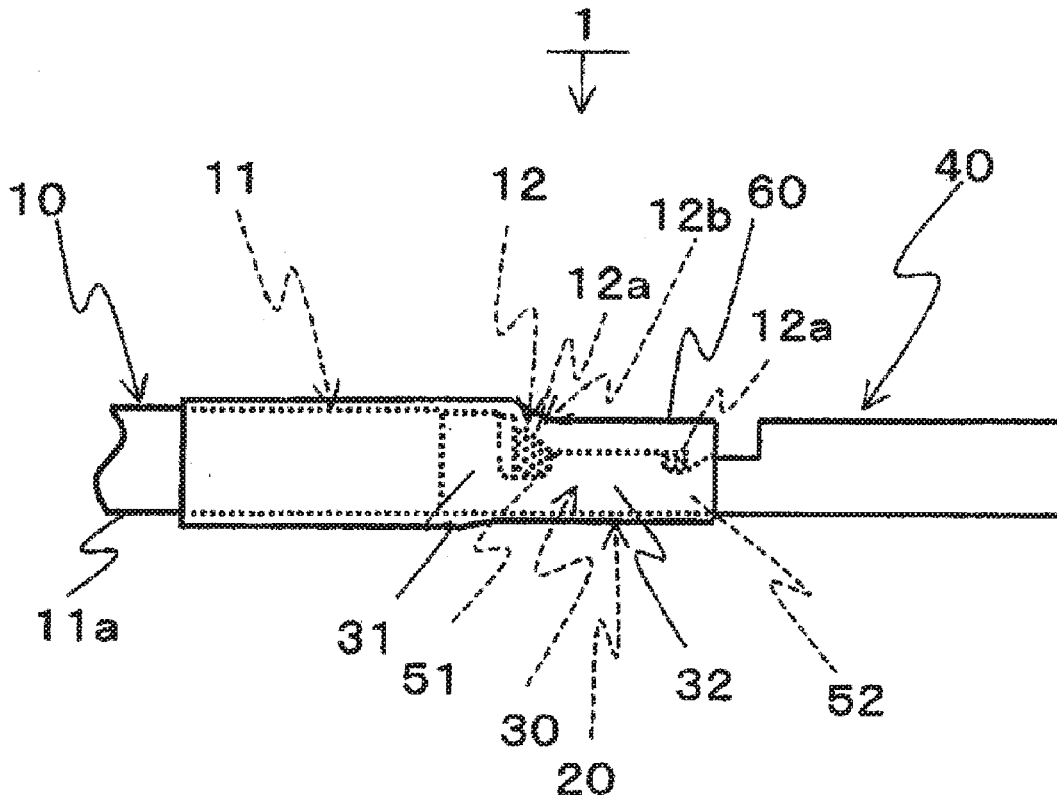

FIG. 1

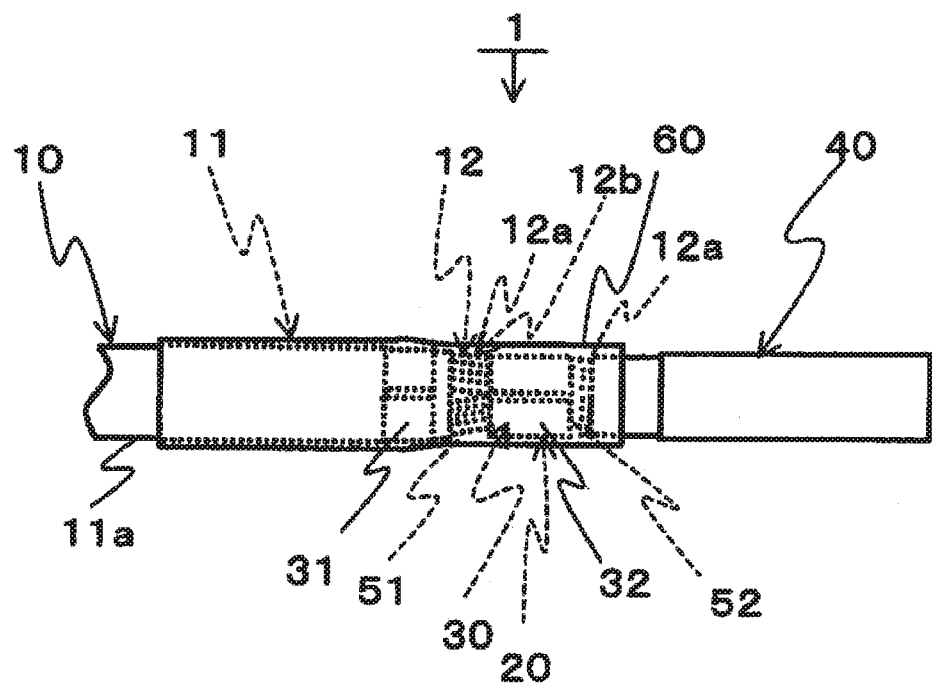

FIG. 2

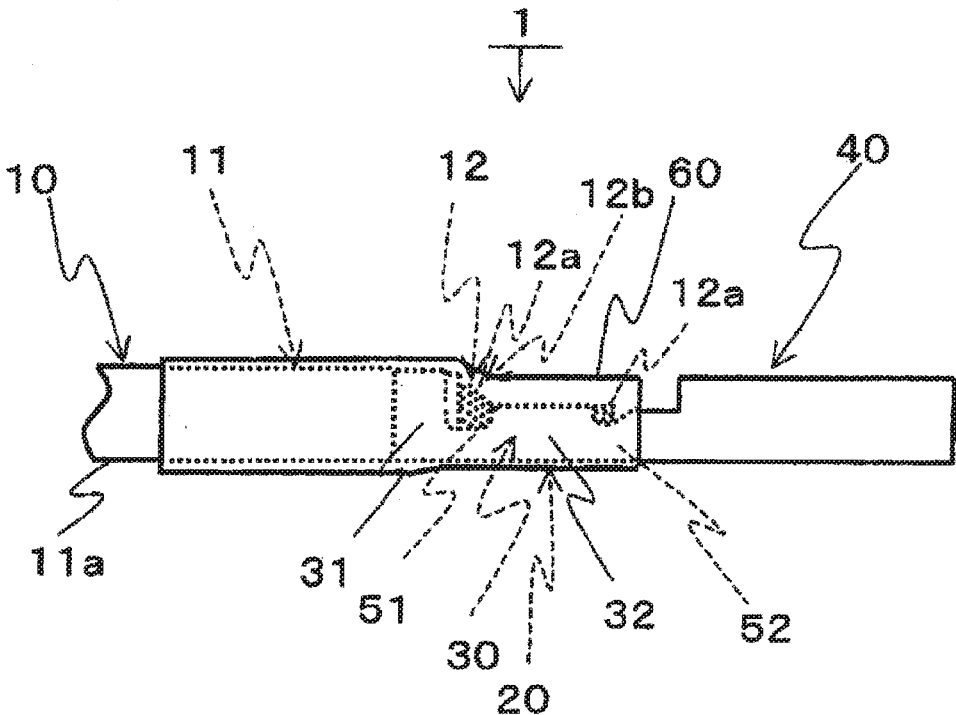

FIG. 3A

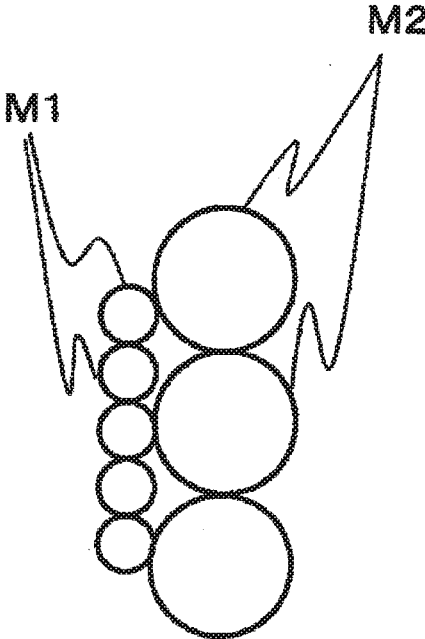

FIG. 3B

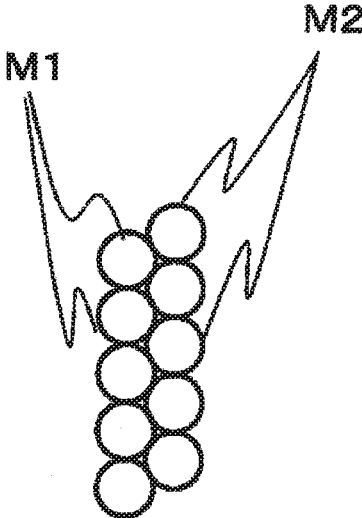

FIG. 4

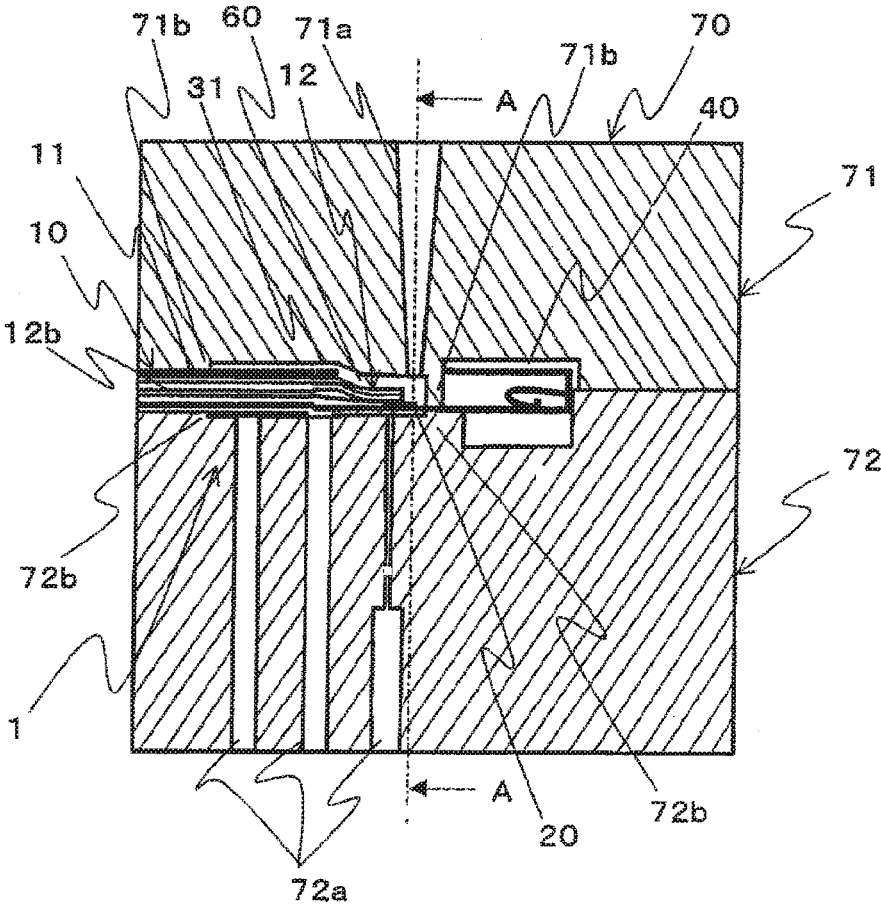

FIG. 5

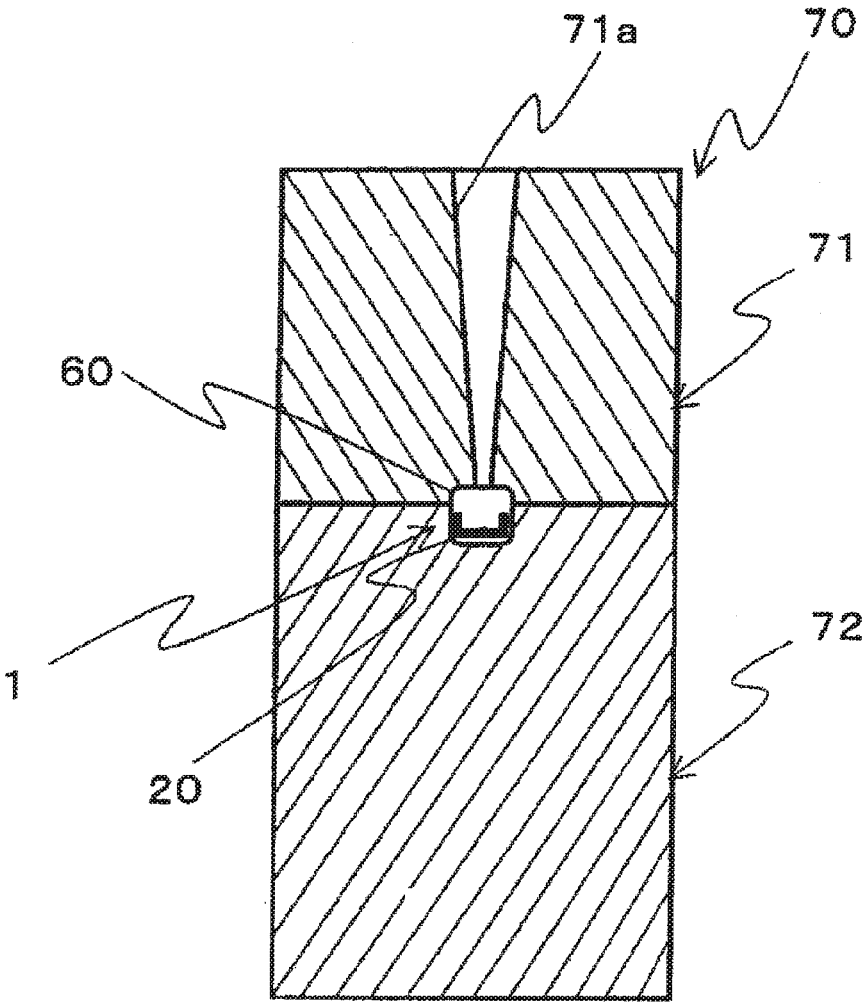

FIG. 6A

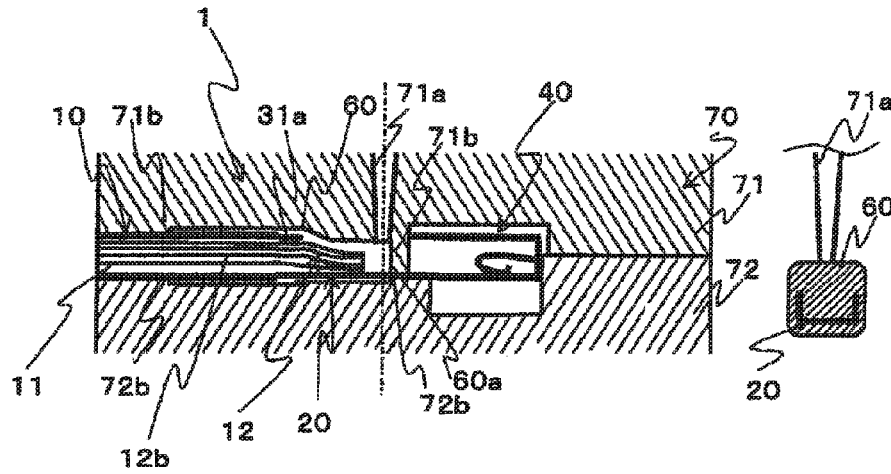

FIG. 6B

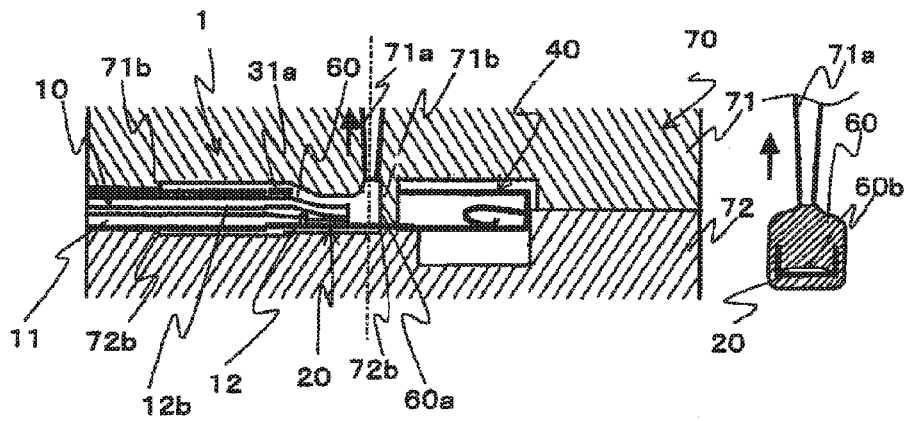

FIG. 7

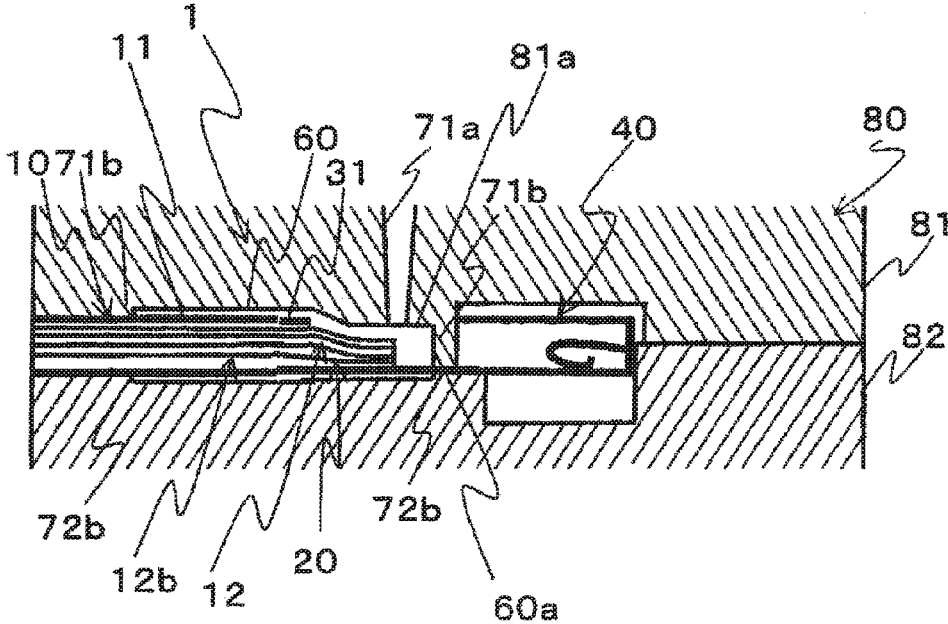

FIG. 8

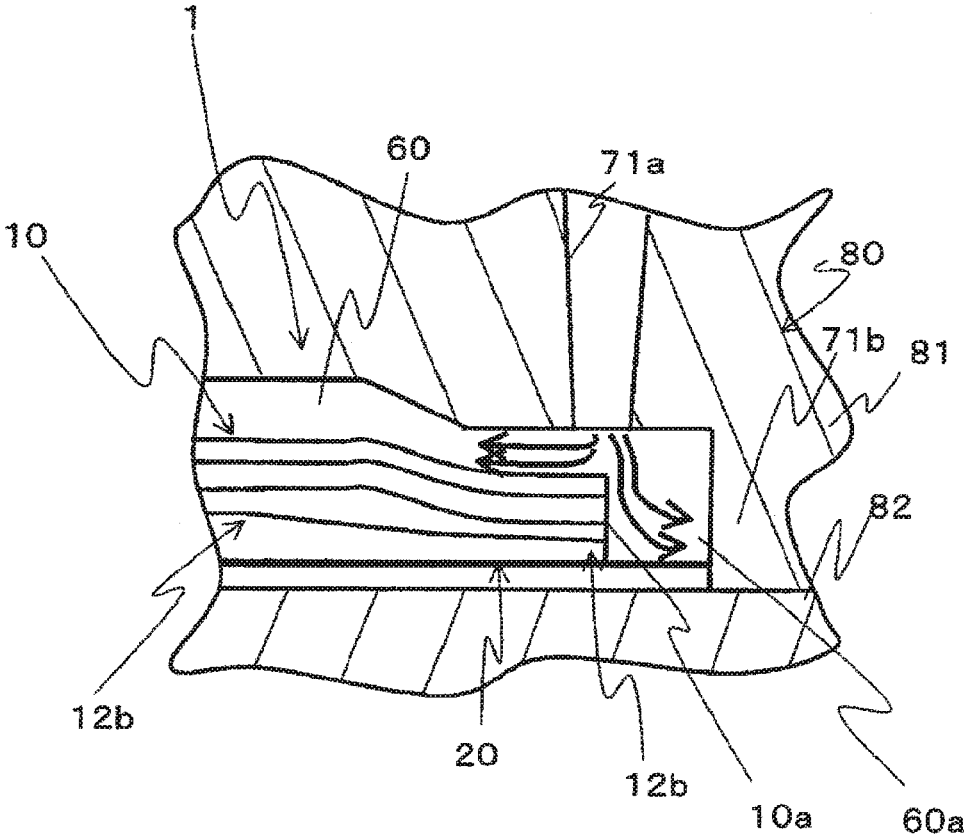

FIG. 9

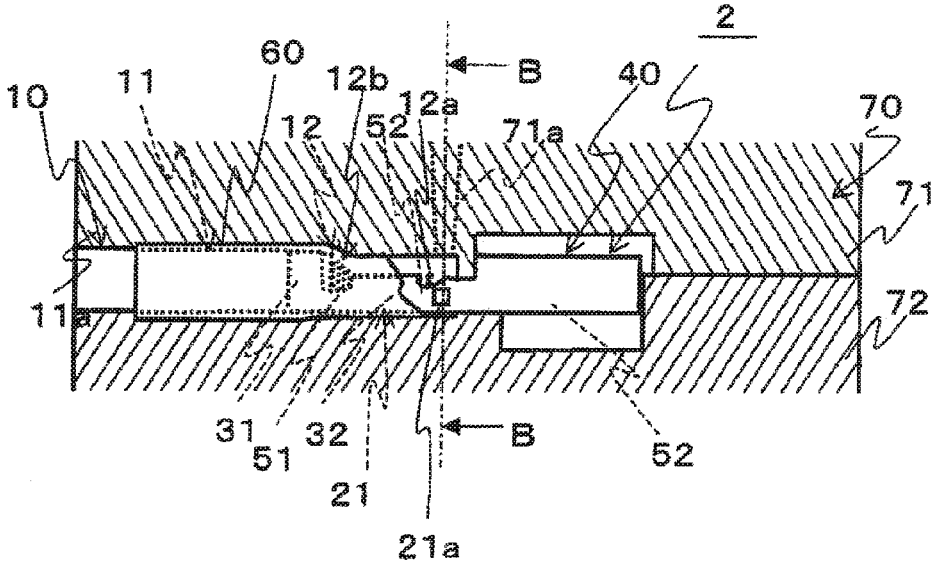

FIG. 10

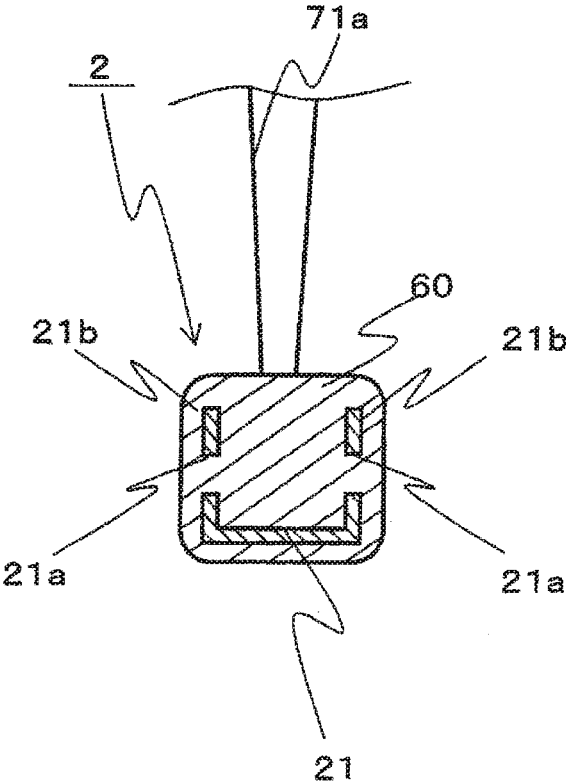

FIG. 11

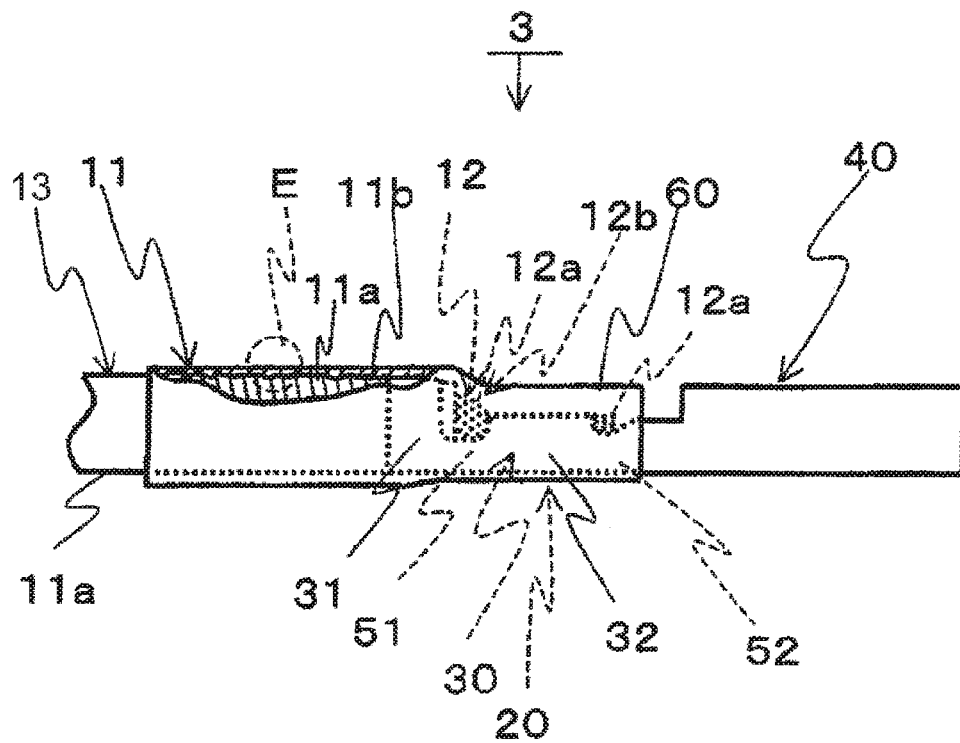

FIG. 12

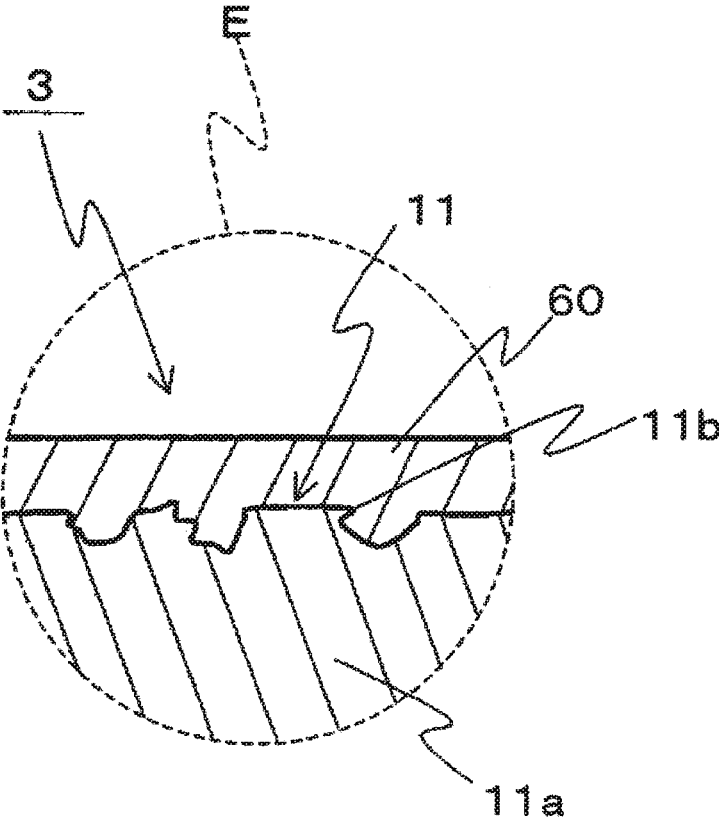

FIG. 13

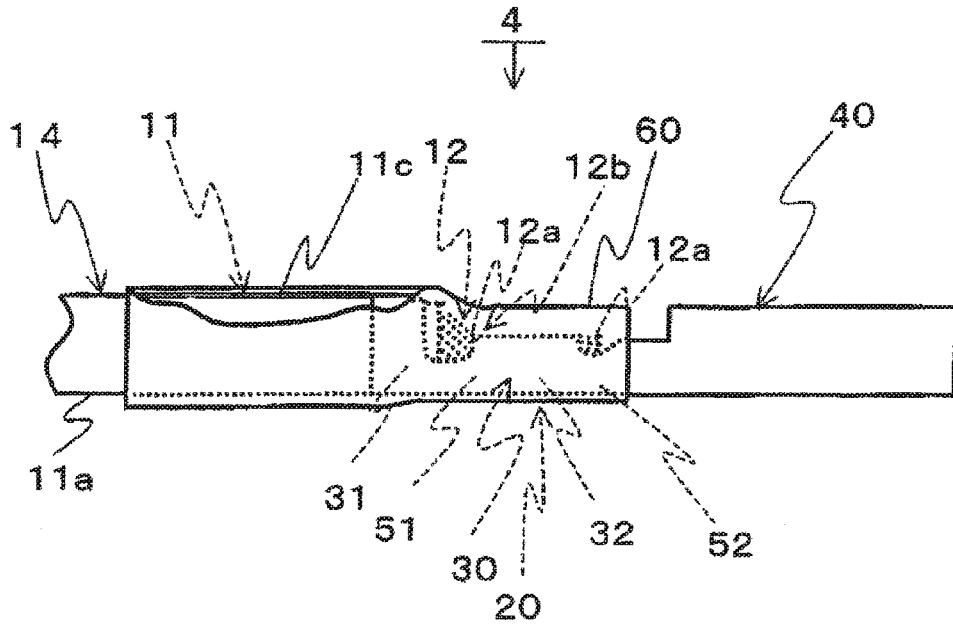

FIG. 14

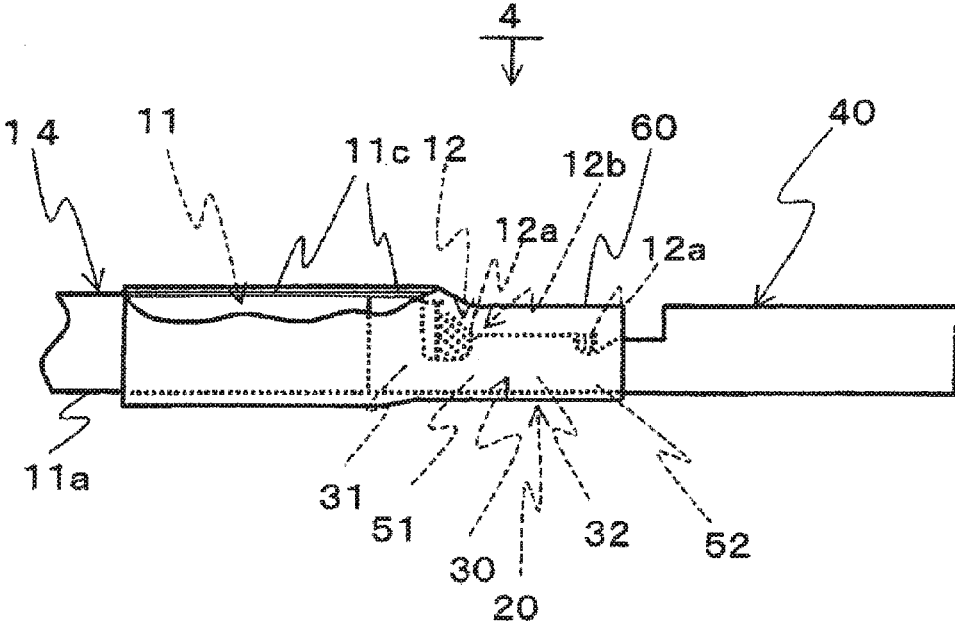

FIG. 15

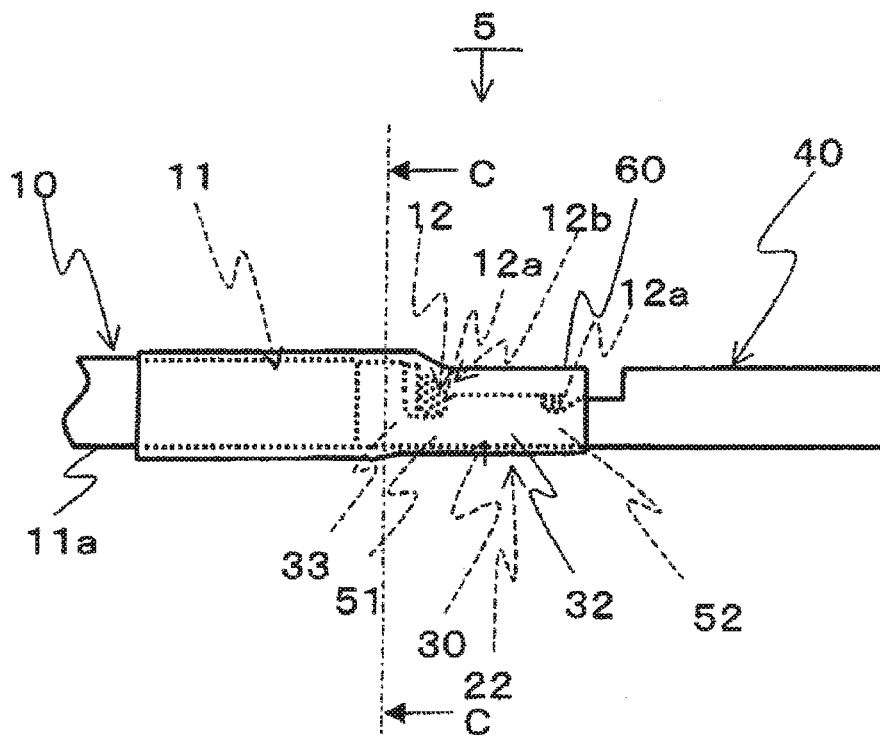

FIG. 16

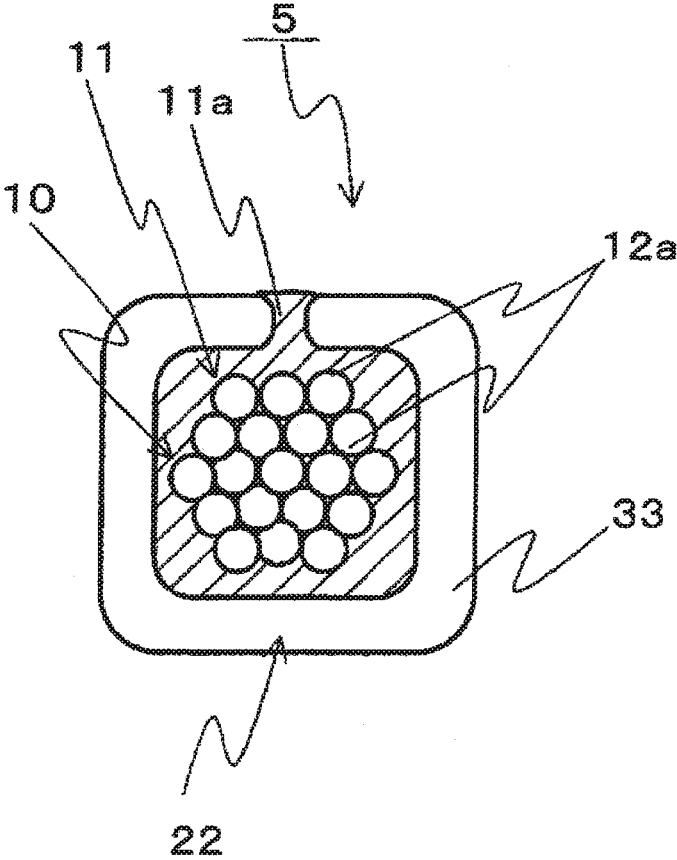

FIG. 17

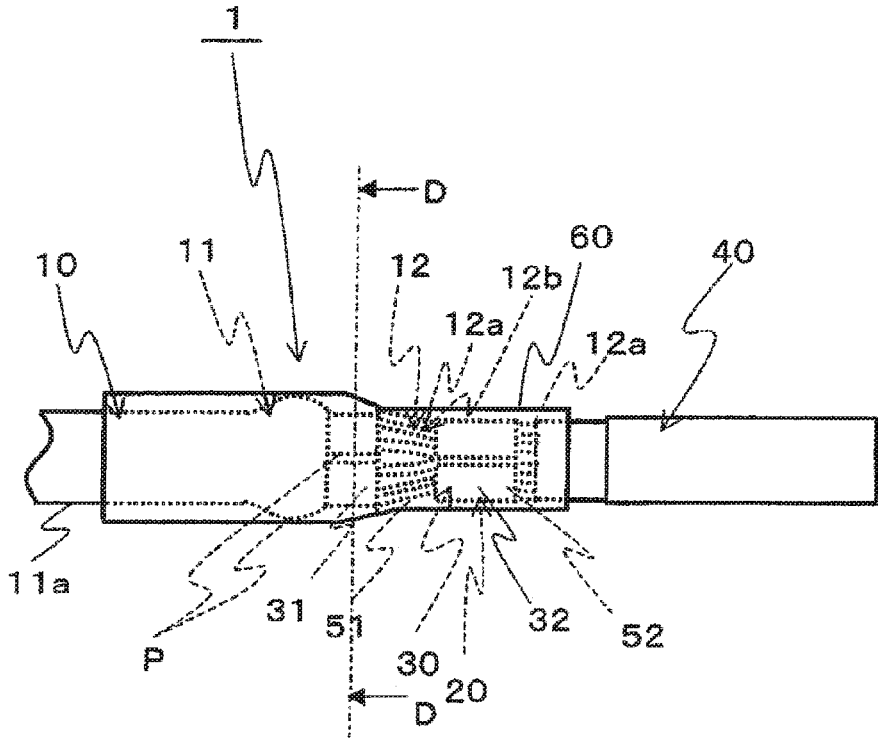

FIG. 18

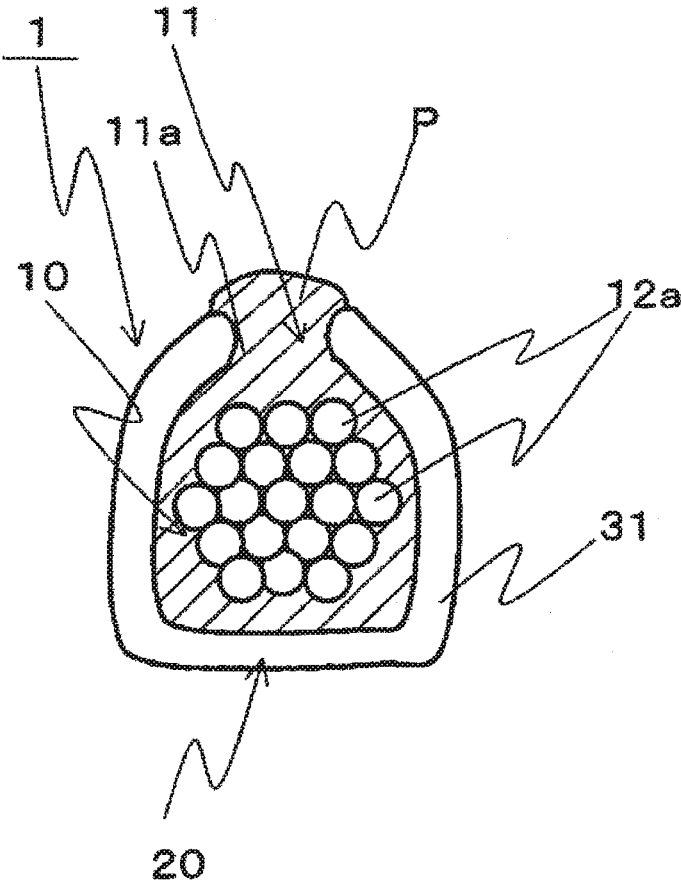

FIG. 19

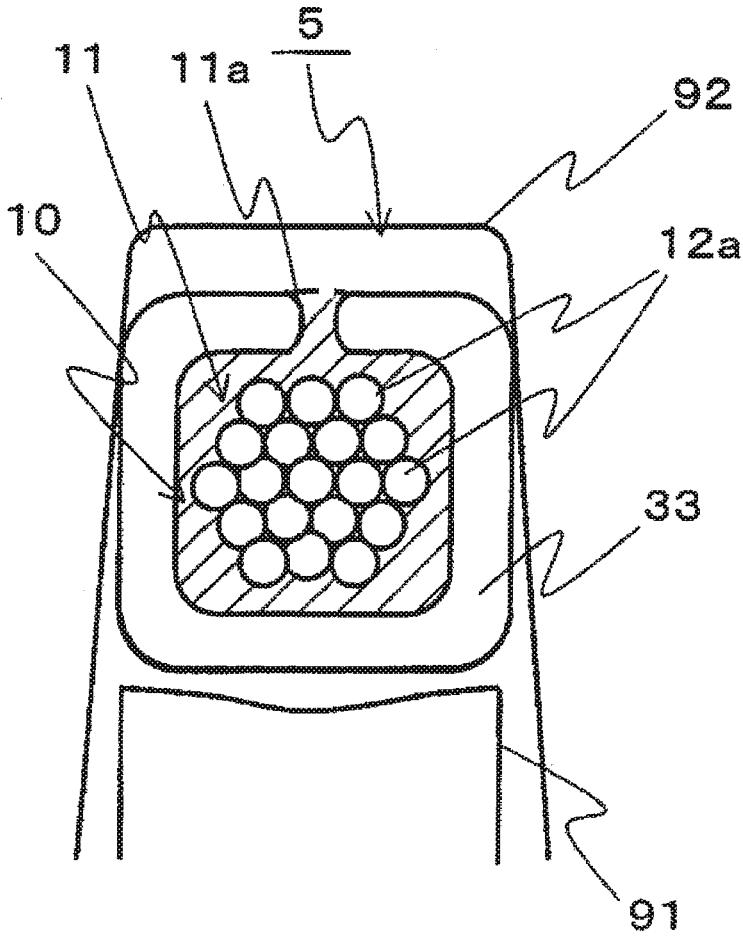

FIG. 20

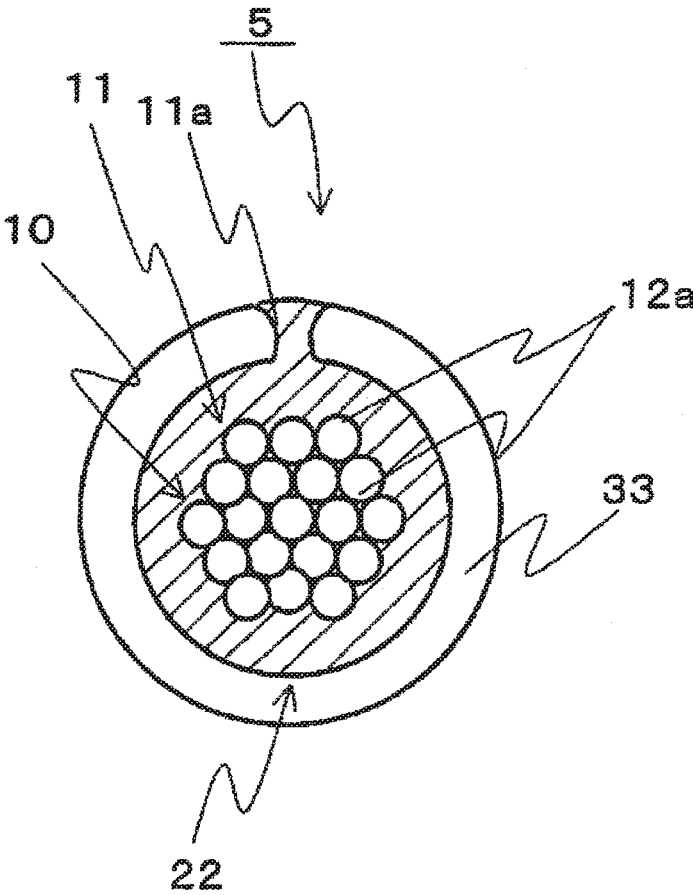

FIG. 21

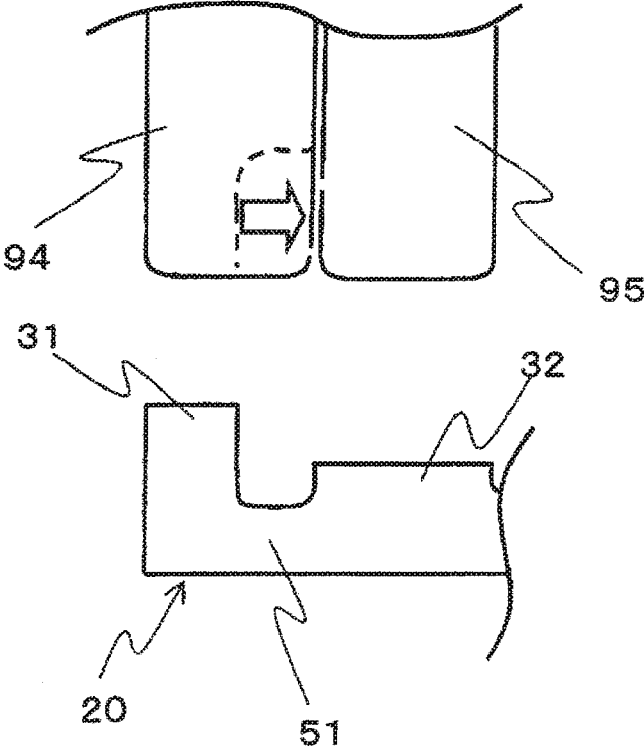

FIG. 22

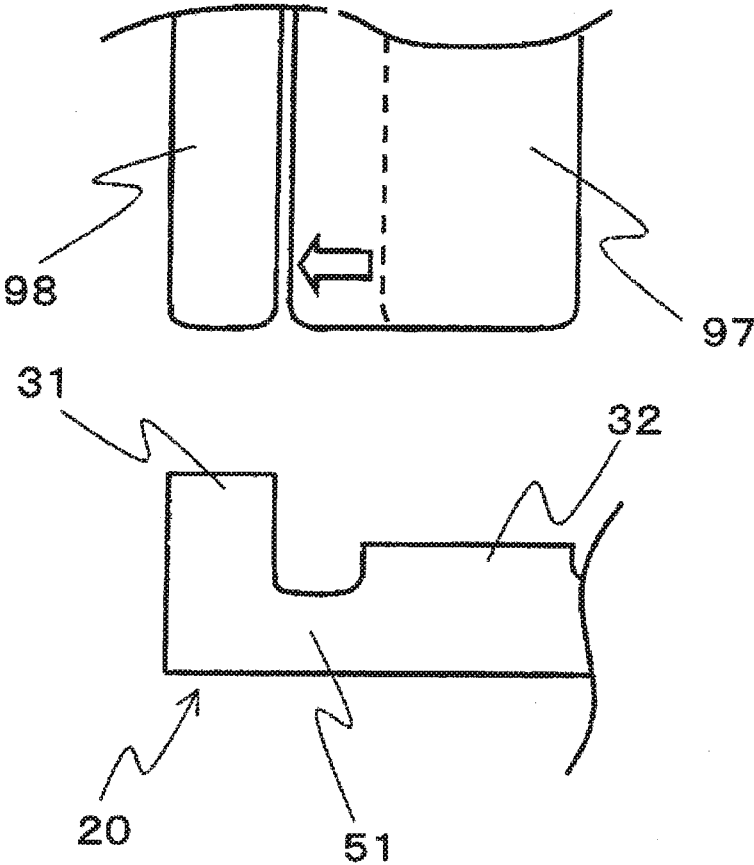

FIG. 23

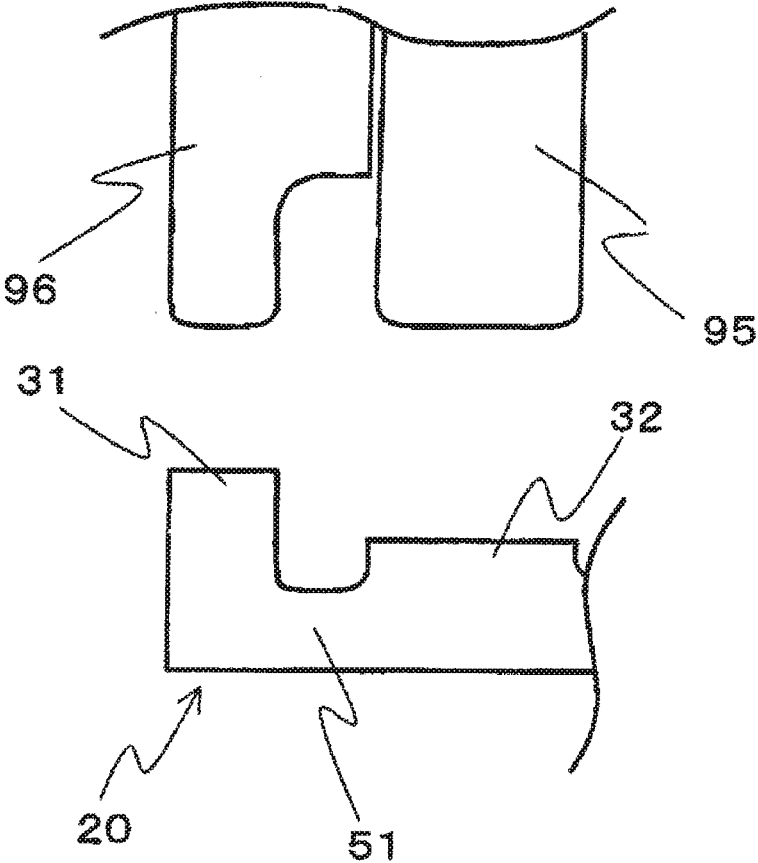

FIG. 24

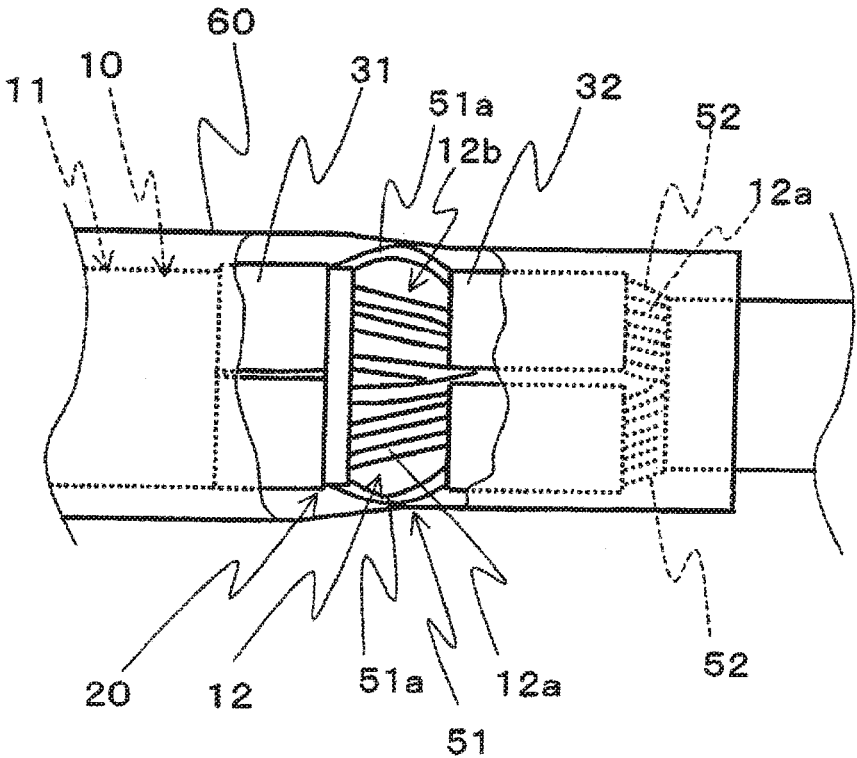
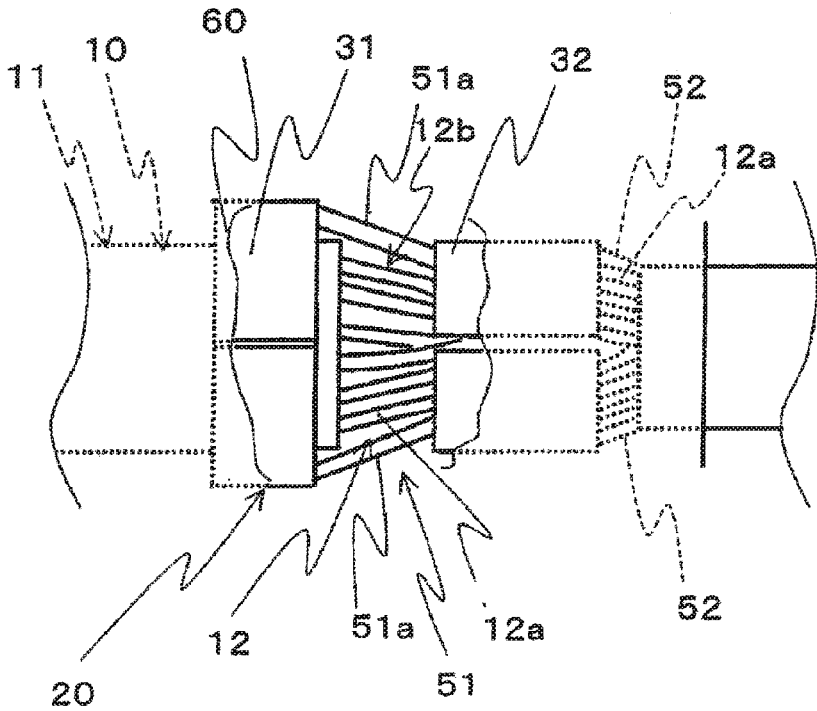

FIG. 25



**CONNECTION STRUCTURE OF ELECTRIC
WIRE AND TERMINAL, AND
MANUFACTURING METHOD THEREOF**

CROSS REFERENCE TO RELATED
APPLICATION

[0001] This application is a divisional application claiming the priority benefit under 35 U.S.C. §120 to co-pending and commonly assigned U.S. patent application Ser. No. 13/895,095 filed on May 15, 2013, which claims the priority benefit under 35 U.S.C §119 of Japanese Patent Application No. 2010-263601 filed on Nov. 26, 2010, and 2011-009438 filed on Jan. 20, 2011, the contents of which are incorporated herein by reference.

BACKGROUND OF THE INVENTION

[0002] 1. Technical Field

[0003] The present invention relates to a connection structure of an electric wire and a terminal, and particularly to a connection structure of an electric wire having a core wire made of aluminum and a terminal made of metal different from that of the core wire, and a manufacturing method of the structure of connection.

[0004] 2. Background Art

[0005] A signal line or a power line in which an electric wire having a core wire made of a copper material is connected to a terminal made of a copper material has conventionally been used in an automobile, a home appliance, etc.

[0006] On the other hand, the automobile industry has a problem important to improve fuel efficiency by reducing vehicle weight out of consideration for environment. Because of this, an electric wire using aluminum more lightweight than copper as a material of a core wire receives attention.

[0007] However, aluminum tends to corrode in the presence of water and copper ions, so that there was a problem of tending to corrode when water enters the portion of connection between the core wire made of aluminum and a terminal made of copper.

[0008] Hence, a connection structure of an electric wire and a terminal, in which the structure is made waterproof and corrosion is prevented by covering the portion of connection between the core wire made of aluminum and the terminal made of copper with resin, is proposed (for example, see Patent Literature 1).

[0009] The connection structure of the electric wire and the terminal described in this Patent Literature 1 includes the terminal, a conductor which is made of metal different from that of the terminal and is connected to the terminal by crimping a conductor part and an insulating coated part, and a resin layer applied so as to seal and cover at least a part of the terminal and the conductor part exposed from the terminal.

CITATION LIST

[0010] Patent Literature 1: JP-A-2010-108829

[0011] However, in the connection structure of the electric wire and the terminal described in this Patent Literature 1, the resin is locally formed, so that there was a problem that when an external force is applied, the portion of adhesion between the resin and the terminal tends to peel and water enters the peeling portion and consequently corrosion-proof properties of the connection structure of the electric wire and the terminal reduce.

[0012] The invention has been implemented in view of the above, and an object of the invention is to provide a connection structure of an electric wire and a terminal capable of improving corrosion-proof properties.

SUMMARY OF THE INVENTION

[0013] In order to solve the problems described above and achieve the object, a connection structure of an electric wire and a terminal according to the first aspect of the invention has the electric wire having an insulating coated part in which a conductor part is covered with an insulating material, and a conductor exposed part in which the insulating material of an end of the electric wire is removed, the terminal including a first crimp part crimped to the insulating coated part, and a second crimp part crimped to the conductor exposed part, and a seal part which is made of thermoplastic elastomer and covers a surface including the first crimp part and the insulating coated part of a side extending from the first crimp part toward a direction opposite to the end of the electric wire and a surface of the second crimp part in an extension direction of the electric wire, such that an outer periphery of the electric wire is seamlessly covered with the seal part when viewed in a cross section orthogonal to the extension direction of the electric wire.

[0014] Also, in the invention described above, a connection structure of an electric wire and a terminal according to the second aspect of the invention is characterized in that the terminal has a box shape and has a notched part in which a notch is formed in an upper part between the first crimp part and the second crimp part, and an outer periphery of the electric wire in the notched part is seamlessly covered with the seal part when viewed in a cross section orthogonal to the extension direction of the electric wire.

[0015] Also, in the invention described above, a connection structure of an electric wire and a terminal according to the third aspect of the invention is characterized in that the terminal has a box shape and an opening is formed in a side wall covered with the seal part.

[0016] Also, in the invention described above, a connection structure of an electric wire and a terminal according to the fourth aspect of the invention is characterized in that a surface of the insulating coated part of a side extending from the first crimp part toward a direction opposite to an end of the electric wire has an uneven shape by roughening treatment.

[0017] Also, in the invention described above, a connection structure of an electric wire and a terminal according to the fifth aspect of the invention is characterized in that in the terminal and the insulating coated part of a side extending from the first crimp part toward a direction opposite to an end of the electric wire, a substrate with improved adhesion is formed on a surface by applying a primer agent.

[0018] Also, in the invention described above, a connection structure of an electric wire and a terminal according to the sixth aspect of the invention is characterized in that the first crimp part is formed so as to increase a cross-sectional area orthogonal to an extension direction of the electric wire surrounded by the first crimp part.

[0019] Also, in the invention described above, a connection structure of an electric wire and a terminal according to the seventh aspect of the invention is characterized in that an external shape of a cross section orthogonal to an extension direction of the electric wire is a rectangular shape in the first crimp part.

[0020] Also, in the invention described above, a connection structure of an electric wire and a terminal according to the eighth aspect of the invention is characterized in that the conductor part is made of aluminum, and the terminal is made of metal different from that of the conductor part.

[0021] In order to solve the problems described above and achieve the object, a manufacturing method of a connection structure of an electric wire and a terminal according to the ninth aspect of the invention is the manufacturing method of the connection structure of the electric wire and the terminal, the structure having the electric wire having an insulating coated part in which a conductor part is covered with an insulating material, and a conductor exposed part in which the insulating material of an end of the electric wire is removed, and the terminal including a first crimp part crimped to the insulating coated part, and a second crimp part crimped to the conductor exposed part, and is characterized by including a seal part formation step of forming a seal part which is made of thermoplastic elastomer and covers a surface including the first crimp part and the insulating coated part of a side extending from the first crimp part toward a direction opposite to the end of the electric wire and a surface of the second crimp part in an extension direction of the electric wire so as to seamlessly cover an outer periphery of the electric wire when viewed in a cross section orthogonal to the extension direction thereof by a metallic mold, the seal part formation step in which a gate of the metallic mold is arranged separately from a formation position of an end of the seal part toward the extension direction of the electric wire and the inside of the metallic mold is filled with the seal part.

[0022] Also, in the invention described above, a manufacturing method of a connection structure of an electric wire and a terminal according to the tenth aspect of the invention is characterized in that in the seal part formation step, the gate is arranged in a surface extending to an end of the electric wire.

[0023] In order to solve the problems described above and achieve the object, a manufacturing method of a connection structure of an electric wire and a terminal according to the eleventh aspect of the invention is the manufacturing method of the connection structure of the electric wire and the terminal, the structure having the electric wire having an insulating coated part in which a conductor part is covered with an insulating material, and a conductor exposed part in which the insulating material of an end of the electric wire is removed, and the box-shaped terminal having a first crimp part crimped to the insulating coated part, a second crimp part crimped to the conductor exposed part, and a notched part in which a notch is formed in an upper part between the first crimp part and the second crimp part, and is characterized by including a crimping step of crimping the first crimp part or the second crimp part while covering the notched part together with the first crimp part or the second crimp part with a crimp surface of crimp means in the case of crimping the first crimp part or the second crimp part by pressing the crimp surface of the crimp means, and a seal part formation step of forming a seal part which is made of thermoplastic elastomer and covers a surface including the first crimp part and the insulating coated part of a side extending from the first crimp part toward a direction opposite to the end of the electric wire, a surface of the second crimp part and a surface of the notched part in an extension direction of the electric wire so as to seamlessly cover an outer periphery of the electric wire when viewed in a cross section orthogonal to the extension direction thereof by a metallic mold.

[0024] The connection structure of the electric wire and the terminal according to the first aspect of the invention has the seal part which is made of thermoplastic elastomer and covers the surface including the first crimp part and the insulating coated part of the side extending from the first crimp part toward the direction opposite to the end of the electric wire and the surface of the second crimp part in the extension direction of the electric wire, and the outer periphery of the electric wire is seamlessly covered with the seal part when viewed in a cross section orthogonal to the extension direction of the electric wire, so that peeling of the seal part by an external force can be prevented to increase waterproof properties, with the result that corrosion-proof properties can be improved.

[0025] The connection structure of the electric wire and the terminal according to the second aspect of the invention has the seal part which is made of thermoplastic elastomer and covers the surface including the first crimp part and the insulating coated part of the side extending from the second crimp part toward the direction opposite to the end of the electric wire, the surface of the second crimp part and the notched part in the extension direction of the electric wire, and the outer periphery of the electric wire is seamlessly covered with the seal part when viewed in a cross section orthogonal to the extension direction, so that peeling of the seal part by an external force can be prevented to increase waterproof properties, with the result that corrosion-proof properties can be improved.

[0026] In the connection structure of the electric wire and the terminal according to the third aspect of the invention, while having an effect similar to the first aspect of the invention described above, the seal part of the inside and the outside of the side wall of the terminal is joined through the seal part with which the opening part is filled, so that the seal part functions as a holding part of the seal part with respect to an external force, and peeling of the seal part can be prevented.

[0027] In the connection structure of the electric wire and the terminal according to the fourth aspect of the invention, while having an effect similar to the first aspect of the invention described above, the surface of the insulating part covered with the seal part has the uneven shape, so that a surface area of a surface of adhesion between the insulating part and the seal part increases and also the strength of adhesion between the insulating part and the seal part improves by an anchor effect caused by entrance of the seal part into recesses of the surface of the insulating part.

[0028] In the connection structure of the electric wire and the terminal according to the fifth aspect of the invention, while having an effect similar to the first aspect of the invention described above, the strength of adhesion between the insulating coated part and the seal part and also between the terminal and the seal part is improved by forming the substrate on the surface of the insulating coated part covered with the seal part. As a result, peeling of the seal part can be prevented to increase waterproof properties, with the result that corrosion-proof properties can be improved.

[0029] In the connection structure of the electric wire and the terminal according to the sixth aspect of the invention, while having an effect similar to the first aspect of the invention described above, the first crimp part is formed so as to increase the cross-sectional area orthogonal to the extension direction of the electric wire surrounded by the first crimp part, so that the insulating part is prevented from swelling in the vicinity of the portion of crimping the first crimp part and

a thickness of the seal part is prevented from becoming thin in this swelling portion, so that waterproof properties can be increased, with the result that corrosion-proof properties can be improved.

[0030] In the connection structure of the electric wire and the terminal according to the seventh aspect of the invention, while having an effect similar to the first aspect of the invention described above, the structure is constructed so as to increase the cross-sectional area orthogonal to the extension direction of the electric wire surrounded by the first crimp part, so that the insulating part is prevented from swelling in the vicinity of the portion of crimping the first crimp part and a thickness of the seal part is prevented from becoming thin in this swelling portion, so that waterproof properties can be increased, with the result that corrosion-proof properties can be improved.

[0031] In the connection structure of the electric wire and the terminal according to the eighth aspect of the invention, while having an effect similar to the first aspect of the invention described above, also in the case of using aluminum in the conductor part, peeling of the seal part can be prevented to increase waterproof properties, with the result that corrosion-proof properties can be improved.

[0032] Since the manufacturing method of the connection structure of the electric wire and the terminal according to the ninth aspect of the invention forms the seal part which is made of thermoplastic elastomer and covers the surface including the first crimp part and the insulating coated part of the side extending from the first crimp part toward the direction opposite to the end of the electric wire and the surface of the second crimp part in the extension direction of the electric wire so as to seamlessly cover the outer periphery of the electric wire when viewed in a cross section orthogonal to the extension direction thereof by the metallic mold, while having an effect similar to the first aspect of the invention described above, occurrence of peeling of the seal part in the vicinity of the gate of the metallic mold can be prevented to increase waterproof properties, with the result that corrosion-proof properties can be improved.

[0033] In the manufacturing method of the connection structure of the electric wire and the terminal according to the tenth aspect of the invention, while having an effect similar to the ninth aspect of the invention described above, thermoplastic elastomer becomes easy to flow by an effect of a step by the end of the electric wire, so that filling properties are not reduced.

[0034] Since the manufacturing method of the connection structure of the electric wire and the terminal according to the eleventh aspect of the invention forms the seal part which is made of thermoplastic elastomer and covers the surface including the first crimp part and the insulating coated part of the side extending from the first crimp part toward the direction opposite to the end of the electric wire, the surface of the second crimp part and the surface of the notched part in the extension direction of the electric wire so as to seamlessly cover the outer periphery of the electric wire when viewed in a cross section orthogonal to the extension direction thereof by the metallic mold, while having an effect similar to the second aspect of the invention described above, the first crimp part is crimped while covering the notched part with the crimp surface of the first crimp part by increasing the width of the first crimp part, so that the notched part can be prevented from swelling. As a result, a thickness of the seal part is prevented

from becoming thin, so that waterproof properties can be increased, with the result that corrosion-proof properties can be improved.

BRIEF DESCRIPTION OF THE DRAWINGS

[0035] FIG. 1 is a plan view showing a connection structure of an electric wire and a terminal according to a first embodiment of the invention.

[0036] FIG. 2 is a side view showing the connection structure of the electric wire and the terminal according to the first embodiment of the invention.

[0037] FIGS. 3A and 3B are diagrams describing a relation between a molecular size and an intermolecular force.

[0038] FIG. 4 is a main sectional view showing a metallic mold and the connection structure of the electric wire and the terminal.

[0039] FIG. 5 is a sectional view taken on line A-A of the main sectional view shown in FIG. 4.

[0040] FIGS. 6A and 6B are diagrams describing a state of a seal part by separation of a gate in the case of arranging a position of the gate of a metallic mold in the vicinity of the end of the seal part.

[0041] FIG. 7 is a diagram showing a metallic mold in which a position of a gate used in a manufacturing method of a connection structure of an electric wire and a terminal of a second embodiment of the invention is displaced, and the connection structure of the electric wire and the terminal.

[0042] FIG. 8 is a diagram showing one example of the displaced position of the gate.

[0043] FIG. 9 is a diagram showing a connection structure of an electric wire and a terminal of a third embodiment of the invention.

[0044] FIG. 10 is a sectional view taken on line B-B of the connection structure of the electric wire and the terminal shown in FIG. 9.

[0045] FIG. 11 is a diagram showing a connection structure of an electric wire and a terminal of a fourth embodiment of the invention.

[0046] FIG. 12 is an enlarged sectional view of a part of adhesion between an insulating coated part and a seal part.

[0047] FIG. 13 is a diagram showing a connection structure of an electric wire and a terminal of a fifth embodiment of the invention.

[0048] FIG. 14 is a diagram showing a modified example of the connection structure of the electric wire and the terminal of the fifth embodiment of the invention.

[0049] FIG. 15 is a diagram showing a connection structure of an electric wire and a terminal of a sixth embodiment of the invention.

[0050] FIG. 16 is a sectional view taken on line C-C of the connection structure of the electric wire and the terminal shown in FIG. 15.

[0051] FIG. 17 is a diagram describing the fact that an insulating coated part swells in the vicinity of an insulation barrel.

[0052] FIG. 18 is a sectional view taken on line D-D of the connection structure of the electric wire and the terminal shown in FIG. 17.

[0053] FIG. 19 is a diagram describing an anvil and a crimper used in crimping of the insulation barrel.

[0054] FIG. 20 is a diagram showing a modified example of the connection structure of the electric wire and the terminal of the sixth embodiment of the invention.

[0055] FIG. 21 is a main side view of a terminal before the terminal is crimped, an insulation crimper and a wire crimper of a seventh embodiment of the invention.

[0056] FIG. 22 is a main side view of the terminal before the terminal is crimped, an insulation crimper and a wire crimper of the seventh embodiment of the invention.

[0057] FIG. 23 is a main side view of the terminal before the terminal is crimped, an insulation crimper and a wire crimper.

[0058] FIG. 24 is a diagram describing the fact that a notched part swells.

[0059] FIG. 25 is a diagram showing a normal crimp state of the terminal.

DETAILED DESCRIPTION OF THE EXEMPLARY EMBODIMENTS

[0060] Preferred embodiments of a connection structure of an electric wire and a terminal according to the invention and a manufacturing method of the structure of connection will hereinafter be described in detail with reference to the drawings.

First Embodiment

[0061] FIG. 1 is a plan view showing a connection structure 1 of an electric wire and a terminal according to a first embodiment of the invention. FIG. 2 is a side view showing the connection structure 1 of the electric wire and the terminal according to the embodiment of the invention. The connection structure 1 of the electric wire and the terminal has an electric wire 10, a terminal 20 and a seal part 60.

[0062] The electric wire 10 has an insulating coated part 11 and a conductor exposed part 12.

[0063] The insulating coated part 11 is the portion in which a conductor part 12b obtained by bundling plural core wires 12a made of an aluminum material is coated with an insulating part 11a made of an insulating material such as polypropylene (PP). In addition, the insulating part 11a is not limited to polypropylene and other insulating materials may be used.

[0064] The conductor exposed part 12 is the portion in which the insulating part 11a of the end of the electric wire 10 is removed and the conductor part 12b is exposed.

[0065] The terminal 20 has a box shape made of copper. This terminal 20 is formed by, for example, pressing a copper plate. The terminal 20 has an electric wire connection part 30, another terminal connection part 40 and a notched part 50.

[0066] The electric wire connection part 30 has an insulation barrel 31 as a first crimp part, and a wire barrel 32 as a second crimp part.

[0067] The insulation barrel 31 is the portion crimped to the insulating coated part 12 of the electric wire 10 by, for example, a crimper and an anvil.

[0068] The wire barrel 32 is the portion crimped by, for example, a crimper and an anvil to the conductive wire part 11 exposed by removing the insulating coated part 12 of the electric wire 10.

[0069] The other terminal connection part 40 has a box shape, and is the portion electrically connected to a male terminal used as the connection other side.

[0070] The notched part 50 has a box shape in which a notch is formed in the upper part. This notched part 50 has a first notched part 51 and a second notched part 52. The first notched part 51 is a notched part formed between the insulation barrel 31 and the wire barrel 32. The second notched part

52 is a notched part formed between the wire barrel 32 and the other terminal connection part 40.

[0071] The seal part 60 is made of thermoplastic elastomer and is formed using a metallic mold. This seal part 60 is formed so as to cover a surface including the insulation barrel 31 and the insulating coated part 11 of the side extending from the insulation barrel 31 toward a direction opposite to the end of the electric wire 10, a surface of the wire barrel 32, a surface of the first notched part 51 and the second notched part 52 in an extension direction of the electric wire 10. Also, the outer periphery of the electric wire 10 is integrally covered with the seal part 60 when viewed in a cross section orthogonal to the extension direction. That is, the outer periphery of the electric wire 10 is seamlessly covered with the seal part 60 when viewed in a cross section orthogonal to the extension direction.

[0072] Also, the seal part 60 is formed so as not to have seams of the surface including the insulation barrel 31 and the insulating coated part 11 of the side extending from the insulation barrel 31 toward the direction opposite to the end of the electric wire 10, the surface of the wire barrel 32, the surface of the first notched part 51 and the second notched part 52 in the extension direction of the electric wire 10.

[0073] In this embodiment, thermoplastic elastomer with a high intermolecular force to a material used in the insulating coated part 11 is used as the seal part 60.

[0074] Here, the intermolecular force between molecules of the insulating material for forming the insulating part 11a of the insulating coated part 11 and elastomer molecules of the thermoplastic elastomer will be described. FIG. 3 is a diagram describing a relation between a molecular size and the intermolecular force.

[0075] In the connection structure 1 of the electric wire and the terminal, it is necessary to improve adhesion between the insulating part 11a and the seal part 60 in order to withstand repeated bends of the electric wire 10.

[0076] Because of this, a kind of thermoplastic elastomer is selected according to the required quality of bend durability etc. of the electric wire 10 and the terminal 20. That is, the strength of adhesion between the seal part 60 and the terminal 20 or the strength of adhesion between the seal part 60 and the insulating part 11a is set by selecting the kind of thermoplastic elastomer. For example, when the required quality of bend is high, it is necessary to increase the strength of adhesion between the seal part 60 and the insulating part 11a, so that the thermoplastic elastomer in which a strong intermolecular force acts on the insulating part 11a is selected.

[0077] In addition, in the intermolecular force between molecules M1 of the material for forming the insulating part 11a and elastomer molecules M2 of the thermoplastic elastomer, a stronger intermolecular force can be obtained since a gap in the case where sizes of both the molecules are equal (FIG. 3B) becomes smaller than a gap in the case where the sizes of both the molecules differ (FIG. 3A) as shown in FIG. 3.

[0078] Here, the seal part 60 formed using a metallic mold 70 will concretely be described using FIGS. 4 and 5.

[0079] FIG. 4 is a main sectional view showing the metallic mold 70 and the connection structure 1 of the electric wire and the terminal. FIG. 5 is a sectional view taken on line A-A of the main sectional view shown in FIG. 4.

[0080] The metallic mold 70 is a metallic mold used generally, and has an upper metallic mold 71 and a lower metallic mold 72 as shown in FIG. 4. The upper metallic mold 71 has

a gate **71a** and flash cut parts **71b**. The lower metallic mold **72** has pushpins **72a** and flash cut parts **72b**.

[0081] A position of the gate **71a** is disposed in the vicinity of the end of the seal part **60** in order to enhance filling properties of thermoplastic elastomer in the end of the seal part **60**.

[0082] As shown in FIG. 5, the thermoplastic elastomer which is the seal part **60** is formed so as to seamlessly cover the outer periphery the portion of connection between the electric wire and the terminal when viewed in a cross section orthogonal to the extension direction.

[0083] The connection structure **1** of the electric wire and the terminal of the first embodiment of the invention has the seal part **60** which is made of the thermoplastic elastomer and covers a surface including the insulation barrel **31** and the insulating coated part **11** of the side extending from the insulation barrel **31** toward a direction opposite to the end of the electric wire **10** and a surface of the wire barrel **32** in the extension direction of the electric wire **10**, and the outer periphery of the electric wire **10** is seamlessly covered with the seal part **60** when viewed in a cross section orthogonal to the extension direction, so that peeling of the seal part **60** by an external force can be prevented to increase waterproof properties, with the result that corrosion-proof properties can be improved.

[0084] Also, in the connection structure **1** of the electric wire and the terminal of the first embodiment of the invention, the surface of the insulating coated part **11** of the side extending from the insulation barrel **31** toward the direction opposite to the end of the electric wire **10** is covered with the seal part **60**, so that waterproof properties of the portion which tends to be bent can be improved. Further, since the thermoplastic elastomer having elasticity is used as the seal part **60**, the thermoplastic elastomer becomes easy to follow the bending and thereby, peeling of the seal part **60** can be prevented to increase waterproof properties, with the result that corrosion-proof properties can be improved.

Second Embodiment

[0085] Next, a manufacturing method of a connection structure **1** of an electric wire and a terminal of a second embodiment of the invention will be described using FIGS. 6A to 8. FIGS. 6A and 6B are diagrams describing a state of a seal part **60** by separation of a gate **71a** in the case of arranging a position of the gate **71a** of a metallic mold **70** in the vicinity of the end of the seal part **60**. FIG. 7 is a diagram showing the metallic mold **70** in which the position of the gate **71a** used in the manufacturing method of the connection structure **1** of the electric wire and the terminal of the second embodiment of the invention is displaced, and the connection structure **1** of the electric wire and the terminal. FIG. 8 is a diagram showing one example of the displaced position of the gate **71a**. In addition, in FIGS. 6A and 6B, a diagram arranged in the right side is a main sectional view of the diagram arranged in the left side.

[0086] Also, the same numerals are assigned to the same components as those of the first embodiment described above.

[0087] The first embodiment of the invention illustrates the case of arranging the gate **71a** of the metallic mold **70** in the vicinity of the end of the seal part **60** when the seal part **60** using the metallic mold **70** is formed, but in this case, the end **60a** of the seal part **60** tends to be pulled by separation of the gate **71a** as shown in FIGS. 6A and 6B. As a result, while a

terminal **20** is seamlessly covered with the seal part **60**, peeling **60b** of the seal part **60** may occur in the vicinity of this gate **71a** as shown in the right diagram of FIG. 6B.

[0088] Hence, the manufacturing method of the connection structure **1** of the electric wire and the terminal of this second embodiment is constructed so that the gate **71a** of the metallic mold **70** is arranged separately from a formation position of the end of the seal part **60** toward an extension direction of an electric wire **10** and the inside of the metallic mold **70** is filled with the seal part **60**.

[0089] In a metallic mold **80** used in the manufacturing method of the connection structure **1** of the electric wire and the terminal of this second embodiment, the gate **71a** is disposed in a position separate from a formation position of the end **60a** of the seal part **60** toward the extension direction of the electric wire **10** as shown in FIG. 7. As a result, a surface of an upper metallic mold **81** abutting on the seal part **60** in the vicinity of the end **60a** of the seal part **60** functions as a press part **81a** used as a press, and the end **60a** of the seal part **60** is prevented from being pulled by separation of the gate **71a**.

[0090] In addition, it is more preferable to arrange the gate **71a** in the surface extending to an end **10a** of the electric wire as shown in FIG. 8. When the gate **71a** is arranged thus, thermoplastic elastomer becomes easy to flow to a position of a flash cut part **71b** by an effect of a step by the end **10a**, so that filling properties are not reduced.

[0091] In the connection structure **1** of the electric wire and the terminal manufactured using the metallic mold **80** shown in this second embodiment, while having an effect similar to the connection structure **1** of the electric wire and the terminal of the first embodiment, occurrence of peeling of the seal part **60** in the vicinity of the gate **71a** of the metallic mold **80** can be prevented to increase waterproof properties, with the result that corrosion-proof properties can be improved.

Third Embodiment

[0092] Next, a third embodiment of the invention will be described using FIGS. 9 and 10. FIG. 9 is a diagram showing a structure **2** of connection between an electric wire and a terminal of the third embodiment of the invention. FIG. 10 is a sectional view taken on line B-B of the structure **2** of connection between the electric wire and the terminal shown in FIG. 9.

[0093] Also, the same numerals are assigned to the same components as those of the first and second embodiments described above.

[0094] The structure **2** of connection between an electric wire **10** and a terminal **21** of this third embodiment has a configuration of preventing occurrence of peeling in the vicinity of the gate **71a** described in the second embodiment. In the structure **2** of connection between the electric wire **10** and the terminal **21**, a rectangular opening part **21a** is formed in the terminal **21** as shown in FIG. 9.

[0095] The opening parts **21a** are formed in side walls **21b**, **21b** covered with a seal part **60**. More concretely, the opening parts **21a** are formed in both the side walls **21b**, **21b** of the terminal **21** positioned in the lower vicinity of an upper metallic mold **71** in a state of being set in a metallic mold **70**. Since the opening parts **21a** are filled with thermoplastic elastomer of the seal part **60**, the opening parts **21a** prevent the seal part **60** from being pulled by separation of the gate **71a**.

[0096] According to the structure **2** of connection between the electric wire **10** and the terminal **21** of this third embodiment, occurrence of peeling of the seal part **60** in the vicinity

of the gate **71a** of the metallic mold **70** can be prevented while having an effect similar to the connection structure **1** of the electric wire and the terminal of the first embodiment.

[0097] In addition, in the structure **2** of connection between the electric wire and the terminal of this third embodiment, the example of forming the opening parts **21a** in the vicinity of the gate **71a** is illustrated, but the example is not limited to this example. That is, the opening parts **21a** could be formed in the side walls of the terminal **21** in which the seal part **60** is formed, that is, the side walls covered with the seal part **60**. In this case, the seal part **60** of the inside and the outside of the side walls of the terminal **21** is joined through the seal part **60** with which the opening parts **21a** are filled. The seal part **60** with which the opening parts **21a** are filled functions as a holding part of the seal part **60** with respect to an external force. As a result, the structure **2** of connection between the electric wire and the terminal of this third embodiment can prevent peeling of the seal part **60** to increase waterproof properties, with the result that corrosion-proof properties can be improved.

[0098] Also, in this third embodiment, the example in which the opening part **21a** has the rectangular shape is illustrated, but the example is not limited to this example. For example, the opening part **21a** may have a circular shape.

Fourth Embodiment

[0099] Next, a fourth embodiment of the invention will be described using FIGS. **11** and **12**. FIG. **11** is a diagram showing a structure **3** of connection between an electric wire and a terminal of the fourth embodiment of the invention. FIG. **12** is an enlarged sectional view of a part E of adhesion between an insulating coated part **11** and a seal part **60**.

[0100] Also, the same numerals are assigned to the same components as those of the first to third embodiments described above.

[0101] In the structure **3** of connection between the electric wire and the terminal of this fourth embodiment, a surface of the insulating coated part **11** of the side extending from an insulation barrel **31** toward a direction opposite to the end of an electric wire **13** has an uneven shape by roughening treatment as shown in FIG. **11**. More concretely, a roughened surface **11b** is formed by performing surface roughening treatment on the surface of an insulating part **11a** covered with the seal part **60**. This surface roughening treatment includes blast treatment, plasma treatment, etc.

[0102] The surface roughening treatment is performed after crimping or at the time of crimping or peeling the insulating part **11a**. When the surface roughening treatment is performed at the time of peeling the insulating part **11a**, for example, a surface of a clamp part of a crimper for clamping the electric wire **13** is formed in an uneven shape and a surface of contact with the electric wire **13** of the insulating part **11a** is clamped and thereby, the surface roughening treatment can be performed without adding a process.

[0103] In the structure **3** of connection between the electric wire **13** and the terminal **20** of this fourth embodiment, the surface of the insulating part **11a** covered with the seal part **60** has the uneven shape as shown in FIG. **12**, so that a surface area of a surface of adhesion between the insulating part **11a** and the seal part **60** increases and also the strength of adhesion between the insulating part **11a** and the seal part **60** improves by an anchor effect caused by entrance of the seal part **60** into recesses of the surface of the insulating part **11a**. That is, the structure **3** of connection between the electric wire and the

terminal of this fourth embodiment can prevent peeling of the seal part **60** to increase waterproof properties, with the result that corrosion-proof properties can be improved.

Fifth Embodiment

[0104] Next, a fifth embodiment of the invention will be described using FIG. **13**.

[0105] FIG. **13** is a diagram showing a structure **4** of connection between an electric wire and a terminal of the fifth embodiment of the invention.

[0106] In addition, the same numerals are assigned to the same components as those of the embodiments described above.

[0107] In the structure **4** of connection between the electric wire and the terminal of this fifth embodiment, a substrate **11c** is formed on a surface of an insulating coated part **11** of the side extending from an insulation barrel **31** toward a direction opposite to the end of an electric wire **14** as shown in FIG. **13**. More concretely, on the surface of the insulating coated part **11** covered with a seal part **60**, the substrate **11c** is formed by applying an adhesive such as a primer.

[0108] In the structure **4** of connection between the electric wire and the terminal of this fifth embodiment, the strength of adhesion between the insulating coated part **11** and the seal part **60** is improved by forming the substrate **11c** on the surface of the insulating coated part **11** covered with the seal part **60**. As a result, peeling of the seal part **60** can be prevented to increase waterproof properties, with the result that corrosion-proof properties can be improved.

[0109] In addition, when ITRO (registered trademark) treatment is performed on the surface of the insulating coated part **11** as pretreatment in the case of forming this substrate **11c**, wettability of the surface improves and the strength of adhesion between the insulating coated part **11** and the seal part **60** can be improved more.

[0110] Also, the strength of adhesion between a terminal **20** and the seal part **60** can be improved by further performing pretreatment on a surface of the terminal **20** like the insulating coated part **11** as shown in FIG. **14**.

Sixth Embodiment

[0111] Next, a sixth embodiment of the invention will be described using FIGS. **15** to **20**. FIG. **15** is a diagram showing a structure **5** of connection between an electric wire and a terminal of the sixth embodiment of the invention. FIG. **16** is a sectional view taken on line C-C of the structure **5** of connection between the electric wire and the terminal shown in FIG. **15**. FIG. **17** is a diagram describing the fact that an insulating coated part **11** swells in the vicinity of an insulation barrel **31**. FIG. **18** is a sectional view taken on line D-D of the connection structure **1** of the electric wire and the terminal shown in FIG. **17**. FIG. **19** is a diagram describing an anvil **91** and a crimper **92** used in crimping of the insulation barrel **31**. FIG. **20** is a diagram showing a modified example of the structure **5** of connection between the electric wire and the terminal of the sixth embodiment of the invention.

[0112] Also, the same numerals are assigned to the same components as those of the first to fifth embodiments described above.

[0113] In the connection structure **1** of the electric wire **10** and the terminal **20** of the first embodiment of the invention, an insulating part **11a** swells in the vicinity of the portion of crimping the insulation barrel **31** as shown in FIGS. **17** and

18. As a result, a swelling portion P of the insulating part **11a** inhibits formation of the seal part **60** and a thickness of the seal part in the swelling portion P becomes thin, with the result that waterproof properties decrease.

[0114] Hence, in the structure **5** of connection between the electric wire and the terminal of this sixth embodiment, an external shape of a cross section orthogonal to an extension direction of the electric wire **10** is formed in a rectangular shape as shown in FIG. **16**. That is, in an insulation barrel **33**, the external shape of the cross section orthogonal to the extension direction of the electric wire **10** is formed in the rectangular shape and a cross-sectional area orthogonal to the extension direction of the electric wire **10** surrounded by the insulation barrel **33** is increased. When the insulation barrel **33** is formed thus, for example, the insulation barrel is crimped using the anvil **91** and the crimper **92** shown in FIG. **19**.

[0115] Since the structure **5** of connection between the electric wire and the terminal of this sixth embodiment is constructed so as to increase the cross-sectional area orthogonal to the extension direction of the electric wire **10** surrounded by the insulation barrel **33**, the insulating part **11a** is prevented from swelling in the vicinity of the portion of crimping the insulation barrel **33** and a thickness of the seal part **60** is prevented from becoming thin, so that waterproof properties can be increased, with the result that corrosion-proof properties can be improved.

[0116] In addition, in the structure **5** of connection between the electric wire and the terminal of the sixth embodiment of the invention, the example in which the external shape of the cross section orthogonal to the extension direction of the electric wire **10** is formed in the rectangular shape is illustrated, but the example is not limited to this example. That is, the insulation barrel **31** could be formed so as to increase the cross-sectional area orthogonal to the extension direction of the electric wire **10** surrounded by the insulation barrel **31**. For example, the insulation barrel **33** may be formed so that the external shape of the cross section orthogonal to the extension direction of the electric wire **10** is formed in a circular shape as shown in FIG. **20**.

Seventh Embodiment

[0117] Next, a seventh embodiment of the invention will be described using FIGS. **21** to **25**. FIG. **21** is a main side view showing a terminal **20** before the terminal is crimped, an insulation crimper **94** and a wire crimper **95** of the seventh embodiment of the invention. FIG. **22** is a main side view showing the terminal **20** before the terminal is crimped, an insulation crimper **98** and a wire crimper **97** of the seventh embodiment of the invention. FIG. **23** is a main side view showing the terminal **20** before the terminal is crimped, an insulation crimper **96** and the wire crimper **95**. FIG. **24** is a diagram describing the fact that a notched part **51** swells. FIG. **25** is a diagram showing a normal crimp state of the terminal **20**.

[0118] Also, the same numerals are assigned to the same components as those of the first to sixth embodiments described above.

[0119] Conventionally, a width (C/W) after crimping an insulation barrel **31** is set more widely than a wire barrel **32** as shown in FIG. **25**. This is because the insulation barrel **31** is crimped to an insulating coated part **11** coated with an insulating part **11a** and the wire barrel **32** is crimped to a conductor exposed part **12** in which the insulating part **11a** is

removed. Also, each of the crimpers **95**, **96** is constructed so as to press inside the surfaces of the insulation barrel **31** and the wire barrel **32** as shown in FIG. **23**.

[0120] As a result, when the wire barrel **32** and the insulation barrel **31** are respectively crimped by the wire crimper **95** and the insulation crimper **96** and become the same width (C/W), or when the insulation barrel **31** becomes the width (C/W) narrower than the wire barrel **32**, the insulation barrel **31** tends to escape to the notched part **51** without the press as shown in FIG. **24**, so that side walls **51a**, **51a** of the notched part **51** swell.

[0121] When the side walls **51a**, **51a** of the notched part **51** swell thus, a film thickness of a seal part **60** of the swelling portion is formed thinly, with the result that waterproof properties decrease.

[0122] Hence, in a manufacturing method of the connection structure **1** of the electric wire and the terminal of this seventh embodiment, as shown in FIG. **21**, a width of the insulation crimper **94** as crimp means is increased and the notched part **51** is covered in the case of crimping.

[0123] Consequently, in the case of crimping by pressing a crimp surface of the insulation crimper **94** to the insulation barrel **31**, the insulation barrel **31** is crimped while covering the notched part **51** with the crimp surface of the insulation crimper **94**.

[0124] In the manufacturing method of the connection structure **1** of the electric wire and the terminal of this seventh embodiment, the insulation barrel **31** is crimped while covering the notched part **51** with the crimp surface of the insulation crimper **94** by increasing the width of the insulation crimper **94**, so that the notched part **51** is prevented from swelling, with the result that a thickness of the seal part **60** is prevented from becoming thin. As a result, the connection structure **1** of the electric wire and the terminal of this seventh embodiment can increase waterproof properties, with the result that corrosion-proof properties can be improved.

[0125] In addition, in the manufacturing method of the connection structure **1** of the electric wire and the terminal of this seventh embodiment, the example of covering the notched part **51** by increasing the width of the insulation crimper **94** is illustrated, but the example is not limited to this example. That is, the wire barrel **32** may be crimped while covering the notched part **51** with a crimp surface of the wire crimper **97** by increasing a width of the wire crimper **97** and covering the notched part **51** as shown in FIG. **22**.

[0126] In addition, in the first to seventh embodiments of the invention, the example in which the terminals **20**, **21**, **22** are copper is illustrated, but the example is not limited to this example. For example, the terminal made of an alloy of copper and nickel may be used.

[0127] Also, in the first to seventh embodiments of the invention, the example in which the structures **1**, **2**, **3**, **4**, **5** of connection between the electric wire and the terminal have the first notched part **51** and the second notched part **52** is illustrated, but the example is not limited to this example. That is, a terminal structure in which the notched part **50** is not provided may be used.

[0128] Also, in the first to seventh embodiments of the invention, the example in which the seal part **60** is formed so as not to have seams of the surface including the insulation barrel **31** and the insulating coated part **11** of the side extending from the insulation barrel **31** toward the direction opposite to the end of the electric wire **10**, the surface of the wire barrel **32**, the surface of the first notched part **51** and the second

notched part **52** in the extension direction of the electric wire **10** is illustrated, but the example is not limited to this example. That is, the seal part **60** may be separated in the extension direction of the electric wire **10**.

[0129] In addition, this invention is not limited by the embodiments.

[0130] The invention is applicable to provide a connection structure of an electric wire and a terminal capable of improving corrosion-proof properties.

REFERENCE SIGNS LIST

- [0131] **1,2,3,4,5** CONNECTION STRUCTURE OF ELECTRIC WIRE AND TERMINAL
- [0132] **10,13,14** ELECTRIC WIRE
- [0133] **10a** END
- [0134] **11** INSULATING COATED PART
- [0135] **11a** INSULATING PART
- [0136] **11b** ROUGHENED SURFACE
- [0137] **11c** SUBSTRATE WITH IMPROVED ADHESION
- [0138] **12** CONDUCTOR EXPOSED PART
- [0139] **12a** CORE WIRE
- [0140] **12b** CONDUCTOR PART
- [0141] **20,21,22** TERMINAL
- [0142] **21a** OPENING PART
- [0143] **30** ELECTRIC WIRE CONNECTION PART
- [0144] **31,33** INSULATION BARREL
- [0145] **32** WIRE BARREL
- [0146] **40** OTHER TERMINAL CONNECTION PART
- [0147] **50,51,52** NOTCHED PART
- [0148] **60** SEAL PART
- [0149] **60a** END
- [0150] **70,80** METALLIC MOLD
- [0151] **71,81** UPPER METALLIC MOLD

- [0152] **71a** GATE
- [0153] **71b,72b** FLASH CUT PART
- [0154] **72,82** LOWER METALLIC MOLD
- [0155] **72a** PUSHPIN
- [0156] **81a** PRESS PART
- [0157] **91** ANVIL
- [0158] **92** CRIMPER
- [0159] **94,96,98** INSULATION CRIMPER
- [0160] **95,97** WIRE CRIMPER

What is claimed is:

1. A manufacturing method of a connection structure of an electric wire and a terminal, the electric wire having an insulating coated part in which a conductor part is covered with an insulating material, and a conductor exposed part in which the insulating material of an end of the electric wire is removed, and the terminal is a box-shaped terminal having a first crimp part crimped to the insulating coated part, a second crimp part crimped to the conductor exposed part, and a notched part in which a notch is formed in an upper part between the first crimp part and the second crimp part, the method comprising:
 crimping the first crimp part while covering the notched part together with the first crimp part with a crimp surface of a crimp device in the case of crimping the first crimp part by pressing the crimp surface of the crimp device, and
 forming a seal part which is made of thermoplastic elastomer and covers a surface including the first crimp part and the insulating coated part of a side extending from said first crimp part toward a direction opposite to the end of the electric wire, a surface of the second crimp part and a surface of the notched part in an extension direction of the electric wire so as to seamlessly cover an outer periphery of the electric wire when viewed in a cross section thereof by a metallic mold.

* * * * *