



US 20180152133A1

(19) **United States**

(12) **Patent Application Publication**
Schaefer et al.

(10) **Pub. No.: US 2018/0152133 A1**

(43) **Pub. Date: May 31, 2018**

(54) **ADJUSTABLE COMBINED FLASHING AND MOUNTING APPARATUS AND METHOD OF MOUNTING TO BE USED THEREWITH**

Publication Classification

(51) **Int. Cl.**
H02S 20/23 (2006.01)
(52) **U.S. Cl.**
CPC **H02S 20/23** (2014.12); **Y02B 10/12** (2013.01); **Y02E 10/47** (2013.01); **F24J 2/5245** (2013.01); **Y02B 10/20** (2013.01)

(71) Applicant: **D Three Enterprises LLC**, Lafayette, CO (US)

(72) Inventors: **Richard F. Schaefer**, Fort Lupton, CO (US); **David Kreutzman**, Louisville, CO (US)

(73) Assignee: **D Three Enterprises LLC**, Lafayette, CO (US)

(57) **ABSTRACT**

The present disclosure is directed to a roof mounting system that utilizes a base plate that is affixed to a roof surface by multiple fasteners (e.g., lag bolts, screws etc.) and a cap (e.g., top cap) that attaches to the base plate covering the fasteners affixing the base plate to the roof surface. Once attached, the top cap covers the fasteners preventing water infiltration. To further waterproof the fasteners affixing the base plate to the roof surface, the base plate includes a raised or elevated section on its top surface with a planar flange extending around the elevated section. A portion of the flange may be disposed beneath a single or shingles on a roof surface. The fasteners extend through the elevated section. Accordingly, water drains around the elevated section when the base plate is attached to a roof surface further isolating the fasteners.

(21) Appl. No.: **15/616,743**

(22) Filed: **Jun. 7, 2017**

Related U.S. Application Data

(63) Continuation of application No. 14/608,569, filed on Jan. 29, 2015, now Pat. No. 9,680,409.

(60) Provisional application No. 61/933,004, filed on Jan. 29, 2014.

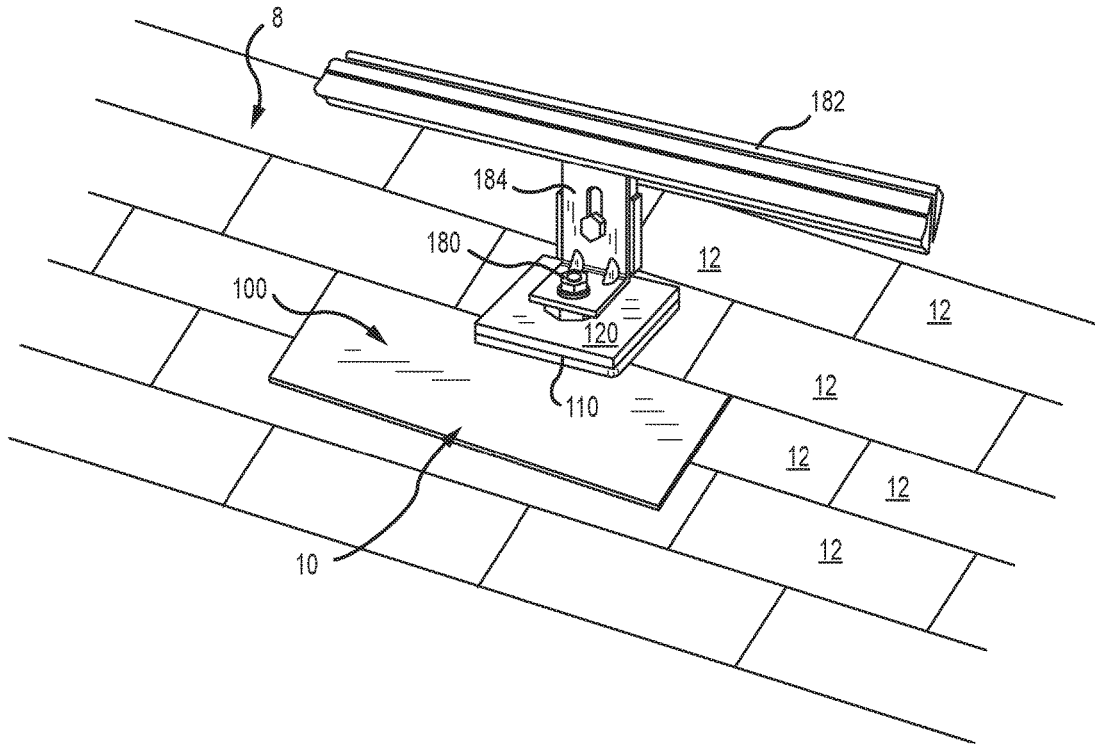

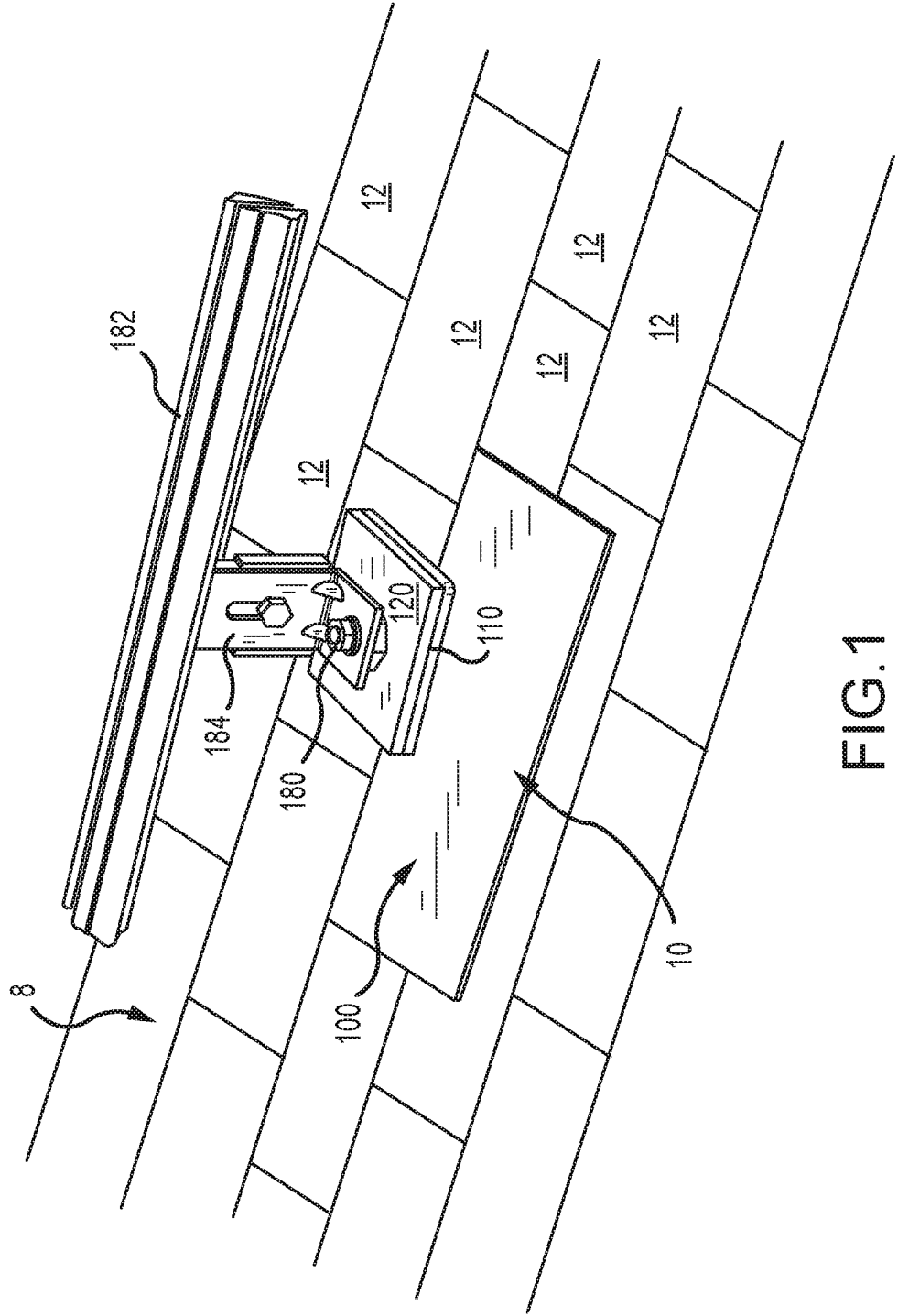

FIG.1

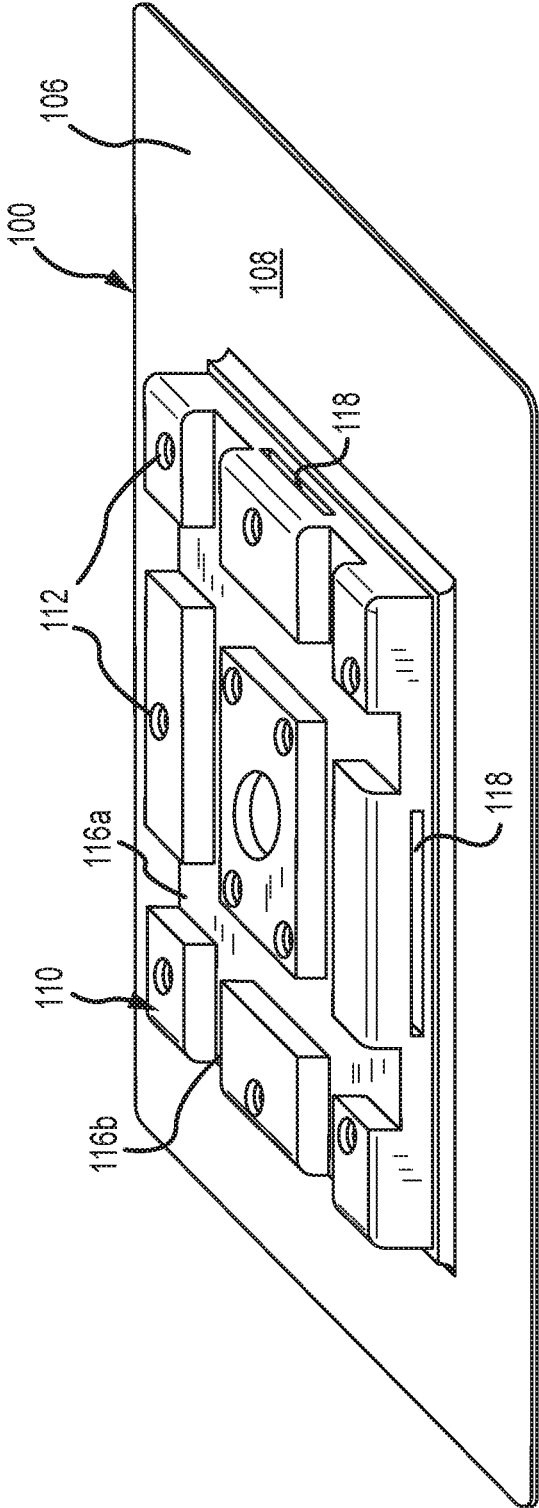

FIG. 2A

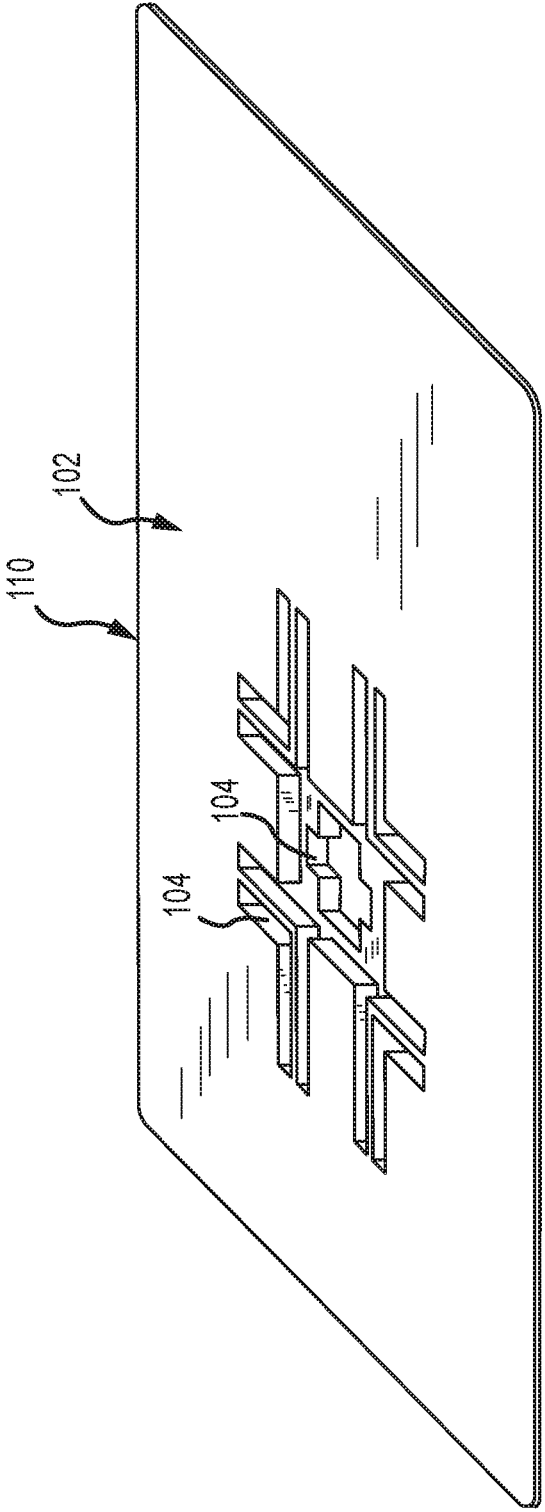

FIG. 2B

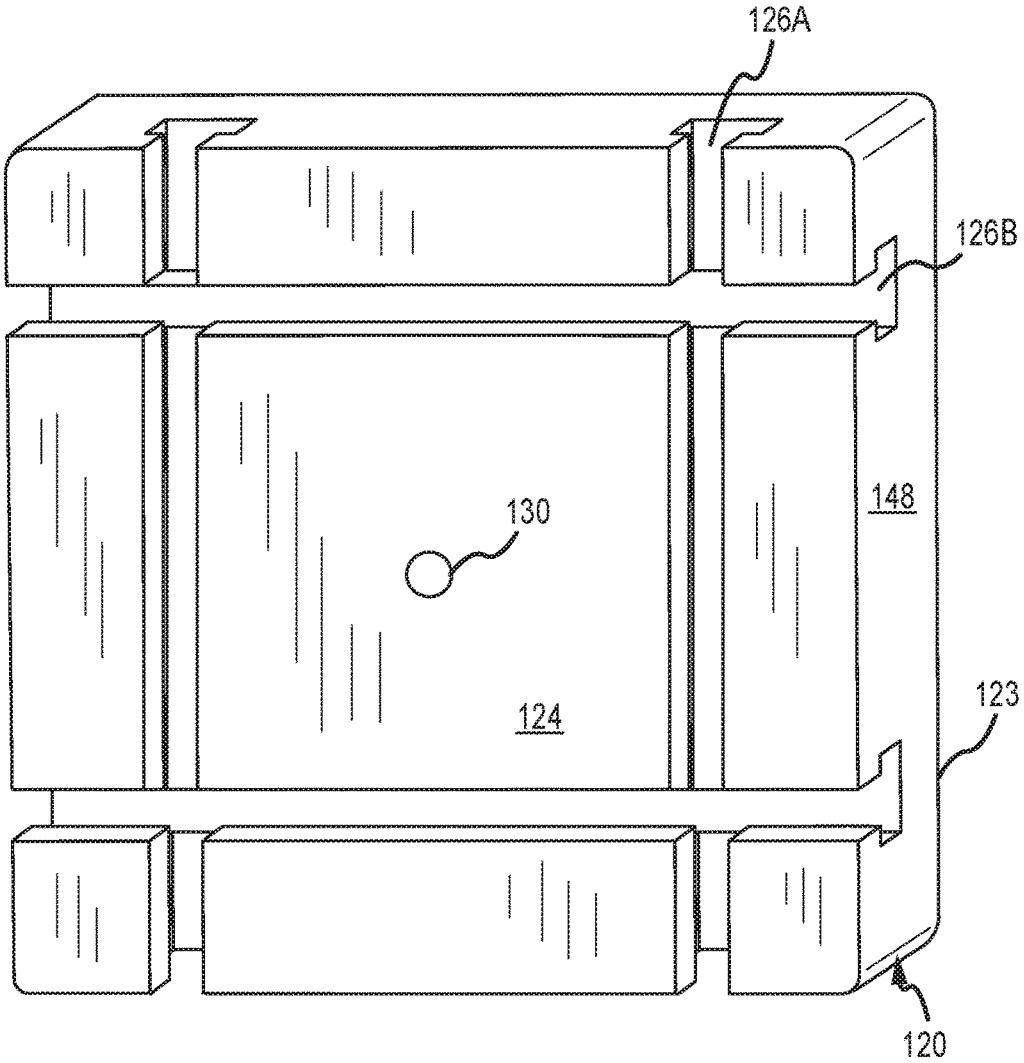

FIG.3A

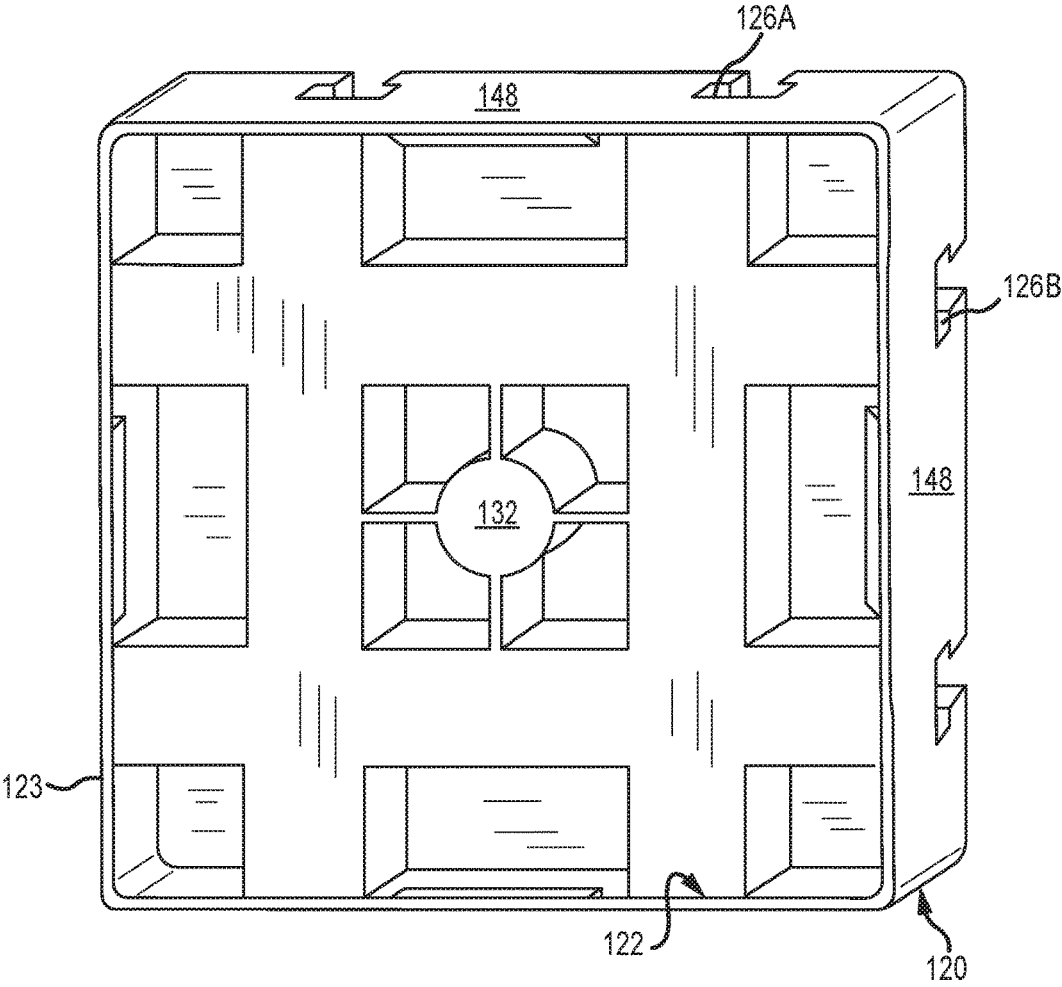

FIG. 3B

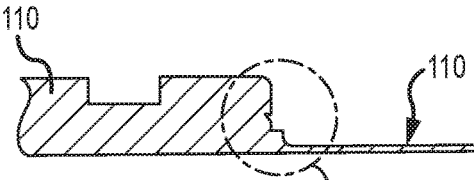

FIG. 4A

FIG. 4B

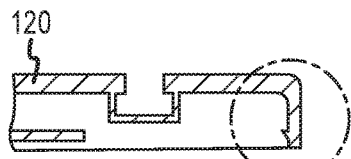

FIG. 4C

FIG. 4D

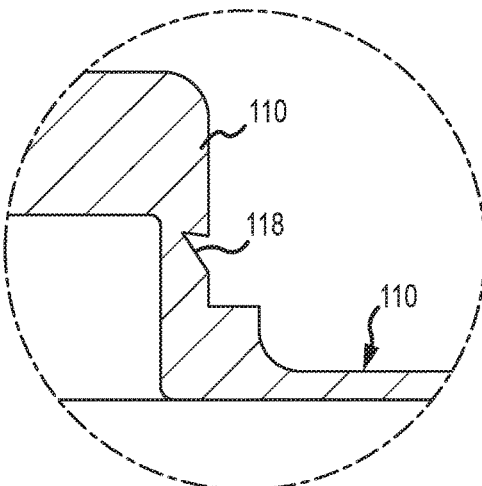

FIG. 4B

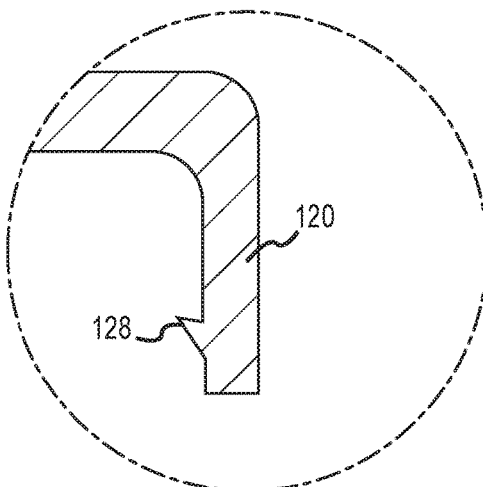

FIG. 4D

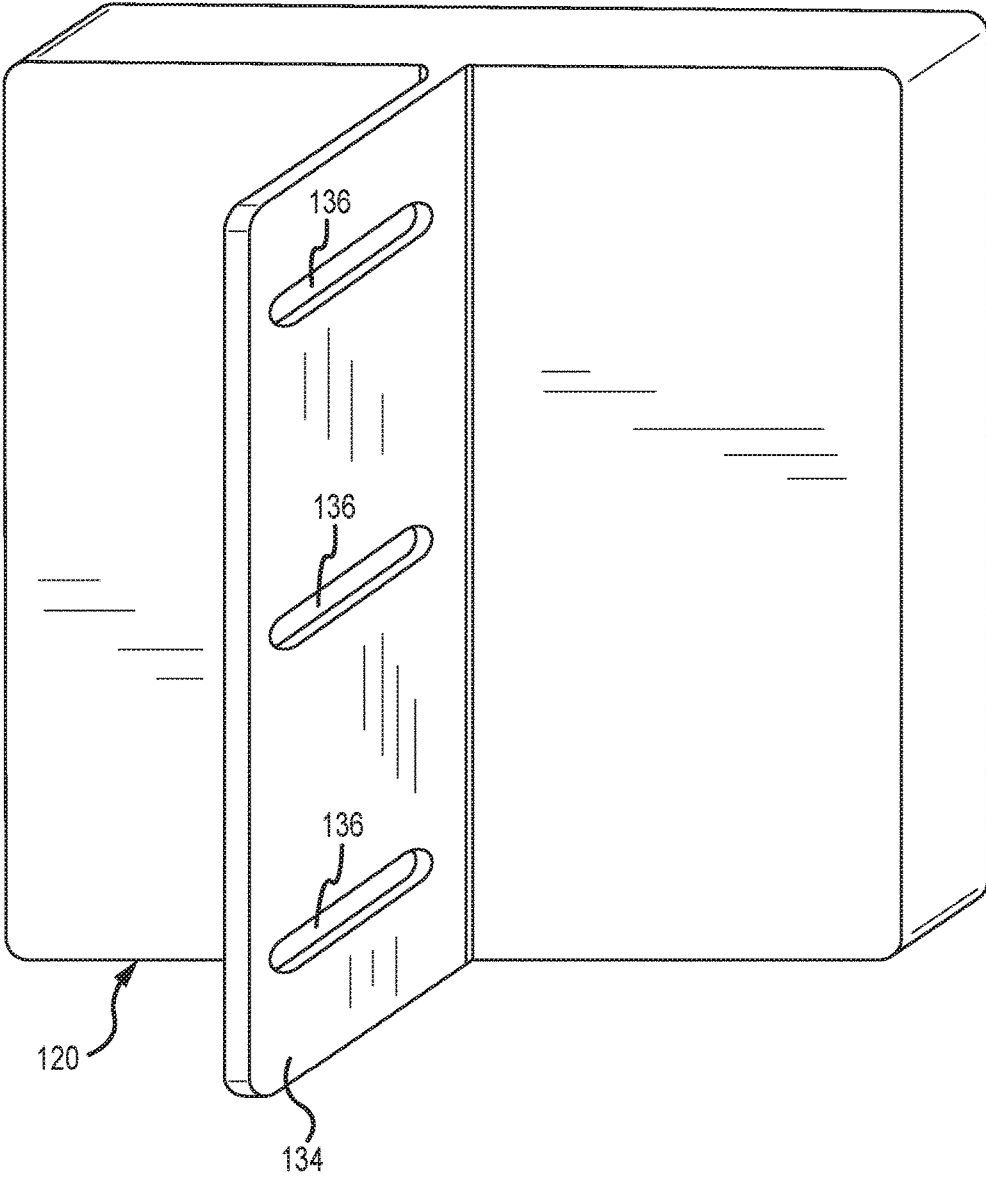

FIG.5

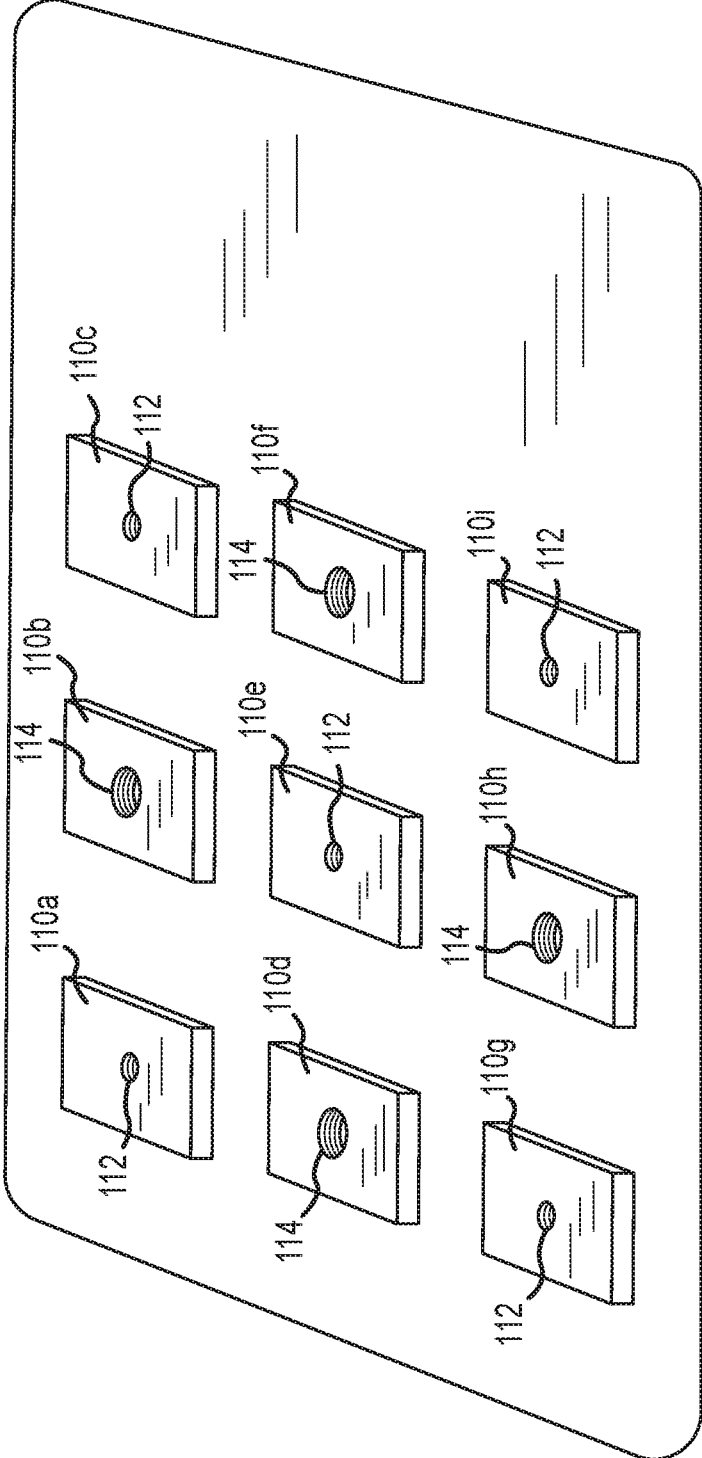

FIG.6A

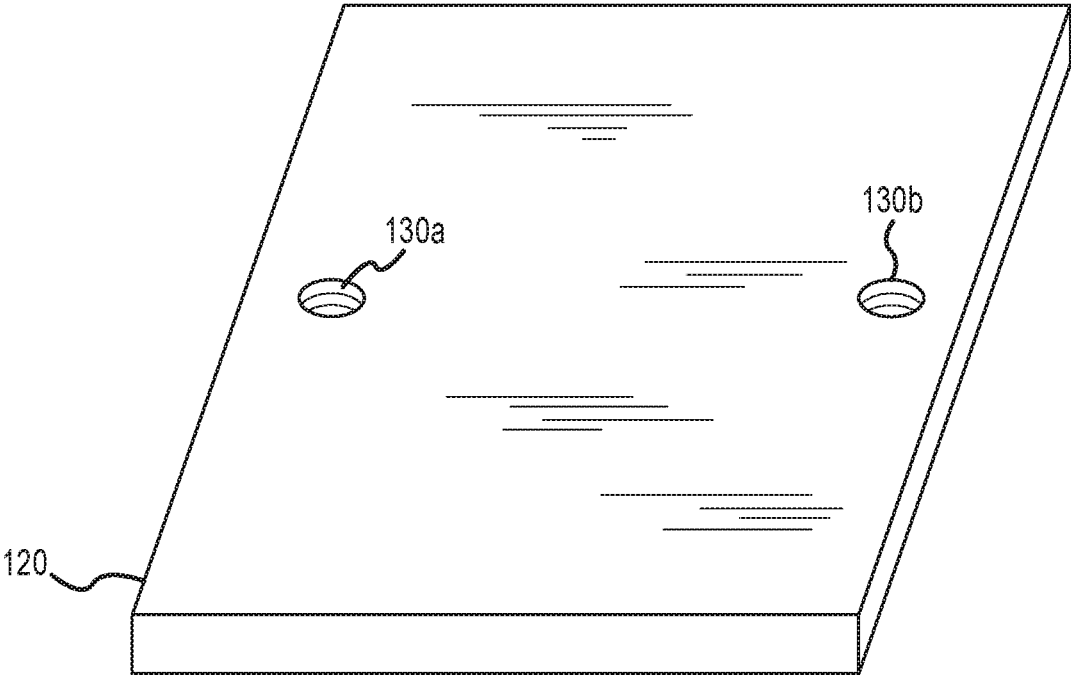

FIG.6B

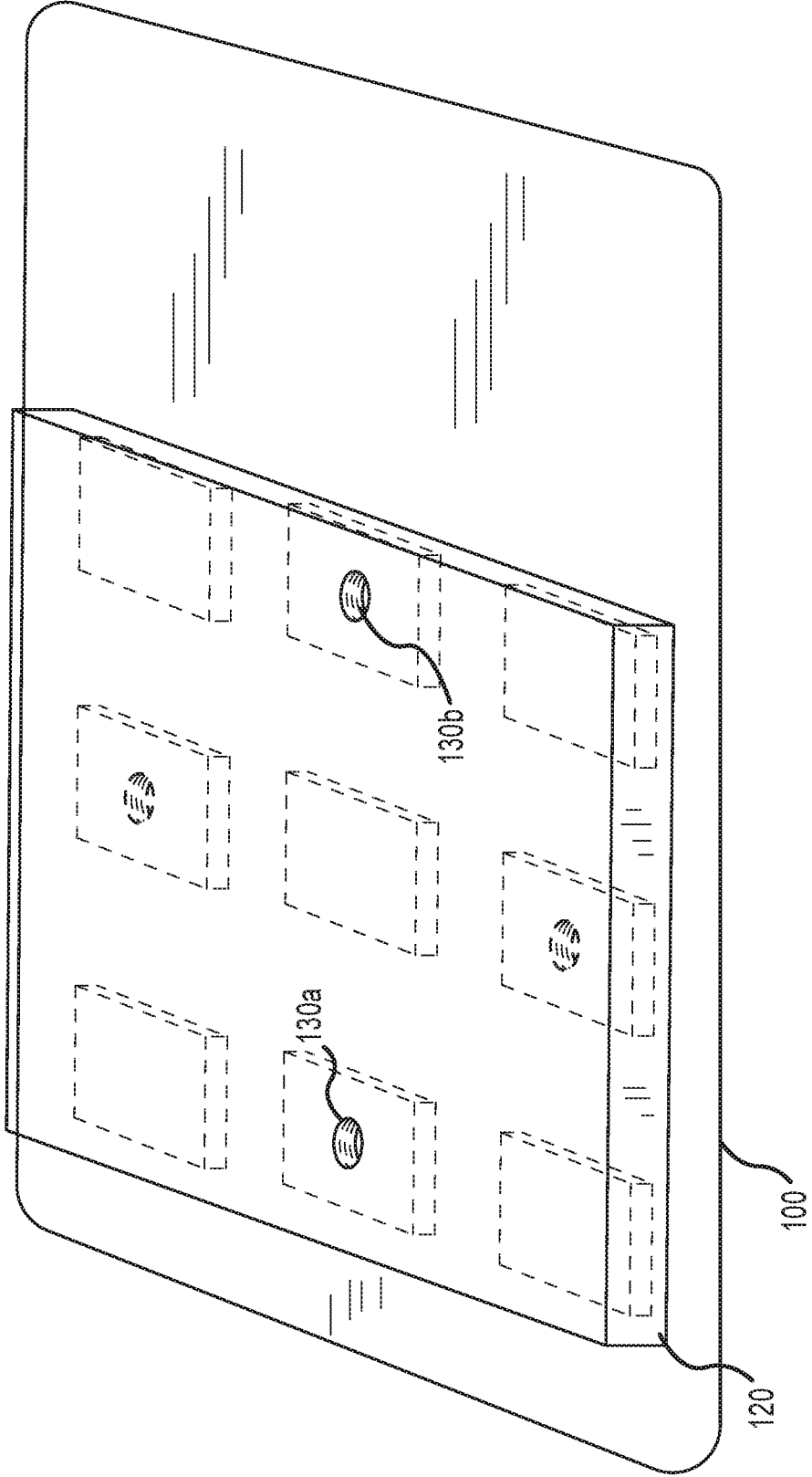

FIG. 6C

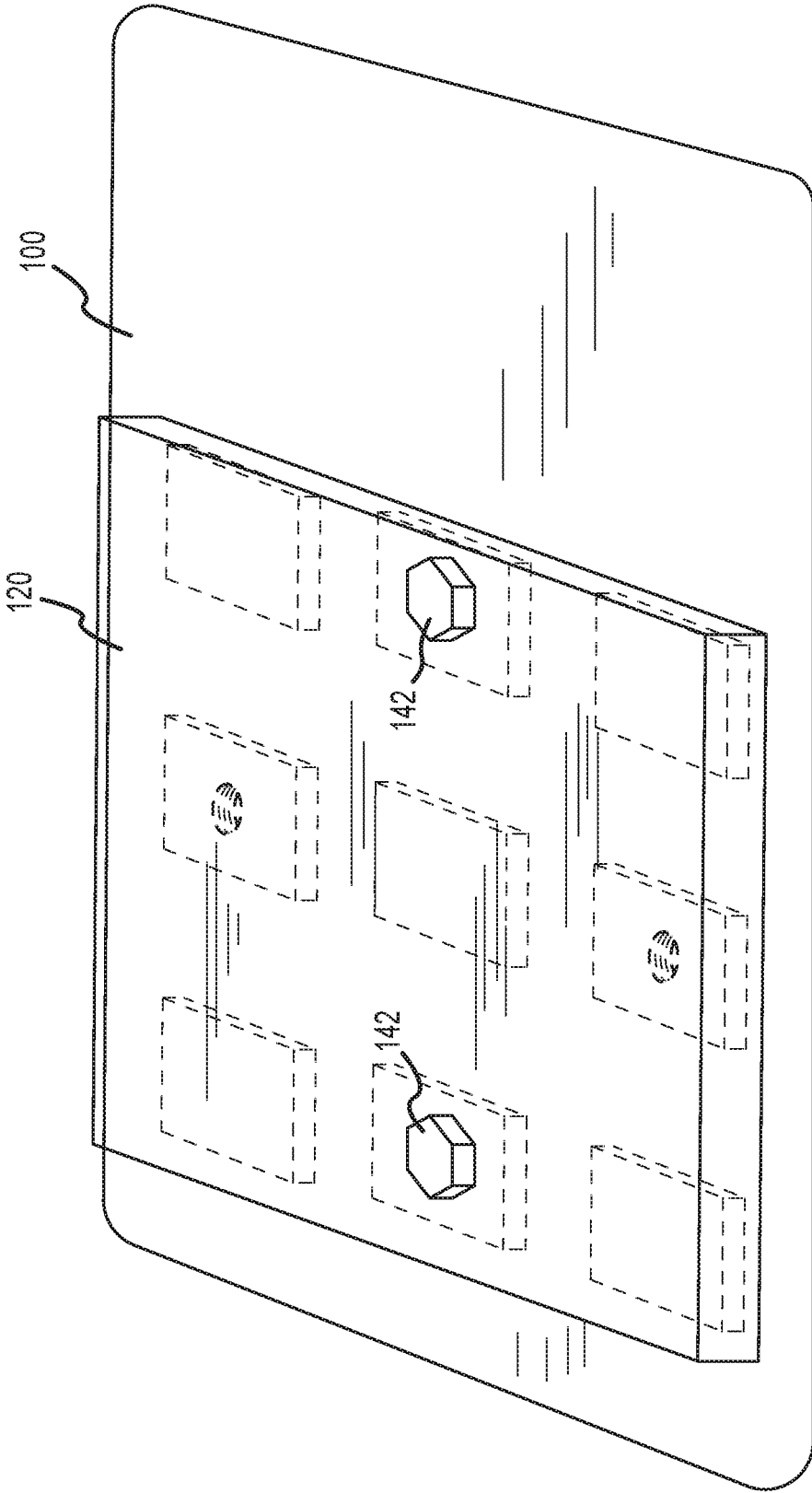

FIG. 6D

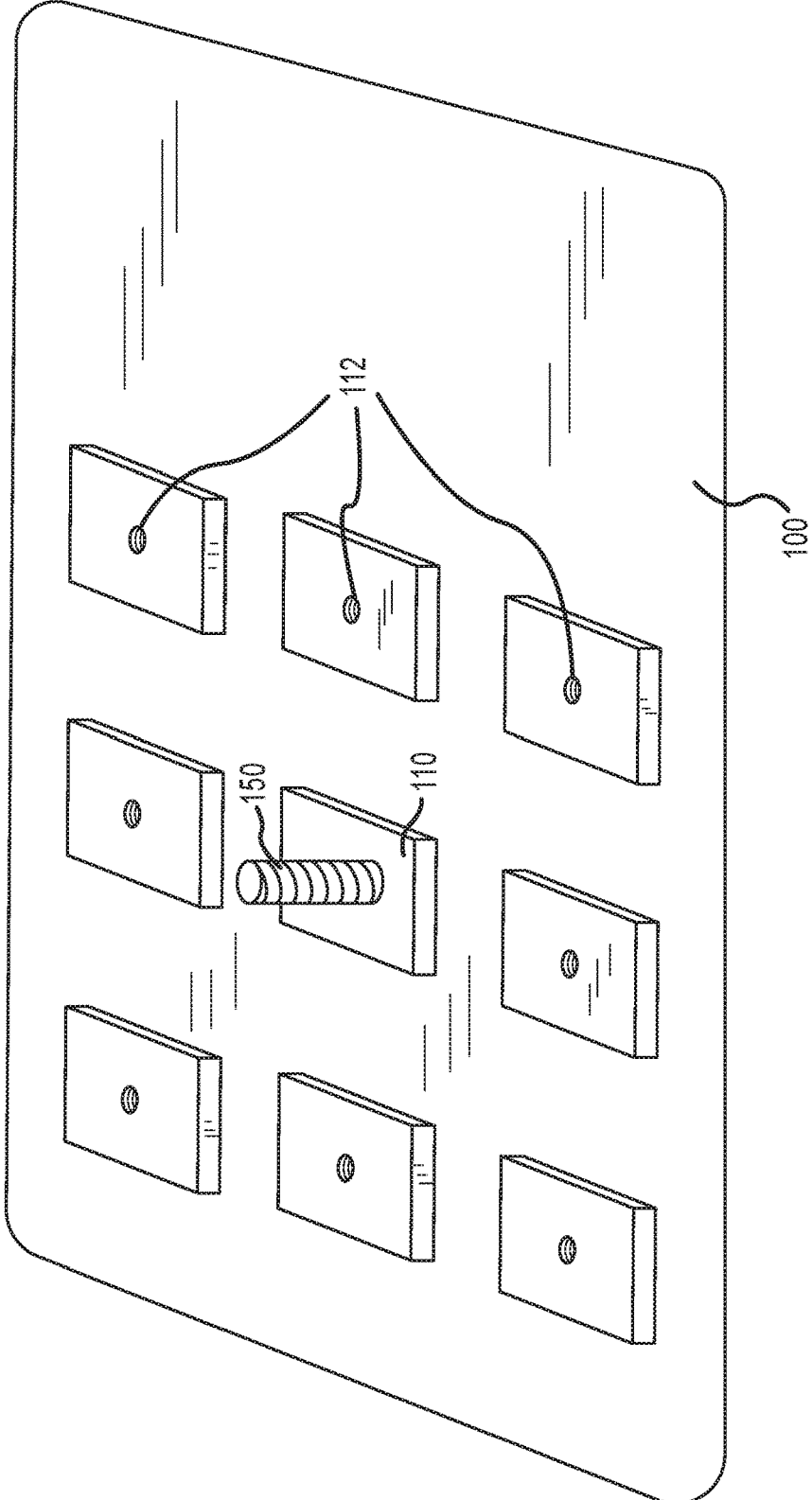

FIG.7A

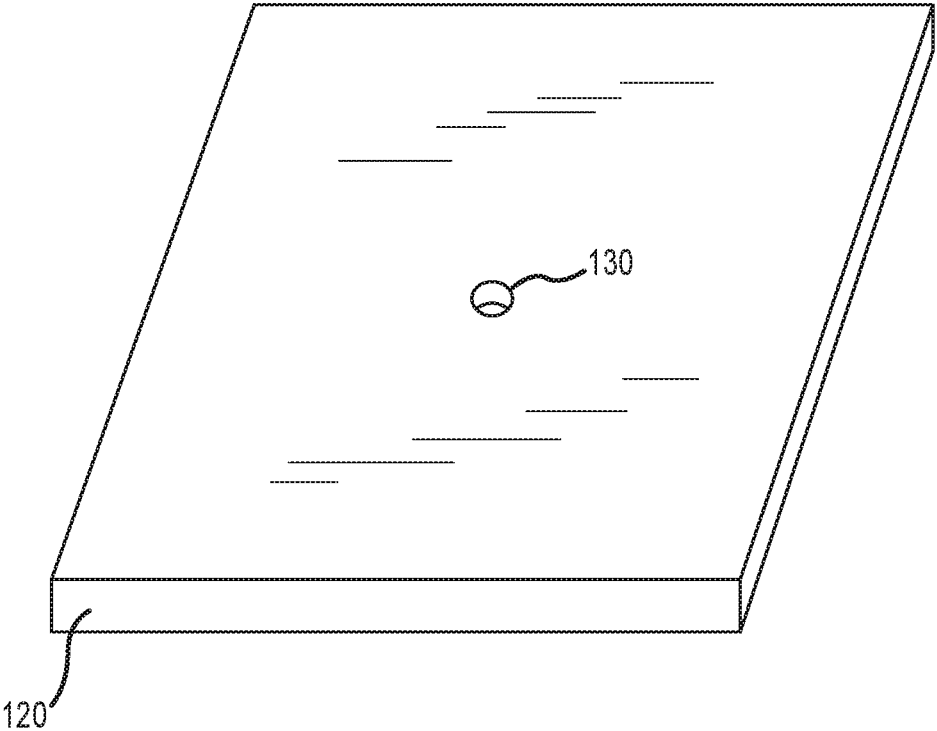

FIG.7B

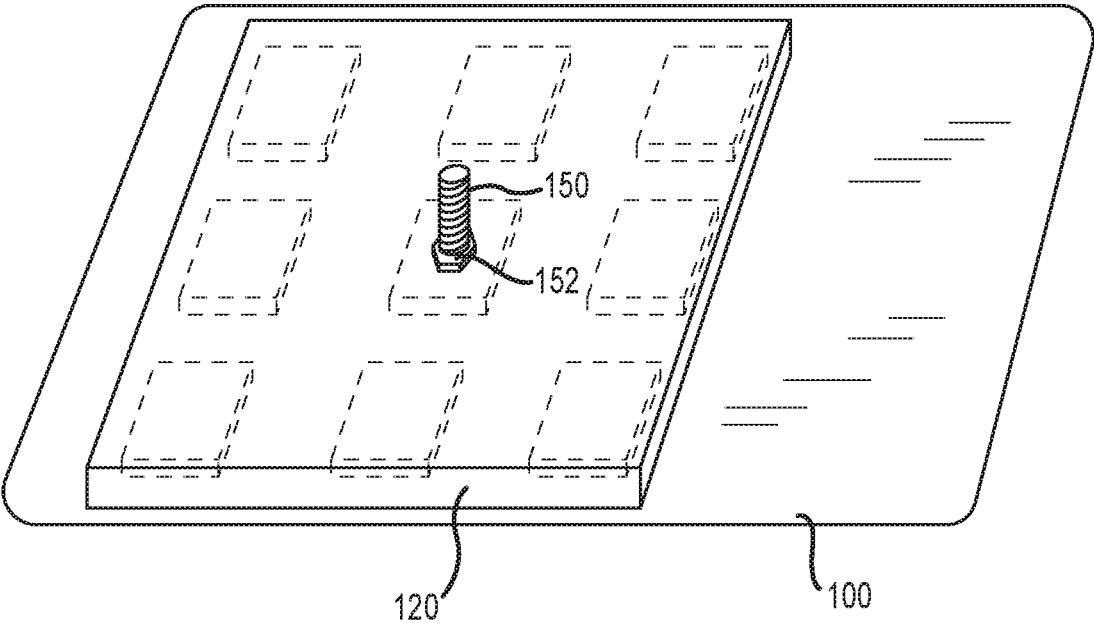

FIG.7C

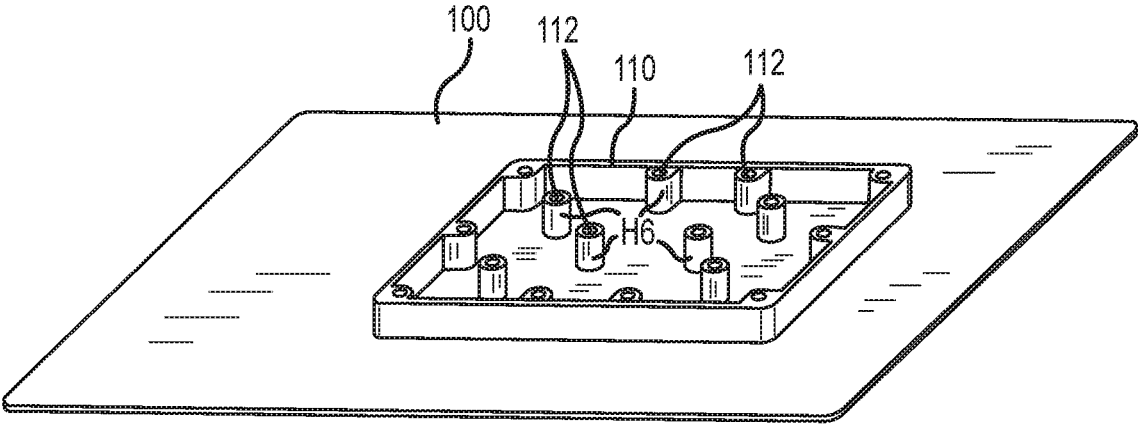

FIG. 8A

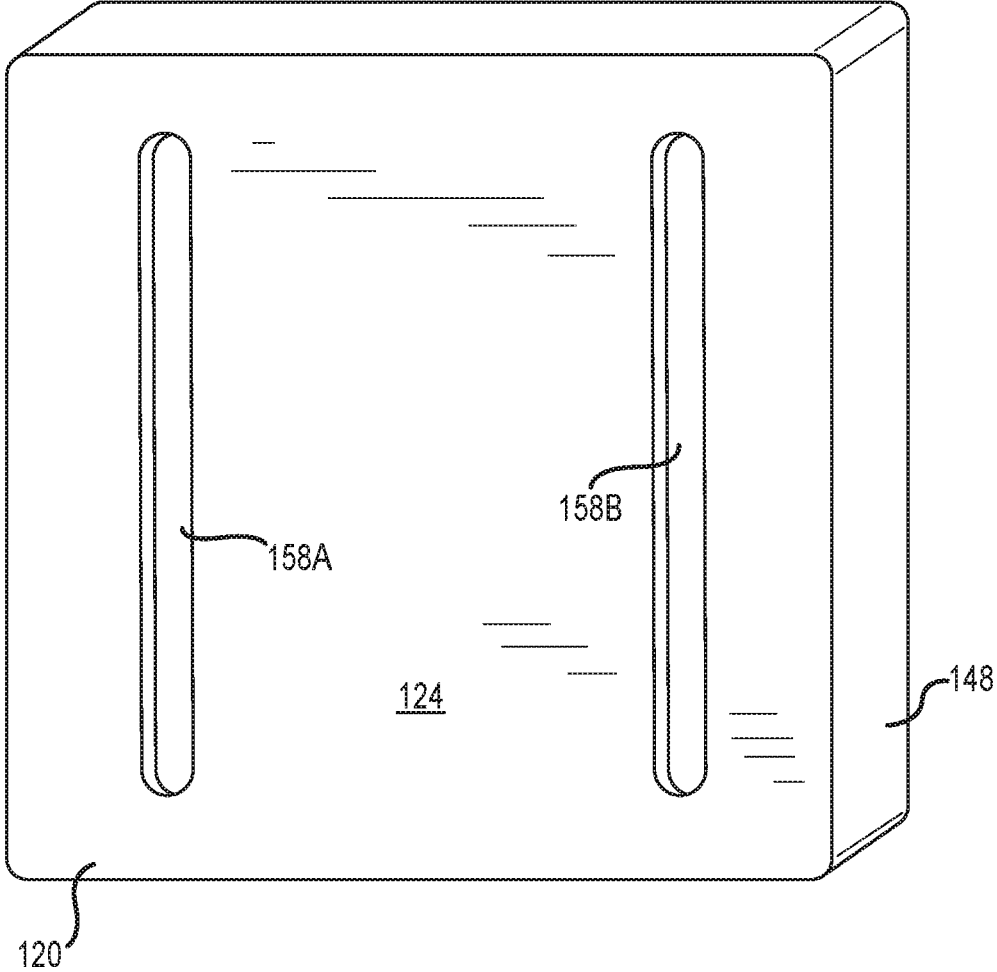

FIG. 8B

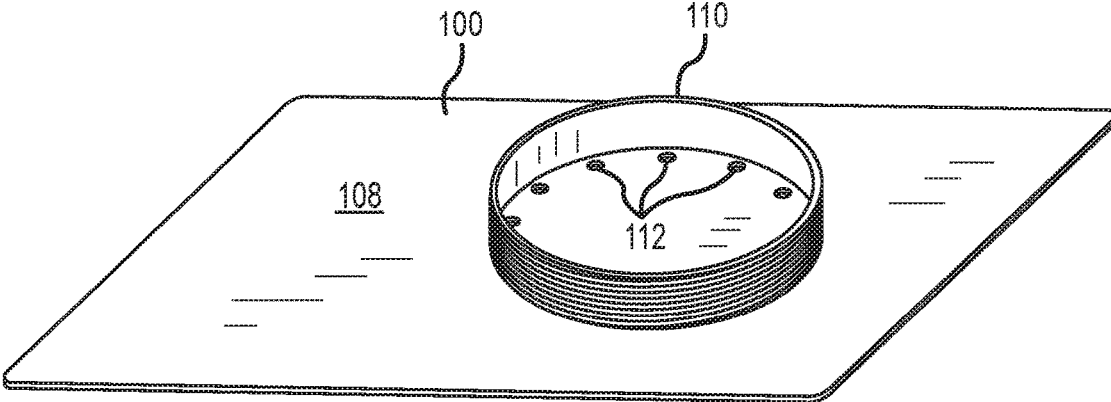

FIG.9A

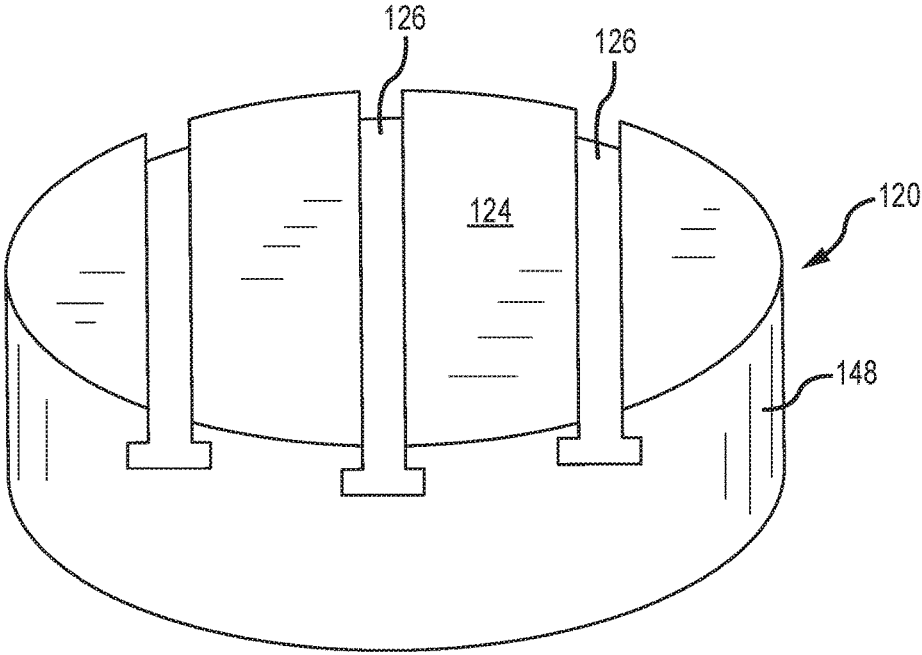

FIG. 9B

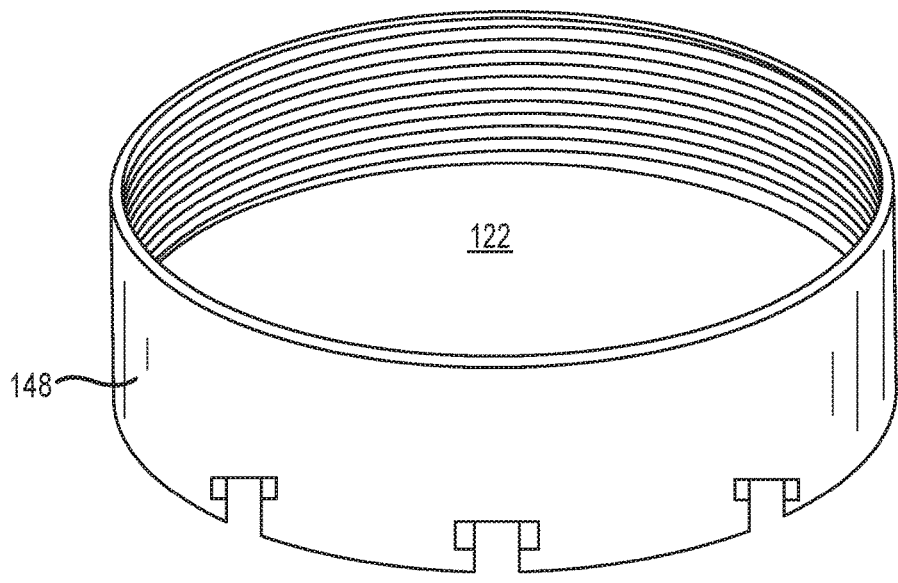

FIG. 9C

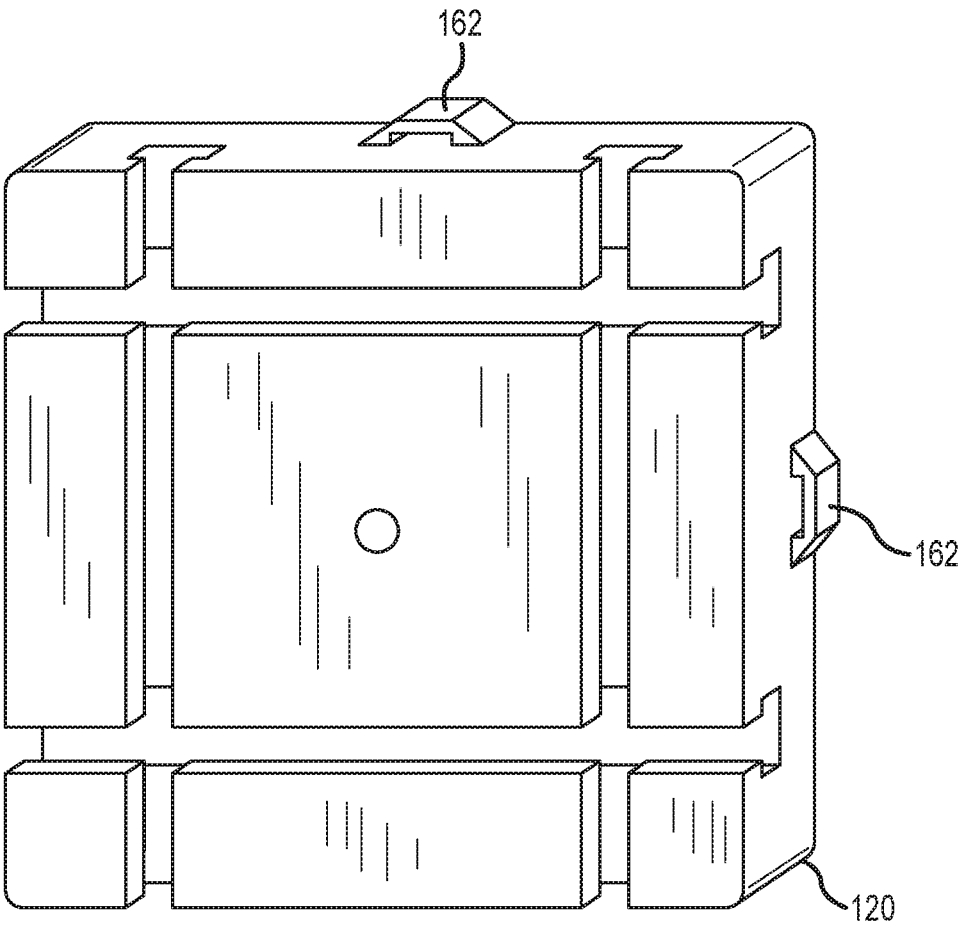

FIG.10

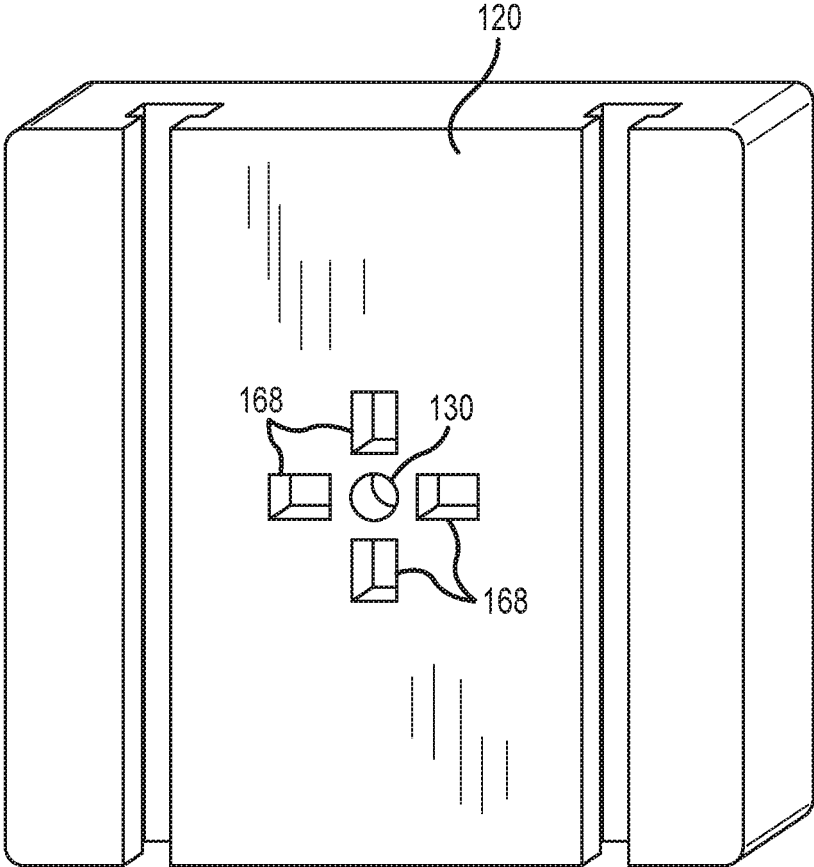

FIG. 11A

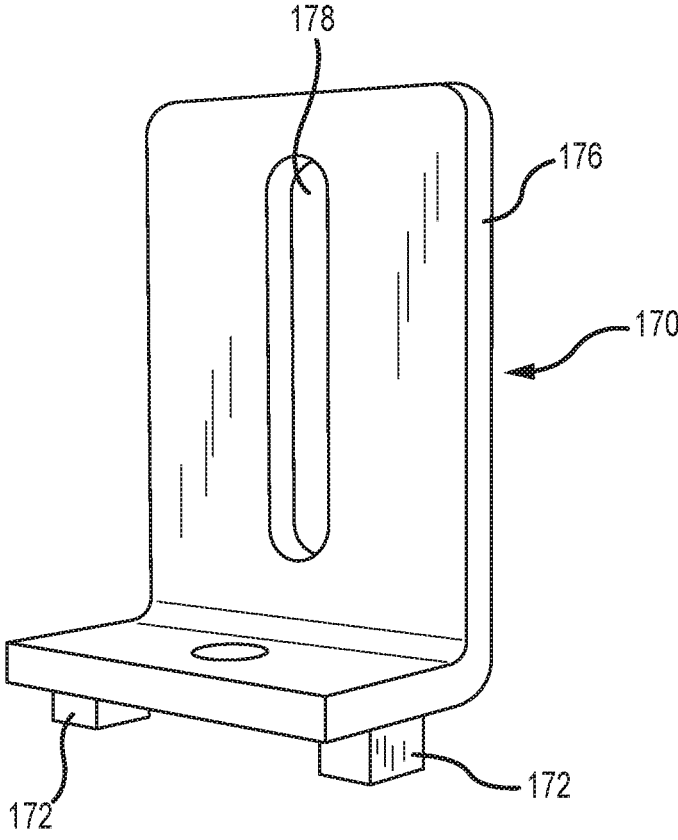

FIG. 11B

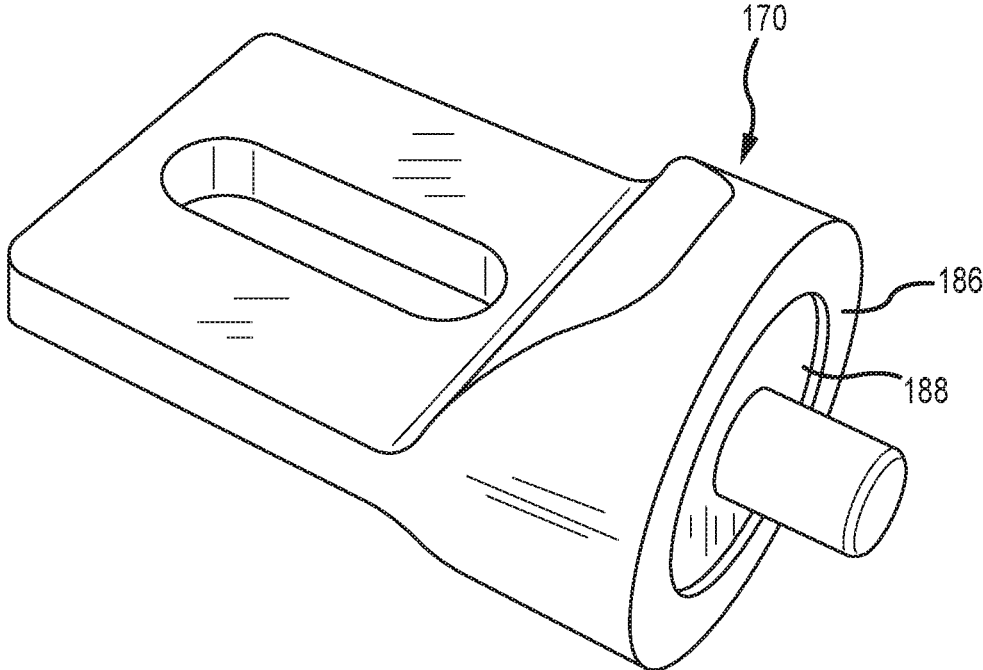

FIG.12

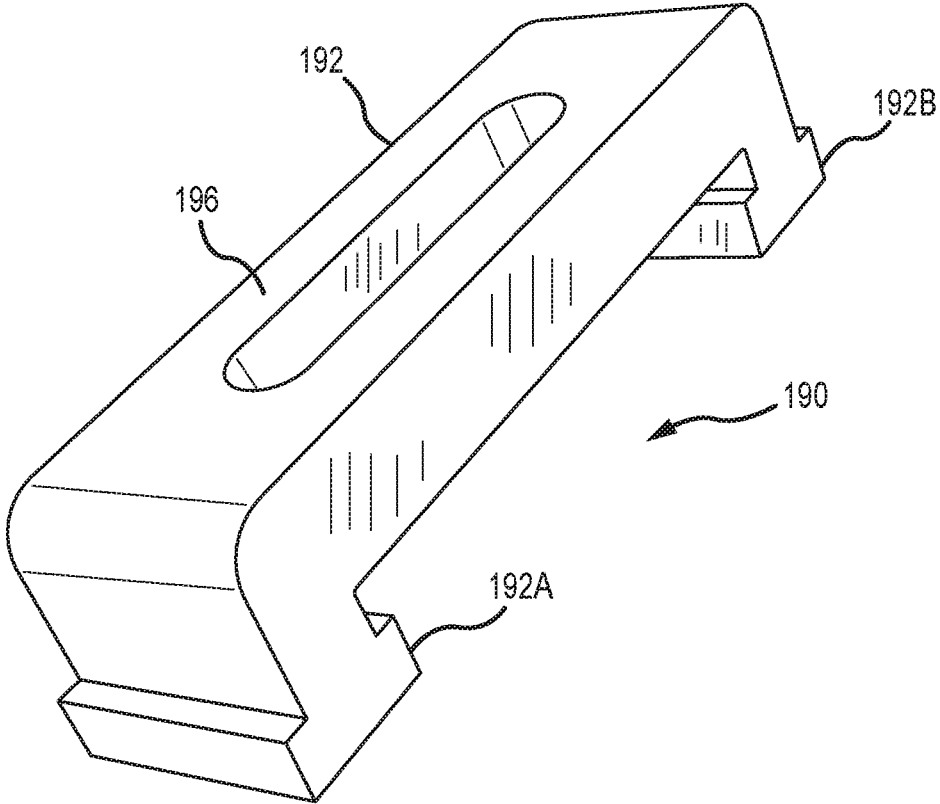

FIG. 13

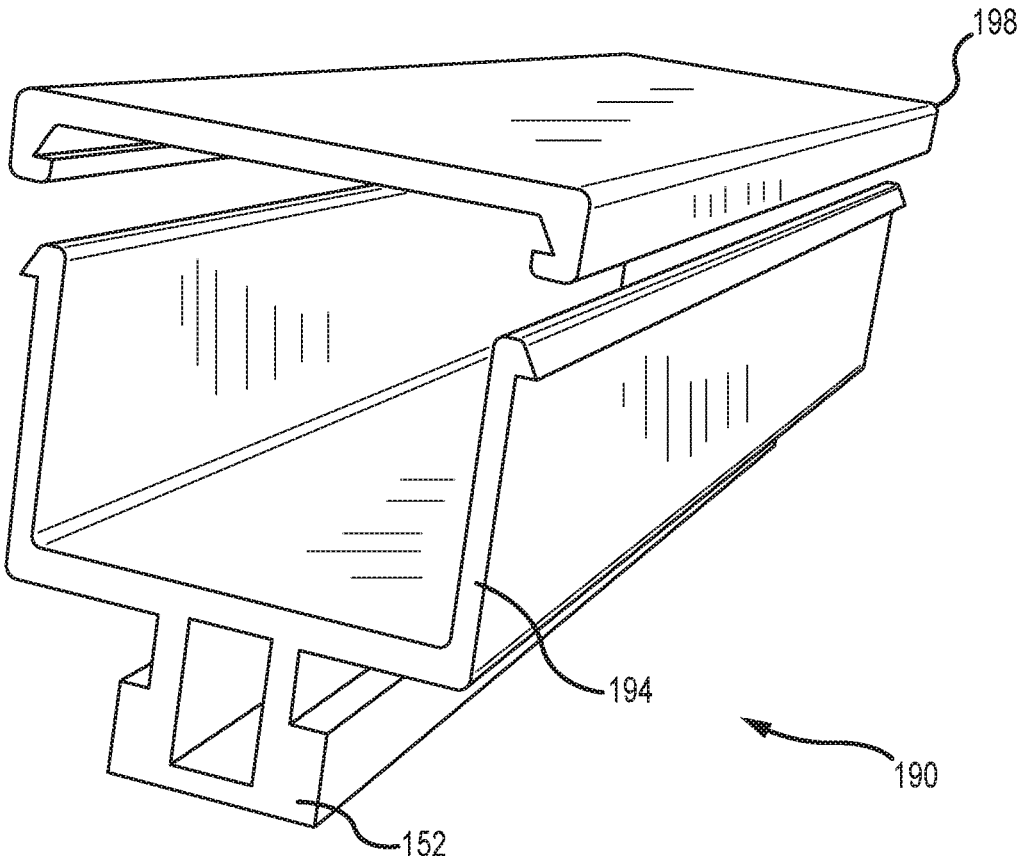

FIG. 14

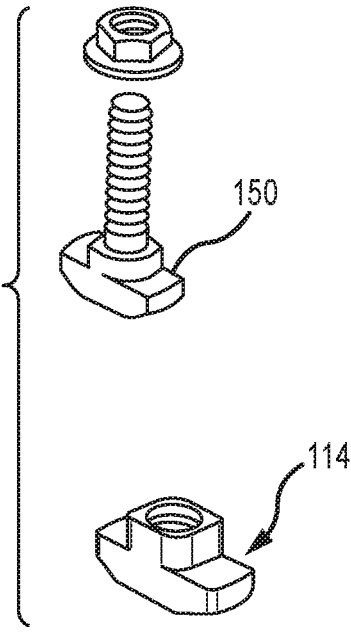

FIG. 15

**ADJUSTABLE COMBINED FLASHING AND
MOUNTING APPARATUS AND METHOD OF
MOUNTING TO BE USED THEREWITH**

CROSS REFERENCE

[0001] The present application claims the benefit of the filing date of U.S. Non-Provisional application Ser. No. 14/608,569 having a filing date of Jan. 29, 2015, which claims benefit of U.S. Provisional Application No. 61/933,004 having a filing date of Jan. 29, 2014, the entire contents of which is incorporated herein by reference.

BACKGROUND

[0002] Many systems exist to mount various devices on roof tops and similar locations. One common device to mount on roofs is solar panels, particularly photovoltaic (PV) solar panels. Currently, to mount PV solar panels or other similar devices, rack systems are generally used. Due to the weight and attachment mechanism used with these rack systems, the attachment to the roof is typically into structural members. This requires that the roof framing be located beneath the shingles. The location of the rafters dictates the location and therefore spacing of the racking system, or at least its anchor points. Further, the installation can be made more difficult by unevenly spaced rafters and/or ones that are not strait and/or parallel or structures with no rafters, or purlins, such as stress skin panel installations. Additionally, the rails add significantly to the total height and weight of the system and to the cost of the installation.

[0003] The foregoing example of the related art and limitations related therewith are intended to be illustrative and not exclusive. Other limitations of the related art will become apparent to those of skill in the art upon a reading of the specification and a study of the drawings.

SUMMARY

[0004] One aspect of the present disclosure is a roof mounting system for PV panels and other devices that does not require rails, but allows the use of rails if desired.

[0005] One aspect of the present disclosure is a roof mounting system that can be mounted on to locations other than a rafter.

[0006] Another aspect of the present disclosure is a mounting system that allow attachment of a PV panel along different locations in at least two directions.

[0007] Another aspect of the present disclosure is a roof mounting system that reduces or prevents water leakage.

[0008] In one aspect, the present disclosure is directed to a roof mounting system that utilizes a base plate that is affixed to a roof surface by multiple fasteners (e.g., lag bolts, screws etc.) and a cap (e.g., top cap) that attaches to the base plate covering the fasteners affixing the base plate to the roof surface. Once attached, the top cap covers the fasteners preventing water infiltration. To further waterproof the fasteners affixing the base plate to the roof surface, the base plate includes a raised or elevated section on its top surface. Typically, a planar flange extends around the elevated section. A portion of the flange may be disposed beneath a single or shingles on a roof surface. Most commonly, the fasteners extend through the elevated section such that the heads of the fasteners are disposed above the surface of the flange. In this regard, water drains around the elevated section when the base plate is attached to a roof surface

further isolating the fasteners extending through the base plate. In one arrangement, the elevated section includes a plurality of fastener recesses that extend at least partially through the base plate. Once fasteners affix the base plate to the roof surface, the top cap is attached to the base plate using a fastener. In one arrangement, a bottom surface of the top cap is recessed and sized to receive the elevated section of the base plate. In such an arrangement, a periphery of the recessed bottom surface of the top cap may fit around the periphery of the elevated section. In any arrangement, once the top cap is fastened/affixed to the base plate, objects may be attached to an attachment structure of the top cap and/or base plate.

[0009] The base plate may have any geometric configuration. Typically, the base plate is generally rectangular having a planar bottom surface. However, other shapes are possible and considered within the scope of the present disclosure. In one arrangement, the elevated section is disposed within a periphery of the top surface of the base plate such that the portion of the base plate that extends beyond the elevated section forms a flange. In various arrangements, one end of the flange may be longer than other portions of the flange to allow for its placement beneath a roof shingle(s).

[0010] In one arrangement, the fastener comprises a snap fit arrangement between the elevated section of the base plate and the top cap. In such an arrangement, an inside periphery of the recessed bottom surface of the top cap may include detents or spring tabs and the outside periphery of the elevated section may include mating spring tabs or detents. In another arrangement, the base plate may include one or more threaded fasteners. Such threaded fasteners may be female fasteners (e.g., nuts) or male threaded fasteners (e.g., studs) that are affixed within the base plate. In such an arrangement the top cap may include apertures that align with the threaded fasteners in the base plate. Accordingly, mating fasteners may extend through the top cap and into the base plate to affix the top cap to the base plate. In addition, such fasteners may be utilized to affix objects (e.g., brackets, flanges etc.) to the top cap. In another arrangement, the elevated section and top cap may be substantially circular. In this arrangement an outside periphery of the elevated section may have threads and inside periphery of the recessed surface of the top cap may have mating threads. In this arrangement, the top cap may be threaded onto the elevated section. Such an arrangement may provide height adjustment for the top cap.

[0011] In one arrangement, one or more fastener recesses are formed within the interior periphery of the elevated section. Such fastener recesses may extend at least partially through the base plate. Such fastener recesses are, in one embodiment, non-aligned. That is, such fastener recesses may not be aligned perpendicular to an edge of the base plate. This may prevent insertion of multiple fasteners into a seam between sheathing on a roof surface.

[0012] In any arrangement, the roof mounting system includes a structure for attaching a component or object to the top cap. In one arrangement, the top cap includes a projection integrally formed on its surface. For instance, the top cap may include an integrally formed flange having one or more apertures for attaching an object thereto. In another arrangement, the top cap may include one or more apertures for threading an object (e.g., bolt) directly into the top cap. Alternatively, the top cap may have one or more apertures

that permit threading object into or onto a threaded element in the base plate. Most typically, an object attached to the top cap or base plate via a threaded fastener will not thread directly into the roof surface. However, this is not a requirement.

[0013] In one arrangement, the elevated section of the base plate includes one or more recessed channels. These channels may extend in a common direction or intersect. In this arrangement, the top cap may also include one or more mating recessed channels. These channels may have an overhanging lip that allows for maintaining an object within the channel. For instance, in cross-section such channels in the top cap may have an inverted T-shape or an L-shape. That is, a closed bottom end of the channel may be wider than an open upper end of the channel.

[0014] The following embodiments and aspects thereof are described and illustrated in conjunction with systems, tool and methods which are meant to be exemplary and illustrative, not limiting in scope. In various embodiments, one or more of the above described problems have been reduced or eliminated, while other embodiments are directed to other improvements.

[0015] In addition to the exemplary aspects and embodiments described above, further aspects and embodiments will become apparent by reference to the accompanying drawings forming a part of this specification wherein like reference characters designate corresponding parts in the several views.

BRIEF DESCRIPTION OF THE DRAWINGS

[0016] Before explaining the disclosed embodiment of the present invention in detail, it is to be understood that the invention is not limited in its application to the details of the particular arrangement shown, since the invention is capable of other embodiments. Exemplary embodiments are illustrated in referenced figures of the drawings. It is intended that the embodiments and figures disclosed herein are to be considered illustrative rather than limiting. Also, the terminology used herein is for the purpose of description and not of limitation.

[0017] FIG. 1 illustrates a roof mounting system.

[0018] FIGS. 2A and 2B illustrate top and bottom views of one embodiment of a base plate of a roof mounting system.

[0019] FIGS. 3A and 3B illustrate top and bottom views of one embodiment of a top cap of a roof mounting system.

[0020] FIGS. 4A-4D illustrate one embodiment of a fastener between a base plate and top cap of a roof mount system.

[0021] FIG. 5 illustrates another embodiment of a top cap of a roof mount system.

[0022] FIGS. 6A-6D illustrate another embodiment of a roof mount system.

[0023] FIGS. 7A-7C illustrate another embodiment of a roof mount system.

[0024] FIGS. 8A and 8B illustrate another embodiment of a roof mount system.

[0025] FIGS. 9A-9C illustrate another embodiment of a roof mount system.

[0026] FIG. 10 illustrates another embodiment of a top cap of a roof mount system.

[0027] FIG. 11A illustrates another embodiment of a top cap of a roof mount system.

[0028] FIG. 11B illustrated one embodiment of an attachment element.

[0029] FIG. 12 illustrated one embodiment of an attachment element.

[0030] FIG. 13 illustrated another embodiment of an attachment element.

[0031] FIG. 14 illustrated another embodiment of an attachment element.

[0032] FIG. 15 illustrates T-bolts and T-nuts for use with the mounting system.

DETAILED DESCRIPTION

[0033] All references to horizontal and vertical contained herein are references to the orientation of the items in the drawings. No limitation should be inferred as to the actual orientation of the items in use.

[0034] In a number of applications, it is desirable to mount one or more structures to a roof surface. For instance, photovoltaic solar cells are often mounted to the roof of a residence or other structure. Typically, mounting feet or bases (e.g., mounting systems) are attached to the surface of the roof to provide an anchor point for the structures to be attached to the roofing surface. Previously, such systems required attachment to underlying structures in the roofing surface. For instance, in residential construction, wooden sheathing is often applied over structural rafters. In order to provide necessary pullout strength for a photovoltaic cell, previous systems have required that the mounting bases of the mounting systems to be affixed to the rafters. Typically, such mounting bases are attached utilizing bolts such as lag screws which extend through the base and into the underlying rafters. In the case of photovoltaic cells, pullout strength and compression loading strength is a function of the size of the individual solar cells. That is, wind loading and compression loading (e.g., snow loading) requirements have dictated that mounting bases be attached to underlying rafters. Such requirements are commonly dictated by local or regional building codes.

[0035] The presented roof mounting systems are designed in a manner that allows for attaching a mounting base to sheathing of the structure without necessarily requiring attachment to the underlying structural supports/rafters. That is, the presented roof mounting systems provide pullout and compression loading that exceeds code requirements without requiring attachment to underlying rafters. This allows the roof mounting systems to be applied to a roof surface without regard to the location of underlying structural members. Stated otherwise, the roof mounting systems may be located anywhere on a roof surface including between rafters. In this regard, the presented roof mounting systems allow for more readily laying out a set of roof mounts and more quickly attaching these to a roof surface.

[0036] FIG. 1 illustrates one exemplary embodiment of a roof mounting system **10** that may be affixed to a roof surface to provide a mount for attaching structures (e.g., PV panels) to the roof surface. Generally, the roof mounting system includes a base plate **100** that rests on the roof surface **8**. Fasteners, such as screws, lag bolts etc. (not shown) extend through a raised section **110** of the base plate **100** to affix the base plate to the roof surface. The raised section is disposed within the periphery of a generally flat or planar flange **108**, which may, in some applications, be partially disposed beneath shingles **12** on the roof surface **8**. In the illustrated embodiment, the raised section **110** is at least partially covered by a top cap **120**. The top cap **120** covers the fasteners that pass through the raised section and

extend into the roof surface **8**. In this regard, the top cap **120** prevents water from passing through the base plate **110** at the locations where the fasteners that pass the base plate **110** and into the roof surface **8**. Once the base plate **110** and top cap **120** are connected, one or more fasteners **180** may be connected to the top cap **120** and/or the base plate to attach objects, such as a support rail **182** to the roof surface **8**. Further, various brackets **184** may be utilized to connect the object **182** to the top cap **120** and/or base plate **110**.

[0037] FIGS. 2A and 2B illustrate top and bottom views of one embodiment of a base plate **100** of the roof mounting system **10**. As shown, the base plate **100** has a substantially planar bottom surface **102** that is adapted for placement on a roof surface. The bottom surface **102**, though generally planar, may include various recesses **104** for weight reduction purposes and/or to secure, for example, T-bolts and T-nuts while preventing their rotation, as further discussed herein. The top surface **106** includes one or more raised sections **110** that extend above a generally planar peripheral portion or flange **108**. As shown, the flange **108** extends beyond the base of the raised section **110** in all directions. One end of the flange **108** is typically longer than the opposing end such that the long end may be disposed beneath a course of shingles **12**. When applied to the roofing surface, the outside edges of the bottom surface of the base plate **100** may include a bead of caulk or other sealing material. Placement of the long end of the flange **108** below shingles allows the base plate to shed water. Further, the base plate is an integral structure. That is, the raised section **110** and the flange **108** are a single piece. This prevents any water from seeping between the raised sections and the flange further isolating the fasteners. In one embodiment, the base plate **100** is an injection molded. In such an embodiment, the base plate may be polymeric. However, it will be appreciated that the base plate may be made using other processes and materials.

[0038] As noted, the raised section **110** is disposed within the interior of the periphery of the flange **108** on the base plate's top surface. The raised section **110** includes a plurality of fastener ports or recesses **112**. These fastener recesses **112** are spaced throughout the raised section(s) **110** and preferably only extend a portion of the way through the raised section **110** towards the bottom surface **104** of the base plate **100**. In use, an installer may insert a screw or other fastener into the fastener recesses **112** and driving these fasteners through the bottom surface **104** of the base plate **100** and into a roof surface. As the bottom ends of the fastener recesses **112** are preferably closed, there is no penetration through the base plate **100** if one of the fastener recesses does not receive a fastener. Further, as the fastener recesses **112** are disposed in the raised section(s) **110**, water on the surface of the base plate is isolated from the fasteners. That is, the base plate is typically disposed on an angled roof surface and water sheds around the raised section(s). Thus water running down the roof surface is prevented from entering into the fastener recesses **112**.

[0039] The size of the base plate is such that it is able to distribute weight over the roofing surface to an extent that allows adequate compression strength when applied to sheathing free of underlying structural supports (e.g., between rafters). In one arrangement, the raised section of the base plate is approximately 6"x6". However, this is not a requirement. In such an arrangement, the flange may extend 2-4 inches beyond the edge of the raised section on three sides and about 4-8 inches beyond the raised section on

the edge that fits beneath the shingles. Again, variations may be made. However, it has been determined that the base plate of this size will provide enough surface area to provide sufficient compression strength when mounted between rafters while complying with most building codes.

[0040] In the illustrated embodiment, the raised section includes twelve fastener recesses **112**. Use of such a large number of fastener recesses allows the roof mounting system to have a pull out strength that meets or exceeds most building codes. In one arrangement, the fastener recesses **112** are nonaligned. That is, each fastener recess is slightly offset from an adjacent fastener recess; each row or column of fastener recesses is non-perpendicular to an edge of the base plate **100**. In this regard, if one of the fastener recesses is disposed directly above a seam between two sheathing members, only a single fastener is inserted into the seam. Adjacent fasteners in adjacent fastener recesses are offset from the seam. In this regard, the remaining 11 fasteners may attach to the sheathing. Accordingly, it has been determined that nine or more fasteners typically provides adequate pullout strength even when not extending into underlying structural members. Stated otherwise, the number and spacing of the apertures provides adequate pullout strength to meet code requirements even when the base plate **100** is solely attached to sheathing.

[0041] As shown in FIG. 2A, the raised section **110** includes at least first and second transverse channels **116A**, **116B** (hereafter **116** unless specifically referenced) that separate the raised section **110** into multiple independent sections. These channels, if utilized, provide a location for attaching an object to the mounting system and allow for X and Y adjustment of such an object. However, it will be appreciated that not all embodiments of the system **10** require such channels.

[0042] FIGS. 3A and 3B illustrate a top and bottom view of one embodiment of a top cap **120**. As shown, a bottom surface **122** of the top cap **120** is recessed to receive the raised section **110** of the base plate **100**. In the illustrated embodiment, the bottom surface **122** has a plurality of individual recesses that are formed between transverse channels **126A**, **126B** formed in a top surface **124** of the top cap. In the present embodiment, these channels **126A**, **126B** correspond to the channels **116A**, **116B** in the base plate **100**. In this embodiment, each individual recess may receive one of the raised section of the base plate. In any arrangement, the bottom recessed surface is typically continuous around its bottom periphery such that it extends to or near the top surface of the base plate to prevent water from entering under the top cap. In any embodiment, the top surface **124** of the top plate **120** is solid above the fastener recesses in the raised section(s) **110** of the base plate. Thus, the top plate **120** provides weatherproofing for the fastener recesses.

[0043] In the illustrated embodiment, the top cap has a central aperture **130** in its top surface. In this embodiment, the aperture extends into the top cap **120** but does not extend through the cap **120**. Rather the aperture is formed in a ferrule **132** that is supported on the bottom surface of the cap **120**. See FIG. 3B. In one embodiment, where the cap **120** is injection molded, the ferrule may be integrally formed with the cap **120**. In other embodiments, a ferrule or threaded bushing may be inserted in or otherwise affixed to the bottom surface of the cap (e.g., in a corresponding aperture). In any case, the aperture allows for inserting a fastener **180** into the top cap for attaching objects to the top plate. See,

e.g., FIG. 1. Further, while the present embodiment is shown with a single aperture 130 for receiving a fastener, it will be appreciated that multiple apertures may be provided in the top cap.

[0044] As noted, the top surface also includes corresponding channels 126A, 126B (hereafter 126 unless specifically referenced) which are received within the channels 116A, 116B in the base plate, when the top cap 120 is connected to the base plate 110. In the illustrated embodiment, the channels 126 are T-slots. That is, the closed bottom end of each slot is wider than the open upper end. Other shapes are possible. However, it is typically preferred that the slot have an overhanging lip for maintaining object within the slot. Further, in the illustrated embodiment, the slots 126 extend through a side surface 148 of the top cap 120. That is, at least one open end of the slots 126 are exposed on a side surface 148 of the top cap 120 between its top surface 124 and its bottom peripheral edge 123. Use of slots 126 having an exposed end allows for inserting an element with a head/foot that is wider than its body into the slot once the top cap is attached to the base plate. Further, slots with a narrower open end (e.g., overhanging lip) allow maintaining inserted objects within the slot.

[0045] The configuration of the base plate 100 having multiple fastener apertures allows for readily applying multiple base plates to roofing surface in an efficient manner. Specifically, as the base plates do not require placement on a rafter, the base plates may be placed, for example, in a matrix that will support corners of multiple photovoltaic cells. At this time, top caps may be attached to the raised sections 110 of the base plates 100. Importantly the caps overlay the fasteners apertures and provides weatherproofing for the fasteners affixing the base plates to the roof surface. That is, once the cap is attached to the base plate 100 no fasteners are exposed.

[0046] FIGS. 4A-4D illustrate one embodiment of a connection between the top cap 120 and the raised section 110 of the base plate 100. As shown, the top cap 120 includes a spring tab 128 disposed around at least a portion of the inside periphery of its recessed bottom surface 122. The spring tab 128 is received within a corresponding detent 118 formed around at least a portion of the periphery of the raised section 118 of the base plate 110. Accordingly, the top cap 120 is attached to the base plate 100 by placing the top cap 120 over the raised section 110 of the base plate 100 and pushing on the top cap until the spring tab(s) 128 is received within the detent(s) 118. This effectively locks the top cap on to the base plate. Furthermore, it has been found that the top cap is maintained on the base plate with a retraction force that exceeds pullout requirements of most building codes. In this regard, when the top cap 120 is secured to the base plate 100, all of the fasteners are sealed beneath the top cap and the top cap provides a mounting structure for attaching elements to the roof.

[0047] FIG. 5 illustrates a further embodiment of the top cap 120 with a vertical flange 134. In such an arrangement, the vertical flange 134 provides z-axis adjustment for mounting an object to the mounting system. That is, when the flanged top cap 120 is attached to a base plate, slots 136 in the flange 134 may be utilized to attach objects to the mounting system without requiring separate brackets. Further, in the illustrated embodiments, the recessed surface of the top cap 120 and the raised section 110 of the base plate are square. In this regard, the flanged top cap or other top cap

(e.g., having recessed channels) may be attached to the base plate in different orientations. For instance, the flange 134 of the top cap 120 may be disposed in a direction that is up-and-down (y-axis aligned) as illustrated on FIG. 5 or side-to-side (x-axis aligned; not illustrated).

[0048] FIGS. 6A-6D illustrate another embodiment of a mounting system 10 that includes a base plate 100 and top cap 120. Again, the base plate 100 includes a raised section 110, which in the present embodiment includes a plurality of raise sections 110A-I. In this embodiment, four of the raised sections 110B, 110D, 110F, and 110H include threaded apertures 114 for use in attaching the top cap 120 to the base plate 110 and/or fixing an object to the base plate. The remainder of the raise sections 110A, 110C, 110E, 110G, and 110I include fastener recesses 112 for affixing the base plate to a roof surface. As shown in FIG. 6B, the top cap 120 in this embodiment has first and second aperture 130A and 130B. These apertures 130A, 130B may be selectively aligned with an opposing pair of the threaded apertures 114 and the base plate as shown in FIG. 6A. This is illustrated in FIG. 6C which shows the apertures 130A and 130B disposed above the corresponding threaded apertures in the base plate 110. Accordingly, once the top cap 120 is disposed relative to the raised section of the base plate 100, threaded fasteners (e.g., bolts) 142 may extend through the top cap and into the threaded apertures 114 of the base plate 100. See FIG. 6D. At this time, the top cap 120 is securely fastened to the base plate 100. Further, it will be appreciated rather than bolting the top cap 120 directly to the base plate, brackets or other attachment mechanisms may be fitted between the heads of the bolts 142 and top surface of the top cap 120. Further, as with the flanged embodiment disclosed above, the top cap 120 may be rotated 90 degrees to provide connection along different axis. Accordingly, if brackets are utilized, the brackets may be selectively aligned to provide x or y adjustment. Though not illustrated as utilizing a top cap having recess channels, it will be appreciated that the embodiment of FIGS. 6A-6D may utilize a top cap having recess channels.

[0049] FIG. 7A-7C illustrates further embodiment of the mounting system 10. In this embodiment, the base plate 100 supports at least a first stud 150 on one of the raised sections 110. The remaining raised sections may each include a fastener aperture 112. In this embodiment, the top cap 120 has an aperture 130 that matches the location of the stud 150. See FIG. 7B. Accordingly, the top cap may be disposed over the raised section 110 of the base plate 100 and fasten thereto with a threaded element or nut 152. At such time, the top plate is securely affixed to the base plate 100. Though illustrated as utilizing a single stud 150, it will be appreciated that the embodiment of FIGS. 7A-7C may utilize multiple studs. Accordingly, the top cap 120 would likewise have multiple apertures that allow for mating connection between the top cap 120 and base plate 100.

[0050] FIGS. 8A and 8B illustrate a further embodiment of mounting system. As illustrated in FIG. 8A, the base plate 100 again includes a raised section 110 within the periphery of the flange 108. In this embodiment, the raised section forms a continuous enclosed wall that prevents water flowing down the roof surface from entering within the interior of the raised section 110. In the illustrated embodiment, a number of freestanding fastener studs 146 are disposed along the periphery of the continuous wall of the raised section 110 as well as within the interior of the raised section

110. Each of the fastener studs **146** includes a fastener recess **112** that may be utilized to affix the base plate **100** to a roof surface. Further one or more of the fastener studs **146** may be utilized to receive a fastener that fixes a top cap the base plate **110**. As illustrated, this embodiment of a raised section **110** having a continuous sidewall does not permit utilization of the top cap having a recessed channels. Accordingly, a top cap **120** similar to that illustrated in FIG. **8B** may be utilized. As shown, the top cap **120** again has a top surface **124** and bottom recessed surface (not shown) that is sized to receive the continuous sidewall of the raised section **110**. That is, the top cap **120** has a continuous sidewall that is configured to extend around the continuous sidewall of the raised section **110**. In order to affix an object to the top cap **120**, the top cap includes first and second elongated apertures **158A**, **158B** that extend through the top surface **124**. Accordingly, once the top cap **120** is affixed to the base plate **100** (e.g., snap fit mechanical fasteners etc.) T-bolts or other fasteners may be inserted into the elongated apertures to affix an object to the top cap **120**.

[0051] FIGS. **9A-9C** illustrate a further embodiment of the roof mounting system. As shown in FIG. **9A**, the base plate **100** includes a circular raised section **110** disposed within the periphery of the flange **108**. In this embodiment, a number of fastener apertures **112** are disposed within the periphery of the raised section **110**. Further, the raised section **110** is circular and includes threads about its outside periphery. These threads allow for receiving a threaded top cap **120** as illustrated in FIGS. **9B** and **9C**, which show a top and bottom views of a circular top cap **120**. The circular top cap **120** again has a top surface **124** and a recessed bottom surface **122**. The top cap **120** includes a circular sidewall **148** that is threaded about its interior surface. Accordingly, the circular top cap **120** may be threadably engaged with the outside threads on the raised section **110** of the base plate **100**. This embodiment provides not only secure connection between the top cap **120** and the base plate **100** but also provides the additional benefit of height adjustment. That is, the top cap **120** may be threaded to a desired height above the roof surface. In the illustrated embodiment, the top surface **124** of the top cap **120** includes multiple recessed channels **126**. These channels may be utilized to affix an object to the top cap **120**. However, it will be appreciated that other embodiments may omit the recessed channels and use other means (e.g., ferrules) to attach objects to the circular top cap.

[0052] Multiple variations exist for both the base plate and the top plate. FIG. **10** illustrates another embodiment of a top cap **120**. In this embodiment, the top cap includes side clips **162** attached to the side surfaces **148**. These side clips may receive spring tabs (not shown) attached to the base plate.

[0053] FIGS. **11A** and **11B** illustrate a variation of the top cap **120** and a mounting element **170** that is adapted to engage the top cap. As shown, the top cap **120** includes a top surface **124** having a central aperture **130** for receiving a fastener for attaching an object to the cap **120**. Disposed about the central aperture **130** are four recesses **168** that extend into but not through the top surface of the top cap. These recesses are configured to receive tabs **172** formed on the bottom surface of the mounting element **170**. As shown, the mounting element is a vertical flange **176** having an elongated aperture **178** that may be affixed to the aperture **130** of the top cap **120** and/or the base plate (not shown) via an aperture **174** extending through a base of the mounting element **170**. By aligning the two tabs **172** with two of the

four recesses **168** in the top surface of the top cap, the x or y orientation of the mounting element **170** may be fixed.

[0054] FIG. **12** illustrates another embodiment of an attachment element **170** that may be attached to the top cap and/or base plate. As shown, the attachment element has a generally circular base **186**, which may have a recess **188** for receiving a pliable washer. A threaded stud **190** extends from the circular base **186**. This stud may be threaded into the top cap or base plate. An upper end of the attachment element includes a flange **176** with an elongated aperture **178**.

[0055] FIGS. **13** and **14** illustrate two non-limiting examples of attachment elements **190** that may be inserted into recessed channels of the top plates. FIG. **13** illustrates and attachment element **190** having first and second T-shaped feet **192a**, **192b** that may be inserted into corresponding recesses in a top plate. Though shown as being T-shaped, it will be appreciated that the feet **192** may have any shape that corresponds to the shape of the recess. In the present embodiment, a body **194** having an elongated aperture **196** extend between the feet **192**. The body is offset from the feet to allow it to extend above the top surface of a top plate when inserted into the channels of the top plate. The elongated aperture **196** may be used to attach and object to the attachment element and/or affix the position of the attachment element to the top plate. For instance, a bolt may be threaded through the aperture (e.g., a nut may be supported below the aperture to engage the top surface of the top plate. Such a bolt may affix the attachment element at a desired location in the recessed channel(s). FIG. **14** illustrates an attachment element **190** having a single foot **192** and a U-shaped body. The U-shaped body **194** may be of considerable length to allow the body to extend between two or more aligned mounting systems. The U-shaped body may provide a location to house cabling when used with PV panels. Further, the open end of the U-shaped body may include a cover **198** that protects elements (e.g., cabling) disposed in the U-shaped body.

[0056] As noted above, the embodiments of FIGS. **6A-7C** disclose the use of studs and or nuts as incorporated into the base plate **110**. FIG. **15** illustrates a T-bolt stud **150** and a T-nut **114** that may be affixed to the base plate. Both the stud **150** and nut **114** include an elongated foot that may be disposed within one or more recesses **104** in the bottom surface of the base plate **110**. See, e.g., FIG. **2B**.

[0057] In any embodiment, it will be appreciated that certain variations may be made in are considered within the scope of the presented inventions. For instance, the height (e.g. thickness) of the top plate may be adjusted to provide differing finished heights for the mounting system. Alternatively, various different objects may be attached to the top cap and/or base plate to provide differing mounting points. Various such objects are described in co-owned US patent publication number 20130291479, which is incorporated herein by reference. The **479** publication shows further numerous embodiments of objects that may be attached to the presented mounting systems.

[0058] In various embodiments, these mounting structures may provide X and or Y adjustment and/or hinged adjustment. In a further arrangement, one or more of the channels in the top cap faceplate may be utilized to affix an inverter to a roof surface. Likewise, various cable mounting channels may be provided for attachment to the top plate. Such an arrangement, such channels may extend between multiple plates.

[0059] Although the system has been discussed in terms of mounting solar panels on roofs, it is to be understood that the various assemblies could be used to mount any number of devices on roofs or other surfaces with little or no modification. Devices that could be mounted, include, but are not limited to photovoltaic (framed and unframed), thermal, hybrid collectors, antennas, telecom equipment, pipes, conduits, and others. For unframed solar panels known in the art, rubber pads would be used to protect the panel.

[0060] In all embodiments, the components can be made of aluminum, copper, mild steel, stainless steel, nickel, or other metals, coated metal, plastic, fiberglass, composites, ceramic, carbon fiber material, rubber polymer, concrete, cementitious or any other material with the necessary physical characteristic. In some applications the assembly will need to be conducting, in order to allow for grounding of the components mounted on the system. In all embodiments, if desired the installer can put caulk or other sealant around all joints as a further assurance of water proof joints. This is not necessary under normal usage conditions, but may be desired in harsh environments and/or remote locations.

[0061] While a number of exemplary aspects and embodiments have been discussed above, those of skill in the art will recognize certain modifications, permutations, additions and subcombinations therefore. It is therefore intended that the following appended claims hereinafter introduced are interpreted to include all such modifications, permutations, additions and subcombinations are within their true spirit and scope. Each apparatus embodiment described herein has numerous equivalents.

[0062] The terms and expressions which have been employed are used as terms of description and not of limitation, and there is no intention in the use of such terms and expressions of excluding any equivalents of the features shown and described or portions thereof, but it is recognized that various modifications are possible within the scope of the invention claimed. Thus, it should be understood that although the present invention has been specifically disclosed by preferred embodiments and optional features,

modification and variation of the concepts herein disclosed may be resorted to by those skilled in the art, and that such modifications and variations are considered to be within the scope of this invention as defined by the appended claims. Whenever a range is given in the specification, all intermediate ranges and subranges, as well as all individual values included in the ranges given are intended to be included in the disclosure. When a Markush group or other grouping is used herein, all individual members of the group and all combinations and subcombinations possible of the group are intended to be individually included in the disclosure.

[0063] In general the terms and phrases used herein have their art-recognized meaning, which can be found by reference to standard texts, journal references and contexts known to those skilled in the art. The above definitions are provided to clarify their specific use in the context of the invention.

1. A roof mounting device, comprising:

a base plate having:

an elevated section on a top surface of said base plate and disposed within a periphery of said top surface of said base plate, wherein the base plate forms a flange around said elevated section;

a plurality of fastener recesses disposed within a periphery of said elevated section, wherein said fastener recesses extend through at least a portion of said base plate;

a top cap having:

a top surface;

an at least partially recessed bottom surface, wherein said recessed bottom surface is sized to receive said elevated section of said base plate when said top cap is disposed on said base plate;

a fastener for attaching said top cap to said base plate; and

at least one attachment structure for attaching a component to said top cap.

* * * * *