



US011860588B1

(12) **United States Patent**  
**Spencer et al.**

(10) **Patent No.:** **US 11,860,588 B1**

(45) **Date of Patent:** **Jan. 2, 2024**

(54) **IDENTIFICATION OF WATCH BANDS**

(71) Applicant: **Apple Inc.**, Cupertino, CA (US)

(72) Inventors: **Maegan K. Spencer**, Emerald Hills, CA (US); **Ryan C. Perkins**, San Francisco, CA (US); **Benjamin J. Kallman**, Cupertino, CA (US); **Daniel J. Hiemstra**, San Jose, CA (US); **Colin M. Ely**, Sunnyvale, CA (US); **William C. Lukens**, San Francisco, CA (US); **Osamu Yabe**, Mountain View, CA (US); **Jorge L. Rivera Espinoza**, San Jose, CA (US); **David D. Dashevsky**, Cupertino, CA (US); **Eugene C. Cheung**, Redwood City, CA (US); **Prashanth S. Holenarsipur**, Fremont, CA (US); **Tyler S. Bushnell**, Mountain View, CA (US); **Zaki Moustafa**, Palo Alto, CA (US)

(73) Assignee: **Apple Inc.**, Cupertino, CA (US)

(\*) Notice: Subject to any disclaimer, the term of this patent is extended or adjusted under 35 U.S.C. 154(b) by 511 days.

(21) Appl. No.: **17/200,650**

(22) Filed: **Mar. 12, 2021**

**Related U.S. Application Data**

(60) Provisional application No. 62/992,076, filed on Mar. 19, 2020, provisional application No. 62/989,527, filed on Mar. 13, 2020.

(51) **Int. Cl.**  
**G04G 9/00** (2006.01)  
**G04G 21/02** (2010.01)  
(Continued)

(52) **U.S. Cl.**

CPC ..... **G04G 9/0064** (2013.01); **A44C 5/0053** (2013.01); **A44C 5/147** (2013.01);  
(Continued)

(58) **Field of Classification Search**

CPC ..... G04G 9/0064; G04G 21/02; G04G 21/04; A44C 5/0053; A44C 5/147;  
(Continued)

(56) **References Cited**

**U.S. PATENT DOCUMENTS**

8,725,842 B1 5/2014 Al-Nasser  
10,691,072 B1 6/2020 Johnson  
(Continued)

**FOREIGN PATENT DOCUMENTS**

WO WO 2015/047363 4/2015

*Primary Examiner* — Edwin A. Leon

(74) *Attorney, Agent, or Firm* — BAKERHOSTETLER

(57) **ABSTRACT**

A watch can include a watch body and a band for securing the watch to the user. The watch body can detect an identification of the band or combination of band portions, which can serve as an input to initiate actions performed by the watch body. For example, a type, model, color, size, or other characteristic of a band can be determined and used to select a corresponding action performed by the watch body. Identification of the band can be performed by components of the watch body that also serve other purposes. The watch body can respond to the identification of a particular band by performing particular functions, such as changing an aspect of a user interface or altering settings of the watch body.

**20 Claims, 7 Drawing Sheets**

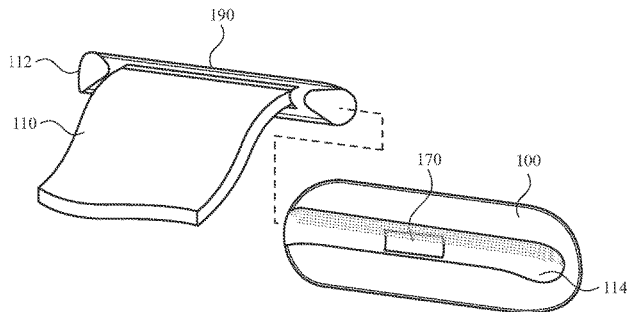
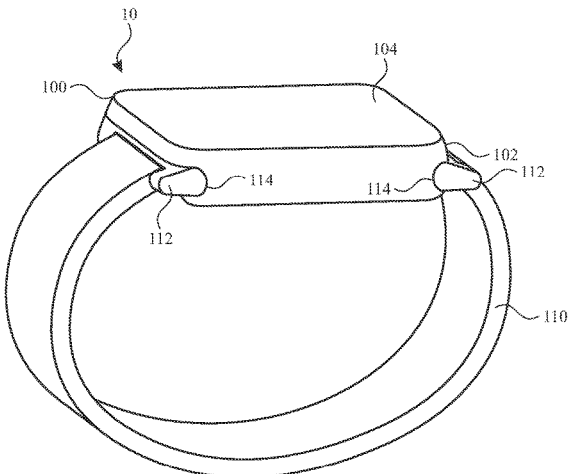

- (51) **Int. Cl.**  
*G04G 21/04* (2013.01)  
*A44C 5/00* (2006.01)  
*A44C 5/14* (2006.01)  
*G06K 7/14* (2006.01)  
*G06K 19/06* (2006.01)  
*G06K 19/07* (2006.01)  
*G06K 7/10* (2006.01)

- (52) **U.S. Cl.**  
 CPC ..... *G04G 21/02* (2013.01); *G04G 21/04*  
 (2013.01); *G06K 7/10366* (2013.01); *G06K*  
*7/1413* (2013.01); *G06K 7/1417* (2013.01);  
*G06K 19/06028* (2013.01); *G06K 19/06037*  
 (2013.01); *G06K 19/0723* (2013.01)

- (58) **Field of Classification Search**  
 CPC ..... G06K 7/10366; G06K 7/1413; G06K  
 7/1417; G06K 19/06028; G06K  
 19/06037; G06K 19/0723  
 See application file for complete search history.

(56) **References Cited**

U.S. PATENT DOCUMENTS

11,287,779	B2 *	3/2022	Spencer	.....	G04G 17/06
2014/0239065	A1 *	8/2014	Zhou	.....	G06F 1/1677
					235/380
2014/0337621	A1 *	11/2014	Nakhimov	.....	H04W 12/068
					713/168
2016/0262028	A1	9/2016	Reddy et al.		
2018/0227754	A1 *	8/2018	Paez Velazquez	.....	H04L 63/0428
2022/0100151	A1 *	3/2022	Pandya	.....	G04G 17/08

\* cited by examiner

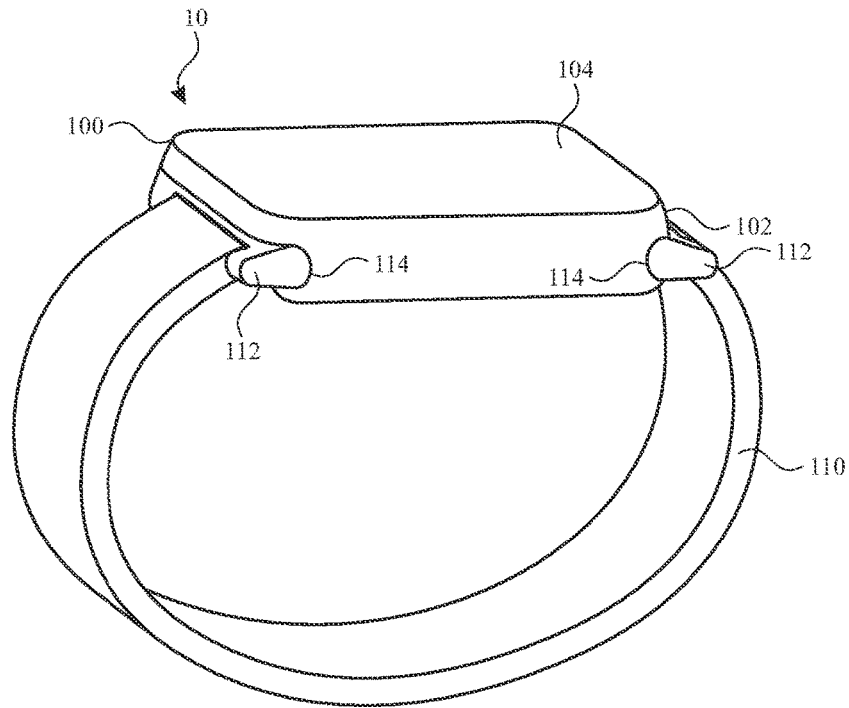

FIG. 1

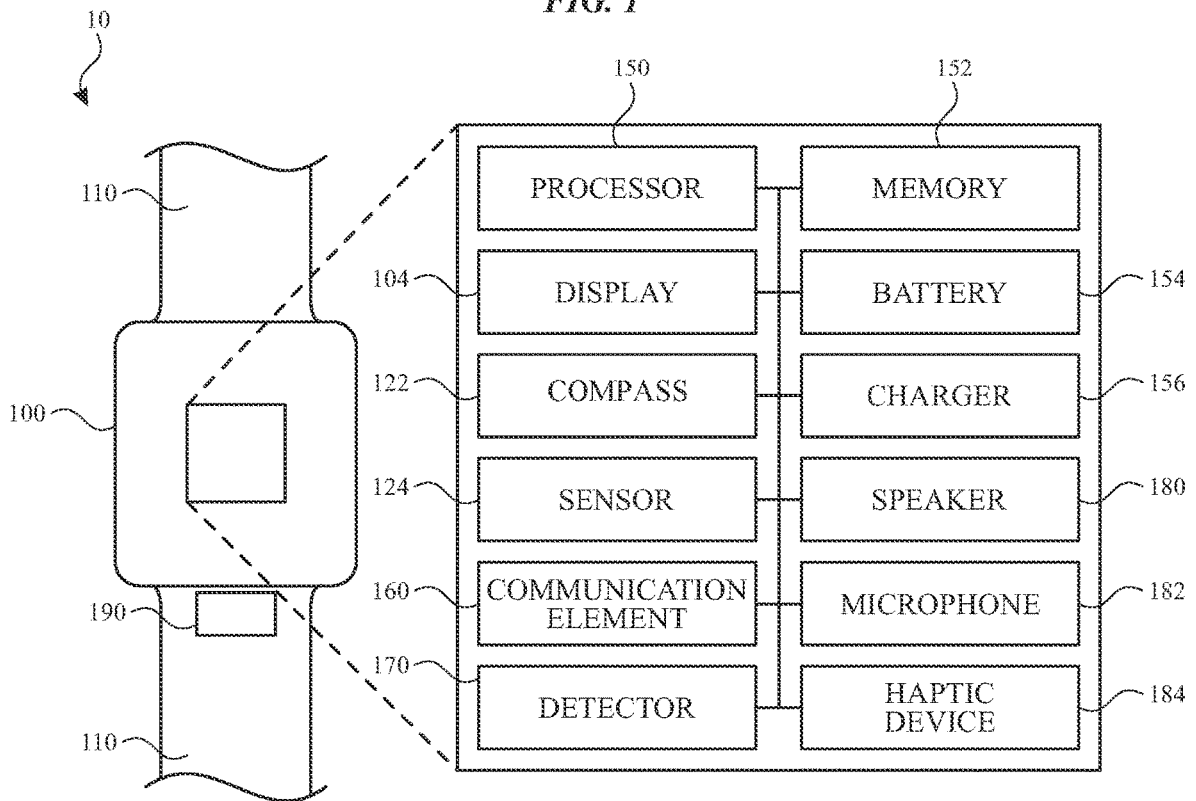

FIG. 2

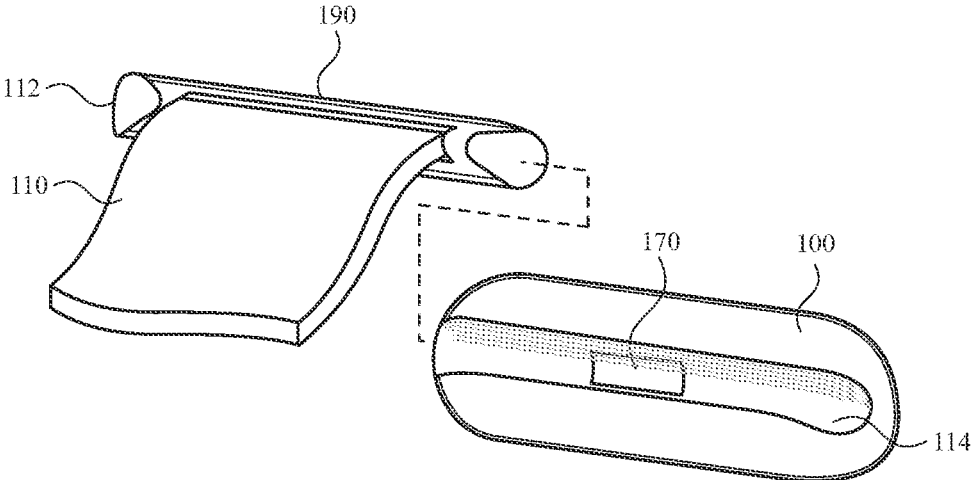

FIG. 3

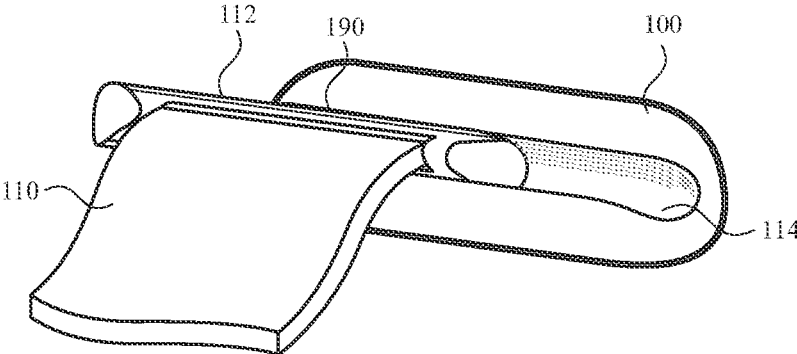

FIG. 4

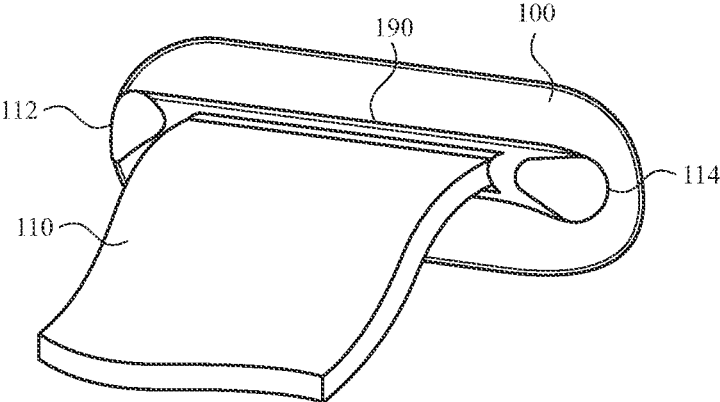

FIG. 5

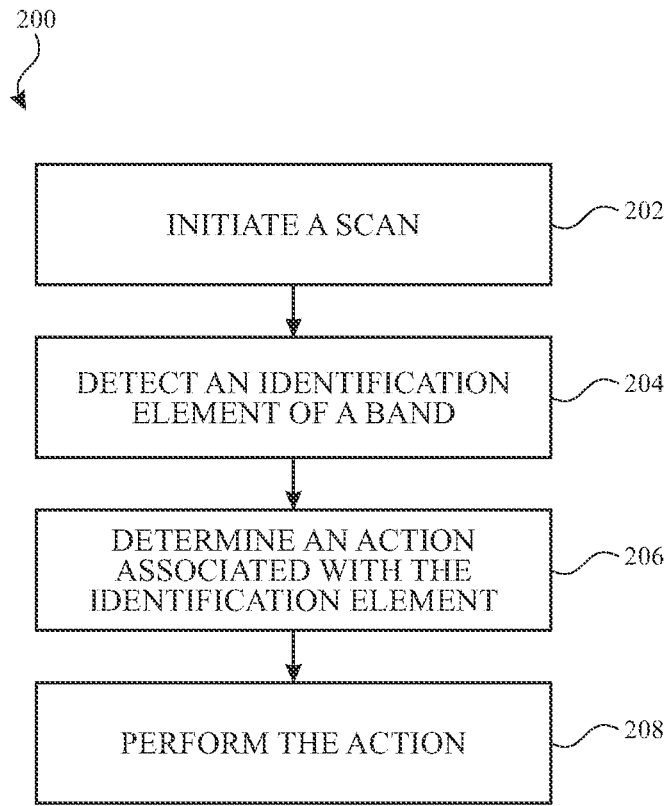

FIG. 6

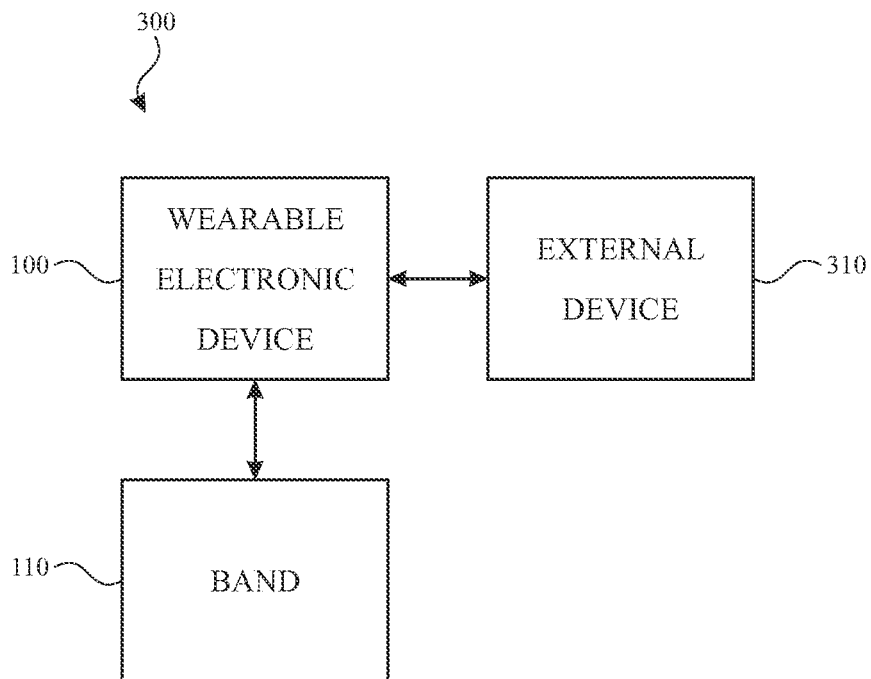

FIG. 7

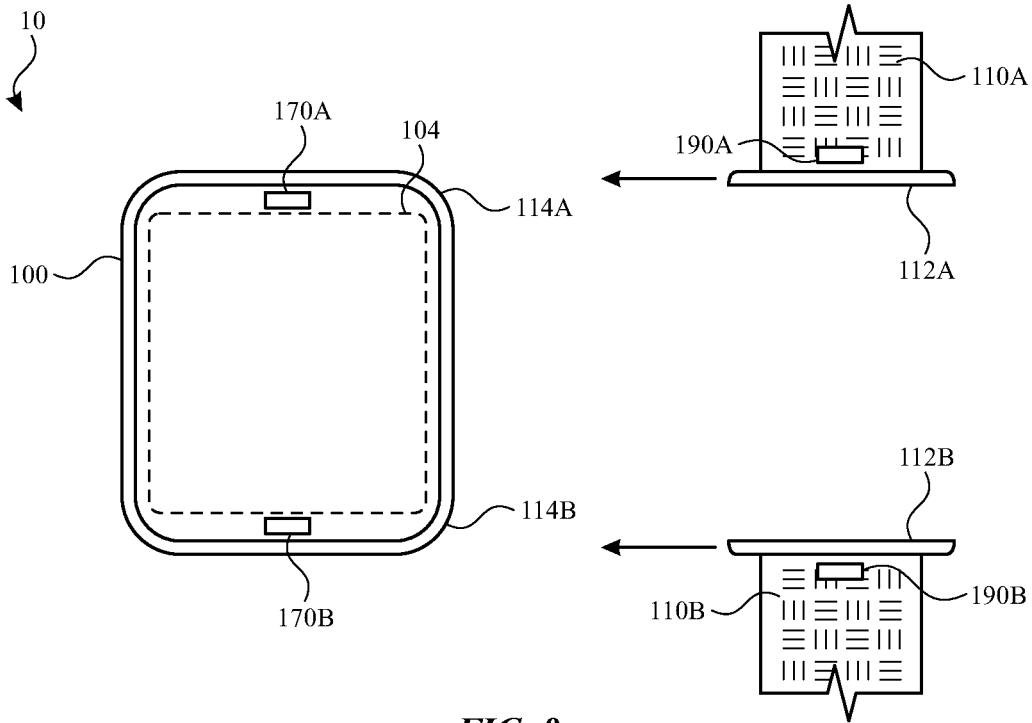

FIG. 8

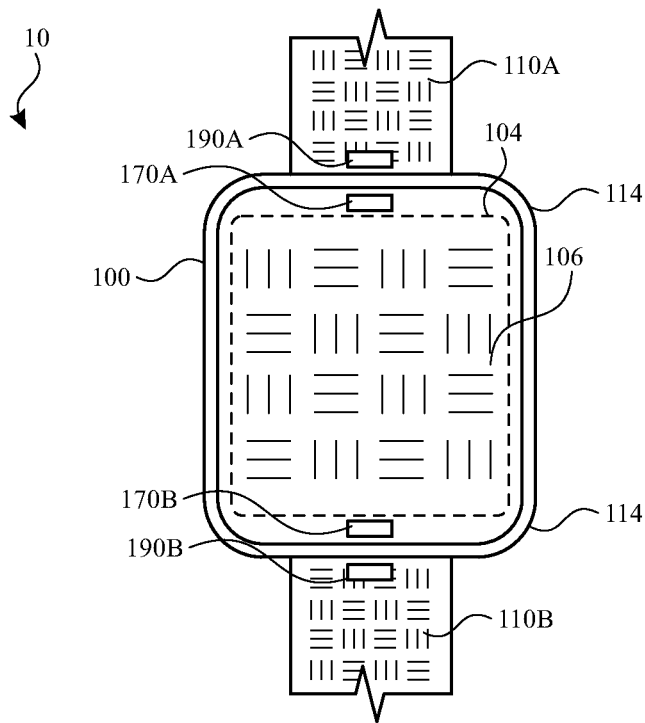

FIG. 9

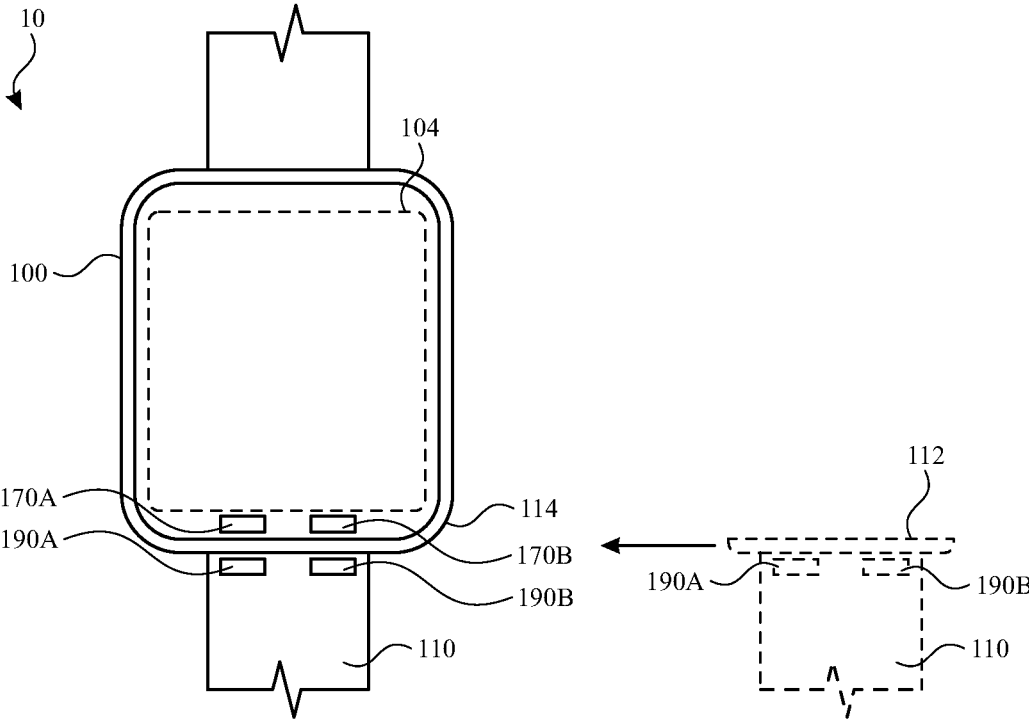

FIG. 10

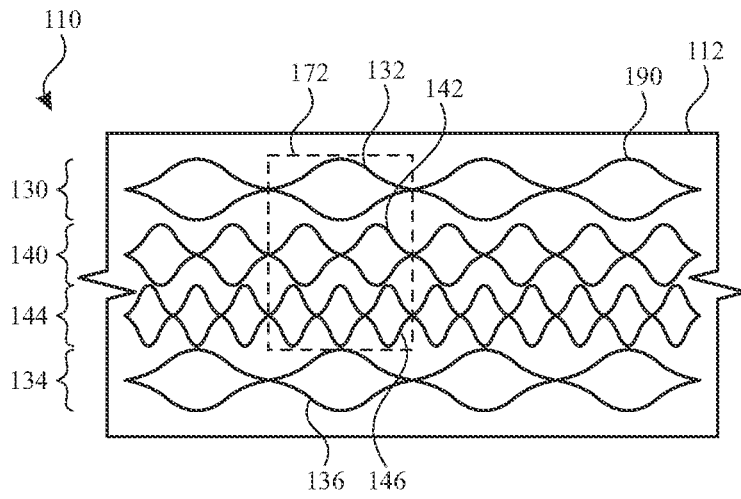

FIG. 11

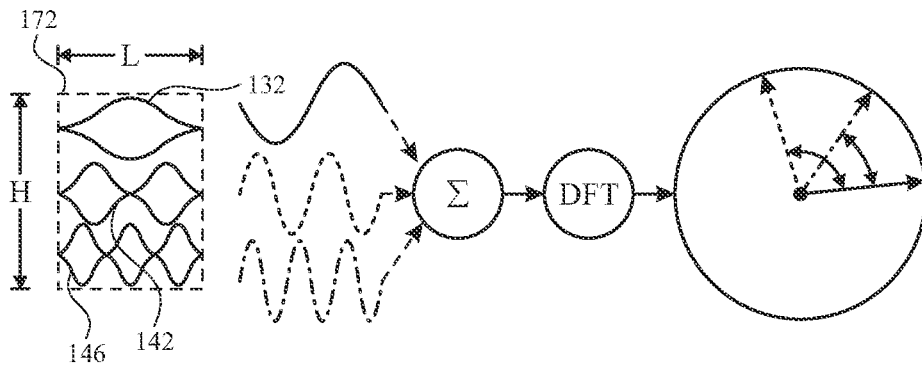

FIG. 12

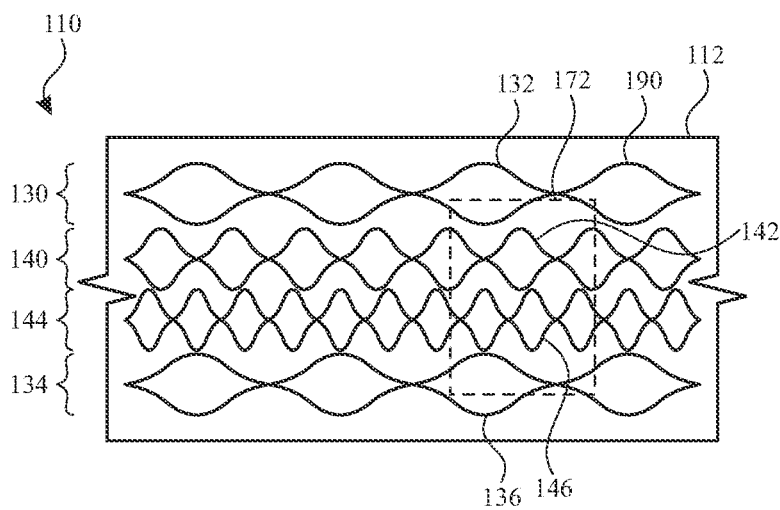

FIG. 13



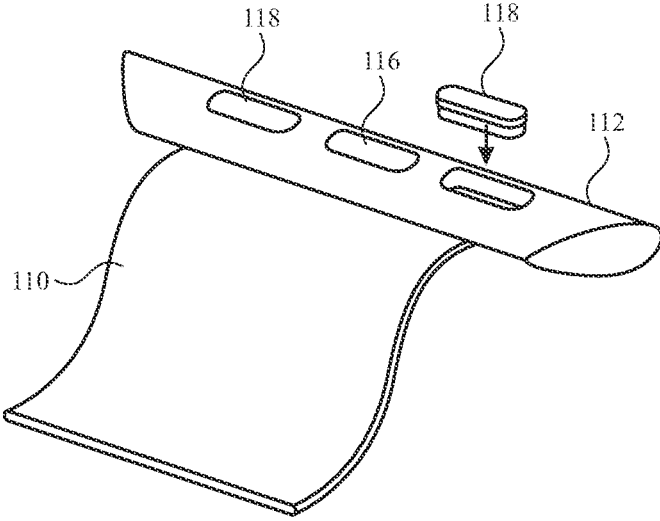

FIG. 14

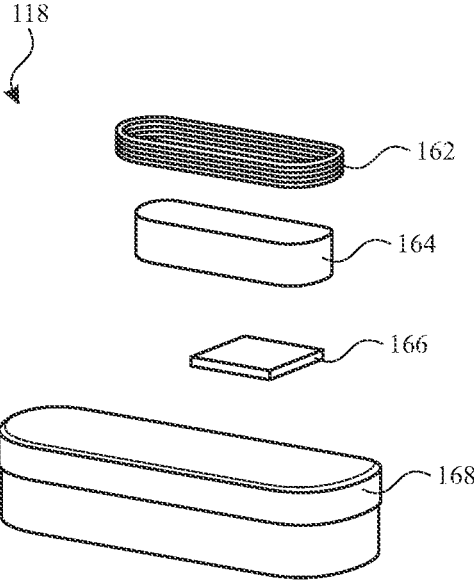

FIG. 15

**IDENTIFICATION OF WATCH BANDS****CROSS-REFERENCE TO RELATED APPLICATION**

This application claims the benefit of U.S. Provisional Application No. 62/989,527, entitled "IDENTIFICATION OF WATCH BANDS," filed Mar. 13, 2020 and U.S. Provisional Patent Application No. 62/992,076, entitled "BAND IDENTIFIER SYSTEM FOR WEARABLE DEVICES," filed on Mar. 19, 2020, the entirety of each of which is incorporated herein by reference.

**FIELD**

The described embodiments relate generally to wearable electronic devices. More particularly, the present embodiments relate to identification of bands for watches and corresponding actions based on the identification.

**BACKGROUND**

Portable electronic devices, including watches, have become increasingly popular, and the features and functionality provided by portable electronic devices continue to expand to meet the needs and expectations of many consumers. With some wearable electronic devices, the component parts are modular and exchangeable. For example, electronic wristwatches can allow a user to select one of a variety of bands for securing the electronic components to the user. The user can select and exchange bands based on a preference for certain characteristics of a given band.

However, some traditional portable electronic devices, particularly wearable electronic devices, may have relatively limited functionality or are only able to perform a specialized set of functions or tasks. Some portable electronic devices operate without regard to the band selected for use therewith. The embodiments described herein are directed to a wearable device that provides a wide range of functionality that can be influenced by selection of a band.

**BRIEF DESCRIPTION OF THE DRAWINGS**

The disclosure will be readily understood by the following detailed description in conjunction with the accompanying drawings, wherein like reference numerals designate like structural elements, and in which:

FIG. 1 illustrates a perspective view of a watch.

FIG. 2 illustrates a simplified system diagram of a watch.

FIG. 3 illustrates a perspective view of a watch prior to insertion of a band into a watch body.

FIG. 4 illustrates a perspective view of the watch of FIG. 3, during insertion of the band into the watch body.

FIG. 5 illustrates a perspective view of the watch of FIG. 3, after insertion of the band into the watch body.

FIG. 6 illustrates a flow chart of a process for detecting a band.

FIG. 7 illustrates a block diagram of a system.

FIG. 8 illustrates a front view of a portion of a watch having first and second band portions.

FIG. 9 illustrates a front view of the watch of FIG. 8 having first and second band portions.

FIG. 10 illustrates a front view of a portion of a watch with a band for insertion into a watch body.

FIG. 11 illustrates a front view of a portion of a band having an identification element with multiple rows of repeating patterns.

FIG. 12 illustrates a chart of a process for optically detecting a band.

FIG. 13 illustrates a front view of the portion of the band of FIG. 11 with a view in a different location thereon.

FIG. 14 illustrates a perspective view of a portion of a band having an identification element within a bumper.

FIG. 15 illustrates an exploded view of the bumper of FIG. 14.

In one or more implementations, not all of the depicted components in each figure may be required, and one or more implementations may include additional components not shown in a figure. Variations in the arrangement and type of the components may be made without departing from the scope of the subject disclosure. Additional components, different components, or fewer components may be utilized within the scope of the subject disclosure.

**DETAILED DESCRIPTION**

The detailed description set forth below is intended as a description of various implementations and is not intended to represent the only implementations in which the subject technology may be practiced. As those skilled in the art would realize, the described implementations may be modified in various different ways, all without departing from the scope of the present disclosure. Accordingly, the drawings and description are to be regarded as illustrative in nature and not restrictive.

The following disclosure relates to identification of a band for use with an electronic device. The identification can serve as an input to initiate actions performed by the electronic device. For example, a type, model, color, size, or other characteristic of a band can be determined and used to select a corresponding action performed by the electronic device.

A watch can include a watch body and a band for securing the electronic device to the user. In many traditional devices, the electronic device does not interact with or even identify the band that is used in conjunction with the electronic device. In other devices, the band may provide certain functionality to supplement the functionality of the electronic device. However, such bands often require a power source, such as from an integrated battery or from the battery of the electronic device. Furthermore, such bands often require a robust communication link with the electronic device for bidirectional communication. These features impose significant design considerations that increase the cost and complexity of the parts.

In contrast to traditional devices, the band identification capabilities described herein provide simple and elegant solutions that allow an electronic device to readily identify a band. In some embodiments of the present disclosure, identification of the band can be achieved by a variety of mechanisms. For example, identification of the band can be performed by components of the electronic device that also serve other purposes. Existing sensors, communication elements, and/or detectors can be used to detect and identify a band provided to the electronic device. Accordingly, identification of a band with the electronic device can be achieved without adding dedicated components to the electronic device. Furthermore, identification can be achieved without sacrificing power to the band and without requiring a bidirectional communication link with the band.

A selection of a certain band can influence operation of the electronic device in a variety of ways. For example, the electronic device can respond to the identification of a particular band by performing particular functions, such as

changing an aspect of a user interface or altering settings of the electronic device. Such functions can be readily executed by the electronic device upon identification of the band, such that user input is not required. Accordingly, a user's experience with the electronic device can be enhanced based on the user's selection of a particular band.

These and other embodiments are discussed below with reference to FIGS. 1-15. However, those skilled in the art will readily appreciate that the detailed description given herein with respect to these figures is for explanatory purposes only and should not be construed as limiting.

FIG. 1 illustrates a perspective view of a watch 10. The watch 10 can include a watch body 100 and a band 110. As shown, the watch body 100 includes a housing 102 that supports a display 104. The watch body 100 can be worn on a user's wrist and secured thereto by the band 110. The band 110 includes lugs 112 at opposing ends of the band that fit within respective recesses or channels 114 of the housing 102 and allow the band 110 to be removably attached to the housing 102. The lugs 112 may be part of the band 110 or may be separable (and/or separate) from the band 110. Generally, the lugs 112 may lock into the channels 114 and thereby maintain connection between the band 110 and the housing 102. The user may release a locking mechanism (not shown) to permit the lugs 112 to slide or otherwise move out of the channels 114. In some watches, the channels 114 may be formed in the band 110 and the lugs may be affixed or incorporated into the housing 102. While lugs 112 and channels 114 are illustrated, it will be recognized that other attachment elements, such as locks, snaps, clasps, threads, and pins can be included on the band 110 for securely attaching to the watch body 100.

As shown in FIG. 2, the band 110 can include an identification element 190 that is detectable by one or more components of the watch body 100. Features of the identification element 190 can be selected to achieve detection by the watch body 100, as described further herein. For example, the identification element 190 can include a feature on a surface of the band 110 and/or be embedded within the structure of the band 110. The identification element 190 can be positioned on or along any portion of the band 110 to facilitate detection. For example, the identification element 190 can be located near an end of the band 110 (e.g., at or near a lug 112). Alternatively or in combination, the identification element 190 can be located on a side of the watch 10 that is opposite the watch body 100. The identification element 190 can be used to determine information about the band 110, such as a type, characteristic, feature, or identity of the band 110. Subsequent actions by the watch body 100 can correspond to the determined information.

As further shown in FIG. 2, the watch body 100 can include components that support the operations thereof. Such operations can include identification of a band 110, actions based on the identification, and other operations that are independent of the identification. In some embodiments, components used for operations independent of the identification of the band 110 can also be used for identification. Such components are described below with reference to FIG. 2.

In some embodiments, as shown in FIG. 2, the watch body 100 includes a processor 150, memory 152, a power source 154, and/or a charger 156 for providing power to the power source 154.

The processor 150 can control or coordinate some or all of the operations of the watch body 100. The processor 150 can communicate, either directly or indirectly with substantially all of the components of the watch body 100. For

example, a system bus or signal line or other communication mechanisms can provide communication between the processor 150, the memory 152, the power source 154, as well as other components. The processor 150 can be implemented as any electronic device capable of processing, receiving, or transmitting data or instructions. As described herein, the term "processor" is meant to encompass a single processor or processing unit, multiple processors, multiple processing units, or other suitably configured computing element or elements.

The memory 152 can store electronic data that can be used by the watch body 100. For example, a memory can store electrical data or content such as, for example, audio and video files, documents and applications, device settings and user preferences, timing and control signals or data for the haptic device 184, data structures or databases, and so on. The memory 152 can be configured as any type of memory. By way of example only, the memory can be implemented as random access memory, read-only memory, Flash memory, removable memory, or other types of storage elements, or combinations of such devices.

A power source 154 can be implemented with any device capable of providing energy to the watch body 100. For example, the power source 154 can be a battery and/or a connection cable that connects the charger 156 to another power source such as a wall outlet. In other examples, wireless power can be used.

In some embodiments, as shown in FIG. 2, the watch body 100 can include components for interacting with a user. In some embodiments, the watch body 100 includes a display 104, a speaker 180, a microphone 182, and/or a haptic device 184.

The display 104 may provide an image or video output for the watch body 100. The display 104 may also provide an input surface for one or more input devices such as a touch sensing device, force sensing device, temperature sensing device, and/or a fingerprint sensor. The display 104 may be any size suitable for inclusion at least partially within the housing 102 of the watch body 100 and may be positioned substantially anywhere on the watch body 100. Other input devices can be provided for operation by a user. For example, one or more buttons, dials, crowns, switches, or other devices can be provided for receiving input from a user.

The haptic device 184 can be implemented as any suitable device configured to provide force feedback, vibratory feedback, tactile sensations, and the like. For example, in one embodiment, the haptic device 184 may be implemented as a linear actuator configured to provide a punctuated haptic feedback, such as a tap or a knock.

In some embodiments, as shown in FIG. 2, the watch body 100 can include components that facilitate detection of an identification element 190, among other functions. In some embodiments, the watch body 100 includes a sensor 124 (e.g., biometric sensors, environmental sensors, etc.), a communication element 160, and/or a detector 170. As used herein, "a sensor" can include or be operably connected to any component that is capable of facilitating detection of an identification element 190. A sensor can include or be operably connected to the sensor 124, the communication element 160, and/or the detector 170. As described herein, components of the watch body 100 can be used as sensors for detection of an identification element 190, yet also have other functions apart from detection of the identification element 190.

The watch body 100 can include a compass 122. The compass 122 can include a magnetometer for detecting a

presence and direction of a magnetic field. The compass 122 can be configured to detect a magnetic field of the Earth, and thereby provide information that can be used to determine the orientation of the watch body 100 with respect to magnetic poles of the Earth. The compass 122 can also be operated to detect magnetic fields from other sources, such as the identification element 190 of the band 110, as discussed further herein.

The watch body 100 may also include one or more sensors 124 positioned substantially anywhere on the watch body 100. The sensor or sensors 124 may be configured to sense substantially any type of characteristic such as, but not limited to, images, pressure, light, touch, force, temperature, position, motion, and so on. For example, the sensor(s) 124 may be a photodetector, a temperature sensor, a light or optical sensor, an atmospheric pressure sensor, a humidity sensor, a magnet, a gyroscope, an accelerometer, and so on. In other examples, the watch body 100 may include one or more health sensors. In some examples, the health sensors can be disposed on a bottom surface of the housing of the watch body 100, as discussed further herein. Other sensors 124 or detectors 170 can be provided with similar or different functionality.

The communication element 160 can facilitate transmission of data to or from other electronic devices across standardized or proprietary protocols. For example, a communication element 160 can transmit electronic signals via a wireless and/or wired network connection. Examples of wireless and wired network connections include, but are not limited to, cellular, Wi-Fi, Bluetooth, infrared, RFID and Ethernet. The communication element 160 can communicate with or sense the band 110 or another device, as described further herein.

Referring now to FIGS. 3-5, the watch body 100 can detect an identification element 190 of a band 110 by operating one or more detectors 170. As shown in FIGS. 3-5, a lug 112 can include an identification element 190. The detector 170 of the watch body 100 can be located at or near the channel 114 into which the lug 112 is received. As shown in FIGS. 4 and 5, as the lug 112 is inserted into the channel 114, the identification element 190 is brought into alignment with and close proximity to the detector 170. While the identification element 190 is shown in FIGS. 3-5 as being at the lug 112, it will be recognized that the identification element 190 can be located at other positions. For example, the identification element 190 can be at any location at, on, or within the band 110, including any distance away from the lug 112.

In some embodiments, a detector 170 can be used to detect the identification element 190 before, during, and/or after the band 110 is attached to the watch body 100. For example, the detector 170 can be operated to detect identification element 190 of the band 110 while the band is not connected to the watch body (e.g., with the lug 112 not inserted into the channel 114), as shown in FIG. 3. By further example, the detector 170 can be operated to detect identification element 190 of the band 110 while the band is being connected to the watch body (e.g., while the lug 112 is moving into the channel 114), as shown in FIG. 4. By further example, the detector 170 can be operated to detect identification element 190 of the band 110 after the band is connected to the watch body (e.g., with the lug 112 inserted into the channel 114), as shown in FIG. 5.

In some embodiments, the detector 170 can include one or more contact pins within the channel 114 for providing an electrically conductive pathway to the identification element 190. Multiple pins can be provided to conduct power,

provide a connection to ground, and transmit signals. The pins of the detector 170 can retract within the channel 114 to accommodate passage of the lug 112.

In some embodiments, the detector 170 can optically sense the identification element 190 on the lug 112 or another portion of the band 110. A light source can be provided to facilitate optical sensing by the detector 170. For example, the detector can include or be accompanied by a light source that illuminates the identification element 190, and the detector can optically detect the light reflected off of the identification element 190, as discussed further herein.

For example, the band 110 can be positioned so that the identification element 190 is within a light path of a light source and within a field of view of the detector 170. Light emitted from the light source can be reflected off of the identification element 190. For example, the identification element 190 can include a pattern on the band 110 that reflects the wavelength(s) of light emitted from the light source. The light can be infrared light, visible light, or another wavelength value or range. Where the identification element 190 reflects light outside of the visible spectrum, it can be non-visible to a user. For example, the identification element 190 can include ultraviolet-reflective ink. As such, the identification element 190 can provide identification capabilities without being noticeable by a user.

In some embodiments, the detector 170 can directly detect an intrinsic characteristic of a band 110. For example, various bands 110 can be of different materials, constructions, textures, and/or colors. The detector 170 can distinguish one or more characteristics of a given band 110 from those of another band 110. The detector 170 can optically detect certain characteristics, such as color and reflectivity, of a band 110 and identify the band 110 based on whether it satisfies expected criteria relating to the detected characteristics. For example, the detector 170 can distinguish the color and reflectivity of a stainless steel band from the color and reflectivity of a brown leather band. Thereby, the watch body 100 can identify each of the bands 110 and perform corresponding actions.

In some embodiments, the detector 170 include a magnetic field sensor (e.g., compass, magnetometer, Hall Effect sensor, etc.) and the identification element 190 can include one or more magnets. For example, the detector 170 can detect the magnitude, orientation, or other characteristic of a magnetic field emitted by the identification element 190. The detected characteristic can have a distinct signature that is unique to the identification element 190. Thereby, the watch body 100 can identify the band 110 and perform corresponding actions.

By further example, where multiple magnets are included, the identification element 190 can include an arrangement of the magnets (e.g., different north-south orientations) that is distinct from the arrangement of another identification element 190 of a different band 110. The magnets can be arranged across the lug 112, such that insertion of the lug 112 into the channel 114 allows each of the magnets to pass across the detector 170. Such action can automatically activate sensing by the detector 170. The detector 170 can detect each of the magnets and determine an arrangement (e.g., north-south) thereof based on the magnetic fields of each magnet. The combined arrangement can have a distinct signature that is unique to the identification element 190. Thereby, the watch body 100 can identify the band 110 and perform corresponding actions.

In some embodiments, the detector 170 of the watch can include or operate in concert with a compass of the watch. For example, the same compass that is operated to detect a

magnetic field of the Earth can be operated to detect the identification element **190**. The presence of a magnetic field from the identification element **190** can be detected by the same compass that is then calibrated to detect the magnetic field of the Earth. Likewise, the removal and/or absence of the magnetic field from the identification element **190** can be detected by the same compass that is then calibrated to detect the magnetic field of the Earth

In some embodiments, the watch body **100** can detect an identification element **190** of a band **110** by using a detector that applies a communication protocol. Wireless or wired communication can be performed, at least in part, by a detector **170** that includes or operates in concert with a communication element (e.g., communication element **160**) of the watch body **100**. Communication between the band **110** and the watch body **100** can employ a short-range communication method, such as near field communication (“NFC”), radio-frequency identification (“RFID”), Bluetooth, Wi-Fi, Wi-Fi Direct, short-range 802.11, and high frequency focused beams such as 60 GHz. Alternatively or additionally, communication between the band **110** and the watch body **100** can employ a high frequency communication method, such as WirelessHD, WiGig, and Wi-Fi IEEE 802.11ad. Alternatively or additionally, communication between the band **110** and the watch body **100** can be with ultra-wideband (“UWB”), using low energy levels for short-range, high-bandwidth communications over a large portion of the radio spectrum (e.g., >500 MHz).

For example, the watch body **100** can be placed near the band **110**. The watch body **100** and the band **110** can include a wireless system that is configured to enable one-way or two-way communications. The one- or two-way communication may include an identification of the band **110** and the watch body **100** to initiate a data connection between the two devices. The user initiates a communication between the watch body **100** and the band **110** by placing the watch body **100** near the identification element **190** (e.g., a tag). In some embodiments, the watch body **100** is configured to automatically detect the presence of the identification element **190** and initiate an identification process or routine. The system may include a unique identifier or signature that may be used to authenticate the identity of the band **110**.

In some embodiments, the detector **170** include an antenna and the identification element **190** can include one or more features that reflect radiation. For example, the detector **170** can emit electromagnetic radiation (e.g., RF, WiFi, UWB, EHF, mmWave, etc.). The housing or other component of the watch body **100** can provide transmission of such radiation between the detector **170** and the identification element **190**. For example, the housing can provide a window that transmits radiation to and/or from the channel **114** and the lug **112**. The identification element **190** can include a surface, coating, or other feature that reflects the radiation. Such reflection can be passive or actively managed. The identification element **190** can be tuned to a resonant frequency, such that the reflection occurs at a particular frequency that is detectable by the detector **170**. The reflection of the radiation can be detected by the detector **170** and/or by another component capable of detecting such activity. The reflected radiation can be distinguished from the original emission and/or other sources of radiation to determine the presence or absence of the band **110**. The reflected radiation can have a distinct signature that is unique to the identification element **190**. Thereby, the watch body **100** can identify the band **110** and perform corresponding actions.

It will be understood that the antenna of the detector **170** can be an antenna that operates for other functions, such as communication with other external devices. It will be further understood that such communication can be performed while simultaneously detecting for any reflected radiation to determine the absence or presence of the band **110**.

In some embodiments, the detector **170** include a capacitive sensor and the identification element **190** can include one or more features that alter capacitance in a nearby region. The housing or other component of the watch body **100** can provide a surface or window for the sensor of the detector **170** to detect, by capacitive influence, the presence or absence of the identification element **190**. The identification element **190** can include a surface, coating, or other feature that, when brought into contact or proximity of the detector **170**, induces a change in the capacitance of the detector **170**. The change in the capacitance can be distinguished from other configurations of the detector **170** to determine the presence or absence of the band **110**. The change in the capacitance can have a distinct signature that is unique to the identification element **190**. Thereby, the watch body **100** can identify the band **110** and perform corresponding actions.

In some embodiments, the detector **170** include an induction coil and the identification element **190** can include one or more features that alter induction in a nearby region. The induction coil can be dedicated to detecting the identification element **190** or operable for other purposes, such as inductive changing of a power source of the watch body **100**. The identification element **190** can include a magnet or other feature that, when brought into proximity of the detector **170**, induces a current to flow through the detector **170**. The induced current can be distinguished from other configurations of the detector **170** to determine the presence or absence of the band **110**. The change in the detector **170** can have a distinct signature that is unique to the identification element **190**. Thereby, the watch body **100** can identify the band **110** and perform corresponding actions.

Referring now to FIG. 6, a method **200** can be performed by a watch body **100** to interact with a band **110**. In an operation **202**, the watch body **100** can initiate a scan for an identification element. The watch body **100** can be placed into a scanning mode based on manual and/or automated initiation. For example, the user can place the watch body **100** into a scanning mode by providing manual inputs to the watch body **100**. For at least a limited period of time thereafter, the watch body **100** can activate its components to scan for the identification element **190** of a band **110**. Alternatively or additionally, the watch body **100** can automatically activate its components after it senses the presence of an identification element **190**, for example as described above. Additionally or alternatively, the electronic device can initiate a scan for an identification element upon detection that the electronic device is worn by a user. For example, when the electronic device detects that it is being worn (e.g., based on proximity to a user as can be sensed by a sensor) after a period of not being worn, the electronic device can initiate a scan to detect the identification element of any band present. By further example, the electronic device can detect the presence of a band based on sensed changes, such as a change in impedance or inductance of a coil when the band is inserted into the electronic device, as discussed further herein. Such changes can be used to initiate a scan. Additionally or alternatively, the electronic device can initiate scans periodically or based on a predetermined schedule.

In an operation **204**, the watch body **100** can detect an identification element **190** of a band **110**. Examples of components and mechanisms for detecting the identification element **190** are described above. One of more of these components and/or mechanisms can be applied to effectively detect the identification element **190**. Once the identification element **190** has been detected, a record thereof can be stored within a memory **152** of the watch body **100**. The identification element **190** can be an indicator of a feature of the band **110**. For example, the identification element **190** can indicate a type, model, color, size, or other characteristic of the band **110**. Where the identification element **190** indicates one characteristic (e.g., model) of the band **110**, other characteristics (e.g., color, size) can be inferred.

The identification can serve as an input to determine an action to be performed by the watch body **100**. In an operation **206**, the watch body **100** can determine an action associated with the identification element **190**. Each of a variety of identification elements **190** corresponding to different bands **110** can be recorded in the memory **152** of the watch body **100**. Each of the recorded identification elements **190** can have associated therewith a corresponding action. The record of identification elements **190** and associated actions can be in the form of a table, array, or other data structure. When a given identification element **190** is detected, it can be compared with the recorded identification elements **190** to find a match and determine the corresponding action. While the foregoing discussion relates to referencing memory **152** onboard the watch body **100**, it will be recognized that the watch body **100** can reference another database apart from the watch body **100**. The association of identification elements **190** and corresponding actions can be preprogrammed, user-selected, or a result of machine-learning based on prior usage with one or more bands **110**.

In an operation **208**, the watch body **100** can perform the action that has been determined to be associated with the identification element **190**. For example, the recorded action corresponding to the detected identification element **190** can include instructions for execution by the processor **150** and/or other components of the watch body **100**. Alternatively or additionally, the action can include causing another device, apart from the watch body **100**, to execute instructions. The action can be performed automatically upon identification of a band **110**. Additionally or alternatively, the watch body **100** can provide a prompt requesting user confirmation of the action, and the action can be performed after user confirmation is received. Additionally or alternatively, a user can manually override or modify the action.

Various examples of actions are discussed below. Actions performed by the watch body **100** in response to detection of an identification element **190** include influencing regular operation of the watch body **100**. For example, the regular operation of the watch body **100** can be maintained with additional or altered features based on the selected band **110**. As such, the user's experience with the watch body **100** during its regular operation is enhanced.

In some embodiments, upon identifying a particular band **110**, the watch body **100** provides a feature of a visual user interface that corresponds to a characteristic of the band **110**. For example, the watch body **100** can display on the display **104** a feature that is substantially the same color as the band **110**. Alternatively or additionally, the feature can be a similar color, a matching color, or a complementary color. The feature can be any visible feature of the display **104**. Examples of features include watch hands, text, numbers, symbols, graphics, charts, markers, or any displayed item. One, some, or all of the features visible on the display **104**

can be altered based on the color of the identified band **110**. By further example, the watch body **100** can display on the display **104** a feature that is associated with the band **110**, regardless of color selection. For example, displayed information, watch faces, menu items, and selectable icons can be selected based on the selection of band **110**.

In some embodiments, upon identifying a particular band **110**, other settings of the watch body **100** can be modified. A band **110** can be associated with an activity that is supported by the watch body **100**. For example, an exercise band can be worn when a user is exercising. Upon identification of the exercise band, actions conducive to an exercise session can be performed by the watch body **100**. For example, the watch body **100** can display particular information, track activity of the user, take a biometric reading, record a location of the user, launch an activity tracking app, and/or modify notifications settings (e.g., to be more prominent). By further example, a formal band can be worn in a more formal setting. Upon identification of the formal band, actions conducive to a formal setting can be performed by the watch body **100**. For example, the watch body **100** can display particular information, modify notifications settings (e.g., to be less prominent), provide reminders to the user, and/or record a location of the user.

Actions performed by the watch body **100** in response to detection of an identification element **190** include actions outside of the regular operation of the watch body **100**. For example, the watch body **100** can perform actions that are only available when a particular band **110** is detected. As such, the user's experience with the watch body **100** is expanded with the selection of bands **110**.

In some embodiments, a band **110** can include an identification element **190** that provides authorization for otherwise unavailable actions. For example, a band **110** can facilitate redemption of items of value. The band **110** can be used with the watch body **100** to redeem items of value, such as credit, gift cards, funds, cash, prizes, digital media, access to content (e.g., online content), goods, and/or services. The identification element **190** can provide information to the watch body **100** for authorizing redemption of an item of value. For example, the identification element **190** can include a code that is verifiable by an external device. As shown in FIG. 7, a system **300** can manage the redemption. The watch body **100** can identify a band **110** and communicate with an external device **310**. Information from the identification element **190** can be transmitted from the watch body **100** to the external device **310**. The external device **310** can verify the information and authorize redemption of an item of value. The external device **310** can further manage the redemption by executing a transfer to an account associated with the watch body **100**. Bands **110** that facilitate redemption of items of value can be provided by vendors, retailers, service providers, or entities that manage the redemption process. The bands **110** can be provided, exchanged, and transferred for sale or as gifts based on the value of the redeemable items. The bands **110** can be provided as promotional items in conjunction with an event. For example, bands **110** can be provided at a festival, convention, conference, concert, or reunion, to provide attendees possessing the bands **110** with access items of value that are associated with the event. Each attendee can access the items of value by using the bands **110** with their watch bodies **100**.

In some embodiments, a band **110** and a watch body **100** can interact and operate in a manner that is not necessarily perceivable by a user. For example, a watch body **100** can track usage of one or more bands **110**. The tracked usage

11

information includes dates, times, durations, locations, activities, biometrics of the user, and/or environmental features in relation to periods before, during, and/or after usage of each band **110**. The tracked usage information can be collected during a background process of the watch body **100**. The tracked usage information can be output to a user or uploaded to an external device for analysis. The tracked usage information can be used for machine learning in relation to how each band **110** is used.

The watch body **100** can perform a variety of other actions upon identification of a band **110**. It will be recognized that the detection of an identification element **190** can be followed by any associated action that can be performed by the watch body **100**. For example, where the watch body **100** has the required capabilities, the watch body **100** launches an app, opens a website, starts a timer, displays a message, provides an alert, communicates with another device, and/or other functions.

Referring now to FIGS. **8** and **9**, a watch can perform different actions when each of a variety of band combinations is detected. For example, multiple band portions can be provided across different sides of the watch body, and each band portion can be independently detected.

For example, as shown in FIG. **8**, a first band portion **110A** and a second band portion **110B** can each be attached to a corresponding one of different (e.g., opposing) sides of the watch body **100** (e.g., at a given channel **114**). The first band portion **110A** can have a characteristic that is the same as or different from a characteristic of the second band portion **110B**. Such characteristics can include a type, model, color, material, size, output, or other characteristic of the corresponding band portion. The characteristic can be detectable or undetectable to a user.

As shown in FIG. **9**, a first detector **170A** on a first side of the watch body **100** can detect a first identification element **190A** of the first band portion **110A**, and a second detector **170B** on a second side of the watch body **100** can detect a second identification element **190B** of the second band portion **110B**. Based on and in response to these detections, the watch body can perform an action. An example of such an action includes providing an output **106** on the display **104** of the watch body **100**. The output **106** can optionally include a visual feature with a characteristic that corresponds to a characteristic of the first band portion **110A** and a characteristic that corresponds to a characteristic of the second band portion **110B**. Further examples include providing other outputs to a user, initiation a function, terminating a function, communicating with another device, and the like.

Referring now to FIG. **10**, multiple detectors can operate in concert to detect identification elements of a band. The multiple detectors can cooperatively provide frequent detection of a band along with accurate and effective detection of the identity of the band.

For example, as shown in FIG. **10**, a band **110** can include a first identification element **190A** and a second identification element **190B**. When the band **110** is attached to the watch body **100** (e.g., by inserting the lug **112** into the channel **114**), the first identification element **190A** can be aligned with a first detector **170A** of the watch body **100**, and the second identification element **190B** can be aligned with a second detector **170B** of the watch body **100**.

It will be recognized that some detection mechanisms can consume more power or have other effects that would preferably be minimized. For example, the second detector **170B** can, when operated, consume more power than the first detector **170A**, when operated. In some embodiments,

12

the first detector **170A** detects the band **110** (e.g., by the first identification element **190A**) in a manner that is different than a manner in which the second detector **170B** detects the second identification element **190B** to accommodate the differences in operation. For example, the first detector **170A** can detect the band **110** on a more frequent basis than the second detector **170B** detects the second identification element **190B**. For example, the first detector **170A** can be “always on” or otherwise be ready to detect the band **110** continuously or periodically. Upon detection of the band **110** by the first detector **170A**, the watch can determine that the band **110** is present and infer that the second identification element **190B** may also be present and available for detection. Based on the first detection, the second detector **170B** can be activated to detect the second identification element **190B** by any mechanisms described herein. By activating the second detector **170B** only after detecting the presence of the band **110** with the first detector **170A**, the operation of the second detector **170B** can be limited to when it is needed. Additionally or alternatively, the second detector **170B** can be deactivated upon detection that the band **110** is not present. Accordingly, power consumption by the second detector **170B** can be reduced without losing an ability to detect the band **110** when present.

Referring now to FIGS. **11-13**, a detector can optically sense the identification element on a lug or another portion of a band. As discussed above, a light source can be provided to facilitate optical sensing by the detector. For example, the detector can include or be accompanied by a light source that illuminates the identification element, and the detector can optically detect the light reflected off of the identification element.

As shown in FIG. **11**, a lug **112** or another portion of a band **110** can include an identification element **190** along a surface thereof. The identification element **190** can include at least one reference row and at least one code row providing patterns with feature that, when compared to the reference row, can indicate an identity or other characteristic of the band **110**.

A reference row can provide a basis for comparison with respect to other rows. A reference row **130** can be provided with a repeating pattern of a shape **132**. As used herein, a row providing a repeating pattern of a given shape is an arrangement of multiple instances of the given shape in a pattern, wherein the instances of the shape occur with at least one visible or otherwise detectable feature in common across the entire pattern. For example, the instances of the repeated shape can all have the same shape, size, dimensions, boundaries, color, periodicity, frequency, orientation, spacing, alignment, and the like.

A code row can provide a feature that, when compared to the reference row, can be used to identify the band. A code row **140** can be provided with a repeating pattern of a shape **142**. The shape **142** repeated along the pattern of the code row **140** can be distinct from the shape **132** that is repeated along the pattern of the reference row **130**. For example, a length of the shape **142** of the code row **140** can be different (e.g., shorter or longer) than a length of the shape **132** of the reference row **130**. The repeating pattern of the shape **142** of the code row **140** can optionally be a positive integer multiple (e.g., harmonic) of a frequency of the repeating pattern of the shape **132** of the reference row **130**. Accordingly, an integer number (e.g., 1, 2, 3, 4, etc.) of shapes **142** of the code row **140** can fit within a single length of the shape **132** of the reference row **130**. This allows a view **172**

captured by the detector to detect and compare the integer number of shapes **142** to a single shape **132** of the reference row **130**.

It will be understood that any number of code rows can be provided. For example, an additional (e.g., second) code row **144** can be provided with a repeating pattern of a shape **146**. The shape **146** repeated along the pattern of the code row **144** can be distinct from the shape **132** of the reference row **130** and/or the shape **142** of the code row **140**. For example, a length of the shape **146** of the code row **144** can be different (e.g., shorter or longer) than a length of the shape **132** of the reference row **130** and/or the shape **142** of the code row **140**. The repeating pattern of the shape **146** of the code row **144** can optionally be a positive integer multiple (e.g., harmonic) of a frequency of the repeating pattern of the shape **132** of the reference row **130**. The positive integer multiple can be different than that of the shape **142** of the code row **140**. Accordingly, an integer number (e.g., 1, 2, 3, 4, etc.) of shapes **146** of the code row **144** can fit within a single length of the shape **132** of the reference row **130**. This allows a view **172** captured by the detector to detect and compare the integer number of shapes **142** to a single shape **132** of the code row **140**.

It will be understood that any number of reference rows can be provided. For example, an additional (e.g., second) reference row **134** can be provided with a repeating pattern of a shape **136**. The reference row **134** can be on an opposite side of the identification element **190** from the other (e.g., first) reference row **130**. The shape **136** repeated along the pattern of the reference row **134** can be the same as the shape **132** of the reference row **130**. For example, the shape **132** and the shape **136** can all have the same shape, size, dimensions, boundaries, color, periodicity, frequency, orientation, spacing, alignment, and the like. Accordingly, the code rows **140** and **144** can be compared to either one or both of the reference rows **130** and **134**.

As shown in FIG. **12**, a detector (not shown) can capture a view **172** of at least a portion of the identification element **190**. Each of the shapes, or portions thereof, within the view **172** can be captured for analysis. For example, the shape(s) of the code row(s) can be compared to the shape(s) of the reference row(s). The shapes can have one or more features that are used as a basis for comparison. For example, such a feature can include a relative phase, amplitude, color, reflectivity, diffraction grating, and/or texture of the second repeating pattern with respect to the first repeating pattern.

The features of the shapes from rows captured in the view **172** can be compared to determine similarities and/or differences there between. In some embodiments, features to be compared can include a relative phase of at least two different repeating patterns. For example, the repeating patterns can have a detectable period. While the pattern can be different, a point within a given period (e.g., peak, trough, etc.) can be compared to a comparable point in a different pattern. For example, the phase of a pattern in a code row can be shifted (e.g., horizontally) relative to the phase of a reference row. The phase of each and/or a relative phase between pairs of patterns can be detected, quantified, and/or compared. The phases of both one or more code rows and/or one or more reference rows can be combined or otherwise analyzed, for example by summation. Further analysis can include, for example, discrete Fourier transform. The output can be used to determine an identify of the band among others and/or distinguish the band from other bands that have different identification elements (e.g., with different features).

It will be understood that a comparison of features can be based on any one or more of a variety of features. For example, such features across different patterns can include a relative phase, amplitude, color, reflectivity, diffraction grating and/or texture of the repeating patterns. Where different types of features are used, the features of the same type from different repeating patterns can be compared, and the different types of features can provide additional dimensions that can be used to distinguish the features of the rows.

The arrangement of the rows and the repeating patterns therein can facilitate the operation of the detector to capture and view with sufficient information to make an identification, even if less than an entirety of the identification element is captured within the view. For example, as shown in FIG. **12**, a length **L** of the view **172** can extend to capture at least one shape **132** of the reference row **130**, a corresponding (e.g., integer) number of shapes **142** of a first code row **140**, and a corresponding (e.g., integer) number of shapes **146** of a second code row **144**, as well as any additional rows.

Because the shapes of each row repeats according to a pattern, the view **172** need not capture an entirety of any row. The length **L** can capture enough of one or more shapes to determine the characteristics of all of the shapes across an entire row. As such, the horizontal (e.g., along the length **L**) alignment of the view **172** (e.g., of the lug relative to the watch body or the identification relative to the detector) need not be limited to only one horizontal region of the identification element. This allows the detection to be made across a wide variety of horizontal alignment arrangements.

Because the shapes of each row repeats according to a pattern, the view **172** need not capture an entire portion of any one shape. For example, where a portion of one shape and a portion of its neighbor in the pattern are captured within the view **172**, the characteristics of either shape can be inferred by the combination of portions within the view **172**.

By further example, as shown in FIG. **13**, a height **H** of the view **172** can extend to capture portions of multiple rows. The height **H** of the view **172** can extend across an entire height of all of the code rows. The height **H** of the view **172** can extend across an entire height of at least one of the reference rows or at least a portion of both reference rows. As shown in FIG. **12**, the shapes of the different reference rows **130** and **134** can be the same, so that the view **172** need not capture an entire height of either one of the reference rows. For example, where a portion of a shape **132** from the first reference row **130** and a portion of a shape **136** from the second reference row **134** are captured within the view **172**, the characteristics of either shape can be inferred by the combination of portions within the view **172**. As such, the vertical (e.g., along the height **H**) alignment of the view **172** (e.g., of the lug relative to the watch body or the identification relative to the detector) need not be limited to only one vertical region of the identification element. This allows the detection to be made across a wide variety of vertical alignment arrangements.

Additionally or alternatively, the identification element **190** can include another symbol, such as a barcode, including a machine-readable representation of information in the form of one or more patterns. The symbol may be formed as patterns of dark (e.g., black) and light (e.g., white) bars, circles, dots or other shapes. Other patterns are contemplated, such as patterns of dots, concentric circles and the like. Other examples of barcodes include Universal Product Codes (UPCs), Code 39 barcodes, Code 128 barcodes, PDF417 barcodes, EZcode barcodes, DataMatrix barcodes,



QR Codebarcodes, or barcodes that utilize any other type of barcode symbology. A 1D sensor or a 2D sensor can be used to capture images of adequate resolution (e.g., pixels) to detect the identification element 190 (e.g., barcode). The depth of focus of the sensor can be arranged so that the barcode is in focus when the band is swiped past the detector 170.

Additionally or alternatively, the detector 170 can be configured to perform barcode scanning. In particular, the detector 170 can capture an image of the identification element 190 and use digital image processing techniques to decode the barcode. During a detection operation, the watch body 100 may prompt a user to line up the detector 170 with the identification element 190 in a particular manner, such as aligning the identification element 190 in the center of an image captured by the detector 170 and displayed on the display 104.

Referring to FIGS. 14 and 15, a band can include an identification element that facilitates wireless communication from within an outer periphery of a lug of the band. The identification element can be housed within a portion of the lug that also helps secure the lug to the housing of the watch body.

As shown in FIG. 14, the lug 112 can include a locking element 116 within an opening of the body 210. The locking element 116 may be positioned at any point along the body 210 and in any orientation. The locking mechanism can slideably move within the opening of the body 210 to engage a portion of the watch body. For example, when the lug 112 is received within the channel of the watch body, the locking element 116 can actuate and/or otherwise engage a portion of the watch body to secure the lug 112 within the channel. The locking element 116 can be released by a user to allow the lug 112 to be removed from the channel. The locking element 116 of the lug 112 can include one or more elements that can controllably protrude from the body 210 to engage the watch body.

As further shown in FIG. 14, the lug 112 can include one or more bumpers 118 that extend or protrude from a body 194 of the lug 112. The bumpers 118 can be positioned at leading edges of the locking element 116 and distributed along the body 194. The bumpers 118 can be positioned on one side or opposing sides of the body 194. The bumpers 118 may include one or more alignment pads that act as a guide for the lug 112 when the lug 112 slides relative to a channel in the housing of the watch body. The bumpers 118 may have a rounded top surface that follows or substantially follows the contour of the body 194 while still protruding from the surface of the body 194. The bumpers 118 may have a planar or substantially planar top surface. Although the bumpers 118 are shown in a rounded oblong or lozenge shape, the bumpers 118 may be curved, proud, flat, angled, have a raised edge and a flat interior or any combination thereof.

The bumpers 118 may be positioned on various parts of the body 194 of the lug 112. For example, a top surface of the body 194 of the lug 112 may include one or more bumpers 118 and the bottom surface of the body 194 of the lug 112 may also include the same or additional bumpers 118. The bumpers 118 may include a casing that is of rubber, plastic, nylon, or other such material. The material may be a material that acts to increase friction between the lug 112 and the channel of the housing of the watch body. The body 194 of the lug 112 may include one or more recesses in which the bumpers 118 may be placed. Additionally or alternatively, the bumpers 118 may be placed directly on top, bottom and/or side surfaces of the body 194 of the lug 112.

Further, the bumpers 118 may be disposed in one or more openings that extend entirely through an axis of the body 194 of the lug 112.

The bumpers 118, or at least a portion of each bumper 118, extends or protrudes from one or more surfaces of the body 194 of the lug 112. In such embodiments, the portion of the bumper 118 that extends beyond the surface of the body 194 of the lug 112 is used to: (1) increase friction between the lug 112 and the channel of the housing of the watch body into which the lug 112 is to be placed; and (2) maintain or substantially maintain spacing between one or more surfaces of the lug 112 and a surface of a channel of the housing of the watch body into which the lug 112 is to be placed. Accordingly, undesired movement, rattling and/or noise caused by any movement of the lug 112 may be reduced when the lug 112 is contained within the channel.

As shown in FIG. 15, a bumper 118 can contain an identification element 190 that facilitates wireless communication with a detector of a watch body. For example, an identification element 190 can include an antenna element 162 and an identification tag 166 (e.g., an NFC tag). The antenna element 162 can be a wound coil, an etched PCB, or another structure for receiving and/or emitting radiation. The identification tag 166 can be operably connected to the antenna element 162. A magnetic (e.g., ferrite) core 164 can be provided (e.g., within the antenna element 162) to facilitate detection of the identification element 190 and/or enhance operation of the antenna element 162.

The components of the identification element 190, including the antenna element 162, the magnetic (e.g., ferrite) core 164, and/or the identification tag 166 can be housed within a casing 168 of the bumper 118. For example, the casing 168 can be molded, potted, or otherwise formed about the other components of the bumper 118. The casing 168 can seal the components of the identification element 190 from an external environment. Additionally, the casing 168 can define an outer periphery of the bumper 118, including the portions thereof that extend beyond the body of the lug and engage the watch body.

While only one wound coil is shown for the antenna element 162 in FIG. 15, it will be understood that a variety of coil arrangements can be provided. For example, the antenna element 162 may include two or more coils (e.g., a pair of coils) that are each wound around a respective core structure (e.g., a pair of corresponding core structures or support structures) that are mounted on, or formed as protrusions from, a surface. Optionally, a single wire can form all of the multiple (e.g., two) coils of the antenna element 162. In one or more implementations, a multi-coil antenna module can communicate with a (e.g., mirrored) multi-coil antenna module in the watch housing to form one or more magnetic flux loops through the multi-coil antennas that can facilitate providing, exchanging, and/or receiving identification, power, and/or other communications between the processing circuitry of the wearable device and the band.

The watch body can be provided with low-power impedance detection circuitry to detect the presence of the identification element 190 near a detector (e.g., NFC radio). One or more additional detectors can be positioned at locations to be aligned with the identification element when the lug is within the channel of the watch body. Detection can be contactless (e.g., non-conductive) so that the components can be protected from Galvanic corrosion that may occur in a contact-based arrangement. The detection can also be autonomous, such that user intervention or explicit operations are not required. Additionally, the detection can be performed without requiring the band to provide its own

power source. It will be recognized that a variety of other configurations are contemplated to provide wireless communication for detection of the identification element 190 of the band 110.

Accordingly, watch bands described herein can facilitate a watch's ability to perform one or more operations based on the detected characteristic and configuration of the watch band. Characteristics of the watch band can change when placed in different configurations, and each of these characteristics can be correlated with each of the various configurations. The characteristics can be measured to detect in which of the various configurations the watch band is in.

Various examples of aspects of the disclosure are described below as clauses for convenience. These are provided as examples, and do not limit the subject technology.

Clause A: a watch comprising: a watch body comprising: a processor; and an optical detector; and a band that is attachable to the watch body for securing the watch to a user and comprising an identification element that is detectable by the optical detector, the identification element comprising: a reference row comprising multiple first shapes in a first repeating pattern; and a code row comprising multiple second shapes in a second repeating pattern.

Clause B: a watch comprising: a watch body comprising: a processor; and an antenna; and a band that is attachable to the watch body for securing the watch to a user and comprising an identification element, wherein: the antenna is operable to emit radiation with a frequency; and the identification element comprises a reflective surface that is configured to reflect at least a portion of the emission.

Clause C: a watch comprising: a watch body comprising: a housing; a processor; and a detector; and a band that is attachable to the watch body for securing the watch to a user and comprising: a lug for being received into a channel of the housing; a locking mechanism for engaging the channel; multiple bumpers protruding from the lug to abut the housing when the lug is received within the channel, each of the multiple bumpers being positioned on opposing sides of the locking mechanism; and an identification element housed within one of the bumpers, wherein the detector is configured to wirelessly communicate with the identification element when the lug is received within the channel.

One or more of the above clauses can include one or more of the features described below. It is noted that any of the following clauses may be combined in any combination with each other, and placed into a respective independent clause, e.g., clause A, B, or C.

Clause 1: the identification element corresponds to a characteristic of the band; and the processor is configured to determine whether to execute an action based on a comparison of a feature of the second repeating pattern with respect to the first repeating pattern.

Clause 2: the feature comprises a relative phase, amplitude, color, reflectivity, or texture of the second repeating pattern with respect to the first repeating pattern.

Clause 3: the second repeating pattern has a frequency that is a positive integer multiple of a frequency of the first repeating pattern.

Clause 4: the reference row is a first reference row; and the identification element further comprises a second reference row on a second side of the identification element, opposite the first side, the second reference row comprising additional first shapes in a third repeating pattern.

Clause 5: the optical detector is configured to capture a view, wherein when less than an entire height of the first

reference row is within the view, at least a portion of a height of the second reference row is within the view.

Clause 6: the code row is a first code row; and the identification element further comprises a second code row comprising multiple third shapes in a third repeating pattern.

Clause 7: the second repeating pattern has a first frequency that is a positive integer multiple of a frequency of the first repeating pattern; and the third repeating pattern has a second frequency, different than the first frequency, that is a positive integer multiple of a frequency of the first repeating pattern.

Clause 8: the identification element corresponds to a characteristic of the band; and the processor is configured to determine whether to execute an action based on the detected identification element.

Clause 9: the watch body further comprises a display; the characteristic of the band is a color of the band; and the action is changing a feature on the display to include the color.

Clause 10: the watch body further comprises: a housing containing the processor and the antenna; a channel for receiving a portion of the band; and a window positioned at the channel and configured to transmit the radiation between the antenna and the identification element when the band is received within the channel.

Clause 11: the identification element is configured to resonate at the frequency of the radiation.

Clause 12: the identification element comprises: a coil; a magnetic core within the coil; and a tag.

Clause 13: the detector is a first detector; the identification element is a first identification element; the watch body further comprises a second detector; and the band further comprises a second identification element housed within another one of the bumpers, wherein the second detector is configured to detect the second identification element when the lug is received within the channel.

As described above, one aspect of the present technology may include the gathering and use of data available from various sources. The present disclosure contemplates that in some instances, this gathered data may include personal information data that uniquely identifies or can be used to contact or locate a specific person. Such personal information data can include demographic data, location-based data, telephone numbers, email addresses, twitter ID's, home addresses, data or records relating to a user's health or level of fitness (e.g., vital signs measurements, medication information, exercise information), date of birth, or any other identifying or personal information.

The present disclosure recognizes that the use of such personal information data, in the present technology, can be used to the benefit of users. For instance, health and fitness data may be used to provide insights into a user's general wellness, or may be used as positive feedback to individuals using technology to pursue wellness goals.

The present disclosure contemplates that the entities responsible for the collection, analysis, disclosure, transfer, storage, or other use of such personal information data will comply with well-established privacy policies and/or privacy practices. In particular, such entities should implement and consistently use privacy policies and practices that are generally recognized as meeting or exceeding industry or governmental requirements for maintaining personal information data private and secure. Such policies should be easily accessible by users, and should be updated as the collection and/or use of data changes. Personal information from users should be collected for legitimate and reasonable uses of the entity and not shared or sold outside of those

legitimate uses. Further, such collection/sharing should occur after receiving the informed consent of the users. Additionally, such entities should consider taking any needed steps for safeguarding and securing access to such personal information data and ensuring that others with access to the personal information data adhere to their privacy policies and procedures. Further, such entities can subject themselves to evaluation by third parties to certify their adherence to widely accepted privacy policies and practices. In addition, policies and practices should be adapted for the particular types of personal information data being collected and/or accessed and adapted to applicable laws and standards, including jurisdiction-specific considerations. For instance, in the US, collection of or access to certain health data may be governed by federal and/or state laws, such as the Health Insurance Portability and Accountability Act (HIPAA); whereas health data in other countries may be subject to other regulations and policies and should be handled accordingly. Hence different privacy practices should be maintained for different personal data types in each country.

Despite the foregoing, the present disclosure also contemplates embodiments in which users selectively block the use of, or access to, personal information data. That is, the present disclosure contemplates that hardware and/or software elements can be provided to prevent or block access to such personal information data. For example, in the case of advertisement delivery services, the present technology can be configured to allow users to select to “opt in” or “opt out” of participation in the collection of personal information data during registration for services or anytime thereafter. In another example, users can select not to provide mood-associated data for targeted content delivery services. In yet another example, users can select to limit the length of time mood-associated data is maintained or entirely prohibit the development of a baseline mood profile. In addition to providing “opt in” and “opt out” options, the present disclosure contemplates providing notifications relating to the access or use of personal information. For instance, a user may be notified upon downloading an app that their personal information data will be accessed and then reminded again just before personal information data is accessed by the app.

Moreover, it is the intent of the present disclosure that personal information data should be managed and handled in a way to minimize risks of unintentional or unauthorized access or use. Risk can be minimized by limiting the collection of data and deleting data once it is no longer needed. In addition, and when applicable, including in certain health related applications, data de-identification can be used to protect a user’s privacy. De-identification may be facilitated, when appropriate, by removing specific identifiers (e.g., date of birth, etc.), controlling the amount or specificity of data stored (e.g., collecting location data a city level rather than at an address level), controlling how data is stored (e.g., aggregating data across users), and/or other methods.

Therefore, although the present disclosure broadly covers use of personal information data to implement one or more various disclosed embodiments, the present disclosure also contemplates that the various embodiments can also be implemented without the need for accessing such personal information data. That is, the various embodiments of the present technology are not rendered inoperable due to the lack of all or a portion of such personal information data. For example, content can be selected and delivered to users by inferring preferences based on non-personal information data or a bare minimum amount of personal information,

such as the content being requested by the device associated with a user, other non-personal information available to the content delivery services, or publicly available information.

To illustrate the interchangeability of hardware and software, items such as the various illustrative blocks, modules, components, methods, operations, instructions, and algorithms have been described generally in terms of their functionality. Whether such functionality is implemented as hardware, software or a combination of hardware and software depends upon the particular application and design constraints imposed on the overall system. Skilled artisans may implement the described functionality in varying ways for each particular application.

A reference to an element in the singular is not intended to mean one and only one unless specifically so stated, but rather one or more. For example, “a” module may refer to one or more modules. An element preceded by “a,” “an,” “the,” or “said” does not, without further constraints, preclude the existence of additional same elements.

Headings and subheadings, if any, are used for convenience only and do not limit the invention. The word exemplary is used to mean serving as an example or illustration. To the extent that the term include, have, or the like is used, such term is intended to be inclusive in a manner similar to the term comprise as comprise is interpreted when employed as a transitional word in a claim. Relational terms such as first and second and the like may be used to distinguish one entity or action from another without necessarily requiring or implying any actual such relationship or order between such entities or actions.

Phrases such as an aspect, the aspect, another aspect, some aspects, one or more aspects, an implementation, the implementation, another implementation, some implementations, one or more implementations, an embodiment, the embodiment, another embodiment, some embodiments, one or more embodiments, a configuration, the configuration, another configuration, some configurations, one or more configurations, the subject technology, the disclosure, the present disclosure, other variations thereof and alike are for convenience and do not imply that a disclosure relating to such phrase(s) is essential to the subject technology or that such disclosure applies to all configurations of the subject technology. A disclosure relating to such phrase(s) may apply to all configurations, or one or more configurations. A disclosure relating to such phrase(s) may provide one or more examples. A phrase such as an aspect or some aspects may refer to one or more aspects and vice versa, and this applies similarly to other foregoing phrases.

A phrase “at least one of” preceding a series of items, with the terms “and” or “or” to separate any of the items, modifies the list as a whole, rather than each member of the list. The phrase “at least one of” does not require selection of at least one item; rather, the phrase allows a meaning that includes at least one of any one of the items, and/or at least one of any combination of the items, and/or at least one of each of the items. By way of example, each of the phrases “at least one of A, B, and C” or “at least one of A, B, or C” refers to only A, only B, or only C; any combination of A, B, and C; and/or at least one of each of A, B, and C.

It is understood that the specific order or hierarchy of steps, operations, or processes disclosed is an illustration of exemplary approaches. Unless explicitly stated otherwise, it is understood that the specific order or hierarchy of steps, operations, or processes may be performed in different order. Some of the steps, operations, or processes may be performed simultaneously. The accompanying method claims, if any, present elements of the various steps, operations or

21

processes in a sample order, and are not meant to be limited to the specific order or hierarchy presented. These may be performed in serial, linearly, in parallel or in different order. It should be understood that the described instructions, operations, and systems can generally be integrated together in a single software/hardware product or packaged into multiple software/hardware products.

In one aspect, a term coupled or the like may refer to being directly coupled. In another aspect, a term coupled or the like may refer to being indirectly coupled.

Terms such as top, bottom, front, rear, side, horizontal, vertical, and the like refer to an arbitrary frame of reference, rather than to the ordinary gravitational frame of reference. Thus, such a term may extend upwardly, downwardly, diagonally, or horizontally in a gravitational frame of reference.

The disclosure is provided to enable any person skilled in the art to practice the various aspects described herein. In some instances, well-known structures and components are shown in block diagram form in order to avoid obscuring the concepts of the subject technology. The disclosure provides various examples of the subject technology, and the subject technology is not limited to these examples. Various modifications to these aspects will be readily apparent to those skilled in the art, and the principles described herein may be applied to other aspects.

All structural and functional equivalents to the elements of the various aspects described throughout the disclosure that are known or later come to be known to those of ordinary skill in the art are expressly incorporated herein by reference and are intended to be encompassed by the claims. Moreover, nothing disclosed herein is intended to be dedicated to the public regardless of whether such disclosure is explicitly recited in the claims. No claim element is to be construed under the provisions of 35 U.S.C. § 112, sixth paragraph, unless the element is expressly recited using the phrase “means for” or, in the case of a method claim, the element is recited using the phrase “step for”.

The title, background, brief description of the drawings, abstract, and drawings are hereby incorporated into the disclosure and are provided as illustrative examples of the disclosure, not as restrictive descriptions. It is submitted with the understanding that they will not be used to limit the scope or meaning of the claims. In addition, in the detailed description, it can be seen that the description provides illustrative examples and the various features are grouped together in various implementations for the purpose of streamlining the disclosure. The method of disclosure is not to be interpreted as reflecting an intention that the claimed subject matter requires more features than are expressly recited in each claim. Rather, as the claims reflect, inventive subject matter lies in less than all features of a single disclosed configuration or operation. The claims are hereby incorporated into the detailed description, with each claim standing on its own as a separately claimed subject matter.

The claims are not intended to be limited to the aspects described herein, but are to be accorded the full scope consistent with the language claims and to encompass all legal equivalents. Notwithstanding, none of the claims are intended to embrace subject matter that fails to satisfy the requirements of the applicable patent law, nor should they be interpreted in such a way.

What is claimed is:

1. A watch comprising:

a watch body comprising:  
a processor; and  
an optical detector; and

22

a band that is attachable to the watch body for securing the watch to a user and comprising an identification element that is detectable by the optical detector, the identification element comprising:

a reference row comprising multiple first shapes in a first repeating pattern; and

a code row comprising multiple second shapes in a second repeating pattern.

2. The watch of claim 1, wherein:

the identification element corresponds to a characteristic of the band; and

the processor is configured to determine whether to execute an action based on a comparison of a feature of the second repeating pattern with respect to the first repeating pattern.

3. The watch of claim 2, wherein the feature comprises a relative phase, amplitude, color, reflectivity, or texture of the second repeating pattern with respect to the first repeating pattern.

4. The watch of claim 1, wherein the second repeating pattern has a frequency that is a positive integer multiple of a frequency of the first repeating pattern.

5. The watch of claim 1, wherein:

the reference row is a first reference row on a first side of the identification element; and

the identification element further comprises a second reference row on a second side of the identification element, opposite the first side, the second reference row comprising additional first shapes in a third repeating pattern.

6. The watch of claim 5, wherein the optical detector is configured to capture a view, wherein when less than an entire height of the first reference row is within the view, at least a portion of a height of the second reference row is within the view.

7. The watch of claim 1, wherein:

the code row is a first code row; and

the identification element further comprises a second code row comprising multiple third shapes in a third repeating pattern.

8. The watch of claim 7, wherein:

the second repeating pattern has a first frequency that is a positive integer multiple of a frequency of the first repeating pattern; and

the third repeating pattern has a second frequency, different than the first frequency, that is a positive integer multiple of a frequency of the first repeating pattern.

9. The watch of claim 1, wherein:

the identification element corresponds to a characteristic of the band; and

the processor is configured to determine whether to execute an action based on the detected identification element.

10. The watch of claim 9, wherein:

the watch body further comprises a display;

the characteristic of the band is a color of the band; and  
the action is changing a feature on the display to include the color.

11. A watch comprising:

a watch body comprising:

a processor; and  
an antenna; and

a band that is attachable to the watch body for securing the watch to a user and comprising an identification element,

23

wherein:

the antenna is operable to emit radiation with a frequency; and  
the identification element comprises a reflective surface that is configured to reflect at least a portion of the radiation.

12. The watch of claim 11, wherein the watch body further comprises:

a housing containing the processor and the antenna;  
a channel for receiving a portion of the band; and  
a window positioned at the channel and configured to transmit the radiation between the antenna and the identification element when the band is received within the channel.

13. The watch of claim 11, wherein the identification element is configured to resonate at the frequency of the radiation.

14. The watch of claim 11, wherein:  
the identification element corresponds to a characteristic of the band; and

the processor is configured to determine whether to execute an action based on the identification element.

15. The watch of claim 14, wherein:  
the watch body further comprises a display;  
the characteristic of the band is a color of the band; and  
the action is changing a feature on the display to include the color.

16. A watch comprising:

a watch body comprising:

a housing;  
a processor; and  
a detector; and

a band that is attachable to the watch body for securing the watch to a user and comprising:

24

a lug for being received into a channel of the housing;  
a locking mechanism for engaging the channel;  
multiple bumpers protruding from the lug to abut the housing when the lug is received within the channel, each of the multiple bumpers being positioned on opposing sides of the locking mechanism; and  
an identification element housed within one of the bumpers, wherein the detector is configured to wirelessly communicate with the identification element when the lug is received within the channel.

17. The watch of claim 16, wherein the identification element comprises:

a coil;  
a magnetic core within the coil; and  
a tag.

18. The watch of claim 16, wherein:

the detector is a first detector;  
the identification element is a first identification element;  
the watch body further comprises a second detector; and  
the band further comprises a second identification element housed within another one of the bumpers, wherein the second detector is configured to detect the second identification element when the lug is received within the channel.

19. The watch of claim 16, wherein:

the identification element corresponds to a characteristic of the band; and  
the processor is configured to determine whether to execute an action based on the identification element.

20. The watch of claim 19, wherein:

the watch body further comprises a display;  
the characteristic of the band is a color of the band; and  
the action is changing a feature on the display to include the color.

\* \* \* \* \*